

STATE OF MAINE

MAINE FUEL BOARD

LAWS AND RULES



DEPARTMENT OF PROFESSIONAL AND FINANCIAL REGULATION
OFFICE OF PROFESSIONAL AND OCCUPATIONAL REGULATION

MAINE FUEL BOARD
35 STATE HOUSE STATION
AUGUSTA, MAINE 04333
TELEPHONE: 207-624-8627

<https://www.maine.gov/pfr/professionallicensing/professions/fuel/index.html>

Updated: March 21, 2019

Title 32: PROFESSIONS AND OCCUPATIONS

Chapter 139: MAINE FUEL BOARD

Table of Contents

| | |
|---|-----------|
| Subchapter 1. GENERAL PROVISIONS..... | 3 |
| Section 18101. DEFINITIONS..... | 3 |
| Section 18102. LICENSE REQUIRED..... | 4 |
| Section 18103. VIOLATIONS; PENALTIES..... | 4 |
| Section 18104. EXCEPTIONS..... | 5 |
| Section 18105. MUNICIPAL LICENSES NOT REQUIRED; MUNICIPAL PERMITS..... | 6 |
| Section 18106. MAJOR EQUIPMENT SALES INFORMATION..... | 6 |
| Section 18107. INSTALLATIONS TO CONFORM TO STANDARDS..... | 6 |
| Section 18108. DISCLOSURES; PENALTIES..... | 7 |
| Section 18109. INSPECTION OF ABOVEGROUND AND UNDERGROUND PROPANE AND NATURAL GAS STORAGE FACILITIES AND ROOFTOP INSTALLATIONS OF ASME CONTAINERS..... | 8 |
| Section 18110. STATE FUEL INSPECTOR..... | 8 |
| Section 18111. FAILURE TO COMPLY WITH ORDER OF A STATE FUEL INSPECTOR..... | 9 |
| Subchapter 2. MAINE FUEL BOARD..... | 9 |
| Section 18121. BOARD ESTABLISHED; MEMBERSHIP; TERMS..... | 9 |
| Section 18122. MEETINGS; CHAIR..... | 10 |
| Section 18123. POWERS AND DUTIES..... | 10 |
| Subchapter 3. LICENSING..... | 11 |
| Section 18131. GENERAL QUALIFICATIONS..... | 11 |
| Section 18132. MASTER OIL BURNER TECHNICIAN OR SOLID FUEL TECHNICIAN..... | 11 |
| Section 18133. JOURNEYMAN OIL BURNER TECHNICIAN OR SOLID FUEL TECHNICIAN..... | 12 |
| Section 18134. APPRENTICE OIL AND SOLID FUEL BURNING TECHNICIAN..... | 13 |
| Section 18134-A. EXCEPTION; BLEEDING OF A RESIDENTIAL HOME HEATING OIL BURNER..... | 13 |
| Section 18135. PROPANE AND NATURAL GAS TECHNICIAN..... | 13 |
| Section 18136. PROPANE AND NATURAL GAS HELPER..... | 14 |
| Section 18137. TEMPORARY LICENSE; PLANT OPERATOR OR DELIVERY TECHNICIAN..... | 15 |
| Section 18138. OIL ENERGY AUDITOR..... | 15 |
| Section 18139. PROPANE AND NATURAL GAS ENERGY AUDITOR..... | 16 |
| Section 18140. TANK INSTALLER..... | 16 |
| Section 18141. WOOD PELLET TECHNICIAN..... | 17 |

Section 18142. LICENSURE; INSTALLATION AND MAINTENANCE STANDARDS;
DISPENSING STATIONS..... 17

Section 18143. FEES..... 17

Section 18144. RENEWALS..... 18

Maine Revised Statutes
Title 32: PROFESSIONS AND OCCUPATIONS
Chapter 139: MAINE FUEL BOARD

Subchapter 1: GENERAL PROVISIONS

§18101. DEFINITIONS

As used in this chapter, unless the context otherwise indicates, the following terms have the following meanings. [2009, c. 344, Pt. C, §3 (NEW); 2009, c. 344, Pt. E, §2 (AFF).]

1. Accessory equipment. "Accessory equipment" means equipment, materials and controls that are not integral parts of the oil, solid fuel, propane or natural gas burning unit but that are connected to the oil, solid fuel, propane or natural gas burning unit and have the potential to affect the safety of the equipment.

[2009, c. 344, Pt. C, §3 (NEW); 2009, c. 344, Pt. E, §2 (AFF) .]

2. ASME container. "ASME container" means a container constructed in accordance with a code developed by the American Society of Mechanical Engineers or its successor organization.

[2009, c. 344, Pt. C, §3 (NEW); 2009, c. 344, Pt. E, §2 (AFF) .]

3. Board. "Board" means the Maine Fuel Board established in Title 5, section 12004-A, subsection 49.

[2009, c. 344, Pt. C, §3 (NEW); 2009, c. 344, Pt. E, §2 (AFF) .]

4. Chimney. "Chimney" means a factory-built, masonry or metal chimney constructed to allow one or more vertical or nearly vertical passageways for conveying flue gases from a building to the outside atmosphere.

[2009, c. 344, Pt. C, §3 (NEW); 2009, c. 344, Pt. E, §2 (AFF) .]

5. Dispensing station. "Dispensing station" means a licensed facility consisting of fixed equipment where propane or natural gas is stored and dispensed into portable containers.

[2009, c. 344, Pt. C, §3 (NEW); 2009, c. 344, Pt. E, §2 (AFF) .]

6. Equipment installations. "Equipment installations" means the installation, alteration or repair of oil, solid fuel, propane or natural gas burning equipment and chimneys, or pellet-fired central heating appliances, including accessory equipment as relating only to the safety of the installation. Associated electrical equipment must be wired in compliance with the rules of the Electricians' Examining Board established in Title 5, section 12004-A, subsection 13.

[2015, c. 169, §1 (AMD) .]

7. Natural gas. "Natural gas" means hydrocarbon fuel in a gaseous state with a composition of predominantly CH₄.

[2015, c. 169, §1 (AMD) .]

8. NFPA. "NFPA" means the National Fire Protection Association.

[2009, c. 344, Pt. C, §3 (NEW); 2009, c. 344, Pt. E, §2 (AFF) .]

9. Propane. "Propane" means a hydrocarbon fuel with a chemical composition of predominantly C₃H₈, whether recovered from natural gas or from crude oil.

[2009, c. 344, Pt. C, §3 (NEW); 2009, c. 344, Pt. E, §2 (AFF) .]

10. Self-service dispensing station. "Self-service dispensing station" means a licensed facility where propane or natural gas is dispensed into permanently mounted fuel containers on vehicles.

[2015, c. 169, §1 (AMD) .]

11. Solid fuel. "Solid fuel" means coal, wood, pellets and other similar organic materials or any combination of them.

[2013, c. 217, Pt. I, §1 (AMD) .]

12. State fuel inspector. "State fuel inspector" means a person employed by the Department of Professional and Financial Regulation, Office of Professional and Occupational Regulation to enforce the provisions of this chapter.

[2009, c. 344, Pt. C, §3 (NEW); 2009, c. 344, Pt. E, §2 (AFF); 2011, c. 286, Pt. B, §5 (REV) .]

13. Wood pellets. "Wood pellets" means a wood fuel product manufactured from compressed sawdust or other wood by-product that is pressed or extruded into pieces of uniform size and shape that are designed to be fed in bulk to a combustion chamber. "Wood pellets" does not include ground wood chips.

[2009, c. 344, Pt. C, §3 (NEW); 2009, c. 344, Pt. E, §2 (AFF) .]

SECTION HISTORY

2009, c. 344, Pt. C, §3 (NEW). 2009, c. 344, Pt. E, §2 (AFF). 2011, c. 286, Pt. B, §5 (REV). 2013, c. 217, Pt. I, §1 (AMD). 2015, c. 169, §1 (AMD).

§18102. LICENSE REQUIRED

A person who installs or services solid fuel burning equipment, including pellet-fired central heating appliances, or oil, propane or natural gas burning equipment and a facility where propane or natural gas is dispensed must be licensed under this chapter, except as provided under section 18104. [2015, c. 169, §2 (AMD) .]

SECTION HISTORY

2009, c. 344, Pt. C, §3 (NEW). 2009, c. 344, Pt. E, §2 (AFF). 2015, c. 169, §2 (AMD).

§18103. VIOLATIONS; PENALTIES

1. Unlicensed practice. A person, firm or corporation who makes an oil, solid fuel, propane or natural gas installation without being licensed as provided by subchapter 3 or who employs an unlicensed person to make installations is subject to the provisions of Title 10, section 8003-C.

[2009, c. 344, Pt. C, §3 (NEW); 2009, c. 344, Pt. E, §2 (AFF) .]

2. Strict liability. Except as otherwise specifically provided, violation of this section is a strict liability crime as defined in Title 17-A, section 34, subsection 4-A.

[2009, c. 344, Pt. C, §3 (NEW); 2009, c. 344, Pt. E, §2 (AFF) .]

SECTION HISTORY

2009, c. 344, Pt. C, §3 (NEW). 2009, c. 344, Pt. E, §2 (AFF).

§18104. EXCEPTIONS

The licensing provisions of this chapter do not apply to: [2009, c. 344, Pt. C, §3 (NEW); 2009, c. 344, Pt. E, §2 (AFF).]

1. Electricians. An electrician duly licensed under chapter 17 insofar as the installation of electrical equipment or the performance of any electrical work involved in the installation of oil or solid fuel or propane or natural gas burners is concerned;

[2009, c. 344, Pt. C, §3 (NEW); 2009, c. 344, Pt. E, §2 (AFF) .]

2. Engineers and operators. A person holding an engineer's license issued under section 15109, or working under the general supervision of one so licensed while performing oil or solid fuel burner repair and maintenance on propane or natural gas burning equipment as is necessary in the steam or heating plant where that person is employed, if that work is performed in compliance with section 18107, or a person employed by companies under the jurisdiction of the Public Utilities Commission;

[2009, c. 344, Pt. C, §3 (NEW); 2009, c. 344, Pt. E, §2 (AFF) .]

3. Equipment. Solid fuel burning fireplace stoves, room heaters and stoves designed exclusively for heating and cooking and not attached to a central heating system and heating or cooling equipment operated by means of solar energy;

[2009, c. 344, Pt. C, §3 (NEW); 2009, c. 344, Pt. E, §2 (AFF) .]

4. Highway transport drivers. A highway transport driver who drives a tractor-trailer commercial motor vehicle that has a cargo tank with a water capacity of 9,000 gallons or more and delivers propane to a bulk plant, as defined in NFPA standards, Number 58, or industrial customers;

[2009, c. 344, Pt. C, §3 (NEW); 2009, c. 344, Pt. E, §2 (AFF) .]

5. Individual user of a self-service propane or natural gas dispensing station. An individual user of a self-service propane or natural gas dispensing station;

[2009, c. 344, Pt. C, §3 (NEW); 2009, c. 344, Pt. E, §2 (AFF) .]

6. Mechanics. The installation of air-handling equipment, sheet metal and other specialized equipment and services associated with oil or solid fuel or propane or natural gas burning equipment made by qualified mechanics of those trades who do not hold a master oil and solid fuel burning technician's license under section 18132, journeyman oil and solid fuel burning technician's license under section 18133, apprentice oil and solid fuel burning technician's license under section 18134 or propane and natural gas technician's license under section 18135. Such an installation must conform to the standards and rules of the board and must be made under the supervision of a master oil and solid fuel burning technician or propane and natural gas technician having responsibility for the installation;

[2009, c. 344, Pt. C, §3 (NEW); 2009, c. 344, Pt. E, §2 (AFF) .]

7. Personal abode. A person making an oil, solid fuel, propane or natural gas burning installation in a single family residence occupied or to be occupied by that person as that person's bona fide personal abode, provided that the installation conforms with standards and rules of the board;

[2009, c. 344, Pt. C, §3 (NEW); 2009, c. 344, Pt. E, §2 (AFF) .]

8. Persons working on internal combustion engines and associated gas trains. A person who works on internal combustion engines and associated gas trains;

[2009, c. 344, Pt. C, §3 (NEW); 2009, c. 344, Pt. E, §2 (AFF) .]

9. Plumbers. A plumber duly licensed under chapter 49 insofar as the work covered by that chapter is involved; and

[2009, c. 344, Pt. C, §3 (NEW); 2009, c. 344, Pt. E, §2 (AFF) .]

10. Regular employees of industrial facilities. Regular employees of industrial plants installing and servicing oil, solid fuel, propane or natural gas burning equipment of greater than 10,000,000 BTUs per hour input.

[2009, c. 344, Pt. C, §3 (NEW); 2009, c. 344, Pt. E, §2 (AFF) .]

SECTION HISTORY

2009, c. 344, Pt. C, §3 (NEW). 2009, c. 344, Pt. E, §2 (AFF).

§18105. MUNICIPAL LICENSES NOT REQUIRED; MUNICIPAL PERMITS

A municipality, notwithstanding any provision of a municipal charter, may not require an oil and solid fuel burning technician or a propane and natural gas technician to be municipally licensed. A municipality may not issue a permit for an oil, solid fuel, propane or natural gas burning installation unless satisfied that the person applying for the permit complies with the requirements of this chapter. [2009, c. 344, Pt. C, §3 (NEW); 2009, c. 344, Pt. E, §2 (AFF).]

SECTION HISTORY

2009, c. 344, Pt. C, §3 (NEW). 2009, c. 344, Pt. E, §2 (AFF).

§18106. MAJOR EQUIPMENT SALES INFORMATION

Upon request by the board or its authorized agent, a wholesaler or retailer of major oil, solid fuel, propane and natural gas heating equipment shall provide sales information to the board regarding that equipment. Sales information regarding the equipment may include the identity of the purchaser, the date of purchase, the make, model and serial number, if applicable, and any other information requested. [2009, c. 344, Pt. C, §3 (NEW); 2009, c. 344, Pt. E, §2 (AFF).]

SECTION HISTORY

2009, c. 344, Pt. C, §3 (NEW). 2009, c. 344, Pt. E, §2 (AFF).

§18107. INSTALLATIONS TO CONFORM TO STANDARDS

1. Board standards and rules. Installation of oil, solid fuel, propane and natural gas burning equipment and chimneys may not be made in this State unless the installation complies with all the standards and rules adopted by the board. These standards and rules may not prohibit:

A. The continued use of an existing connection of a solid fuel burning appliance to a chimney flue to which another appliance burning oil or solid fuel is connected for any chimney existing and in use prior to February 2, 1998 as long as:

- (1) Sufficient draft is available for each appliance;
- (2) The chimney is lined and structurally intact; and
- (3) A carbon monoxide detector is installed in the building near a bedroom; or [2011, c. 225, §2 (NEW) .]

B. The connection of a solid fuel burning appliance to a chimney flue to which another appliance burning oil or solid fuel is connected for any chimney existing and in use on or after February 2, 1998 as long as:

- (1) Sufficient draft is available for each appliance;
- (2) The chimney is lined and structurally intact;
- (3) A carbon monoxide detector is installed in the building near a bedroom;
- (4) The solid fuel burning appliance has been listed by Underwriters Laboratories or by an independent, nationally recognized testing laboratory or other testing laboratory approved by the board; and
- (5) The solid fuel burning appliance is installed in accordance with the manufacturer's installation specifications. [2011, c. 225, §2 (NEW) .]

[2011, c. 225, §2 (NEW) .]

2. Technician responsibility for ascertaining total conformance to the standards and rules.

Whenever oil, solid fuel, propane and natural gas burning equipment, accessory equipment or its installation are separately contracted, the master oil and solid fuel burning technician or the propane and natural gas technician in charge of the installation is responsible for ascertaining total conformance to the standards and rules adopted by the board.

[2011, c. 225, §2 (NEW) .]

3. Proof of license. Whenever a state fuel inspector authorized under section 18110 finds a person installing or assisting in an oil, propane, natural gas or solid fuel burning appliance installation, that person shall, on request of the state fuel inspector, provide evidence of being properly licensed when required by this chapter and, if unable to provide the evidence, shall furnish the state fuel inspector with that person's full name and address and, if applicable, the full name and address of the master oil and solid fuel burning technician or the propane and natural gas technician in charge.

[2011, c. 225, §2 (NEW) .]

SECTION HISTORY

2009, c. 344, Pt. C, §3 (NEW). 2009, c. 344, Pt. E, §2 (AFF). 2009, c. 652, Pt. A, §46 (AMD). 2011, c. 225, §2 (RPR).

§18108. DISCLOSURES; PENALTIES

A person, firm or company that installs a chimney or fireplace for compensation must issue, prior to the installation taking place, a disclosure statement to a consumer that the chimney or fireplace complies with NFPA standards, Number 211. The disclosure statement must be in a format approved by the board and contain the information the board considers necessary. Any chimney or fireplace installer who fails to provide

the required disclosure statement to a consumer prior to the installation of a chimney or fireplace commits a civil violation for which a fine of not less than \$500 may be adjudged. [2009, c. 344, Pt. C, §3 (NEW); 2009, c. 344, Pt. E, §2 (AFF).]

SECTION HISTORY

2009, c. 344, Pt. C, §3 (NEW). 2009, c. 344, Pt. E, §2 (AFF).

§18109. INSPECTION OF ABOVEGROUND AND UNDERGROUND PROPANE AND NATURAL GAS STORAGE FACILITIES AND ROOFTOP INSTALLATIONS OF ASME CONTAINERS

The board shall inspect and issue permits to aboveground and underground propane and natural gas storage facilities and rooftop installations of ASME containers to a person who applies and submits a fee under section 18143. [2009, c. 344, Pt. C, §3 (NEW); 2009, c. 344, Pt. E, §2 (AFF).]

SECTION HISTORY

2009, c. 344, Pt. C, §3 (NEW). 2009, c. 344, Pt. E, §2 (AFF).

§18110. STATE FUEL INSPECTOR

1. Inspection. A state fuel inspector, upon written complaint or whenever a state fuel inspector considers it necessary, for purposes of examination may enter into and upon and inspect all buildings, dispensing stations and premises within that state fuel inspector's jurisdiction at all reasonable hours. An inspector may enter a building, dispensing station or other premises within that state fuel inspector's jurisdiction only with the permission of the person having control of the building, dispensing station or other premises or, after hearing, upon order of the court. Whenever a state fuel inspector finds any installation of oil, solid fuel, propane or natural gas equipment or a chimney in a building or structure that does not comply with the requirements of this chapter, that inspector shall order that the installation be removed or remedied, and that order must be complied with immediately by the owner or occupant of the building, dispensing station or other premises or by the installer of the equipment in violation. If a state fuel inspector finds an installation that falls under the inspector's jurisdiction in a building, dispensing station or structure that creates a danger to other property or to the public, the inspector may serve a written order upon the owner and the occupant, if any, to vacate within a reasonable period of time to be stated in the order.

[2009, c. 344, Pt. C, §3 (NEW); 2009, c. 344, Pt. E, §2 (AFF) .]

2. Order to correct deficiency; appeal. A person ordered by a state fuel inspector to correct a deficiency or to vacate a building or structure may appeal the order by filing a written notice of appeal with the board within 30 days after receipt of the order. The board shall schedule an appeal hearing as soon as practicable upon receipt of a timely notice of appeal. The appeal hearing must be conducted de novo and is governed by the provisions of the Maine Administrative Procedure Act applicable to adjudicatory hearings. The state fuel inspector who issued the order on appeal has the burden of proof at the appeal hearing. If the board upholds the order, it shall prescribe the time required for compliance. The person receiving the order under subsection 1 may appeal the board's decision by filing a petition for review in Superior Court in accordance with Title 5, chapter 375, subchapter 7 within 30 days after receipt of the board's written decision.

[2009, c. 344, Pt. C, §3 (NEW); 2009, c. 344, Pt. E, §2 (AFF) .]

3. Final orders. The decision of the Superior Court on an appeal is final. An order by a state fuel inspector and an order by the board are final and subject to no further appeal upon failure to file a timely, written appeal as provided in subsection 2.

[2009, c. 344, Pt. C, §3 (NEW); 2009, c. 344, Pt. E, §2 (AFF) .]

4. Injunction to enforce order. Upon the failure of any person to carry out a final order as provided in subsection 3, the board may petition the Superior Court for the county in which the building or dispensing station or structure is located for an injunction to enforce that order. If the court determines, on hearing such a petition, that a lawful final order was issued, it shall order compliance.

[2009, c. 344, Pt. C, §3 (NEW); 2009, c. 344, Pt. E, §2 (AFF) .]

5. Authority of state fuel inspectors. A state fuel inspector has authority throughout the several counties of the State, similar to that of a sheriff's, relating to enforcement of this chapter and rules adopted under this chapter. These powers are limited to the issuing of citations, the serving of summonses, the conducting of investigations, the ordering of corrections of violations and the issuance of orders to vacate a building or structure in accordance with this chapter. A state fuel inspector may review the oil, solid fuel, propane or natural gas equipment or chimney installation records of any person licensed under this chapter or any person performing installations authorized under this chapter.

[2009, c. 344, Pt. C, §3 (NEW); 2009, c. 344, Pt. E, §2 (AFF) .]

SECTION HISTORY

2009, c. 344, Pt. C, §3 (NEW). 2009, c. 344, Pt. E, §2 (AFF).

§18111. FAILURE TO COMPLY WITH ORDER OF A STATE FUEL INSPECTOR

If the owner, occupant of any building or an installer neglects or refuses, without justification, for more than 10 days to comply with any order of a state fuel inspector, that person commits a civil violation for which a fine of not less than \$100 for each day's neglect may be adjudged. [2009, c. 344, Pt. C, §3 (NEW); 2009, c. 344, Pt. E, §2 (AFF).]

SECTION HISTORY

2009, c. 344, Pt. C, §3 (NEW). 2009, c. 344, Pt. E, §2 (AFF).

Subchapter 2: MAINE FUEL BOARD

§18121. BOARD ESTABLISHED; MEMBERSHIP; TERMS

The Maine Fuel Board, established by Title 5, section 12004-A, subsection 49, consists of 9 members. The Governor shall appoint the members described in subsections 1 to 4. All members must be residents of this State. The 7 members that are required to hold a license must have been licensed for at least the 7 years immediately prior to appointment to the board. The board consists of: [2009, c. 344, Pt. C, §3 (NEW); 2009, c. 344, Pt. E, §2 (AFF).]

1. Oil and solid fuel burning technicians. Three members who each hold a valid license as a master oil and solid fuel burning technician, including one licensed by a solid fuel authority;

[2009, c. 344, Pt. C, §3 (NEW); 2009, c. 344, Pt. E, §2 (AFF) .]

2. Propane and natural gas technicians. Three members who each hold a valid license as a propane and natural gas technician, including one who works in the natural gas industry;

[2009, c. 344, Pt. C, §3 (NEW); 2009, c. 344, Pt. E, §2 (AFF) .]

3. Dual licensed member. One member who is licensed both as a master oil and solid fuel burning technician and a propane and natural gas technician;

[2009, c. 344, Pt. C, §3 (NEW); 2009, c. 344, Pt. E, §2 (AFF) .]

4. Public member. One public member as defined in Title 5, section 12004-A; and

[2009, c. 344, Pt. C, §3 (NEW); 2009, c. 344, Pt. E, §2 (AFF) .]

5. Member appointed by Commissioner of Public Safety. One member appointed by the Commissioner of Public Safety as that commissioner's representative.

[2009, c. 344, Pt. C, §3 (NEW); 2009, c. 344, Pt. E, §2 (AFF) .]

Appointments are for 3-year terms. Appointments of members must comply with Title 10, section 8009. A board member may be removed by the Governor for cause. [2009, c. 344, Pt. C, §3 (NEW); 2009, c. 344, Pt. E, §2 (AFF).]

SECTION HISTORY

2009, c. 344, Pt. C, §3 (NEW). 2009, c. 344, Pt. E, §2 (AFF).

§18122. MEETINGS; CHAIR

The board shall meet at least once a year to conduct its business and to elect a chair. Additional meetings are held as necessary to conduct the business of the board and may be convened at the call of the chair or a majority of the board members. [2013, c. 246, Pt. B, §29 (AMD).]

SECTION HISTORY

2009, c. 344, Pt. C, §3 (NEW). 2009, c. 344, Pt. E, §2 (AFF). 2013, c. 246, Pt. B, §29 (AMD).

§18123. POWERS AND DUTIES

The board has the following powers and duties. [2009, c. 344, Pt. C, §3 (NEW); 2009, c. 344, Pt. E, §2 (AFF).]

1. Board to enforce this chapter. The board shall enforce the provisions of this chapter.

[2009, c. 344, Pt. C, §3 (NEW); 2009, c. 344, Pt. E, §2 (AFF) .]

2. Rules. The board may adopt rules commensurate with the authority vested in it by this chapter, including, but not limited to, rules adopting technical standards for the proper installation and servicing of oil, solid fuel, propane and natural gas burning equipment. Rules adopted pursuant to this subsection may not prohibit:

A. The continued use of an existing connection of a solid fuel burning appliance to a chimney flue to which another appliance burning oil or solid fuel is connected for any chimney existing and in use prior to February 2, 1998 as long as:

- (1) Sufficient draft is available for each appliance;
- (2) The chimney is lined and structurally intact; and
- (3) A carbon monoxide detector is installed in the building near a bedroom; or [2011, c. 225, §3 (NEW).]

B. The connection of a solid fuel burning appliance to a chimney flue to which another appliance burning oil or solid fuel is connected for any chimney existing and in use on or after February 2, 1998 as long as:

- (1) Sufficient draft is available for each appliance;
- (2) The chimney is lined and structurally intact;
- (3) A carbon monoxide detector is installed in the building near a bedroom;

(4) The solid fuel burning appliance has been listed by Underwriters Laboratories or by an independent, nationally recognized testing laboratory or other testing laboratory approved by the board; and

(5) The solid fuel burning appliance is installed in accordance with the manufacturer's installation specifications. [2011, c. 225, §3 (NEW).]

The board may adopt by rule national or other technical standards, in whole or in part, that it considers necessary to carry out the provisions of this chapter. Rules adopted pursuant to this subsection are routine technical rules as defined by Title 5, chapter 375, subchapter 2-A.

[2011, c. 225, §3 (RPR) .]

3. Emerging technologies.

[2015, c. 169, §3 (RP) .]

SECTION HISTORY

2009, c. 344, Pt. C, §3 (NEW). 2009, c. 344, Pt. E, §2 (AFF). 2009, c. 652, Pt. A, §47 (AMD). 2011, c. 225, §3 (AMD). 2015, c. 169, §3 (AMD).

Subchapter 3: LICENSING

§18131. GENERAL QUALIFICATIONS

An applicant for a license under this subchapter must submit a properly completed application on forms furnished by the board, together with the fee established under section 18143. [2009, c. 344, Pt. C, §3 (NEW); 2009, c. 344, Pt. E, §2 (AFF).]

SECTION HISTORY

2009, c. 344, Pt. C, §3 (NEW). 2009, c. 344, Pt. E, §2 (AFF).

§18132. MASTER OIL BURNER TECHNICIAN OR SOLID FUEL TECHNICIAN

1. Scope of license. The permitted activities for a person licensed as a master oil burner technician or master solid fuel technician are as follows.

A. A master oil burner technician may install, clean, service, alter or repair oil burning equipment and must hold one or more of the following authorities: number one and number 2 oils up to 15 gallons per hour; number one and number 2 oils over 15 gallons per hour; number 4, number 5 and number 6 oils; number one to number 6 oils; and pellet-fired central heating appliances. [2015, c. 169, §4 (NEW).]

B. A master solid fuel technician may install, clean, service, alter or repair solid fuel burning equipment. [2015, c. 169, §4 (NEW).]

[2015, c. 169, §4 (AMD) .]

2. Professional qualifications. Each applicant for a master oil burner or solid fuel license must pass an examination approved by the board and meet the following qualifications:

A. The applicant must demonstrate 4 years of licensed practical experience as an apprentice oil burner technician or solid fuel technician or a journeyman oil burner technician or solid fuel technician and evidence that the licensed practical experience for at least 2 of those 4 years was as a licensed journeyman oil burner technician or solid fuel technician or other requirements the board may establish. Courses approved by the board that apply to a journeyman license cannot be applied toward the requirements for a master license. [2015, c. 169, §4 (AMD).]

B. [2015, c. 169, §4 (RP).]

An out-of-state applicant must present satisfactory evidence to the board of experience in installing, cleaning, servicing, altering and repairing oil or solid fuel burning equipment.

[2015, c. 169, §4 (AMD) .]

SECTION HISTORY

2009, c. 344, Pt. C, §3 (NEW). 2009, c. 344, Pt. E, §2 (AFF). 2015, c. 169, §4 (AMD).

§18133. JOURNEYMAN OIL BURNER TECHNICIAN OR SOLID FUEL TECHNICIAN

1. Scope of license. The permitted activities for a person licensed as a journeyman oil burner technician or journeyman solid fuel technician are as follows.

A. A journeyman oil burner technician, under the indirect supervision of, or in the employ of, a master oil burner technician may install, clean, service, alter or repair oil burning equipment and must hold one or more of the following authorities: number one and number 2 oils up to 15 gallons per hour; number one and number 2 oils over 15 gallons per hour; number 4, number 5 and number 6 oils; number one to number 6 oils; and pellet-fired central heating appliances. The supervising or employing master oil burner technician must hold at least the same authority as the journeyman oil burner technician.

[2015, c. 169, §5 (NEW).]

B. A journeyman solid fuel technician, under the indirect supervision of, or in the employ of, a master solid fuel technician, may install, clean, service, alter or repair solid fuel burning equipment. [2015, c. 169, §5 (NEW).]

[2015, c. 169, §5 (AMD) .]

2. Professional qualifications. Each applicant for a journeyman oil burner or solid fuel license must pass an examination approved by the board and must meet one of the following qualifications:

A. One year of licensed practical experience as an apprentice oil burner technician or solid fuel technician; [2015, c. 169, §5 (AMD).]

B. Six months of licensed practical experience as an apprentice oil burner technician or solid fuel technician and completion of a board-approved oil burner or solid fuel technician course at a community college, career and technical education center or career and technical education region or a comparable institute in the State or another state consisting, at a minimum, of 160 hours of study, of which at least 75 hours are made up of laboratory work on oil burning equipment and related systems; or [2017, c. 210, Pt. I, §1 (AMD).]

C. Successful completion of a minimum one-year accredited heating course at a community college in this State consisting at a minimum of 320 hours of study, of which at least 150 hours are made up of laboratory work on oil or solid fuel burning equipment and related systems. [2015, c. 169, §5 (AMD).]

An out-of-state applicant must present satisfactory evidence to the board of experience in installing, cleaning, servicing, altering and repairing oil and solid fuel burning equipment.

[2017, c. 210, Pt. I, §1 (AMD) .]

SECTION HISTORY

2009, c. 344, Pt. C, §3 (NEW). 2009, c. 344, Pt. E, §2 (AFF). 2015, c. 169, §5 (AMD). 2017, c. 210, Pt. I, §1 (AMD).

§18134. APPRENTICE OIL AND SOLID FUEL BURNING TECHNICIAN

1. Scope of license.

[2015, c. 169, §6 (RP) .]

1-A. Scope of license. The permitted activities for a person licensed as an apprentice oil burner technician or apprentice solid fuel technician are as follows.

A. An apprentice oil burner technician may:

- (1) Assist in making oil installations and repairing and servicing of oil burning equipment under the direct supervision of a master or journeyman oil burner technician who holds the same or higher authority. License authorities include: number one and number 2 oils up to 15 gallons per hour; number one and number 2 oils over 15 gallons per hour; number 4, number 5 and number 6 oils; number one to number 6 oils; and pellet-fired central heating appliances;
- (2) Bleed an oil burner without direct supervision. If the oil burner fails to operate after bleeding, the apprentice shall refer the problem to a journeyman oil burner technician or master oil burner technician; and
- (3) Clean oil burning equipment without direct supervision if the apprentice has either successfully completed at least 160 hours of training approved by the board or completed at least one year of supervised oil burner work experience. [2015, c. 169, §7 (NEW).]

B. An apprentice solid fuel technician may:

- (1) Assist in making solid fuel installations and repairing and servicing of solid fuel burning equipment under the direct supervision of a master or journeyman solid fuel technician; and
- (2) Clean solid fuel burning equipment without direct supervision if the apprentice has either successfully completed at least 160 hours of training approved by the board or completed at least one year of supervised solid fuel work experience. [2015, c. 169, §7 (NEW).]

[2015, c. 169, §7 (NEW) .]

SECTION HISTORY

2009, c. 344, Pt. C, §3 (NEW). 2009, c. 344, Pt. E, §2 (AFF). 2015, c. 169, §§6, 7 (AMD).

§18134-A. EXCEPTION; BLEEDING OF A RESIDENTIAL HOME HEATING OIL BURNER

Notwithstanding section 18102, a home heating oil delivery driver may bleed a residential home heating oil burner without direct supervision if the delivery driver has documentation of having completed a board-approved training course in bleeding oil burners. If the oil burner fails to operate after bleeding, the delivery driver shall refer the problem to a journeyman oil and solid fuel burning technician or master oil and solid fuel burning technician. [2017, c. 288, Pt. C, §3 (AMD).]

SECTION HISTORY

2015, c. 207, §1 (NEW). 2017, c. 288, Pt. C, §3 (AMD).

§18135. PROPANE AND NATURAL GAS TECHNICIAN

1. Scope of license. A propane and natural gas technician may install, repair or service propane or natural gas equipment and must be authorized in one or more of the following authorities:

A. Appliance connection and service, which permits the technician to install and service propane and natural gas appliances up to 500,000 BTUs per appliance; [2009, c. 344, Pt. C, §3 (NEW); 2009, c. 344, Pt. E, §2 (AFF).]

B. Delivery, which permits the technician to deliver propane, either by liquid transfer into a stationary container on the property of the consumer or by placing a portable container on the property of the consumer; [2009, c. 344, Pt. C, §3 (NEW); 2009, c. 344, Pt. E, §2 (AFF).]

C. Large equipment connection and service, which permits the technician to install and service propane and natural gas appliances over 500,000 BTUs per appliance; [2009, c. 344, Pt. C, §3 (NEW); 2009, c. 344, Pt. E, §2 (AFF).]

D. Plant operation, which permits the technician to work at a propane facility as defined in NFPA standards, Number 58; or [2009, c. 344, Pt. C, §3 (NEW); 2009, c. 344, Pt. E, §2 (AFF).]

E. Tank setting and outside piping, which permits the technician to set and maintain propane tanks and outside piping. [2009, c. 344, Pt. C, §3 (NEW); 2009, c. 344, Pt. E, §2 (AFF).]

[2017, c. 210, Pt. I, §2 (AMD) .]

2. Professional qualifications. Each applicant for a propane and natural gas technician license must pass an examination approved by the board and meet one of the following qualifications:

A. Successful completion of the certified employee training program of a national propane gas association; or [2009, c. 344, Pt. C, §3 (NEW); 2009, c. 344, Pt. E, §2 (AFF).]

B. Successful completion of a board-approved propane or natural gas course at a Maine community college, career and technical education center or career and technical education region or a comparable institute of this State or another state and passage of an examination approved by the board. [2009, c. 344, Pt. C, §3 (NEW); 2009, c. 344, Pt. E, §2 (AFF).]

An out-of-state applicant must present satisfactory evidence to the board of experience in installing, cleaning, servicing, altering and repairing propane and natural gas burning equipment.

[2017, c. 210, Pt. I, §2 (AMD) .]

SECTION HISTORY

2009, c. 344, Pt. C, §3 (NEW). 2009, c. 344, Pt. E, §2 (AFF). 2017, c. 210, Pt. I, §2 (AMD).

§18136. PROPANE AND NATURAL GAS HELPER

A propane and natural gas helper may assist in making propane and natural gas installations and repairing and servicing of propane and natural gas equipment under the direct supervision of a propane and natural gas technician who has the same authority as described under section 18135, subsection 1 as the supervising propane and natural gas technician. [2009, c. 344, Pt. C, §3 (NEW); 2009, c. 344, Pt. E, §2 (AFF).]

SECTION HISTORY

2009, c. 344, Pt. C, §3 (NEW). 2009, c. 344, Pt. E, §2 (AFF).

§18137. TEMPORARY LICENSE; PLANT OPERATOR OR DELIVERY TECHNICIAN

1. Scope of license. A temporary license may be issued to a plant operator or delivery technician to practice as follows:

A. Authority to practice as a plant operator is restricted to work at a propane facility as defined in NFPA standards, Number 58; and [2009, c. 344, Pt. C, §3 (NEW); 2009, c. 344, Pt. E, §2 (AFF).]

B. Authority to practice as a delivery technician is restricted to the delivery of propane, either by liquid transfer into a stationary container on the property of a consumer or by placing a portable container on the property of a consumer. [2009, c. 344, Pt. C, §3 (NEW); 2009, c. 344, Pt. E, §2 (AFF).]

[2009, c. 344, Pt. C, §3 (NEW); 2009, c. 344, Pt. E, §2 (AFF) .]

2. License term. An applicant for a temporary plant operator or delivery technician license must apply for a temporary plant operator or delivery technician license within 90 days after first performing the functions listed in subsection 1 and may be issued a license for a 1-year term, which may not be renewed. A new temporary plant operator or delivery technician license may not be issued within 3 years following the date of issuance of the previous temporary plant operator or delivery technician license.

[2009, c. 344, Pt. C, §3 (NEW); 2009, c. 344, Pt. E, §2 (AFF) .]

SECTION HISTORY

2009, c. 344, Pt. C, §3 (NEW). 2009, c. 344, Pt. E, §2 (AFF).

§18138. OIL ENERGY AUDITOR

1. Scope of license. An oil energy auditor's privileges to practice are restricted to the performance of combustion safety and efficiency testing on oil-fired space-heating equipment or water-heating equipment to ensure health and safety standards and do not include any adjustment of oil-fired space-heating equipment or water-heating equipment.

[2017, c. 210, Pt. I, §3 (AMD) .]

2. Professional qualifications. An oil energy auditor must provide to the board, at a minimum, satisfactory evidence of relevant training and written and field certification that conform to standards established by a nationally recognized building performance industry certification and quality assurance program, the equivalent residential energy auditor certification program in the State or an equivalent training and education program as determined by the board.

[2017, c. 210, Pt. I, §3 (AMD) .]

SECTION HISTORY

2009, c. 344, Pt. C, §3 (NEW). 2009, c. 344, Pt. E, §2 (AFF). 2017, c. 210, Pt. I, §3 (AMD).

§18139. PROPANE AND NATURAL GAS ENERGY AUDITOR

1. Scope of license. A propane energy auditor's privileges are restricted to the performance of combustion safety and efficiency testing on natural gas-fired or propane gas-fired space-heating equipment or water-heating equipment to ensure health and safety standards and do not include any adjustment of natural or propane gas-fired space-heating equipment or water-heating equipment.

[2017, c. 210, Pt. I, §4 (AMD) .]

2. Professional qualifications. A propane energy auditor must provide to the board, at a minimum, satisfactory evidence of relevant training and written and field certification that conform to standards established by a nationally recognized building performance industry certification and quality assurance program, the equivalent residential energy auditor certification program in the State or an equivalent training and education program as determined by the board.

[2017, c. 210, Pt. I, §4 (AMD) .]

SECTION HISTORY

2009, c. 344, Pt. C, §3 (NEW). 2009, c. 344, Pt. E, §2 (AFF). 2017, c. 210, Pt. I, §4 (AMD).

§18140. TANK INSTALLER

1. Scope of license. A tank installer's privileges to practice are restricted to installing outside residential heating oil tanks at manufactured housing as defined by Title 10, section 9002, subsection 7, paragraph A.

[2017, c. 210, Pt. I, §5 (AMD) .]

2. Issuance of license. The following provisions govern the issuance of a tank installer's license.

A. A tank installer's license may be issued to:

- (1) A licensed manufactured housing mechanic as defined in Title 10, section 9002; or
- (2) The owner of a manufactured housing dealership for the purpose of installing heating oil tanks at manufactured housing that has been sold by the owner. The license is revoked upon the owner ceasing to operate as a manufactured housing dealer. [2017, c. 210, Pt. I, §5 (AMD) .]

B. A tank installer's license may be issued jointly to a licensed manufactured housing dealer, as defined in Title 10, section 9002, and an individual employee of the dealer who is named as the corecipient of the joint tank installer's license. The corecipient dealer and employee are restricted to installing heating oil tanks at manufactured housing that was sold by the dealer. The joint tank installer's license is revoked upon termination of the employee named as the corecipient of the joint tank installer's license from the employ of the dealer. [2017, c. 210, Pt. I, §5 (AMD) .]

[2017, c. 210, Pt. I, §5 (AMD) .]

3. Professional qualifications. A tank installer must provide satisfactory evidence to the board of completion of a board-approved training program of at least 4 hours for proper installation of an outside oil tank.

[2017, c. 210, Pt. I, §5 (AMD) .]

SECTION HISTORY

2009, c. 344, Pt. C, §3 (NEW). 2009, c. 344, Pt. E, §2 (AFF). 2017, c. 210, Pt. I, §5 (AMD).

§18141. WOOD PELLET TECHNICIAN

A wood pellet technician's privileges to practice are restricted to cleaning the ash pan, cleaning the burn pot, scraping and cleaning the distribution tubes, emptying fines from the collection box and cleaning the fan. [2017, c. 210, Pt. I, §6 (AMD).]

SECTION HISTORY

2009, c. 344, Pt. C, §3 (NEW). 2009, c. 344, Pt. E, §2 (AFF). 2017, c. 210, Pt. I, §6 (AMD).

§18142. LICENSURE; INSTALLATION AND MAINTENANCE STANDARDS; DISPENSING STATIONS

The following licensing, maintenance and installation standards apply to dispensing stations operating in the State. [2009, c. 344, Pt. C, §3 (NEW); 2009, c. 344, Pt. E, §2 (AFF).]

1. License required. An application for licensure of a dispensing station or self-service dispensing station must be made by the owner and, if approved by the board, the license must be issued in the name of the owner.

[2009, c. 344, Pt. C, §3 (NEW); 2009, c. 344, Pt. E, §2 (AFF) .]

2. Responsibilities. The owner of a dispensing station or self-serving dispensing station is responsible for the following.

A. A dispensing station operating in the State must comply with section 18107 and the standards and rules adopted by the board, including, but not limited to, NFPA standards, Numbers 54 and 58, and amendments to and replacements of those standards. [2009, c. 344, Pt. C, §3 (NEW); 2009, c. 344, Pt. E, §2 (AFF).]

B. The on-site operator of a dispensing station must be trained to be the limited operator of the facility. The limited operator is responsible for training other dispensing station employees and documenting that training. The training must include the use of a manual prepared by a regional propane gas association, a video prepared by a national propane gas association or equivalent materials approved by the board. The training documentation must be kept at the dispensing station. [2009, c. 344, Pt. C, §3 (NEW); 2009, c. 344, Pt. E, §2 (AFF).]

C. The owner of a dispensing station must file a new application for licensure with the board within 30 days when:

(1) A dispensing station is relocated; or

(2) A dispensing station undergoes major repair or renovation. [2009, c. 344, Pt. C, §3 (NEW); 2009, c. 344, Pt. E, §2 (AFF).]

[2009, c. 344, Pt. C, §3 (NEW); 2009, c. 344, Pt. E, §2 (AFF) .]

SECTION HISTORY

2009, c. 344, Pt. C, §3 (NEW). 2009, c. 344, Pt. E, §2 (AFF).

§18143. FEES

The Director of the Office of Professional and Occupational Regulation within the Department of Professional and Financial Regulation may establish by rule fees for purposes authorized under this subchapter in amounts that are reasonable and necessary for their respective purposes, except that the fee for

any one purpose may not exceed \$350 biennially. Rules adopted pursuant to this section are routine technical rules pursuant to Title 5, chapter 375, subchapter 2-A. [2009, c. 344, Pt. C, §3 (NEW); 2009, c. 344, Pt. E, §2 (AFF); 2011, c. 286, Pt. B, §5 (REV).]

SECTION HISTORY

2009, c. 344, Pt. C, §3 (NEW). 2009, c. 344, Pt. E, §2 (AFF). 2011, c. 286, Pt. B, §5 (REV).

§18144. RENEWALS

A license expires on the date set by the Commissioner of Professional and Financial Regulation pursuant to Title 10, section 8003, subsection 4 for the licensing period for which the license was issued. A renewal license may be issued for each ensuing licensing period in the absence of any reason or condition that might warrant the refusal to grant a license upon receipt by the board of the written request of the applicant and the fee for the license set under section 18143. An expired license may be reissued up to 90 days after the date of expiration upon payment of a late fee in addition to the renewal fee as set under section 18143. An individual who submits an application for renewal more than 90 days after the license expiration date is subject to all requirements governing new applicants under this chapter and is subject to a renewal fee, late fee and additional late fee as set under section 18143, except that the board may, in its discretion and giving due consideration to the protection of the public, waive examination if that renewal application is made within 2 years from the date of that expiration. [2009, c. 344, Pt. C, §3 (NEW); 2009, c. 344, Pt. E, §2 (AFF).]

SECTION HISTORY

2009, c. 344, Pt. C, §3 (NEW). 2009, c. 344, Pt. E, §2 (AFF).

The State of Maine claims a copyright in its codified statutes. If you intend to republish this material, we require that you include the following disclaimer in your publication:

All copyrights and other rights to statutory text are reserved by the State of Maine. The text included in this publication reflects changes made through the Second Special Session of the 128th Maine Legislature and is current through November 1, 2018. The text is subject to change without notice. It is a version that has not been officially certified by the Secretary of State. Refer to the Maine Revised Statutes Annotated and supplements for certified text.

The Office of the Revisor of Statutes also requests that you send us one copy of any statutory publication you may produce. Our goal is not to restrict publishing activity, but to keep track of who is publishing what, to identify any needless duplication and to preserve the State's copyright rights.

PLEASE NOTE: The Revisor's Office cannot perform research for or provide legal advice or interpretation of Maine law to the public. If you need legal assistance, please contact a qualified attorney.

02-658
Maine Fuel Board
Rules

Table of Contents

Chapter 1.....Definitions 1

Chapter 2.....Advisory Rulings 3

Chapter 3.....Categories and Responsibilities of Licensure 4

Chapter 4.....Qualifications for Licensure 13

Chapter 5.....Use of Other License Authorities 23

Chapter 6.....Adoption of Standards and Rules 25

Chapter 7.....Modification of Standards 29

Chapter 8.....Installation of Oil Burning Equipment 30

Chapter 9.....Installation of Solid Fuel Burning Equipment 46

Chapter 10.....Chimneys 57

Chapter 11.....Installation of Waste Oil Appliances and Waste Oil Supply Tanks 58

Chapter 12.....Permits for Aboveground and Underground Propane and Natural
Gas Storage Facilities and Rooftop Installations 70

Chapter 13.....Installation of Propane and Natural Gas Burning Equipment..... 72

Appendix A.....Department of Environmental Protection Oil Regulations 84

Appendix B.....Department of Environmental Protection Asbestos Regulations..... 85

Appendix C.....Memorandum of Understanding: Maine Fuel Board and
Plumbers’ Examining Board..... 86

Appendix D.....Memorandum of Understanding: Maine Fuel Board and Electricians’
Examining Board: Hot Water, Steam, Warm Air Heating Systems
and Water Heaters 88

Appendix E.....Emergency Chimney Update Waiver Form..... 89

Appendix F.....Chimney or Fireplace Construction/Installation Disclosure 91

Appendix G.....Vehicle Protection..... 92

Appendix H.....Memorandum of Understanding: Maine Fuel Board and Electricians’
Examining Board: Installation of Mini-split Heat Pumps 93

Appendix I.....Memorandum of Understanding: Oil & Solid Fuel Board and
The Propane and Natural Gas Board: Hot Water or Steam
Heating Systems 94

02 DEPARTMENT OF PROFESSIONAL AND FINANCIAL REGULATION**658 MAINE FUEL BOARD****Chapter 1 DEFINITIONS**

Summary: This Chapter defines specialized terms used in the board's rules and sets forth the scope of practice applicable to licenses and authorities issued by the board.

As used in the board's rules, unless the context otherwise indicates, the following terms have the following meanings:

- 1.1 **Affidavit.** "Affidavit" means a form provided by the board to document an applicant's licensed practical experience. The licensed practical experience must be within the scope of the technician's license authority.
- 1.2 **ASME.** "ASME" means American Society of Mechanical Engineers.
- 1.3 **Board.** "Board" means the Maine Fuel Board including inspectors and administrative staff acting on behalf of the board.
- 1.4 **Board-approved training program.** "Board-approved training program" means a training program approved by the board as qualified to prepare candidates to sit for the examination.
- 1.5 **CETP.** "CETP" means the National Propane Gas Association's Certified Employee Training Program.
- 1.6 **Cleaning of oil, solid fuel or gas equipment.** "Cleaning of oil, solid fuel or gas equipment" means the process of: brushing and vacuuming a heating appliance heat exchanger, warm air furnace, boiler (steam or hot water) flue passages and connectors; lubricating motors and bearings; replacing nozzles, belts, filters, and electrodes; performing combustion efficiency testing; testing; safety controls; and performing any other procedure for cleaning and annual maintenance as described in the manufacturer's instructions.
- 1.7 **Combination unit.** "Combination unit" means a heating appliance that is listed for the use of more than one fuel in the same vessel.
- 1.8 **Combustion efficiency test.** "Combustion efficiency test" means a test conducted to determine efficiency of combustion by measuring the composition and temperature of flue gases as they leave the appliance.
- 1.9 **ENT flexible conduit.** "ENT flexible conduit" means electrical non-metallic tubing.
- 1.10 **GPH.** "GPH" means gallons per hour.
- 1.11 **Installation.** "Installation" means the installation, alteration or repair of oil, solid fuel, propane or natural gas burning equipment, chimneys and fireplaces, including accessory equipment.

- 1.12 **License authority.** “License authority” means the scope of permission granted to service and install various types of oil and solid fuel burning and propane and natural gas equipment.
- 1.13 **Listed.** “Listed” means the determination that a piece of equipment or material meets appropriate standards for specific purposes established by a nationally-recognized testing agency.
- 1.14 **Practical experience.** “Practical experience” means work performed on oil, solid fuel, propane or natural gas burning equipment while holding a valid license issued by the board.
- 1.15 **Self-service dispenser.** “Self-service dispenser” means a user-operated device or system designed to measure and transfer volumes of propane or natural gas into permanently mounted fuel containers on vehicles, which dispenser meets the requirements set forth in 32 MRSA §18142.
- 1.16 **Signing master.** “Signing master” means a licensed Master Oil Burner and/or Solid Fuel Technician who signs a Journeyman or Apprentice application or an application for examination acknowledging employment or supervisory responsibility for the work ethic, performance, and training required of the applicant.
- 1.17 **Supervision.** “Supervision” means the direction and overseeing of the work and performance of a licensed apprentice, journeyman or helper as clarified below:
- 1.17.1 **Direct Supervision:** Supervision which requires that the master, journeyman or propane and natural gas technician be on site with the supervisee at all times.
- 1.17.2 **Indirect Supervision:** Supervision which does not require the master, journeyman or propane and natural gas technician to be on site with the supervisee at all times.
-

STATUTORY AUTHORITY: 32 MRSA §18123(2)

EFFECTIVE DATE:

September 27, 2014 – filing 2014-234

02 DEPARTMENT OF PROFESSIONAL AND FINANCIAL REGULATION**658 MAINE FUEL BOARD****Chapter 2 ADVISORY RULINGS**

Summary: This Chapter sets forth procedures for the consideration and issuance of advisory rulings.

2.1 Authority and Scope

The Board may issue an advisory ruling in accordance with 5 MRSA §9001 concerning the applicability of a statute or rule to existing facts. The Board shall review each request for an advisory ruling to determine whether the requested ruling is appropriate. The Board may, at its discretion, decline to issue an advisory ruling if the question is hypothetical, if there is insufficient information upon which to base a ruling or for any other reason the Board deems proper.

2.2 Submission

A request for an advisory ruling must be submitted to the Board in writing and must set forth in detail all facts pertinent to the question. The Board may require submission of additional information it deems necessary to provide a complete factual background.

2.3 Ruling

The Board shall issue advisory rulings in writing. The advisory ruling must include a statement of facts or assumptions, or both, upon which the ruling is based. The statement, without reference to other documents, must be sufficiently detailed to apprise the reader of the basis of the opinion. The assent of four members of the Board is required for the issuance of an advisory ruling. The ruling must be signed by the Board chair, must be identified specifically as an advisory ruling and must be numbered serially.

2.4 Publication

The Board shall mail the advisory ruling to the requesting party and the Board administrator shall retain a copy. An advisory ruling is a public document and is available for public inspection during the normal working hours of the Board. In addition, the Board may otherwise publish or circulate an advisory ruling as it deems appropriate.

STATUTORY AUTHORITY: 5 MRSA §§ 8051, 9001(4)

EFFECTIVE DATE:

September 27, 2014 – filing 2014-235

02 DEPARTMENT OF PROFESSIONAL AND FINANCIAL REGULATION**658 MAINE FUEL BOARD****Chapter 3 CATEGORIES AND RESPONSIBILITIES OF LICENSURE**

Summary: This Chapter describes the duties, responsibilities and limitations of licensure.

3.1 Master Oil and/or Solid Fuel Burning Technician**3.1.1 License Authorities**

Capabilities for a master oil and/or solid fuel burning technician are limited to the following license authorities:

3.1.1.1 1 & 2 oils up to 15 GPH

3.1.1.2 1 & 2 oils over 15 GPH

3.1.1.3 4, 5, & 6 oils

3.1.1.4 1-6 oils

3.1.1.5 Solid fuel

3.1.2 Responsibility of the Supervising Master

3.1.2.1 By signing an application as supervising master oil and/or solid fuel burning technician, the master oil and/or solid fuel burning technician acknowledges employment or supervisory responsibility for the work ethic, performance, and training required of the applicant regardless of the licensing category. It is the duty of the master oil and/or solid fuel burning technician to inspect personally any installation work performed by any licensee for whom the master oil and/or solid fuel burning technician is responsible at the conclusion of the installation.

3.1.2.2 Whenever the supervising master oil and/or solid fuel burning technician ceases to provide supervision, the supervising master oil and/or solid fuel burning technician must notify the Board and licensee in writing, a copy of which shall be kept in both the applicant's and the supervising master oil and/or solid fuel technician's file.

3.1.2.3 Upon request, the supervising master oil and/or solid fuel burning technician must provide a signed affidavit documenting all practical experience performed by an apprentice or journeyman under the master oil and/or solid fuel burning technician's supervision.

3.1.2.4 A master oil and/or solid fuel burning technician cannot supervise an apprentice oil and/or solid fuel burning technician or journeyman oil and/or

solid fuel burning technician whose license authority exceeds that of the master oil and/or solid fuel burning technician.

- 3.1.2.5 A master oil and/or solid fuel burning technician who sells, contracts, dispatches or subcontracts any work or installation to another master oil and/or solid fuel burning technician or other licensee is responsible for the completion of the installation and the work performed. The master oil and/or solid fuel burning technician contracting the work and the licensee performing the work both have equal responsibility to ensure that all work complies with the Board's rules.

3.1.3 **Combination Oil/Solid Fuel Units**

A master and/or journeyman oil burning technician may clean a combination unit and service and repair the oil burner assembly without direct supervision if he or she is licensed as an apprentice solid fuel technician.

3.2 **Journeyman Oil and/or Solid Fuel Burning Technician**

3.2.1 **Proof of Licensed Practical Experience**

In order for a journeyman oil and/or solid fuel burning technician to progress through the various licensing categories and authorities, documented proof of licensed practical experience must be provided to the Board. It is the responsibility of the licensee to obtain an affidavit from all licensed master oil and/or solid fuel burning technicians who provided supervision as to the dates (day, month, year) of accumulated licensed practical experience to establish his or her eligibility when applying for a master oil and/or solid fuel burning technician license.

3.2.2 **License Authorities**

Capabilities are limited to the following license authorities:

- 3.2.2.1 1 & 2 oils up to 15 GPH
- 3.2.2.2 1 & 2 oils over 15 GPH
- 3.2.2.3 4, 5, & 6 oils
- 3.2.2.4 1-6 oils
- 3.2.2.5 Solid fuel

3.2.3 **Indirect Supervision by a Master Required**

A journeyman oil and/or solid fuel burning technician must at all times be under the indirect supervision of a master oil and/or solid fuel burning technician who accepts full responsibility for the work ethic and performance of the journeyman oil and/or solid fuel burning technician.

3.2.4 **Supervision by a Master Required**

A journeyman oil and/or solid fuel burning technician shall not work on any oil and/or solid fuel burning equipment if for any reason he or she is no longer supervised by a master oil and/or solid fuel burning technician.

3.2.5 **License Authority of Supervising Journeyman vs. Apprentice**

A journeyman oil and/or solid fuel burning technician shall not supervise an apprentice oil and/or solid fuel burning technician whose license authority exceeds that of the journeyman oil and/or solid fuel burning technician.

3.2.6 **Limitation on Number of Apprentices**

A journeyman oil and/or solid fuel burning technician shall not have more than 2 apprentice technicians working under the journeyman's direct supervision at any one time.

3.2.7 **Combination Oil/Solid Fuel Units**

A master or journeyman oil burning technician may clean a combination unit and service and repair the oil burner assembly without direct supervision if he or she is also licensed as an apprentice solid fuel technician.

3.3 **Apprentice Oil and/or Solid Fuel Burning Technician**

3.3.1 **Apprentice Oil Burning Technician**

An apprentice oil burning technician must be under the direct supervision of a journeyman or master oil burning technician at all times while altering, repairing, or installing oil burning equipment.

3.3.1.1 An apprentice oil burning technician may clean oil burning equipment without direct supervision if the licensee has either:

3.3.1.1.1 Successfully completed at least 160 hours of training approved by the Board; or

3.3.1.1.2 Completed at least one year of supervised oil burner experience.

3.3.1.2 An apprentice oil burner technician may also bleed an oil burner without direct supervision. If the oil burner fails to operate properly after bleeding, the apprentice must refer the problem to a journeyman or master licensee. Failure to conform to this requirement may subject the apprentice and the signing master to disciplinary action for servicing oil burning equipment without proper supervision.

3.3.2 **Apprentice Solid Fuel Technician**

An apprentice solid fuel technician must be under the direct supervision of a journeyman or master solid fuel technician at all times while altering, repairing, or installing central solid fuel appliances and accessory equipment. An apprentice solid

fuel technician may clean solid fuel burning equipment without direct supervision as long as that cleaning does not entail control adjustments.

3.3.3 **License Authorities**

Capabilities are limited to the following license authorities:

3.3.3.1 1 & 2 oils up to 15 GPH

3.3.3.2 1 & 2 oils over 15 GPH

3.3.3.3 4, 5, & 6 oils

3.3.3.4 1-6 oils

3.3.3.5 Solid fuel

3.3.4 **Proof of Licensed Practical Experience**

In order for an apprentice oil and/or solid fuel burning technician to progress through the various licensing categories and authorities, documented proof of licensed practical experience must be provided to the Board. It is the responsibility of the licensee to obtain an affidavit from all master oil and/or solid fuel burning technicians as to the dates (day, month, year) of accumulated licensed practical experience to establish his or her eligibility when applying for a higher category or authority of license.

3.3.5 **Supervision by a Journeyman or Master Required**

An apprentice oil and/or solid fuel burning technician shall not work on any oil and/or solid fuel burning equipment if for any reason he or she is no longer supervised by an appropriately-licensed journeyman or master oil and/or solid fuel burning technician.

3.4 **Limited Oil Energy Auditor**

3.4.1 **Limited Scope of Practice**

A limited oil energy auditor is limited to performing combustion safety and efficiency testing on oil-fired space heating or water heating equipment. Limited oil energy auditors shall not make any adjustments to oil-fired space heating or water heating equipment.

3.4.2 **Obtaining Manufacturer's Instructions**

Prior to performing a combustion safety and efficiency test, a limited oil energy auditor must obtain the manufacturer's installation and operating instructions for the specific equipment to be tested.

3.4.3 **Following Manufacturer's Instructions**

A limited oil energy auditor must observe all provisions of the manufacturer's installation and operating instructions when performing a combustion and efficiency test including, but not limited to, any restrictions or limitations relating to equipment access and pipe penetration.

3.4.4 **Test Results**

Combustion efficiency test results must fall within the guidelines contained in the manufacturer's installation and operating instructions. The limited oil energy auditor must provide a copy of the test results to the homeowner and must notify the homeowner and occupant in writing if the test results do not meet the manufacturer's guidelines.

3.5 **Limited Tank Installer**

A limited oil tank installer is limited to installing outside residential oil supply tanks connected to manufactured housing units as set forth in 10 MRSA §9002 (7)(A).

3.6 **Limited Wood Pellet Technician**

A limited wood pellet technician is limited to cleaning the ash pan, cleaning the burn pot, scraping and cleaning the distribution tubes, emptying fines from the collection box and cleaning the fan as set forth in 32 MRSA §18141.

3.7 **Propane and Natural Gas Technician**

3.7.1 **License Authorities**

Capabilities for a Propane and Natural Gas Technician are limited to the following license authorities:

- 3.7.1.1 Appliance Connection and Service
- 3.7.1.2 Delivery
- 3.7.1.3 Large Equipment
- 3.7.1.4 Plant Operation
- 3.7.1.5 Tank Setting and Outside Piping

3.7.2 **Responsibility of Propane and Natural Gas Technician with Delivery Authority**

- 3.7.2.1 When delivering propane to a dispensing station, the delivery technician must verify that the dispensing station has a valid license prior to completing the delivery. If the dispensing station is not licensed, the delivery shall not be completed until such time as the dispenser has been properly licensed.
- 3.7.2.2 Any ASME container that does not have a data plate or has a plate that is not legible will be considered to be out of compliance and may not be filled.

- 3.7.2.3 When delivering propane or natural gas to a customer's location, the delivery technician must notify the tank owner and/or homeowner in writing of any code violations related to the tank installation.

If a dangerous condition exists, in the opinion of the delivery technician, no delivery shall be made until the condition is made safe.

3.7.3 **Responsibility of the Supervising Propane and Natural Gas Technician**

- 3.7.3.1 It is the responsibility of the supervising propane and natural gas technician to supervise directly any work performed by the propane and natural gas helper for whom the propane and natural gas technician is responsible.
- 3.7.3.2 A supervising propane and natural gas technician shall not supervise a propane and natural gas helper outside the scope of his/her license authority.
- 3.7.3.3 A propane and natural gas technician who sells, contracts, dispatches or subcontracts any work or installation to another propane and natural gas technician is responsible for the completion of the installation and the work performed. The propane and natural gas technician contracting the work and the licensee performing the work both have equal responsibility to ensure that all work complies with the Board's rules.
- 3.7.3.4 A licensed propane and natural gas technician may perform duties outside of his license authority while working under the direct supervision of a propane and natural gas technician having that authority.

3.8 **Propane and Natural Gas Helper**

3.8.1 **Direct Supervision by a Technician Required**

A propane and natural gas helper may assist in making propane and natural gas installations. A propane and natural gas helper must be under the direct supervision of a propane and natural gas technician at all times while altering, repairing, or installing propane and natural gas burning equipment.

3.8.2 **License Authorities**

Capabilities are limited to the following license authorities of the supervising propane and natural gas technician:

- 3.8.2.1 Appliance Connection and Service;
- 3.8.2.2 Delivery;
- 3.8.2.3 Large Equipment;
- 3.8.2.4 Plant; and
- 3.8.2.5 Tank Setting and Outside Piping.

3.9 Large Equipment Connection and Service Technician

A large equipment connection and service technician may install and service propane and natural gas appliances and piping within the scope of NFPA 54 to appliances over 500,000 BTUs per appliance.

3.10 Appliance connection and service technician

An appliance connection and service technician may perform the following tasks:

- 3.10.1 Install and repair all inside or outside piping from the outlet of the valve, meter, second stage regulator or 2psi regulator based upon whichever is closest to the customer's piping, to the gas utilization equipment, and;
- 3.10.2 Install, adjust and repair all customer-owned gas utilization equipment including the fuel train, electrical systems and venting systems that are associated with the correct operation of the equipment.

3.11 Delivery Technician

A delivery technician may perform the following tasks:

- 3.11.1 Inspect and maintain propane delivery vehicles;
- 3.11.2 Fill propane containers and cargo tanks on bulk delivery trucks;
- 3.11.3 Make propane deliveries of either containers or bulk propane to customer locations; and
- 3.11.4 Perform a leak check and re-light pilots after interruption of service.

3.12 Tank Setter/Outside Piping Technician

A tank setter/outside piping technician may perform the following tasks:

- 3.12.1 Determine the correct location of and set aboveground or underground propane tanks;
- 3.12.2 Install or maintain pumps or vaporizers associated with product delivery on an end user's site;
- 3.12.3 Install or repair aboveground or underground piping, risers, valves, regulators or other fittings up to the outlet of the valve, meter, or second stage regulator based on whichever is closest to the customer-owned piping;
- 3.12.4 Transport propane containers solely for the purpose of setting a tank at a customer location;
- 3.12.5 Construct bulk plants and dispensing stations and associated piping; and
- 3.12.6 Perform a leak check and re-light pilots after an interruption of service.

3.13 Plant Operator

A plant operator may perform the following tasks:

- 3.13.1 Fill and remove propane from railroad cars, tractor-trailers, trucks, transports or bobtails as required;
- 3.13.2 Fill and remove propane from storage containers, and repair propane storage containers as needed including valves and gauges; and
- 3.13.3 Perform requalification testing on storage tanks as necessary.

3.14 Temporary License; Plant Operator or Delivery Technician

A person licensed as a temporary plant operator or delivery technician as set forth in 32 MRSA §18137 is limited to the following license authorities:

- 3.14.1 Plant Operation; and
- 3.14.2 Delivery.

3.15 Limited Propane and Natural Gas Energy Auditor

3.15.1 Limited Scope of Practice

A limited propane and natural gas energy auditor is limited to performing combustion safety and efficiency testing on natural gas-fired or propane gas-fired space heating or water heating equipment. Limited propane and natural gas energy auditors may not make any adjustments to natural gas-fired or propane gas-fired space heating or water heating equipment.

3.15.2 Obtaining Manufacturer's Instructions

Prior to performing a combustion safety and efficiency test, a limited propane and natural gas energy auditor must obtain the manufacturer's installation and operating instructions for the specific equipment to be tested.

3.15.3 Following Manufacturer's Instructions

A limited propane and natural gas energy auditor must observe all provisions of the manufacturer's installation and operating instructions when performing a combustion and efficiency test including, but not limited to, any restrictions or limitations relating to equipment access and pipe penetration.

3.15.4 Test Results

Combustion efficiency test results must fall within the guidelines contained in the manufacturer's installation and operating instructions. The limited propane and natural gas energy auditor must provide a copy of the test results to the homeowner and must notify the homeowner and occupant in writing if the test results do not meet the manufacturer's guidelines.

STATUTORY AUTHORITY: 32 MRSA §18123(2)

EFFECTIVE DATE:

September 27, 3014 – filing 2014-236

02 DEPARTMENT OF PROFESSIONAL AND FINANCIAL REGULATION**658 MAINE FUEL BOARD****Chapter 4 QUALIFICATIONS FOR LICENSURE**

Summary: This Chapter sets forth qualifications for licensure and describes the application and examination process.

4.1 Master Oil and/or Solid Fuel Burning Technician**4.1.1 Application**

Applications for examination and/or licensure as a master oil and/or solid fuel burning technician under 32 MRSA §18132 must be submitted on a form provided by the Board and must be accompanied by the license fee set forth in Chapter 10, Section 5(17-A) of the rules of the Office of Professional and Occupational Regulation, entitled “Establishment of License Fees.”

4.1.2 Examination

To qualify to sit for the master oil and/or solid fuel burning technician examination, an applicant must meet the work experience requirements set forth in 32 MRSA §18132(2)(A).

4.1.2.1 To be eligible for a 1 & 2 over 15 gph oils license, the applicant must pass the examinations for both the 1 & 2 oils up to 15 gph and the 1 & 2 oils over 15 gph.

4.1.2.2 To be eligible for a 1-6 oils license, the applicant must pass the examinations for both the 1 & 2 up to 15 gph oils and the 4, 5, & 6 oils.

4.1.3 Documentation of Licensed Experience

An in-state applicant must provide documentation of licensed experience on an affidavit provided by the Board. The affidavit must be completed and signed by an appropriately licensed master oil and/or solid fuel burning technician attesting to the supervision of the applicant’s practical experience.

4.1.4 Out-of-State Applicants

An out-of-state applicant must provide documentation of employment as an oil and/or solid fuel burning technician. This documentation must include four years of actual work performed on oil burning equipment or solid fuel burning equipment.

4.2 Journeyman Oil and/or Solid Fuel Burning Technician

4.2.1 Application

Applications for examination and/or licensure as a journeyman oil and/or solid fuel burning technician under 32 MRSA §18133 must be submitted on a form provided by the Board and must be accompanied by the license fee set forth in Chapter 10, Section 5(17-A) of the rules of the Office of Professional and Occupational Regulation, entitled “Establishment of License Fees.”

4.2.2 Examination – Journeyman Oil Burner Technician

4.2.2.1 An applicant who applies for licensure pursuant to 32 MRSA §18133(2)(A) (one year apprenticeship) must complete the apprenticeship before applying and sitting for examination. An applicant who applies for licensure pursuant to 32 MRSA §18133(2)(B) (six month apprenticeship and completion of course) may apply and sit for examination upon successful completion of the requisite education, prior to completion of the apprenticeship. An applicant who applies for licensure pursuant to 32 MRSA §18133(2)(C) (one-year course) must complete the requisite education before applying and sitting for examination.

4.2.2.1.1 To be eligible for a 1 & 2 over 15 gph oils license, the applicant must pass the examination for both the 1 & 2 up to 15 gph oils and the 1 & 2 over 15 gph oils.

4.2.2.1.2 To be eligible for a 1-6 oils license, the applicant must pass the examination for both the 1 & 2 up to 15 gph oils and the 4, 5, & 6 oils.

4.2.3 Examination – Journeyman Solid Fuel Technician

An applicant who applies for licensure pursuant to 32 MRSA §18133(2)(A) (one year apprenticeship) must complete the apprenticeship before applying and sitting for examination. An applicant who applies for licensure pursuant to 32 MRSA §18133(2)(B) (six month apprenticeship and completion of course) may apply and sit for examination upon successful completion of the requisite education, prior to completion of the apprenticeship. An applicant who applies for licensure pursuant to 32 MRSA §18133(2)(C) (one-year course) must complete the requisite education before applying and sitting for examination.

4.2.4 Documentation of Licensed Experience

An in-state applicant must provide documentation of licensed experience on an affidavit provided by the Board. The affidavit must be completed and signed by an appropriately licensed master oil and/or solid fuel burning technician attesting to the supervision of the applicant’s practical experience.

4.2.5 **Out-of-State Applicants**

An out-of-state applicant must provide documentation of employment as an oil and/or solid fuel burning technician. This documentation must include one year of actual work performed on oil burning equipment or solid fuel burning equipment.

4.3 **Apprentice Oil and/or Solid Fuel Burning Technician**

4.3.1 **Application**

Applications for licensure as an apprentice oil and/or solid fuel burning technician under 32 MRSA §18134 must be submitted on a form provided by the Board and must be accompanied by the license fee set forth in Chapter 10, Section 5(17-A) of the rules of the Office of Professional and Occupational Regulation, entitled “Establishment of License Fees.”

4.3.2 **Signature of Master Required**

The apprentice oil and/or solid fuel burning technician license application must be signed by an appropriately licensed master oil and/or solid fuel burning technician. By signing the application, the signing master oil and/or solid fuel burning technician acknowledges employment or supervisory responsibility for the work ethic, performance, and training required of the apprentice oil and/or solid fuel burning technician.

4.3.3 **License Authority of Signing Master**

The signing master oil and/or solid fuel technician’s authority must be equal to or higher than the requested authority of the apprentice oil and/or solid fuel burning license. For example, if the authority of the signing master is 1 & 2 oils up to 15 gallons, the apprentice oil and/or solid fuel burning technician may not perform work beyond that authority. Any licensed master or journeyman oil and/or solid fuel burning technician may supervise an apprentice oil and/or solid fuel burning technician, provided the master or journeyman oil and/or solid fuel burning technician has equal to or higher authority than the apprentice oil and/or solid fuel burning technician.

4.4 **Limited Oil Energy Auditor**

4.4.1 **Application**

Applications for licensure as a limited oil energy auditor under 32 MRSA §18138 must be submitted on a form provided by the Board and must be accompanied by the license fee set forth in Chapter 10, Section 5(17-A) of the rules of the Office of Professional and Occupational Regulation, entitled “Establishment of License Fees.”

4.4.2 **Qualifications**

In order to qualify for a limited oil energy auditor license, an applicant must provide evidence of satisfactory completion of the Certified Building Analyst 1 certification test and field examination offered by the Building Performance Institute, the equivalent Maine residential energy auditor certification program, or an equivalent training program acceptable to the Board.

4.4.3 **Limitation on Use of Experience**

Experience gained as a limited oil energy auditor shall not be used to satisfy the prerequisites for licensure as a master or journeyman oil and solid fuel burning technician.

4.5 **Limited Tank Installer**

4.5.1 **Application**

Applications for licensure as a limited tank installer under 32 MRSA §18140 must be submitted on a form provided by the Board and must be accompanied by the license fee set forth in Chapter 10, Section 5(17-A) of the rules of the Office of Professional and Occupational Regulation, entitled “Establishment of License Fees.”

4.5.2 **Qualifications**

In order to qualify for a limited tank installer’s license, an applicant must hold and maintain either a manufactured housing mechanic’s license or a manufactured housing dealer’s license issued pursuant to 10 M.R.S.A. Chapter 951 or be a manufactured housing dealer employee who has satisfactorily completed a training program that includes at least 4 hours on installation of outside oil tanks, as approved by the Board.

4.5.3 **Training Program – One Year Limit**

The training program approved by the Board is valid for one year from successful completion. If an applicant fails to apply for a license within one year from completion of a training program approved by the Board, the applicant must retake the training program.

4.5.4 **Limitation on Use of Experience**

Experience gained as a limited tank installer shall not be used to satisfy the prerequisites for licensure as a master or journeyman oil and solid fuel burning technician’s license.

4.6 **Limited Wood Pellet Technician**

4.6.1 **Application**

Applications for licensure as a limited wood pellet technician under 32 MRSA §18141 must be submitted on a form provided by the Board and must be accompanied by the license fee set forth in Chapter 10, Section 5(17-A) of the rules of the Office of Professional and Occupational Regulation, entitled “Establishment of License Fees.”

4.6.2 **Limitation on Use of Experience**

Experience gained as a limited wood pellet technician may not be used to satisfy the prerequisites for licensure as a master or journeyman oil and solid fuel burning technician’s license.

4.7 Propane and Natural Gas Technician

4.7.1 Application

Applications for licensure as a propane and natural gas technician under 32 MRSA §18135 must be submitted on a form provided by the Board and must be accompanied by the license fee set forth in Chapter 10, Section 5(17-A) of the rules of the Office of Professional and Occupational Regulation, entitled “Establishment of License Fees.”

4.7.2 Qualification for Licensure via CETP

To qualify for licensure by successfully completing CETP as set forth in 32 MRSA §18135(2)(A), an applicant must submit the wall certificate issued by National Propane Gas Association to the Board as proof of completion. The wall certificate submitted must be specific to the license authority requested.

4.7.3 Qualification for Licensure by Examination

To qualify for licensure by examination as set forth in 32 MRSA §18135(2)(B), an applicant must submit proof of successful completion of the requisite education to the Board.

4.7.4 Large Equipment Authority

To qualify for licensure as a propane and natural gas technician with the large equipment connection and service technician authority, an applicant must hold a license as a propane and natural gas technician with the appliance connection and service technician authority and:

4.7.4.1 Pass the large equipment connection and service technician examination;
or

4.7.4.2 Successfully complete the large equipment connection and service technician CETP certification.

4.8 Propane and Natural Gas Helper

4.8.1 Application

Applications for licensure as a propane and natural gas helper under 32 MRSA §18136 must be submitted on a form provided by the Board and must be accompanied by the license fee set forth in Chapter 10, Section 5(17-A) of the rules of the Office of Professional and Occupational Regulation, entitled “Establishment of License Fees.”

4.8.2 Signature of Technician Required

The propane and natural gas helper license application must be signed by an appropriately licensed propane and natural gas technician.

4.8.3 Minimum Age

The minimum age for eligibility for a helper license is 18 years old.

4.9 Temporary License; Plant Operator or Delivery Technician

4.9.1 Application

Applications for a temporary license as a plant operator or delivery technician under 32 MRSA §18137 must be submitted on a form provided by the Board and must be accompanied by the license fee set forth in Chapter 10, Section 5(17-A) of the rules of the Office of Professional and Occupational Regulation, entitled “Establishment of License Fees.”

4.9.2 Affidavit Required

The temporary license application must include a completed affidavit provided by the Board and signed by a licensed propane and natural gas technician with the delivery authority for delivery technician and the plant operator authority for bulk plant operator verifying that the applicant has completed job function training specific to bulk plant operator and/or delivery technician.

4.10 Limited Propane and Natural Gas Energy Auditor

4.10.1 Application

Applications for licensure as a limited propane and natural gas energy auditor under 32 MRSA §18139 must be submitted on a form provided by the Board and must be accompanied by the license fee set forth in Chapter 10, Section 5(17-A) of the rules of the Office of Professional and Occupational Regulation, entitled “Establishment of License Fees.”

4.10.2 Qualifications

In order to qualify for a limited propane and natural gas energy auditor license, an applicant must provide evidence of satisfactory completion of the Certified Building Analyst 1 certification test and field examination offered by the Building Performance Institute, the equivalent Maine residential energy auditor certification program, or an equivalent training program acceptable to the Board.

4.10.3 Limitation on Use of Experience

Experience gained as a limited propane and natural gas energy auditor shall not be used to satisfy the prerequisites for licensure as a propane and natural gas technician.

4.11 Dispensing Station

4.11.1 Application

A dispensing station license application under 32 MRSA §18142 must be submitted on a form provided by the Board and must be accompanied by the license fee set forth in Chapter 10, Section 5(17-A) of the rules of the Office of Professional and Occupational Regulation, entitled “Establishment of License Fees.”

4.11.2 **Signature of Owner and Affidavit of Training Required**

The dispensing station license application must be signed by the owner of the dispensing station equipment and must include a completed affidavit provided by the Board and signed by the gas supplier indicating that the on-site operator of the dispensing station has been trained as required by 32 MRSA §18142(2)(B) to be the limited operator of the facility.

4.11.3 **Minimum Age**

No person under the age of 18 years old shall operate a dispensing station.

4.11.4 **On-Site Limited Operator Required**

Each dispensing station must employ an on-site limited operator who is responsible for training on-site dispensing station operators. The training documentation required will include the Propane Gas Association of New England's dispensing station operator's manual and the National Propane Gas Association Video entitled "Dispensing Propane Safely" or equivalent materials approved by the Board. A record of this training for all operators must be maintained on-site at all times and be available for inspection.

The gas supplier must provide refresher training to the limited operator prior to each license renewal. The training must be documented and signed by the gas supplier indicating that the on-site operator of the dispensing station has been trained. A copy of the training record must remain on site with the dispensing station license.

4.11.5 **Change of Limited Operator**

When a change of limited operator occurs, a change of limited operator application must be submitted on a form provided by the Board and signed by the gas supplier indicating that the on-site operator of the dispensing station has been trained as required by 32 MRSA §18142(2)(B) to be the limited operator of the facility.

4.11.6 **Display of License Required**

A dispensing station license must be conspicuously displayed with the name of the dispensing station, license number and expiration date visible at all times.

4.12 **Self-Service Dispensing Station**

4.12.1 **Application**

A self-service dispensing station license application under 32 MRSA §18142 must be submitted on a form provided by the Board and must be accompanied by the license fee set forth in Chapter 10, Section 5(17-A) of the rules of the Office of Professional and Occupational Regulation, entitled "Establishment of License Fees."

4.12.2 **Signature of Owner and Affidavit of Training Required**

The dispensing station license application must be signed by the owner of the dispensing station equipment and must include a completed affidavit provided by the Board and signed by the gas supplier indicating that the on-site operator of the dispensing station has been trained as required by 32 MRSA §18142(2)(B) to be the limited operator of the facility.

4.12.3 **Trained Operator on Duty Required**

A self-service dispensing station must have at least one trained operator on duty while the station is open for business. The operator's primary function shall be to supervise, observe, and control the dispensing of propane and natural gas while said products are actually being dispensed. The trained operator on duty shall not be under the age of 18 years old.

4.12.4 **Responsibilities of Operator on Duty**

It shall be the responsibility of the operator on duty to:

- 4.12.4.1 Prevent the dispensing of propane and natural gas into portable containers;
- 4.12.4.2 Prevent the use of hose nozzle valve latch-open devices that are not recommended by the valve manufacturer;
- 4.12.4.3 Control sources of ignition; and
- 4.12.4.4 Immediately activate emergency procedures pertaining to the site.

4.12.5 **Change of Operator**

When a change of operator occurs, a change of operator application must be submitted on a form provided by the Board and signed by the gas supplier indicating that the on-site operator of the dispensing station has been trained as required by 32 MRSA §18142(2)(B) to be the operator of the facility.

4.13 **Application for Examination**

4.13.1 **Required Documents and Fee**

Applicants for examination must submit all of the following:

- 4.13.1.1 Completed application;
- 4.13.1.2 The application fee required by Chapter 10, Section 5(17-A) of the Rules of the Office of Professional and Occupational Regulation, entitled "Establishment of License Fees;"
- 4.13.1.3 School certificate(s) (if applicable); and
- 4.13.1.4 Affidavit(s) (if applicable).

4.13.2 **Incomplete or Illegible Applications**

Incomplete or illegible applications will be returned to the applicant together with any attachments.

4.13.3 **Board Approval Required**

Applicants must receive approval from the Board prior to sitting for an examination. Examination scores of applicants who take an examination prior to receiving Board approval will be null and void.

4.14 **Examinations**

4.14.1 **Passing Score; License Application**

The passing score for all examinations is 70%. The Board will mail a license application to a candidate who successfully passes the examination.

4.14.2 **Time Limits**

An examination application will remain valid for a period of 2 years from the date of receipt. If an applicant fails to pass the examination within 2 years of Board approval, the applicant must reapply as a new applicant. If an applicant fails to apply for a license within 2 years from the date of notification of a passing score on the examination, the applicant must reapply as a new applicant and retake the examination.

[NOTE: Refer to the Candidate Informational Bulletin for more information.]

4.15 **Renewal of license**

4.15.1 **Expiration**

All licenses expire 2 years from the date of issuance.

4.15.2 **Eligibility for Renewal**

To renew a license, an applicant must comply with 32 MRSA §18144. A license may be renewed up to 90 days after expiration upon payment of a late fee in addition to the renewal fee.

4.16 **Reinstatement of License**

4.16.1 **More than 90 Days but not more than 2 Years**

Licensees who fail to renew a license for more than 90 days but not more than 2 years from the date of expiration may reinstate as follows:

- 4.16.1.1 Master oil and solid fuel burning technicians, journeyman oil and solid fuel burning technicians and propane and natural gas technicians who qualified for licensure by examination may reinstate the license without taking the examination by filing an application for renewal and by filing and paying the license fee and penalty as set forth in Chapter 10, Section 5(17-A) of

the rules of the Office of Professional and Occupational Regulation, entitled “Establishment of License Fees.”

- 4.16.1.2 Propane and natural gas technicians who qualified for licensure by CETP, limited oil energy auditors, limited propane and natural gas energy auditors, limited tank installers, and limited wood pellet technicians may reinstate the license by filing an application for renewal and by filing and paying the license fee and penalty as set forth in Chapter 10, Section 5(17-A) of the rules of the Office of Professional and Occupational Regulation, entitled “Establishment of License Fees.”
- 4.16.1.3 Dispensing stations may reinstate the license by filing an application for renewal and by filing and paying the license fee and penalty as set forth in Chapter 10, Section 5(17-A) of the rules of the Office of Professional and Occupational Regulation, entitled “Establishment of License Fees.”
- 4.16.1.4 Apprentice oil and solid fuel technicians and propane and natural gas helpers must reapply as a new applicant.

4.16.2 More than 2 Years

- 4.16.2.1 An individual who fails to renew a license for more than 2 years from the date of expiration may obtain a new license by satisfying all of the requirements of 32 MRSA Chapter 139 and the Board’s rules.
- 4.16.2.2 A dispensing station that fails to renew a license for more than 2 years from the date of expiration may obtain a new license by satisfying all of the requirements of 32 MRSA Chapter 139, the Board’s rules and the edition of NFPA 58 or NFPA 52 in effect at the time of application.

STATUTORY AUTHORITY: 32 MRSA §18123(2)

EFFECTIVE DATE:

September 27, 2014 – filing 2014-237

02 DEPARTMENT OF PROFESSIONAL AND FINANCIAL REGULATION**658 MAINE FUEL BOARD****Chapter 5 USE OF OTHER LICENSE AUTHORITIES**

Summary: This chapter sets forth the requirements for licensed master and journeyman oil and solid fuel technicians to gain licensed experience as an apprentice to qualify for an additional license authority. Current license authorities are: 1 & 2 up to 15 gph oils; 1 & 2 over 15 gph oils; 4, 5 & 6 oils; 1–6 oils; and solid fuel.

5.1 Examination in Another License Authority

In order for a licensed journeyman or master oil and solid fuel technician to be eligible to take an examination in another license authority, the applicant must file an examination application on a form provided by the Board accompanied by the license fee set forth in Chapter 10, Section 5(17-A) of the rules of the Office of Professional and Occupational Regulation, entitled “Establishment of License Fees.” The application must include an affidavit attesting to completion of the requisite supervision for the relevant authority as follows:

5.1.1 Journeyman Oil Burner Technician Applying for a Different Authority

A licensed journeyman oil burner technician applying for a journeyman examination for a different authority must provide documented proof of one year of direct supervision by a master holding the authority applied for.

5.1.2 Journeyman Oil Burner Technician Applying for a Journeyman Solid Fuel Authority

A licensed journeyman oil burner technician applying for a journeyman solid fuel examination must provide documented proof of one year of indirect supervision by a master with the solid fuel authority.

5.1.3 Master Oil Burner Technician Applying for a Different Authority

A licensed master oil burner technician applying for a master examination of a different authority must provide documented proof of one year of indirect supervision by a master holding the authority applied for.

5.1.4 Licensed Master Oil Burner Technician Applying for a Master Solid Fuel Authority

A licensed master oil burner technician applying for a master solid fuel examination is automatically qualified to sit for the examination.

5.2 Term of Certain Apprentice Licenses

An apprentice oil and solid fuel technician license issued to a licensed master or journeyman oil and solid fuel technician to gain experience towards an additional authority is co-extensive with the term of the underlying license.

5.3 Waiver of Fees for Certain Apprentice Licenses

The apprentice license fee will be waived for licensed master and journeyman oil and solid fuel technicians gaining licensed experience to qualify for an additional license authority. The applicant will be required to pay the application fee set forth in Chapter 10, Section 5(17-A) of the rules of the Office of Professional and Occupational Regulation, entitled “Establishment of License Fees.”

STATUTORY AUTHORITY: 32 MRSA §18123(2)

EFFECTIVE DATE:

September 27, 2014 – filing 2014-238

02 DEPARTMENT OF PROFESSIONAL AND FINANCIAL REGULATION**658 MAINE FUEL BOARD****Chapter 6 ADOPTION OF STANDARDS AND RULES**

Summary: This Chapter sets forth the standards for installation of any oil and solid fuel burning equipment, propane and natural gas equipment, chimneys, fireplaces and vents.

6.1 Adopted Standards

The Maine Fuel Board adopts and incorporates by reference into this Chapter the following editions of technical standards or codes. All installations and servicing of any oil and solid fuel burning equipment, propane and natural gas equipment, and the installation of chimneys, fireplaces and vents must comply with applicable requirements of these technical standards and codes, as well as any additional standards imposed by Title 32 MRSA Chapter 139 and the Board's rules.

- 6.1.1 NFPA #30A, *Motor Fuel Dispensing Facilities and Repair Garages* (2012 edition);
- 6.1.2 NFPA #31, *Standard for the Installation of Oil Burning Equipment* (2011 edition);
- 6.1.3 NFPA #52, *Vehicular Gaseous Fuel Systems Code* (2010 edition);
- 6.1.4 NFPA #54, *National Fuel Gas Code* (2012 edition);
- 6.1.5 NFPA #55, *Compressed Gases and Cryogenic Fluids* (2010 edition);
- 6.1.6 NFPA #58, *Liquefied Petroleum Gas Code* (2011 edition);
- 6.1.7 NFPA #59, *Utility LP-Gas Plant Code* (2012 edition);
- 6.1.8 NFPA #59A, *Standard for the Protection, Storage & Handling of Liquefied Natural Gas (LNG)* (2009 edition);
- 6.1.9 NFPA #70, *National Electrical Code* (2011 edition);
- 6.1.10 NFPA #88A, *Parking Structures* (2011 edition);
- 6.1.11 NFPA #90A, *Installation of Air Conditioning and Ventilating Systems* (2012 edition);
- 6.1.12 NFPA #90B, *Warm Air Heating and Air Conditioning Systems* (2012 edition); and
- 6.1.13 NFPA # 211, *Chimneys, Fireplaces, Vents, and Solid Fuel Appliances* (2013 edition).

6.2 Exceptions and Additions to Adopted Standards

6.2.1 NFPA #31, Standard for the Installation of Oil Burning Equipment (2011 edition)

The Board does not adopt the exception to Chapter 7, Section 7.12, Abandonment and Removal from Service of Tanks and Related Equipment. (See instead Chapter 8, Section 8.9.4 of the Board's rules.)

The Board does not adopt Chapter 7, Section 7.3.1, Tanks and their Supports shall Rest on Foundations made of Solid Concrete. (See instead Chapter 8, Sections 8.10 and 8.11 of the Board's rules.)

6.2.2 NFPA #52, Vehicular Gaseous Fuel Systems Code (2010 edition)

The Board does not adopt the following Chapters:

6.2.2.1 Chapter 5, General GH₂ Requirements and Equipment Qualifications;

6.2.2.2 Chapter 7, Service and Maintenance of GH₂ Engine Fuel Systems;

6.2.2.3 Chapter 9, GH₂ Compression, Gas Processing, Storage and Dispensing Systems;

6.2.2.4 Chapter 11, LNG Engine Fuel Systems; and

6.2.2.5 Chapter 14, LH₂ Fueling Facilities.

6.2.3 NFPA #54, National Fuel Gas code (2012 edition)

6.2.3.1 Installations of propane and natural gas must also comply with all other applicable statutes or rules of the State and all applicable ordinances, orders, rules, and regulations of local municipalities.

6.2.3.2 The use of unvented heaters in HUD-Code homes, as defined in 10 MRSA §9002(7)(A), is prohibited.

6.2.3.3 The Board does not adopt the exception to Chapter 10, Section 10.23.1, Prohibited Installations.

The use of unvented heaters in bedrooms and bathrooms is prohibited.

6.2.3.4 The Board does not adopt the exception to Chapter 12, Section 6.4.2.

6.2.4 NFPA #55, Compressed Gases and Cryogenic Fluids (2010 edition)

The Board does not adopt the following Chapters:

6.2.4.1 Chapter 8, Cryogenic Fluids;

6.2.4.2 Chapter 9, Bulk Oxygen Systems;

6.2.4.3 Chapter 10, Gaseous Hydrogen Systems;

6.2.4.4 Chapter 11, Liquefied Hydrogen Systems;

- 6.2.4.5 Chapter 13, Insulated Liquid Carbon Dioxide Systems; and
- 6.2.4.6 Chapter 14, Storage, Handling and Use of Ethylene Dioxide for Sterilization and Fumigation.
- 6.2.5 **NFPA #58, *Liquefied Petroleum Gas Code (2011 edition)***
- 6.2.5.1 Department of Transportation cylinders and ASME containers must rest on noncombustible materials unless listed for such purpose.
- 6.2.5.2 Bulk plant or dispensing station remotely controlled actuators on internal valves and emergency shut-off valves must not be operated with a flammable gas.
- 6.2.5.3 Any cylinder that does not have a legible manufacture date or retest date will be considered to be out of compliance and shall not be filled.
- 6.2.5.4 The Board does not adopt Chapter 6, Section 6.3.7 and adopts the following in its place:
- Cylinders and ASME containers of 125 gallons water capacity or less may be located and installed underneath a deck provided the following conditions are met:
1. The space is completely open to the atmosphere for 50 percent of its perimeter or more;
 2. There is a minimum of 2' vertical clearance between the top of the tank and any part of the structure; and
 3. The maximum aggregate water capacity of such tanks is no more than 250 gallons.
- 6.2.5.5 Portable motor fuel containers which are equipped for volumetric filling and meet the requirements of construction and inspection set forth in NFPA #58 may be filled by volume or weight.
- 6.2.5.6 Chapter 6, Section 6.4.5.5 does not apply to a single tank containing methanol, connected to and as part of a propane bulk plant, for the specific purpose of adding said methanol to the propane gas stored in the bulk plant.
- 6.2.6 **NFPA #211, *Chimneys, Fireplaces, Vents, and Solid Fuel Appliances (2013 edition)***
- 6.2.6.1 The Board does not adopt Chapter 9, Section 9.8.2 for interconnection. (See 32 MRSA §18107(1)(A))
- 6.2.6.2 The Board does not adopt Chapter 11, Fireplaces or Chapter 12, Masonry Heaters.
- 6.2.6.3 In Chapter 13, Solid Fuel-Burning Appliances, the Board does not adopt Section 13.5.2, Room Heaters, Fireplace Stoves, Room Heater/Fireplace Stove Combinations, and Ranges.

- 6.2.6.4 The Board does not adopt the following Sections of Chapter 13:
 - 6.2.6.4.1 Section 13.2, Annual Inspection, the reference to the requirements of Section 14.3;
 - 6.2.6.4.2 Section 13.4.1 of Section 13.4, Appliance or Connector Replacement, the reference to Chapter 14; and
 - 6.2.6.4.3 Section 13.7.2 of Section 13.7, Evidence of Damage.
- 6.2.6.5 The Board does not adopt Chapter 14, Inspection of Existing Chimneys.

6.3 The above NFPA standards may be purchased from:

National Fire Protection Association
1 Batterymarch Park
P.O. Box 9101
Quincy, MA 02269-9101
Telephone: 1-800-344-3555

6.4 The Board incorporates the following appendices into this Chapter:

- 6.4.1 Appendix A – Department of Environmental Protection Oil Regulations;
- 6.4.2 Appendix B – Department of Environmental Protection Asbestos Regulations;
- 6.4.3 Appendix C – Memorandum of Understanding between the Maine Fuel Board and the Plumbers’ Examining Board for the Installation of Hot Water or Steam & Warm Air Heating Systems, Radiation Supply and Return Connections;
- 6.4.4 Appendix D – Memorandum of Understanding between the Maine Fuel Board and the Electricians’ Examining Board for the Installation, Service and Repair of Hot Water, Steam, Warm Air Heating Systems and Water Heaters;
- 6.4.5 Appendix E – State of Maine Emergency Chimney Update Waiver Form;
- 6.4.6 Appendix F – Chimney or Fireplace Construction/Installation Disclosure; and
- 6.4.7 Appendix G – Vehicle Protection

[NOTE: The appendices appear at the end of the Board’s rules.]

STATUTORY AUTHORITY: 32 MRSA §18123(2)

EFFECTIVE DATE:

September 27, 3014 – filing 2014-239

02 DEPARTMENT OF PROFESSIONAL AND FINANCIAL REGULATION**658 MAINE FUEL BOARD****Chapter 7 MODIFICATION OF STANDARDS**

Summary: This Chapter allows the Board to authorize modifications to installations under unusual circumstances and provides the Board with the discretion to alter installation standards after appropriate technical consideration.

7.1 General

Where the circumstances or conditions of any particular installation are so unusual as to render the strict application of a standard imposed by the Board's rules impractical, the Board may permit such modifications as will provide a substantially equivalent degree of safety and be consistent with good engineering practice.

7.2 Procedure

Application for permission to deviate from installation standards imposed by the Board's rules must be made in writing to the Board and must document why compliance with a prescribed standard is technically impractical and how the proposed modification would provide an equivalent degree of safety. The Board may request any additional information it deems necessary to assure that the modification provides an equivalent degree of safety. Any modification allowed applies solely to the specific installation described in the application and no other.

7.3 Initial Review by Senior Fuel Inspector; Appeal to Board

The senior fuel inspector may grant the application in whole or in part or may deny the application. The senior fuel inspector's disposition of the application must be provided to the applicant in writing and must include written notice of the applicant's opportunity to appeal the disposition to the Board in writing within 30 days of the applicant's receipt of the disposition. The appeal must include an explanation of the reason for the appeal and a statement of the relief sought by the applicant. An appeal is deemed to be made on the date of its receipt by the Board. Untimely appeals will not be considered.

7.4 Appeal Hearing

An evidentiary hearing on the application will be held by the Board unless the applicant and the senior fuel inspector are able to resolve satisfactorily the matter. The appeal will be heard de novo and will be governed by the provisions of the *Maine Administrative Procedure Act* applicable to adjudicatory proceedings. The applicant has the burden of proof at hearing.

STATUTORY AUTHORITY: 32 MRSA §18123(2)

EFFECTIVE DATE:

September 27, 2014 – filing 2014-240

02 DEPARTMENT OF PROFESSIONAL AND FINANCIAL REGULATION**658 MAINE FUEL BOARD****Chapter 8 INSTALLATION OF OIL BURNING EQUIPMENT**

Summary: This Chapter sets forth requirements for the installation of oil burning equipment and describes the necessary safety controls, devices and standards for the reduction of fire hazards associated with oil-fired equipment used in residential, commercial, and industrial applications.

8.1 Nationally Accredited Testing Laboratory

All heating, chimney and fireplace equipment, as well as any accessory equipment, must be listed and approved by Underwriters' Laboratories or by an independent nationally recognized testing laboratory. Such listing must be in effect at the time of installation.

8.2 Workmanship

All work must be conducted, installed, and completed in a neat and professional manner reflecting a minimum level of competent workmanship.

8.3 Repair or Replacement

Repair of any system or replacement of parts may be made in the same manner as it was in the existing system provided that such repair or replacement is not hazardous. All material, equipment and devices must be constructed and installed in accordance with their specific purpose and listing.

8.4 Maintenance**8.4.1 General**

All oil burning equipment and systems, both new and existing, and parts thereof must be maintained in a safe condition.

8.4.2 Notification to Homeowner of Code Violations

When performing any service on a customer's heating system, the licensee must notify the homeowner of any code violations and make recommendations to address them.

8.4.3 Combustion Efficiency Test Required

When performing an annual tune-up on a heating system, a combustion efficiency test must be conducted and a copy of the test results must be posted on-site.

8.5 Installations

8.5.1 Code Compliance Required Prior to Placing into Operation

Whenever a furnace, direct-fired hot water heater, or boiler is installed, the total installation must be brought into compliance with the requirements of NFPA # 31 and all other rules of the Board **BEFORE** the furnace, direct-fired hot water heater, or boiler is fired. Prior to leaving the installation (whether installed inside or outside any structure) unsupervised, the licensed oil burner technician must observe, inspect, and test the equipment to ensure that the installation is operating safely and properly and meets all applicable rules of the Board.

8.5.2 Wiring Compliance Required Prior to Firing

Whenever a new burner is installed, the wiring must be brought into compliance with the rules of the Board before the unit is fired. The wiring update must include the following:

1. Properly rated fuse or breaker;
2. Properly rated wiring;
3. Properly installed and located emergency switch;
4. Properly installed and located thermal electric switch;
5. Properly installed and located service switch; and
6. Properly installed and located low water cut-off.

8.5.3 Combustion Efficiency Test Required

When performing an installation, a combustion efficiency test must be conducted and a copy of the test results must be posted on-site.

8.5.4 Emergency Chimney Update Waivers

When an emergency situation arises that does not allow adequate time to get the chimney lined and/or repaired before installing the new heating appliance, the licensee may defer the required repairs for up to 90 days. It is the licensee's responsibility to ensure that the installation meets all standards adopted by the Board and the manufacturer's instructions. The licensee must either install or have installed the required liner or make the proper repairs within the 90 day time period. An emergency situation may include, but is not limited to, situations of serious equipment failure, such as a cracked heat exchanger of a warm air furnace or a leaking boiler in cold weather. Emergency situations may also include failure of equipment that generates hot water and the unavailability of a chimney professional. (See Chimney Update Waiver, Appendix E to Chapter 6 of the Board's rules.)

8.5.5 Heat Loss Requirement

8.5.5.1 **New Installations.** Heat loss system design and system load calculations for all new installations must be performed prior to the installation. The

licensee must retain a copy of the heat loss system design and system load calculations such that they may be produced for inspection upon request of a Board inspector.

- 8.5.5.2 **Replacement Systems.** A heat loss and/or load calculation must be conducted before replacement of an existing system. The licensee must retain a copy of the heat loss system design or system load calculations, or the stamped plans of an engineered system, such that they may be produced for inspection upon request of a Board inspector.

8.6 Low Water Control for Oil-Fired Boilers

8.6.1 Low Water Control Required

All oil-fired boilers must be provided with a properly installed and operating low water cut-off.

8.6.2 Location

The low water cut-off may be installed in, or attached to, the boiler at the level recommended by the boiler manufacturer, but in no case shall the low water cut-off be installed below the crown sheet. The low water cut-off, when not installed directly in the boiler, may be installed either in the main supply line (vertical riser) as close to the boiler as possible, or in a water column of continuous piping attached directly to the boiler.

8.6.3 Appropriate Design

The low water cut-off must be designed and approved for the medium used (steam or water).

8.6.4 No Obstructions

No valves or other obstructive devices shall be installed between the boiler and safety controls or devices.

8.7 Piping, Pumps and Valves

8.7.1 Supply Connections/Oil Shut-off Valves

- 8.7.1.1 A listed lever or wheel thermally-operated oil shut-off valve, designed to shut off the oil supply in case of fire, must be installed at the burner and at the oil supply tank.
- 8.7.1.1.1 When outside tanks are used, a thermally operated shut-off valve must be installed where the supply line enters (inside) the building and where the oil line enters the room where the appliance is located.
- 8.7.1.1.2 When inside tanks are used and the oil supply tank is installed in a separate room, a thermally operated shut-off valve must be installed where the line enters the room where the appliance is located.

8.7.1.2 Whenever the oil supply is taken from the top of an oil tank, whether the oil tanks are outside or inside, a thermally operated wheel or lever type shut-off valve must be installed at the tank and at the burner for control of the fuel. A check valve may be used in the supply line, but no valve or obstruction shall be placed in a return line connected to a burner or pump.

8.7.2 **Thermally-Operated Valves**

Thermally operated valves over ½", that are not currently listed may be installed upon receipt of written approval of a Board inspector. The written approval must be requested and received prior to installation.

8.8 **Oil Supply and Return Piping**

8.8.1 **Continuous Supply and Return Lines Required**

Wherever a copper oil supply or return line is installed under cement, sub-floors, or earth surface, it must be continuous without any splices from the burner to the tank.

8.8.2 **Conduit Required**

All copper oil supply and return lines must be encased in a continuous piece of non-metallic liquid-tight conduit such as PVC, ENT, coated copper tubing, or other approved material and must be secured in order to prevent physical damage. The end of the conduit shall not exceed 2" from any fitting, except the connection at the fuel tank and at the fuel pump located at the burner shall not exceed 6".

In order to avoid undetected oil leaks under floors, the conduit must be a minimum of one pipe size larger than the oil supply and return lines. The ends of the conduit must penetrate the cement or earth surface a minimum of 2" above grade.

An oil supply or return line that penetrates a foundation wall must be sealed at the wall to prevent the entry of water, insects or rodents.

8.8.3 **OSV Valve or PRV Valve Required: Underground Tubing**

Coated copper tubing must have an OSV valve or PRV valve installed at the tank when used underground.

8.8.4 **OSV Valve or PRV Valve Required: Tanks Higher Than Burners**

Wherever an outlet of an oil supply tank is located more than 4' above the burner, an OSV valve or PRV valve is required.

8.8.5 **Concealment of Oil Lines**

No oil supply or return line shall be concealed in a wall, ceiling, or partition unless access to the oil supply or return line can be made without cutting through existing walls, ceilings or partitions. This may be accomplished by providing removable panels.

8.8.6 Bracket Required

When an oil filter or other accessory equipment is connected to copper piping smaller than $\frac{3}{4}$ " and is not directly connected to the oil tank or oil burner, the filter or other devices must be rigidly supported by a wall- or floor-mounted bracket or other means that provides sufficient support and stability for servicing this type of accessory equipment.

8.8.7 Flare Fittings Required

All oil supply and return lines of copper tubing must be connected by flare fittings only. All fittings must be accessible for service or replacement. No compression fittings shall be used on a supply or return oil line unless it is for the introduction of the lines at the top of the tank with a single or double tap bushing.

8.8.8 Flare Frost Fittings Required Outside

All connections of supply or return oil lines located outside must be made with flare frost fittings.

8.8.9 Disconnected Lines

No oil lines or oil devices which are disconnected from an oil supply tank, burner or unit, shall be left open. Any oil line or oil device which is disconnected or discontinued must be sealed or closed with a plug, cap or other approved fitting.

8.8.10 Removal of Unprotected Supply Lines Required

Unprotected supply lines that are buried or grouted must be removed from service.

8.8.11 Underground Piping: Tanks Over 660 Gallons

If underground or under-slab piping is connected to a tank of over 660 gallons capacity or to tanks with an aggregate capacity of over 1375 gallons, the installation of the underground piping must meet Department of Environmental Protection requirements. (See Appendix A to Chapter 6 of the Board's rules.)

8.8.12 Reporting of Oil Spills Required

Oil spills must be reported to the Department of Environmental Protection in accordance with Appendix A to Chapter 6 of the Board's rules.

8.9 Oil Supply Tanks**8.9.1 Inside Tank Fabrication**

Rectangular built-in place tanks shall be fabricated using one-quarter ($\frac{1}{4}$) inch minimum thick steel sheets reinforced on maximum 24 inch centers. Tank bottoms must be supported on 12 inch wide non-combustible piers, to a height of 8 inches above the floor. All welding must be performed by a welder. Tanks must be designed by a registered engineer who shall observe the tank under 5 PSI test and certify to it being tight under this test.

8.9.2 Manholes

- 8.9.2.1 Manholes, 16 inches in diameter or larger, must be installed in the top of all tanks of 5,000 gallons or more.
- 8.9.2.2 Manholes provided in 5,000 gallons supply tanks must be liquid tight when installed inside of a structure.
- 8.9.2.3 Manholes, when required for outside use, may take the form of a floating lifter roof or weak roof-to-shell seam, or other approved pressure relieving construction.

8.9.3 Separation from Other Appliances

All fuel oil supply tanks must be a minimum of 5' from any gas and/or solid fuel burning appliance.

8.9.4 Tank Requirements upon Conversion to an Alternative Fuel

If an oil burning appliance is converted to an alternative fuel, but the tank is left in place so that it can be returned to service at some future date, all of the following requirements must be met before the alternative fuel is used:

- 8.9.4.1 The vent piping must remain intact and open to the outside of the building;
- 8.9.4.2 The fill pipe must be removed completely and the tank must be plugged with a threaded malleable iron plug;
- 8.9.4.3 The burner supply line must be removed and the valves on both the tank and burner must be capped or plugged; and
- 8.9.4.4 If an underground oil supply line is in use and complies with Section 8.9 of this Chapter, it may remain in place provided that all of the following conditions are met:
 1. The oil line is emptied of its contents;
 2. The oil line is disconnected from the oil tank and burner; and
 3. The oil line is plugged on both ends in addition to the burner and tank fittings being plugged.

Oil can remain in the tank unless prohibited by the local Authority Having Jurisdiction or the Department of Environment Protection.

8.10 Outside Oil Supply Tanks**8.10.1 Installation on Wood Not Permitted**

Oil supply tanks shall not be installed on wood or other combustible surfaces or supports.

8.10.2 Mounting of Horizontal Oil Supply Tanks

A horizontal oil supply tank must be mounted on steel pipe legs, not exceeding 12" in height with floor flanges at the base of the steel legs and be supported by four 4" x 8" x 16" solid concrete blocks or a one piece reinforced concrete pad not smaller than the tank dimensions. The 4 blocks or the pad must rest on a firm subgrade consisting of a bed of compacted, well-draining gravel (6" minimum), crushed stone (6" minimum), or some other subgrade approved by the Board. There must be a minimum of 4" of clearance under the tank from any surface. See Figure 8-1.

8.10.3 Mounting of Vertical Oil Supply Tanks

An upright or vertical oil supply tank must be mounted on steel pipe legs not exceeding 12" in height, with floor flanges at the base of the steel leg, and must be supported by a reinforced concrete pad at least 3" thick. The pad's width and length shall not be smaller than the tank dimensions. The pad must be of one piece construction. The pad must rest on a bed of compacted, well-draining gravel (6" minimum), crushed stone (6" minimum), or some other subgrade approved by the Board. There must be a minimum of 4" of clearance under the tank from any surface. See Figure 8-2.

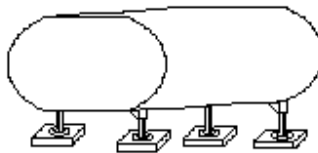

Figure 8-1 Tank footing & support for horizontal tanks of 350 gallons or less outside of buildings.

1. Footing, one (1) 4X8X16 solid cement block for each leg. Blocks to rest on a 6" bed of compacted, well draining gravel or 6" of crushed stone, or some other subgrade approved by the Board.
2. Supports, maximum 12 inch legs with floor flanges.
3. Leg brackets shall not be used for supports on blocks.
4. Bottom of tank shall have a minimum of four (4) inch clearance from any surface.

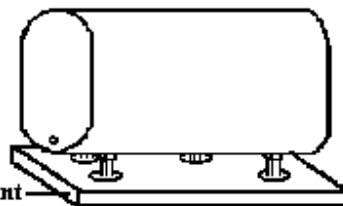

Figure 8-2 Tank footing & support for upright or vertical tanks of 350 gallons or less outside of buildings.

3" reinforced cement slab.

1. Footing, must be 3" reinforced cement slab (one piece construction) and rest on a 6" bed of compacted, well draining gravel or a 6" bed of crushed stone, or some other subgrade approved by the Board.
2. Supports, maximum 12 inch legs with floor flanges.
3. Leg brackets shall not be used for supports on blocks.
4. Bottom of tanks shall have a minimum of four (4) inch clearance from any surface.

8.10.4 Reduction of Bottom Clearance

When installing a vertical fuel oil tank in a listed secondary containment system, the 4" clearance requirement from the bottom of the tank to any surface may be reduced to a minimum of 1".

8.10.5 Leg Brackets

The leg brackets welded on the tank are not considered a leg and may not be used to rest on the side of the reinforced concrete pad or solid concrete blocks.

8.10.6 Legs Not to be Embedded in Concrete

When a reinforced concrete pad is fabricated on-site, the legs of the supply tanks shall not be embedded as part of the pad.

8.10.7 Shims Not Permitted

In all installations, the pipe flanges must be in direct contact with a reinforced concrete pad or solid concrete blocks. The use of shims is prohibited.

8.10.8 Tank Disposal

Tanks must be disposed of in accordance with the rules of the Department of Environmental Protection.

8.10.9 Prevention of Oil Spills Caused by Snow or Ice

In order to prevent oil spills, outside tanks and piping must be located such that they are not subject to falling snow or ice. To meet this requirement, the tank and outdoor piping must be installed with a protective cover over the tank valve, oil filter, and any piping which is either without structural support or not attached to the side of the building.

8.10.10 Existing Tanks to Meet Current Standards

All existing outside supply tanks must be held to the same standards as newly installed tanks.

8.10.11 Fuel Supply Line: Single Tank Installations

For a single-tank installation, the fuel supply line shall not extend more than 12 inches beyond the face of the tank.

8.11 Inside Oil Supply Tanks**8.11.1 Installation on Wood Not Permitted**

Oil supply tanks shall not be installed on wood or other combustible surfaces.

8.11.2 Support of Inside Oil Supply Tanks on Finished Floors

The tank legs of an installation of an unenclosed supply tank(s) located inside a building(s) with a finished cement floor shall not exceed 12 inches in height with floor flanges at the base of the steel legs.

8.11.3 Support of Inside Oil Supply Tanks on Unfinished Floors

The installation of an unenclosed supply tank(s) located inside a building(s) without a finished cement floor must be supported by four 4 inch x 8 inch x 16 inch solid concrete blocks or a reinforced concrete pad. The pad must be at least three 3 inches thick, the width and length extending the full dimensions of the tank. The tank legs shall not exceed 12 inches in height with floor flanges at the base of the steel legs. There must be a minimum of 4 inches of clearance under the tank from any surface. The use of shims is prohibited.

8.11.4 Multiple Tank Installation: Tops to be on Same Horizontal Plane

The top of all of the fuel oil tanks on a multiple tank installation must be on the same horizontal plane.

8.11.5 Location of Oil Shut-Off Valves

Oil shut-off valves must be provided immediately adjacent to the burner supply connections at the bottom of the supply tanks.

8.11.6 Manifold Requirements

The manifold at the cross connections of the burner supply line must be of steel, wrought-iron pipe or copper tubing. The manifold piping must be as close to the shut-off valves as possible so that the distance between the tank and the last fitting does not extend beyond 6 inches from the face of the tanks and the final fitting (elbow or tee). See Figure 8-3.

8.11.7 Prevention of Oil Spills From Multiple Tank Installations

On multiple tank installations, it is the installer's responsibility to ensure that return line product will not cause spillage.

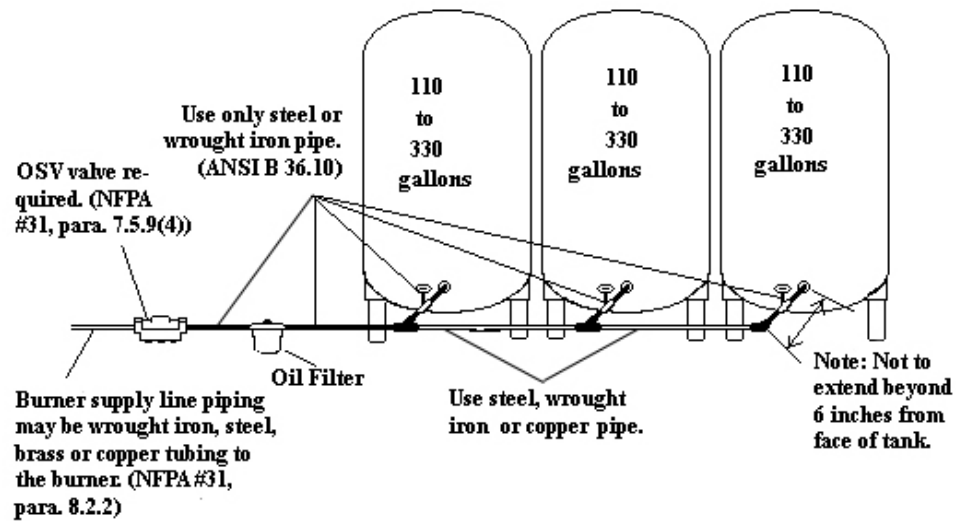

Figure 8.3 Piping for three tank oil supply arrangement

8.11.8 Multiple Tank Installations: Common Venting System

When installing multiple fuel oil tanks with separate fill pipes and a common venting system, the requirement for increasing the vent pipe one pipe size larger than the largest individual vent pipe is not applicable.

8.11.9 Cross-Connection of Two Oil Supply Tanks

When installing two tanks that are cross connected according to Figure 8.9.1 of NFPA #31 (2011 edition), the gauge must be installed only in the vented tank and all burner supply piping from the tank outlet to the filter installed at the tank must be black iron pipe. The piping connected from the second tank may be either black iron pipe or copper tubing. If the filter is not located at the tank manifold, then copper tubing may be used to connect the black iron pipe manifold to the inlet of the filter.

8.11.10 Removal of Piping Required Upon Removing Tank From Service

When removing, replacing, or taking a tank out of service for any period of time, the oil tank fill and vent piping must be removed from the side of the building.

8.12 Vent Alarms

8.12.1 Inside Tanks

All No. 1 and No. 2 fuel oil tanks from 11 to 5,000 gallon capacity located inside a structure must have a vent alarm.

8.12.2 Outside Tanks

All No. 1 and No. 2 fuel oil tanks from 65 to 5,000 gallon capacity located outside must have a vent alarm.

8.12.3 Manufacturer's Instructions

All vent alarms must be installed according to manufacturer's Instructions.

8.13 Tank Patches

All oil supply tanks must be liquid tight. Leaking tanks may be temporarily repaired with a tank patch. Any tank so repaired must be replaced within 30 days of the repair.

8.14 Used Underground Oil Tanks

Used underground oil storage tanks are prohibited from use for aboveground storage of oil unless:

1. Such use has been approved by the Maine State Fire Marshal; or
2. A Maine licensed professional engineer, or other person meeting the requirements of the statutes and rules governing professional engineers practicing in Maine, certifies that the tank meets all applicable specifications and requirements of UL #142 as referenced in NFPA #31, Chapter 7, Section 7.2.7.1(4) (2011 edition).

8.15 State Internal Plumbing Rules

All piping and safety controls on domestic water heaters and domestic water connections to boilers and heaters must be made in accordance with the *International Association of Plumbing and Mechanical Officials Uniform Plumbing Code*, 2009 edition, as adopted in Chapter 4 of the rules of the Plumbers' Examining Board.

8.16 Electrical Equipment, Required Control Switches

8.16.1 Thermal Cut-Off Switches

A thermal cut-off switch must be wired into the burner circuit to shut off the burner in the event of a fire at the unit. The switch must be placed at the highest point directly above the unit to be fired with the thermal element pointed downwards and must be placed on the bottom of the floor joist or stringer at the front of the unit. In no case shall it be lower than the point where the flue connector enters the chimney. The switch must be wired to shut off the burner, circulating fan, forced or induced draft fan and any remote oil pump that is not an integral part of the burner. A thermal electric switch is required for each oil-fired unit in a multi-appliance installation.

8.16.1.1 On multi-unit installations, the emergency and thermal electrical switches must be wired in series through individual unit relays so that, if one switch is opened, all equipment will be rendered inoperable whenever the "EMERGENCY" switch is opened.

8.16.1.2 All remote pump sets must have a thermal cut-out switch installed as follows:

1. Maximum of 3 feet above pump set;
2. The element must be pointed downwards; and
3. The switch must be supported in accordance with NFPA #70 (2011 edition).

8.16.2 Service Switch

A service disconnect switch for control of the burner while observing the flame must be placed at the unit, within arm's reach of the technician.

8.16.3 Emergency Switch

8.16.3.1 If the entrance to the boiler room is only accessible from the outside, the emergency switch may be placed at the inside not more than one foot beyond the door opening. An emergency switch shall not be placed outside of any building.

8.16.3.2 On commercial and industrial equipment, the emergency switch must be installed in accordance with Figure 8-4 on multi-unit installations. The requirements of Section 8.16.1.1 do not apply to one- or two-family residences.

8.16.3.2.1 On multi-unit installations, the emergency shut-off switch must be placed at the outside entrance of the room containing the appliances. The emergency switches and the thermal cut-off switches must be wired in series through individual unit relays so that, if the emergency switch is opened, all heating equipment in the room and the remote pump set will be rendered inoperable. This application also applies if there are two or more appliance rooms in the same building that are connected to a common fuel supply system.

[NOTE: For Primary Safety Controls, Required Programming and Timings for Burners, refer to ASME CSD-1.]

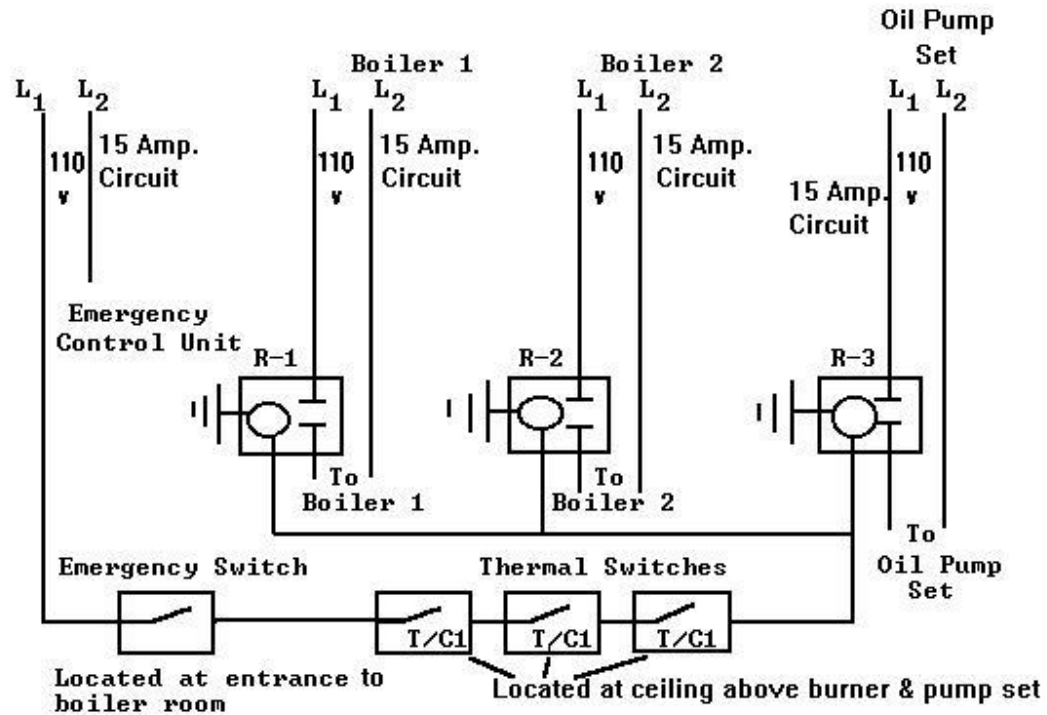

Figure 8-4 For use on commercial and industrial equipment only.
This requirement shall not apply to one and two family residences.

8.16.4 Controls Containing Mercury

Thermostats containing mercury must be disposed of in accordance with all federal and State Regulations. (Refer to 38 MRSA §1663 and check with your local supplier)

8.17 Use of Priority Controls

A priority control for installation of an oil-fired warm air furnace and an oil-fired hot water heater when the existing chimney flue is not of adequate size to accommodate both appliances is allowed. The chimney must be lined. A priority control is required when replacing an existing furnace or water heater when the chimney is not properly sized for both appliances.

8.18 Steam Boilers

Steam boilers must be installed according to manufacturer's instructions.

8.19 Safety and Pressure Relief Valves

8.19.1 Approved Safety or Pressure Relief Valve Required

Steam and hot water boilers must be equipped with listed or approved steam safety or pressure relief valves that conform to ASME requirements. A shut-off valve shall not be placed between the relief valve and the boiler or on discharge pipes between such valves and the atmosphere.

8.19.2 Termination

All steam safety or pressure relief valves must terminate in a manner which precludes the possibility of accidental scalding in accordance with ASME.

8.19.3 Location

Steam safety or pressure relief valves which terminate in the structure must terminate 6" to 12" above the floor.

8.19.4 Installation in Upright Vertical Position Required

Steam safety and pressure relief valves on boilers must be installed with the spindle in the upright vertical position.

8.20 Water and Steam Boiler Pipe Supports**8.20.1 General**

Piping must be supported with pipe hooks, metal pipe straps, bands, brackets, or hangers suitable for the size of the piping and must be of adequate strength and quality and located at intervals so as to prevent or damp out excessive vibration.

8.20.2 Spacing

Spacing of supports shall not be greater than shown in Table 8-1.

8.20.3 Allowance for Expansion and Contraction

Supports, hangers, and anchors must be installed so as not to interfere with the free expansion and contraction of the piping between anchors. All parts of the supporting equipment must be designed and installed so that they will not be disengaged by movement of the supporting piping.

**Table 8-1
Support of Piping**

| Steel Pipe, Nominal Size of Pipe (Inches) | Spacing of Supports (Feet) | Nominal Size of Tubing (Inch O.D.) | Spacing of Supports (Feet) |
|--|---|---|---|
| 1/2 | 6 | 1/2 | 4 |
| 3/4 or 1 | 8 | 5/8 or 3/4 | 6 |
| 1 1/4 or larger (horizontal) | 10 | 7/8 or 1 | 8 |
| 1 1/4 or larger (vertical) | every floor level | | |

8.21 Emergency Temporary Repairs of Warm Air Heat Exchangers

Emergency temporary repairs of warm air heat exchangers in oil burning appliances are allowed if the safety limitations of the repairs are explained in writing to the owner at the time of the repair.

8.22 Welding of Non-Residential Warm Air Heat Exchangers

8.22.1 General

Welding of non-residential warm air heat exchangers is permissible only as set forth in this Section. Welding of residential warm air heat exchangers is not permissible under any circumstances.

8.22.2 Consultation With Manufacturer Required

The manufacturer must be consulted to determine whether the welding of a heat exchanger is sound engineering practice. The manufacturer must provide a written statement as to the feasibility of its heat exchanger being welded. If the heat exchanger is no longer in production, a master licensee must make a written request to the Board and obtain written approval from the Board before the repair is undertaken.

8.22.3 Master Licensee to Oversee Welding Repair

The repair of a heat exchanger by welding must be performed by a welder in a procedure suitable for the material. A master licensee must oversee such repairs. The master licensee must receive guidance from the welder as to the feasibility and acceptability of performing the welding procedure of the metals prior to the repair of any heat exchanger. After completion of said repairs or welding, the master licensee must obtain a written statement from the welder documenting that the heat exchanger has been welded, tested and is acceptable for use without leakage of flue gases.

8.22.4 Documentation of Repair to be Provided to Owner

Written documentation of said repairs or welding must be provided to the owner. The original documentation must be kept on file by the master licensee who requested the welding. A copy of all the repair documents containing, at a minimum, the following information must be sent to the Board:

1. The name of the owner and location where the repairs were completed;
2. The name and address of the welder;
3. Specific area(s) or location(s) where the repair(s) or welding was performed;
4. Written approval of the repair from the manufacturer where applicable;
5. Equipment identification information, i.e., name, model number, serial number and gross Btu. rating; and
6. The name, address, and license number of the master licensee who requested the repair.

8.22.5 **Limitation**

Welding repair of a heat exchanger may be performed only once. A subsequent welding repair shall not be made to a heat exchanger unless a master licensee makes written request to the Board and obtains written approval from the Board before the repair is undertaken.

STATUTORY AUTHORITY: 32 MRSA §18123(2)

EFFECTIVE DATE:

September 27, 2014 – filing 2014-241

02 DEPARTMENT OF PROFESSIONAL AND FINANCIAL REGULATION**658 MAINE FUEL BOARD****Chapter 9 INSTALLATION OF SOLID FUEL BURNING EQUIPMENT**

Summary: This Chapter sets forth requirements for the proper installation of solid fuel burning equipment.

9.1 Scope

This Chapter applies to residential, commercial and industrial installations of solid fuel burning equipment which are connected to a central heating system or water heating equipment.

9.2 Nationally Accredited Testing Laboratory

All heating, chimney and fireplace equipment, as well as any accessory equipment, must be listed and approved by Underwriters' Laboratories or by an independent nationally recognized testing laboratory. Such listing must be in effect at time of installation.

9.3 Workmanship

All work must be conducted, installed, and completed in a neat and professional manner reflecting a minimum level of competent workmanship.

9.4 Installations

Whenever a furnace, direct-fired water heater, or boiler is installed, the total installation must be brought into compliance with the requirements of NFPA #211 (2013 edition) and all other rules adopted by the Board **BEFORE** the furnace, direct-fired water heater, or boiler is fired. Prior to leaving the installation (whether installed inside or outside any structure) unsupervised, the licensed solid fuel technician must observe, inspect, and test the equipment to ensure that the installation is operating safely in accordance with the Board's rules.

9.5 Repair or Replacement

Repair of any system or replacement of parts may be made in the same manner as it was in the existing system provided that such repair or replacement is not hazardous. All material, equipment and devices must be constructed and installed in accordance with their specific purposes and listings.

9.6 Notification to Homeowner of Code Violations

When performing any service on a customer's heating system, the licensee must notify the owner of any code violations and make recommendations to address them.

9.7 Heat Loss Requirement

9.7.1 New Installations

Heat loss system design and system load calculations for all new installations must be performed prior to the installation. The licensee must retain a copy of the heat loss system design and system load calculations such that it may be produced for inspection upon request of a Board inspector.

9.7.2 Replacement Systems

A heat loss and/or load calculation must be conducted before replacement. The heat loss and/or load calculation may be obtained from the original design plans. The licensee must retain a copy of the heat loss system design or system load calculations and produce it for inspection upon request of a Board inspector.

9.8 Appliances

9.8.1 Installation to Conform to Listing

Solid fuel burning appliances must be listed and installed in accordance with the terms of their listing.

9.8.2 Manufacturer's Instructions

The manufacturer's instructions must be left with the owner.

9.8.3 Installation to be Made by Experienced Technicians

The installation must be made by licensed technicians experienced in making such installations.

9.8.4 Accessibility for Cleaning, Repair and Maintenance

The installation must be such as to provide reasonable accessibility for: cleaning heating surfaces; removing burners (multi-fuel and/or combination units); replacing motors, controls, air filters, draft regulators, chimney connectors, and other working parts; and adjusting, cleaning, and lubricating parts requiring such attention. This requirement also pertains to stoker-fired units.

9.8.5 Clearance From Combustible Materials

No combustible material shall be placed adjacent to the solid fuel burning appliance with less clearance than permitted by the manufacturer, NFPA #211 (2013 edition) or the Board's rules.

9.8.6 Flammable Vapors or Gases

Solid fuel burning units shall not be installed where gasoline or any other flammable vapors or gases are likely to be present unless the unit is a sealed combustion system for which the air is taken from the outside.

9.8.7 Installations in Conjunction With Oil Burning Equipment

Whenever a solid fuel appliance is installed to work in conjunction with an oil burning appliance, the wiring of the oil burning appliance must be brought into compliance with the requirements of the Board's rules before the unit is fired. The wiring update must include the following where applicable:

1. Properly rated fuse or breaker;
2. Properly rated wiring;
3. Properly installed and located emergency switch;
4. Properly installed and located thermal electric switch;
5. Properly installed and located service switch; and
6. Properly installed and located low water cut-off.

9.9 Solid Fuel in Garages

Except as described below, solid fuel burning appliances shall not be installed in any garage unless installed in a separate room, either in or attached to the garage, that is accessible only from the outside. For a major repair garage, the required fire wall separation is 2 hours. For a minor repair or parking garage, the required fire wall separation is one hour. All combustion air must be taken from outside the building.

Exception: Solid fuel burning appliances using sealed combustion systems for which the air for combustion is taken from the outside may be installed in garages of one- and two-family dwellings.

9.10 Power Failure By-Pass and Valves

9.10.1 Power Failure By-Pass and Valve Required

A boiler must be provided with a power failure by-pass and valve in a closed system.

9.10.2 Installation of By-Pass Valves

To prevent overheating conditions during a power failure, a normally open zone valve must be connected to the largest heating loop in the system above the level of the boiler. A manual by-pass valve must be installed in case of the failure of the zone valve. This shall be accomplished by installing the zone valve prior to the flow valve and connecting it to the largest loop in the system. The hand valve must be installed in a loop around the zone valve as illustrated in Figure 9-1.

9.10.3 By-Pass Valves – Outside Boilers

Section 9.10.2 does not apply to listed outdoor solid fuel burning central heating appliances.

9.10.4 Limitation of Applicability

Section 9.10.2 does not apply to solid fuel burning appliances for which the interruption of power will arrest combustion and interrupt fuel supply if the appliance is a residential-type heating appliance as defined in NFPA #211 (2013 edition).

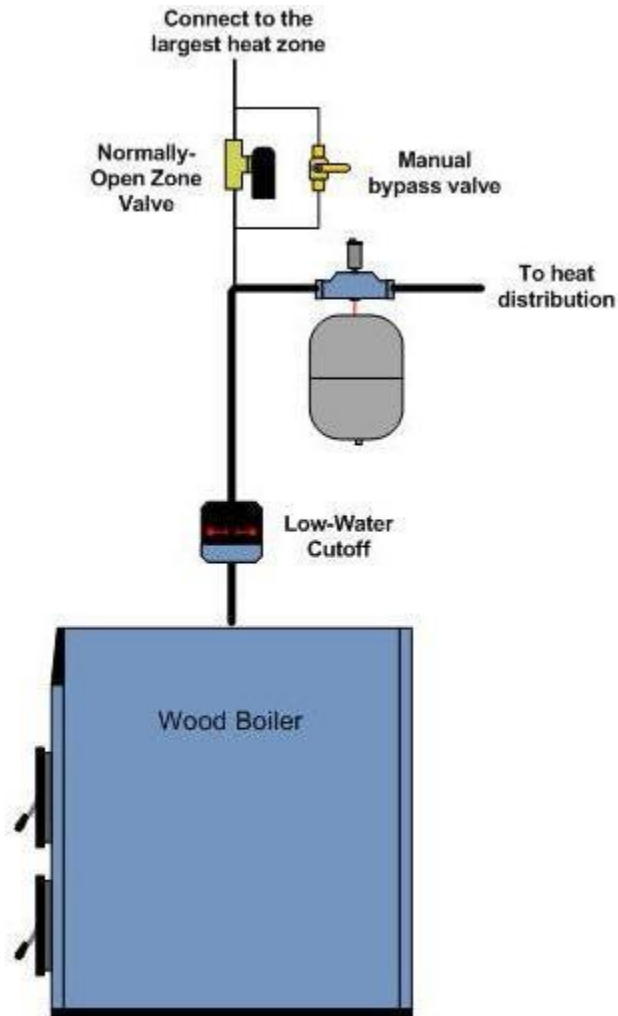

Figure 9-1
Power Failure By-Pass

9.11 Air Combustion and Ventilation

Solid fuel burning appliances must be installed in a location and manner to provide adequate ventilation and combustion air supply to permit proper fuel combustion, chimney draft and maintenance of safe temperatures. In cases of buildings which are so tight that normal infiltration does not provide the necessary air, outside air must be introduced in accordance with manufacturer's instructions.

9.12 Electrical Wiring and Equipment

9.12.1 Basic Standards

The following standards must be met for the electrical wiring and equipment used in connection with solid fuel burning equipment:

- 9.12.1.1 The electrical wiring and equipment used must be installed in accordance with NFPA #70, *National Electrical Code* (2011 edition).
- 9.12.1.2 Safety control circuits must be two-wire, one side grounded, having a nominal voltage not exceeding 150 Volts. A safety control or protective device must be connected so as to interrupt the ungrounded conductor; and
- 9.12.1.3 The control circuit must be connected to a power supply branch circuit fused at not more than the value appropriate for the rating of any control or device included in the circuit.

9.12.2 Additional Standards: Automatic Feed

The following additional standards must be met for solid fuel burning appliances where the fuel is automatically fed:

9.12.2.1 Electrical Equipment, Required Control Switches

- 9.12.2.1.1 **Thermal Electric Switches.** A thermal cut-off switch must be wired into the burner circuit to shut off the burner in the event of a fire at the unit. The switch must be placed directly above the unit to be fired with the thermal element pointed downwards and must be placed at the front of the unit. The switch must be no lower than the highest point of the flue connector where it enters the chimney. The switch must be wired to shut-off the burner, circulating fan, forced or induced draft fan and any remote fuel delivery device that is not an integral part of the burner. A thermal electric switch is required for each unit in a multi-appliance installation.
- 9.12.2.1.2 On multi-appliance installations the emergency and thermal electrical switches must be wired in series through individual unit relays such that, if one thermal switch or the “EMERGENCY” switch is open, the combustion air fan and fuel delivery system will be shut off. This also applies if there are two or more appliance rooms in the same building connected to a common fuel supply system.

[NOTE: An example of wiring for multi-appliance installations is illustrated in Figure 9-2.]

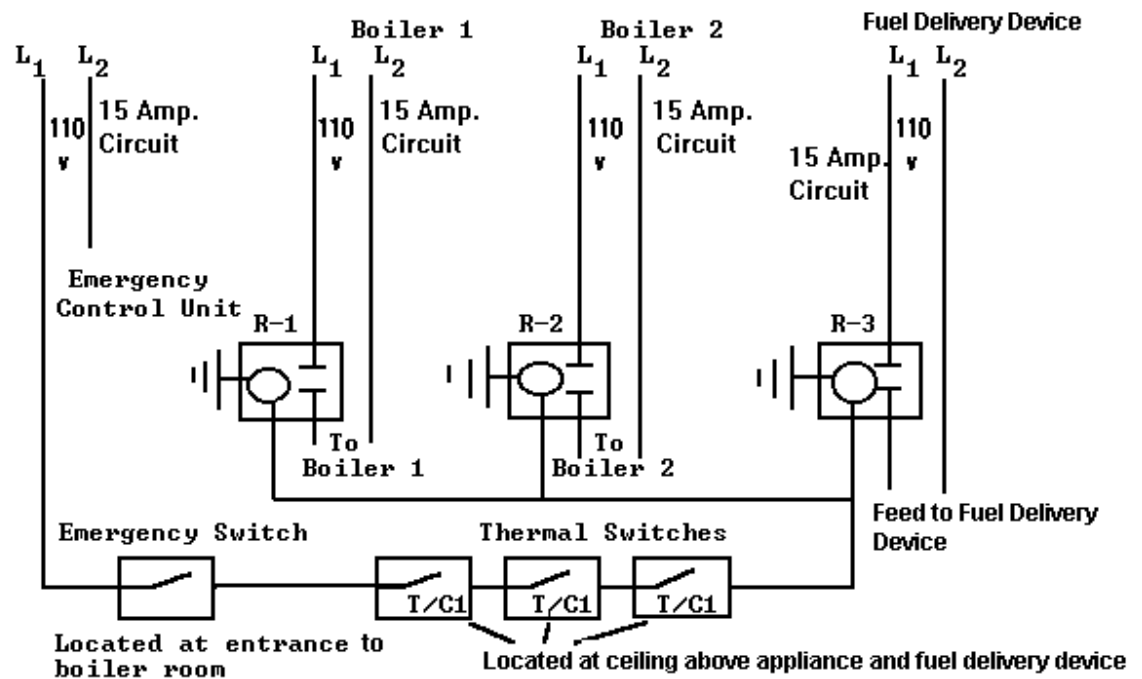

Figure 9-2

9.12.2.2 **Disconnect Switch.** A burner disconnect switch must be placed within 3 feet of the burner.

9.12.2.3 **Emergency Switch**

9.12.2.3.1 An identified switch to shut down the boiler, furnace or water heater in an emergency must be placed outside of and adjacent to the entrance to the room where the appliance is located.

9.12.2.3.2 If the entrance to the room where the appliance is located is only accessible from outdoors, the emergency switch may be placed inside not more than one foot beyond the door opening.

9.13 Installation of Combination Units (Solid Fuel/Oil/Gas)

All multi-fueled appliances must comply with the applicable provisions of the Board's rules.

9.14 Conversion Burners

When an appliance is converted from a liquid or gaseous fuel to a solid fuel, the conversion burner must be listed by Underwriters' Laboratory or by an independent nationally recognized testing laboratory and must comply with all Sections of this Chapter.

9.14.1 Testing in Individual Appliance Required

A conversion burner must be tested for use in the individual appliance in which it is intended to be installed and must meet one of the following conditions:

1. The conversion burner has been tested by the burner manufacturer in the individual appliance in which it is intended to be installed and has been approved for use in such appliance by a licensed professional engineer with the proper disciplines;
2. The conversion burner has been tested by an independent testing laboratory in the individual appliance in which it is intended to be installed and has been certified for use in such appliance by the independent testing laboratory; or
3. The conversion burner has been tested by the appliance manufacturer in the individual appliance in which it is intended to be installed and has been approved for use in such appliance by the appliance manufacturer.

Such appliance manufacturer or licensed professional engineer must provide installation and combustion set-up instructions for the appliance.

9.14.2 **Installation into Direct Vent Appliances**

A conversion burner shall not be installed into direct vent appliances unless the conversion burner has been approved for use in the appliance by the manufacturer of the appliance.

9.14.3 **Installation into Power Vented Appliances**

A conversion burner shall not be installed into power vented appliances unless the power venter is specifically approved for use with solid fuel.

9.14.4 **Conversion From Another Fuel Source**

When converting to solid fuel from another fuel source, the installation must comply with all applicable provisions of NFPA #211 (2013 edition) and the Board's Rules.

9.14.5 **Clearance From Combustible Materials Required**

Warm air furnace plenums and ductwork must comply with the applicable provisions of NFPA #90B (2012 edition) for clearance from combustible materials.

9.14.6 **Temporary Removal of Oil Tank From Service**

When an oil tank is temporarily taken out of service for the purpose of using a solid fuel conversion burner, the following must be done:

1. The fill pipe to the tank must be completely removed and the fitting in the tank plugged liquid tight with a threaded plug;
2. The oil line to the boiler or furnace must be capped or plugged at both ends and the thermal valve must be capped or plugged at the tank; and
3. All vent lines must remain intact to the outside and remain open.

9.14.7 Interlock Device Required

An interlock device must be installed so that combustion will be arrested if the burner is removed from the heating appliance.

9.14.8 Limited Control Required

Furnaces must have a 250 degree Fahrenheit limit control installed in the supply plenum not more than 10" above the top surface of the heat exchanger. The limit control shall extend at least 12" into the supply plenum.

9.15 Water Heaters

All piping and safety controls on potable water heaters and potable water connections to boilers and tankless coil heaters must comply with applicable provisions of the State of Maine Plumbers' Examining Board Laws and Rules.

9.16 Low Water Control For Solid Fuel Fired Boilers

Low water protection shall be accomplished in one of two ways:

9.16.1 When Electrical Circuit Arrests Combustion

If the opening of an electric circuit will arrest the combustion process, a low water cut-off will be satisfactory if it conforms to the following:

1. All solid fuel fired boilers must be provided with a properly installed and operating low water cut-off. The low water cut-off may be installed in, or attached to, the boiler at the level recommended by the boiler manufacturer, but in no case shall the low water cut-off be installed below the crown sheet. The low water cut-off, when not installed directly in the boiler, may be installed either in the main supply line (vertical riser) as close to the boiler as possible or in a water column of continuous piping attached directly to the boiler;
2. The low water cut-off must be designed and approved for the media in which it is used, either steam or water; or
3. No valves or other obstructive devices shall be installed between the boiler and any safety controls or devices.

9.16.2 When Electrical Circuit Does Not Arrest Combustion

If the opening of an electric circuit will not arrest the combustion process, low water protection must be accomplished in accordance with the appliance manufacturer's instructions.

9.17 Safety and Pressure Relief Valves**9.17.1 Approved Safety or Pressure Relief Valve Required**

Steam and hot water boilers must be equipped with listed or approved steam safety or pressure relief valves that conform to ASME requirements. A shut-off valve shall not

be placed between the relief valve and the boiler or on discharge pipes between such valves and the atmosphere.

9.17.2 Termination

All steam safety or pressure relief valves must terminate in a manner which precludes the possibility of accidental scalding.

9.17.3 Location

Steam safety or pressure relief valves which terminate in the structure must terminate 6" to 12" above the floor.

9.17.4 Installation in Upright Vertical Position Required

Steam safety and pressure relief valves on boilers must be installed with the spindle in the upright vertical position.

9.18 Water and Steam Boiler Pipe Supports

9.18.1 Generally

Piping must be supported with pipe hooks, metal pipe straps, bands, brackets, or hangers suitable for the size of the piping and must be of adequate strength and quality and located at appropriate intervals so as to prevent or damp out excessive vibration.

9.18.2 Spacing

Spacing of supports shall not be greater than shown in Table 9-1.

9.18.3 Allowance for Expansion and Contraction

Supports, hangers, and anchors must be installed so as to not interfere with the free expansion and contraction of the piping between anchors. All parts of the supporting equipment must be designed and installed so that they will not disengage by movement of the supporting piping.

**Table 9-1
Support of Piping**

| Steel Pipe, Nominal Size of Pipe (Inches) | Spacing of Supports (Feet) | Nominal Size of Tubing (Inch O.D.) | Spacing of Supports (Feet) |
|--|---|---|---|
| 1/2 | 6 | 1/2 | 4 |
| 3/4 or 1 | 8 | 5/8 or 3/4 | 6 |
| 1 1/4 or larger (horizontal) | 10 | 7/8 or 1 | 8 |
| 1 1/4 or larger (vertical) | every floor level | | |

9.19 Thermostatically-Controlled, Hand-Fired Warm Air Units

9.19.1 Limit Control Required

A 250 degree Fahrenheit limit control must be installed in the supply plenum not more than 10" above the top surface of the heat exchanger and must extend at least 12" into the supply plenum.

9.19.2 Operation of Limit Control

The limit control must automatically prevent operation of the furnace in the event of power failure or shut off when 250 degrees Fahrenheit temperature is reached whether or not the electrical power source is available.

9.19.3 Barometric Draft Control

A barometric draft control, if required, must be installed in accordance with the manufacturer's instructions.

9.20 Emergency Temporary Repair of Warm Air Heat Exchangers

Emergency temporary repairs of warm air heat exchangers in solid fuel burning appliances are allowed if the safety limitations of the repairs are explained in writing to the owner at the time of the repair.

9.21 Welding of Non-Residential Warm Air Heat Exchangers

9.21.1 General

Welding of non-residential warm air heat exchangers is permissible only as set forth in this Section. Welding of residential warm air heat exchangers is not permissible under any circumstances.

9.21.2 Consultation With Manufacturer Required

The manufacturer must be consulted to determine whether the welding of a heat exchanger is sound engineering practice. The manufacturer shall provide a written statement as to the feasibility of its heat exchanger being welded. If the heat exchanger is no longer in production, a master licensee shall make a written request to the Board and obtain written approval from the Board before the repair is undertaken.

9.21.3 Master Licensee to Oversee Welding Repair

The repair of a heat exchanger by welding must be performed by a welder in a procedure suitable for the material. A master licensee shall oversee such repairs. The master licensee shall receive guidance from the welder as to the feasibility and acceptability of performing the welding procedure of the metals prior to the repair of any heat exchanger. After completion of said repairs or welding, the master licensee shall obtain a written statement from the welder documenting that the heat exchanger has been welded, tested and is acceptable for use without leakage of after-products.

9.21.4 Documentation of Repair to be Provided to Owner

Written documentation of said repairs or welding must be provided to the owner. The original documentation must be kept on file by the master licensee who requested the welding. A copy of all the repair documents containing, at a minimum, the following information must be sent to the Board:

1. The name of the owner and location where the repairs were completed;
2. The name and address of the welder;
3. Specific area(s) or location(s) where the repair(s) or welding was performed;
4. Written approval of the repair from the manufacturer where applicable;
5. Equipment identification information, i.e., name, model number, serial number and gross Btu. rating; and
6. The name, address, and license number of the master licensee who requested the repair.

9.21.5 Limitation

Welding repair of a heat exchanger may be performed only once. A subsequent welding repair shall not be made to a heat exchanger unless a master licensee makes written request to the Board and obtains written approval from the Board before the repair is undertaken.

STATUTORY AUTHORITY: 32 MRSA §18123(2)

EFFECTIVE DATE:

September 27, 2014 – filing 2014-242

02 DEPARTMENT OF PROFESSIONAL AND FINANCIAL REGULATION**658 MAINE FUEL BOARD****Chapter 10 CHIMNEYS**

Summary: This Chapter governs the removal of waste gases and the reduction of fire hazards associated with the construction and installation of chimneys, fireplaces, and venting systems for residential, commercial, and industrial applications.

10.1 Nationally-Accredited Testing Laboratory

All heating, chimney and fireplace equipment, as well as any accessory equipment, must be listed and approved by Underwriters' Laboratories or by an independent nationally recognized testing laboratory. Such listing must be in effect at time of installation.

10.2 Chimney Disclosure

All masonry chimney systems must be constructed in accordance with NFPA #211, Chapter 7 (2013 edition) as incorporated by reference into Chapter 6 of the Board's rules. An installer must complete the State of Maine Chimney Disclosure Form attached as Appendix F to Chapter 6 of the Board's rules prior to connecting an appliance to a newly-constructed masonry chimney.

10.3 Use of Existing Chimneys

The required 2" minimum clearance to combustible material for existing interior chimneys and the required 1" minimum clearance to combustible material for existing exterior chimneys is not required when replacing oil- or gas-fired appliances.

[NOTE: The above clearances are required when a solid fuel appliance or a wood stove is connected to the chimney flue.]

10.4 Interconnection**10.4.1 Gas and Liquid Fuel Appliances**

Gas utilization appliances and appliances burning liquid fuels may be connected to one chimney in accordance with NFPA 211, Chapter 9, Section 9.8 (2013 edition).

10.4.2 Oil and Solid Fuel-Burning Equipment

The interconnection of oil and solid fuel-burning equipment must meet the requirements of 32 MRSA §18107.

STATUTORY AUTHORITY: 32 MRSA §18123(2)

EFFECTIVE DATE:

September 27, 2014 – filing 2014-243

02 DEPARTMENT OF PROFESSIONAL AND FINANCIAL REGULATION**658 MAINE FUEL BOARD****Chapter 11 INSTALLATION OF WASTE OIL APPLIANCES AND WASTE OIL SUPPLY TANKS**

Summary: This Chapter sets forth requirements for the use of waste (used) oil burning equipment and accessory equipment installations in specific applications.

11.1 Nationally-Accredited Testing Laboratory

All heating, chimney and fireplace equipment, as well as any accessory equipment, must be listed and approved by Underwriters' Laboratories or by an independent nationally recognized testing laboratory. Such listing must be in effect at time of installation.

11.2 Workmanship

All work must be conducted, installed and completed in a neat and professional manner reflecting a minimum level of competent workmanship.

11.3 General**11.3.1 Required License Authorities**

The installation and service of waste oil appliances is covered as a function granted under the 1&2 Up and the 1&2 Over oil burner license authorities.

11.3.2 Experience Required

The installation of waste oil burning unit(s) and their service must be performed by licensed individuals experienced in servicing and installing such equipment.

11.3.3 Manufacturer's Instructions

The installation and servicing of waste oil appliances must be made in accordance with the manufacturer's instructions and State and local codes.

11.3.4 Labeling of Waste Oil Tanks

Waste oil tanks must be labeled with the words "Used Oil" in accordance with 40 CFR §279.22(c)(1-2).

11.4 Repair or Replacement

Repair of any system or replacement of parts may be made in the same manner as it was in the existing system provided that such repair or replacement is not hazardous. All material, equipment and devices must be constructed and installed in accordance with their specific purposes and listings.

11.5 Maintenance

11.5.1 General

All oil burning equipment and systems, both new and existing, and parts thereof must be maintained in a safe condition.

11.5.2 Notification to Owner of Code Violations

When performing any service on a customer's heating system, the licensee must notify the owner of any code violations and make recommendations to address them.

11.5.3 Combustion Efficiency Test Required

When performing an annual tune-up on a heating system, a combustion efficiency test must be conducted and a copy of the test must be posted on-site.

11.6 Installations

11.6.1 Code Compliance Required Prior to Firing

Whenever a furnace, direct-fired hot water heater, or boiler is installed, the total installation must be brought into compliance with the requirements of NFPA # 31 (2011 edition) and all other rules of the Board **BEFORE** the furnace, direct-fired hot water heater, or boiler is fired. Prior to leaving the installation (whether installed inside or outside any structure) unsupervised, the licensed oil burner technician must observe, inspect, and test the equipment to ensure that the installation is operating safely and properly and meets all applicable rules of the Board.

11.6.2 Wiring Compliance Required Prior to Firing

Whenever a new burner is installed, the wiring must be brought into compliance with the requirements of Board's rules before the unit is fired. The wiring update must include the following:

1. Properly rated fuse or breaker;
2. Properly rated wiring;
3. Properly installed and located emergency switch;
4. Properly installed and located thermal electric switch;
5. Properly installed and located service switch; and
6. Properly installed and located low water cut-off.

11.6.3 Combustion Efficiency Test Required

When performing an installation, a combustion efficiency test must be conducted and a copy of the test results must be posted on-site.

11.7 Low Water Control for Used Oil Fired Boilers

11.7.1 Low-Water Control Required

All used oil-fired boilers must be provided with a properly installed and operating low-water cut-off.

11.7.2 Location

The low water cut-off may be installed in, or attached to, the boiler at the level recommended by the boiler manufacturer, but in no case shall the low water cut-off be installed below the crown sheet. The low water cut-off, when not installed directly in the boiler, may be installed either in the main supply line (vertical riser) as close to the boiler as possible, or in a water column of continuous piping attached directly to the boiler.

11.7.3 Appropriate Design

The low water cut-off must be designed and approved for the medium used (steam or water).

11.7.4 No Obstructions

No valves or other obstructive devices shall be installed between the boiler and safety controls or devices.

11.8 Piping, Pumps and Valves

11.8.1 Supply Connections

11.8.1.1 A listed lever or wheel, thermally-operated oil shut-off valve designed to shut off the oil supply in case of fire, must be installed at the burner and at the oil supply tank.

11.8.1.1.1 When outside tanks are used, a thermally operated shut-off valve must be installed where the supply line enters (inside) the building.

11.8.1.1.2 When inside tanks are used and the oil supply tank is installed in a separate room, a thermally operated shut-off valve shall be installed where the line enters the room where the appliance is located.

11.8.1.2 Whenever the oil supply is taken from the top of an oil tank, whether the oil tanks are outside or inside, a thermally operated wheel or lever type shut-off valve must be installed at the tank and at the burner for control of the fuel. A check valve may be used in the supply line, but no valve or obstruction shall be placed in a return line connected to a burner or pump.

11.8.2 Thermally-Operated Valves

Thermally operated valves over ½" that are not currently listed may be installed upon receipt of written approval of a Board inspector. The written approval must be requested and received prior to installation.

11.9 Oil Supply and Return Piping

11.9.1 Underground Supply and Return Lines

Whenever a copper oil supply or return line is installed under cement, sub-floors, or earth surface, it must be continuous from the burner to the tank without any splices.

11.9.2 Conduit Required

All copper oil supply and return lines must be encased in a continuous piece of non-metallic liquid-tight conduit such as PVC, ENT, coated copper tubing, or other approved material and must be secured in order to prevent physical damage. The end of the conduit shall not exceed more than 2 inches from any fitting, except the connection at the fuel tank and at the fuel pump located at the burner shall not exceed 6 inches.

In order to avoid undetected oil leaks under floors, the conduit must be a minimum of one pipe size larger than the oil supply and return lines. The ends of the conduit must penetrate the cement or earth surface a minimum of 2 inches above grade.

An oil supply or return line that penetrates a foundation wall must be sealed at the wall to prevent the entry of water, insects or rodents.

11.9.3 OSV Valve or PRV Valve Required: Tanks Higher Than Burner

Coated copper tubing must have an OSV valve or PRV valve installed at the tank when used underground.

11.9.4 OSV Valve or PRV Valve Required: Outlets

Wherever an outlet of an oil supply tank is located more than 4 feet above the burner, an OSV valve or PRV valve is required.

11.9.5 Non-Concealment of Oil Lines

No oil supply or return line shall be concealed in a wall, ceiling, or partition unless access to the oil supply or return line can be had without cutting through existing walls, ceilings or partitions. This may be accomplished by providing removable panels.

11.9.6 Bracket Required

When an oil filter or other accessory equipment is connected to copper piping smaller than $\frac{3}{4}$ inches and is not located within the vicinity of the oil supply or burner connections, the filter or other devices must be rigidly supported by a wall- or floor-mounted bracket or other means that provides sufficient support and stability for servicing this type of accessory equipment.

11.9.7 Flare Fittings Required

All oil supply and return lines of copper tubing must be connected by flare fittings only. All fittings must be accessible for service or replacement. No compression fittings shall be used on a supply or return oil line unless it is for the introduction of the lines at the top of the tank with a single or double tap bushing.

11.9.8 Flare Frost Fittings Required Outside

All connections of supply or return oil lines located outside shall be made with flare frost fittings.

11.9.9 Disconnected Lines

No oil lines or oil devices which are disconnected from an oil supply tank, burner or unit, shall be left open. Any oil line or oil device which is disconnected or discontinued must be sealed or closed with a plug, cap or other approved fitting.

11.9.10 Removal of Unprotected Supply Lines

Unprotected supply lines that are buried and grouted must be removed from service.

11.9.11 Underground Piping: Tanks Over 660 Gallons

If underground or under-slab piping is connected to a tank of over 660 gallons capacity or to tanks with an aggregate capacity of over 1,320 gallons, the installation of the underground piping must meet Department of Environmental Protection requirements. (See Appendix A, Section 4 to Chapter 6 of the Board's rules.)

11.9.12 Reporting of Oil Spills Required

Oil spills must be reported to the Department of Environmental Protection in accordance with Appendix A, Section 2 to Chapter 6 of the Board's rules.

11.10 State Internal Plumbing Rules

All piping and safety controls on domestic water heaters and domestic water connections to boilers and heaters must be made in accordance with the *International Association of Plumbing and Mechanical Officials Uniform Plumbing Code*, 2009 edition, as adopted in Chapter 4 of the rules of the Plumbers' Examining Board.

11.11 Electrical Equipment, Required Control Switches

11.11.1 Thermal Cut-Off Switch

A thermal cut-off switch must be wired into the burner circuit to shut off the burner in the event of a fire at the unit. The switch must be placed at the highest point directly above the unit to be fired with the thermal element pointed downwards and must be placed on the bottom of the floor joist or stringer at the front of the unit. In no case shall it be lower than the point where the flue connector enters the chimney. The switch must be wired to shut off the burner, circulating fan, forced or induced draft fan and any remote oil pump that is not an integral part of the burner. A thermal electric switch is required for each oil-fired unit in a multi-appliance installation.

11.11.1.1 On multi-unit installations, the emergency and thermal electrical switches must be wired in series through individual unit relays so that, if one switch is opened, all equipment will be rendered inoperable whenever the "EMERGENCY" switch is opened.

11.11.1.2 All remote pump sets must have a thermal cut-out switch installed as follows:

1. Maximum of 3feet above pump set;
2. The element must be pointed downwards; and
3. The switch must be supported in accordance with NFPA #70, *National Electrical Code* (2011 edition).

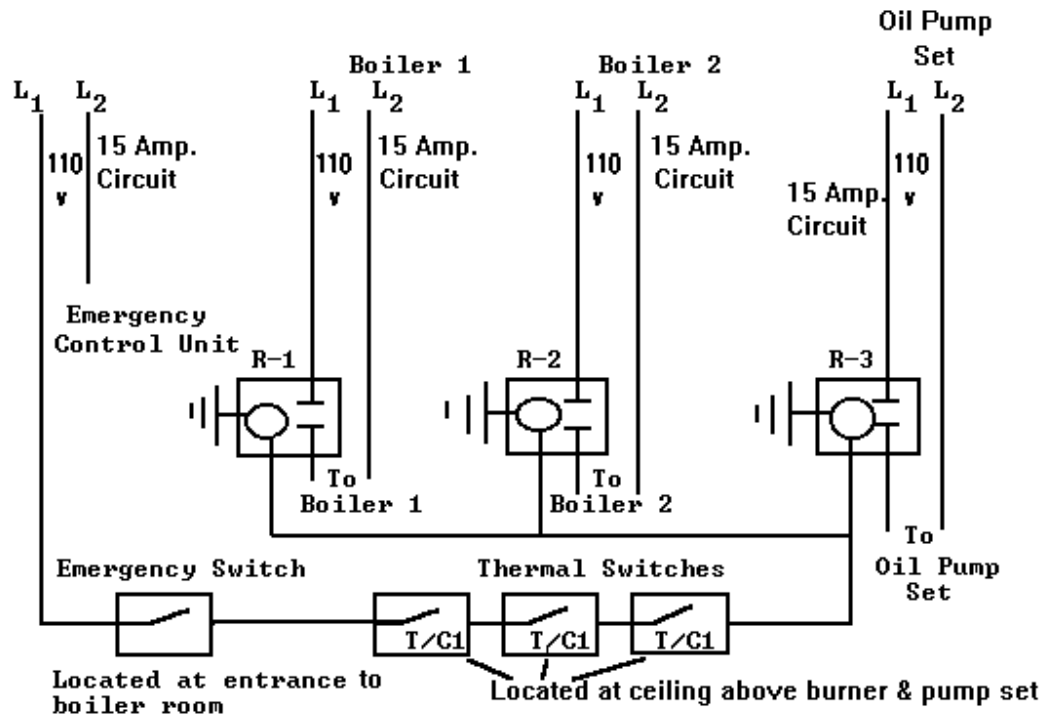

Figure 11-1 For use on commercial and industrial equipment only.
This requirement shall not apply to one and two family residences.

11.11.2 Service Switch

A service disconnect switch for control of the burner while observing the flame must be placed at the unit within arm's reach of the technician.

11.11.3 Emergency Switch

- 11.11.3.1 If the entrance to the boiler room is only accessible from the outside, the emergency switch may be placed at the inside not more than one foot beyond the door opening. An emergency switch shall not be placed outside of any building.
- 11.11.3.2 On commercial and industrial equipment, the emergency switch must be installed in accordance with Figure 11-1 on multi-unit installations. The requirements of Section 11.11.1.1 do not apply to one- or two-family residences.

11.11.3.3 On multi-unit installations, the emergency shut-off switch must be placed at the outside entrance of the room containing the appliances. The emergency switches and the thermal cut-off switches must be wired in series through individual unit relays so that, if the emergency switch is opened, all heating equipment in the room and the remote pump set will be rendered inoperable. This application also applies if there are two or more appliance rooms in the same building that are connected to a common fuel supply system.

11.11.4 Controls Containing Mercury

Thermostats containing mercury must be disposed of in accordance with all federal and state regulations. (Refer to 38 MRSA §1663 and check with your local supplier.)

11.12 Safety and Pressure Relief Valves

11.12.1 Approved Safety or Pressure Relief Valve Required

Steam and hot water boilers must be equipped with listed or approved steam safety or pressure relief valves that conform to ASME requirements. A shut-off valve shall not be placed between the relief valve and the boiler or on discharge pipes between such valves and the atmosphere.

11.12.2 Termination

All steam safety or pressure relief valves must terminate in a manner which precludes the possibility of accidental scalding in accordance with ASME.

11.12.3 Location

Steam safety relief valves over 2 inches in diameter must terminate outside of the structure in a safe location. Steam safety or pressure relief valves which terminate in the structure must terminate 6 inches to 12 inches above the floor.

11.12.4 Installation in Upright Vertical Position

Steam safety and pressure relief valves on boilers must be installed with the spindles in the upright vertical position.

11.13 Water and Steam Boiler Pipe Supports

11.13.1 General

Piping must be supported with pipe hooks, metal pipe straps, bands, brackets, or hangers suitable for the size of the piping and must be of adequate strength and quality and located at intervals so as to prevent or damp out excessive vibration.

11.13.2 Spacing

Spacing of supports shall not be greater than shown in Table 11-1.

11.13.3 Allowance for Expansion and Contraction

Supports, hangers, and anchors must be installed so as to not interfere with the free expansion and contraction of the piping between anchors. All parts of the supporting equipment must be designed and installed so that they will not be disengaged by movement of the supporting piping.

**Table 11-1
Support of Piping**

| Steel Pipe, Nominal Size of Pipe (Inches) | Spacing of Supports (Feet) | Nominal Size of Tubing (Inch O.D.) | Spacing of Supports (Feet) |
|--|----------------------------------|--|----------------------------------|
| 1/2 | 6 | 1/2 | 4 |
| 3/4 or 1 | 8 | 5/8 or 3/4 | 6 |
| 1 1/4 or larger (horizontal) | 10 | 7/8 or 1 | 8 |
| 1 1/4 or larger (vertical) | every floor level | | |

11.14 Emergency Temporary Repair of Warm Air Heat Exchangers

Emergency temporary repairs of warm air heat exchangers in solid fuel burning appliances are allowed if the safety limitations of the repairs are explained in writing to the owner at the time of the repair.

11.15 Welding of Non-Residential Warm Air Heat exchangers

11.15.1 General

Welding of non-residential warm air heat exchangers is permissible only as set forth in this Section. Welding of residential warm air heat exchangers is not permissible under any circumstances.

11.15.2 Consultation With Manufacturer Required

The manufacturer must be consulted to determine whether the welding of a heat exchanger is sound engineering practice. The manufacturer must provide a written statement as to the feasibility of its heat exchanger being welded. If the heat exchanger is no longer in production, a master licensee must make a written request to the Board and obtain written approval from the Board before the repair is undertaken.

11.15.3 Master Licensee to Oversee Welding Repair

The repair of a heat exchanger by welding must be performed by a welder in a procedure suitable for the material. A master licensee must oversee such repairs. The master licensee must receive guidance from the welder as to the feasibility and acceptability of performing the welding procedure of the metals prior to the repair of

any heat exchanger. After completion of said repairs or welding, the master licensee must obtain a written statement from the welder documenting that the heat exchanger has been welded, tested and is acceptable for use without leakage of after-products.

11.15.4 **Documentation of Repair to be Provided to Owner**

Written documentation of said repairs or welding must be provided to the owner. The original documentation must be kept on file by the master licensee who requested the welding. A copy of all the repair documents containing, at a minimum, the following information must be sent to the Board:

1. The name of the owner and location where the repairs were completed;
2. The name and address of the welder;
3. Specific area(s) or location(s) where the repair(s) or welding was performed;
4. Written approval of the repair from the manufacturer where applicable;
5. Equipment identification information, i.e., name, model number, serial number and gross Btu rating; and
6. The name, address, and license number of the master licensee who requested the repair.

11.15.5 **Limitation**

Welding repair of a heat exchanger may be performed only once. A subsequent welding repair may not be made to a heat exchanger unless a master licensee makes written request to the Board and obtains written approval from the Board before the repair is undertaken.

11.16 **Type of Fuel**

11.16.1 **Permissible Fuels**

Waste oil fuel tank(s) may contain: 1 and 2 fuel oils; crankcase oil up to 50 SAE; automatic transmission fluid; and hydraulic oils; and specified refined waste fuels only.

11.16.2 **Prohibited Fuels**

Other types of liquids such as anti-freeze, cleaners, thinners, solvents, gasoline or additives, and any other types of hazardous materials shall not be introduced into a waste oil supply tank.

11.17 **Used Underground Oil Tanks**

Abandoned underground oil storage tanks shall not be used for aboveground storage of oil unless such use has been approved by:

1. The Maine State Fire Marshal; or

2. A Maine licensed professional engineer, or other person meeting the requirements of the statutes and rules governing professional engineers practicing in Maine, certifies that the tank meets all applicable specifications and requirements of NFPA #31, Section 7.2.1 (2011 edition).

11.18 Oil Supply Tank Arrangement

11.18.1 Code Compliance Required

Except as set forth in Section 11.18.2 below, all tanks serving a waste oil appliance must conform to NFPA #31 (2011 edition) and this Chapter.

11.18.2 Exception

A waste oil supply tank of 660 gallons, or two tanks of aggregate capacity, supplying a Waste Oil Appliance must be installed with a receptacle or funnel used specifically for introducing waste oils into a specifically marked waste oil supply tank when the tank and accessories have a 2" diameter (nominal inside diameter) iron pipe vent to the outside of the building or structure.

11.18.3 Arrangement of Waste Oil Tank Recovery Receptacle

The arrangement of the waste oil tank recovery receptacle must comply with the following:

- 11.18.3.1 The recovered waste oil must be introduced into the supply tank manually through a valved recovery pan or funnel for waste oils only and must be located at the top of the tank. See Figure 11-2. The receptacle to receive the oils may be installed as follows:
 1. Install a close x 2" threaded (NPT) metal nipple in the oil supply tank's 2" access opening;
 2. Install the receptacle (funnel, pan, catch basin, etc.) at the top of the valve; or
 3. Install a gauge in the other available access opening of the tank;
- 11.18.3.2 Spillage by individuals pouring recovered waste oil from a pan, catch basin, or other type of recovery container, must be minimized by metal steps, corresponding to the height of the tank, so that an individual does not have to reach beyond his or her shoulder level while transferring the fuel from the recovery container to the oil supply receptacle. Steps provided must be a minimum of 3' wide, with a tread height of not more than 8". Ladders are not an acceptable alternative; and
- 11.18.3.3 Any spillage must be cleaned up immediately and reported to the Department of Environmental Protection.

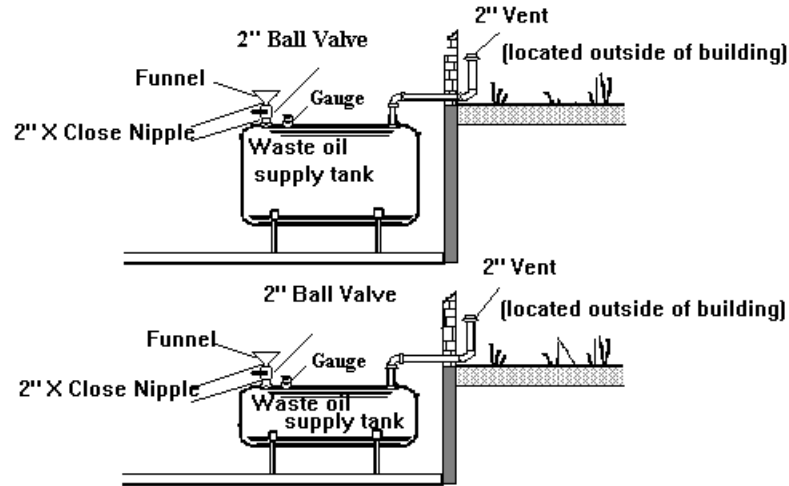

Figure 11-2

Note: The fill pipe can have a tee, a nipple, a manual ball valve and funnel. The funnel shall be constructed and placed so as not to restrict ball valve closure and transfer of oil without spillage. The valve shall not be left open. It is the owner's responsibility to ensure the outsidefill is ready for delivery.

11.18.4 Optional Tank Arrangement

As an option to the tank arrangement in Chapter 11, Section 18(3) and Figure 11-2, the tank arrangement may be supplied with a funnel and a fill and vent pipe extending to the outside, provided that the fill point is identified by a metal placard attached to the building stating: "Waste oil tank, check for inside valve closure prior to filling." See Figure 11-3.

- 11.18.4.1 The waste oil supply tank in Figure 11-3 must be provided with a combination oil gauge and vent alarm at the vent pipe due to the availability of only 3 access openings in the tank. Waste oil tanks with 4 access openings may use a separate gauge and vent alarm.
- 11.18.4.2 Spillage due to pouring recovered waste oil from a pan, catch basin, or other type of recovery container must be minimized by metal steps, corresponding to the height of the tank, so that an individual does not have to reach beyond his or her shoulder level while transferring the fuel from the recovery container to the oil supply receptacle. Steps provided must be a minimum of 3' wide, with a tread height of not more than 8". Ladders are not an acceptable alternative.
- 11.18.4.3 Any spillage must be cleaned up immediately and reported to the Department of Environmental Protection.

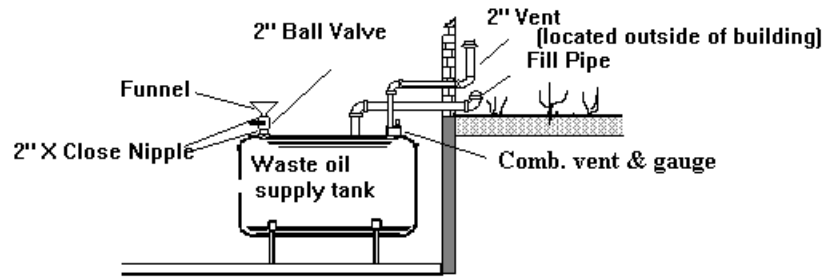

Figure 11-3
Note: Metal placard with 1" letters, must read "Waste Oil Tank, check for inside valve closure prior to filling."

STATUTORY AUTHORITY: 32 MRSA §18123(2)

EFFECTIVE DATE:

September 27, 2014 – filing 2014-244

02 DEPARTMENT OF PROFESSIONAL AND FINANCIAL REGULATION**658 MAINE FUEL BOARD****Chapter 12 PERMITS FOR ABOVEGROUND AND UNDERGROUND PROPANE AND NATURAL GAS STORAGE FACILITIES AND ROOFTOP INSTALLATIONS**

Summary: This Chapter sets forth requirements for permitting aboveground and underground propane and natural gas storage facilities and rooftop installations in Maine.

12.1 Installation**12.1.1 Aboveground and underground propane, compressed natural gas and liquefied natural gas storage facilities**

Installations of aboveground and underground propane, compressed natural gas and liquefied natural gas storage facilities utilizing storage containers of over 2000 gallon individual water capacity, or with aggregate water capacity exceeding 4000 gallons, must be submitted to the Board for approval and permitting prior to installation.

12.1.2 Rooftop Propane Installations

Installations of rooftop propane containers must be installed in accordance with NFPA #58 (2011 edition) and must be submitted to the Board for approval and permitting prior to installation.

12.1.3 Rooftop Compressed Natural Gas Installations

Installations of rooftop compressed natural gas containers must be installed in accordance with NFPA #55 (2010 edition) and must be submitted to the Board for approval and permitting prior to installation.

12.1.4 Rooftop Liquefied Natural Gas Installations

Installations of rooftop liquefied natural gas containers must be installed in accordance with NFPA #59A (2009 edition) and must be submitted to the Board for approval and permitting prior to installation.

12.2 Application Procedure**12.2.1 Generally**

Application for a permit must be made on a form supplied by the Board. The application must be accompanied by detailed plans, including a cross-sectional view, front and side elevations, and plot plans, and the fee set forth in Chapter 10, Section 5(17-A) of the rules of the Office of Professional and Occupational Regulation, entitled "Establishment of License Fees. A permit must be obtained prior to commencement of the installation or alteration.

12.2.2 **Change in Tank Capacity, Piping or Operation**

Any physical change that would increase the tank capacity or alter the piping or operation of the facility requires that a new application be filed and a new permit be issued.

12.2.2.1 When any individual tank with a water capacity of 5000 gallons or more is replaced, the following must be done:

1. If the facility has not been previously permitted, a new permit must be applied for and granted before the tank is replaced.
2. If the facility has been permitted, the Board must be informed in writing at least 15 days before the tank is replaced.

12.3 **Inspection Required Prior to Placing in Operation**

When the installation or alteration is completed, the person making the installation or alteration must notify the Board. A Board inspector shall inspect the installation within a reasonable time so as not to cause undue delay in the progress of the construction contract or installation. The inspector shall determine whether the installation complies with all applicable statutes and rules. If the inspector determines that the installation does not comply, the facility must not be placed into operation and the procedures set forth in 32 MRSA §18110 apply.

STATUTORY AUTHORITY: 32 MRSA §18123(2)

EFFECTIVE DATE:

September 27, 2014 – filing 2014-245

02 DEPARTMENT OF PROFESSIONAL AND FINANCIAL REGULATION**658 MAINE FUEL BOARD****Chapter 13 INSTALLATION OF PROPANE AND NATURAL GAS BURNING EQUIPMENT**

Summary: This Chapter sets forth requirements for the installation of propane and natural gas burning equipment and describes the necessary safety controls, devices and standards for the reduction of fire hazards associated with propane- and natural gas-fired equipment used in residential, commercial, and industrial applications.

13.1 Workmanship

All work must be conducted, installed, and completed in a neat and professional manner reflecting a minimum level of competent workmanship.

13.2 Repair or Replacement

Repair of any system or replacement of parts may be made in the same manner as it was in the existing system provided that such repair or replacement is not hazardous. All material, equipment and devices must be constructed and installed in accordance with their specific purposes and listings.

13.3 Maintenance**13.3.1 General**

All gas burning equipment and systems, both new and existing, and parts thereof must be maintained in a safe condition.

13.3.2 Notification to Homeowner of Code Violations

When performing any service on a customer's gas system, the licensee must notify the homeowner of any code violations and make recommendations to address them.

13.3.3 Combustion Efficiency Test Required

When performing an annual tune-up on a gas-fired central heating system, a combustion efficiency test must be conducted and a copy of the test results must be posted on-site.

13.4 Installations**13.4.1 Code Compliance Required Prior to Firing**

Whenever a furnace, direct-fired hot water heater, or boiler is installed, the total installation must be brought into compliance with the requirements of NFPA #54 (2012 edition), NFPA #58 (2011 edition) and all other rules of the Board **BEFORE** the furnace, direct-fired water heater, or boiler is fired. Prior to leaving the

installation (whether installed inside or outside any structure) unsupervised, the licensed propane and natural gas technician must observe, inspect, and test the equipment to ensure that the installation is operating safely and properly and meets all applicable rules of the Board.

13.4.2 **Additional Requirements**

When an appliance other than a furnace, direct-fired water heater, or boiler is installed, the following must be done:

1. The entire gas piping system must be brought into compliance with the requirements of NFPA #54 (2012 edition) and all other rules of the Board;
2. All appliances which are designed to be vented, including existing appliances, must be vented in accordance with NFPA #54 (2012 edition);
3. Any existing code violations must be reported to the owner in writing, a copy of which must be retained by the installer such that it may be produced for inspection upon request of a Board inspector.

13.4.3 **Vented Central Heating Appliance Required**

When installing a vented central heating appliance, the installer must conduct a combustion efficiency test, unless prohibited by the manufacturer, and must post a copy of the test results on-site.

13.5 **Low Water Control for Boilers**

13.5.1 **Low Water Control Required**

All gas-fired boilers must be provided with a properly installed and operating low water cut-off.

13.5.2 **Location**

The low water cut-off may be installed in or attached to the boiler at the level recommended by the boiler manufacturer, but in no case shall the low water cut-off be installed below the crown sheet. The low water cut-off, when not installed directly in the boiler, may be installed either in the main supply line (vertical riser) as close to the boiler as possible or in a water column of continuous piping attached directly to the boiler.

13.5.3 **Appropriate Design**

The low water cut-off must be designed and approved for the medium used (steam or water).

13.5.4 **No Obstructions**

No valves or other obstructive devices shall be installed between the boiler and safety controls.

13.5.5 **Acceptable Manufacturer's Alternatives**

Installations meeting the criteria of Chapter 10, Section 10.3.5 of NFPA #54 (2012 edition) shall be accepted as meeting the provisions of this Section.

13.5.6 **Additional Acceptable Manufacturer's Alternatives**

A pressure switch installed by the manufacturer and specified by the manufacturer as low-water protection shall be accepted as meeting the criteria of Chapter 10, Section 10.3.5 of NFPA #54 (2012 edition).

13.6 **Heat Loss Requirement**

13.6.1 **New Installations of Central Heating Systems**

Heat loss system design and system load calculations for all new installations of a central heating system must be performed prior to installation. The licensee must retain a copy of the heat loss system design and system load calculations such that it may be produced for inspection upon request of a Board inspector.

13.6.2 **Replacement of Central Heating Systems**

A heat loss and/or load calculation must be conducted before replacement of a central heating system. The licensee must retain a copy of the heat loss system design or system load calculations, or the stamped plans of an engineered system, such that they may be produced for inspection upon request of a Board inspector.

13.7 **Conversion Burners**

13.7.1 **400,000 btu or less**

When converting to propane or natural gas from another fuel source of which the input of the burner is 400,000 btu or less, the following requirements must be met:

1. The conversion burner must be a listed conversion burner.
2. The installer must obtain written verification from the manufacturer of the appliance to be converted or the burner manufacturer that the appliance is capable of being used with gas as a fuel source.
3. The burner selection criteria included in ANSI Z21.8, and the appliance and/or burner manufacturer's combustion setup instructions must be used.
4. If the appliance being converted is designed to operate with a positive chamber pressure, the appliance manufacturer or the conversion burner manufacturer must provide installation and setup instructions specific to the appliance being converted.
5. The installation must conform to NFPA #54 (2012) and ANSI Z21.8, as incorporated by reference into NFPA #54 (2012).

13.7.2 Greater than 400,000 btu

When converting to propane and natural gas from another fuel source of which the input of the burner is over 400,000 btu, the burner must be listed by Underwriters' Laboratory or by an independent nationally recognized testing laboratory and the following requirements must be met:

1. The installer must obtain written verification from the manufacturer of the appliance to be converted or the burner manufacturer that the appliance is capable of being used with gas as a fuel.
2. The burner must be selected for use in the make and model of appliance in which it is intended to be installed and must meet one of the following conditions:
 - A. The burner manufacturer must provide written documentation that the burner has been approved by the burner manufacturer for use in the appliance intended to be converted;
 - B. The burner has been tested by an independent testing laboratory in the make and model of appliance in which it is intended to be installed and has been certified for use in such appliance by the nationally recognized independent testing laboratory;
 - C. The burner has been tested by the appliance manufacturer in the make and model appliance in which it is intended to be installed and has been approved for use in such appliance by the appliance manufacturer.

[NOTE: The appliance and/or burner manufacturer must provide installation and combustion set-up instructions for the appliance being converted.]

3. The installation must conform to the requirements of NFPA #54 and NFPA #211 for the installation of a gas appliance.
4. For installations 1,000,000 btu or greater, the installation must conform to ASME CSD-1 (2012 edition) and NFPA # 85 (edition 2015), as applicable.

13.7.3 Oil Tank Requirements Upon Conversion to an Alternative Fuel

If an oil burning appliance is converted to an alternative fuel, but the tank is left in place so that it can be returned to service at some future date, the following requirements must be met before the alternative fuel is used:

1. The vent piping must remain intact and open to the outside of the building;
2. The fill pipe must be removed completely and the tank must be plugged with a threaded black iron plug;
3. The burner supply line must be removed and the valves on both the tank and burner must be capped or plugged; and
4. The requirements of this Section must be performed by a master or journeyman Oil Burner Technician.

13.8 Electrical Wiring and Equipment

13.8.1 Code Compliance; General Requirements

The following requirements must be met with respect to the electrical wiring and equipment used in connection with propane or natural gas burning equipment:

1. The electrical wiring and equipment used must be installed in accordance with NFPA #70, *National Electrical Code* (2011 edition);
2. Safety control circuits must be two-wire, one side grounded, having a nominal voltage not exceeding 150 Volts. A safety control or protective device must be connected so as to interrupt the ungrounded conductor; and
3. The control circuit must be connected to a power supply branch circuit fused at not more than the value appropriate for the rating of any control or device included in the circuit.

13.8.2 Emergency Switch

- 13.8.2.1 For central heating equipment and water heating appliances where the interruption of an electrical circuit will arrest the combustion process, an identified emergency shutdown switch must be placed outside of and adjacent to the entrance of the room where the appliance is located.
- 13.8.2.2 An emergency switch shall not be placed outside of any building.
- 13.8.2.3 If the entrance to the boiler room is only accessible from the outside, the emergency switch may be placed at the inside not more than one foot beyond the door opening.
- 13.8.2.4 On multi-unit installations of commercial and industrial equipment, the emergency switch must be installed in accordance with Figure 13-1.
- 13.8.2.5 On multi-unit installations in other than one- and two-family residences, the emergency shut-off switch must be placed at the outside entrance of the room containing the appliances. The emergency switches and the thermal cut-off switches must be wired in series through individual unit relays so that, if the emergency switch is opened, all heating equipment in the room and any electrically operated gas valves will be rendered inoperable. This application also applies if there are two or more appliance rooms in the same building that are connected to a common fuel supply system.

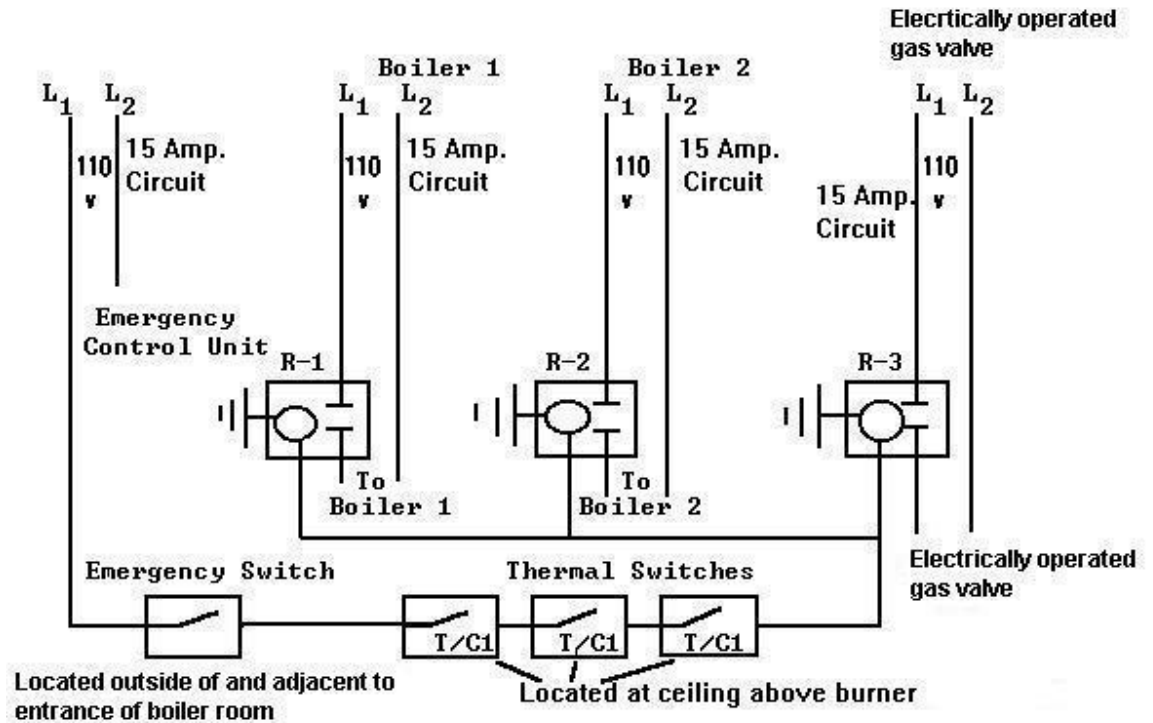

Figure 13-1 For use on commercial and industrial equipment only.
This requirement shall not apply to one and two family residences.

13.8.3 Service Switch

For central heating equipment and water heating appliances where the interruption of an electrical circuit will arrest the combustion process, a service disconnect switch for control of the burner while observing the flame must be placed at the unit, within 3' of the burner.

13.8.4 Thermal Cut-Off Switches

13.8.4.1 For central heating equipment and water heating appliances where the interruption of an electrical circuit will arrest the combustion process, a thermal cut-off switch must be wired into the burner circuit to shut off the burner in the event of a fire at the unit. The switch must be placed at the highest point directly above the unit to be fired with the thermal element pointed downwards, and must be placed on the bottom of the floor joist or stringer at the front of the unit. In no case shall it be lower than the point where the flue connector enters the chimney. The switch must be wired to shut off the burner, circulating fan, forced or induced draft fan and any electrically-operated gas valves. A thermal electric switch is required for each electrically-powered gas-fired unit in a multi-appliance installation.

13.8.4.2 On multi-unit installations other than one- and two-family residences the emergency and thermal electrical switches must be wired in series through individual unit relays so that, if one switch is opened, all equipment will be rendered inoperable whenever the "EMERGENCY" switch is opened.

13.8.5 Controls Containing Mercury

Thermostats containing mercury must be disposed of according to all federal and state regulations. (Refer to 38 MRSA §1663 and check with your local supplier.)

13.9 Steam Boilers

Steam boilers must be installed according to manufacturer's instructions.

13.10 Safety and Pressure Relief Valves

13.10.1 Approved Safety or Pressure Relief Valve Required

Steam and hot water boilers must be equipped with listed or approved steam safety or pressure relief valves that conform to ASME requirements. A shut-off valve shall not be placed between the relief valve and the boiler or on discharge pipes between such valves and the atmosphere.

13.10.2 Proper Termination Required

All steam safety or pressure relief valves must terminate in a manner which precludes the possibility of accidental scalding in accordance with ASME.

13.10.3 Location

Steam safety relief valves over 2 inches in diameter must terminate outside of the structure in a safe location. Steam safety or pressure relief valves which terminate in the structure must terminate 6 inches to 12 inches above the floor.

13.10.4 Installation in Upright Vertical Position

Steam safety and pressure relief valves on boilers must be installed with the spindle in the upright vertical position.

13.11 Water and Steam Boiler Pipe Supports

13.11.1 Generally

Piping must be supported with pipe hooks, metal pipe straps, bands, brackets or hangers suitable for the size of the piping and must be of adequate strength and quality and located at intervals so as to prevent or damp out excessive vibration.

13.11.2 Spacing

Spacing of supports shall not be greater than as shown in Table 13-1.

13.11.3 Allowance for Expansion and Contraction

Supports, hangers, and anchors must be installed so as to not interfere with the free expansion and contraction of the piping between anchors. All parts of the supporting equipment must be designed and installed so that they will not be disengaged by movement of the supporting piping.

**Table 13-1
Support of Piping**

| Steel Pipe, Nominal Size of Pipe (Inches) | Spacing of Supports (Feet) | Nominal Size of Tubing (Inch O.D.) | Spacing of Supports (Feet) |
|--|---|---|---|
| 1/2 | 6 | 1/2 | 4 |
| 3/4 or 1 | 8 | 5/8 or 3/4 | 6 |
| 1 1/4 or larger (horizontal) | 10 | 7/8 or 1 | 8 |
| 1 1/4 or larger (vertical) | every floor level | | |

13.12 State Internal Plumbing Rules

All piping and safety controls on domestic water heaters and domestic water connections to boilers and heaters must be made in accordance with the *International Association of Plumbing and Mechanical Officials Uniform Plumbing Code*, 2009 edition, as adopted in Chapter 4 of the rules of the Plumbers' Examining Board.

13.13 Residential Dryer Exhaust Terminations

The Board considers the exhaust terminations of residential dryers to be openings into the building and not ignition sources.

13.14 Underground Gas Piping

13.14.1 Electrically Insulating Fitting Required

When metallic piping is buried underground, an electrically insulating (dielectric) fitting must be installed before the entrance of the piping into the building. In no case shall the fitting be located after the connection of a bond wire for use with corrugated stainless steel tubing (CSST) or other piping material.

13.14.2 Limitation on Use of Flare Fittings

No flare fittings shall be located underground, unless specifically rated for such use and protected from corrosion in accordance with the manufacturer's instructions.

13.14.3 Protection of metallic piping from corrosion

All underground metallic piping must be protected from corrosion. This may be accomplished by sleeving, using a PVC coated pipe material approved for direct burial, or by other corrosion prevention material listed for such use.

13.15 Liquefied Petroleum Gas, Liquefied Natural Gas and Compressed Natural Gas Containers

13.15.1 Identification of Tank Owner; Consumer-Owned Tanks

All liquefied petroleum gas, liquefied natural gas and compressed natural gas containers installed at a consumer site must be identified as follows:

1. The name of the tank owner must be clearly marked in letters which are a minimum of 1 inch high;
2. The 24-hour emergency contact number of the tank owner must be marked in numbers which are a minimum of 1 inch high;
3. On tanks which are consumer-owned, the tank must be marked "Consumer Owned" in letters which are a minimum of 1 inch high; and
4. Underground tanks must have the above information clearly marked on the inside of the dome cover.

13.15.2 Accessibility of Underground Tanks

Underground containers must be installed such that the top of the attached dome is a minimum of 6 inches above finished grade.

13.16 Vehicle Protection Requirements for Tanks, Gas Piping and Associated Accessory Equipment

[NOTE: Appendix G to Chapter 6 of the Board's rules is a concise summary of the vehicle protection requirements set forth in this Section.]

13.16.1 Responsibility of Installer

It is the responsibility of the licensee installing the tank(s)/outside piping to provide vehicle protection to the tank(s), outside piping or accessory equipment at time of installation.

13.16.2 Responsibility of Delivery Technician

It is the responsibility of the delivery technician to assure that all gas tanks and associated piping and accessory equipment are protected from vehicular damage prior to delivering gas to that system.

13.16.3 Spacing

There must be a maximum of 3' of space between pieces or sections of protection.

13.16.4 Guardrail

Guardrail posts must be set in a minimum of 3' below grade and extend a minimum of 36" above finished grade.

13.16.5 **Bollards**

Bollards must be set below grade in cement and must extend a minimum of 36" above finished grade.

13.17.5.1 Bollards protecting vapor systems must be at least 4" in diameter and filled with concrete.

13.17.5.2 Bollards protecting Bulk Plants and Dispensers must be at least 6" in diameter and filled with concrete.

13.16.6 **Wooden Posts**

Wooden posts must consist of a minimum 6" x 6" pressure-treated material and must extend at least 36" above finished grade.

13.16.7 **Boulders**

Boulders at least 36" in diameter and meeting the spacing criteria of subsection 3 above may be used.

13.16.8 **Concrete Barriers and Blocks**

Concrete barriers and blocks at least 36" high and meeting the spacing criteria of subsection 3 above may be used.

13.16.9 **Non-Standard Protection Systems**

Non-standard engineered vehicle protection systems must be reviewed and approved by the Board prior to being placed into service.

13.16.10 **Plastic Barriers**

Plastic "Type K" barriers filled with sand which meet the height and space criteria of this Chapter may be used.

13.17 **Installation of Self-Service Dispensing Stations**

All installations of self-service dispensers at dispensing stations must comply with the following requirements:

13.17.1 **Operating Instructions**

Operating instructions must be conspicuously posted in the dispensing area;

13.17.2 **View of Operator**

The dispensing area must be in clear view of the operator on duty at all times;

13.17.3 **Communications**

The operator must be able to communicate with persons in the dispensing area at all times.

13.17.4 **Warning Signs**

Warning signs incorporating the following or equivalent wording must be conspicuously posted in the dispensing area:

1. “The filling of portable propane and natural gas containers is prohibited;”
2. “No Smoking;”
3. “Stop Motor and Extinguish All Pilots - Extinguish all pilots and gas ignition systems. All appliances must be in the ‘off’ position;” and
4. “Remove All Occupants from Vehicles Containing Propane Appliances.”

13.17.5 **Emergency Breakaway Device**

The dispensing station must have an emergency breakaway device under the dispensing unit that will retain the product on both sides of the breakaway point, or other devices affording equivalent protection.

13.17.6 **Thermally Activated Shut-off**

The dispensing station must have a thermally activated shut-off.

13.17.7 **Listing**

Motor fuel dispensing devices for compressed natural gas, liquefied natural gas, and liquefied petroleum gas must be listed.

13.17.8 **Hose Assemblies**

Listed hose assemblies must be used to dispense fuel. Hose length at automotive service stations must not exceed 18 feet (5.5 meters).

13.17.9 **Dispensers Beneath Canopies**

Where compressed natural gas or liquefied natural gas dispensers are installed beneath a canopy or enclosure, the following requirements must be met:

- 13.17.9.1 The canopy or enclosure must be designed to prevent accumulation or entrapment of ignitable vapors; and
- 13.17.9.2 All electrical equipment installed beneath the canopy or enclosure must be suitable for Class I, Division 2 hazardous (classified) locations.

13.17.10 **Code Compliance Required: LP, LNG, CNG Dispensers**

Dispensing devices for liquefied petroleum gas (LP), liquefied natural gas (LNG) or compressed natural gas (CNG) must meet all requirements of Chapter 12 of NFPA #30A (2012 edition), as well as the appropriate Sections of NFPA #58 (2011 edition) for LP, and NFPA #52 (2010 edition) for LNG & CNG dispensers.

STATUTORY AUTHORITY: 32 MRSA §18123(2)

EFFECTIVE DATE:

September 27, 2014 – filing 2014-246

AMENDED:

December 8, 2015 – Section 13.7 added, filing 2015-240

Appendix A

DEPARTMENT OF ENVIRONMENTAL PROTECTION OIL REGULATIONS

The Department of Environmental Protection's Bureau of Remediation and Waste Management regulates underground oil storage tanks and the cleanup of any discharge of oil onto or into land or waters of the State of Maine.

1. Underground Oil Storage Tanks:

All underground oil storage tanks must be installed by a person who is licensed by the Board of Underground Storage Tank Installers. The installation and operation of the tank is regulated by the Department of Environmental Protection.

2. Reporting Oil Spills:

To avoid fines or civil penalties, oil spills onto or into the lands or waters of the State of Maine must be reported within 2 hours to the Department of Environmental Protection. To report a leak, call the 24 hour response line at 1-800-482-0777.

3. Abandonment of Tank by Removal:

Tanks must be disposed of in accordance with the Department of Environmental Protection Rules. Used, underground, oil storage tanks are prohibited from use for aboveground supply of oil except where a Maine registered engineer certifies that the tank meets the requirements of UL 142 and NFPA 30.

4. Underground Piping and Aboveground Tanks with Over 660 Gallons or Aggregate Volume Over 1320 Gallons

If underground or under-slab piping is to a tank of over 660 gallons capacity or to tanks with an aggregate capacity of over 1320 gallons, then the installation of the underground piping must be installed by a certified underground oil tank installer.

- A. Piping must be installed by a certified underground oil tank installer as required under 38 MRSA §570-K, Above ground oil storage facilities.
- B. Piping must be constructed of fiberglass, cathodically protected steel, or other equally noncorrosive material approved by the Department of Environmental Protection as required under Chapter 691, Rules for Underground Oil Storage Facilities.
- C. Piping installed on or after June 24, 1991 must include secondary containment and leak detection as required under Chapter 691, Rules for Underground Oil Storage Facilities.
- D. Piping that is "grouted," such as piping run on the surface of a floor and then encased in grout or cement or some similar material, shall be considered underground piping. Such grouted piping must include secondary containment and leak detection as required under Chapter 691, Rules for Underground Oil Storage Facilities.

5. For more information about the Department of Environmental Protection's regulations, contact them at:

Maine Department of Environmental Protection
Bureau of Remediation and Waste Management
17 State House Station
Augusta, Maine 04333
(207) 287-2651

Appendix B
CHAPTER 425
DEPARTMENT OF ENVIRONMENTAL PROTECTION
Asbestos Regulations

The Department of Environmental Protection's Bureau of Remediation and Waste Management regulates the handling of friable asbestos in the State of Maine. It is also regulated by the Federal Occupational Safety and Health Administration (OSHA).

Friable asbestos is material containing asbestos that is loose, crumbly, or can otherwise easily give off fibers and non-friable material that is processed and becomes loose or crumbly. Asbestos used on boilers, pipes, and tape on air ducts is friable.

The state certifies individuals and licenses companies that work with asbestos. It also sets standards for handling and disposing of asbestos. Anyone impacting more than three square feet or three linear feet of asbestos must be certified and licensed by the DEP, except that licensed oil burner technicians are exempt from certification and licensing requirements when conducting an emergency repair, installation, removal or servicing of heating equipment in single-family homes. An emergency is defined to include: a sudden, unexpected event that, if not immediately attended to, presents a safety or health hazard; operations necessitated by non-routine failures of equipment or to protect equipment from damage; and actions of fire and emergency medical personnel pursuant to duties within their official capacities. However, the oil burner technicians who are exempt from certification and licensing are still required to comply with all of the notification, handling, and disposal requirements.

For more information about the asbestos regulations, including a list of licensed contractors and disposal facilities, contact:

| | |
|--|----------|
| Asbestos Unit, Coordinator Maine Department of Environmental Protection Bureau of Remediation and Waste Management 17 State House Station Augusta, Maine 04333 | 287-2651 |
|--|----------|

| | |
|--|----------|
| Occupational Safety and Health Administration 40 Western Avenue Augusta, Maine 04330 | 622-8417 |
|--|----------|

In addition, the Safety Division of the Maine Bureau of Labor Standards offers free consultations. Contact them at:

| | |
|--|----------|
| Safety Division Bureau of Labor Standards 82 State House Station Augusta, Maine 04333 | 624-6460 |
|--|----------|

APPENDIX C
MEMORANDUM OF UNDERSTANDING BETWEEN THE MAINE FUEL BOARD AND THE
PLUMBERS' EXAMINING BOARD FOR THE
INSTALLATION OF HOT WATER OR STEAM & WARM AIR HEATING SYSTEMS,
RADIATION SUPPLY AND RETURN CONNECTIONS

OIL AND SOLID FUEL FIRED SYSTEMS
ALL TASKS TO BE PERFORMED UNDER THE SUPERVISION
AND RESPONSIBILITY OF A LICENSED MASTER OIL AND SOLID FUEL BURNER
TECHNICIAN

**A Master Plumber or a Journeyman Plumber,
under the employment or direction of a
Master Plumber**

SHALL NOT

1. Pipe oil tank or run pipe from tank to oil burner;
2. Install any electric wiring unless he or she is licensed to do so;
3. Install any safety equipment;
4. Install any portion of the venting system; and
5. Install thermostat and relays.

**A Master Plumber or a Journeyman Plumber,
under the employment and direction of a
Master Plumber**

MAY INSTALL

1. Radiation, supply mains and returns, fittings, vents, gate valves, ball valves, zone valves, check valves or other valves that apply directly to the mechanical function of the heating system. This section does not apply to Safety Valves;
2. Connect mains and returns to boiler;
3. Connect make-up water to boiler;
4. Install back flo preventer; and
5. Connect domestic water piping to tankless, indirect or direct fire water heater.

**A Master Plumber or a Journeyman Plumber
holding an Apprentice Oil Burner license
under the direct supervision of a Master Oil
and Solid Fuel Technician**

MAY

1. Set boiler;
2. Set warm air furnaces, install plenums, warm air and return ducts, registers and piping; and
3. Set direct fire & indirect water heaters

A Master Oil and/or Solid Fuel Technician;

**A Journeyman Oil and/or Solid Fuel
Technician, under the indirect supervision of
a Master Oil and/or Solid Fuel Technician; or**

**An Apprentice Oil and/or Solid Fuel
Technician, under the direct supervision of a
Master or Journeyman Oil and/or solid Fuel
Technician**

MAY

1. Set boiler;
2. Pipe radiation, vents, valves, etc.;
3. Install mains and returns;
4. Connect mains and returns to boiler;
5. Connect make-up water to boiler;
6. Install back flo preventer;
7. Install and pipe oil tank;
8. Install set pump, if necessary;
9. Connect oil piping to boiler;
10. Install smoke pipe;
11. Install safety equipment to include safety valves;
12. Install thermostats and relays;
13. Install electric wiring to a breaker or fuse box; and
14. Connect a tankless, indirect or direct fired water heater to existing piping within the room in accordance with 32 MRSA §3302.

APPENDIX C (CONTINUED)
PROPANE & NATURAL GAS FIRED SYSTEMS
ALL TASKS TO BE PERFORMED UNDER THE SUPERVISION
AND RESPONSIBILITY OF A LICENSED PROPANE & NATURAL GAS TECHNICIAN WITH
THE APPLIANCE CONNECTION & SERVICE ENDORSEMENT

A Master Plumber or a Journeyman Plumber, under the employment or direction of a Master Plumber

SHALL NOT

1. Install or connect any gas piping;
2. Install any electric wiring unless he or she is licensed to do so;
3. Install any safety equipment;
4. Install any portion of the venting system; and
5. Install thermostat and relays.

A Master Plumber or a Journeyman Plumber, under the employment and direction of a Master Plumber

MAY INSTALL

1. Radiation, supply mains and returns, fittings, vents, gate valves, ball valves, zone valves, check valves or other valves that apply directly to the mechanical function of the heating system. This section does not apply to Safety Valves;
2. Connect mains and returns to boiler;
3. Connect make-up water to boiler;
4. Install back flo preventer; and
5. Connect domestic water piping to tankless, indirect or direct fire water heater.

A Master Plumber or a Journeyman Plumber, holding a Propane & Natural Gas Helper license under the direct supervision of a Propane & Natural Gas technician with the Appliance Connection & Service endorsement

MAY

1. Set boiler;
2. Set warm air furnaces, install plenums, warm air and return ducts, registers and piping; and

3. Set direct fire & indirect water heaters.

A Propane & Natural Gas Technician with the Appliance Connection & Service endorsement or

A Propane & Natural Gas Helper, under the direct supervision of a Propane & Natural Gas technician with the Appliance Connection & Service endorsement,

MAY

1. Set boiler;
2. Pipe radiation, vents, valves, etc.
3. Install mains and returns;
4. Connect mains and returns to boiler;
5. Connect make-up water to boiler;
6. Install back flo preventer;
7. Install gas piping after the second stage regulator;
8. Connect gas piping to boiler;
9. Install the venting system components;
10. Install safety equipment including safety valves;
11. Install thermostats and relays;
12. Install electric wiring to a breaker or fuse box; and
13. Connect a tankless, indirect or direct fired water heater to existing piping within the room in accordance with 32 MRSA §3302.

Date: April 12, 2012
 Barry Austin, Chairperson
 Maine Fuel Board

Date: December 14, 2011
 Michael Lowe, Chairperson
 Plumbers' Examining Board

Appendix D**MEMORANDUM OF UNDERSTANDING BETWEEN THE MAINE FUEL BOARD AND THE
ELECTRICIANS' EXAMINING BOARD
FOR THE INSTALLATION, SERVICE AND REPAIR
OF HOT WATER, STEAM, WARM AIR HEATING SYSTEMS AND
WATER HEATERS**

A person holding a valid State of Maine Master or Journeyman Oil and/or Solid Fuel Technician's license or a Propane and Natural Gas Appliance Connection and Service Technician license may install electrical conductors, including the branch circuit, fittings, devices and raceways for the power and control of oil, solid-fuel, propane or natural gas fired hot water, steam, warm air heating systems and water heaters. The technician may also install, replace or adjust any motor or control on the heating branch circuit as required by the *National Electrical Code*. This also applies to the branch circuit supplying the oil, solid-fuel, propane or natural gas fired water heater.

The technician may install the branch circuit overcurrent device, provided a space in the electrical panel is available. The technician may also install the associated low voltage wiring provided its power supply is fed from the heating branch circuit.

This does not include the wiring of unit and kick space heaters not associated with the heating branch circuit. This does not allow the technician to install receptacles and lighting for servicing the equipment or to wire air conditioning units, evaporators and condensers.

All electrical installations performed must meet the requirements of the National Electrical Code (NFPA 70).

Date: June 17, 2011
Brian McDougal, Chairperson
Electricians' Examining Board

Date: June 9, 2011
Barry Austin, Chairperson
Maine Fuel Board

Appendix E**STATE OF MAINE
EMERGENCY CHIMNEY UPDATE
WAIVER FORM**

Dear Consumer: The State of Maine, Maine Fuel Board adopted the National Fire Protection Association (NFPA) Standard # 31 (2011 edition) which requires that before an existing oil-fired appliance is replaced with a new appliance, the chimney to which it is connected must be lined with an approved lining system. This regulation is intended to protect you, the consumer.

When an emergency situation arises that does not allow adequate time to get the chimney lined and/or repaired before installing the new heating appliance, the licensee may grant a waiver of up to 90 days to make required repairs. It is the licensee's responsibility to ensure that the installation meets all standards adopted by the board and the manufacturer's instructions. The licensee must either install or have installed the required liner or make the proper repairs within the 90 day time period. In cold weather an emergency situation may include, but is not limited to, situations of serious equipment failure, such as a cracked heat exchanger of a warm air furnace or a leaking boiler. Emergency situations may also include failure of equipment that generates hot water, and the unavailability of a chimney professional.

A copy of this waiver must be provided to the building owner and the Maine Fuel Board.

INSTALLER INFORMATION

| | | |
|--------------------|------------------------------|------------|
| Name of Installer: | | License #: |
| D/B/A | | |
| Mailing Address: | | |
| City: | State: | Zip Code: |
| County: | Home Telephone: (____) _____ | |
| | Work Telephone: (____) _____ | |

By my signature, I certify that I will follow-up within 90 days to ascertain if the liner has been installed.

Signature of Installer:

Date: _____

Appendix E (Continued)**CONSUMER INFORMATION**

| | | |
|-------------------|------------------------------|------------------------------|
| Name of Consumer: | | |
| Mailing Address: | | |
| City: | State: | Zip Code: |
| County: | Home Telephone: (____) _____ | Work Telephone: (____) _____ |

By my signature, I certify that I am aware that, if I do not get my chimney lined, I may be in violation of State of Maine Law, 32 MRSA Chapter 139 and a Maine Fuel Board Compliance Officer may contact me.

Signature of Consumer:

Date: _____

Appendix F

STATE OF MAINE CHIMNEY OR FIREPLACE CONSTRUCTION/INSTALLATION DISCLOSURE

Dear Consumer: As of January 1, 1992, State law, specifically 32 MRSA §18108, requires that chimney or fireplace installers provide you with this "Disclosure" prior to the installation or construction of your chimney or fireplace. The purpose of this Disclosure is to inform you that the National Fire Protection Standard #211 (NFPA #211) (2013 edition) is the current standard which applies to all new construction of chimneys and fireplaces. Please note that the State of Maine does not require registration or licensure of chimney or fireplace installers. It is important to realize that many fires are caused each year from improperly constructed fireplaces and chimneys. This disclosure form should help you in making an informed decision as to the abilities of the installer and under what requirements the installation must comply.

INSTALLER INFORMATION

| | | | |
|---|------------------------------|-----------|--|
| Name of Installer: | | D/B/A: | |
| Name of Installer (if incorporated): | | D/B/A: | |
| Legal Address: | | | |
| City: | State: | Zip Code: | |
| County: | Home Telephone: (____) _____ | | |
| | Work Telephone: (____) _____ | | |
| Years of experience doing fireplace or chimney installations: | | | |

CONSUMER INFORMATION

| | | | |
|-------------------|------------------------------|-----------|--|
| Name of Consumer: | | | |
| Mailing Address: | | | |
| City: | State: | Zip Code: | |
| County: | Home Telephone: (____) _____ | | |
| | Work Telephone: (____) _____ | | |

Installer, please give a brief description of installation being offered: _____

I hereby attest that the preceding information provided is true to the best of my knowledge. I also understand that if I fail to conform with the standards as outlined in NFPA #211 that I shall be subject to penalties as outlined in Title 32, MRSA Chapter 139 and the Maine Fuel Board Rules.

Signature of Installer: _____ Date: _____

Appendix G VEHICLE PROTECTION

BARRIERS:

| | |
|-------------------|---|
| Stone: | Minimum 36 inches high Maximum 3 feet between stones |
| Concrete Blocks: | Minimum 36 inches high Maximum 3 feet between blocks |
| Highway Barriers: | Minimum 36 inches high Maximum 3 feet between blocks |

GUARD RAIL:

| | |
|---------------------|--|
| Standard Steel: | Minimum 36 inches high Minimum post depth 3 feet in ground Maximum 3 feet breaks between sections for access |
| Special Engineered: | Must be reviewed and approved by the Maine Fuel Board |

STEEL BOLLARDS: 4 inch minimum diameter filled with concrete
BULK PLANTS AND DISPENSERS -6 inch diameter filled with concrete

Minimum 36 inches high
 Minimum 3 feet below grade in cement (all sizes)
 Maximum 3 feet between bollards

WOODEN POSTS: Minimum 6 inch X 6 inch pressure treated
 Minimum 36 inches high
 Minimum 3 feet below grade in cement
 Maximum 3 feet between posts

Appendix H

MEMORANDUM OF UNDERSTANDING BETWEEN THE MAINE FUEL BOARD AND THE ELECTRICIANS' EXAMINING BOARD FOR THE INSTALLATION OF MINI-SPLIT HEAT PUMPS IN ONE AND TWO-FAMILY DWELLINGS, AND IN EXISTING MULTI-FAMILY DWELLINGS WITH ELECTRIC HEAT

A person holding a valid State of Maine Master or Journeyman Oil Technician (“Technician”) license may install electrical conductors, including the branch circuit, fittings, devices and raceways for the power and control of mini-split air source heat pumps. The Technician may also install, replace or adjust any motor or control on the dedicated heating branch circuit as required by the *National Electrical Code*. The permission granted in this memorandum of understanding assumes that the oil burner technician is competent through education and or experience in the electrical wiring that will be necessary for this heating appliance.

The Technician may install the branch circuit overcurrent device, provided a space is available in the electrical panel without disturbing the existing wiring, and so long as there is adequate capacity available on the service or feeder to properly operate the appliance(s). The Technician may also install the associated low voltage wiring provided its power supply is fed from the heating branch circuit.

The Memorandum of Understanding does not include the wiring of the outdoor service receptacle unless the receptacle is designed and listed as an integral part of the required disconnect switch at the outdoor unit. The Memorandum of Understanding does not include the installation of mini-split heat pump units with a heating or cooling capacity exceeding 36,000 BTU.

All electrical installations performed must meet the requirements of *National Electrical Code* NFPA 70, as adopted by the Electricians’ Examining Board, with any amendments included in the adoption. It is not the intent of the Memorandum of Understanding to eliminate the need for obtaining all required permits prior to the installation of the equipment, subject to the authority having jurisdiction.

Date: October 18, 2013

Brian McDougal, Chairperson
Electricians’ Examining Board

Date: October 22, 2013

Barry Austin, Chairperson
Maine Fuel Board

Appendix I

MEMORANDUM OF UNDERSTANDING BETWEEN THE OIL & SOLID FUEL BOARD AND THE PROPANE AND NATURAL GAS BOARD FOR THE INSTALLATION OF HOT WATER OR STEAM HEATING SYSTEMS

ALL TASKS TO BE PERFORMED
UNDER THE SUPERVISION AND
RESPONSIBILITY OF A LICENSED
MASTER OIL BURNER TECHNICIAN

A Propane and Natural Gas Appliance
Connection and Service Technician licensed
by the Propane and Natural Gas Board with
an Apprentice Oil Burner Technicians
License

MAY:

1. Set oil-fired boiler.
2. Pipe radiation, vents, valves, etc.
3. Install mains and returns to boiler.
4. Connect make up water to boiler.
5. Install backflow preventer.
6. Install electric wiring to a breaker or fuse box, including emergency switch, service switch and thermo fireomatic switch (per Electricians' Examining Board Rules).
7. Connect a tankless or indirect fired water heater within the boiler room or, if not enclosed, with 15' horizontally to the nearest branch water supply.
8. Install safety devices that are not oil specific.

A Propane and Natural Gas Appliance
Connection and Service Technician licensed
by the Propane and Natural Gas Board

SHALL NOT:

1. Pipe or set oil tank or run oil line from tank to burner.

2. Install any safety controls that are oil specific.
3. Install any flue pipe or tie appliance into chimney.
4. Shall not fire or adjust the heating appliance.

ALL TASKS TO BE PERFORMED
UNDER THE SUPERVISION AND
RESPONSIBILITY OF A LICENSED
PROPANE AND NATURAL GAS
APPLIANCE CONNECTION AND
SERVICE TECHNICIAN

A Master or Journeyman Oil Technician
licensed by the Oil and Solid Fuel Board
with a Propane and Natural Gas Helpers
License

MAY:

1. Set propane or natural gas fired boilers.
2. Pipe radiation, vents, valves, etc.
3. Install mains and returns to boiler.
4. Connect make up water to boiler.
5. Install backflow preventer.
6. Install electric wiring to a breaker or fuse box, including service switch (per Electricians' Examining Board Rules).
7. Connect a tankless or indirect fired water heater within the boiler room or, if not enclosed, with 15' horizontally to the nearest branch water supply.
8. Install safety devices that are not propane and natural gas specific.

Appendix I (*Continued*)

A Master or Journeyman Oil Technician
licensed by the Oil and Solid Fuel Board

SHALL NOT:

1. Pipe or set propane tank or run propane or natural gas lines to burner.
2. Install any safety controls that are propane and natural gas specific.
3. Install any flue pipe or tie appliance into chimney.
4. Shall not fire or adjust the heating appliance.

Appendix I *(Continued)*

Date: January 17, 2001
Alan Landeen, Chairperson
Propane and Natural Gas Board

Date: January 25, 2001
James Carey, Chairperson
Oil and Solid Fuel Board