

I-295 Corridor Study

Scarborough-Brunswick

Prepared by
Maine Department of Transportation (MaineDOT)
Bureau of Transportation Systems Planning

May 2010



I-295 Corridor Study

Scarborough-Brunswick

Prepared by

Maine Department of Transportation (MaineDOT)

Bureau of Transportation Systems Planning

May 2010

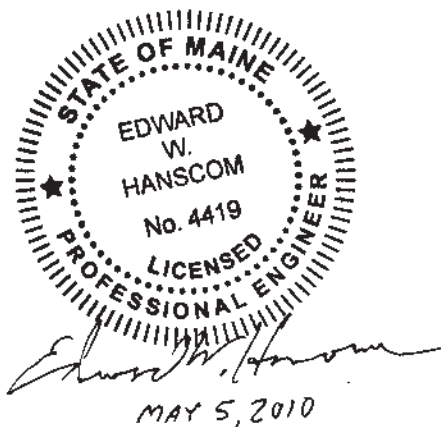

Acknowledgements

MaineDOT

Edward Hanscom, Study Manager
Dennis Emidy, Transportation Engineer

PACTS

John Duncan, Director
Eric Ortman, Transportation Planner
Paul Niehoff, Transportation Planner
Kevin Hooper, Travel Demand Modeler

Other Staff Participants

Ernest Martin, MaineDOT Project Development
Dan Stewart, MaineDOT Bicycle and Pedestrian Program
Sue Moreau, MaineDOT Multimodal Planning & Operations Unit
Russ Charette, MaineDOT Mobility Management Division
Tracy Perez, formerly MaineDOT Office of Passenger Transportation
Gerald Varney, FHWA
John Perry, FHWA
David Willauer, formerly GPCOG
Maddy Adams, GPCOG

Corridor Advisory Committee

Brunswick: Don Gerrish, Town Manager
Theo Holtwijk, Town Planner
Cumberland: Bill Shane, Town Manager
Carla Nixon, Town Planner
Falmouth: George Thebarga, Town Planner
Tony Hayes, Public Works Director
Freeport: Donna Larson, Town Planner
Albert Presgraves, Town Engineer
Maine Turnpike Authority: Conrad Welzel, Manager of Government Relations
Portland: James Cloutier, City Councilor
Larry Mead, Assistant City Manager
Mike Bobinsky, Public Works Director
State Police I-295 Troop: Lieutenant Ron Harmon
Scarborough: Ron Owens, Town Manager
Joe Ziepniewski, Town Planner
South Portland: Tex Haeuser, Planning Director
Steve Johnson, Public Works Director
Transit Providers Working Group: Peter Hefler, METRO General Manager
Westbrook: Paul Boudreau, Public Works Director
Eric Dudley, Chief City Engineer
Yarmouth: Nat Tupper, Town Manager
Dan Jellis, Town Engineer

Cover: I-295 northbound, Exit 3 to Exit 4 (PACTS photo)

Table of Contents

Executive Summary	ES-1
I. Introduction	1-1
A. Background	1-1
B. Purpose and Need	1-2
C. Study Process	1-3
1. Technical Analysis	1-3
2. Public Participation	1-3
II. Existing Conditions	2-1
A. Traffic Volumes	2-1
1. Monthly Variation	2-1
2. Daily Variation	2-3
3. Daily Traffic Flows	2-4
4. Hourly Traffic Flows	2-7
5. Directional Hourly Traffic Variation	2-8
6. Design Hour Volume	2-10
7. Historical Traffic Growth	2-10
B. Existing Conditions Inventory	2-12
1. Roadway Geometry	2-12
2. Highway Safety	2-16
3. Highway Incidents	2-20
C. Mobility and Operating Conditions	2-25
1. Basic Freeway Segments	2-27
2. Freeway Weaving	2-28
3. Freeway Ramp Junctions	2-29

D.	Related Transportation Facilities and Services	2-32
1.	Highways	2-32
2.	Railroads	2-32
3.	Transit and Ridesharing Services	2-33
4.	Park-and-Ride Facilities	2-33
5.	Bicycle and Pedestrian Facilities	2-34
E.	Environmental Overview	2-35
1.	Physical and Biological Environment	2-35
2.	Land Use, Cultural, Social, & Economic Environment	2-35
3.	Atmospheric Environment	2-35
III.	Future Conditions	3-1
A.	Mobility and Operating Conditions	3-1
B.	External Factors and Trends	3-5
IV.	Alternatives Analysis	4-1
A.	Strategies, Actions, and Options	4-1
B.	Auxiliary Lanes	4-3
1.	Weaving Sections	4-5
2.	Acceleration/Deceleration Lanes	4-9
3.	Remaining Capacity Constraints	4-10
C.	Intelligent Transportation Systems	4-11
1.	Traffic Monitoring	4-11
2.	Motorist Information	4-11
3.	Control Center	4-12
4.	Service Patrols	4-12

D.	Transportation Demand Management	4-14
1.	Carpool	4-14
2.	High Occupancy Vehicle Lanes	4-14
3.	Toll Adjustments	4-16
E.	Commuter Transit	4-23
1.	Bus	4-25
2.	Rail	4-25
3.	Ridership	4-25
F.	Interchange Improvements	4-31
1.	Exit 4	4-31
2.	Exit 6	4-33
3.	Exit 11	4-40
4.	Exit 15	4-43
G.	Highway Capacity Increases	4-45
1.	Maine Turnpike (I-95)	4-45
2.	I-295, Exit 2 to Exit 9	4-50
3.	I-295, Exit 9 to Exit 28	4-56
H.	Effectiveness, Cost, and Challenges	4-58
I.	Coordinated Strategies	4-62
V.	Recommendations	5-1
A.	The Need for Flexibility	5-1
B.	Near-Term Improvements	5-2
C.	Long-Term Improvements	5-12

Appendices

1. High Crash Location Diagrams	A-1
2. 2002 AM Design Hour Volume & LOS	A-14
3. 2002 PM Design Hour Volume & LOS	A-16
4. PACTS 2025 No-Build Network Assumptions	A-18
5. 2025 AM Design Hour Volume & LOS	A-22
6. 2025 PM Design Hour Volume & LOS	A-24
7. 2025 AM Auxiliary Lanes DHV & LOS	A-26
8. 2025 PM Auxiliary Lanes DHV & LOS	A-28
9. Interchange Type Diagrams	A-30
10. 2025 AM 6-Lane between Exit 5 & Exit 7 DHV &LOS	A-32
11. 2025 PM 6-Lane between Exit 5 & Exit 7 DHV &LOS	A-34
12. 2025 AM 6-Lanes on MTA DHV &LOS	A-36
13. 2025 PM 6-Lanes on MTA DHV &LOS	A-38
14. 2025 AM 6-Lane between Exit 2 & Exit 9 DHV &LOS	A-40
15. 2025 PM 6-Lane between Exit 2 & Exit 9 DHV &LOS	A-42
16. 2025 AM 6-Lane between Exit 9 & Exit 28 DHV &LOS	A-44
17. 2025 PM 6-Lane between Exit 9 & Exit 28 DHV &LOS	A-46
18. 2025 AM Differential Toll DHV & LOS	A-48
19. 2025 PM Differential Toll DHV & LOS	A-50
20. 2025 AM Commuter Rail DHV & LOS	A-52
21. 2025 PM Commuter Rail DHV & LOS	A-54
22. Commuter Rail Sensitivity Analysis	A-56
23. Enlarged Figures of Improvement Concepts	A-57

Executive Summary

The Maine Department of Transportation, along with the Portland Area Comprehensive Transportation System (PACTS) and other stakeholders, has been conducting a study of Interstate 295. The purpose of the study is to evaluate the long-term needs of the I-295 Corridor between Scarborough and Brunswick and to identify a set of recommendations to provide safe and efficient transportation service through the year 2025. The long-range plans of both MaineDOT (*Connecting Maine*) and PACTS (*Destination Tomorrow*) recognize the need for a highly functioning Interstate Highway System as the backbone of the transportation network statewide and in the Greater Portland Area. The recommendations contained in this study are consistent with both long-range plans. This document summarizes the findings and recommendations of the I-295 Corridor Study and is available for review and comment.

Background

I-295 was constructed as part of the National System of Interstate and Defense Highways (Interstate Highway System), established by Congress in 1956. Most of present-day I-295 through Falmouth, Cumberland, Yarmouth, Freeport, and Brunswick was constructed in the late 1950s and early 1960s and was designated as I-95. In the 1970s, I-295 through South Portland and Portland was constructed to provide Interstate access to the Portland Peninsula and other locations in those two cities. I-95 was extended in the 1970s from Brunswick to Gardiner, which for the most part completed the Interstate Highway System in southern and central Maine. In 2004, the Interstate between Falmouth and Gardiner was redesignated as I-295, while the entire length of the Maine Turnpike was designated as I-95.

Since the 1950s, traffic volumes on I-295 have grown more than fivefold. In 1959, the combined Interstate and Route 1 volume at the Yarmouth-Freeport town line was less than 10,000 vehicles per day. Now, the Interstate alone at that location carries over 50,000 vehicles per day. In the late 1950s, Tukey's Bridge carried less than 20,000 vehicles per day. Now, Tukey's Bridge on I-295 carries approximately 85,000 vehicles per day, making it the most heavily traveled segment of Interstate highway in Maine.

Recognizing in 2000 the increasing strain that higher traffic volumes were placing on I-295, the Joint Standing Committee on Transportation of the 119th Legislature directed MaineDOT to begin looking at opportunities to relieve traffic pressures on I-295, particularly in South Portland and Portland. This effort was followed by a more extensive study, the I-295 Corridor Study.

In 2006, PACTS published its long-range plan, titled *Destination Tomorrow*. One of the four implementation-plan highlights contained in *Destination Tomorrow* is written as follows:

“Continue support of MaineDOT and Maine Turnpike Authority efforts to:

- make necessary investments to provide safe and efficient transportation service on the Interstates through the Year 2025; and
- maintain I-295 as the primary route for intra-regional traffic, and the Maine Turnpike as the major route for traffic traveling through the region.”

PACTS’ full plan can be found at:

http://www.pactsplan.org/destination_tomorrow/currentdt2006.php

Over the past several years, MaineDOT has engaged stakeholders from all over the state in efforts to develop its long-range plan entitled *Connecting Maine*. This plan is constructed around five goals:

- I. Ensure a safe and secure transportation system.*
- II. Ensure the sustainability of Maine’s transportation system.*
- III. Promote economic viability and competitiveness.*
- IV. Enhance quality of life by developing and implementing transportation programs that enhance communities and Maine’s natural environment.*
- V. Enhance public awareness and participation.*

Connecting Maine also identified Maine’s interstate system as a critical factor in the health of Maine’s economy and identified it as a strategic investment area.

Highlights of *Connecting Maine* can be found at:

http://www.maine.gov/mdot/planning-documents/pdf/conn_maine_120607a1.pdf

Purpose and Need

As stated earlier, the purpose of the study is to evaluate the long-term needs of the I-295 Corridor between Scarborough and Brunswick and to identify a set of recommendations to provide safe and efficient transportation service through the year 2025. With the growth of traffic over the years, the capacities of some portions of the Corridor have been severely tested, resulting in chronic traffic congestion and delay, particularly in South Portland and Portland. Incidents anywhere along the highway create traffic hazards that temporarily reduce highway capacity and produce lengthy traffic backups. On- and off-ramps designed nearly 50 years ago are operating poorly under today’s traffic volumes. The goal of the I-295 Corridor Study is to provide a direction for future investments in this corridor to address these deficiencies and ensure that I-295 can function effectively into the future.

Figure 1: Study Area

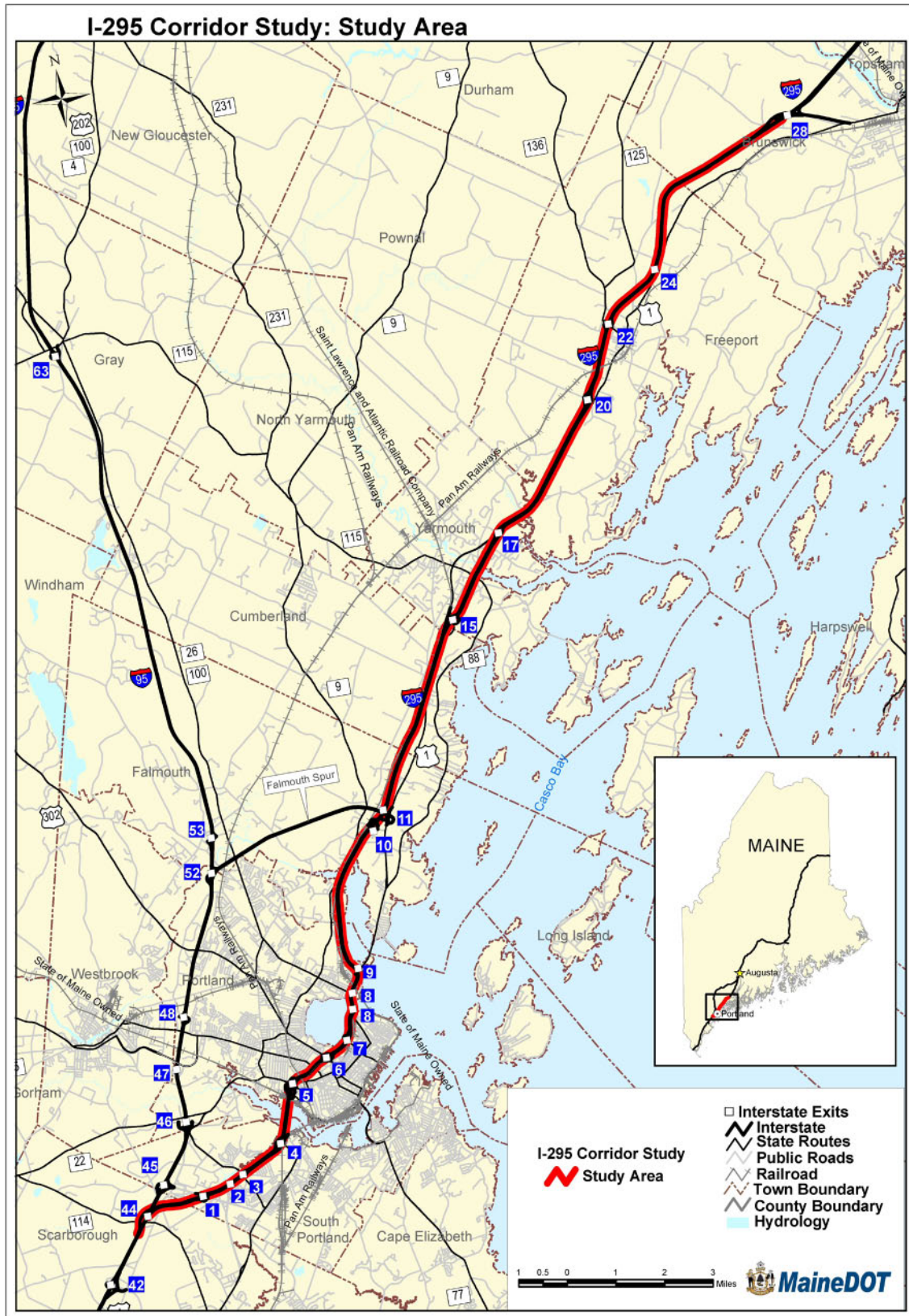

Study Process

After the definition of a study purpose, one of the first steps in the study process was to define a study area for I-295. The I-295 Corridor Study Area extends from the I-295 toll booths at I-95 Exit 44 in Scarborough to the Exit 28 ramps in Brunswick, a distance of 28 miles. This 28-mile length was chosen because it encompasses the most heavily traveled portions of I-295: the urban mileage in South Portland and Portland, and the heavily traveled rural mileage between Portland and Brunswick. The I-295 Corridor Study Area is shown in Figure 1.

The study process has two major components: the technical analysis and public participation. The technical analysis includes a review of existing conditions, a forecast of future conditions, and an analysis of alternative strategies and actions. The technical analysis assessed safety, mobility, cost, and environmental issues. Public participation included three elements: a corridor advisory committee representing public stakeholders throughout the study area, a series of public meetings for direct exchange of information with the general public, and a study Web site serving as a resource to share information about the study. The Web site has been accessible from the MaineDOT home page at:

<http://www.maine.gov/mdot-stage/major-planning-studies/i295corridorstudy/index.php>.

Existing Conditions

The analysis of existing conditions provides a detailed description of the current physical and operating characteristics of the I-295 Corridor. This evaluation required the development of a comprehensive inventory of existing conditions in terms of traffic volume and composition, level of service (LOS), roadway geometry, and crash history. It also serves as a benchmark for analyzing future conditions and comparing potential improvement alternatives. An important product of the existing conditions analysis is the identification of geometric and operational deficiencies in the I-295 corridor that adversely affect its ability to serve safely and efficiently. Also important are the identification of other parts of the regional and local transportation systems that interact with the I-295 Corridor and the overview of the environmental conditions along the I-295 Corridor.

The existing conditions analysis identified several deficiencies that have an adverse effect on the function of I-295. Physically, I-295 has many on- and off-ramps that have inadequate acceleration and deceleration lanes for the volume of traffic that uses them. This results in a poorer level of service at the junctions of these ramps with the I-295 mainline. Some locations in the corridor are considered high crash locations, which have a frequency of crashes that is significantly higher than what would be expected on Interstate highways in Maine. Some locations in the I-295 corridor are operating at or near capacity during the AM and PM peak hours. This results in significant traffic congestion and poor levels of service (E and F). The Corridor Advisory Committee proposed that levels of service be maintained at D or better.

Tables 1 and 2 summarize the number of I-295 mainline locations operating at various levels of service during the AM and PM peak hours. The existing conditions traffic volumes for most locations in the I-295 Corridor were based on counts from 2002, the year with the most complete set of Corridor traffic counts available for the Study.

**Table 1:
2002 LOS AM Peak**

		2002 Level of Service AM Peak					
		A	B	C	D	E	F
On/Off Ramps	Southbound	2	2	18	9	1	0
	Northbound	2	18	10	2	1	0
Segments Between On/Off Ramps	Southbound	3	2	8	6	1	0
	Northbound	2	13	4	2	0	0

**Table 2:
2002 LOS PM Peak**

		2002 Level of Service PM Peak					
		A	B	C	D	E	F
On/Off Ramps	Southbound	2	8	13	7	1	1
	Northbound	1	3	1	23	5	0
Segments Between On/Off Ramps	Southbound	1	9	5	4	1	0
	Northbound	1	2	7	9	2	0

Related to both safety and congestion is the frequent occurrence of traffic incidents in the I-295 corridor. These incidents, which may be a stalled vehicle on the shoulder or a major traffic accident, reduce the capacity of the roadway, create traffic backups, and increase the risk of further serious incidents.

Future Conditions

To evaluate the impact of future travel on the Corridor Study Area, 2025 hourly traffic volume conditions were projected by Portland Area Comprehensive Transportation System (PACTS) Travel Demand Model. The year 2025 was the planning horizon year for the *Destination Tomorrow*, the PACTS long-range plan. The PACTS Travel Demand Model forecast was based on anticipated growth of population and employment in the Greater Portland area. In general, the traffic volume on I-295 was predicted to increase 20% in the next 20 years.

The Year 2025 No-Build assumptions in the PACTS Model include: the I-295 Connector in Portland and other improvements, expanded local bus and van pool service, intercity (AMTRAK) passenger rail south of Portland and north to Brunswick, but no change to the toll collection structure and no widening of the Turnpike north of Exit 44 to six lanes.

The Baseline or No-Build strategy would maintain the existing corridor infrastructure, but would not make any improvements on I-295 or any parallel transportation route that could

affect transportation operations on I-295. The No-Build strategy was used as a base for comparison to other alternatives.

As in the existing conditions analysis, the AM and PM levels of services were evaluated at locations throughout the I-295 Corridor. Tables 3 and 4 summarize the number of mainline locations operating at various levels of service during the AM and PM peak hours. These tables show that, when compared to Tables 1 and 2, the number of locations operating at levels of service E and F under the No-Build strategy would be much higher in 2025 than in 2002.

Table 3: 2025 No-Build LOS AM Peak

		2025 Level of Service AM Peak					
		A	B	C	D	E	F
On/Off Ramps	Southbound	0	4	5	15	7	1
	Northbound	0	13	9	6	3	2
Segments Between On/Off Ramps	Southbound	1	2	6	6	4	1
	Northbound	1	10	4	4	1	1

Table 4: 2025 No-Build LOS PM Peak

		2025 Level of Service PM Peak					
		A	B	C	D	E	F
On/Off Ramps	Southbound	0	8	7	10	1	6
	Northbound	1	2	1	8	17	4
Segments Between On/Off Ramps	Southbound	0	6	7	2	3	2
	Northbound	1	1	2	6	8	3

Many of the locations with poor levels of service would be in Portland and South Portland, where traffic volumes are highest. The worst levels of service are found on the inbound direction (toward Portland) in the AM and in the outbound direction in the PM. Also, in the more northerly rural parts of the I-295 Corridor, ramp levels of service are often worse than the mainline levels of service.

The effects of a poorly-functioning I-295 Corridor would be felt on the local street network. A congested I-295 would cause some motorists to use local arterial and collector streets to reach their destinations. This would, in turn, create more congestion for local travelers. An effective I-295 Corridor would leave the arterial and collector streets to those local travelers that need to use them.

External Factors and Trends

The analysis of 2025 traffic projections in the I-295 Corridor provides a reasonable estimate of future traffic conditions based on anticipated growth of population and employment in the Greater Portland area. However, some external factors and trends, as discussed below, could have a substantial impact on future traffic volumes and congestion levels.

Aging Population

The population of the United States is aging. As the wave of Baby Boomers, born between 1945 and 1965, enter their 60's, 70's, and 80's, the driving habits of a large segment of our population will change. Older people drive less and rely on public transportation more. This trend will tend to slow the growth of automobile travel.

New Technology

Changes in technology continue in the transportation field. Automobiles are increasingly equipped with GPS and sensor technology that allows greater automation in the navigation and control of the vehicle. Automatic sensors and communication devices in highways are providing better information to drivers about conditions ahead. Electronic toll collection without toll booths is available now and spreading across the country. The combination of more intelligent vehicles and highways may lead to greater automation of the driving task and allow the closer spacing of vehicles, and greater vehicular capacities, on controlled access highways.

Energy Costs

Recent experience in Maine has shown that increases in the price of gasoline can reduce automobile travel, at least in the short term. The future price of motor fuels is difficult to predict, but rising demand for fuel in rapidly growing economies in China, India, and other parts of the developing world will put increasing pressure on petroleum supplies and upward pressure on energy prices. These pressures will push transportation in the United States more toward alternative fuels, fuel-efficient vehicles, and other modes of transportation.

Transportation Funding

Transportation funding by conventional motor fuel taxes is unable to keep up with financial demands of maintaining and improving the highway system. Recent trends of higher fuel prices and less dependence on gasoline and diesel fuels, coupled with rising highway and bridge construction costs, are creating a widening gap between revenues and needed expenditures. This trend will push policy makers to find new means of collecting revenue for transportation.

Strategies

To address the existing and future needs of the I-295 Corridor, a broad range of strategies was analyzed. Each strategy represents a different approach toward solving the problems in the I-295 Corridor. Some strategies are oriented toward specific locations in the Corridor while others are corridor-wide. Some are directed at physical improvements to the highway while others are directed at relieving the traffic demand on the corridor.

Within each strategy, there may be one or more actions. The actions are specific projects or programs to address the deficiencies in the I-295 Corridor. Most of these actions are location-specific. Table 5 shows the strategies and actions analyzed for the I-295 Corridor Study.

Table 5: Strategy Characteristics

Strategies	Characteristics
Auxiliary Lanes (lanes to aid getting on and off I-295)	<ul style="list-style-type: none"> • Relatively low cost • Targeted toward specific interchange ramps or short highway segments • For improved efficiency and safety at on-ramps and off-ramps • Example actions: weaving section improvements, improved acceleration and deceleration lanes at interchange ramps
Intelligent Transportation Systems (ITS)	<ul style="list-style-type: none"> • Relatively low cost • Applies improved technology and communications • For improved efficiency of existing facilities • Example actions: variable message signing, traffic surveillance installations, service patrols.
Transportation Demand Management (TDM)	<ul style="list-style-type: none"> • For relief of travel demand in the corridor • Involves incentives to change driver behavior • Example actions: HOV lanes, carpool incentives, toll changes
Commuter Transit	<ul style="list-style-type: none"> • For relief of travel demand in the corridor • Involves alternative transportation facilities and services • Example actions: commuter bus, commuter rail
Interchange Improvements	<ul style="list-style-type: none"> • Major improvements at specific interchanges • Example actions: new ramp configurations, additional ramps
New Highway Capacity (within existing right-of-way; possible minor exceptions)	<ul style="list-style-type: none"> • For added vehicular capacity • Involves construction of additional lanes for use by general traffic • Example actions: new thru lanes

The effectiveness of the strategies in 2025 is summarized in Table 6. Measures of effectiveness include changes in peak hour volume on I-295, vehicle-hours traveled (VHT) and vehicle-miles traveled (VMT), safety, capacity, level of service, access, and parking demand. Effectiveness measurements in green represent beneficial effects. Those in red italics represent negative effects. Most strategies would have the benefits of reduced VHT as well as other benefits. Interchange and new capacity actions would tend to increase VMT while commuter transit actions would tend to decrease VMT.

Table 6: Strategy Effectiveness in 2025

Strategies	Actions	Measurements of Effectiveness			
		Peak Hour Volume Change	VHT Change (for year)	VMT Change (for year)	Other
Auxiliary Lanes	Weaving section improvements in South Portland and Portland		Reduction		Improved capacity and level of service
	Acceleration and deceleration lane improvements at various locations from Falmouth to Freeport		Reduction		Improved level of service
Intelligent Transportation Systems (ITS)	Traffic surveillance and variable message signing in Portland and South Portland		Reduction		Shorter and fewer incidents
	Service patrols		270000		Shorter and fewer incidents
Transportation Demand Management (TDM)	High-occupancy vehicle lanes		Increase or no effect		
	Carpool incentives	-200	Reduction	Reduction	-200 in Portland parking demand
	Differential tolls	-250	-540000	+1.2 million	
Commuter Transit	Commuter bus service to Portland from north and south Commuter rail service to Portland from N/S	-250 (inbound)	-820000	-8.5 million	-250 in Portland parking demand
Interchange Improvements	Added ramps at Exit 4		-50000	-230000	Improved access
	Added ramps at Exit 11		-110000	+200000	Improved access
	Added ramp at Exit 15		Reduction		Improved access and safety at HCL
	Median lanes at Exit 6	+100	-520000	+380000	Improved safety at HCL
New Highway Capacity	Added thru lanes on I-95 in Portland and South Portland (MTA)	-350	-1.7 million	+470000	Improved capacity for lane closure
	Added thru lanes on I-295 in Portland and South Portland	+250	-1.9 million	+850000	Improved capacity for lane closures
	Added thru lanes on I-295 from Falmouth to Brunswick		-1.4 million		Improved capacity for lane closures

Coordinated Strategies

A coordinated strategy is a combination of individual strategies that complement each other toward a common objective. Examples of coordinated strategies include low-cost improvements, improved interchange access to I-295, reduction in travel demand on I-295, and capacity increase on I-295. Table 7 shows how the individual actions can be combined into coordinated strategies.

Table 7: I-295 Coordinated Strategies

Coordinated Strategies	Characteristics
Transportation Systems Management (TSM)	<ul style="list-style-type: none"> • To improve the operation of the existing facilities • Includes intelligent transportation systems and auxiliary lane improvements • Relatively low cost • Relatively minor environmental issues • Compatible with all other coordinated strategies
I-295 Access Improvements	<ul style="list-style-type: none"> • To make physical improvements that enable more travelers to use I-295 interchanges • Mostly moderate in cost
I-295 Traffic Volume Reduction	<ul style="list-style-type: none"> • To redirect traffic to appropriate alternate routes • To encourage travelers to use multi-occupant vehicles • Includes transportation demand management, commuter transit, toll changes, increased capacity on the Maine Turnpike • Low to high in cost • Minor to major environmental issues
I-295 Highway Capacity Increases	<ul style="list-style-type: none"> • To add vehicular capacity through construction of new through lanes on I-295, generally within existing right-of-way • Relatively high in cost • Relatively major environmental issues

The actions within a coordinated strategy can reduce the need for, or the effectiveness of, actions that follow a different coordinated strategy. For example, an action that shifts commuters to transit can reduce the need for additional highway capacity. On the other hand, an action that increases highway capacity can reduce the incentive for commuters to shift from their automobiles to transit. Among the I-295 coordinated strategies, the strategies to reduce I-295 volumes and increase I-295 capacity have the least compatibility. However, both the volume reduction strategy and the increased capacity strategy can be effective strategies for the long term, and both are compatible with TSM improvements and improved interchange access.

Recommendations

The recommendations of the I-295 Corridor Study are a blend of complementary strategies aimed to achieve the study purpose of providing safe and efficient transportation service through the year 2025. The near-term recommendations are a group of specific projects to address the most immediate challenges. These near-term recommendations focus on getting the best operation possible out of the existing highway and making relatively low-cost improvements at specific locations most in need of attention. The long-term recommendations are a combination of improvements to existing infrastructure and new transportation service initiatives to address the needs of 2025. The near-term and long-term recommendations are summarized in Figure 2.

The Need for Flexibility

External factors such as the aging population, new technology, energy costs, and the availability of transportation funding weigh heavily on the future of Maine's transportation system. These factors, along with trends in Maine's regional traffic, economic, and population growth, must be continually monitored to track their direction and anticipate future conditions. The recommendations for the I-295 Corridor must provide a path that gives the Corridor the flexibility necessary to meet the needs of the traveling public, however that future unfolds.

Near-Term and Long-Term

Near-term recommendations must respond to immediate needs, but they should also be compatible with at least three future scenarios: one that requires the management of the corridor as safely and efficiently as possible in a climate of scarce funds, one that requires an adequate response to move people and goods in an expanding economy, and one that requires the corridor to adapt to an era of higher energy costs and greater environmental stewardship. The near-term recommendations for the I-295 Corridor consist of interchange and auxiliary lane improvements to focus on some of the most problematic locations that can be addressed by reasonably affordable actions.

Long-term recommendations must be able to lead the Corridor down the path to any of these three scenarios, which will become clearer as the future trends emerge. It is quite possible that the future of the I-295 Corridor will contain elements of all three scenarios. MaineDOT and PACTS planners will need to monitor conditions in the I-295 Corridor, as well as external factors and trends, to determine the direction of a long-term coordinated strategy.

Some long-term improvements are a continuation of the types of actions included in the short-term recommendations. However, several of the long-term recommendations require more detailed analysis of the proposed actions to assess the feasibility of their implementation and understand their effect on the environment around them. Among those requiring further analysis are actions to implement commuter transit services (currently under study), to create differential tolls on I-295 and I-95, and to increase capacity on portions of I-95 and/or I-295.

Figure 2: I-295 Corridor Study Recommendations

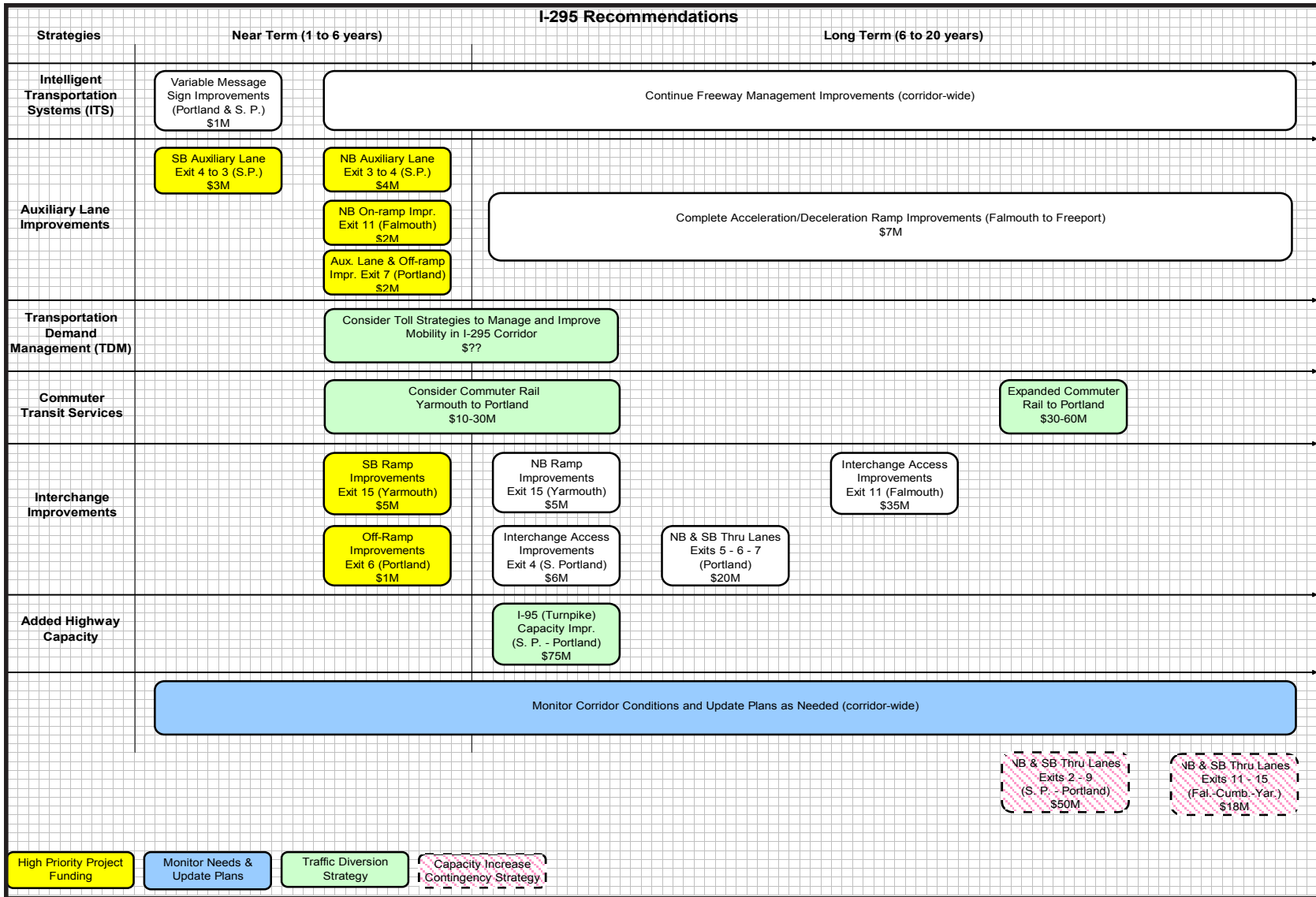

I. Introduction

The Maine Department of Transportation, along with the Portland Area Comprehensive Transportation System (PACTS) and other stakeholders, has conducted a study of Interstate 295. The purpose of the study has been to evaluate the long-term needs of the I-295 Corridor between Scarborough and Brunswick and to identify a set of recommendations to provide safe and efficient transportation service through the year 2025.

A. Background

I-295 was constructed as part of the National System of Interstate and Defense Highways (Interstate Highway System), established by Congress in 1956. Most of present-day I-295 through Falmouth, Cumberland, Yarmouth, Freeport, and Brunswick was constructed in the late 1950s and early 1960s and was designated as I-95. In the 1970s, I-295 through South Portland and Portland was constructed to provide Interstate access to the Portland Peninsula and other locations in those two cities. I-95 was extended in the 1970s from Brunswick to Gardiner, which for the most part completed the Interstate Highway System in southern and central Maine. In 2004, the Interstate between Falmouth and Gardiner was redesignated as I-295, while the entire length of the Maine Turnpike was designated as I-95.

Since the 1950s, car and truck traffic volumes on I-295 have grown more than fivefold. In 1959, the combined Interstate and Route 1 volume at the Yarmouth-Freeport town line was less than 10,000 vehicles per day. Now, the Interstate alone at that location carries over 50,000 vehicles per day. In the late 1950s, Tukey's Bridge carried less than 20,000 vehicles per day. Now, Tukey's Bridge on I-295 carries approximately 85,000 vehicles per day, making it the most heavily traveled segment of Interstate highway in Maine.

Recognizing in 2000 the increasing strain that higher traffic volumes were placing on I-295, the Joint Standing Committee on Transportation of the 119th Legislature directed MaineDOT to begin looking at opportunities to relieve traffic pressures on I-295, particularly in South Portland and Portland. This effort was followed by a more extensive study, the I-295 Corridor Study.

In 2006, PACTS published its long-range plan, titled *Destination Tomorrow*. One of the four implementation-plan highlights contained in *Destination Tomorrow* is written as follows:

“Continue support of MaineDOT and Maine Turnpike Authority efforts to:

- make necessary investments to provide safe and efficient transportation service on the Interstates through the Year 2025; and
- maintain I-295 as the primary route for intra-regional traffic, and the Maine Turnpike as the major route for traffic traveling through the region.”

PACTS’ full plan can be found at:

http://www.pactsplan.org/destination_tomorrow/currentdt2006.php

Over the past several years MaineDOT has engaged stakeholders from all over the State in efforts to develop its long-range plan entitled *Connecting Maine*. This plan is constructed around five goals:

- I. *Ensure a safe and secure transportation system.*
- II. *Ensure the sustainability of Maine’s transportation system.*
- III. *Promote economic viability and competitiveness.*
- IV. *Enhance quality of life by developing and implementing transportation programs that enhance communities and Maine’s natural environment.*
- V. *Enhance public awareness and participation.*

Connecting Maine also identified Maine’s interstate system as a critical factor in the health of Maine’s economy and identified it as a strategic investment area.

Highlights of *Connecting Maine* can be found at

http://www.maine.gov/mdot/planning-documents/pdf/conn_maine_120607a1.pdf

B. Purpose and Need

As stated earlier, the purpose of the study is to evaluate the long-term needs of the I-295 Corridor between Scarborough and Brunswick and to identify a set of recommendations to provide safe and efficient transportation service through the year 2025. With the growth of traffic over the years, the capacities of some portions of the Corridor have been severely tested, resulting in chronic traffic congestion and delay, particularly in South Portland and Portland. Incidents anywhere along the highway create traffic hazards that temporarily reduce highway capacity and produce massive traffic backups. On- and off-ramps designed nearly 50 years ago are operating poorly under today’s traffic volumes. The goal of the I-295 Corridor Study is to provide a direction for future investments in this corridor to address these deficiencies and ensure that I-295 can function effectively on into the future.

It should be emphasized that the needs identified in the I-295 Corridor Study are the functional needs of the corridor - those needs defined by roadway geometry and operation characteristics such as traffic volume, level of service and crash history. Apart from the functional condition of the Corridor is the physical condition of the Corridor, which is defined by structural condition and service life of the bridges and pavement structures. The physical condition, though not evaluated in this Study, is also very important and is evaluated regularly through MaineDOT’s bridge and pavement management systems.

C. Study Process

After the definition of a study purpose, one of the first steps in the study process was to define a study area for I-295. The I-295 Corridor Study Area extends from the toll booths at I-95 Exit 44 in Scarborough to the Exit 28 ramps in Brunswick, a distance of 28 miles. This 28-mile length was chosen because it encompasses the most heavily traveled portions of I-295: the urban mileage in South Portland and Portland, and the heavily traveled rural mileage between Portland and Brunswick. The I-295 Corridor Study Area is shown in Figure 1.1.

The study process has two major components: the technical analysis and public participation.

1. Technical Analysis

The technical analysis includes a review of existing conditions, a forecast of future conditions, and an analysis of alternatives. The review of existing conditions includes traffic volumes, physical inventory, mobility and safety performance, an inventory of I-295 and related transportation resources, and an environmental overview. The future conditions forecast encompasses future traffic volumes, mobility performance, and a review of external factors that could influence future conditions. The alternatives analysis identifies a range of potential strategies, develops these strategies into defined alternatives, measures of their effectiveness, and assesses feasibility.

2. Public Participation

The public participation component of the Study included three major elements. The first was a Corridor Advisory Committee composed of representatives from the following public entities. The purpose of the Committee was to help identify issues in the I-295 Corridor, offer potential actions, help define future performance expectations, and provide feedback on preliminary findings.

MaineDOT	FHWA	Cumberland
Maine State Police	Portland	Yarmouth
Maine Turnpike Authority	South Portland	Freeport
PACTS	Scarborough	Brunswick
GPCOG	Westbrook	
Transit Providers	Falmouth	

A total of eight Corridor Advisory Committee meetings were held between December 2003 and January 2006.

Figure 1.1: Study Area



The second component involved a series of public informational meetings held at various locations in the Study Area. The purpose of these meetings was to give members of the general public the opportunity to receive study information during the course of the study, have input on corridor issues, offer potential actions, and provide feedback on preliminary findings. Fourteen public informational meetings were held. Nine were scheduled, advertised and jointly sponsored by PACTS and MaineDOT. Five more were held at the request of the PACTS Policy Committee and municipalities in the Study Area.

PACTS/MaineDOT Sponsored	Requested
May 6, 2004 in Yarmouth	April 27, 2006 in Portland (PACTS Policy Committee)
May 13, 2004 in Portland	January 15, 2008 (Yarmouth Town Council)
August 23, 2004 in Portland	June 16, 2008 (Cumberland Town Council)
August 26, 2004 in Yarmouth	September 22, 2008 (Portland, South Portland Councils)
February 7, 2006 in Portland	October 27, 2008 (Falmouth Town Council)
February 16, 2006 in Yarmouth	
November 13, 2007 in Yarmouth	
November 20, 2007 in Brunswick	
January 30, 2008 in Portland	

The third component was an I-295 Corridor Study website to provide information about study objectives, existing and future conditions, Committee meetings, public informational meetings, transportation alternatives, and study findings. The website has also provided opportunities for public feedback by way of e-mail or by return of an I-295 questionnaire. The website has been accessible from the MaineDOT website at <http://www.maine.gov/mdot-stage/major-planning-studies/i295corridorstudy/index.php>.

II. Existing Conditions

The analysis of existing conditions provides a detailed description of the current geometric and operating characteristics of the I-295 Corridor. This analysis requires the development of a comprehensive inventory of existing conditions in terms of traffic volume and composition, level of service, roadway geometry and crash history. It also serves as a benchmark for analyzing future conditions and comparing potential improvement alternatives. An important product of the existing conditions analysis is the identification of geometric and operational deficiencies in the I-295 Corridor that adversely affect its ability to serve safely and efficiently. Also important are the identification of other parts of the regional and local transportation systems that interact with the I-295 Corridor and the overview of the environmental conditions along the I-295 Corridor.

A. Traffic Volumes

Two permanent traffic counting stations are located on I-295: one in South Portland (between Exit 3 and Exit 4) and the other in Cumberland (north of Tuttle Road). They provided data for an analysis of I-295 traffic flow variation. Monthly, daily, and hourly variations in traffic flow on I-295 at these two locations are shown in the following figures.

The existing conditions traffic volumes for most locations in the I-295 Corridor were based on counts from 2002, the year with the most complete set of Corridor traffic counts available for the Study. Comparison of 2002 data with the limited amount of traffic count data since then indicates that 2002 remains a useful base year for the purpose of this Study.

1. Monthly Variation

Figure 2.1 and Figure 2.2, South Portland and Cumberland respectively, show the monthly variation in the average daily traffic for the year 2002. The Annual Average Daily Traffic (AADT) is 77,900 in S. Portland and 56,160 in Cumberland. The AADT is the total annual traffic volume divided by the number of days in the year. The peak months for both locations are in July and August. The low month for S. Portland is February, and for Cumberland it is January. Monthly traffic volumes are relatively consistent throughout the year in S. Portland ranging from 70,200 (90 % of AADT) in February to a high of 86,500 (111 % of AADT) in August. This is a typical pattern in an urban area. There is more monthly variation at the Cumberland site, where traffic volumes range from 46,100 (82 % of AADT) in January to a high of 69,700 (124 % of AADT) in August. Although the volumes are lower in Cumberland than at the South Portland site; summer tourism has a stronger influence. In general, monthly variations tend to have greater fluctuation on rural routes than on urban routes.

Figure 2.1: South Portland Monthly Traffic Variation

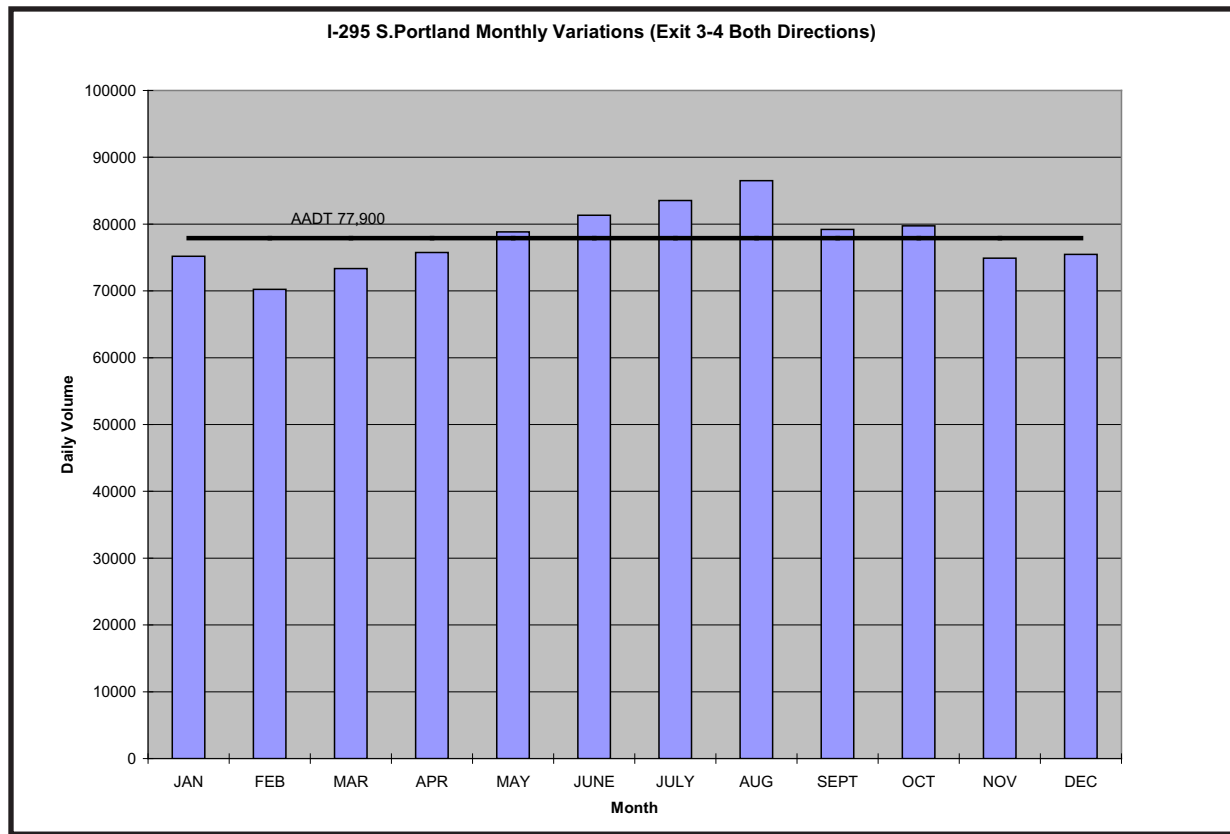
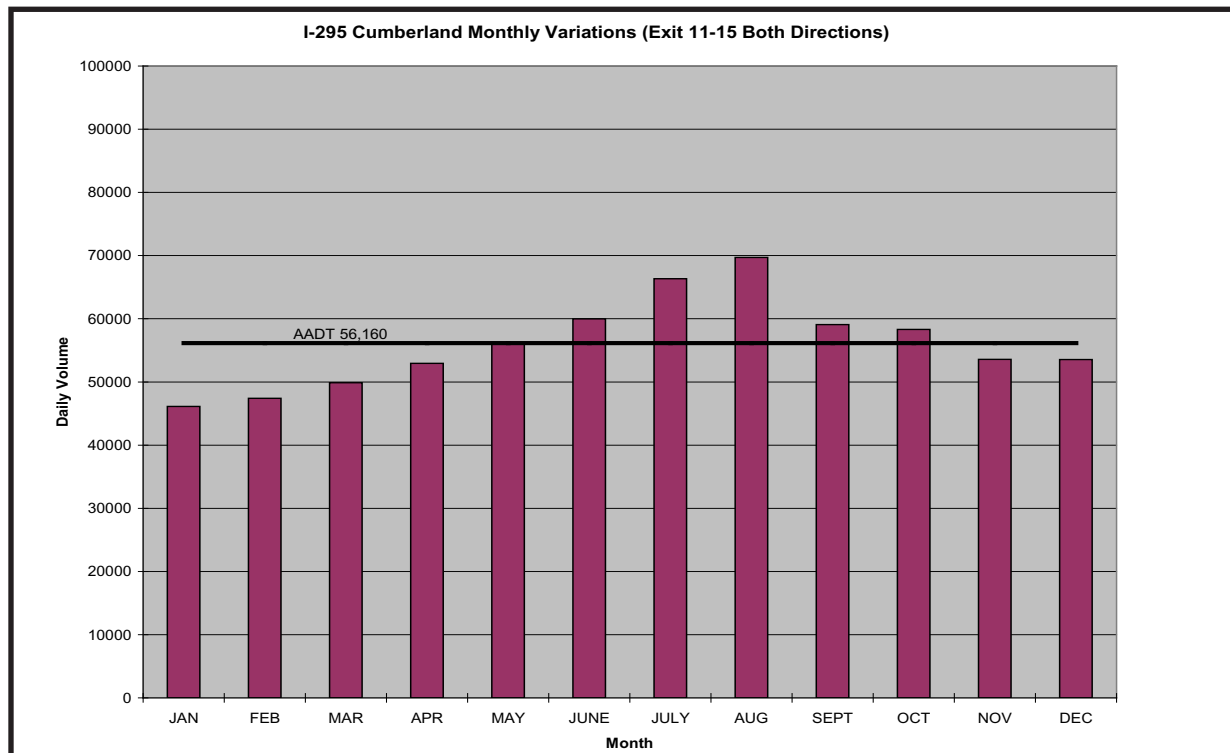

Figure 2.2: Cumberland Monthly Traffic Variation



2. Daily Variation

Figures 2.3 and 2.4 show the average daily variation for July and August traffic volumes expressed as a percent of the average daily traffic volume. The highest day of the week in both figures is Friday and the lowest two are Saturday and Sunday. The Cumberland site data shows less daily variation in traffic over the course of the week than the South Portland site, which has a greater reduction on the weekend. At the Cumberland site, the tourism traffic on weekends comes closer to offsetting the reduced commuter traffic.

Figure 2.3: South Portland Daily Traffic Variation

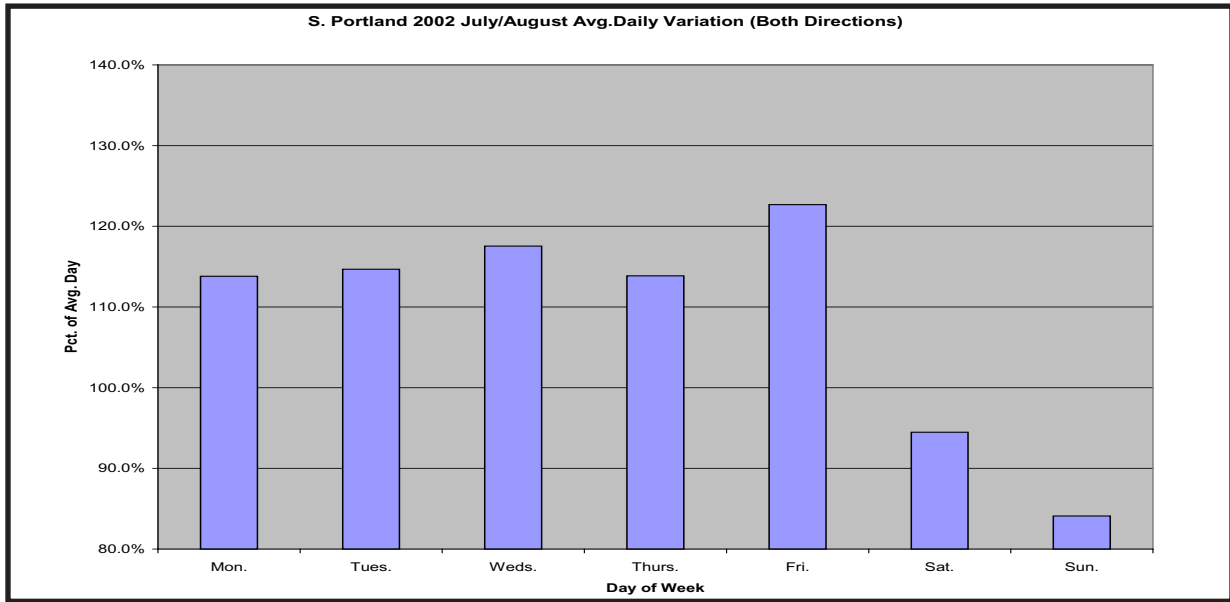
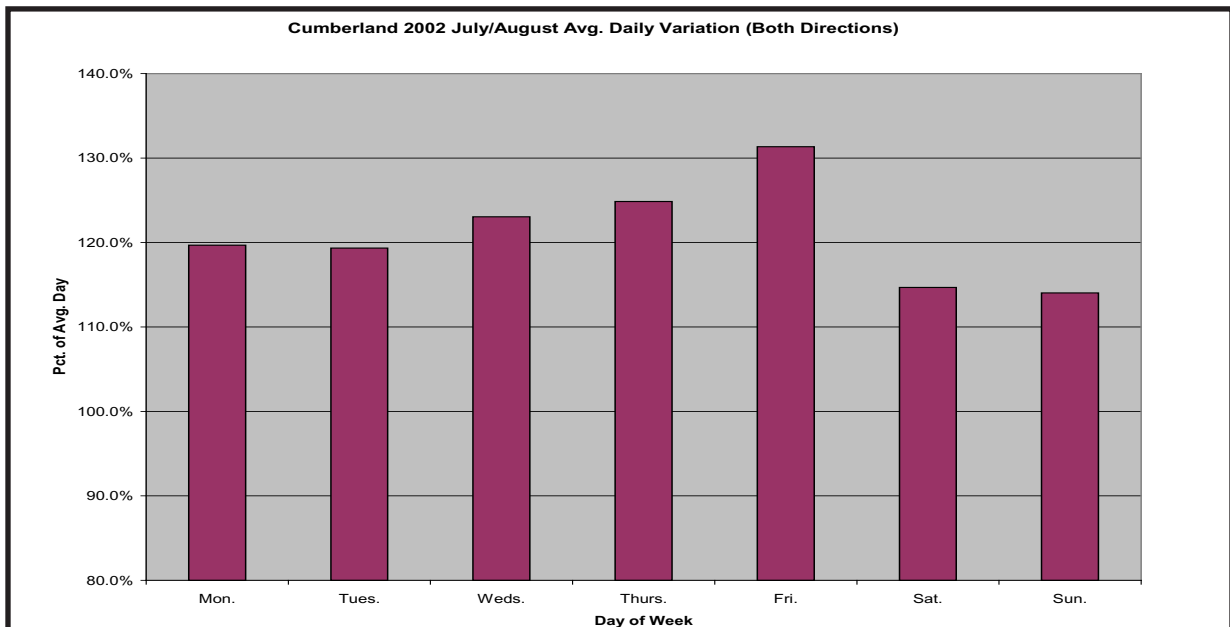

Figure 2.4: Cumberland Daily Traffic Variation



3. Daily Traffic Flows

Figure 2.5 and Figure 2.6 show the 2002 annual average daily traffic (AADT) for the Study Area. The northbound AADT volumes are depicted in the yellow boxes between interchanges and the southbound AADT volumes are shown in the gray boxes.

As shown in Figure 2.5 and Figure 2.6, volumes within the Study Area vary from a low of 20,200 (7,750 northbound and 12,380 southbound) vehicles per day north of I-95 Exit 44 in Scarborough to a high of 84,100 (43,320 northbound and 41,750 southbound) vehicles per day on Tukey's Bridge in Portland. From south to north along the corridor the AADT increases from 20,200 north of I-95 Exit 44 to 77,900 between Exit 3 and Exit 4 in South Portland. The AADT drops to 69,200 over the Fore River, and then it increases to 71,200 between Exit 7 and Exit 8 in Portland. The AADT reaches its maximum of 84,100 at Tukey's Bridge. Between Exit 8 and Exit 9 the traffic drops to 62,100 and then it drops again after Exit 9 to 47,500 and then to 45,700 between Exit 10 and Exit 11 in Falmouth. The traffic increases again north of the Falmouth Spur (Exit 11) to 55,700 and then drops between Exit 15 and Exit 17 to 46,900 in Yarmouth. The traffic volume increases again between Exit 17 and Exit 20 to 50,400 and drops to 44,600 between Exit 24 and Exit 28.

Figure 2.5: South Portland-Portland Directional AADT



Figure 2.6: Portland-Brunswick Directional AADT

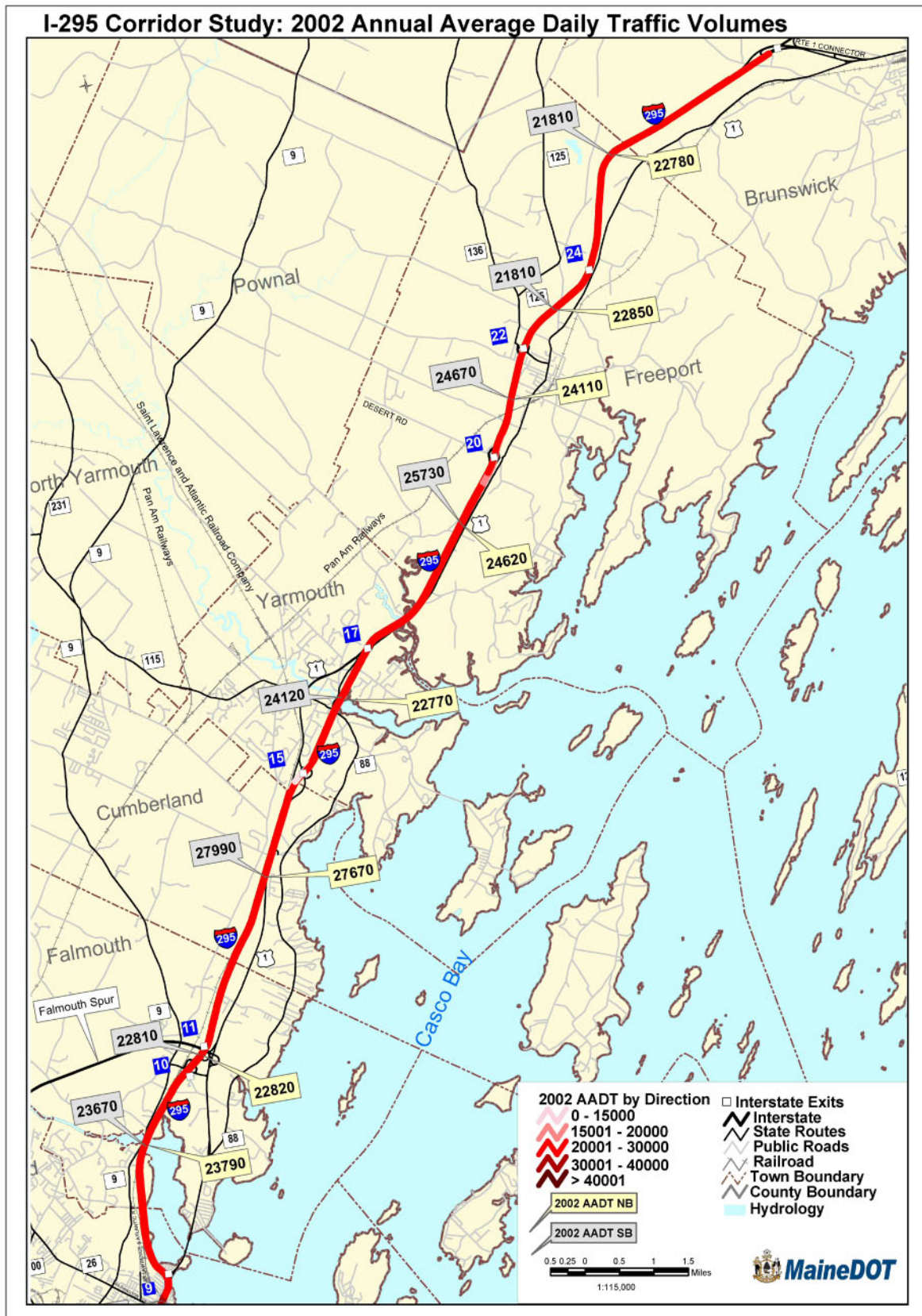

4. Hourly Traffic Flows

Figures 2.7 and 2.8 show the combined northbound and southbound average hourly variation in the months of July and August, in South Portland and in Cumberland respectively. The peak hour at both sites is from 4 PM to 5 PM and the lowest is between 2 AM and 3 AM. For South Portland there are two pronounced peaks between 7 AM and 6 PM; the Cumberland site is more consistent between these hours, largely because of the influence of tourism traffic, which is not oriented to peak commuting hours.

Figure 2.7: South Portland-Summer Hourly Variations

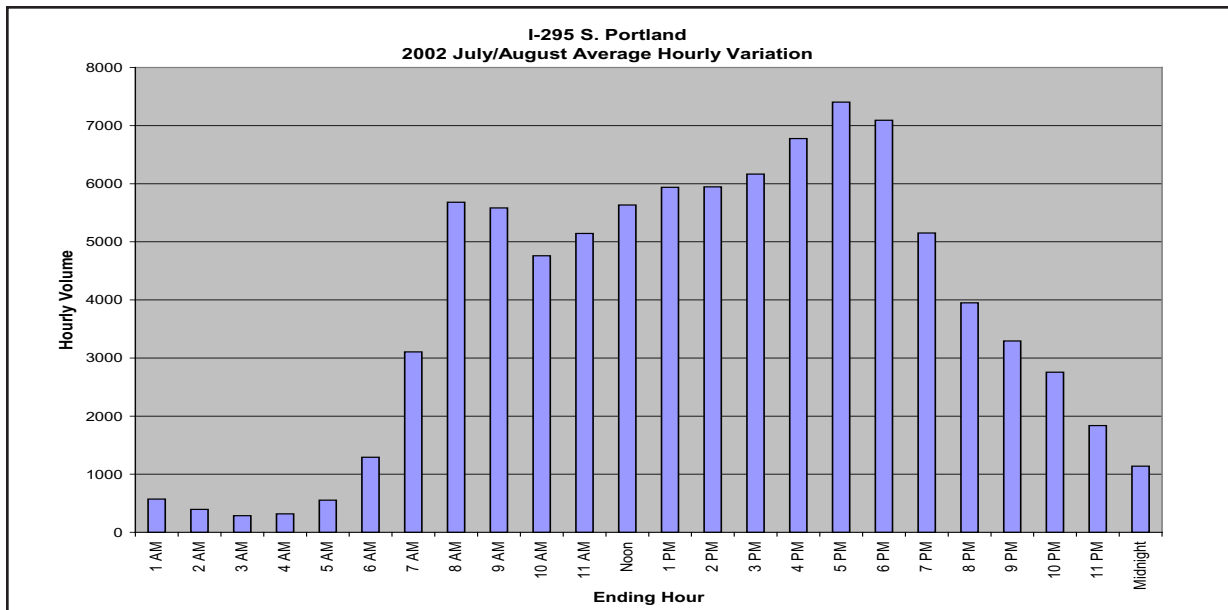
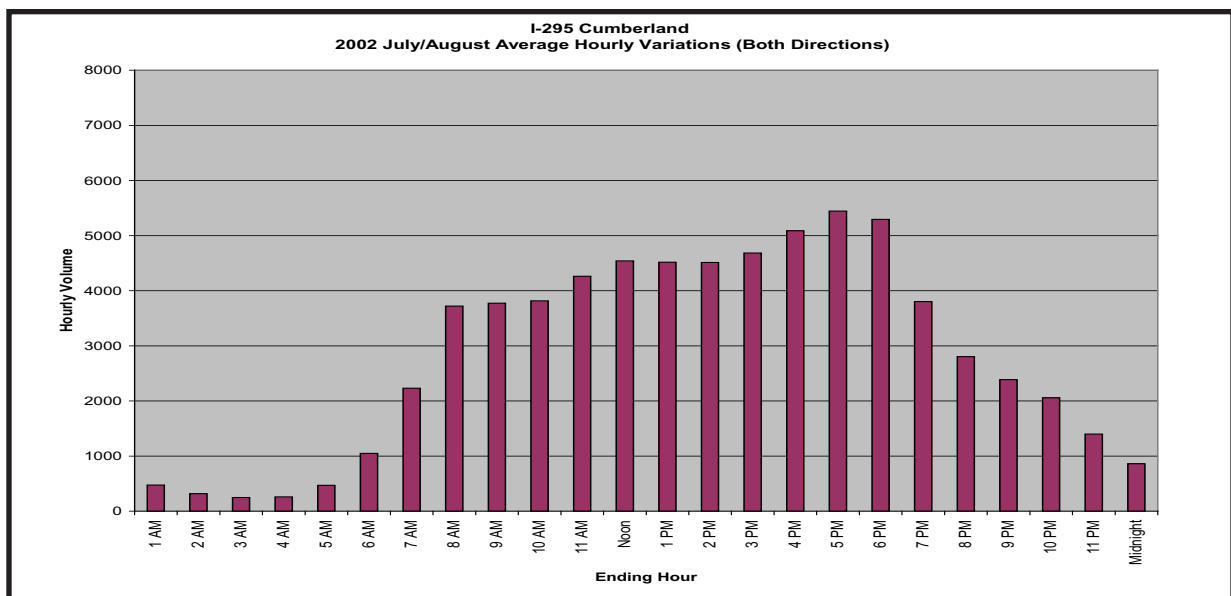

Figure 2.8: Cumberland-Hourly Variations



5. Directional Hourly Traffic Variation

Figures 2.9 and 2.10 show the hourly variations of I-295 traffic volume by hours of the day on Tuesday, August 13, 2003, for South Portland and Cumberland respectively. Both figures show an AM and PM peak, the AM peak is northbound in South Portland and southbound in Cumberland. This pattern would be expected as many people head into Portland to work.

Figure 2.10 shows a typical weekday distribution for commuter traffic on a rural highway. Peak periods of travel occur in the morning during the hour from 7 to 8 AM, and in the afternoon between the hours of 4 and 6 PM. During the morning peak, the directional distribution is greater (over 64%) in the southbound direction toward Portland. During the afternoon peak, the directional distribution is greater (60%) in the northbound direction. During the noon hours the directional distribution is around 50 % in each direction. Although the directional distribution is greater in the morning, the peak traffic (over 6000 vehicles per hour) occurs in the afternoon over a longer time period. After 6 PM, the volumes decrease and reach a low of less than 200 vehicles per hour from 2 to 3 AM.

The South Portland site also has the AM and PM peaks like Cumberland but the traffic is more evenly distributed between northbound and southbound. The more even directional distribution in South Portland, especially during the mid-day hours, is likely due to the local travel activity of workers in Portland and South Portland.

Figure 2.9: South Portland-Hourly Variation

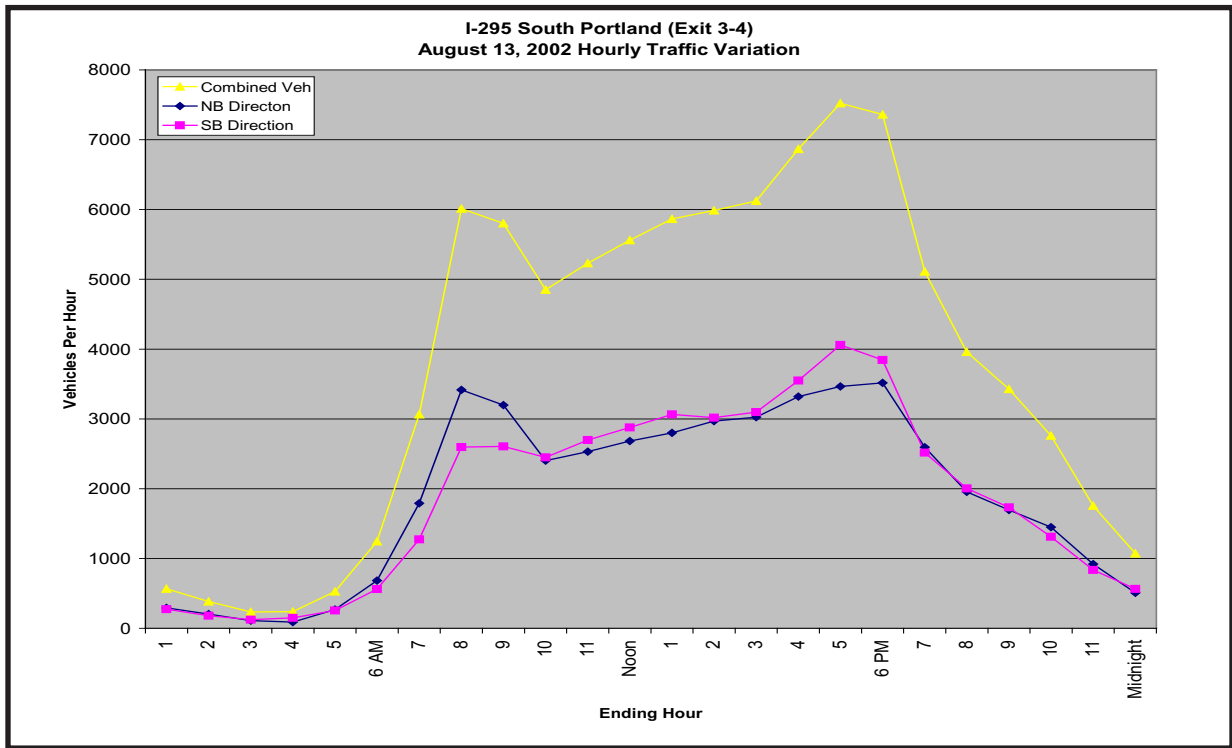
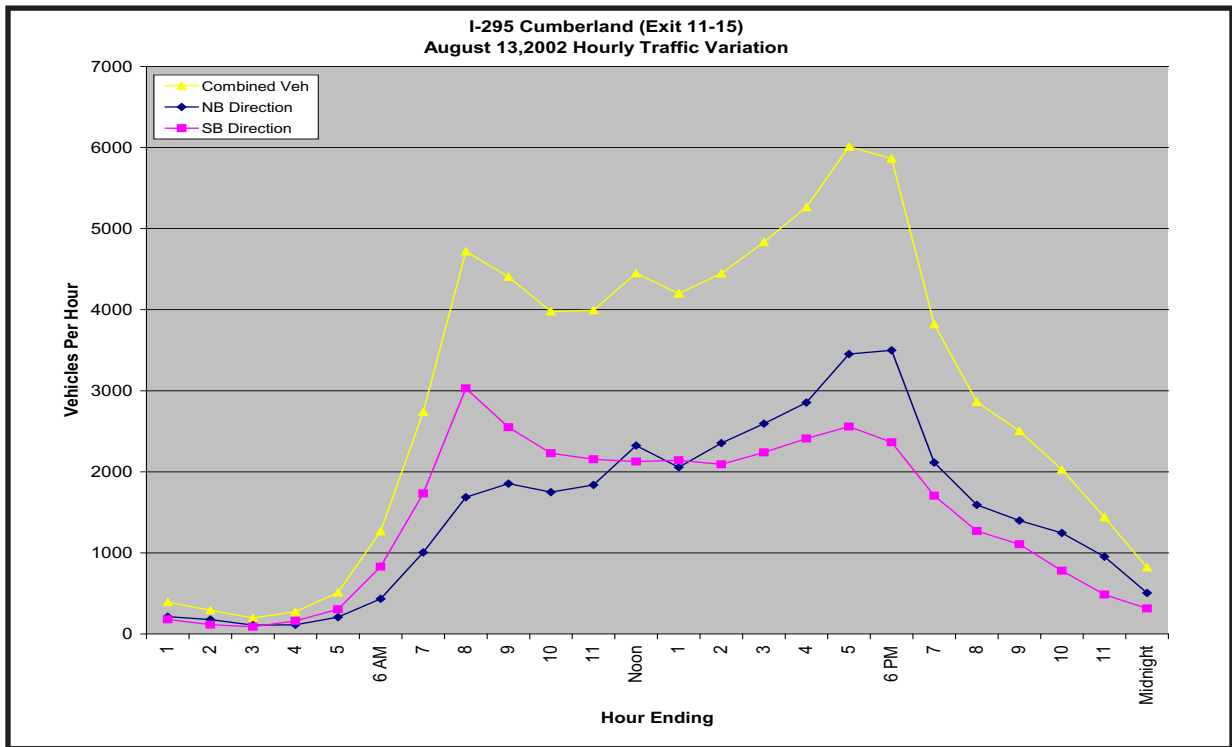

Figure 2.10: Cumberland-Hourly Variation



6. Design Hour Volume

The design policy of the American Association of State Highways and Transportation Officials (AASHTO) recognizes that “Economic considerations in the planning and design of highways make it impractical to design for the highest expected hourly volumes”. Instead, a design hour volume (DHV) is based on the 30th highest hour of the year. The existing DHVs were developed from the permanent counting stations on I-295 in South Portland, Cumberland and north of Route 1 in Brunswick and supplemented by 24-hour traffic counts (Monday afternoon through Friday morning) for the last two weeks in October along the corridor. Because I-295 is a freeway, a divided highway with access available only at grade separated interchanges, DHVs were determined for both northbound and southbound directions. Given the distinct AM and PM peaks in hourly traffic flow, AM and PM DHVs were analyzed. AM peak-hour volumes in October, from 7 to 8 AM, are representative of the 30th highest hour for the AM. In October, the AM peak hour is heavily influenced by trips to work and school. PM peak-hour volumes in August, from 4 to 5 PM, are representative of 30th highest hour for the PM. In August and other summer months, the PM peak hour is influenced by seasonal recreational trips. Although most traffic counts in the I-295 Corridor were collected in October, year-round count information in Cumberland and South Portland enabled PM peak-hour counts to be adjusted to August levels to obtain PM DHVs. The AM and PM 2002 DHVs are located in Appendix 2.

7. Historical Traffic Growth

Figures 2.11 and 2.12 show the historical growth in traffic over the past years in South Portland and in Cumberland. The historical data indicates that traffic continues to grow in the corridor study area. Based on the review of data from 1981 to 2002, the annual growth in AADT has averaged about 2.7 percent per year, or approximately 2,100 vehicles per year, in South Portland and 3 percent per year, or approximately 1,650 per year, in Cumberland.

In the years since 2002, for which comparable data is available, the AADT at the South Portland and Cumberland locations has been nearly constant or even decreased in the short term, as shown in the dashed lines. Periods of slow increases or decreases have occurred in the past due to economic slowdowns, energy shortages, or sharp increases in energy costs.

Figure 2.11: South Portland-Historical Traffic Growth

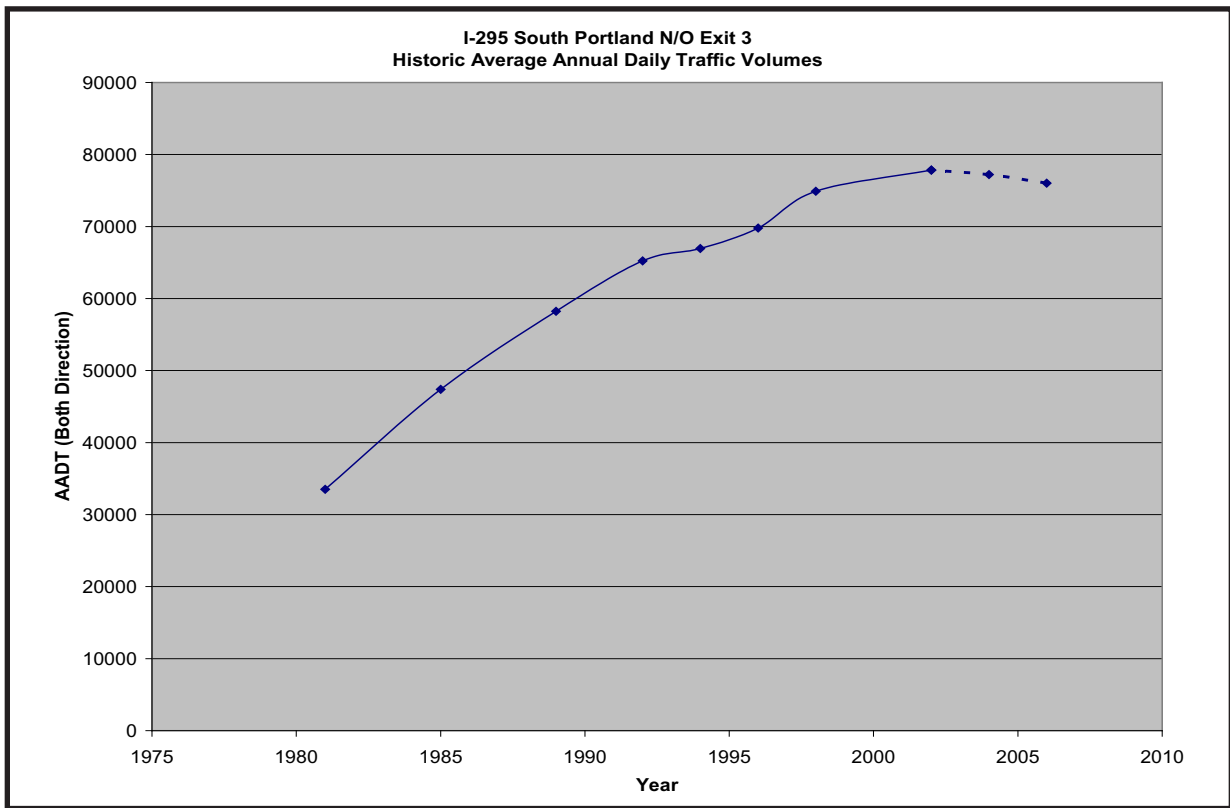
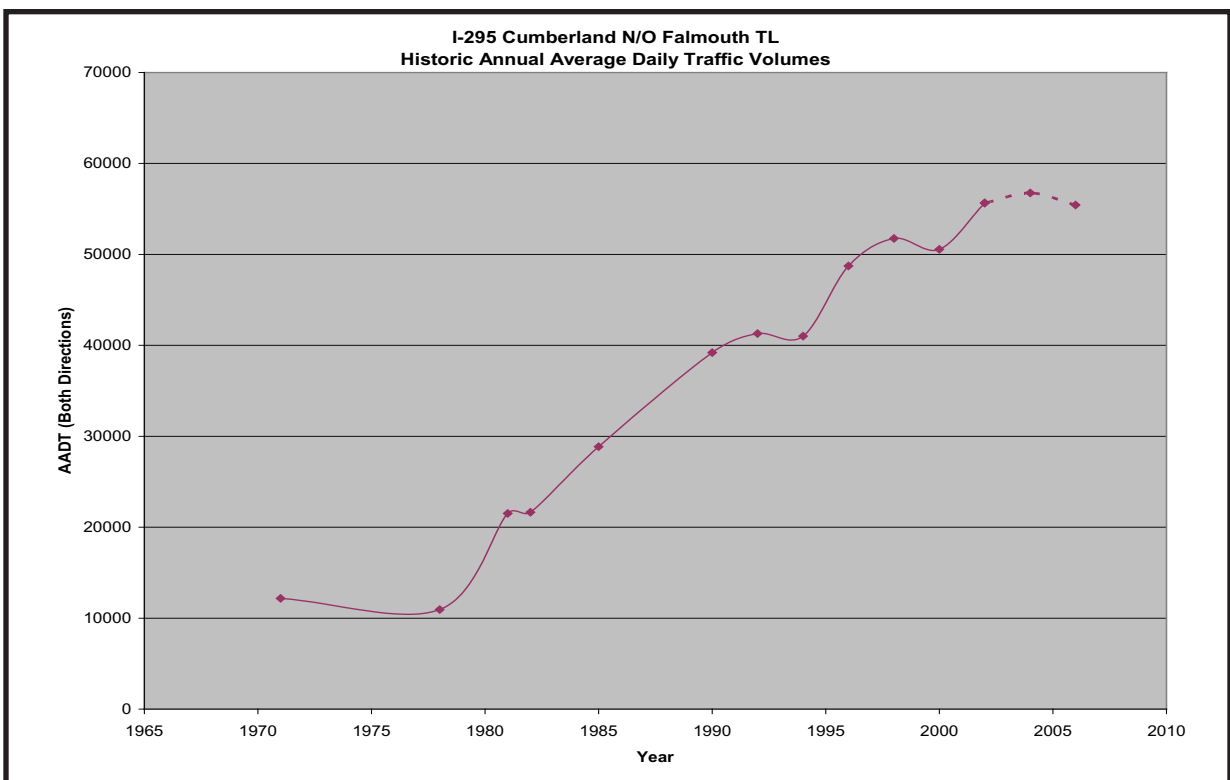

Figure 2.12: Cumberland-Historical Traffic Growth



B. Existing Conditions Inventory

The existing conditions inventory for the I-295 Corridor Study consists of readily available baseline information about roadway geometry of the highway, the recent safety record of the highway, and the recent history of reported highway incidents.

1. Roadway Geometry

The existing roadway geometry of the Corridor helps to define the potential and the limitations of the existing roadway. The spacing of interchanges, number of lanes, lane and shoulder widths, curvature, and ramp characteristics that went into the design and construction of the facility all affect the capacity of the roadway and the safe speed of operation.

The I-295 Corridor Study Area is approximately 28 miles, from Scarborough to Brunswick. Table 2.1 lists the more notable roadway construction projects in the history of I-295. I-295 was constructed from the late 1950s (beginning with a bypass around Freeport) to the late 1980s (Tukey's Bridge and the Yarmouth/Freeport area). Throughout the corridor, the freeway has two through-lanes in both the northbound and southbound directions. The median width (edge of travel lane to opposite edge of travel lane) varies throughout the corridor. The median from Exit 1 to Exit 7 is 40 feet. The median narrows from Exit 8 to just past Exit 9 to 14 feet and as narrow as 9 feet. From just north of Exit 9 to Exit 17 the median is typically 36 feet in width (the section between Exit 9 and Presumpscot River has some sections as wide as 100 feet). The median between Exit 17 and Exit 20 varies from 36 feet to 66 feet (last built roadway section). From Exit 20 to Exit 28 (older sections) the median is 26 feet in width. Although the median width is narrow in this section, in many places there is a vertical grade difference between the northbound and southbound direction.

Table 2.2 (urban) and Table 2.3 (rural) shows existing information about the interchanges and the ramps. In the urban area, there are currently nine weaving segments. According to the Highway Capacity Manual, a weaving segment is the length of highway, formed by merge and diverge points, over which traffic streams cross paths through lane change maneuvers, without the aid of traffic signals. The weaving configuration has a major impact on the number of lane changes required for each weave. Figure 2.13 shows three types of weaving configurations; Type A, Type B and Type C. Type A is the most common where all the weaving vehicles must make one lane change. An example of this is at Exit 6 between Forest Avenue on-ramp and Forest Avenue off-ramp. Type B is the most efficient, where one weaving movement can be made without making a lane change and the other movement requires at most one lane change. An example of this is NB on I-295 between Baxter Boulevard on-ramp and Exit 9 off-ramp to Martin's Point. Type C are similar to Type B however one weaving maneuver requires no lane change and the other at least two or more lane changes. An example of this is NB on I-295 if coming from Washington Avenue on-ramp and going north on I-295 NB to Falmouth and beyond.

Table 2.1: Historical Roadway Construction Projects

Project Number	Location		Const. Date	Median Width (Ft)	Travel Width (Ft)	Shoulder Width (Ft)	Length (Miles)
	From	To					
I-295-3(58)44	MTA	Exit 1	1973	40	12	10	1.456
I-295-3(47)45	Exit 1	Exit 4	1973	40	12	10	1.723
I-295-3(76)47	Exit 4	Exit 8	1974	40	12	10	3.678
IR-295-3(100)50	Exit 8 (Tukey's Area)	Exit 8 (Tukey's Area)	1985	14	12	10	0.350
I-295-3(95)50	Exit 8 (Tukey's Area)	Exit 8 (Tukey's Area)	1985	14	12	12	0.269
IR-295-3(99)50	Exit 8 (Tukey's Area)	Exit 9	1985	14	12	8	0.090
IR-295-3(102)50	Exit 8	Exit 9	1985	14	12	8	0.071
I-295-3(2)51	Exit 9	Exit 9	1960	9	12	10	0.426
I-295-3(3)51	Exit 9	Presumpscot River	1960	9-100	12	10	2.141
I-295-3(5)54	Presumpscot River	Exit 10	1960	36	12	10	0.984
I-295-3(6)55	Exit 10	Exit 11	1960	36	12	10	0.284
I-95-4(4)55	Exit 11	Exit 11	1961	36	12	10	0.379
I-95-4(7)	Exit 11	0.4 mi. s/o Tuttle Rd	1959	36	12	10	2.330
I-95-4(8)58	0.4 mi. s/o Tuttle Rd	Exit 15	1960	36	12	10	1.701
I-95-4(9)59	Exit 15	Royal River	1960	36	12	10	1.135
I-95-4(10)60	Royal River	Exit 17	1961	36	12	10	1.250
I-IR-95-4(44)	Exit 17	Exit 20	1987	36-66	12	10	3.004
IN-95-4(2)	Exit 20	Exit 24	1957	26	12	10	2.801
I(52)IN-95-4(1)	Exit 24	Exit 28	1959	26	12	10	5.435
I-95-4(25)73	Exit 28	River Rd	1970	Variable	12	10	1.411
IR-95-4(61)72	Exit 28 SB Off-Ramp	Exit 28 SB Off-Ramp	1990	n/a			1.080

Table 2.2: Urban Interchanges

Int. No.	Town	Cross Road	Type	Dir.	On/Off	Accel. (Ft)	Decel. (Ft)	Weave (Ft)	Weave Type
1	South Portland	Rte. 703	Partial Cloverleaf	NB	Off		360		
				NB	On	800			
				SB	Off		325		
2	South Portland	Scarborough Connector	Partial Direct	NB	On	1600			
				SB	Off		1350		
3	South Portland	Westbrook Street	Half Diamond	NB	On	700			
				SB	Off		350		
4	South Portland	Rte. 1 Veterans Bridge	Partial Direct	NB	Off		175		
				NB	ON	500			
				SB	Off		325		
				SB	On	225			
5	Portland	Congress Street	Modified Diamond	NB	Off		300		
				NB	On	500			
				NB	On	300			
				SB	Off		950		
				SB	On			725	A
				SB	Off				
6	Portland	Forest Avenue	Cloverleaf	NB	Off		450		
				NB	On			500	A
				NB	Off				
				NB	On			700	A*
				SB	Off		350		
				SB	On			400	A
				SB	Off				
7	Portland	Franklin Arterial	Trumpet	NB	Off			700	A*
				NB	On			1900	A
				SB	Off		300		
				SB	On	350			
8	Portland	Washington Avenue	Overlap	NB	On			1000	C
				NB	Off				
				SB	On			1200	B
				SB	Off				
9	Portland	Rte. 1 Martin's Point	Overlap	NB	On			700	B
				NB	Off				
				SB	On			1000	A
				SB	Off				

*Shared weaving segment between the Exit 6 NB on-ramp and the Exit 7 NB off-ramp.

Table 2.3: Rural Interchanges

Int. No.	Town	Cross Road	Type	Dir.	On/Off	Accel. (Ft)	Decel. (Ft)	Weave (Ft)	Weave Type
10	Falmouth	Bucknam Road	Partial Cloverleaf	NB	Off		325		
				NB	On	350			
				SB	Off		300		
				SB	On	800			
11	Falmouth	Falmouth Spur	Half Trumpet	NB	On	300			
				SB	Off		300		
15	Yarmouth	Rte. 1	3/4 Modified Diamond	NB	Off		275		
				SB	Off		325		
				SB	On	300			
17	Yarmouth	Rte. 1	Diamond	NB	Off		275		
				NB	On	350			
				SB	Off		250		
				SB	On	350			
20	Freeport	Desert Road	Diamond	NB	Off		350		
				NB	On	375			
				SB	Off		450		
				SB	On	375			
22	Freeport	Rte. 125/136	Partial Cloverleaf	NB	Off		375		
				NB	On	525			
				SB	Off		500		
				SB	On	325			
24	Freeport	Rte. 1	Half Trumpet	NB	Off		250		
				NB	On	300			
28	Brunswick	Rte. 1	Trumpet	NB	Off		1200		
				NB	On	800			
				SB	Off		375		
				SB	On	2400			

Table 2.2 and also Table 2.3 show the acceleration and deceleration lengths as measured for highway capacity analysis. The length of the acceleration and deceleration lane has a significant effect on merging and diverging operations. Short lanes provide on-ramp vehicles with restricted opportunity to accelerate before merging and off-ramp vehicles with less opportunity to decelerate off-line. The result is that most acceleration and deceleration must take place on the mainline, which disrupts through vehicles. Short acceleration lanes also force many vehicles to slow significantly and even stop while seeking an appropriate gap in the Lane 1 traffic stream. Many of the older on and off ramps in the rural area are too short for today's standards and were not designed for current day ramp volume.

Figure 2.13: Weaving Type Configurations

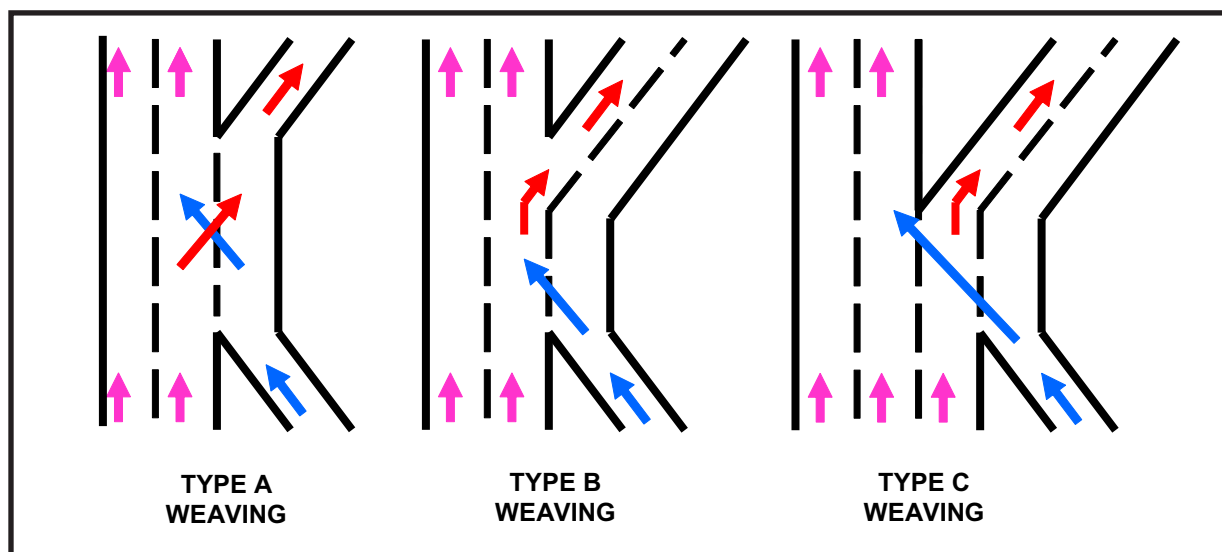

2. Highway Safety

Crash data for the years 2000 through 2002 were used to identify High Crash Locations (HCLs) in the Study Area. A HCL is a highway location that has eight (8) or more traffic crashes and a Critical Rate Factor (CRF) greater than 1.00 in a three-year period. A location with a CRF greater than 1.00 has a frequency of crashes that is greater than the statewide average for similar locations. Locations in the I-295 Study Area were thoroughly researched to refine the HCL information.

Based on the results of the crash research, fourteen locations within the Study Area meet the criteria for placement on MaineDOT's list of High Crash Locations (HCLs). Collision Diagrams were prepared for these locations to determine if there are any crash patterns or trends evident that may indicate correctable roadway/intersection deficiencies. These diagrams are provided in Appendix 1. Table 2.4 summarizes the high crash location, the number of crashes, injury type and the CRF for the Study Area intersections and road segments. Figures 2.14 and 2.15 show the HCL locations.

In a review of overall crash experience since the 2000-02 time period, crash summary data from 2005-07 was compared with similar information from 2000-02. The overall crash rate for the Study Area has remained 68.4 crashes per hundred million vehicle-miles for both time periods. A change in the percentage of injury crashes from 29% in 2000-02 to 31% in 2005-07 suggests that monitoring of overall crash experience on I-295 is important for identifying emerging safety trends in the Corridor.

Table 2.4: High Crash Locations

Location	Total Crash	Injury Type					Percent Injury	CRF
		K	A	B	C	PD		
S. Portland- Exit 3 On-Ramp @ Westbrook St.	14	0	1	0	3	11	28.6	1.58
S. Portland – SB Mainline Exit 4 to Exit 3	30	0	2	4	6	18	40.0	1.25
Portland –Exit 5 NB Off-Ramp @ Congress St.	33	0	0	3	8	22	33.3	4.26
Portland –Exit 6B NB Off-Ramp @ Forest Ave.	50	0	0	4	11	35	30.0	3.00
Portland –Exit 6B SB Off-Ramp @ Forest Ave.	21	0	0	3	5	13	38.1	1.23
Portland –Exit 6A SB Off-Ramp @ Forest Ave.	63	0	0	7	22	33	46.0	3.77
Portland –Exit 7 NB Off-Ramp @ Franklin Art.	11	0	0	0	0	11	0.0	1.0
Falmouth –Exit 10 NB Off-Ramp @ Bucknam Rd.	22	0	0	4	2	16	27.3	3.98
Falmouth –Exit 10 SB Off-Ramp @ Bucknam Rd.	8	0	0	1	4	3	62.5	1.49
Yarmouth – Exit 15 SB On-Ramp @ I-295 SB	9	0	0	0	5	3	62.5	2.17
Yarmouth – Exit 17 NB Off-Ramp @ Rte. 1	8	0	0	0	2	6	25.0	1.20
Freeport – SB Mainline Exit 20 On-Ramp to Crossover (0.20 mi.)	8	0	1	1	0	6	25.0	1.03
Freeport – Exit 20 NB Off-Ramp @ Desert Rd.	9	0	0	0	1	8	11.1	1.51
Freeport – Exit 22 NB Off-Ramp @ Mallett Dr.	25	0	0	0	9	16	36.0	4.43

Note: Injury Type: K=fatality A=incapacitating B=non-incapacitating C=possible injury
 PD=no injuries (property damage)

Figure 2.14: Urban High Crash Locations

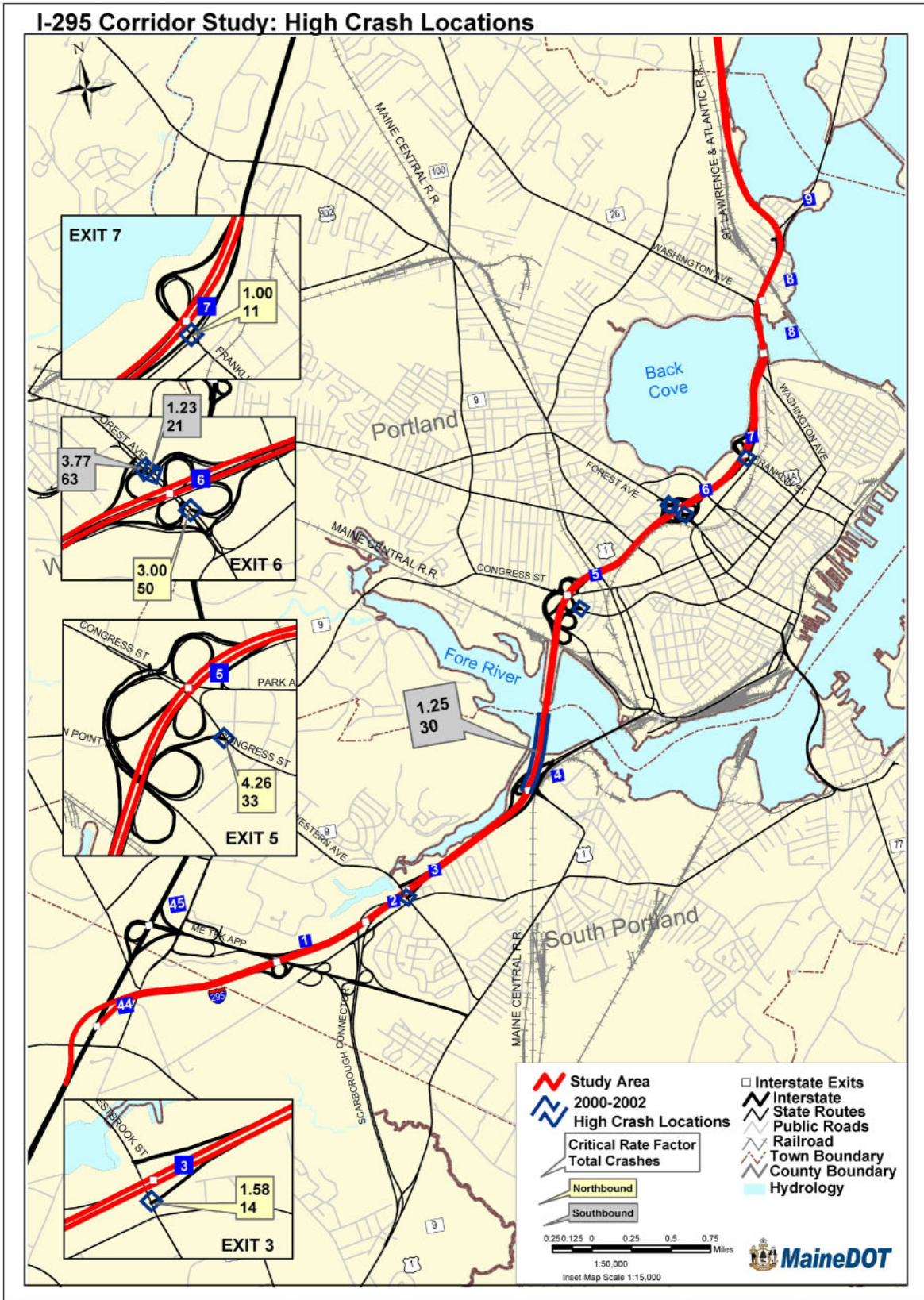
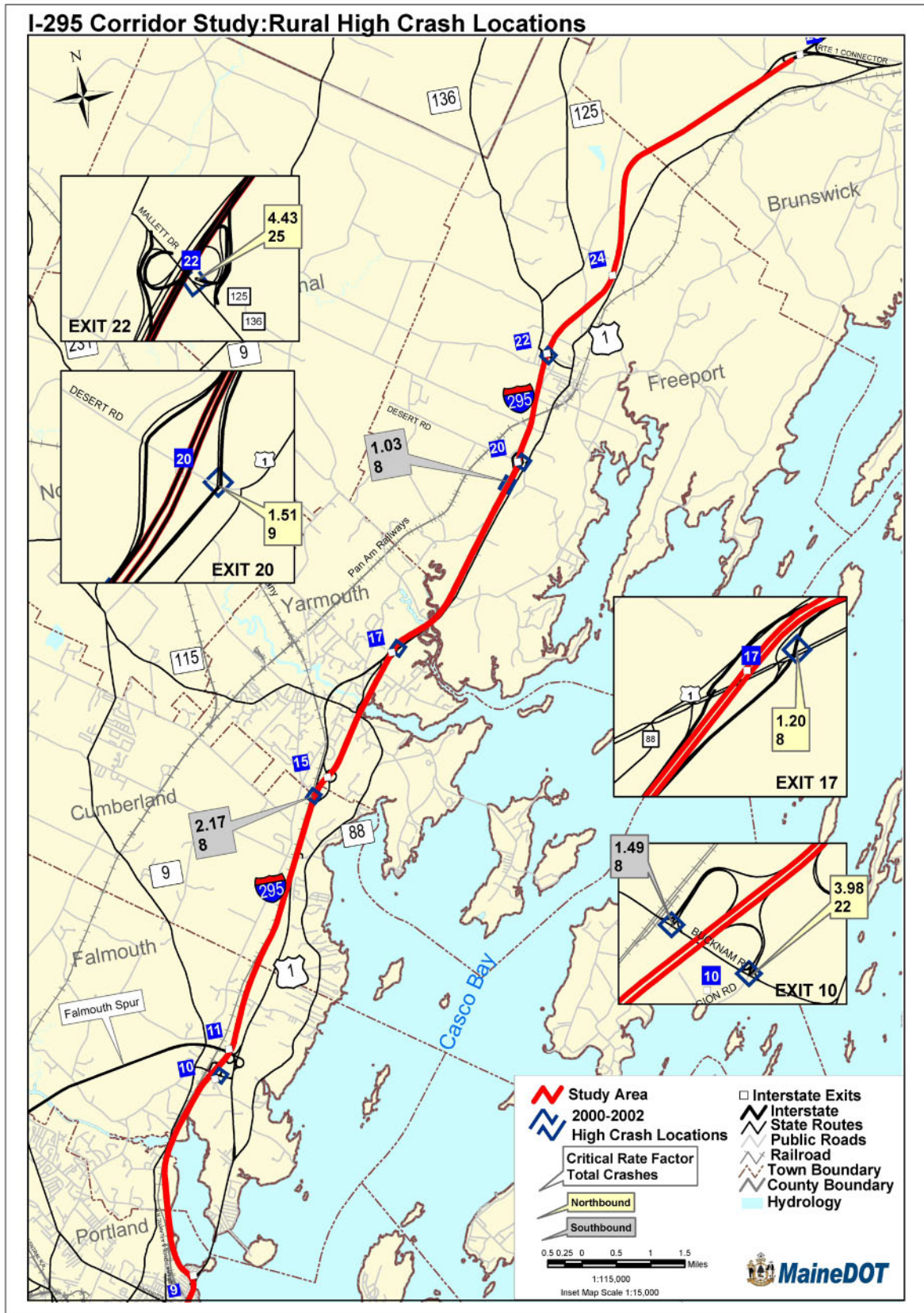

Figure 2.15: Rural High Crash Locations



3. Highway Incidents

Along with the reportable crash data, the Maine DOT received incident data from the Maine State Police. Incidents are defined as crashes, breakdowns, and other random events that occur on the highway. According to Oregon Department of Transportation Research Report PSU-CU-TRG-01-01 (June 30, 2001), incidents contribute to approximately 50 percent of the congestion delay on the nation's highways, lead to major road closures, and adversely affect the safety of the transportation network. Incidents increase drivers' exposure to hazardous conditions and are known to lead to secondary crashes.

The Maine State Police reporting system includes details regarding the incident type, location, time of occurrence, and time of resolution. During the period from November 2003 to October 2004 there were a total of 3,815 incidents reported to the State Police in the study area. Of that number, 2,234 were of a type that could cause delay. Figure 2.16 pie chart shows that largest percentage is Aid to Motorist (40%) followed by Traffic Accidents (32%) and Road Hazard (9%).

Figure 2.16: Incident Types

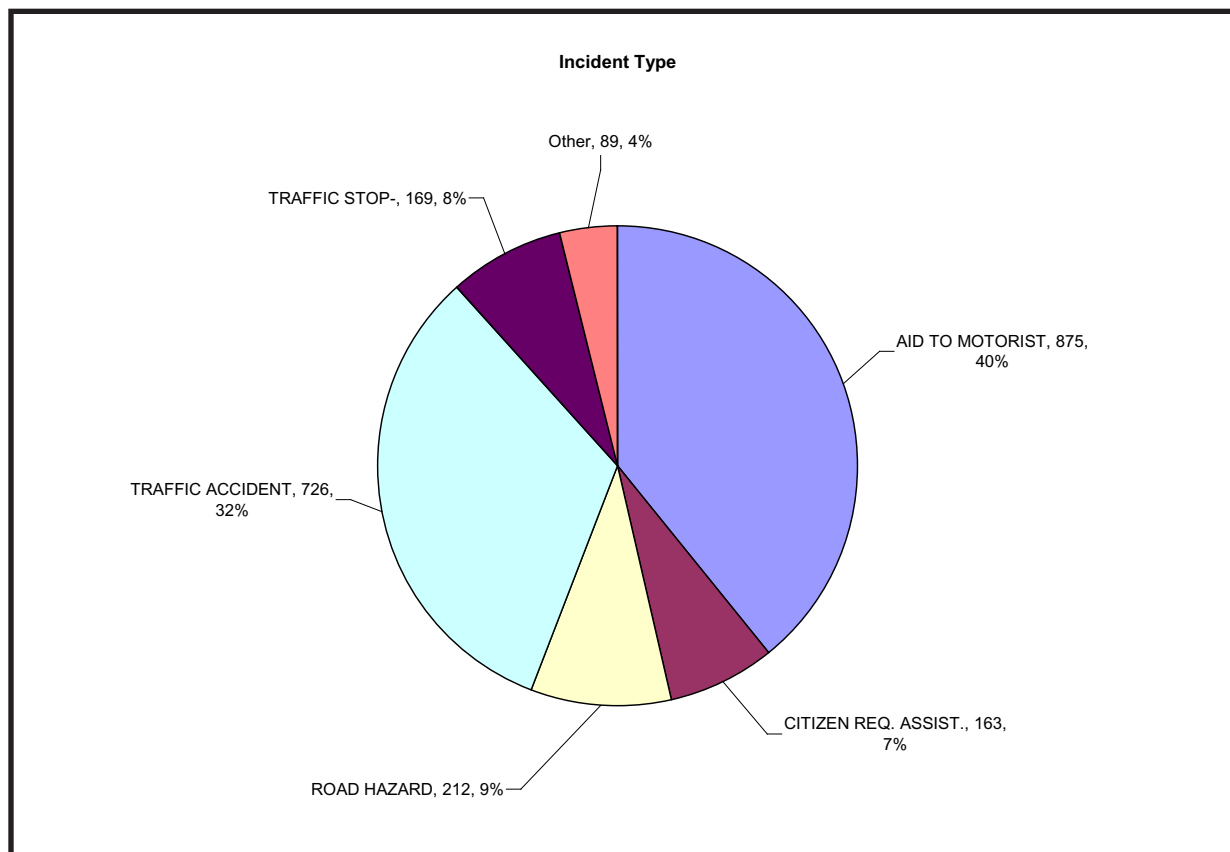

Figure 2.17 shows the monthly incident variation along the study area for both northbound and southbound directions. The highest month during this one year period occurred in December (249) and the lowest month was in November (142).

Figure 2.17: Monthly Incident Variation

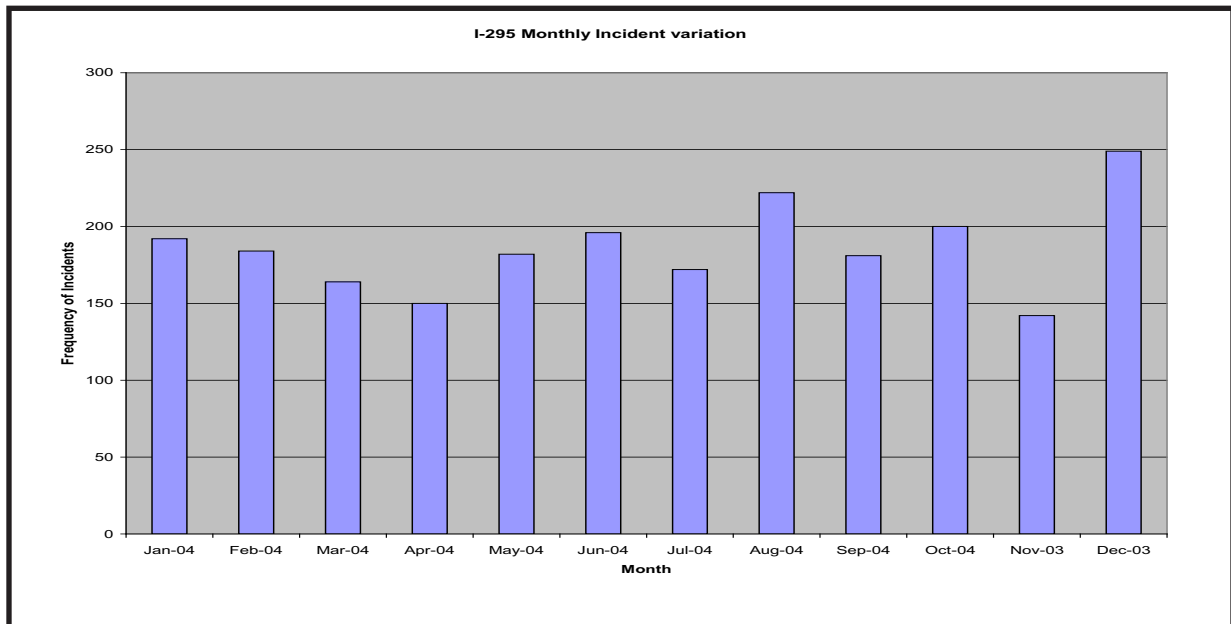

Figure 2.18 shows the daily incident variation along the study area for both northbound and southbound directions. The number of incidents is relatively consistent throughout the week with highest day on Friday (343) and the lowest day on Tuesday (281).

Figure 2.18: Daily Incident Variation

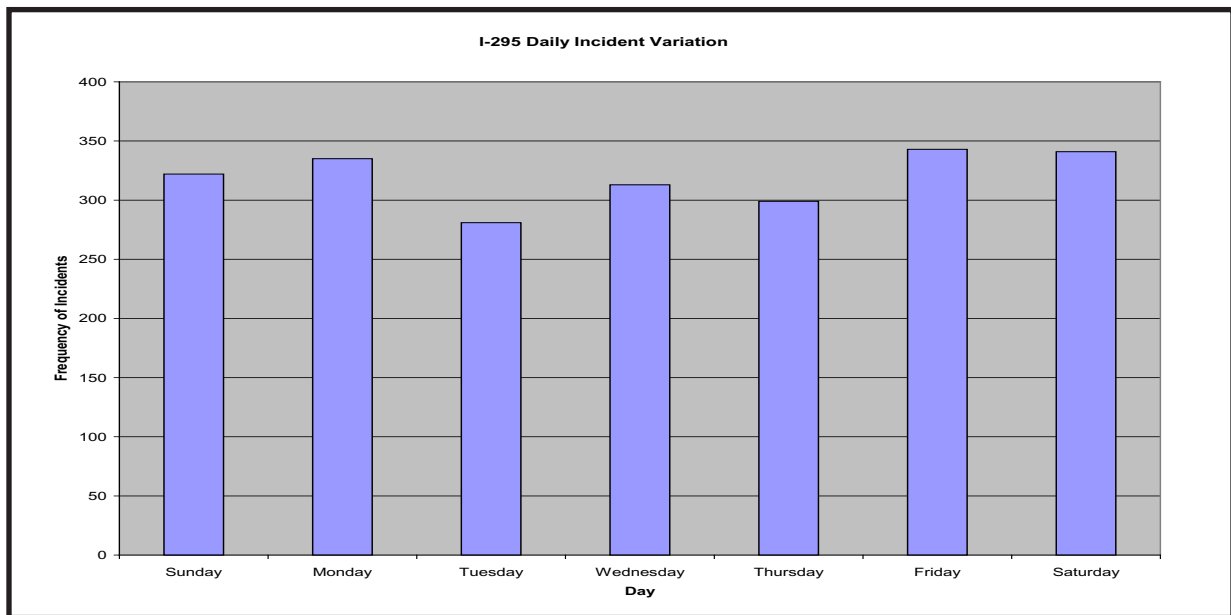
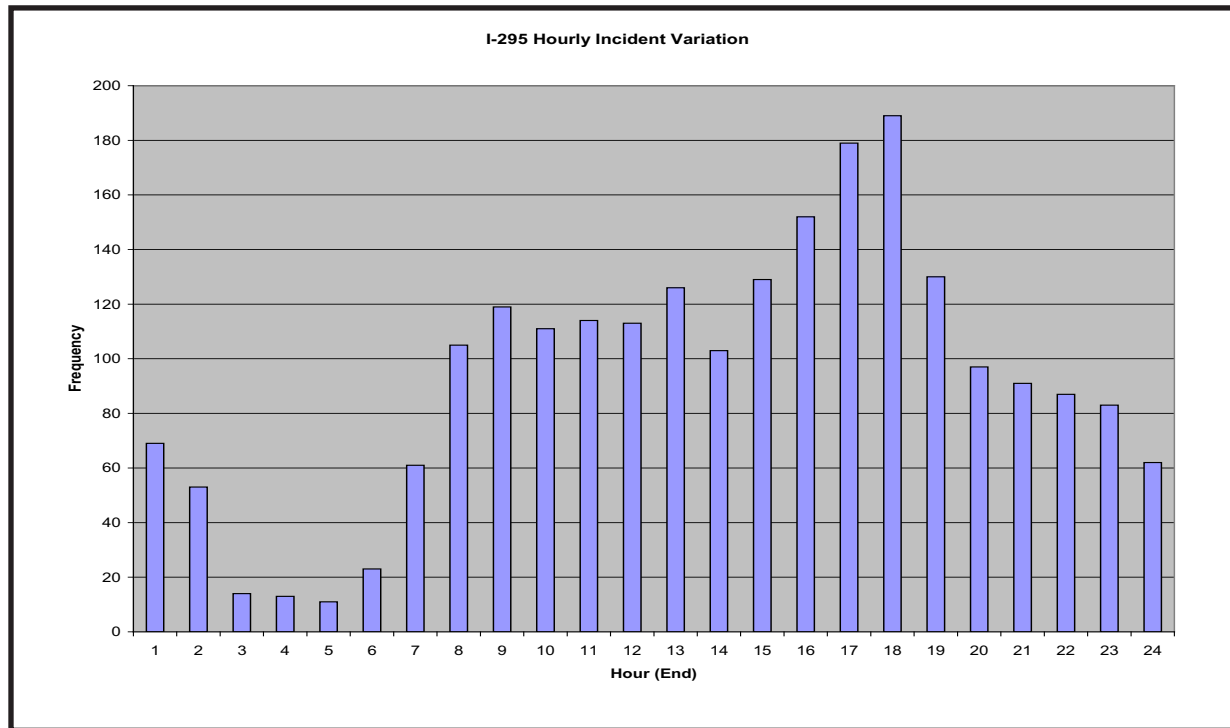

Figure 2.19 shows the hourly incident variation along the study area for both northbound and southbound directions. The peak hours of incidents occur from 4 PM to 6 PM. On average, there are over 100 incidents from 7 AM to 8 PM for the entire year throughout the Study Area.

Figure 2.19: Hourly Incident Variation



Figures 2.20 and 2.21 shows the type of incidents along the thirty mile segment with milepost 1 in Scarborough and milepost 30 in Brunswick. The types of incidents are the same type as shown in figure 2.16 but distributed along the road length. The peak number of incidents in the northbound direction occurs at milepost 4 (78 incidents), this also coincides with the highest number of traffic accidents (28 crashes). The peak number of incidents in the southbound direction occurs at milepost 3 (70 incidents), this also coincides with the highest number of traffic accidents (31 crashes). In general, the greater number of incidents occurs at interchanges.

Figure 2.22 shows a combination of both northbound and southbound total incidents. The northbound is in blue bars and the southbound has red bars. Overall, incidents are nearly balanced between northbound and southbound. Again, the data shows that interchanges have the greater the number of incidents. Much of this can be attributed to traffic accidents (crashes), which occur at more frequency at interchanges, where traffic is merging, diverging and changing speeds.

Figure 2.20: I-295 NB Incident Type by Milepost

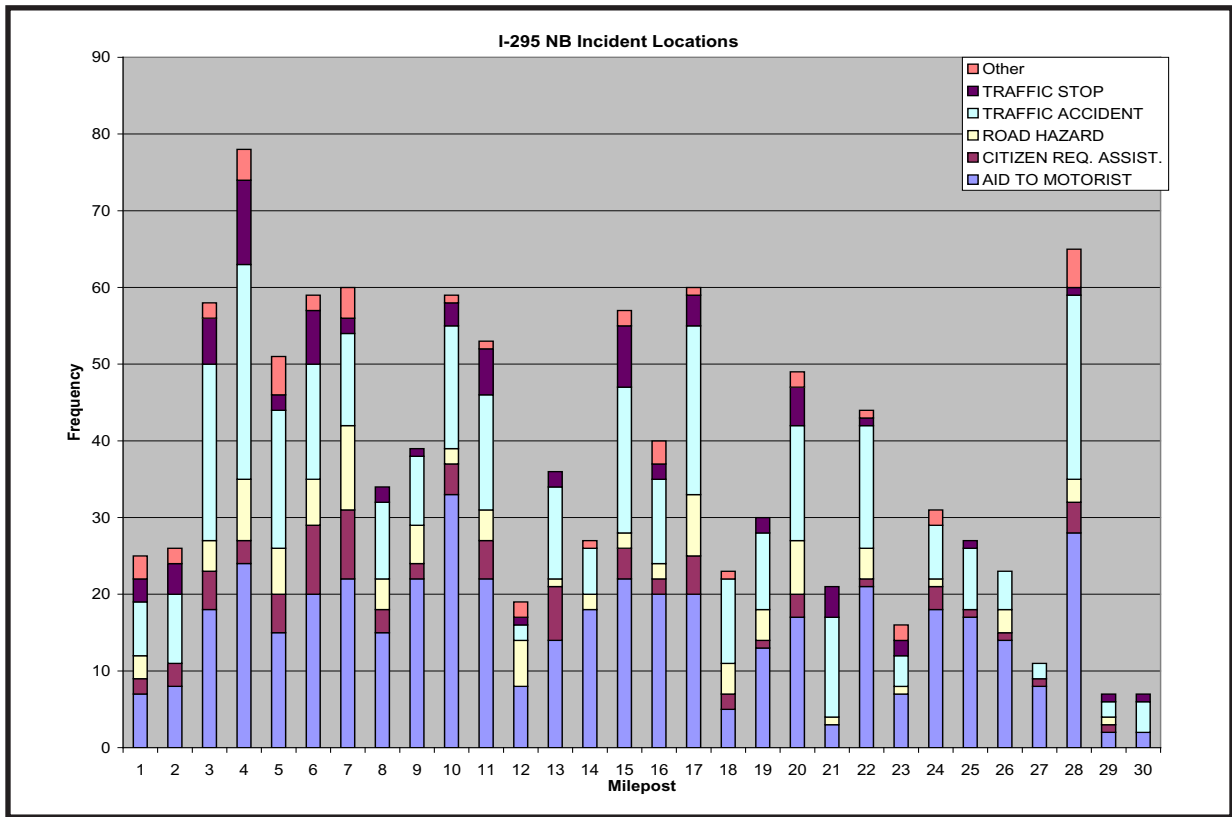

Figure 2.21: I-295 SB Incident Type by Milepost

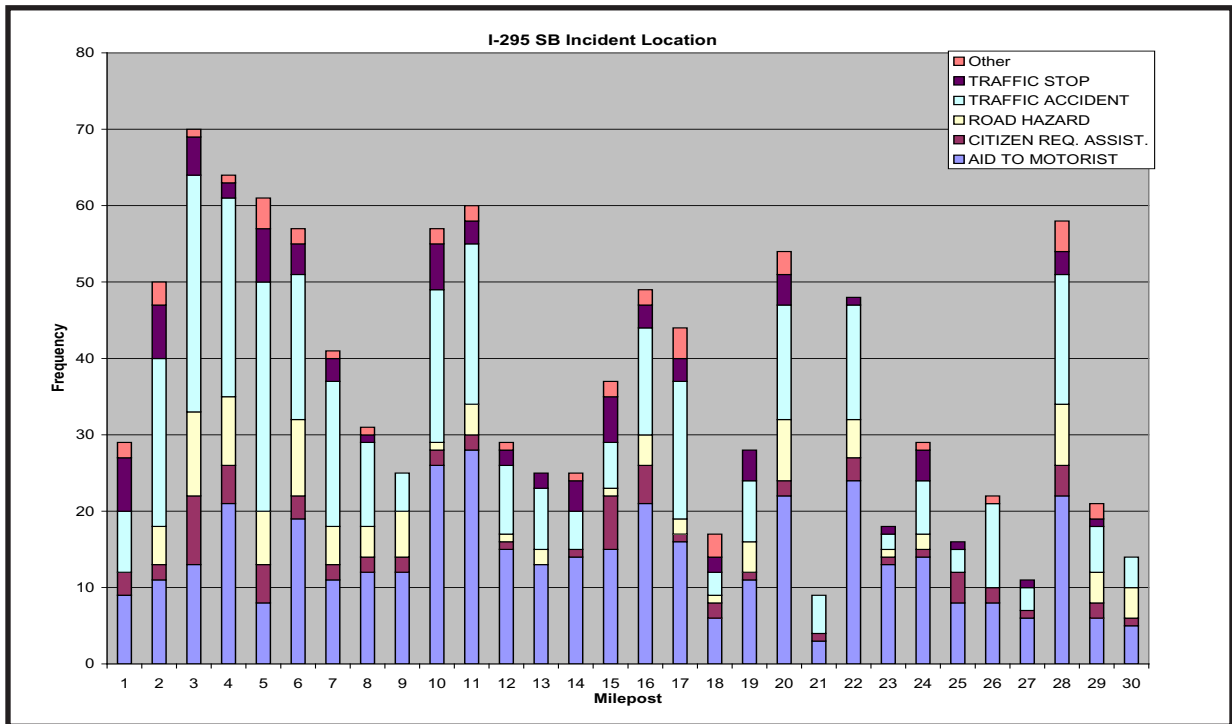
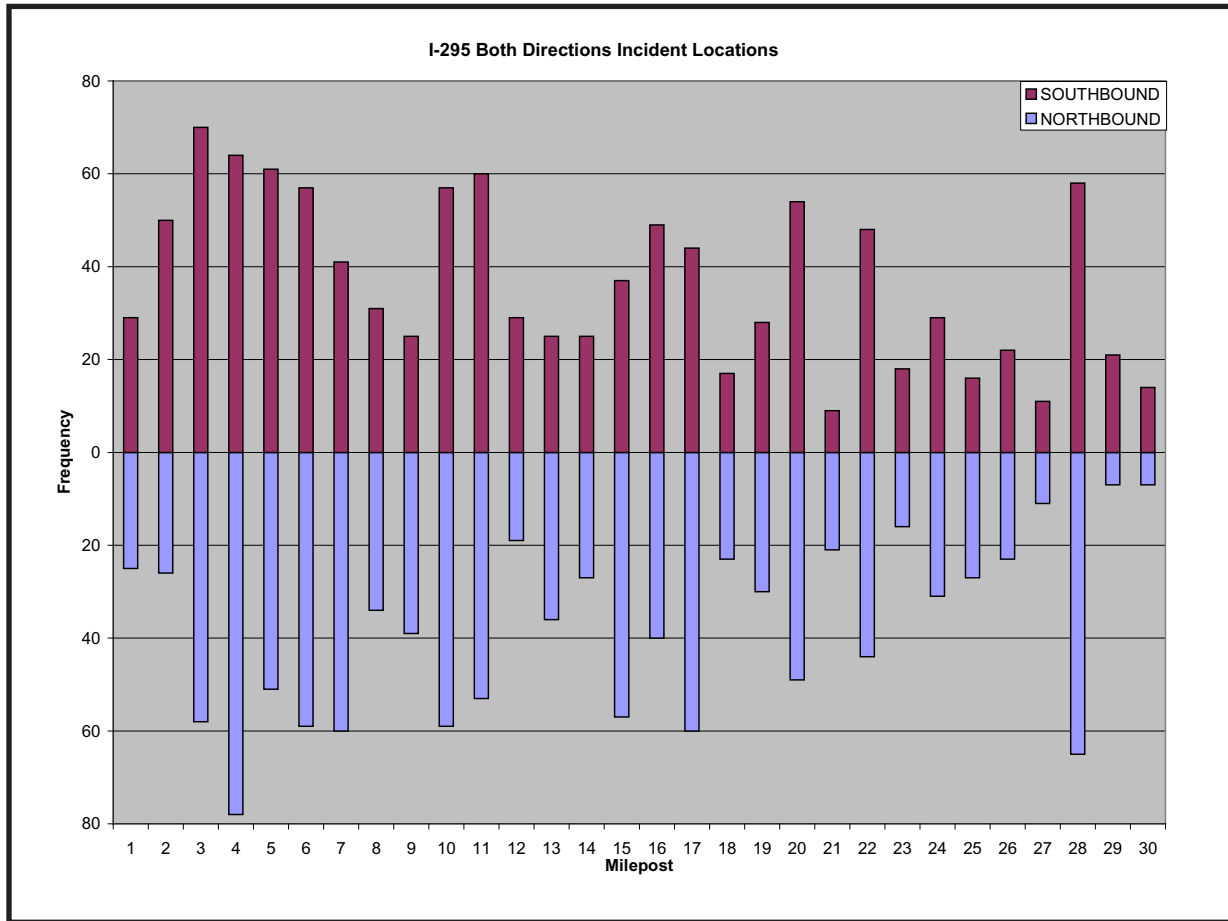

Figure 2.22: I-295 Incidents by Milepost



C. Mobility and Operating Conditions

A major element of this study is the evaluation of operating conditions along I-295 in terms of traffic mobility. To assess mobility, capacity and level of service analyses were conducted for the interstate (freeway) using the current (2000) edition of the Highway Capacity Manual (HCM 2000).

While the majority of the analysis of mobility in the I-295 Corridor Study analysis is for freeway facilities, the HCM 2000 also has methods for analyzing mobility for a broad range of facilities. Facilities are classified into two categories of flow: interrupted and uninterrupted.

Interrupted-flow facilities have controlled or uncontrolled access points that can interrupt the traffic flow. These access points include traffic signals, stop signs, and other types of control that stop traffic periodically (or slow it significantly), irrespective of the amount of traffic. Examples of facility types with interrupted flow include Urban Streets, signalized intersections, two-way stop intersections, and all-way stop intersections.

Uninterrupted-flow facilities have no fixed elements, such as traffic signals, that are external to the traffic stream and might interrupt the traffic flow. Traffic flow conditions result from the interactions among vehicles in the traffic stream and between vehicles and the geometrics and environmental characteristics of the roadway. Examples of facility types with uninterrupted flow include freeways, other multilane highways, and two-lane highways. Freeways operate under the purest form of uninterrupted flow. Not only are there no fixed interruptions to traffic flow, but access is controlled and limited to ramp locations.

Table 2.5 shows different performance measures and flow type for the different types of facilities. Each facility type has a defined method for assessing capacity and level of service. Performance measures reflect the operating conditions of a facility, given a set of roadway, traffic, and control conditions. For example (see Table 2.5 below), freeway level of service is based on density (passenger cars/mile/lane), while signalized intersection level of service is based on delay (seconds/vehicle).

Table 2.5: Facility Types, Flow Types, and Performance Measures

Facility Type	Urban Streets (Forest Ave.)	Signalized Intersections	Two-Way Stop Intersections	Freeways (I-295)
Flow Type	Interrupted	Interrupted	Interrupted	Uninterrupted
LOS Performance Measure	Speed (miles/hour)	Delay (seconds /vehicle)	Delay (seconds /vehicle)	Density (passenger cars /mile/lane)

Capacity is defined as the “maximum sustainable flow rate at which vehicles or persons reasonably can be expected to traverse a point or uniform segment of a lane or roadway during a specific time period under given roadway, geometric, traffic, environmental, and control conditions”. Conditions or factors that affect capacity include the number of travel lanes, lane and shoulder width, lateral clearances, alignment, the characteristics of vehicles in the traffic stream, and traffic control and regulations in existence.

Level of service (LOS) is a qualitative measure describing operational conditions within a traffic stream taking into account a number of variables such as speed and travel time, vehicles maneuverability, traffic interruptions, comfort, and convenience. There are six levels of service defined in the manual ranging from “A” to “F”, with “A” representing the best operational condition and “F” representing the worst. Each level of service represents a range of operating conditions and the driver’s perception of those conditions. Safety is not included in the measures that establish service levels.

According to the HCM 2000 for freeways,

LOS A describes free-flow operations. Free-flow speeds prevail. Vehicles are almost completely unimpeded in their ability to maneuver within the traffic stream. The effects of incidents or point breakdowns are easily absorbed at this level.

LOS B represents reasonably free flow, and free flow speeds are maintained. The ability to maneuver within the traffic stream is only slightly restricted, and the general level of physical and psychological comfort provided to drivers is still high. The effects of minor incidents or point breakdowns are still easily absorbed.

LOS C provides for flow with speeds at or near the free flow speed of the freeway. Freedom to maneuver within the traffic stream is noticeably restricted, and lane changes require more care and vigilance on the part of the driver. Minor incidents may still be absorbed, but the local deterioration in service will be substantial. Queues may be expected to form behind any significant blockage.

LOS D is the level at which speeds begin to decline slightly with increasing flows and density begins to increase somewhat more quickly. Freedom to maneuver within the traffic stream is more noticeably limited, and the driver experiences reduced physical and psychological comfort levels. Even minor incidents can be expected to create queuing, because the traffic stream has little space to absorb disruptions.

LOS E describes operations at capacity. Operations at this level are volatile, because there are virtually no usable gaps in the traffic stream. At capacity, the traffic stream has no ability to dissipate even the most minor disruption, and any incident can be expected to produce a serious breakdown with extensive queuing. Maneuverability within the traffic stream is extremely limited, and the level of physical and psychological comfort afforded the driver is poor.

LOS F describes breakdowns in vehicular flow. Such conditions generally exist within queues forming behind breakdown points. Whenever levels of service F conditions exist, there is the potential for these conditions to extend upstream for significant distances.

Determining an acceptable level of service for freeways requires a balance of what is desirable and what is tolerable. While a freeway maintained at a highly desirable LOS A would be too

costly to build and maintain for all hours of the day, LOS F for all hours of the day would be intolerable for freeway users. Both conditions would be wasteful of time and resources. According to the American Association of State Highway and Transportation Officials (AASHTO), “In heavily developed sections of metropolitan areas, achievements of LOS C may not be practical and the use of LOS D may be appropriate. In rural areas, LOS B is desirable for through and auxiliary lanes, although LOS C may be acceptable.” As shown in the following pages regarding mobility and operating conditions, the users of the I-295 Corridor experience the full range of service levels from A to F. While those traveling in the off-peak direction at the ends of the Study Area experience LOS A, those traveling with peak-hour traffic between Exits 3 and 4 in south Portland have known LOS F. Weighing the practicalities of what is desirable and what is tolerable, the Corridor Advisory Committee expressed a preference for maintaining levels of service at D or better in the I-295 Corridor.

In the HCM 2000, “A freeway is defined as a divided highway with full control of access and two or more lanes for the exclusive use of traffic in each direction. Freeways provide uninterrupted flow. Access to and from the freeway is limited to ramp locations.” (pg. 13-1). The LOS for freeway facilities fall under three different methodologies: basic freeway segments, freeway weaving, and ramp-freeway junctions.

1. Basic Freeway Segments

Basic freeway segments are outside the influence area of ramps or weaving areas of the freeway. According to the HCM 2000 (pg. 13-8); although speed is a major concern of drivers as related to service quality, freedom to maneuver within the traffic stream and proximity to other vehicles are equally noticeable concerns. These qualities are related to density of the traffic stream. Unlike speed, density increases as flow increases up to capacity, resulting in a measure of effectiveness that is sensitive to a broad range of flows.

Basic freeway performance is based on driver freedom to maneuver within the traffic stream and by driver proximity to other vehicles. These qualities are related to density (passenger cars per mile per lane) of the traffic stream. The LOS thresholds for a basic freeway segment are summarized in Table 2.6 below. LOS is defined to represent reasonable ranges in the three critical flow variables; speed, density and flow rate. This is also shown graphically in Figure 2.23 (taken from the HCM 2000).

Table 2.6: Basic Freeway LOS

Level of Service	Density Range (pc/mi/ln)
A	0 -11
B	>11-18
C	>18-26
D	>26-35
E	>35-45
F	>45

Figure 2.23: Speed-Flow Curves and LOS for Basic Freeway Segments

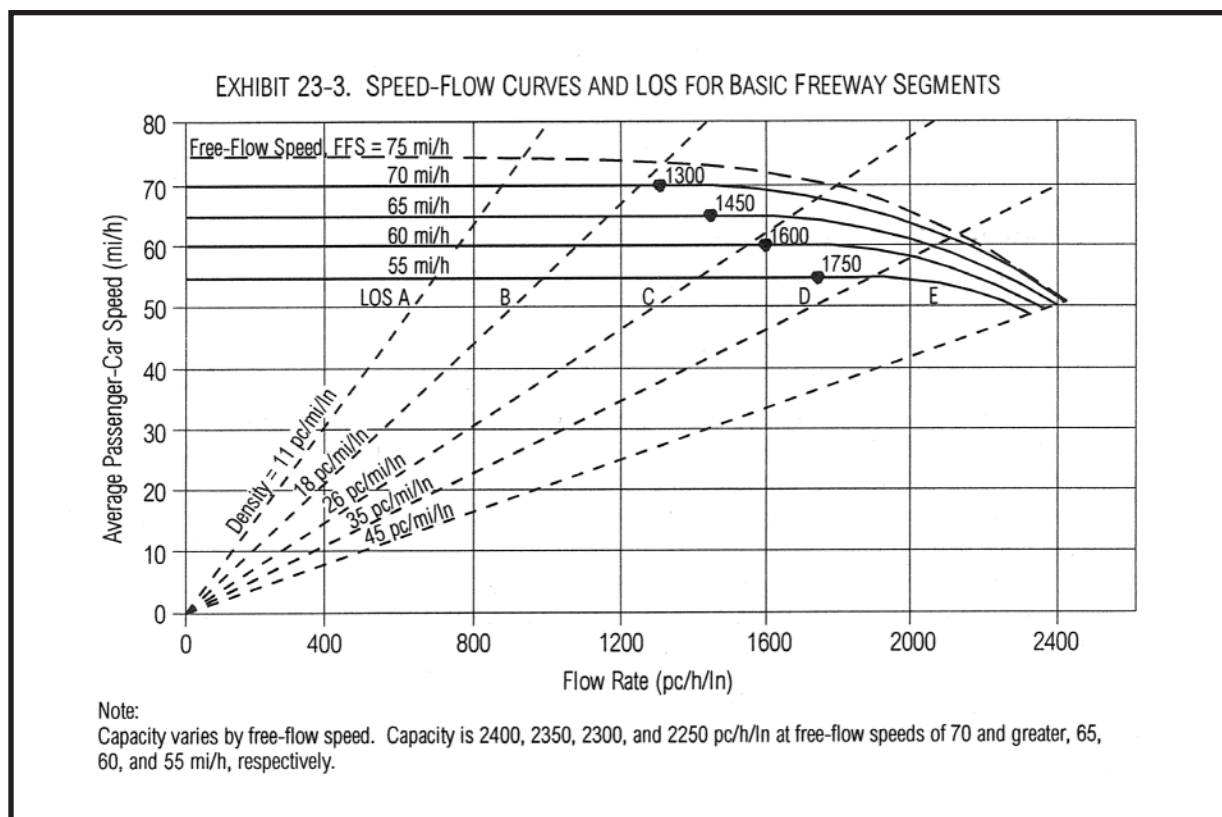

Figure 2.23 also shows that the maximum capacity of a lane on a freeway segment is 2400 passenger cars per hour. However, maximum capacities are lower where the free-flow speeds are lower than 70 miles per hour.

2. Freeway Weaving

According to the HCM 2000, a weaving segment is the length of highway over which traffic streams cross paths through lane change maneuvers, without the aid of traffic signals. Weaving segments are formed when a merge area is closely followed by a diverge area, or when an on-ramp is quickly followed by an off-ramp and the two are joined by an auxiliary lane. Weaving traffic, as represented by the red and blue arrows in Figure 2.13, is the crossing traffic using closely-spaced on- or off-ramps.

The capacity of a weaving segment can never exceed the capacity of a basic freeway segment. Maximum flow rates for weaving traffic cannot exceed 2,800 passenger cars per hour for Type A configuration, 4,000 passenger cars per hour for Type B, and 3,500 passenger cars per hour for Type C. These rates are for weaving volumes regardless of the number of lanes.

The LOS criteria are based on density within the weaving segment, as summarized in Table 2.7.

Table 2.7: LOS Criteria for Weaving Segments

Level of Service	Density Range (pc/mi/ln)
A	<=10.0
B	>10.0-20.0
C	>20.0-28.0
D	>28.0-35.0
E	>35.0-43.0
F	>43.0

3. Ramp Freeway Junctions

Along a freeway segment, vehicles entering and exiting the traffic stream create turbulence that influences freeway operations. Freeway studies have shown that the influence of merging (on-ramp) and diverging (off-ramp) vehicles on freeway flow is generally confined within an area extending upstream or downstream from the ramp junction. In the analysis of influence areas, merge influence areas and diverge influence areas are treated separately.

The merge influence area includes the two right-most freeway lanes and the acceleration lane, extending a distance 1500 feet downstream of the physical gore of the ramp junction. Freeway vehicles traveling in the two right-most lanes will move to the left in order to avoid turbulence created by merging vehicles. This operational effect increases with increasing merging volume. The level of turbulence is also affected by the length of the acceleration lane. A longer lane provides merging vehicles with more opportunities to find and accept gaps in the freeway traffic stream. The maximum desirable flow entering a merge influence area is equal to 4600 passenger cars per hour in the right-most two mainline lanes plus the on-ramp. Demand exceeding this value will cause locally high densities, but will not necessarily cause queuing on the freeway. Queuing will occur when the total flow departing from the merge segment exceeds the capacity of the downstream basic freeway segment.

The diverge influence area includes the two right-most freeway lanes and the off-ramp deceleration lane, extending a distance of 1500 feet upstream of the physical gore of the off-ramp junction. The operational effect is dependent on the volume of vehicles exiting the freeway and the length of the deceleration lane. The maximum desirable flow approaching a diverge influence area is equal to 4,400 passenger cars per hour in the right-most two freeway lanes, measured upstream of the deceleration lane. Demand exceeding this value will cause locally high densities but will not necessarily cause queuing on the freeway. Queuing will occur when the total flow approaching a diverge segment exceeds the capacity of the basic freeway segment that is immediately upstream. Queuing will also occur when the capacity of the exit leg is exceeded. Ramp-street terminal problems can cause queuing along the length of the ramp.

The LOS in merge and diverge influence areas is based on traffic density of the influence area as shown in Table 2.8.

Table 2.8: LOS Criteria for Merge and Diverge Area

Level of Service	Density Range (pc/mi/ln)
A	≤10.0
B	>10.0-20.0
C	>20.0-28.0
D	>28.0-35.0
E	>35.0
F	Demand exceeds capacity

Appendix 2 and Appendix 3, respectively, include diagrams of the 2002 AM and PM peak design hour volumes and the LOS (existing conditions) for the Study Area. The diagrams show the mainline DHV, ramp DHV, and weaving area DHV. The ramp volumes that show a negative value are exiting vehicles (off-ramps), and the positive values are volumes of entering vehicles (on-ramps). The diagrams also indicate the type of weave (A, B or C as shown in Figure 2.13). The level of service is color coded for each segment; if the segment has letters then the LOS is within one passenger car/mile/lane of the next LOS.

Tables 2.9 and 2.10 below are summaries of Appendix 2 and Appendix 3, respectively. Each table is broken into two parts: On- and off-ramps, and segments between on and off Ramps. There are 65 on- and off-ramps, 32 in the southbound direction and 33 in the northbound direction, and 41 mainline segments, 20 in the southbound and 21 in the northbound. Tables 2.9 and 2.10 do not distinguish between weaving and non-weaving segments.

The tables show that existing peak-hour levels of service on I-295 range from A to F, with a majority of locations operating at LOS C or D. Overall, the PM peak hour, with higher numbers in LOS D, E, and F, operates at a lower level of service than the AM peak hour. More detailed LOS information on individual freeway segments and ramp junctions can be found in Appendices 2 and 3.

Table 2.9: 2002 LOS AM Peak

		2002 Level of Service AM Peak					
		A	B	C	D	E	F
On/Off Ramps	Southbound	2	2	18	9	1	0
	Northbound	2	18	10	2	1	0
Segments Between On/Off Ramps	Southbound	3	2	8	6	1	0
	Northbound	2	13	4	2	0	0

Table 2.10: 2002 LOS PM Peak

		2002 Level of Service PM Peak					
		A	B	C	D	E	F
On/Off Ramps	Southbound	2	8	13	7	1	1
	Northbound	1	3	1	23	5	0
Segments Between On/Off Ramps	Southbound	1	9	5	4	1	0
	Northbound	1	2	7	9	2	0

D. Other Transportation Facilities and Services

I-295 is the core of a transportation network of facilities and services that serves the corridor around I-295. The following describes some of the other key facilities and services in the I-295 Corridor.

1. Highways

Route 1

Route 1 runs parallel to I-295, mostly to the east of it. Before I-295 was built, Route 1 was the major north/south highway between Portland and Brunswick. Currently, Route 1 interchanges traffic with I-295 directly at Exits 4, 9, 15, 17, 24, and 28. Other I-295 interchanges such as Exits 1, 2, 10, 20, and 22 have close connections to Route 1. Between Exits 4 and 9, I-295 is also designated as Route 1.

Because it is in close proximity and has easy access to I-295, Route 1 can serve as an alternate route for north/south traffic. If there is an incident on I-295 many vehicles will divert over to Route 1 both north and south of Portland. Because Route 1 provides access to village centers and other land developments in most of the municipalities in the I-295 Corridor, travel speeds are normally lower on Route 1 than on I-295.

Maine Turnpike

The Maine Turnpike is a controlled-access toll highway extending from Kittery in southern-most Maine to Augusta, by way of Portland and Lewiston-Auburn. The Maine Turnpike carries the designation of I-95, which extends beyond the Maine Turnpike north through Maine to Houlton and south along the Atlantic seaboard of the United States.

Also a part of the Maine Turnpike is a controlled-access highway, located in Falmouth, that connects I-95 and I-295. This stretch of highway, known as the Falmouth Spur, when used in combination with I-95, provides an alternative route to I-295 for traffic passing through the Portland/South Portland area between Falmouth and Scarborough.

2. Railroads

Pan Am Railways

Pan Am Railways, formerly the Guilford Transportation System, is a freight railroad connecting Portland to both the north, toward Yarmouth, Brunswick, Auburn, and Maine points north and east, and to the south, toward Boston and points west. Pan Am is the host railroad for the Amtrak Downeaster passenger rail service between Portland and Boston and is also the potential host for the extension of Amtrak service from Portland to Brunswick.

St. Lawrence & Atlantic Railroad

The St. Lawrence & Atlantic Railroad, by way of Yarmouth and Auburn, provides freight service between Portland and the Montreal area at Sainte-Rosalie, Quebec. Between Portland and Yarmouth, the St. Lawrence & Atlantic right of way is owned by MaineDOT and closely parallels I-295.

3. Transit and Ridesharing Services

Local Bus Services

Two fixed-route local bus services operate in the I-295 Corridor. METRO serves Portland, Westbrook, the Maine Mall in South Portland, and the Falmouth Crossing, and carries 1.5 million riders annually. The South Portland Bus Service serves South Portland and downtown Portland, and carries 200,000 riders annually.

ZOOM Bus

The ZOOM Bus is an express commuter bus service that connects the Biddeford-Saco area with the Portland Peninsula. ZOOM carries 40,000 riders annually.

GO Maine

GO Maine is a statewide service for commuters that promotes ridesharing, transit use, and other transportation demand management (TDM) options. GO Maine coordinates carpools and vanpools statewide and has over 8000 registered participants and more than 20 operating vanpools, many of which use the I-295 Corridor.

4. Park-and-Ride Facilities

Portland Transportation Center

The Portland Transportation Center, located at I-295 Exit 5, is an intermodal passenger transportation facility with a 750-space park-and-ride area and a passenger terminal serving users of Amtrak Downeaster trains, Concord Coach intercity buses, and local bus services. Over 750,000 passengers use the Portland Transportation Center to make connections to alternative transportation modes.

Other Park-and-Ride Facilities

Other designated park-and-ride facilities are located near several interchanges along the Study Area of the I-295 Corridor. These designated parking lots have been built and maintained by MaineDOT and the Maine Turnpike Authority to encourage ridesharing and transit use and are summarized in Table 2.11. Other park-and-ride facilities spread out beyond the Study Area are also available to serve travelers bound for the I-295 Corridor.

Table 2.11: Other Park-and-Ride Facilities

Town/City	Location	Sponsor	Parking Spaces
South Portland	I-95 Exit 45, near I-295 Exit 1	MaineDOT/ Maine Turnpike Authority	111
Portland	I-295 Exit 7	MaineDOT	200
Yarmouth	I-295 Exit 17	MaineDOT	32
Freeport (South)	Route 1, between Exits 17 and 20	MaineDOT	50
Freeport (North)	I-295 Exit 20	MaineDOT	22

5. Bicycle and Pedestrian Facilities

The Greater Portland area has a developing network of bicycle lanes, shoulders, sidewalks, crosswalks, and off-road connections to serve the transportation needs of bicyclists and pedestrians in the area communities. Some of these facilities parallel or cross the I-295 Corridor and its interchanges.

E. Environmental Overview

The I-295 Corridor, between Scarborough and Brunswick, passes through a varied natural and man-made environment. Table 2.12 summarizes the major environmental features east and west of the I-295 right-of-way for the 28 miles from Scarborough to Brunswick.

1. Physical and Biological Environment

Located within a few miles of the coast of southern Maine, I-295 is in close proximity of several notable tidal bodies of water in the southern part of the corridor. Among these are Long Creek in South Portland, the Fore River, Back Cove and Casco Bay in Portland, the Presumpscot River in Falmouth, and the Royal River in Yarmouth.

Land types along the corridor are dominated by urban uses in the southern portion, but gradually giving way to forested rural land in the northern portion.

2. Land Use, Cultural, Social, and Economic Environment

A mix of urban land uses can be found along the I-295 Corridor. From Scarborough through Portland, land uses are mainly commercial or urban residential. In several locations, the I-295 Corridor closely parallels transportation facilities such as the Union Branch (railroad) corridor in Portland, the St. Lawrence & Atlantic Railroad in Falmouth and Cumberland, and Route 1 in Cumberland. Nearby village settings can be found in Yarmouth and Freeport.

The key cultural and social resources along the Corridor are the recreational and educational facilities in Portland. Located in the area between Exits 5 and 8 are resources such as Back Cove, Hadlock Field, Fitzpatrick Stadium, tennis courts, ball fields, Deering Oaks Park, and the University of Southern Maine campus. Deering Oaks is also listed on the National Register of Historic Places.

At the I-295 interchanges, traffic to and from I-295 interacts with the local traffic environment, which includes pedestrian and bicycle traffic, particularly in urban locations.

3. Atmospheric Environment

The atmospheric environment of the I-295 Corridor has two major components: air and noise.

Under the rules of the Clean Air Act and Clean Air Act Amendments of 1990, air quality in Maine's Area 1, where I-295 is located, has recently been redesignated from a non-attainment area to an attainment area. Area 1 has been shown to meet current air quality standards, but continues to be closely monitored for compliance.

Noise conditions in the I-295 Corridor are believed to vary considerably depending on location. Areas near highway segments with more traffic volume or areas closer to the highway will tend to have higher levels of highway noise. At least two areas near I-295 have been observed to have noise levels above 66 decibels (dBA). One is in the urban residential neighborhood near Exit 9 in Portland, and the other is in the urban residential neighborhood adjacent to the east side of I-295 between Exits 3 and 4 in South Portland.

Table 2.12: Affected Environment Along I-295 Corridor

City/Town	West Side Resources/Constraints	Corridor	East Side Resources/Constraints
Brunswick	rural area	Exit 28	rural area
Freeport	rural area	Exit 24	Route 1
	suburban area	Exit 22	Freeport village area
Freeport	suburban area	Exit 20	Route 1 commercial area
Yarmouth	Yarmouth village area	Exit 17	Yarmouth village area
Yarmouth		Exit 15	
Cumberland	St. Lawrence & Atlantic R.R.		Route 1
Falmouth	St. Lawrence & Atlantic R.R.	Exit 11	Route 1 commercial area
Falmouth	St. Lawrence & Atlantic R.R.	Exit 10	
Portland	urban residential area	Exit 9	urban residential area
			industrial area
	Back Cove, ped/bike trail	Exit 8	Casco Bay
		Exit 7	potential rail corridor, Marginal Way urban residential & commercial area
	commercial area	Exit 6	Union Branch, Deering Oaks Park
	urban residential area, USM		
Portland	rail/bus passenger terminal	Exit 5	urban residential area
	Fore River		Fore River
South Portland	Long Creek	Exit 4	industrial area
			urban residential area
	Long Creek commercial area	Exit 3	West Broadway
		Exit 2	
South Portland		Exit 1	West Broadway
Scarborough	commercial area		commercial area
		I-95	

III. Future Conditions

To evaluate the impact of future travel on the Corridor Study Area, 2025 hourly traffic volume conditions were projected by Portland Area Comprehensive Transportation System (PACTS) travel demand model. The PACTS travel demand model is based on anticipated growth of population and employment in the Greater Portland area. The PACTS forecast used in the *Destination Tomorrow* plan and the I-295 Corridor Study covered a time period between 2000 and 2025. In general, the PACTS forecast predicted a traffic volume increase on I-295 of 20% during this time period. While any travel demand forecast has a degree of uncertainty and economic conditions can vary between strong and weak, it is reasonable to expect that, during this time period, the economy and population of Greater Portland will grow. The PACTS travel demand forecast serves a reasonable basis for analyzing future conditions.

A. Mobility and Operating Conditions

For the purpose of analysis, the 2025 No-Build assumptions in the PACTS model included the following:

- The I-295 Connector (Fore River Parkway) is complete and operating.
- Local bus and van pool service is improved.
- Amtrak passenger rail service is extended to Brunswick.
- No significant changes in the regional toll collection structure.
- I-95 north of Exit 44 has four lanes.

A detailed list of network assumptions as provided by PACTS is found in Appendix 4.

The baseline or No-Build strategy would maintain the existing corridor infrastructure, but would not make any improvements on I-295 or any parallel transportation route that could affect transportation operations on I-295. The No-Build strategy was used as a base for comparison to other alternatives.

The effects of projected Year 2025 traffic volumes on the operating conditions of basic freeway segments, freeway weaving, and freeway ramps were evaluated using the same analysis procedure described under Section II C, Existing Conditions.

Appendix 5 and Appendix 6, respectively, include diagrams of the 2025 AM and PM peak design hour volumes and the level of service (future No-Build conditions) for the Study Area. Table 3.1 below is a summary of the 2025 LOS for the Corridor in the AM Peak. In comparison with the existing AM Peak (Table 2.8), the future AM conditions would be significantly worse.

Table 3.1: 2025 No-Build LOS AM Peak

		2025 No-Build Level of Service AM Peak					
		A	B	C	D	E	F
On/Off Ramps	Southbound	0	4	5	15	7	1
	Northbound	0	13	9	6	3	2
Segments Between On/Off Ramps	Southbound	1	2	6	6	4	1
	Northbound	1	10	4	4	1	1

As shown in Table 3.1, almost half (51 of 106) of the ramps and mainline segments would be LOS D, E or F. In 2025, there would be five LOS F's (compared to none for the 2002 AM Peak). The three northbound LOS F's occur between Exit 3 and Exit 4; the two southbound LOS F's occur between Exit 8 and Exit 7. In 2025, there would be 15 LOS E's (compared to three for the 2002 AM Peak). LOS D's would increase from 19 (for 2002 AM Peak) to 31. For the 2025 No-Build AM Peak, the only remaining LOS A's would be at the ends of the Corridor.

Table 3.2 below is a summary of the 2025 LOS for the Corridor in the PM Peak. In comparison with the existing PM Peak (Table 2.9), the future PM conditions would be significantly worse.

Table 3.2: 2025 No-Build LOS PM Peak

		2025 No-Build Level of Service PM Peak					
		A	B	C	D	E	F
On/Off Ramps	Southbound	0	8	7	10	1	6
	Northbound	1	2	1	8	17	4
Segments Between On/Off Ramps	Southbound	0	6	7	2	3	2
	Northbound	1	1	2	6	8	3

As shown in Table 3.2, two-thirds (70 of 106) of the ramps and mainline segments would be LOS D, E or F. Northbound between Exits 3 and 15, the LOS would almost always E or F. There would be 15 LOS F's (compared to one for the 2002 PM peak). The seven northbound LOS F's would occur from Exit 6 to north of Tukey's Bridge (between Exit 5 and Exit 9); the eight southbound LOS F's would occur from Exit 6 to Exit 3 (between Exit 6 and Exit 3). There would be 29 LOS E's (compared to nine for the 2002 AM Peak). LOS C's and B's would decrease (compared to 2002 PM Peak) and only two LOS A's would remain.

As shown in Table 3.3, there are ten locations in South Portland and Portland where future demand would exceed freeway capacity. Each of these locations would also operate at LOS F during AM and/or PM peaks. Figure 3.1 shows queuing impacts for those ten locations. In Figure 3.1, the vertical length of each bar shows how extensive the queue would be from the choke point upstream. For example, the blue bar in the left-most column corresponds with the Exit 8 to 7 southbound AM Peak (which is the seventh row in Table 3.3). Demand would exceed capacity by 652 vehicles per hour, which would likely result in a queue extending upstream to Exit 10. The most serious queuing problem would occur between Exit 4 and Exit 3 southbound during the PM Peak. This red bar starts between Exit 4 and Exit 3 in South Portland and extends all the way through Portland to Exit 11 in Falmouth.

Table 3.3: 2025 No-Build -Capacity Deficits in the I-295 Corridor

I-295 Location	Direction	Peak Hour	Demand in 2025 vph	Baseline	
				Capacity vph	Deficit (-) vph
				Exit 3 to Exit 4	NB
Exit 3 to Exit 4	NB	PM	4152	4035	-117
Exit 5 to Exit 6	NB	PM	4056	4035	-21
Exit 6 to Exit 7	NB	PM	4430	4025	-405
Exit 7 to Exit 8	NB	PM	5299	4949	-350
Exit 8 to Exit 9	NB	PM	4249	4165	-84
Exit 8 to Exit 7	SB	AM	4769	4117	-652
Exit 6	SB	PM	3956	3857	-99
Exit 5 to Exit 4	SB	PM	4230	4035	-195
Exit 4 to Exit 3	SB	PM	4980	4035	-945

Figure 3.1: 2025 Capacity Constraints Queuing Impacts

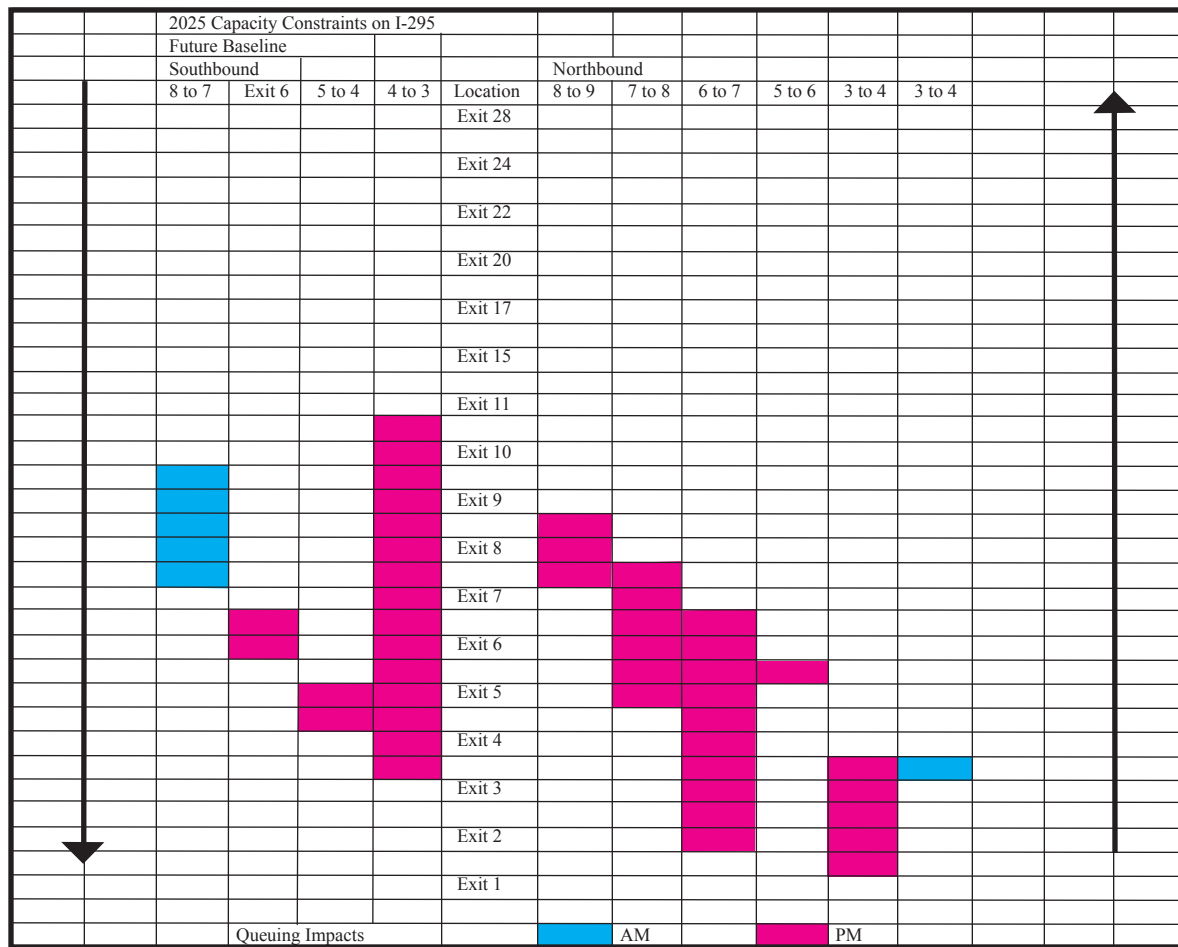

B. External Factors and Trends

The analysis of 2025 traffic projections in the I-295 Corridor provides a reasonable estimate of future traffic conditions based on anticipated growth of population and employment in the Greater Portland area. However, some external factors and trends, as discussed below, could have a substantial impact on future traffic volumes and congestion levels.

Aging Population

The population of the United States is aging. As the wave of “baby boomers”, born between 1945 and 1965, enter their 60’s, 70’s, and 80’s, the driving habits of a large segment of our population will change. Older people drive less and rely on public transportation more. This trend will tend to slow the growth of automobile travel.

New Technology

Changes in technology continue in the transportation field. Automobiles are increasingly equipped with GPS and sensor technology that allows greater automation in the navigation and control of the vehicle. Automatic sensors and communication devices in highways are providing better information to drivers about conditions ahead. Electronic toll collection without toll booths is available now and spreading across the country. The combination of more intelligent vehicles and highways may lead to greater automation of the driving task and allow the closer spacing of vehicles, and greater vehicular capacities, on controlled access highways.

Energy Costs

Recent experience has shown that increases in the price of gasoline can reduce automobile travel, at least in the short term. The future price of motor fuels is difficult to predict, but rising demand for fuel in rapidly growing economies in China, India, and other parts of the developing world will put increasing pressure on petroleum supplies and upward pressure on energy prices. These pressures will push transportation in the United States more toward alternative fuels, fuel-efficient vehicles, and other modes of transportation.

Transportation Funding

Transportation funding by conventional motor fuel taxes is unable to keep up with financial demands of maintaining and improving the highway system. The energy trends of higher fuel prices and less dependence on gasoline and diesel fuels, coupled with rising highway and bridge construction costs, are creating a widening gap between revenues and needed expenditures. This trend will push policy makers to find new means of collecting revenue for transportation.

IV. Alternatives Analysis

In the alternatives analysis, many potential improvements were evaluated. The evaluations took into account effectiveness in addressing I-295 Corridor needs, cost of implementation, environmental and other issues, and the ability to work well with other alternatives.

A. Strategies, Actions and Options

To address the existing and future needs of the I-295 Corridor, a broad range of strategies was analyzed. Each strategy represents a different approach toward solving the problems in the Corridor. Some strategies are oriented toward specific locations in the Corridor while others are corridor-wide. Some are directed at physical improvements to the highway while others are directed at relieving the traffic demand on the Corridor.

Within each strategy, may be one or more actions. The actions are specific projects or programs to address the deficiencies in the I-295 Corridor. Most of these actions are location-specific. Table 4.1 shows the strategies and actions analyzed for the I-295 Corridor Study.

For some actions there are multiple options. These are variations of the action that are aimed at achieving the same purpose. An example of options would be the various interchange configurations possible to make Exit 15 in Yarmouth a full-service interchange.

Table 4.1 Strategies and Actions

Strategies	Characteristics	Actions
Auxiliary Lanes	<ul style="list-style-type: none"> ● Relatively low cost ● Targeted toward specific interchange ramps or short highway segments ● For improved efficiency and safety at on-ramp and off-ramps 	<ul style="list-style-type: none"> ● Weaving section improvements between Exits 3 and 4 in South Portland ● Weaving section improvements on I-295 approaches to Exit 7 in Portland ● Acceleration and deceleration lane improvements at various locations from Falmouth to Freeport
Intelligent Transportation Systems (ITS)	<ul style="list-style-type: none"> ● Relatively low cost ● Applies corridor-wide or to portion of the corridor ● For improved efficiency of existing facilities 	<ul style="list-style-type: none"> ● Variable message signing in Portland and South Portland ● Traffic surveillance ● Service patrols to aid motorists
Transportation Demand Management (TDM)	<ul style="list-style-type: none"> ● For relief of travel demand in the corridor ● Involves incentives to change driver behavior 	<ul style="list-style-type: none"> ● High-occupancy vehicle lanes ● Carpool incentives ● Differential tolls to redirect thru traffic
Commuter Transit	<ul style="list-style-type: none"> ● For relief of travel demand in the corridor ● Involves alternative transportation facilities and services 	<ul style="list-style-type: none"> ● Commuter bus service to Portland from north and south ● Commuter rail service to Portland from north and south
Interchange Improvements	<ul style="list-style-type: none"> ● Major improvements at specific interchanges 	<ul style="list-style-type: none"> ● Added ramps at Exits 4, 11, and 15 ● Reconfiguration of Exit 6
New Highway Capacity	<ul style="list-style-type: none"> ● For added vehicular capacity ● Involves construction of additional lanes for use by general traffic 	<ul style="list-style-type: none"> ● Added thru lanes on I-95 in Portland and South Portland (Maine Turnpike Authority) ● Added thru lanes on I-295 in Portland and South Portland ● Added thru lanes on I-295 from Falmouth to Brunswick

B. Auxiliary Lanes

This strategy relies on relatively low-cost actions. For urban sections these include the construction of additional travel lanes at I-295 ramps or along short segments of I-295 between interchanges. In rural locations, auxiliary lane improvements would typically involve extensions to on-ramp acceleration lanes and off-ramp deceleration lanes. While auxiliary lanes themselves do not add thru-lane capacity, they do improve traffic safety and allow thru lanes to more completely achieve their capacity potential. The auxiliary lanes strategy does not include thru travel lanes and would not involve construction requiring new or expanded bridges.

Appendix 7 and Appendix 8, respectively, include diagrams of the 2025 AM and PM peak design hour volumes and the level of service, comparing the auxiliary lane strategy to the baseline (No-Build) for the Study Area. Table 4.2 below is a summary of the 2025 auxiliary lanes LOS for the Corridor in the AM peak. In comparison with the future No-Build AM peak (Table 3.1), the auxiliary lane strategy would eliminate the five LOS F's and maintain the number of LOS E's at 15. The improved LOS would occur mostly at the rural on- and off-ramps.

Table 4.2: 2025 Auxiliary Lanes LOS AM Peak

		2025 Aux. Lanes LOS AM Peak					
		A	B	C	D	E	F
On/Off Ramps	Southbound	0	4	13	9	6	0
	Northbound	0	19	3	8	3	0
Segments Between On/Off Ramps	Southbound	1	2	7	5	5	0
	Northbound	1	10	4	5	1	0

Table 4.3 is a summary of the 2025 auxiliary lanes LOS for the Corridor in the PM Peak. In comparison with the future No-Build PM peak (Table 3.2), the auxiliary lane strategy reduces the number of LOS F's from 15 to 9 and LOS E's from 28 to 25.

Table 4.3: 2025 Auxiliary Lanes LOS PM Peak

		2025 Aux. Lanes LOS PM Peak					
		A	B	C	D	E	F
On/Off Ramps	Southbound	0	9	11	5	3	4
	Northbound	1	2	2	16	10	2
Segments Between On/Off Ramps	Southbound	0	6	8	1	4	1
	Northbound	1	1	2	7	8	2

As shown in Table 4.4 below, all AM peak capacity deficits are eliminated by auxiliary lanes. Three of the eight PM peak capacity deficits also are eliminated with this strategy. Of the deficits that remain, the most serious are at Exit 7 to Exit 8 northbound and Exit 5 to Exit 4 southbound. (See section IV. B.3. for more detail.)

Table 4.4: 2025 Auxiliary Lanes - Deficits in the I-295 Corridor

I-295 Location	Direction	Peak Hour	Demand in 2025 vph	Baseline		With Auxiliary Lanes	
				Capacity	Deficit (-)	Capacity	Deficit (-)
				vph	vph	vph	vph
Exit 3 to Exit 4	NB	AM	4560	4117	-443	4860	0
Exit 3 to Exit 4	NB	PM	4152	4035	-117	4775	0
Exit 5 to Exit 6	NB	PM	4056	4035	-21	4035	-21
Exit 6 to Exit 7	NB	PM	4430	4025	-405	4669	0
Exit 7 to Exit 8	NB	PM	5299	4949	-350	4949	-350
Exit 8 to Exit 9	NB	PM	4249	4165	-84	4165	-84
Exit 8 to Exit 7	SB	AM	4769	4117	-652	5261	0
Exit 6	SB	PM	3956	3857	-99	3857	-99
Exit 5 to Exit 4	SB	PM	4230	4035	-195	4035	-195
Exit 4 to Exit 3	SB	PM	4980	4035	-945	5294	0

Figure 4.1 below is a modified version of Figure 3.1 to show the impact that auxiliary lanes can have on the extent of queuing on I-295 in the AM and PM peak hours. The lighter colors indicate the queuing reductions obtained by use of auxiliary lanes. The darker colors and the question marks indicate locations where capacity deficits cannot be resolved by use of auxiliary lanes alone.

Figure 4.1: 2025 Auxiliary Lanes - Capacity Constraints Queuing Reductions

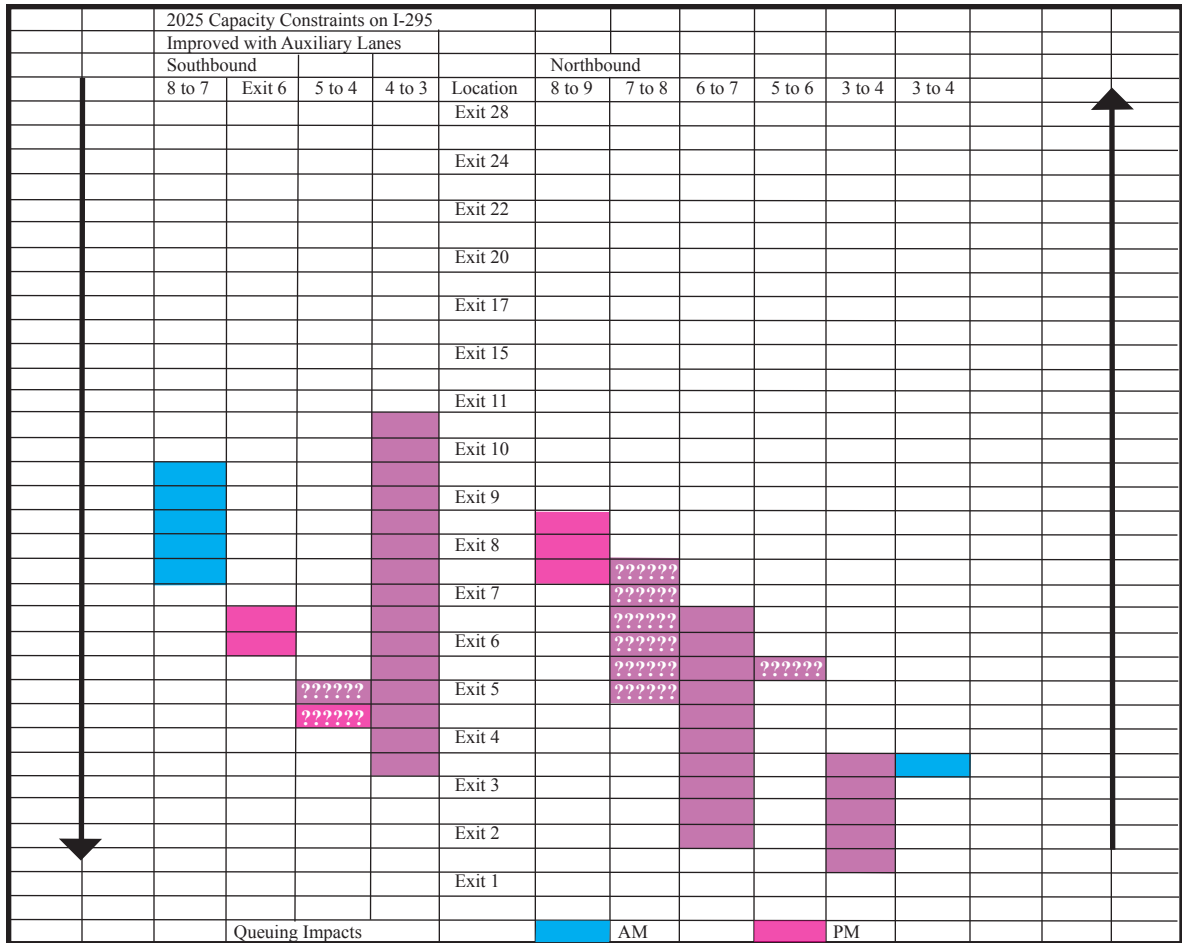

1. Weaving Sections

In urban areas, the auxiliary lane strategy consists mainly of weaving sections. These include the construction of additional travel lanes at I-295 ramps or along short segments of I-295 between interchanges. Weaving section actions have been identified at four locations: southbound from the Exit 4 on-ramp to the Exit 3 off-ramp, northbound from the Exit 3 on-ramp to the Exit 4 off-ramp, northbound from the Exit 6 on-ramp to the Exit 7 off-ramp, and southbound from Exit 8 to the Exit 7 off-ramp. The following provide more detail about the elimination of some of the capacity deficit locations.

Southbound Exit 4 On-Ramp to Exit 3 Off-Ramp

I-295 southbound between Exits 4 and 3 is one of the highest volume two-lane segments of Interstate Highway in Maine. In 2002, the AADT was approximately 38,000 vehicles per day,

with PM peak-hour traffic volumes of 4000 vehicles per hour. Due to the limited highway capacity, the inadequate acceleration and deceleration lengths of the ramps, and the high volume of weaving and non-weaving traffic, this location is now chronically congested during the PM peak period and operates at level of service F. The resulting congestion has created a High Crash Location with a high rate of rear-end crashes on I-295 Southbound between Exits 5 and 4.

In analyzing the options for this location, both Type A and Type B weave options were considered. The weave Type A (with one-lane off-ramp) and the no-build failed for the 2025 PM peak. Based on the analysis, a Type B weave (see Figure 2.13) would be the most effective option. This includes construction of a southbound auxiliary lane along the right shoulder of I-295 between Exit 4 and 3 and a second lane for the Exit 3 southbound off-ramp. The addition of the auxiliary lane would relieve the capacity constraints (Table 4.4) at this location, increase the effective acceleration and deceleration lengths of the ramps, improve the efficiency of weaving traffic movements, and improve the level of service. Table 4.5 below shows that the AM peak hour LOS would improve with a Type B weave from D to C, and in the PM peak it would improve from F to E. The addition of a second lane for the Exit 3 off-ramp would further improve weaving characteristics. As a result of the auxiliary lane, the rate of crashes at Exit 4 on-ramp would be reduced.

Table 4.5: 2025 SB Exit 4-to-3 LOS Impacts with Auxiliary Lane Improvements

	2025 AM No-Build	2025 AM Type B Weave	2025 PM No-Build	2025 PM Type B Weave
SB Exit 4 On-Ramp	D	C	F	E
SB Exit 4 to Exit 3	D	C	F	E
SB Exit 3 Off-Ramp	D	C	F	E

Northbound Exit 3 On-Ramp to Exit 4 Off-Ramp

I-295 northbound between Exits 3 and 4 is one of the highest volume two-lane segments of Interstate highway in Maine. The 2002 AADT was approximately 38,000 vehicles per day, with AM peak-hour traffic volumes of 3600 vehicles per hour. Due to the limited highway capacity, the inadequate acceleration and deceleration lengths of the ramps, and the high volume of weaving and non-weaving traffic, this location is now often congested during the AM peak period and operates at level of service E.

Based on the analysis, a Type A weave (see Figure 2.13) would be effective. This includes construction of a northbound auxiliary lane along the right shoulder of I-295 between Exits 3 and 4. The addition of the auxiliary lane would relieve the capacity constraints (Table 4.4) at this location, increase the effective acceleration and deceleration lengths of the ramps, improve the efficiency of weaving traffic movements, and improve the level of service. Table 4.6 shows that the AM peak hour LOS would improve with a Type A weave from F to E, and in the PM peak it would improve from E to D.

Table 4.6: 2025 NB Exit 3-to-4 LOS Impacts with Auxiliary Lane Improvements

	2025 AM No-Build	2025 AM Type A Weave	2025 PM No-Build	2025 PM Type A Weave
NB Exit 3 On-Ramp	D	C	F	E
NB Exit 3 to Exit 4	D	C	F	E
NB Exit 4 Off-Ramp	D	C	F	E

Northbound Exit 6 On-Ramp to Exit 7 Off-Ramp

This location currently has a northbound weave (Type A) section between the Exit 6 on-ramp and the Exit 7 off-ramp. Vehicles entering I-295 from Exit 6 and vehicles exiting I-295 at Exit 7 both have to make lane changes. The terminus of the northbound Exit 7 off-ramp (where it meets with the Exit 7 southbound off-ramp) contributes to the problem. This area becomes congested (especially in the AM peak) to the point where vehicles queue up on both off-ramps and encroach on the I-295 mainline. Routinely, northbound off-ramp traffic queues up side-by-side on the one-lane ramp. Also, as shown in Table 3.3, 2025 demand in this area is expected to exceed baseline highway capacity.

Based on the analysis a Type B weave (see Figure 2.13) would be effective. As shown in Figure 4.2, this includes construction of a second lane for the Exit 7 northbound off-ramp. Improvements also include adding a signal at the intersection of the two off-ramps. The addition of a two lane off-ramp would relieve the capacity constraints (Table 4.4) at this location, improve the efficiency of weaving traffic movements, improve safety, and improve the level of service. I-295 northbound vehicles using Exit 7 would no longer need to make a lane change. (Only entering traffic would.) Table 4.7 below shows the AM peak hour LOS would improve from E to D (Type A weave to a Type B weave), and in the PM peak it would improve from F to E.

Figure 4.2: Exit 7 Conceptual Improvement Plan (enlarged in Appendix 23)



Table 4.7: 2025 NB Exit 7 LOS Impacts with Auxiliary Lane Improvements

	2025 AM No-Build (Type A)	2025 AM Type B Weave	2025 PM No-Build (Type A)	2025 PM Type B Weave
NB Exit 6 On-Ramp	E	C	F	E
NB Exit 6 to Exit 7	E	C	F	E
NB Exit 7 Off-Ramp	E	C	F	E

Southbound Exit 8 to Exit 7 Off-Ramp

I-295 southbound between Exits 8 and 7 has an AADT of approximately 34,000 vehicles per day, with AM peak-hour traffic volumes that approach 4000 vehicles per hour. A problem area is the short two-lane cross-section on the southbound mainline between Exit 8 and the Exit 7 off-ramp. Another problem is the single-lane off-ramp at Exit 7. The unsignalized junction of the northbound and southbound ramps becomes congested (especially in the AM Peak) to the point where vehicles queue up on both ramps and, in the northbound direction, encroach on the I-295 mainline.

Based on the analysis, a Type B weave (see Figure 2.13) would be effective. As shown in Figure 4.2, this includes construction of an auxiliary lane to eliminate the southbound two-lane constriction between Exit 8 and Exit 7 and a second lane for the Exit 7 southbound off-ramp. Improvements also include adding a signal at the intersection of the two Exit 7 off-ramps. These improvements would relieve the capacity constraints (Table 4.4) at this location, improve the efficiency of weaving traffic movements, improve safety, and improve the level of service. Table 4.8 below shows the AM peak hour LOS would improve from F to E (Type B weave), and in the PM peak it would improve from D to C.

Table 4.8: 2025 SB Exit 7 LOS Impacts with Auxiliary Lane Improvements

	2025 AM No-Build	2025 AM Type B Weave	2025 PM No-Build	2025 PM Type B Weave
SB Exit 8 to Exit 7	F	E	D	C
SB Exit 7 Off-Ramp	F	E	D	C

Exit 7 and especially the southbound off-ramp of Exit 7 are close to the pedestrian/bicycle trail around Back Cove. Auxiliary lane improvements in this area should consider the need to maintain the integrity of the trail and accommodate the needs of pedestrians and bicyclists, while meeting the safety and efficiency needs of Exit 7.

2. Acceleration/Deceleration Lanes

In the rural portion of I-295 north of Portland, several potential locations for extensions to on-ramp acceleration lanes and off-ramp deceleration lanes were identified at interchanges from Falmouth to Freeport.

Acceleration Lanes

Appendix 7 and Appendix 8, respectively, include diagrams of the 2025 AM and PM peak design hour volumes and the level of service (future auxiliary lane strategy) for the Study Area. Table 4.9 below is a summary of the 2025 auxiliary lanes LOS for the Corridor for extending the acceleration lanes at on-ramps. In comparison with the future No-Build, extension of the acceleration lanes would improve the level of service.

Table 4.9: 2025 LOS Impacts with Acceleration Lane Improvements

	2025 AM No-Build	2025 AM Accel. Lane Extensions	2025 PM No-Build	2025 PM Accel. Lane Extensions
NB Exit 11 On-Ramp	C	B	E	D/C
NB Exit 17 On-Ramp	C	B	D	C/D
NB Exit 20 On-Ramp	B/C	B	E/D	D
NB Exit 22 On-Ramp	B/C	B	E/D	D/C
NB Exit 24 On-Ramp	C/B	B	E	D/C
SB Exit 22 On-Ramp	D	C	C	B
SB Exit 20 On-Ramp	D	C	D/C	C
SB Exit 17 On-Ramp	D	C	C	C
SB Exit 15 On-Ramp	E	D	D	C
SB Exit 10 On-Ramp	D	C	B	B

Deceleration Lanes

Appendix 7 and Appendix 8, respectively, include diagrams of the 2025 AM and PM peak design hourly volumes and the level of service (future auxiliary lane strategy) for the Study Area. Table 4.10 below is a summary of the 2025 auxiliary lanes LOS for the Corridor for extending the deceleration lanes at off-ramps. In comparison with the future No-Build, extension of the deceleration lanes would improve the level of service.

Table 4.10: 2025 LOS Impacts with Deceleration Lane Improvements

	2025 AM No-Build	2025 AM Accel. Lane Extensions	2025 PM No-Build	2025 PM Accel. Lane Extensions
NB Exit 10 Off-Ramp	B	B	E/D	D
NB Exit 15 Off-Ramp	C	B	E	D/E
NB Exit 17 Off-Ramp	B	B	D	D
NB Exit 20 Off-Ramp	C	B	D/E	D
NB Exit 22 Off-Ramp	B/C	B	E	D
SB Exit 24 Off-Ramp	C/B	B	E	D
SB Exit 20 Off-Ramp	D	D	C	C
SB Exit 17 Off-Ramp	D	C/D	C	C
SB Exit 15 Off-Ramp	D	D/C	C/D	C
SB Exit 11 Off-Ramp	E	D	D	C

In most locations, extending the acceleration and deceleration lanes to current standards improves the operational effect, safety and level of service. However, extending the ramps does not add capacity. In comparison auxiliary lanes between ramps improve both capacity and level of service. It must also be mentioned that some of the extensions of acceleration and deceleration lanes may not be applicable if new interchange improvements (see Interchange Improvements) are to be made at Exit 10 (new southbound on-ramp) and Exit 15 (new northbound off-ramp and relocated southbound on-ramp).

3. Remaining Capacity Constraints

In reference to Figure 4.1, even with the auxiliary lane improvements, there would still be five locations with a capacity deficiency and a level of service F.

- Northbound Exit 5 to Exit 6
- Northbound Exit 7 to Exit 8
- Northbound Exit 8 to Exit 9
- Southbound Exit 6
- Southbound Exit 5 to Exit 4

For these locations, auxiliary lanes would either not be feasible or be cost-prohibitive; measures other than the relatively low-cost strategy of auxiliary lanes would be needed to address them. Such strategies might include increased highway capacity, interchange improvements, transportation demand management (TDM), commuter transit, or a combination of strategies.

C. Intelligent Transportation Systems

Intelligent Transportation Systems (ITS) has been defined as the application of advanced sensor, computer, electronics, and communications technologies and management strategies – in an integrated manner – to increase the safety and efficiency of the surface transportation system. In other words, ITS is using the best tools available to help our existing transportation facilities work better.

For I-295, ITS means what is known in many places as a Freeway Management System, but for Maine’s highway terminology, it might be called an Interstate Highway Management System (IHMS). An IHMS would encompass I-295, I-95, and other similar highways with full control of access. A cost-effective IHMS would be planned and designed using a systems engineering approach, from a concept of operations, to implementation, maintenance and operations, and operations assessment. Essential elements of an IHMS would include traffic monitoring, motorist information, incident response, and a control center.

1. Traffic Monitoring

Traffic monitoring provides the real-time information needed to assess the current performance of the highways in the system. Full time detection of traffic volumes and speeds provides the information needed to detect incidents and other problems on the highway. It also provides traffic data that can be used for highway planning purposes. Traffic monitoring is most effective when sensors are located on each highway segment between ramps and on the ramps themselves. In addition to sensors for traffic volumes and speeds, video monitoring can be used to obtain live images of operations at key locations on the highway.

In the Greater Portland area, traffic monitoring equipment is permanently installed on all mainline segments of I-95 (the Maine Turnpike) and its interchange ramps, currently for use in historical data collection. The Maine Turnpike Authority also has a limited number of video installations at select locations to monitor real-time conditions. Currently, I-295 has only two mainline segments where continuous traffic volume data is collected. For rapid detection of traffic incidents, full instrumentation is needed. This need on I-295 can be met most effectively by upgrading traffic monitoring capabilities between I-95 Exit 44 and I-295 Exit 11, as shown by the dashed line in Figure 4.3. This portion of I-295, along with the parallel facilities of the Maine Turnpike on I-95 and the Falmouth Spur, has the highest volumes and the greatest opportunities for effective traffic management.

2. Motorist Information

Means of transmitting real-time information to motorists are necessary to ensure that motorists have data needed to make timely transportation decisions. Two common ways of communicating current information to motorists is through variable message signing and highway advisory radio.

The Maine Turnpike Authority has variable message signs at select locations and operates a highway advisory radio service to advise motorists of conditions on the Maine Turnpike. Two signs are strategically located at points where through traffic chooses whether to use I-295 or I-95 to get across Portland: I-295 southbound north of Exit 11 and I-95 northbound south of Exit 44 (the starting point of I-295). These sign locations can be supplemented by additional variable message sign installations at critical locations along I-295. Two such locations are I-295 southbound north of Exit 9 and I-295 northbound south of Exit 4. The two existing and two potential sign locations discussed above are shown by arrow in Figure 4.3.

3. Control Center

A control center is necessary to process the information coming from the highway, dispatch information to responders, and communicate conditions to motorists. The control center must operate through lines of communications and protocols established jointly among the agencies that will make the management system work.

In the I-295 Corridor, the Maine Department of Transportation, the Maine Turnpike Authority, the Maine State Police, and local and regional government entities have a role in an IHMS. All of these agencies currently have control functions for dealing with situations on all or part of the Interstate highway network, but these functions are not fully integrated. These agencies would plan, design, and establish a control center that manages the network in a comprehensive manner.

4. Service Patrols

Service patrols can be an effective tool for managing highway incidents. This service, which involves vehicles and personnel dedicated to patrolling a highway to resolve incidents quickly and effectively, can help identify incidents and be the responder for those incidents that do not require emergency response. Such incidents would include stalled vehicles, vehicles with flat tires, or debris in the roadway. Service patrols can shorten the duration of incidents, allow emergency responders to be more available for emergency tasks, and provide much-appreciated help to motorists in trouble. As part of an IHMS, service patrols can identify and verify traffic incidents and report them to the control center for further actions, as appropriate.

Service patrols have been instituted on the Maine Turnpike, but they have not yet been used on I-295. With high traffic volumes and thousands of incidents per year, the 28 miles of I-295 from Scarborough to Brunswick would be a logical candidate for such patrols.

Figure 4.3: Potential ITS Installations



D. Transportation Demand Management

Transportation Demand Management (TDM) is the use of low-cost actions to modify travel behavior by encouraging people to share rides, telecommute, use transit, or change their travel route.

1. Carpool

As indicated in Section II D, Existing Conditions, carpool facilities and services exist in the I-295 Corridor and throughout Maine. However, journey-to-work data from the U.S. Census reports that 90% of the commuters to Portland drive alone. This means that less than 5% of commuter vehicles have two or more workers, even though carpooling reduces the per person costs of fuel and parking. The Go Maine program has instituted policies and actions such as emergency rides home, pre-tax commuter choices, education and promotion, and vanpool driver training. To encourage more carpooling in the I-295 Corridor, additional measures may be needed to create an added incentive.

Economic incentives to carpool could increase the rate of carpooling. These economic incentives could include policies that create a cost differential between vehicles used by single occupants and vehicles used for carpooling. Such policies could include a higher parking charge or per mile cost for single-occupant vehicles (SOVs). For example, a cost differential that results in \$0.75 per mile can increase use of high-occupancy vehicles (HOVs) to 70% of the commuters using carpools, vans, or buses.

2. High Occupancy Vehicle Lanes

High Occupancy Vehicle (HOV) lanes are travel lanes on a roadway reserved for use only by vehicles with more than a single occupant. HOV lanes may be reserved for buses only or buses and vans only, but usually HOV lanes may be used by any passenger vehicles with two or more, or three or more, occupants. The purpose of an HOV lane is to encourage more efficient use of the highway by providing the incentive of a free-flowing travel lane for vehicles with two or more occupants. This incentive would encourage more carpooling, vanpooling, and use of transit. For the purposes of evaluating the potential of HOV lanes in the I-295 Corridor, any vehicles with two or more occupants would be able to use an HOV lane.

For the HOV evaluation, four options were considered:

- Two general-purpose travel lanes in each direction, as I-295 exists today.
- One general-purpose travel lane and one HOV lane in each direction. The travel lane adjacent to the highway median would be converted to HOV use.
- Two general-purpose travel lanes and one HOV lane in each direction. An added travel lane is provided in each direction. The lane closest to the median is designated as an HOV lane.
- Three general-purpose travel lanes in each direction. An added travel lane is provided in each direction with no restrictions based on the number of occupants.

The first three out of these four options are illustrated in Figure 4.4. The diamond symbol is a pavement marking used to identify HOV travel lanes. The arrows represent flows of through traffic (pink), on-ramp traffic (blue), and off-ramp traffic (red).

Figure 4.4: HOV Option Configurations

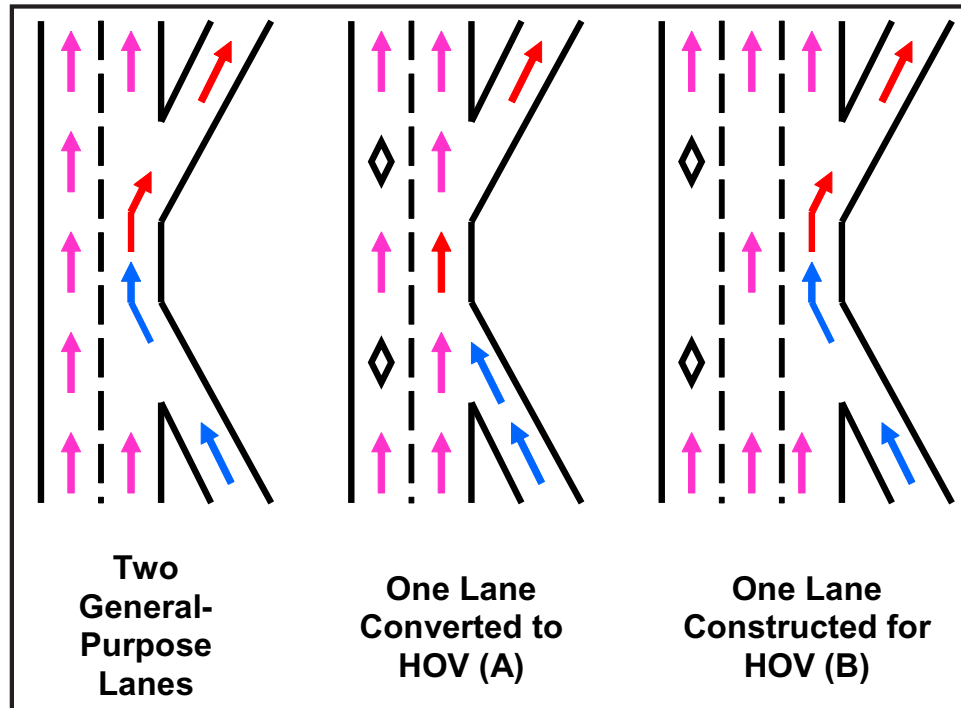

Each of the four options was evaluated using forecasted PM peak-hour travel volumes at Mile 13 northbound (in Cumberland) for year 2025. The performance results of these four options are summarized in Table 4.11.

With the existing configuration, Mile 13 northbound on I-295 would operate at LOS E during the PM peak hour. Both lanes would be used approximately equally with travel speeds between 55 and 60 mph and over 90% of the available capacity being used.

Conversion of the median lane to HOV use (HOV A) would have a noticeable impact on performance. The HOV lane would operate at LOS C and carry nearly 40% of the vehicles and about 60% of the people. The HOV lane would get over 300 drivers out of their single occupant vehicles. Speeds in the HOV lane would be nearly at the free flow speed of 70 mph, and the lane would operate at two-thirds of its vehicular capacity. Unfortunately, the general-purpose lane would be operating beyond its vehicular capacity, resulting in very low speeds and LOS F. Overall speeds for this option would be near 20 mph, still at LOS F overall. With such differences in speed between the two lanes, lane changing would be an unwanted safety issue.

Construction of an added HOV lane (HOV B) along side the two existing general-purpose lanes would have dramatically different results compared to conversion of an existing general-purpose lane. Speeds in all lanes would be nearly free flowing with LOS C. The HOV lane would carry 30% of the vehicles and 50% of the people. However, the two general-purpose lanes would operate as freely as the HOV lane. In essence, it would perform as freely as a configuration with three general-purpose lanes (GP C). Any incentive to use the HOV lane would be lost because there would be virtually no speed advantage. The addition of a third lane, whether HOV or general-purpose, might even encourage more travelers to use single-occupant vehicles.

In summary, the HOV lane does not offer a practical solution to congestion on I-295. Conversion of an existing lane to HOV use would result in worse traffic congestion than the existing general-purpose configuration. Construction of a new HOV lane would improve capacity and operations on I-295, but offer no more incentive to use high-occupancy vehicles than would the addition of a third general-purpose lane.

Table 4.11: Performance Comparison of HOV Options

Performance of HOV Alternatives at Mile 13 NB in 2025 Peak Hour					
Performance Measure	Units	Existing	HOV A	HOV B	GP C
General Purpose Lanes	#	2	1	2	3
HOV Lanes	#	0	1	1	0
Capacity in GP Lanes	veh/hr	4035	2018	4035	6053
Capacity in HOV Lane	veh/hr	0	2018	2018	0
Volume in GP Lanes	veh/hr	3883	2220	2770	3898
Volume in HOV Lane	veh/hr	0	1352	1128	0
Change in Volume	veh/hr	-	-311	+15	+15
Persons in GP Lanes	pers/hr	5540	2220	5540	5540
Persons in HOV Lane	pers/hr	0	3320	0	0
Speed in GP Lanes	mph	57	9	69	69
Speed in HOV Lane	mph	-	69	-	-
Overall Speed (Persons)	mph	57	19	69	69
LOS in GP Lanes		E	F	C	C

3. Toll Adjustments

Another TDM action that can change driver behavior is the use of tolls to encourage use of one highway route over another. The I-295 Corridor offers opportunities to use differential tolls to redirect current I-295 traffic toward using an alternate route such as I-95 (the Maine Turnpike). The most promising opportunity may lie in the I-295 Corridor between Scarborough and Falmouth, as shown in Figure 4.5. Through traffic between Scarborough (and points south) and Falmouth (and points north) may choose to travel I-295 or I-95 (the Maine Turnpike). Currently, drivers have the choice between using I-295 and using the Falmouth Spur and I-95.

Either way, the basic passenger car toll is now the same. The toll for using I-295 is levied at Maine Turnpike Exit 44 in Scarborough. The toll for using I-95 is levied on the Falmouth Spur (I-95 Exit 52). There are drivers using I-295 that could be using the Maine Turnpike, but there is no financial incentive to direct traffic to one route vs. another. The necessary financial incentive could come from a differential toll that makes one route preferred over another.

Figure 4.5: Differential Toll Routes

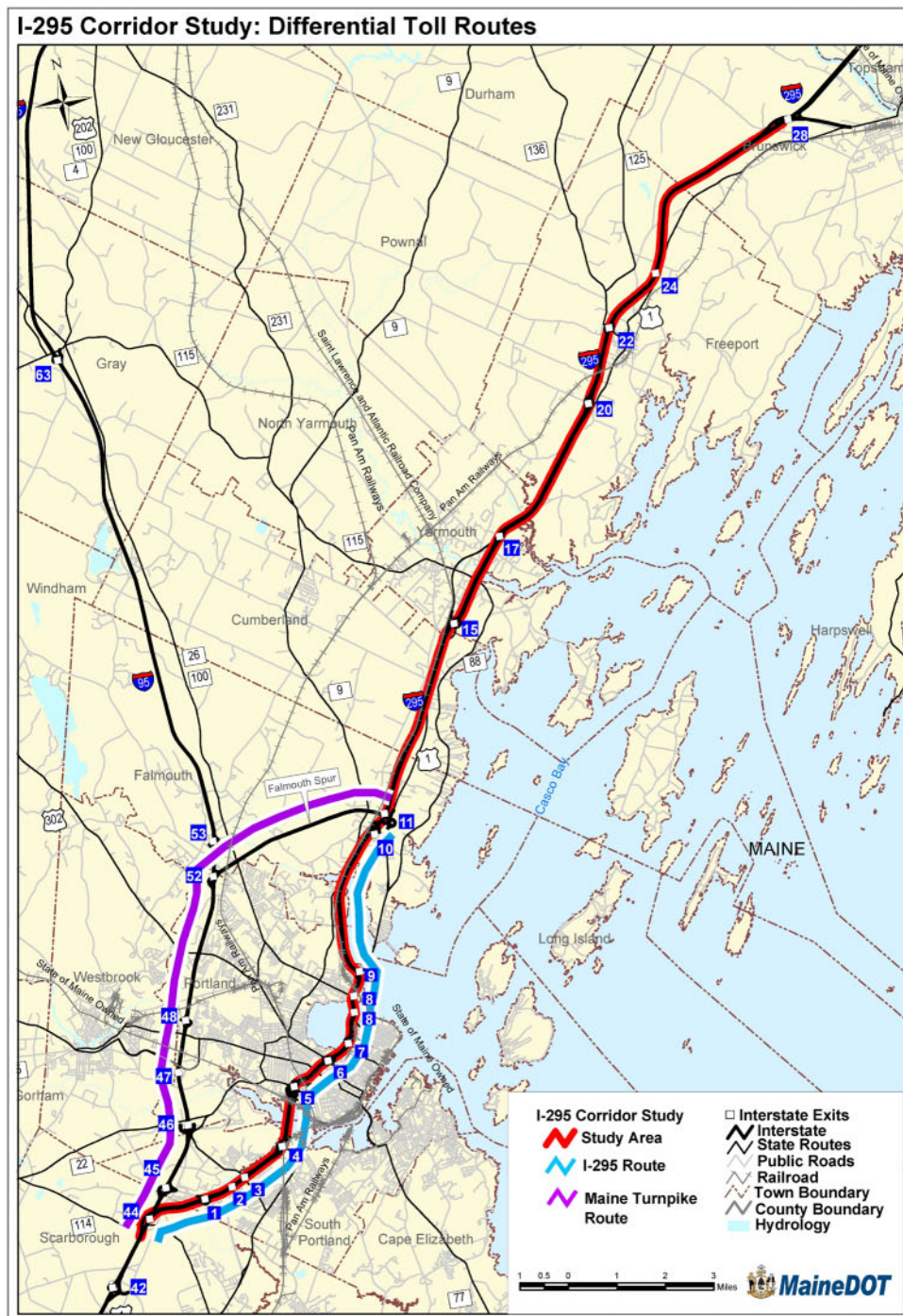

The aim of the differential toll evaluation was to determine if a differential toll could effectively reduce traffic volume and congestion on I-295. A differential toll can be created by reducing or increasing tolls on the two competing routes. The objective is to create enough financial incentive to encourage through traffic to use the Maine Turnpike and not I-295. A range of differential tolls were tested through use of the PACTS travel demand model to measure their effectiveness in diverting through traffic. The results are summarized in Table 4.12.

Table 4.12: Effect of Differential Tolls on 2025 PM Peak Hour Use of I-295 in Portland and South Portland by Through Traffic

Toll Differential (2006 dollars)	0.00	0.30	0.60	0.90	1.20
Through Traffic Volume on I-295	545	473	457	406	277
% of Through Traffic on I-295	67%	58%	56%	50%	34%

As Table 4.12 shows, higher differential tolls result in higher diversions of through traffic away from I-295. Of the differential tolls tested, the \$1.20 toll differential had the largest effect. For the purposes of the analysis, the diversion effects of a \$1.20 toll differential were used in evaluation of levels of service and other performance measures of actions of this alternative.

Appendix 18 and Appendix 19, respectively, include diagrams of the 2025 AM and PM peak design hour volumes and the level of service, comparing high differential tolls on the Maine Turnpike and I-295 between Scarborough and Falmouth (combined with the auxiliary lanes strategy on I-295) to baseline (No-Build) for the Study Area. Table 4.13 is a summary of the levels of service for the Study Area during the 2025 AM Peak. In comparison with the AM peak with auxiliary lanes (Table 4.2), the differential toll (Table 4.13) could reduce the number of LOS E's from 15 to 6.

Table 4.13: 2025 Differential Toll w/ Auxiliary Lanes on I-295 LOS AM Peak

		2002 Level of Service AM Peak					
		A	B	C	D	E	F
On/Off Ramps	Southbound	0	7	13	9	3	0
	Northbound	2	19	3	9	0	0
Segments Between On/Off Ramps	Southbound	2	4	5	6	3	0
	Northbound	3	11	2	5	0	0

Table 4.14 below shows the baseline volumes and the new volumes (resulting from the redirection of traffic because of the differential toll) for the 15 locations where the auxiliary lane strategy would result in LOS E during the AM peak. The locations where LOS would remain E are southbound between Exits 9 and 8, southbound between Exits 8 and 7, and southbound in the weave area at Exit 6.

Table 4.14: 2025 AM Peak Differential Toll

				Differential Toll w/Aux. Lanes	
	2025 AM Volume	2025 AM No-Build	2025 AM Aux. Lns.	2025 AM Volume	2025 AM
NB Exit 3 On-Ramp	755	F	E	602	D
NB Exit 3 to Exit 4	4560	F	E	4256	D
NB Exit 4 Off-Ramp	1555	F	E	1419	D
NB Exit 5 Off-Ramp	649	E/D	E/D	663	D
SB Exit 9 On-Ramp	825	E	E	895	D/E
SB Exit 9 (Weave Area)	4228	E	E	4015	D/E
SB Exit 9 Off-Ramp	349	E	E	223	D/E
SB Exit 9 to Exit 8	3879	E	E	3792	E/D
SB Exit 8 to Exit 7	4769	F	E	4569	E
SB Exit 7 Off-Ramp	1541	F	E	1560	E
SB Exit 7 to Exit 6	3760	E	E	3599	D
SB Exit 6B Off-Ramp	401	E/D	E/D	406	D
SB Exit 6B On-Ramp	324	E	E	397	E
SB Exit 6 (Weave Area)	3683	E	E	3590	E
SB Exit 6A Off-Ramp	802	E	E	934	E

Table 4.15 is a summary of the levels of service for the Study Area during the 2025 PM Peak. In comparison with the PM peak with auxiliary lane (Table 4.3), the differential toll (Table 4.15) could reduce the number of LOS E's from 25 to 16 and could reduce the number of LOS F's from 9 to 5.

Table 4.15: 2025 Differential Toll w/ Auxiliary Lanes on I-295 LOS PM Peak

		2025 Differential Toll Aux. Lanes LOS PM Peak					
		A	B	C	D	E	F
On/Off Ramps	Southbound	2	9	9	8	2	2
	Northbound	1	2	7	14	8	1
Segments Between On/Off Ramps	Southbound	2	6	6	4	1	1
	Northbound	1	2	4	8	5	1

Table 4.16 shows the baseline volumes and the new volumes (resulting from the redirection of traffic because of a high differential toll) for the 34 locations where the auxiliary lane strategy would result in LOS E or F during the PM peak. For 20 of the 34 locations, the LOS would remain E or F after implementation of a differential toll. The LOS at 11 locations would improve to D or C. For the northbound Exit 6A off-ramp, northbound between Exit 8 and 9, southbound Exit 5A on-ramp, and southbound Exit 4 off-ramp, the LOS would improve from F to E. The LOS would remain at F at the southbound Exit 6 weave area, at the northbound Exit 7 on-ramp, and between northbound Exits 7 and 8.

Table 4.16: 2025 PM Peak Differential Toll

				Differential Toll w/Aux	
	2025 PM	2025 PM	2025 PM	2025 PM	2025 PM
	Volume	No-Build	Aux. Lns.	Volume	
NB Exit 4 to Exit 5	3643	E	E	3476	D
NB Exit 5 Off-Ramp	631	E/D	E/D	599	D
NB Exit 5 On-Ramp	302	E	E	407	E/D
NB Exit 5 to Exit 6	4056	E	E	3902	E
NB Exit 6A Off-Ramp	335	F	F	408	E
NB Exit 6A On-Ramp	382	E	E	387	E
NB Exit 6 (Weave Area)	4103	E	E	3881	E
NB Exit 6B Off-Ramp	604	E	E	687	E
NB Exit 6B On-Ramp	931	F	E	1063	D
NB Exit 6 to Exit 7	4430	F	E	4257	D
NB Exit 7 Off-Ramp	652	F	E	710	D
NB Exit 7 On-Ramp	1521	F	F	1540	F/E
NB Exit 7 to Exit 8	5299	F	F	5087	F/E
NB Exit 8 On-Ramp	1012	E	E	1057	E
NB Exit 8 (Weave Area)	6311	E	E	6144	E
NB Exit 8 Off-Ramp	2062	E	E	1994	E
NB Exit 8 to Exit 9	4249	F	F	4150	E
NB Exit 9 On-Ramp	359	E	E	233	E/D
NB Exit 9 (Weave Area)	4608	E	E	4383	E/D
NB Exit 9 Off-Ramp	1035	E	E	1105	D/E
NB Exit 10 to Exit 11	3219	E	E	1959	B
NB Exit 11 to Exit 15	3883	E	E	3530	D
SB Exit 7 to Exit 6	3603	E/D	E/D	3397	D
SB Exit 6B On-Ramp	599	F	F	635	F
SB Exit 6 (Weave Area)	3956	F	F	3806	F
SB Exit 6A Off-Ramp	675	F	F	813	F
SB Exit 6A On-Ramp	606	E/D	E/D	669	D
SB Exit 6 to Exit 5	3887	E	E	3662	E/D
SB Exit 5A On-Ramp	494	F	F	528	E/D
SB Exit 5 to Exit 4	4230	E/F	E/F	4065	D
SB Exit 4 Off-Ramp	785	F	F	787	E
SB Exit 4 On-Ramp	1535	F	E	1399	D/E
SB Exit 4 to Exit 3	4980	F	E	4677	D/E
SB Exit 3 Off-Ramp	1265	F	E	1112	D

The differential toll evaluation shows that this type of action can reduce volumes and improve levels of service on I-295. The evaluation also shows that some I-295 ramps could see increased use because the removal of through traffic would allow more local traffic to use

I-295. It should be noted, however, that numerous combinations of toll increases, reductions, or tolling locations are possible, and their effectiveness at improving mobility on the transportation network may vary.

Important considerations in the possible implementation of differential tolls include the following:

- Regulatory limitations on where tolling could be implemented. Currently, tolls can only be levied on the Maine Turnpike.
- The potential impact of differential tolling on the traffic and toll revenue impacts to the Maine Turnpike. The Maine Turnpike Authority has financial responsibilities to maintain the highway and fund improvements.
- The traffic impacts to arterial and collector streets near toll booths or interchanges.
- The technical issues of designing a differential toll system that will not create unintended toll-avoidance travel behavior such as a traffic shift from I-95 Exit 44 to Exit 45.
- The impact that electronic toll collection technologies and open-road tolling can have on the feasibility of differential tolls.

In addition to the evaluation of differential tolls between Falmouth and Scarborough, differential tolls between Augusta and Portland were examined to evaluate the potential of toll adjustments to redirect long-distance travel from the I-295 route to the I-95 (Maine Turnpike) route. Unlike the Falmouth-Scarborough routes, which currently have equal tolls, the Augusta-Portland routes already has a toll differential which encourages use of toll-free I-295 as the most-favored route between the two cities. Based on 2007 toll rates, the toll for using I-95 between the cities was \$1.05 more for passenger cars (\$4.20 more for large trucks) than the toll for using I-295. The I-295 route is also the shorter distance, with normally shorter travel times between Augusta and Portland. The I-95 route has a higher allowable weight limit for heavy trucks.

Nevertheless, the *I-295 Through Traffic Study*, conducted for MaineDOT and the Maine Turnpike Authority, found that a doubling of the I-295 toll could shift about 10% of the long-distance through traffic using I-295 to the I-95 route. However, long-distance through traffic represents only about 3% of the I-295 peak-hour traffic in Portland and South Portland, so the long-distance toll change would produce only a minimal traffic diversion in the heavily traveled I-295 Corridor.

E. Commuter Transit

The commuter transit strategy of this study includes alternatives for providing express mass transportation to the Portland Peninsula. The alternatives focus on a market area that is served by the I-295 Corridor, both from the north and the south. For the purposes of this Study, the market area includes 56 communities in York, Cumberland, Androscoggin, and Sagadahoc Counties that would be home to residents who would commute to Portland by way of I-295 (and I-95 in York County). According to journey-to-work data from the 2000 Census, 13,000 workers commute to the Portland Peninsula from these 56 communities.

Of those 13,000 workers, 81% leave for work between 5 AM and 9 AM. This time period includes 7 AM to 8 AM peak hour when inbound travel on I-295 is at its highest volume. The purpose of a commuter transit alternative would be to reduce the AM peak inbound and the PM peak outbound traffic volumes to relieve the pressure on highway capacity by attracting Peninsular-bound commuters to a different transportation mode. A commuter transit service may also attract commuters in the off-peak direction or off-peak time period, or travelers on non-work trips.

The commuter transit alternatives analyzed (bus and rail) share some common characteristics. The alternatives analysis considered the following towns and cities as potential locations for commuters boarding transit bound for Portland.

Bath	Auburn	Biddeford
Brunswick	New Gloucester	Saco
Freeport	North Berwick	Old Orchard Beach
Yarmouth	Wells	Scarborough
Falmouth	Kennebunk	

These locations are close to railroads and highways that parallel or connect with the I-295 Corridor, approaching Portland from the north or the south. The Bayside area of Portland, near Marginal Way, was chosen as the Portland Peninsula terminus for commuter transit service because of its close proximity to I-295 and the center of the Portland Peninsula. Figure 4.6 shows the commuter transit corridors analyzed.

A peak-period frequency of service of 30 minutes was chosen for analysis. Census journey-to-work data indicates that most arrivals at work are on the hour or half-hour (7:00, 7:30, 8:00, 8:30, etc.). Of the 10,500 inbound trips beginning between 5 and 9 AM, 43% of those peak trips are likely to begin between 7 and 8 AM.

Figure 4.6: Potential Commuter Transit Corridors

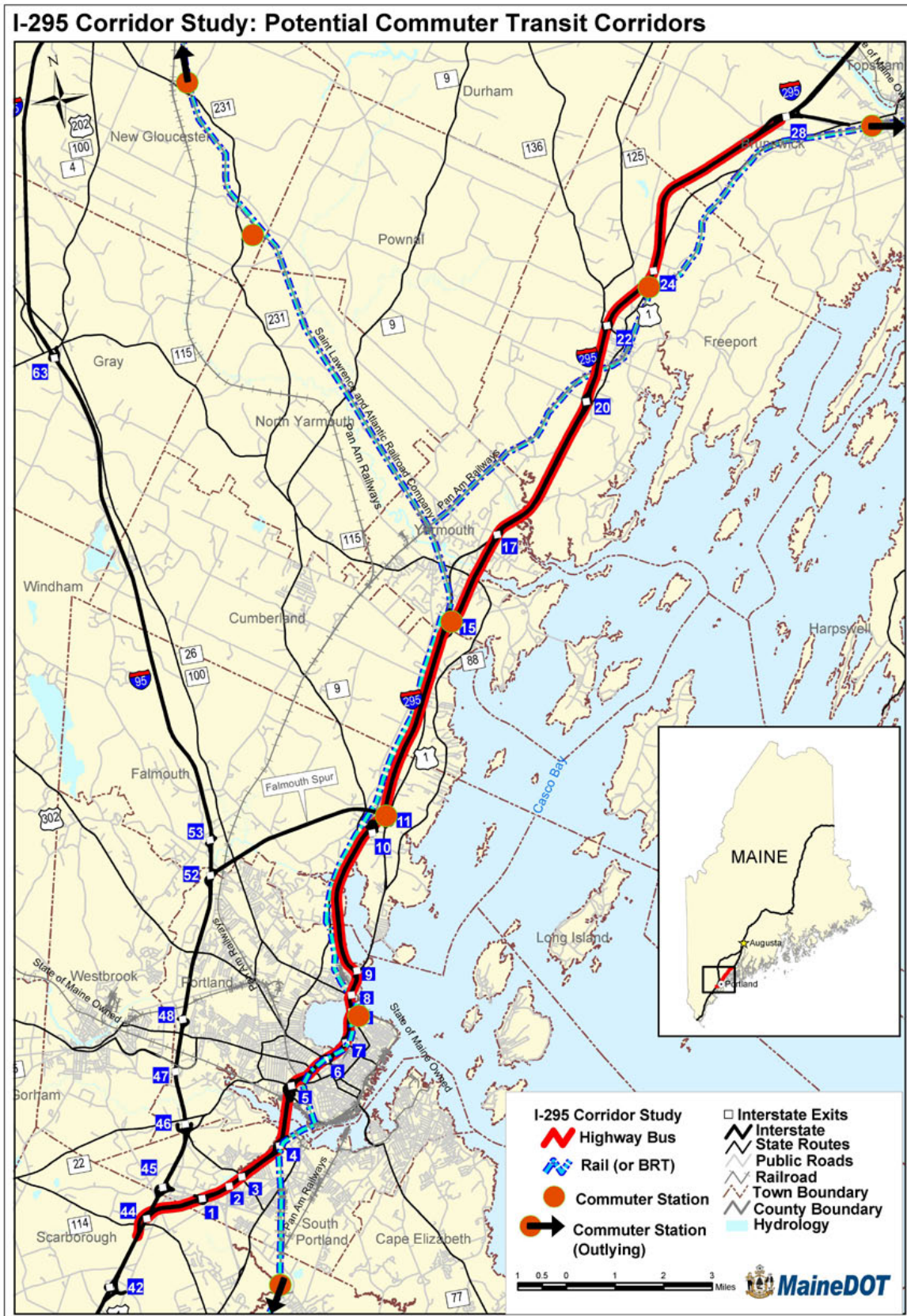

1. Bus

The commuter bus alternative would pick up commuters at designated park-and-ride locations and travel over the existing highway network, including I-295, to Portland. Because I-295 is not a feasible corridor for a dedicated bus lane or high-occupancy-vehicle lane, commuter buses would travel in mixed traffic with other highway vehicles. Commuter buses would be 40-passenger vehicles designed for highway use and make limited scheduled stops at designated park-and-ride locations.

2. Rail

The commuter rail alternative would pick up commuters at park-and-ride locations along the rail corridor. Unlike the commuter bus, the rail vehicle would travel on railroad line, which serves as an exclusive guideway, separated from highway traffic. The commuter rail vehicle would either be one or more self-propelled rail passenger cars or a locomotive pulling (or pushing) a series of rail passenger cars. Typical passenger cars might have a capacity of approximately 90 passengers. The commuter rail service would stop at designated stations along the line to the Portland Peninsula.

Another commuter mode of mass transit not explicitly evaluated in this Study is bus rapid transit, which requires the availability of an exclusive guideway for most of its route. The exclusive guideway gives bus rapid transit some of the performance characteristics of rail transit.

3. Ridership

Estimates of transit ridership were made for the AM and PM peak periods of commuter travel for both bus and rail modes of transit in 2025, taking into account projected job growth in the Portland Peninsula. It was assumed that either commuter bus or commuter rail service would be available, but not both modes in competition with each other. A sensitivity analysis of commuter ridership estimates was made using a range of values for several factors such as frequency of service, average highway speed, parking costs, etc. (See Appendix 22.)

The analysis resulted in 2025 peak-period inbound estimates of commuter ridership for the bus and rail alternatives, as shown in Table 4.17. These estimates do not include off-peak commuters or non-work riders using the transit service. Both transit modes attracted approximately equal numbers of commuters from the north as from the south. From the north, Brunswick, Freeport, Yarmouth, and Falmouth showed promise as boarding locations for the service. From the south, Biddeford, Saco, Old Orchard Beach, and Scarborough are promising. Commuters from beyond Brunswick and Biddeford were fewer in number, but could take advantage of the commuter service by boarding at those locations.

Table 4.17: Estimated Inbound Peak-Period Commuter Transit Ridership in 2025

	Park & Ride Station	Commuter Mode	
		Bus	Rail
North of Portland	Brunswick	28	54
	Freeport	33	51
	Yarmouth	83	120
	Falmouth	152	211
	Total from North	296	436
	Total to Portland	581	841
South of Portland	Total from South	285	405
	Scarborough	120	150
	Old Orchard Beach	31	46
	Saco	108	158
	Biddeford	26	51

Table 4.17 also shows that in 2025 commuter rail service could attract more commuters than a comparable commuter bus service. The sensitivity analysis of the two indicated that automobile travel time to the Peninsula would have different impacts on the ridership of the two transit modes.

As travel time by automobile increases from 2002 base conditions, commuter rail attracts a greater number of Portland-bound commuters. With increasing traffic volumes, would come increasing traffic congestion, slower highway speeds, and longer travel times for highway users. Because rail transit would operate on its own exclusive guideway, commuter rail travel times would be unaffected by highway congestion. Therefore, with increasing highway congestion, commuter rail transit would become more and more competitive with commuting by automobile and attract larger numbers of commuters.

In contrast, commuter bus service in mixed traffic could actually lose ridership, with increasing highway congestion. The main reason for this would be the dependence of the commuter bus service on use of general-purpose travel lanes. As travel times by auto increase due to increasing congestion, so too would travel times by bus. The commuter bus in mixed traffic would not improve its competitiveness with the automobile as traffic volumes and congestion increase.

The effects of automobile travel time on these two modes are shown in Figure 4.7. With travel times as they were in 2002, commuter bus in mixed traffic would attract ridership only slightly less than the ridership of commuter rail. However, as travel time by auto increases on the commute to the Portland Peninsula, the gap in ridership widens significantly.

Even so, the bus can have an important role in commuter transit. Commuter bus transit could function as an interim service until commuter rail infrastructure and service could be implemented. Another function of the bus could be as a feeder transit service to commuter rail stations. Also, if an exclusive guideway were to be available, bus rapid transit could be a long-term commuter transit option.

Figure 4.7: Effect of Travel Time by Auto on Commuter Transit Ridership

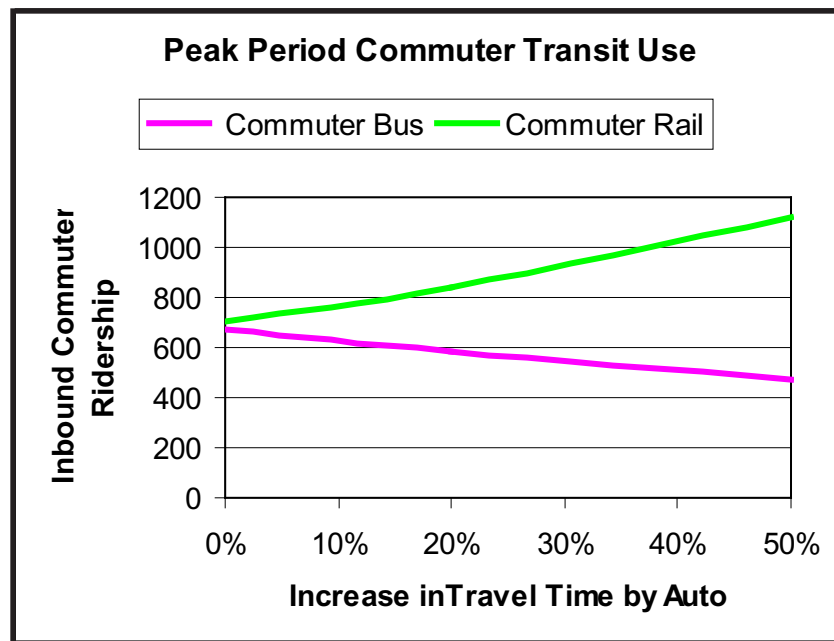

Finally, Figure 4.7 shows the importance of an exclusive guideway to the ability of transit to attract larger numbers of commuters. As highways become more congested, not only do travel times become longer on average, travel times also become less reliable because traffic incidents can constrict highway capacity and cause major traffic delays. On an exclusive guideway, commuter transit provides a consistent, reliable travel time that has virtual immunity to incidents and great capacity for increased usage. A commuter transit mode on an exclusive guideway, of which commuter rail is an example, would be more effective as a long-term solution than would commuter transit in mixed congested traffic.

As for the effect of commuter transit on I-295 levels of service, Tables 4.18 through 4.21 summarize the results. Appendix 20 and Appendix 21, respectively, include diagrams of the 2025 AM and PM peak design hour volumes and the level of service, comparing the commuter rail service (combined with the auxiliary lanes strategy on I-295) to baseline (No-Build) for the Study Area. Table 4.18 is a summary of the levels of service for the Study Area during the 2025 AM peak. In comparison to the AM peak with auxiliary lane (Table 4.2), the commuter rail service (Table 4.18) would reduce the number of LOS E's from 15 to 13.

Table 4.18: 2025 Commuter Rail w/Auxiliary Lanes on I-295 LOS AM Peak

		2025 Commuter Rail w/Aux. Lanes LOS AM Peak					
		A	B	C	D	E	F
On/Off Ramps	Southbound	0	4	16	7	5	0
	Northbound	0	20	4	7	2	0
Segments Between On/Off Ramps	Southbound	1	2	7	5	5	0
	Northbound	1	10	5	4	1	0

Table 4.19 below shows the baseline volumes and the new volumes (resulting from the shift in travelers from automobile to commuter rail) for the 15 locations where the auxiliary lane strategy would result in LOS E during the AM peak. The locations where the LOS would remain E are northbound at Exit 3, southbound at Exit 8 to Exit 7, and southbound in the weave area at Exit 6.

Table 4.20 is a summary of the levels of service for the Study Area during the 2025 PM peak. In comparison to the PM peak with auxiliary lanes (Table 4.3), the commuter rail service (Table 4.20) would reduce the number of LOS E's from 25 to 20 and reduce the number of LOS F's from 9 to 2.

Table 4.19: 2025 AM Peak Commuter Rail

				Commuter Rail w/Aux	
	2025 AM	2025 AM	2025 AM	2025 AM	2025 AM
	Volume	No-Build	Aux. Lns.	Volume	
NB Exit 3 On-Ramp	755	F	E	755	E/D
NB Exit 3 to Exit 4	4560	F	E	4384	E/D
NB Exit 4 Off-Ramp	1555	F	E	1555	E/D
NB Exit 5 Off-Ramp	649	E/D	E/D	649	D
SB Exit 9 On-Ramp	825	E	E	825	E/D
SB Exit 9 (Weave Area)	4228	E	E	4038	E/D
SB Exit 9 Off-Ramp	349	E	E	349	E/D
SB Exit 9 to Exit 8	3879	E	E	3689	E/D
SB Exit 8 to Exit 7	4769	F	E	4579	E
SB Exit 7 Off-Ramp	1541	F	E	1416	E
SB Exit 7 to Exit 6	3760	E	E	3684	E/D
SB Exit 6B Off-Ramp	401	E/D	E/D	401	D/E
SB Exit 6B On-Ramp	324	E	E	315	E
SB Exit 6 (Weave Area)	3683	E	E	3598	E
SB Exit 6A Off-Ramp	802	E	E	737	E

Table 4.20: 2025 Commuter Rail w/Auxiliary Lanes on I-295 LOS PM Peak

		2025 Commuter Rail w/Aux. Lanes LOS PM Peak					
		A	B	C	D	E	F
On/Off Ramps	Southbound	0	7	13	6	6	0
	Northbound	1	2	5	14	10	1
Segments Between On/Off Ramps	Southbound	0	5	9	2	4	0
	Northbound	1	1	2	9	7	1

Table 4.21 shows the baseline volumes and the new volumes (resulting from the shift in travelers from automobile to commuter rail) for the 34 locations where the auxiliary lane strategy would result in LOS E or F during the PM peak. For 27 of the 34 locations, LOS would remain E, and for two locations LOS F, after the addition of commuter rail service. Five locations would improve to LOS D. For northbound Exit 6A off-ramp, northbound between Exit 8 and 9, southbound Exit 6 weave area, southbound Exit 5A on-ramp and southbound Exit 4 off-ramp, the LOS would improve from F to E. The LOS would remain F at the northbound Exit 7 on-ramp and between northbound Exit 7 and 8.

Table 4.21: 2025 PM Peak Commuter Rail

				Commuter Rail w/Aux	
	2025 PM Volume	2025 PM No-Build	2025 PM Aux. Lns.	2025 PM Volume	2025 PM
NB Exit 4 to Exit 5	3643	E	E	3613	D
NB Exit 5 Off-Ramp	631	E/D	E/D	631	D/E
NB Exit 5 On-Ramp	302	E	E	302	E/D
NB Exit 5 to Exit 6	4056	E	E	4026	E
NB Exit 6A Off-Ramp	335	F	F	328	E
NB Exit 6A On-Ramp	382	E	E	382	E
NB Exit 6 (Weave Area)	4103	E	E	4080	E
NB Exit 6B Off-Ramp	604	E	E	604	E
NB Exit 6B On-Ramp	931	F	E	859	E
NB Exit 6 to Exit 7	4430	F	E	4335	E
NB Exit 7 Off-Ramp	652	F	E	639	E
NB Exit 7 On-Ramp	1521	F	F	1403	F
NB Exit 7 to Exit 8	5299	F	F	5099	F
NB Exit 8 On-Ramp	1012	E	E	1012	E
NB Exit 8 (Weave Area)	6311	E	E	6111	E
NB Exit 8 Off-Ramp	2062	E	E	2062	E
NB Exit 8 to Exit 9	4249	F	F	4049	E
NB Exit 9 On-Ramp	359	E	E	359	E/D
NB Exit 9 (Weave Area)	4608	E	E	4408	E/D
NB Exit 9 Off-Ramp	1035	E	E	1035	E/D
NB Exit 10 to Exit 11	3219	E	E	3111	E
NB Exit 11 to Exit 15	3883	E	E	3775	D/E
SB Exit 7 to Exit 6	3603	E/D	E/D	3476	D
SB Exit 6B On-Ramp	599	F	F	539	E
SB Exit 6 (Weave Area)	3956	F	F	3769	E
SB Exit 6A Off-Ramp	675	F	F	664	E
SB Exit 6A On-Ramp	606	E/D	E/D	606	D
SB Exit 6 to Exit 5	3887	E	E	3711	E/D
SB Exit 5A On-Ramp	494	F	F	494	E/D
SB Exit 5 to Exit 4	4230	E/F	E/F	4054	E
SB Exit 4 Off-Ramp	785	F	F	785	E
SB Exit 4 On-Ramp	1535	F	E	1535	E/D
SB Exit 4 to Exit 3	4980	F	E	4804	E/D
SB Exit 3 Off-Ramp	1265	F	E	1265	E/D

F. Interchange Improvements

The interchange improvements strategy includes construction of new ramps at existing interchanges to create full-service four-ramp interchanges and/or major modifications to existing interchanges to address poor traffic operations. The consideration of new interchanges or new locations was beyond the scope of the Study. Four existing interchanges were identified for major improvement considerations: Exit 4 in South Portland, Exit 6 in Portland, Exits 10 & 11 in Falmouth, and Exit 15 in Yarmouth.

1. Exit 4

Exit 4 connects I-295 with Route 1 in South Portland and the Veterans Memorial Bridge into Portland. Even with the auxiliary lane improvements between Exits 3 and 4 discussed in Section IV B, there would still be a deficiency at Exit 4, because it is not a full-service interchange. Vehicles on I-295 northbound are unable to go south on Route 1, and vehicles on Route 1 northbound are unable to go to I-295 southbound. Neither Exit 2 nor Exit 3 have a northbound off-ramp or a southbound on-ramp. In order to use Route 1 or Broadway to get to the Ligonias area, Crocketts Corner, Cash Corner or the Knightville area, I-295 northbound vehicles have to get off at Exit 1 or a Portland exit.

As shown in Figure 4.8, a full-service interchange would include construction of a new northbound off-ramp, converting the two-lane one-way bridge over the I-295 to two-way, and signaling the intersection to allow Route 1 northbound traffic to enter the I-295 southbound on-ramp. Figure 4.8 also shows that Exit 4 is located between Long Creek and a major South Portland industrial area. It should also be noted that bicycle and pedestrian passage through this area serving Portland and South Portland is an important local issue.

Figure 4.8 Exit 4 Improvement Concept (enlarged in Appendix 23)

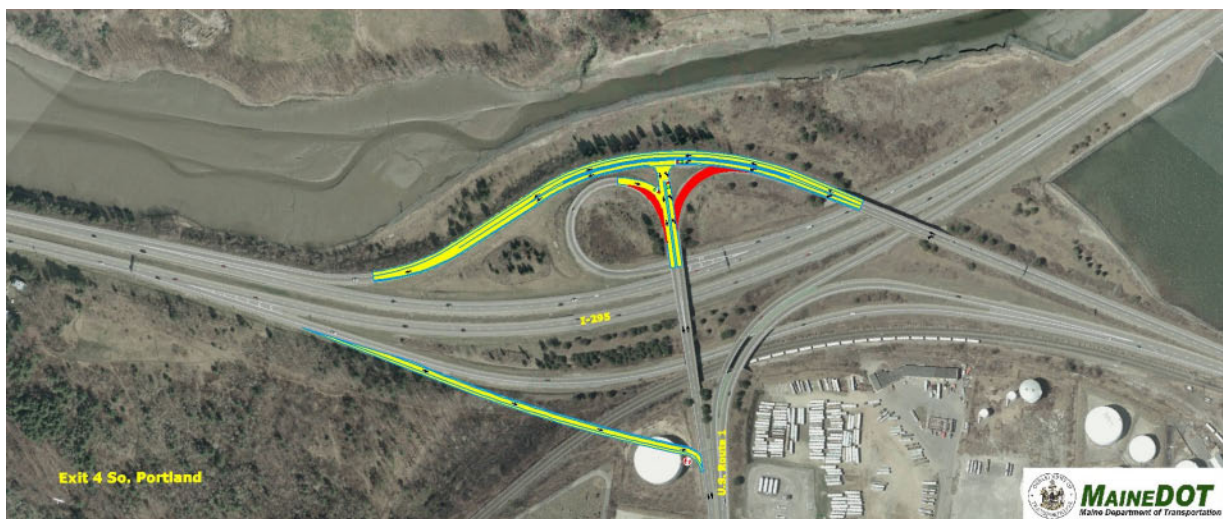

The PACTS travel demand model shows that having a full service interchange would change the traffic pattern. Traffic would decrease on the South Portland connector between the Maine Turnpike and Route 1, on Route 1 and on Broadway; and increase on I-295. Tables 4.22 and 4.23 show that even with these increased volumes around Exit 4, the same level of service could be maintained. For Exit 4 northbound, the level of service would be improved if the off-ramp became two lanes (Type B). Currently the single-lane Exit 4 northbound off-ramp leads only to Veterans Bridge. With the proposed configuration (figure 4.8), the northbound off-ramp would have two destinations (Route 1 southbound and Veterans Bridge). For this reason, a two-lane off-ramp would be a viable option to improve on LOS E during the 2025 AM peak.

Table 4.22: 2025 AM Peak LOS Impact - Exit 4

				Full Service Interchange	
	2025 AM	2025 AM	2025 AM	2025 AM	2025 AM
	Volume	No-Build	Type A	Volume	Type A
NB Exit 3 On-Ramp	755	F	E	819	E
NB Exit 3 to Exit 4	4560	F	E	4817	E
NB Exit 4 Off-Ramp	1555	F	E	1843	E
	2025 AM	2025 AM	2025 AM	2025 AM	2025 AM
	Volume	No-Build	Type B	Volume	Type B
SB Exit 4 On-Ramp	688	D	C	806	C
SB Exit 4 to Exit 3	3169	D	C	3286	C
SB Exit 3 Off-Ramp	1026	D	C	1113	C

Table 4.23: 2025 PM Peak LOS Impact - Exit 4

				Full Service Interchange	
	2025 PM	2025 PM	2025 PM	2025 PM	2025 PM
	Volume	No-Build	Type A	Volume	Type A
NB Exit 3 On-Ramp	1226	D	D	1313	D
NB Exit 3 to Exit 4	3849	E	D	3967	D
NB Exit 4 Off-Ramp	788	E	D	906	D
	2025 PM	2025 PM	2025 PM	2025 PM	2025 PM
	Volume	No-Build	Type B	Volume	Type B
SB Exit 4 On-Ramp	1535	F	E	1823	E
SB Exit 4 to Exit 3	4980	F	E	5238	E
SB Exit 3 Off-Ramp	1265	F	E	1329	E

2. Exit 6

Exit 6 is a very busy interchange connecting I-295 with Forest Avenue in Portland. It serves over 30,000 vehicles per day and over 3000 in the PM peak hour. The interchange is a cloverleaf design with very short weaving sections. Currently, there are long ramp queues, and high crash locations at ramp termini along Forest Avenue, a principal urban arterial. As shown in Appendix 6 (2025 PM No-Build) future volumes will result in a LOS F on I-295 Exit 6 area. As with other interchanges, a key objective is to avoid queuing on the I-295 mainline. The Exit 6 analysis addresses two traffic environments. The I-295 mainline is discussed first, followed by the discussion of Forest Avenue itself.

I-295 Mainline

In each direction, the 2002 AADT was over 38,000 vehicles per day, with PM peak-hour traffic volumes of over 3,200 vehicles per hour in the southbound direction and over 3,500 vehicles per hour in the northbound direction. This location now is congested during peak periods and in the PM peak it operates at a LOS D/E.

Vehicles entering I-295 (northbound or southbound) from Forest Avenue must contend with weaving exit traffic, as well as the high-speed through traffic in the right lane. Likewise, exiting traffic must contend with the on-ramp traffic. Exiting traffic does not have a good opportunity to decelerate because of the short weaving area. Through traffic in the right lane also is affected by the heavy weaving. As shown in Table 4.4, this location is expected to have a future capacity deficit and a LOS F.

A total of seven interchange options were evaluated for Exit 6 to address the long-term deficiencies.

- Cloverleaf – the existing baseline interchange configuration with eight ramps, four of which are loop ramps.
- Collector Distributor – a modification of the cloverleaf that physically separates through traffic from on- and off-ramp traffic.
- Partial Cloverleaf “A” – a six-ramp interchange with two loop on-ramps.
- Partial Cloverleaf “B” – a six-ramp interchange with two loop off-ramps.
- Diamond – a four-ramp interchange with no loop ramps and two at-grade ramp intersections.
- Single-Point Diamond – four-ramp interchange with no loop ramps and one at-grade ramp intersection.
- Median Lanes – an additional lane in each direction, built into the median between Exits 5 and 7.

Table 4.24 shows that the 2025 PM peak hour LOS of each option would be F in the northbound direction except for the median lanes option. The advantage of the median lanes option over partial cloverleaf and diamond options is that it would maintain the eight ramps necessary to accommodate on- and off-ramp traffic, but provide enough mainline width to

create safer separation of through traffic from ramp traffic. The advantage over the collector distributor option is that the median lanes option would fit within the existing I-295 roadway. Figure 4.9 shows the layout of the median lanes option.

Table 4.24: 2025 PM Peak LOS Impact - Exit 6 Alternatives

Option	Northbound	Southbound
Baseline 2025	F	F
Collector Distributor	F	F
PARCLO “A”	F	E/D
PARCLO “B”	F	E/D
Diamond Interchange	F	E/D
SPDI	F	E/D
Median Lanes	D/C	D/E

Figure 4.9: Exit 6 Mainline Improvement Concept (enlarged in Appendix 23)



The PACTS model shows that increasing the number of lanes from Exit 5 to Exit 7 would cause shifts in the traffic patterns. With the additional lanes, traffic would increase in the Exit 6 area, Tukey’s Bridge, the Fore River area, on Franklin Arterial and on Forest Avenue between Park Avenue and Baxter Boulevard. However, traffic would decrease on Park Avenue, Marginal Way, parts of Congress Street and other parts of the Portland Peninsula, the Falmouth Spur, and the Maine Turnpike.

Appendix 10 and Appendix 11, respectively, include diagrams of the 2025 AM and PM peak design hour volumes and the level of service, comparing the median lanes option (six-lanes between Exit 5 and Exit 7, combined with the Auxiliary Lanes Strategy) to Baseline (No-Build) for the Study Area.

In Tables 4.25 through 4.28, even with the additional traffic on I-295, the median lanes option would improve the level of service at the Exit 6 weaving area, and also at Exit 5 and Exit 7.

In Table 4.25 and Table 4.26 (northbound AM and PM Peak) below, the northbound Exit 6A off-ramp LOS would improve from F to C/D. For the Exit 6 weave area, the PM peak LOS would improve from E to D. Between Exit 6 and Exit 7 northbound, the PM peak LOS would improve from F (baseline) to E (auxiliary lanes weave Type B) to C/D with the extra through lane. Currently, there is a weave section between Exit 7 on-ramp and Exit 8. The added through lane would convert this to a merge. The LOS would improve from F to D.

In Table 4.27 and Table 4.28 (southbound AM and PM peak), for the southbound Exit 6 weave area, the PM peak LOS would improve from F to E. Between Exit 8 and Exit 7 southbound, the AM Peak LOS would improve from F (baseline) to E (auxiliary lanes weave Type B) to C/D with the extra through lane. The Exit 5 LOS would also improve.

Table 4.25: 2025 AM Peak NB LOS Impact - Exit 6 Area

Northbound				6-Lane(Aux) Exit 6 Area	
	2025 AM	2025 AM	2025 AM	2025 AM	2025 AM
	Volume	No-Build	Aux.Lanes	Volume	
Exit 5 On-Ramp	305	D	D	391	C
Exit 5 On-Ramp	145	D	D	177	C
Exit 5 to Exit 6	3481	D	D	4043	C
Exit 6A Off-Ramp	366	D	D	590	C
Exit 6A On-Ramp	205	D	D	273	C
Exit 6 (Weave Area)	3320	D	D	3726	C
Exit 6B Off-Ramp	763	D	D	858	C
Exit 6B On-Ramp	666	E/D	D	812	C
Exit 6 to Exit 7	3223	E/D	D	3680	C
Exit 7 Off-Ramp	760	E/D	D	986	C
Exit 7 On-Ramp	351	C/B	C/B	342	B
Exit 7 to Exit 8	2814	C/B	C/B	3036	C/B

Table 4.26: 2025 PM Peak NB LOS Impact - Exit 6 Area

Northbound				6-Lane(Aux) Exit 6 Area	
	2025 PM	2025 PM	2025 PM	2025 PM	2025 PM
	Volume	No-Build	Aux. Lanes	Volume	
Exit 5 On-Ramp	742	D	D	925	C
Exit 5 On-Ramp	302	E	E	399	C
Exit 5 to Exit 6	4056	E	E	4552	D
Exit 6A Off-Ramp	335	F	F	422	C/D
Exit 6A On-Ramp	382	E	E	407	D
Exit 6 (Weave Area)	4103	E	E	4537	D
Exit 6B Off-Ramp	604	E	E	604	D
Exit 6B On-Ramp	931	F	E	911	C/D
Exit 6 to Exit 7	4430	F	E	4484	C/D
Exit 7 Off-Ramp	652	F	E	776	C/D
Exit 7 On-Ramp	1521	F	F	1373	D
Exit 7 to Exit 8	5299	F	F	5441	D

Table 4.27: 2025 AM Peak SB LOS Impact - Exit 6 Area

Southbound				6-Lane(Aux) Exit 6 Area	
	2025 AM	2025 AM	2025 AM	2025 AM	2025 AM
	Volume	No-Buil	Aux. Lanes	Volume	
Exit 8 to Exit 7	4769	F	E	4922	C/D
Exit 7 Off-Ramp	1541	F	E	1393	C/D
Exit 7 On-Ramp	532	D/E	D/E	656	C/D
Exit 7 to Exit 6	3760	E	E	4185	C/D
Exit 6B Off-Ramp	401	E/D	E/D	426	D
Exit 6B On-Ramp	324	E	E	411	D
Exit 6 (Weave Area)	3683	E	E	4170	D
Exit 6A Off-Ramp	802	E	E	782	D
Exit 6A On-Ramp	416	D	D	416	C
Exit 6 to Exit 5	3297	D	D	3804	C
Exit 5B Off-Ramp	602	C	C	779	C/B
Exit 5B On-Ramp	311	C	C	311	B
Exit 5A On-Ramp	472	C	C	575	B

Table 4.28: 2025 PM Peak SB LOS Impact - Exit 6 Area

Southbound				6-Lane(Aux) Exit 6 Area	
	2025 PM	2025 PM	2025 PM	2025 PM	2025 PM
	Volume	No-Build	Aux. Lanes	Volume	
Exit 8 to Exit 7	3004	D	C	3226	B
Exit 7 Off-Ramp	571	D	C	562	B
Exit 7 On-Ramp	1170	D	D	1396	C/D
Exit 7 to Exit 6	3603	E/D	E/D	4060	C
Exit 6B Off-Ramp	246	D/E	D/E	314	E
Exit 6B On-Ramp	599	F	F	823	E
Exit 6 (Weave Area)	3956	F	F	4569	E
Exit 6A Off-Ramp	675	F	F	821	E
Exit 6A On-Ramp	606	E/D	E/D	701	C
Exit 6 to Exit 5	3887	E	E	4449	D
Exit 5B Off-Ramp	365	E	E	451	C
Exit 5B On-Ramp	409	D/C	D/C	135	B
Exit 5A On-Ramp	195	D/C	D/C	227	B

With the added lanes from Exit 5 to Exit 7, three additional capacity deficit locations in Table 3.3 would be eliminated. The locations would be Exit 5 to Exit 6 northbound PM, Exit 7 to Exit 8 northbound PM, and Exit 6 southbound PM. The two remaining, of the ten capacity constraint locations, would be Exit 5 to Exit 4 southbound PM and Exit 8 to Exit 9 northbound PM.

Forest Avenue

The two loop off-ramps at I-295 Exit 6 (northbound-to-westbound and southbound-to-eastbound) terminate on Forest Avenue at an acute (shallow) angle. Forest Avenue, at these points, maintains three travel lanes and a sidewalk on each side of the median island. The acute angle allows off-ramp traffic to merge with Forest Avenue traffic at excessive speed, but the high volumes on Forest Avenue, with an AADT over 35,000 vehicles per day, makes smooth entry from the off-ramps difficult. Vehicles slowing or stopping before entering Forest Avenue are vulnerable to being rear-ended by another vehicle on the off-ramp. As a result, both off-ramp termini are High Crash Locations with a high number of rear-end crashes. Each location has experienced 50 or more crashes in a 3-year period (see crash diagrams in Appendix 1). Although pedestrians and bicyclists have not been directly involved in these crashes, excessive off-ramp speeds also pose a risk to these users of Forest Avenue. In addition to the damages and injuries that result from crashes, traffic flow at Exit 6 can be severely disrupted as traffic on the off-ramp queues back to the I-295 mainline.

A lesser off-ramp issue is at the northbound Exit 6A off-ramp. Often, long queues develop as vehicles wait for opportunities to enter Forest Avenue. However, the queues typically do not interfere with I-295 northbound mainline traffic flow and the entry point to Forest Avenue is not a High Crash Location.

As shown in Figure 4.10, the proposed action would be to realign the ends of the two loop off-ramps to Forest Avenue and modify the curb lines on Forest Avenue to reduce ramp speeds at the ramp termini and to provide protection for vehicles entering from the off-ramps. Sidewalks would also be modified to shorten crosswalks which, along with the slower ramp speeds, would further improve pedestrian safety at the ramp termini.

Figure 4.10: Exit 6 Forest Ave. Improvement Concept (enlarged in Appendix 23)



Modifications at the loop off-ramp termini would improve traffic safety by reducing crash frequencies at the loop off-ramp termini. This, in turn, will result in less traffic congestion on I-295 due to traffic flow disruptions at the ramps. The signalization and added vehicle storage for the northbound Exit 6 A off-ramp would reduce the length of queues on the ramp.

As stated in Section A above, the addition of travel lanes on I-295, would improve the level of service on the mainline and at ramp junctions. The arterial level of service on Forest Avenue was evaluated for existing and future PM conditions.

For urban streets such as Forest Avenue, the HCM 2000 level of service is based on average travel speed for the street overall and on control delay per vehicle for signalized intersections. The LOS thresholds for urban streets and signalized intersections are summarized in Table 4.29 below.

Table 4.29: Urban Street and Signalized Intersection LOS

Level of Service	Urban Streets (Class III) Avg. Travel Speed (mph)	Signalized Intersections Control Delay (sec/veh)
A	>30	<10
B	24-30	0-20
C	18-24	20-35
D	14-18	35-55
E	10-14	55-80
F	<10	>80

Table 4.30 shows five scenarios for the overall level of service for Forest Ave between Falmouth Street/Preble Street Extension and Park Avenue. For existing conditions, the Forest Avenue LOS is E. For future baseline conditions, the LOS would be F. The existing Forest Avenue does not have the capacity to accommodate future baseline conditions. There would be long delays and queues with the intersections of Forest Avenue and High Street, Exit 6A/B NB off-ramp, and Exit 6A SB off-ramp.

The LOS on Forest Avenue could be improved from F to E/F with the following actions.

- Make improvements as described above and shown in Figure 4.10.
- Add a second lane to and signalize the Exit 6A northbound off-ramp (right turn only).
- Add a second right-turn movement from inbound Forest Avenue to the two-lane State Street at the Marginal Way intersection.
- Add a third lane on the High Street approach to Forest Avenue and outbound on Forest Avenue between High Street and Marginal Way.

With the above improvements, a 2025 baseline LOS E/F can be achieved on Forest Avenue. Adding travel lanes on I-295 would be expected to increase traffic volumes on Forest Avenue. When these increased traffic volumes are taken into account, along with the above actions on Forest Avenue, the LOS would be downgraded again to F. There would also be a resulting increase in congestion (to LOS E) at the Forest Avenue/Bedford Street intersection.

Table 4.30: 2025 PM Peak LOS Impact on Forest Avenue

Forest Avenue Park Ave. to Preble St.	I-295 at Exit 6	Arterial LOS	Average Speed
Existing Conditions	Existing Conditions	E	13 mph
2025 with no improvements	2025 with no improvements	F	7 mph
2025 with improvements	2025 with no improvements	E/F	10 mph
2025 with improvements	2025 with median lanes	F	8 mph
2025 with added improvements	2025 with median lanes	E	12 mph

As shown in Table 4.30, to improve the Forest Avenue LOS from F to E, additional improvements along Forest Avenue would be needed. These would consist of prohibiting left turns from outbound Forest Avenue to Bedford Street (as left turns are prohibited from inbound Forest Avenue onto Baxter Boulevard), and routing that left-turning traffic to Preble Street Extension instead. Taken together, the improvements above on Forest Avenue and the restrictions at Bedford Street would result in a LOS E on Forest Avenue.

Table 4.31 below shows the signalized level of service at the Bedford Street and the Falmouth Street intersections for two scenarios: a Forest Avenue with improvements and an I-295 with no improvements, and a Forest Avenue with added improvements and an I-295 with median lanes. Prohibiting left turns onto Bedford would improve the LOS from D to B while the LOS at Falmouth Street/Preble Street Extension would drop from C to D.

Table 4.31 2025 PM Peak LOS Impact - Forest Avenue Signalized Intersections

Intersection	2025 With Forest Ave. improvements	2005 Median Lanes on I-295 W/Added Improvements
Forest Ave @ Bedford Street	D (39 sec/veh)	B (19 sec/veh)
Forest Ave. @ Falmouth/Preble St. Ext.	C (26 sec/veh)	D (40 sec/veh)

Congestion challenges on Forest Avenue around Exit 6 can be addressed by intersection improvement actions described in the preceding paragraphs. It should also be noted that there is also a TDM approach to managing traffic congestion on Forest Avenue. Just as future congestion on I-295 can be mitigated with the help of TDM actions, future congestion on Forest Avenue can be mitigated with the help of actions that could reduce traffic growth on this urban arterial. Local policies and actions that encourage carpooling, use of local transit, or use of bicycle and pedestrian modes can reduce traffic growth on Forest Avenue.

3. Exit 11 and Exit 10 (Maine Turnpike Falmouth Spur)

The Exit 11 and Exit 10 in Falmouth are two closely spaced interchanges which serve different purposes. Exit 11, which carries approximately 5000 vehicles per day from and to the Falmouth Spur of the Maine Turnpike, currently is not a full-service interchange. Exit 10 is a full-service interchange on Bucknam Road, which links I-295 to Route 1 on the east. Falmouth Spur traffic oriented toward Portland must exit onto Route 1 and use Bucknam Road to gain access to I-295. These exits are characterized by inadequate acceleration and deceleration lanes, and by sharp curves that severely limit ramp speeds and contribute to truck rollovers. The 2002 AADT on I-295 in this area was approximately 23,000 vehicles per day in each direction.

The auxiliary lane strategy discussed and analyzed in Section IV.B.2. could be a first step in improving the Exit 10 and Exit 11 area. The Exit 11 northbound on-ramp has an inadequate acceleration lane and is inadequately spaced from the northbound Exit 10 on-ramp, located less than 700 feet upstream. On-ramp traffic is unable to safely reach mainline speed before merging with mainline traffic. The first of the ramp extensions would be the on-ramp from the Falmouth Spur to I-295 northbound. The extension of the northbound on-ramp of Exit 11 would increase the effective separation between the Exit 11 on-ramp and the northbound Exit 10 on-ramp.

The Falmouth Spur not only connects the Maine Turnpike to I-295 (toward Brunswick and the Maine's Mid-Coast region) but it also connects to Route 1. The ramps leading to and coming from the Falmouth Spur (from/to I-295) have very sharp curves, considering that they connect two Interstate routes. Providing a higher speed and a safer system of ramps for these two movements would improve the connection between the Maine Turnpike and I-295. Figure 4.11 shows improving the southbound off-ramp by eliminating the sharp curve and increasing the radius to a 50 mph operating speed (Figure 4.11 shows new ramps shaded in yellow and removed ramps shaded in red). Addressing the Falmouth Spur to I-295 northbound movement is more difficult. There is no room to increase the radius of the current loop off-ramp. Figure 4.11 shows a flyover that would go over the Falmouth Spur and I-295, then connect with I-295 northbound north of the Falmouth Spur. The existing northbound loop on-ramp would be abandoned. Like the extensions of the ramps, these two ramp relocations could be a stand-alone project.

Figure 4.11: Exit 10 and Exit 11 Improvement Concept (enlarged in Appendix 23)

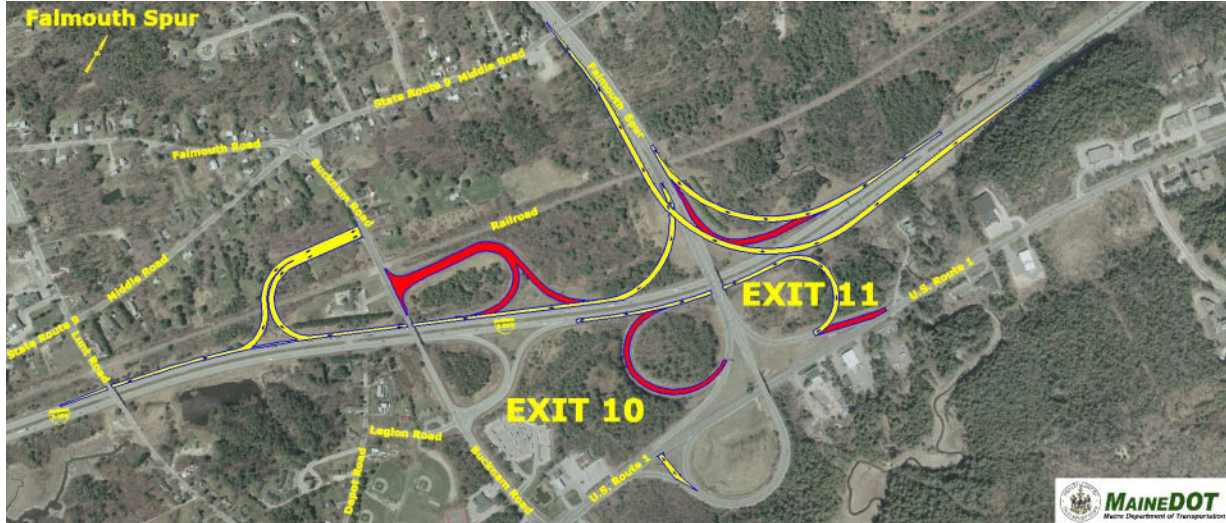

Exit 11 is not a full-service interchange. Vehicles on I-295 northbound are not able to directly go to Falmouth Spur westbound and vehicles eastbound on the Falmouth Spur are not able to go southbound on I-295. For these two movements vehicles currently must utilize Exit 10, Bucknam Road, and Route 1.

The I-295 northbound to Falmouth Spur movement would be added by constructing a new loop off-ramp north of the Falmouth Spur. The longer acceleration lane (discussed above as part of acceleration lane extension) would be used as the deceleration lane for this new off-ramp. The new off-ramp would connect to the existing on-ramp from Route 1 southbound to the Falmouth Spur. To avoid conflicts, the Route 1 southbound traffic would be relocated to the Route 1 northbound on-ramp. Relocating the northbound Exit 11 on-ramp would improve the northbound Exit 10 on-ramp by giving it a longer acceleration lane in the weaving section between the two interchanges.

The construction of a new ramp from the Falmouth Spur to I-295 southbound would impact Exit 10. The new on-ramp would be too close to the existing southbound off-ramp at Exit 10. Exit 10 ramps would have to be relocated south of Bucknam Road. This would result in a weave section southbound between Exit 11 and Exit 10. A side benefit of relocating the Exit 10 ramps would be the potential location for an intermodal facility that could accommodate carpooling and commuter transit, including passenger rail service.

As shown in Tables 4.32 and 4.33, the level of service would improve. During the PM peak, the northbound section LOS between Exit 10 and Exit 11 would improve from an E to C.

Table 4.32: 2025 AM Peak LOS Impact - Exit 10 and Exit 11

				Full Service Interchange	
	2025 AM Volume	2025 AM No-Build	2025 AM Aux Lanes	2025 AM Volume	2025 AM Type A
NB Exit 10 Off-Ramp	308	B	B	313	B
NB Exit 10 On-Ramp	297	B	B	256	A
NB Exit 10 to Exit 11	1695	C	C	1690	A
NB Exit 11 Off-Ramp	N/A	N/A	N/A	0	A
NB Exit 11 On-Ramp	518	C	B	523	B
SB Exit 11 Off-Ramp	734	E	D	767	D/E
SB Exit 11 On-Ramp	N/A	N/A	N/A	161	B
SB Exit 11 to Exit 10	2969	C	C	3100	B
SB Exit 11 Off-Ramp	414	D	C	416	B
SB Exit 11 On-Ramp	848	D	C	763	C

Table 4.33: 2025 PM Peak LOS Impact - Exit 10 and Exit 11

				Full Service Interchange	
	2025 PM Volume	2025 PM No-Build	2025 PM Aux Lanes	2025 PM Volume	2025 PM Aux Lanes
NB Exit 10 Off-Ramp	808	E/D	D	723	D
NB Exit 10 On-Ramp	454	D	D	456	C
NB Exit 10 to Exit 11	3219	E	E	3350	C
NB Exit 11 Off-Ramp	N/A	N/A	N/A	N/A	C
NB Exit 11 On-Ramp	664	E	D/C	697	D
SB Exit 11 Off-Ramp	1078	D	C	1083	C
SB Exit 11 On-Ramp	N/A	N/A	N/A	N/A	B/A
SB Exit 11 to Exit 10	1875	B	B	1871	B/A
SB Exit 11 Off-Ramp	367	B/C	B/C	326	B/A
SB Exit 11 On-Ramp	378	B	B	383	B

A full-service interchange at Exit 11 would provide some reduction in vehicular traffic using Bucknam Road and Route 1 to make the connection between the Falmouth Spur and points south on I-295. This traffic volume reduction would provide a modest safety and mobility benefit to local motorists, bicyclists, and pedestrians that use Bucknam Road and Route 1 in Falmouth.

4. Exit 15

Exit 15 is a busy I-295 interchange with Route 1 that has several deficiencies. The southbound on-ramp at Exit 15 near the Cumberland/Yarmouth town line adds an AADT of approximately 5000 vehicles per day to the 23,000 AADT on I-295 southbound. For the northbound, there are approximately 28,000 vehicles (prior to Exit 15) and approximately 5000 vehicles exit at Exit 15. The straight alignment of the southbound on-ramp and its tangent approach to the downstream mainline of I-295 invites high-speed entry onto I-295 with little consideration for upstream I-295 traffic, which enters the ramp junction area on a curve. The on-ramp lacks a parallel acceleration lane. The result of these deficiencies is a High Crash Location at the ramp junction. The location currently operates at a LOS D in the AM peak hour.

Another deficiency of Exit 15 is the lack of a northbound on-ramp, which would allow Exit 15 to be a full-service interchange with four interchange ramps. The lack of this on-ramp adds a traffic burden to Route 1 and Exit 17 (where a full interchange exists) in Yarmouth and reduces the value of Exit 15 as a park-and-ride location.

To address the High Crash Location, the proposed action would reconstruct the southbound on-ramp to provide a curved lower-speed alignment and a parallel acceleration lane approximately 1000 feet in length along I-295 (see Figure 4.12). The realigned southbound on-ramp would address the High Crash Location at the ramp junction with I-295 and improve the 2025 AM peak LOS from E to D. The realignment of the southbound on-ramp would create an opportunity for a park-and-ride lot along the St. Lawrence & Atlantic railroad line for potential commuter bus and rail service.

Figure 4.12: Exit 15 Improvement Concept (enlarged in Appendix 23)

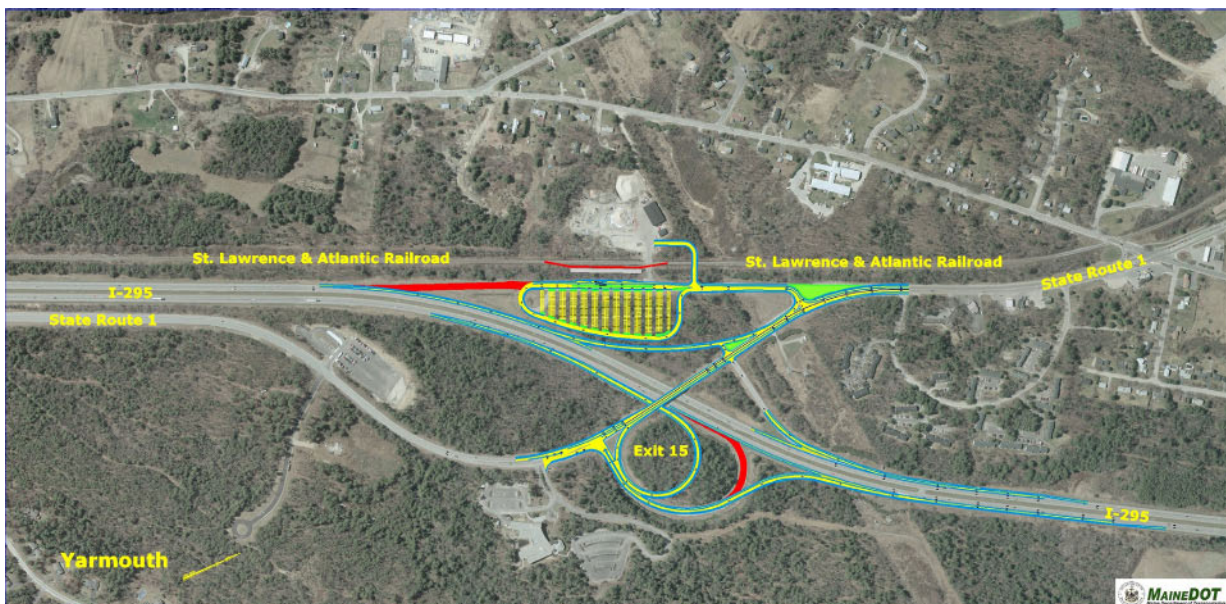

Three different options were analyzed for the location of the fourth ramp needed to make the interchange full-service. Option A, a modified diamond configuration, would add a northbound on-ramp in the same quadrant as the existing northbound off-ramp. Option B, a partial cloverleaf configuration, would add a northbound loop on-ramp between Route 1 and I-295. This would create a northbound weaving section on I-295 between the new on-ramp and the existing off-ramp. Option C, a diamond configuration, would construct a new northbound off-ramp in the southeasterly quadrant and convert the existing off-ramp to a northbound on-ramp.

For the different options, Table 4.34 below shows the vehicle-miles and vehicle-hours of interchange users during the PM peak hour. The time savings in vehicle-hours result from the new on-ramp attracting northbound traffic that would otherwise travel Route 1 through Yarmouth and entering I-295 at Exit 17.

Table 4.34: 2025 PM Peak Exit 15 Ramp Options

	Distance (Veh.-Mi.)	Time (Veh-Hr.)	Time Savings (Veh-Hr.)
No Build			0
Option A Modified Diamond	425	10.5	10.5
Option B Modified Diamond w/ Weaving	567	13.5	7.5
Option C Diamond	286	11.9	9.1

There are advantages and disadvantages to all three options. The major advantage of Option A is that provides the great amount of time savings for interchange users. A disadvantage of Option A is that the northbound loop off-ramp would need to be modified to minimize ledge cuts and right-of-way acquisition for the northbound on-ramp. Option B has the advantage of minimizing the number of left turns made on Route 1 by having two loop ramps. Option B’s major disadvantage is the creation of a short weaving segment on I-295 which would create operational concerns and require modifications to the Route 1 bridge. Option C has the advantage of having the greatest savings in vehicle-miles. The main disadvantage of Option C is that northbound exiting vehicles bound for Yarmouth area would need to turn left at a potential signal (or roundabout) instead of the right turn off the loop ramp as they do now.

Each of the Options would require maintaining the three lanes of vehicular traffic on the existing Route 1 bridge over I-295. With 40 feet of width between curbs on the bridge, the accommodation of bicycle or pedestrian facilities along this portion of Route 1 is already a challenge.

Figure 4.12 also shows lengthening the southbound deceleration lane as described in section IV B 1. Other improvements at Exit 15 could include turn lanes on Route 1 and a potential park-and-ride lot and commuter bus and rail service on the site of the existing southbound on-ramp.

G. New Highway Capacity

The new highway capacity strategy would involve the construction of new through travel lanes for extended lengths of the highway to increase the vehicular capacity of the highway corridor.

1. Maine Turnpike (I-95)

In its *Ten Year Planning Report*, The Maine Turnpike Authority has proposed new highway capacity on the Maine Turnpike (I-95) in Portland and South Portland. This action would add one through lane in each direction to the Maine Turnpike between Exit 44 and Exit 53 as shown in Figure 4.13.

Figure 4.13: Maine Turnpike Widening



While the primary purpose of the Maine Turnpike widening would be to improve traffic flow for users of the Maine Turnpike, the PACTS model has estimated that this action can divert over 350 through vehicles in the peak hour from I-295 to the Maine Turnpike. This shift in traffic volume would also serve a secondary purpose of improving traffic flow on I-295. As more through traffic would use I-95 and the Falmouth Spur, the improvement to existing I-295 Exit 11 ramps also would support this secondary purpose by making the use of the Falmouth Spur and I-95 more attractive to traffic that could be diverted from I-295. For the purpose of the I-295 analysis, the I-95 widening action would also include the supporting improvement of existing ramps between I-295 Exit 11 and the Falmouth Spur.

Appendix 12 and Appendix 13, respectively, include diagrams of the 2025 AM and PM peak design hour volumes and the level of service, comparing six-lanes on the Maine Turnpike between Exit 44 and Exit 53 (combined with the auxiliary lanes strategy on I-295) to the baseline (No-Build) for the Study Area. Table 4.35 is a summary of the levels of service for the Study Area during the 2025 AM Peak. In comparison with the AM peak with auxiliary lanes (Table 4.2), the MTA 6-lane action (Table 4.35) would reduce the number of LOS E's on I-295 from 15 to 8.

Table 4.35: 2025 Maine Turnpike 6-Lanes w/Aux. Lanes on I-295 LOS AM Peak

		2025 MTA 6-Ln Aux. Lanes LOS AM Peak					
		A	B	C	D	E	F
On/Off Ramps	Southbound	1	3	16	9	3	0
	Northbound	0	21	3	7	2	0
Segments Between On/Off Ramps	Southbound	2	2	6	8	2	0
	Northbound	1	13	2	4	1	0

Table 4.36 shows the baseline volumes and the new volumes (resulting from the increase in number of lanes on the Maine Turnpike) for the 15 locations where the auxiliary lane strategy would result in LOS E during the AM Peak. The locations where LOS would remain E are northbound at Exit 3, southbound at Exit 8 to Exit 7, and southbound in the weave area at Exit 6.

Table 4.36: 2025 AM Peak LOS Impact - MTA 6-Lanes

				MTA 6-Ln Aux	
	2025 AM Volume	2025 AM No-Build	2025 AM Aux. Lns.	2025 AM Volume	2025 AM
NB Exit 3 On-Ramp	755	F	E	741	E
NB Exit 3 to Exit 4	4560	F	E	4426	E
NB Exit 4 Off-Ramp	1555	F	E	1606	E
NB Exit 5 Off-Ramp	649	E/D	E/D	661	D
SB Exit 9 On-Ramp	825	E	E	807	D/E
SB Exit 9 (Weave Area)	4228	E	E	3997	D/E
SB Exit 9 Off-Ramp	349	E	E	344	D/E
SB Exit 9 to Exit 8	3879	E	E	3633	D/E
SB Exit 8 to Exit 7	4769	F	E	4524	E
SB Exit 7 Off-Ramp	1541	F	E	1527	E
SB Exit 7 to Exit 6	3760	E	E	3539	D
SB Exit 6B Off-Ramp	401	E/D	E/D	405	D
SB Exit 6B On-Ramp	324	E	E	334	E
SB Exit 6 (Weave Area)	3683	E	E	3468	E
SB Exit 6A Off-Ramp	802	E	E	791	E

Table 4.37 is a summary of the levels of service for the Study Area during the 2025 PM Peak. In comparison with the PM peak with the auxiliary lanes (Table 4.3), the MTA 6-lane action (Table 4.37) would reduce the number of LOS E's from 25 to 20 and would reduce the number of LOS F's from 9 to 2.

Table 4.37: 2025 Maine Turnpike 6-Lanes w/Aux. Lanes on I-295 LOS PM Peak

		2025 MTA 6-Ln Aux. Lanes LOS PM Peak					
		A	B	C	D	E	F
On/Off Ramps	Southbound	0	9	11	6	6	0
	Northbound	1	2	4	19	6	1
Segments Between On/Off Ramps	Southbound	0	6	8	2	4	0
	Northbound	1	1	3	11	4	1

Table 4.38 shows the baseline volumes and the new volumes (resulting from the increase in number of lanes on the Maine Turnpike) for the 34 locations where the auxiliary lanes strategy would have LOS E or F during the PM Peak. For approximately two-thirds of the 34 locations, the LOS would remain E or F, even with the 6 lanes on the Turnpike. Eleven locations improve to LOS D or C. For northbound Exit 6A off-ramp, northbound between Exit 8 and 9, southbound Exit 6 weave area, southbound Exit 5A on-ramp and southbound Exit 4 off-ramp, LOS would be improved from F to E. LOS would remain LOS F at northbound Exit 7 on-ramp and between northbound Exit 7 and 8.

Table 4.38: 2025 PM Peak LOS Impact - MTA 6-Lanes

				MTA 6-Ln Aux	
	2025 PM	2025 PM	2025 PM	2025 PM	2025 PM
	Volume	No-Build	Aux. Lns.	Volume	
NB Exit 3 to Exit 4	3643	E	E	3414	E
NB Exit 5 Off-Ramp	631	E/D	E/D	595	D
NB Exit 5 On-Ramp	302	E	E	303	E/D
NB Exit 5 to Exit 6	4056	E	E	3861	E
NB Exit 6A Off-Ramp	335	F	F	345	E/D
NB Exit 6A On-Ramp	382	E	E	386	E
NB Exit 6 (Weave Area)	4103	E	E	3902	E
NB Exit 6B Off-Ramp	604	E	E	622	E
NB Exit 6B On-Ramp	931	F	E	920	D
NB Exit 6 to Exit 7	4430	F	E	4200	D
NB Exit 7 Off-Ramp	652	F	E	662	D
NB Exit 7 On-Ramp	1521	F	F	1507	F
NB Exit 7 to Exit 8	5299	F	F	5045	F
NB Exit 8 On-Ramp	1012	E	E	997	E
NB Exit 8 (Weave Area)	6311	E	E	6042	E
NB Exit 8 Off-Ramp	2062	E	E	2048	E
NB Exit 8 to Exit 9	4249	F	F	3994	E
NB Exit 9 On-Ramp	359	E	E	354	D/E
NB Exit 9 (Weave Area)	4608	E	E	4348	D/E
NB Exit 9 Off-Ramp	1035	E	E	1017	D/E
NB Exit 10 to Exit 11	3219	E	E	3019	C
NB Exit 11 to Exit 15	3883	E	E	3718	D
SB Exit 7 to Exit 6	3603	E/D	E/D	3387	D
SB Exit 6B On-Ramp	599	F	F	594	E
SB Exit 6 (Weave Area)	3956	F	F	3734	E
SB Exit 6A Off-Ramp	675	F	F	661	E
SB Exit 6A On-Ramp	606	E/D	E/D	619	D
SB Exit 6 to Exit 5	3887	E	E	3692	E/D
SB Exit 5A On-Ramp	494	F	F	483	E/D
SB Exit 5 to Exit 4	4230	E/F	E/F	4033	E
SB Exit 4 Off-Ramp	785	F	F	773	E
SB Exit 4 On-Ramp	1535	F	E	1586	E
SB Exit 4 to Exit 3	4980	F	E	4846	E
SB Exit 3 Off-Ramp	1265	F	E	1251	E

2. I-295 Exit 2 to Exit 9

This action would add one through lane in each direction on I-295 between Exit 2 and Exit 9 as shown in Figure 4.14. The Exit 2 to Exit 9 action was analyzed to address the poor levels of service in the Portland and South Portland area and to address the remaining capacity constraints (Table 4.4) that were not addressed with auxiliary lanes.

Figure 4.14: I-295 Exit 2 to Exit 9



The added lanes would be constructed in the existing median, starting north of Exit 2 on-ramp and continuing to Exit 8. From Exit 8 on-ramp to Exit 8 off-ramp (Tukey's Bridge) the existing number of lanes would be maintained. On the north side of Tukey's Bridge, one of the future capacity constraints is the northbound two-lane section between the Exit 8 (Washington Avenue) off-ramp and the Exit 9 (Baxter Boulevard) on-ramp. A way to address the constraint would be to convert the two lanes into three lanes and also provide an auxiliary lane at Exit 9 between the Baxter Boulevard on-ramp and the off-ramp to Route 1 to Falmouth. The construction of an auxiliary lane would have to occur on the outside, not in the median. It may be possible to add a third lane on the bridge (over the Washington Avenue off-ramp) within the existing space if the resulting narrow shoulders would be acceptable to FHWA. The shoulders might be two feet on the left side and up to six feet on the right side. If this were not acceptable, then more expensive means of obtaining the needed roadway width would need to be considered.

There also would be bridge construction issues over the Fore River in South Portland. Most of the I-295 bridges over land in Portland and South Portland have a single span (no intermediate bridge piers) in each direction and a single set of bridge abutments shared by northbound and southbound bridge decks. This allows additional deck area in the median for travel lanes to be constructed without additional construction underneath. The Fore River bridge, however, has five spans and four piers in each direction that are not shared. Additional deck area in the median would also require additional pier construction in the Fore River, adding to the cost of the Exit 2 to Exit 9 action.

The PACTS model has shown that increasing the number of through lanes on I-295 would affect the traffic patterns in Portland. The added lanes could attract the diversion of over 250 through vehicles in the peak hour from the Maine Turnpike to I-295. With the added lanes, traffic would increase on I-295 and Forest Avenue between Park Avenue and Baxter Boulevard. However, traffic would decrease on the Veteran's Bridge, Park Avenue, outer Congress Street and other parts of the Peninsula.

Appendix 14 and Appendix 15, respectively, include diagrams of the 2025 AM and PM peak design hour volumes and the level of service, comparing six-lanes on I-295 Exit 2 and Exit 9 (combined with the Auxiliary Lanes Strategy on I-295) to Baseline (No-Build) for the Study Area. Table 4.39 is a summary of the levels of service for the Study Area during the 2025 AM peak. In comparison with the AM peak with auxiliary lane (Table 4.2), the I-295 Exit 2 to Exit 9 6-lane strategy (Table 4.39) would reduce the number of LOS E's from 15 to 8 and the number of LOS F's from 9 to 0.

Table 4.39: 2025 Exit 2 to Exit 9 6-Lanes w/Aux. Lanes on I-295 LOS AM Peak

		2025 Exit 2 to Exit 9 6-Ln Aux. Lanes LOS AM Peak					
		A	B	C	D	E	F
On/Off Ramps	Southbound	3	3	15	6	5	0
	Northbound	0	20	12	1	0	0
Segments Between On/Off Ramps	Southbound	2	3	6	6	3	0
	Northbound	1	11	9	0	0	0

Table 4.40 shows the baseline volumes and the new volumes (resulting from the increase in number of lanes on I-295 between Exit 2 and Exit 9) for the 15 locations where the auxiliary lane strategy would result in LOS E during the AM peak. The locations where LOS would remain at E are southbound at Exit 9, southbound at Exit 9 to Exit 8, and southbound at Exit 6B off-ramp. Because of the increase in vehicles, the level of service would worsen on Tukey’s Bridge (not shown in Table 4.40; see Appendix 14). LOS would go from D to E/D. Overall, the AM peak LOS would improve in the Portland and South Portland areas except southbound in the Tukey’s Bridge area.

Table 4.40: 2025 AM Peak LOS Impact - Exit 2 to Exit 9 6-Lanes

				Exit 2 to 9 6-Ln Aux	
	2025 AM	2025 AM	2025 AM	2025 AM	2025 AM
	Volume	No-Build	Aux. Lns.	Volume	
NB Exit 3 On-Ramp	755	F	E	737	C/D
NB Exit 3 to Exit 4	4560	F	E	4993	C/D
NB Exit 4 Off-Ramp	1555	F	E	1349	C/D
NB Exit 5 Off-Ramp	649	E/D	E/D	730	D
SB Exit 9 On-Ramp	825	E	E	880	E
SB Exit 9 (Weave Area)	4228	E	E	4461	E
SB Exit 9 Off-Ramp	349	E	E	288	E
SB Exit 9 to Exit 8	3879	E	E	4173	E
SB Exit 8 to Exit 7	4769	F	E	4932	C/D
SB Exit 7 Off-Ramp	1541	F	E	1315	C/D
SB Exit 7 to Exit 6	3760	E	E	4318	D/C
SB Exit 6B Off-Ramp	401	E/D	E/D	421	E/D
SB Exit 6B On-Ramp	324	E	E	454	D
SB Exit 6 (Weave Area)	3683	E	E	4351	D
SB Exit 6A Off-Ramp	802	E	E	783	D

Table 4.41 is a summary of the levels of service for the Study Area during the 2025 PM Peak. As compared to PM Peak with Auxiliary Lane (Table 4.3), the Exit 2 to Exit 9 6-lane strategy (Table 4.41) reduces the number of LOS E's from 25 to 8 and reduces the number of LOS F's from 9 to 1.

Table 4.41: 2025 Exit 2 to Exit 9 6-Lanes w/Aux. Lanes on I-295 LOS PM Peak

		2025 Exit 2 to 9 6-Ln Aux. Lanes LOS PM Peak					
		A	B	C	D	E	F
On/Off Ramps	Southbound	0	7	17	5	2	1
	Northbound	1	2	9	19	2	0
Segments Between On/Off Ramps	Southbound	0	5	11	3	1	0
	Northbound	1	2	4	11	3	0

Table 4.42 shows the baseline volumes and the new volumes (resulting from the increase in number of lanes on I-295) for the 34 locations where the auxiliary lane strategy would result in LOS E or F during the PM peak. For northbound Exit 6A off-ramp, northbound between Exit 7 and 8, northbound between Exit 8 and 9, southbound Exit 6 weave area, southbound Exit 5A on-ramp and southbound Exit 4 off-ramp, LOS F would be improved to LOS D, and the southbound Exit 6 weave area would be improved to LOS E. Locations where LOS would not improve are southbound Exit 6B off-ramp (from D/E to F) and northbound on Tukey's Bridge (from E to E/F).

Despite the increase of traffic on I-295, the 6-lanes Exit 2 to Exit 9 on I-295 action would offer significantly more improvements in I-295 level of service than the 6-lane Exit 44 to Exit 53 action on the Maine Turnpike. This is due to the direct nature of Exit 2 to Exit 9 action that would address the deficiencies by on-site changes. However, it should be noted that capacity and level of service issues on Tukey's Bridge itself would not be addressed and that conditions would be worsened at that location should volumes increase. To offset the impact at Tukey's Bridge, other actions (for example: commuter transit, differential tolls, or Maine Turnpike widening) that remove some of the traffic from I-295 may need to be taken.

Table 4.42: 2025 PM Peak LOS Impact - Exit 2 to Exit 9 6-Lanes

				Exit 2 to 9 6-Ln Aux	
	2025 PM	2025 PM	2025 PM	2025 PM	2025 PM
	Volume	No-Build	Aux. Lns.	Volume	
NB Exit 4 to Exit 5	3643	E	E	4320	C
NB Exit 5 Off-Ramp	631	E/D	E/D	660	D
NB Exit 5 On-Ramp	302	E	E	386	D/C
NB Exit 5 to Exit 6	4056	E	E	4859	D
NB Exit 6A Off-Ramp	335	F	F	465	D
NB Exit 6A On-Ramp	382	E	E	402	D
NB Exit 6 (Weave Area)	4103	E	E	4796	D
NB Exit 6B Off-Ramp	604	E	E	730	D
NB Exit 6B On-Ramp	931	F	E	912	D/C
NB Exit 6 to Exit 7	4430	F	E	4987	D/C
NB Exit 7 Off-Ramp	652	F	E	821	D/C
NB Exit 7 On-Ramp	1521	F	F	1295	D
NB Exit 7 to Exit 8	5299	F	F	5452	D
NB Exit 8 On-Ramp	1012	E	E	1145	E/F
NB Exit 8 (Weave Area)	6311	E	E	6597	E/F
NB Exit 8 Off-Ramp	2062	E	E	2064	E/F
NB Exit 8 to Exit 9	4249	F	F	4533	D
NB Exit 9 On-Ramp	359	E	E	298	C/D
NB Exit 9 (Weave Area)	4608	E	E	4831	C/D
NB Exit 9 Off-Ramp	1035	E	E	1090	C/D
NB Exit 10 to Exit 11	3219	E	E	3741	D
NB Exit 11 to Exit 15	3883	E	E	873	E/D
SB Exit 7 to Exit 6	3603	E/D	E/D	4172	C/D
SB Exit 6B On-Ramp	599	F	F	843	E
SB Exit 6 (Weave Area)	3956	F	F	4695	E
SB Exit 6A Off-Ramp	675	F	F	810	E
SB Exit 6A On-Ramp	606	E/D	E/D	771	C/D
SB Exit 6 to Exit 5	3887	E	E	4656	D
SB Exit 5A On-Ramp	494	F	F	616	D/C
SB Exit 5 to Exit 4	4230	E/F	E/F	5009	D
SB Exit 4 Off-Ramp	785	F	F	925	D
SB Exit 4 On-Ramp	1535	F	E	1329	D/C
SB Exit 4 to Exit 3	4980	F	E	5413	D/C
SB Exit 3 Off-Ramp	1265	F	E	1247	D/C

3. I-295 Exit 9 to Exit 28

This action would add one through lane in each direction on I-295 between Exit 9 and Exit 28 as shown in Figure 4.15. The action in this predominantly rural portion of the Study Area would be aimed at improving the poor levels of service projected for future conditions. In some areas, the additional pavement width could be obtained entirely within the median, but in other areas, some outside widening within the existing right-of-way would be needed.

Figure 4.15: I-295 Widening From Exit 9 to Exit 28

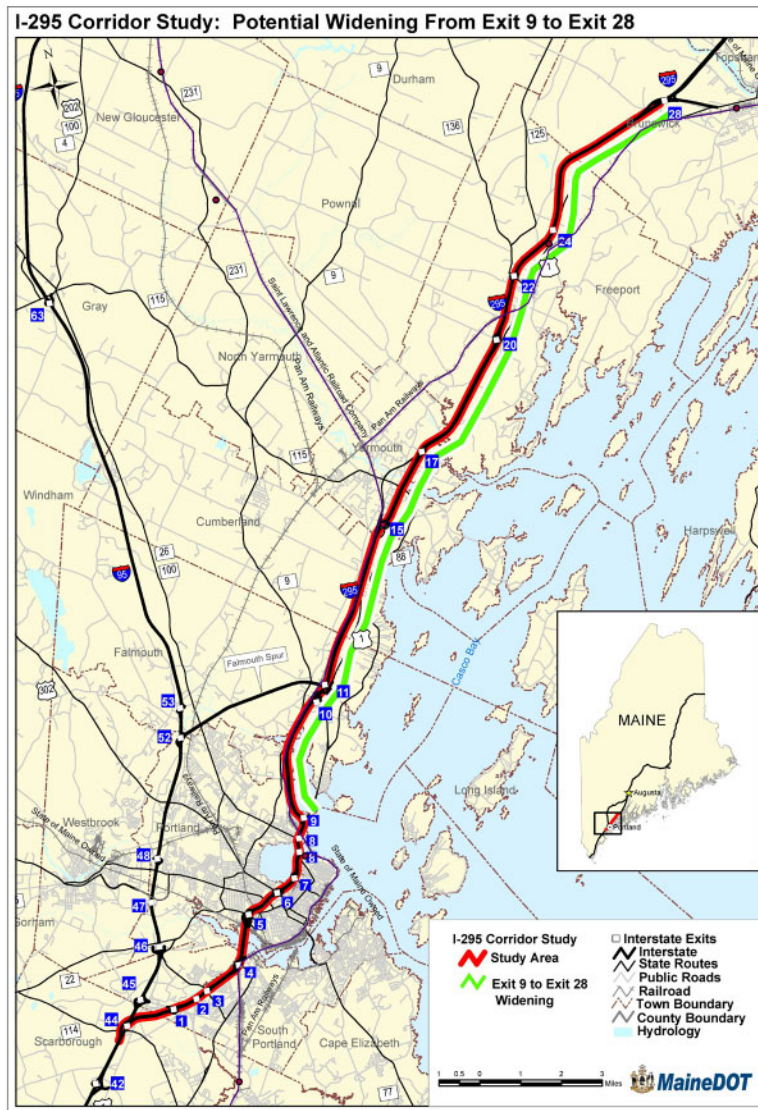

Appendix 16 and Appendix 17, respectively, include diagrams of the 2025 AM and PM peak design hour volumes and the level of service, comparing six-lanes on I-295 between Exit 9 and Exit 28 (combined with the auxiliary lanes strategy on I-295) to the baseline (No-Build) for the Study Area. Table 4.43 is a summary of the levels of service for the Study Area during the 2025 AM peak. Table 4.44 is a summary of the levels of service for the Study Area during the

2025 PM peak. With the auxiliary lane strategy alone, many of the rural locations would operate at LOS D, and two at LOS E. The six lanes between Exit 9 and Exit 28 strategy, in combination with auxiliary lanes, would result in LOS C or better for all the rural locations. For the non-peak direction, the rural LOS would be A or B.

Table 4.43: 2025 Exit 9 to Exit 28 6-Lanes w/Aux. Lanes on I-295 LOS AM Peak

		2025 Exit 9 to Exit 28 6-Ln Aux. Lanes LOS AM Peak					
		A	B	C	D	E	F
On/Off Ramps	Southbound	2	11	8	5	6	0
	Northbound	5	14	3	8	3	0
Segments Between On/Off Ramps	Southbound	2	7	4	2	5	0
	Northbound	8	4	3	5	1	0

Table 4.44: 2025 Exit 9 to Exit 28 6-Lanes w/Aux. Lanes on I-295 LOS PM Peak

		2025 Exit 9 to 28 6-Ln Aux. Lanes LOS PM Peak					
		A	B	C	D	E	F
On/Off Ramps	Southbound	1	16	3	5	3	4
	Northbound	1	7	8	5	10	2
Segments Between On/Off Ramps	Southbound	2	9	3	1	4	1
	Northbound	1	3	8	1	6	2

H. Effectiveness, Cost, and Challenges

The effectiveness of the actions at improving traffic operations can be compared by the use of several transportation performance measures. Mobility improvement can be measured in improved level of service and reduced delay in vehicle-hours traveled (VHT). Other useful performance measures for comparison of actions include vehicle-miles traveled (VMT) and Portland Peninsula parking demand. Measurements of VHT and VMT changes are based on the overall impact to the Greater Portland area. The effectiveness measurements are presented in Table 4.45. Effectiveness measurements in green represent beneficial effects. Measurements in red represent negative effects.

Putting changes in performance in perspective, a change of 1 million (1 M) VMT is equal to 0.03% of the Cumberland County VMT and 0.2% of the VMT in the City of Portland. A change of 1 million VHT is equal to 1.2% of the Cumberland County VHT and 6.0% of the Portland VHT.

The costs of the actions can be classified as capital costs and annual operating costs. Capital costs represent the initial costs of implementation such as right-of-way, construction, and transit vehicles. Operating costs include maintenance costs and the costs of operating services. The estimated capital and operating costs of actions are shown in Table 4.46.

Each action, if implemented, will have environmental, institutional, or technical challenges. Some issues may have a major impact on the feasibility of the action. Table 4.47 shows the major implementation challenges identified for I-295 Corridor actions.

Table 4.45: Effectiveness of Actions in 2025

Strategies	Actions	Measurements of Effectiveness			
		Peak Hour Volume Change	VHT Change (for year)	VMT Change (for year)	Other
Auxiliary Lanes	Weaving section improvements between Exits 3 and 4 in South Portland		Reduction		Improved capacity and level of service
	Weaving section improvements on I-295 approaches to Exit 7 in Portland		Reduction		Improved capacity and level of service
	Acceleration and deceleration lane improvements at various locations from Falmouth to Freeport		Reduction		Improved level of service
Intelligent Transportation Systems (ITS)	Variable message signing in Portland and South Portland		Reduction		Shorter and fewer incidents
	Traffic surveillance		Reduction		Shorter and fewer incidents
	Service patrols		-270000		Shorter and fewer incidents
Transportation demand Management (TDM)	High-occupancy vehicle lanes		Increase or no effect		
	Carpool incentives	-200	Reduction	Reduction	-200 in Portland parking demand
	Differential tolls	-250	-540000	+1.2 M	
Commuter Transit	Commuter bus service to Portland from north and south	-250 (inbound)	-820000	-8.5 M	-250 in Portland parking demand
	Commuter rail service to Portland from north and south	-400 (inbound)	-1.4 M	-27.0 M	-400 in Portland parking demand
Interchange Improvements	added ramps at Exit 4		-50000	+230000	Improved access
	added ramps at Exit 11		-110000	+200000	Improved access
	added ramp at Exit 15		reduction		Improved access and improved safety at HCL
	Median lanes at Exit 6	+100	-520000	+380000	Improved safety at HCL
New Highway Capacity	Added thru lanes on I-95 in Portland and South Portland (MTA)	-350	-1.7 M	+470000	Improved capacity for lane closures
	Added thru lanes on I-295 in Portland and South Portland	+250	-1.9 M	+850000	Improved capacity for lane closures
	Added thru lanes on I-295 from Falmouth to Brunswick		-1.4 M		Improved capacity for lane closures

Table 4.46: Costs of Actions

Strategies	Actions	Costs (2006 dollars)	
		Capital Cost	Operating Cost (for year)
Auxiliary Lanes	Weaving section improvements between Exits 3 and 4 in South Portland	\$7 million	\$20000
	Weaving section improvements on I-295 approaches to Exit 7 in Portland	\$2 million	\$20000
	Acceleration and deceleration lane improvements at various locations from Falmouth to Freeport	\$10 million	unknown
Intelligent Transportation Systems (ITS)	Variable message signing in Portland and South Portland	\$1 million	unknown
	Traffic surveillance	unknown	unknown
	Service patrols	unknown	\$200000
Transportation Demand Management (TDM)	High-occupancy vehicle lanes	unknown	Increase or no effect
	Carpool incentives	-	unknown
	Differential tolls	unknown	unknown
Commuter Transit	Commuter bus service to Portland from north and south	unknown	unknown
	Commuter rail service to Portland from north and south	\$40-90 million	\$3.5 million
Interchange Improvements	Added ramps at Exit 4	\$6 million	\$10000
	Added ramps at Exit 11	\$35 million	\$20000
	Added ramp at Exit 15	\$5 million	\$10000
	Median lanes at Exit 6	\$20 million	\$40000
New Highway Capacity	Added thru lanes on I-95 in Portland and South Portland (MTA)	\$75 million	\$180000
	Added thru lanes on I-295 in Portland and South Portland	\$50 million	\$120000
	Added thru lanes on I-295 from Falmouth to Brunswick	\$100 million	\$420000

Table 4.47: Major Implementation Challenges

Strategies	Actions	Potential Implementation Issues		
		Environmental	Institutional	Technical
Auxiliary Lanes	Weaving section improvements between Exits 3 and 4 in South Portland	Neighborhood noise concerns		
	Weaving section improvements on I-295 approaches to Exit 7 in Portland			
	Acceleration and deceleration lane improvements at various locations from Falmouth to Freeport			
Intelligent Transportation systems (ITS)	Variable message signing in Portland and South Portland		Coordination of agencies	
	Traffic surveillance		Coordination of agencies	
	Service patrols		Coordination of agencies	
Transportation Demand Management (TDM)	High-occupancy vehicle lanes			Insufficient right-of-way; Close spacing of interchanges
	Carpool incentives			
	Differential tolls		Coordination with MTA, potential need for legislation	Toll collection technology
Commuter Transit	Commuter bus service to Portland from north and south		Operating funds	
	Commuter rail service to Portland from north and south	Possible new bridge	Coordination with railroads, operating funds	
Interchange Improvements	Added ramps at Exit 4			
	Added ramps at Exit 11		Right-of-way needs	
	Added ramp at Exit 15			
	Reconfigured Exit 6			
New Highway Capacity	Added thru lanes in I-95 in Portland and South Portland (MTA)	Neighborhood noise concerns		
	Added thru lanes on I-295 in Portland and South Portland	Neighborhood noise concerns		Close spacing of interchanges
	Added thru lanes on I-295 from Falmouth to Brunswick	Possible wetland issues	May require some right-of-way acquisition	

I. Coordinated Strategies

A coordinated strategy is a combination of individual strategies that complement each other toward a common objective. Examples of coordinated strategies include low-cost improvements, improved interchange access to I-295, reduction in travel demand on I-295, and increased capacity on I-295. Table 4.48 shows how the individual actions can be combined into coordinated strategies.

The actions within a coordinated strategy can reduce the need for or the effectiveness of actions that follow a different coordinated strategy. For example, an action that shifts commuters to transit can reduce the need for additional highway capacity. On the other hand, an action that increases highway capacity can reduce the incentive for commuters to shift from their automobiles to transit. Among the I-295 coordinated strategies, the strategies to reduce I-295 volumes and increase I-295 capacity have the least compatibility.

The effectiveness of different coordinated strategies can be weighed by comparing the levels of service provided by the combined effects of the actions within each strategy. Tables 4.49 and 4.50 show the AM and PM levels of service for 2002 and 2025 baseline conditions and for the auxiliary lanes (TSM) strategy. For simplification purposes, the tables show only levels of service on the I-295 segments between interchanges, and not the levels of service for ramp junctions and weaving sections at the interchanges. The tables show the baseline growth of LOS E and F on several segments along I-295. As a major component of the low-cost TSM strategy, auxiliary lane improvements focus mostly on improving acceleration and deceleration capabilities at ramp junctions and weaving sections, and improve the level of service on some segments near Exits 3, 4, and 7. This strategy is compatible with all other strategies, as is the I-295 access improvement strategy, which can give motorists more travel route options and provide improved opportunities for park-and-ride transit services.

Tables 4.51 and 4.52 show the AM and PM levels of service for 2025 conditions for the volume reduction strategy and for two capacity increasing strategies (one that is urban and one that is both urban and rural). For each of these strategies, it is assumed that auxiliary lane improvements have been made in the I-295 Corridor. All three strategies show a major reduction in the number of I-295 segments operating at LOS E or F. The volume reduction strategy can improve all segments to LOS D or better. The increased capacity strategies can also provide LOS D or better on all but two segments. On one segment, between Exits 8 and 9, north of Tukey's Bridge, the narrow median and constrained location make the addition of capacity very difficult. On the other segment, between Exits 11 and 15, LOS E results unless additional capacity is provided at this rural location.

Both the volume reduction strategy and the increased capacity strategy can be effective strategies for the long term, and both are compatible with auxiliary lane improvements, ITS improvements, and improved interchange access.

Table 4.48: Coordinated Strategies

Coordinated Strategies	Characteristics	Actions
Transportation systems Management (TSM)	<ul style="list-style-type: none"> • To improve the operation of the existing facilities • Relatively low cost • Relatively minor environmental issues • Compatible with all other coordinated strategies 	<ul style="list-style-type: none"> • Weaving section improvements in South Portland and Portland • Acceleration and deceleration lane improvements at various locations from Falmouth to Freeport • Interstate highway management system (a combination of ITS actions including traffic monitoring, variable message signing, service patrols, and control center management)
I-295 Access Improvements	<ul style="list-style-type: none"> • To make physical improvements that enable more travelers to use I-295 interchanges • Mostly moderate in cost 	<ul style="list-style-type: none"> • Added ramps at Exits 4, 11, and 15 • Exit 16 improvements
I-295 Traffic Volume Reduction	<ul style="list-style-type: none"> • To redirect traffic to appropriate alternate routes • To encourage travelers to use multi-occupant vehicles • Low to high in cost • Minor to major environmental issues 	<ul style="list-style-type: none"> • Differential tolls and I-95 capacity increases to redirect through traffic to use the Maine Turnpike • Commuter transit service to Portland from north and south • Carpool incentives
I-295 Highway Capacity Increases	<ul style="list-style-type: none"> • To add vehicular capacity through construction of new through lanes on I-295 • Relatively high in cost • Relatively major environmental issues 	<ul style="list-style-type: none"> • Added thru lanes on I-295 in Portland and South Portland • Added thru lanes on I-295 from Falmouth to Brunswick

Table 4.49: I-295 AM Peak Mainline Segment LOS for Baselines and Aux. Lanes

AM 2002 Baseline		AM 2025 Baseline		AM 2025 Auxiliary Lanes					
Interchange	SB	NB	Interchange	SB	NB	Interchange	SB	NB	Interchange
28		B	28		B	28		B	28
24	B	B	24	C	B	24	C	B	24
22	C	B	22	D	B	22	D	B	22
20	C	B	20	C	B	20	C	B	20
17	C	B	17	C	B	17	C	B	17
15	D	B	15	D	B	15	D	B	15
11	C	B	11	C	C	11	C	C	11
10	C	B	10	D	B	10	D	B	10
9	D	B	9	E	C	9	E	C	9
8	E	B	8	F	C	8	E	C	8
7	D	C	7	E	E	7	E	D	7
6	D	C	6	D	D	6	D	D	6
5	C	C	5	C	D	5	C	D	5
4	C	D	4	D	F	4	C	E	4
3	B	D	3	C	D	3	C	D	3
2			2			2			2

LEVELS OF SERVICE



Table 4.50: I-295 PM Peak Mainline Segment LOS for Baselines and Aux. Lanes

PM 2002 Baseline		PM 2025 Baseline		PM 2025 Auxiliary Lanes					
Interchange	SB	NB	Interchange	SB	NB	Interchange	SB	NB	Interchange
28		B	28		D	28		D	28
24	B	C	24	C	D	24	C	D	24
22	B	C	22	C	D	22	C	D	22
20	C	C	20	C	D	20	C	D	20
17	B	C	17	C	D	17	C	D	17
15	C	D	15	C	E	15	C	E	15
11	B	D	11	B	E	11	B	E	11
10	B	C	10	B	D	10	B	D	10
9	C	E	9	C	F	9	C	F	9
8	C	D	8	D	F	8	C	F	8
7	D	E	7	E	F	7	E	E	7
6	D	D	6	E	E	6	E	E	6
5	D	D	5	E	E	5	E	E	5
4	E	D	4	F	E	4	E	D	4
3	C	C	3	D	C	3	D	C	3
2			2			2			2

LEVELS OF SERVICE

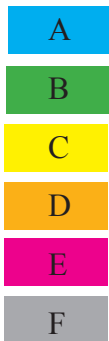





Table 4.51: I-295 AM Peak Mainline Segment LOS for Coordinated Strategies

AM 2025 Reduce Volume			AM 2025 Increase Capacity (U)			AM 2025 Increase Capacity (U+R)		
Interchange	SB	NB	Interchange	SB	NB	Interchange	SB	NB
28		B	28		B	28		A
24	C	B	24	C	B	24	B	A
22	D	B	22	D	B	22	B	A
20	C	B	20	C	B	20	B	A
17	C	B	17	C	B	17	B	A
15	C	B	15	D	B	15	B	A
11	C	A	11	C	B	11	B	A
10	C	A	10	D	B	10	B	A
9	D	B	9	E	B	9	E	B
8	D	C	8	D	C	8	D	C
7	D	C	7	C	C	7	C	C
6	C	C	6	C	C	6	C	C
5	C	D	5	C	C	5	C	C
4	C	D	4	B	C	4	B	C
3	C	D	3	B	C	3	B	C
2			2			2		

-  **REDUCE VOLUME**
Including auxiliary lanes, ITS, differential toll, added Turnpike capacity, commuter rail
-  **INCREASE CAPACITY**
Includes auxiliary lanes, ITS, added I-295 capacity South Portland, Portland
-  **INCREASE CAPACITY (U+R)**
Includes auxiliary lanes, ITS, added I-295 capacity South Portland to Brunswick

LEVELS OF SERVICE

-  A
-  B
-  C
-  D
-  E
-  F

Table 4.52: I-295 PM Peak Mainline Segment LOS for Coordinated Strategies

PM 2025 Reduce Volume			PM 2025 Increase Capacity (U)			PM 2025 Increase Capacity (U+R)		
Interchange	SB	NB	Interchange	SB	NB	Interchange	SB	NB
28			28			28		
24		D	24		D	24	B	B
22	C	D	22	C	D	22	B	B
20	C	D	20	C	D	20	B	B
17	C	D	17	C	D	17	B	B
15	C	C	15	C	D	15	B	B
11	C	D	11	C	E	11	B	B
10	A	C	10	B	D	10	A	B
9	A	C	9	B	D	9	A	B
8	B	D	8	C	D	8	C	D
7	C	C	7	B	D	7	B	D
6	D	C	6	C	D	6	C	D
5	D	D	5	D	D	5	D	D
4	D	D	4	D	C	4	D	C
3	C	C	3	D	C	3	D	C
2	D	C	2	C	B	2	C	B

- REDUCE VOLUME**
Includes auxiliary lanes, ITS, differential toll, added Turnpike capacity, commuter rail
- INCREASE CAPACITY**
Includes auxiliary lanes, ITS, added I-295 capacity South Portland, Portland
- INCREASE CAPACITY (U+R)**
Includes auxiliary lanes, ITS, added I-295 capacity South Portland to Brunswick

LEVELS OF SERVICE

- A
- B
- C
- D
- E
- F

V. Recommendations

The recommendations of the I-295 Corridor Study are a combination of several complementary strategies aimed to achieve the study purpose of providing safe and efficient transportation service through the year 2025. The near-term recommendations are a blend of specific projects to address the most immediate challenges. These near-term recommendations focus on getting the best operation possible out of the existing highway and making relatively low-cost improvements at specific locations most in need of attention. The long-term recommendations are a blend of improvements to existing infrastructure and new transportation service initiatives to address the needs of 2025. Included in the long-term recommendations are interchange improvements, actions that would divert portions of the I-295 traffic to other routes or transportation modes, and increases in highway capacity at targeted locations. The near-term and long-term recommendations are summarized in Figure 5.1.

A. The Need for Flexibility

External factors such as the aging population, new technology, energy costs, and the availability of transportation funding weigh heavily on the future of Maine's transportation system. These factors, along with trends in Maine's economy, population, and land development, must be continually monitored to track their direction and anticipate future conditions. Future patterns in these trends will guide future changes in the transportation system and the roles that the various transportation modes play in that system. The recommendations for the I-295 Corridor must provide a path that gives it the flexibility necessary to meet the needs of the traveling public, however that future unfolds.

Near-term recommendations must respond to immediate needs, but they should also be compatible with at least three future scenarios: one that requires the management of the Corridor as safely and efficiently as possible in a climate of scarce funds, one that requires an adequate response to move people and goods in an expanding economy, and one that requires the Corridor to adapt to an era of higher energy costs and greater environmental stewardship.

Long-term recommendations must be able to lead the Corridor down a path to any of these three scenarios, which will become clearer as future trends emerge. It is possible that the future of the I-295 Corridor will contain elements of all of these scenarios.

B. Near-Term Improvements

The following pages summarize the near-term improvement recommendations for the I-295 Corridor Study. These recommendations consist of ITS, interchange, and auxiliary lane improvements to address some of the problematic locations that can be addressed by reasonably affordable actions. For each of the near-term improvements, the location, problems, recommended action, benefits, challenges, coordination needs, and status are identified.

A review of the near-term improvements shows that several of the recommendations are already funded for design and construction. Many will be completed in the next four years in coordination with an I-295 rehabilitation effort underway to maintain the physical condition of the pavement, guardrail, signs and bridges in the Corridor.

Table 5.1: I-295 Corridor Study Recommendations

Strategies	I-295 Recommendations	
	Near Term (1 to 6 years)	Long Term (6 to 20 years)
Intelligent Transportation Systems (ITS)	Variable Message Sign Improvements (Portland & S. P.) \$1M	Continue Freeway Management Improvements (corridor-wide)
Auxiliary Lane Improvements	SB Auxiliary Lane Exit 4 to 3 (S.P.) \$3M NB Auxiliary Lane Exit 3 to 4 (S.P.) \$4M NB On-ramp Impr. Exit 11 (Falmouth) \$2M Aux. Lane & Off-ramp Impr. Exit 7 (Portland) \$2M	Complete Acceleration/Deceleration Ramp Improvements (Falmouth to Freeport) \$7M
Transportation Demand Management (TDM)	Consider Toll Strategies to Manage and Improve Mobility in I-295 Corridor \$??	
Commuter Transit Services	Consider Commuter Rail Yarmouth to Portland \$10-30M	Expanded Commuter Rail to Portland \$30-60M
Interchange Improvements	SB Ramp Improvements Exit 15 (Yarmouth) \$5M Off-Ramp Improvements Exit 6 (Portland) \$1M	NB Ramp Improvements Exit 15 (Yarmouth) \$5M Interchange Access Improvements Exit 4 (S. Portland) \$6M NB & SB Thru Lanes Exits 5 - 6 - 7 (Portland) \$20M Interchange Access Improvements Exit 11 (Falmouth) \$35M
Added Highway Capacity	I-95 (Turnpike) Capacity Impr. (S. P. - Portland) \$75M	
	Monitor Corridor Conditions and Update Plans as Needed (corridor-wide)	
		NB & SB Thru Lanes Exits 2 - 9 (S. P. - Portland) \$50M NB & SB Thru Lanes Exits 11 - 15 (Fal.-Cumb.-Yar.) \$18M
	High Priority Project Funding Monitor Needs & Update Plans Traffic Diversion Strategy Capacity Increase Contingency Strategy	

Near-Term Strategy: Intelligent Transportation Systems

Project: Interstate Highway Management System – First Phase

City/Town: Scarborough to Falmouth

Location: I-295, I-95, and Falmouth Spur

Problem: I-295 has the highest Annual Average Daily Traffic volumes of any highway in Maine. While most segments of I-295 operate effectively most of the time, incidents including vehicle crashes, vehicle breakdowns, stalled vehicles, and roadway debris compromise its capacity and safety. Reductions in capacity caused by these incidents result in extreme congestion or major safety hazards, especially during times of high-volume travel or inclement weather. Long backups of traffic have huge costs in terms of delay to users and wasted fuel and greatly increase the threat of crashes.

Recommended Action: Plan and develop an initial phase toward an Interstate highway management system that continually monitors operating conditions on the Interstate highways, promptly reports incidents to responders, alerts motorists to deteriorated conditions ahead, and provides for the prompt resolution of incidents. Focus initial attention on the Scarborough to Falmouth segments of I-295 and I-95 where traffic volumes are highest and the opportunities for using controlled-access highways as alternate routes are the greatest. The first phase would consist of installing variable message signing at strategic inbound locations in Portland and South Portland, and coordinating their use with existing variable message signs constructed by the Maine Turnpike Authority on I-95 and on I-295 southbound, north of the Falmouth Spur.

Benefits:

- Motorists will have better information on traffic conditions that lie ahead. They will be able to make better choices about the routes they can take to avoid congested areas. By reducing traffic entering congested areas, the highway system will operate more efficiently.

Challenges and Coordination Needs:

- An Interstate highway management system in the Greater Portland area must be a multi-agency cooperative effort by MaineDOT, the Maine Turnpike Authority, the Maine State Police, local government, and other related services. A control system with protocols for managing information and operations needs to be established.
- New variable message signs and agency coordination must be funded and maintained.

Status: Permanent variable message signs in Portland and South Portland to be constructed and operating in 2010.

Near-Term Strategy: Auxiliary Lanes

Project: Exit 4-3 Southbound Auxiliary Lane Improvements

City/Town: South Portland

Location: I-295, Exit 4 to Exit 3

Problem: I-295 southbound between Exits 4 and 3 is one of the highest volume two-lane segments of interstate highway in Maine. Annual Average Daily Traffic is approximately 38,000 vehicles per day, with PM peak-hour traffic volumes of 4000 vehicles per hour. Due to the limited highway capacity, the inadequate acceleration and deceleration lengths of the ramps, and the high volume of weaving and non-weaving traffic, this location is now chronically congested during the PM peak period and operates at level of service F. The resulting congestion has created a High Crash Location with a high rate of rear-end crashes on I-295 Southbound between Exits 5 and 4, where traffic backups frequently occur.

Recommended Action: Construct a southbound auxiliary lane along the right shoulder of I-295 between Exits 4 and 3 and a second lane for the Exit 3 southbound off-ramp. Improve lighting as appropriate in the auxiliary lane area.

Benefits:

- The addition of the auxiliary lane will relieve the capacity constraints at this location, increase the effective acceleration and deceleration lengths of the ramps, improve the efficiency of weaving traffic movements, and the level of service.
- The addition of a second lane for the off-ramp will further improve weaving characteristics and the level of service.
- The rate of crashes at the Exit 4 on-ramp will be reduced.
- The 2025 level of service in the PM peak hour will improve from F to E.

Challenges and Coordination Needs:

- Wetland permitting will be needed along the stream on the west side of I-295 to accommodate the auxiliary lane.
- Two lanes of southbound traffic should be maintained on I-295 during daytime hours of the construction period. The median area could be developed as a detour area (for southbound or northbound traffic).
- Any lighting improvements should be compatible with airport requirements and abutting land uses.
- MaineDOT's Traffic Engineering Division maintains permanent counting equipment in this area.
- A permanent variable message sign for I-295 northbound is planned to be constructed in this area.
- At Portland-area public meetings, residents on the east (northbound) side of I-295 in South Portland have raised noise concerns.

Status: Constructed in 2009, with noise wall on east side.

Near-Term Strategy: Auxiliary Lanes

Project: Exit 3-4 Northbound Auxiliary Lane Improvements

City/Town: South Portland

Location: I-295, Exit 3 to Exit 4

Problem: I-295 northbound between Exits 3 and 4 is one of the highest volume two-lane segments of interstate highway in Maine. Annual Average Daily Traffic is approximately 38,000 vehicles per day, with AM peak-hour traffic volumes of 3600 vehicles per hour. Due to the limited highway capacity, the inadequate acceleration and deceleration lengths of the ramps, and the high volume of weaving and non-weaving traffic, this location is now often congested during the AM peak period and operates at level of service E.

Recommended Action: Construct a northbound auxiliary lane along the right shoulder of I-295 between Exits 3 and 4. Improve lighting as appropriate.

Benefits:

- The addition of the auxiliary lane will relieve the capacity constraints at this location, increase the effective acceleration and deceleration lengths of the ramps, improve the efficiency of weaving traffic movements, and improve the level of service.
- The addition of a second lane for the off-ramp will further improve weaving characteristics and the level of service.
- The rate of crashes at the Exit 4 on-ramp will be reduced.
- The 2025 level of service in the AM peak hour will improve from F to E.

Challenges and Coordination Needs:

- Although not part of the construction scope of this project, the project should be designed to accommodate a possible future off-ramp to Route 1 Southbound at Exit 4 and other planned access improvements at this interchange. The off-ramp would involve right-of-way acquisition and a structure over a railroad mainline.
- Two lanes of northbound traffic should be maintained on I-295 during daytime hours of the construction period.
- Any lighting improvements should be compatible with airport requirements and abutting land uses.
- MaineDOT's Traffic Engineering Division maintains permanent counting equipment in this area.
- A permanent variable message sign for I-295 northbound is planned to be constructed in this area.
- At Portland-area public meetings, residents on the east (northbound) side of I-295 in South Portland have raised noise concerns.

Status: Constructed in 2009, with noise wall on east side.

Near-Term Strategy: Auxiliary Lanes

Project: Exit 7 Off-Ramp and Auxiliary Lane Improvements

City/Town: Portland

Location: I-295, Exit 7 (Franklin Arterial)

Problem: The single-lane northbound and southbound off-ramps at I-295 Exit 7 carry a combined AADT of 12,000 vehicles per day and an AM peak-hour volume of 1700 vehicles. The unsignalized junction of these two off-ramps becomes congested to the point where vehicles queue up on both ramps and encroach on the I-295 mainline. Routinely, northbound off-ramp traffic queues up side-by-side on the one-lane ramp. An additional problem area is the short two-lane cross-section on the southbound mainline between Exit 8 and the Exit 7 off-ramp. This segment of I-295 has AM peak-hour volumes that approach 4000 vehicles and operates at level of service E.

Recommended Action: Construct an auxiliary lane to relieve the southbound two-lane constriction between Exit 8 and Exit 7 and a second lane on both the northbound and southbound off-ramps. At the intersection of the two off-ramps, install a traffic signal coordinated with the signal at the Franklin/Marginal Way intersection. At the Franklin/ Marginal Way intersection, provide a four-lane approach from the ramp intersection.

Benefits:

- Congestion will be reduced on both off-ramps, resulting in shorter queues and greater safety for off-ramp and mainline traffic.
- On the southbound mainline between Exits 8 and 7, the 2025 level of service in the AM peak hour will improve from F to E.

Challenges and Coordination Needs:

- The widened southbound off-ramp should remain compatible with the pedestrian/ bicycle path along Back Cove. The closeness of the southbound off-ramp to the southbound on-ramp and the pedestrian/bicycle path along Back Cove may require a retaining wall treatment to accommodate the second lane of the ramp.
- The project should consider the potential for a future pedestrian link between the Franklin-Marginal intersection and the path along Back Cove. The safety of the location for this purpose should be monitored.
- The project should be designed for compatibility with a proposed rail line located parallel to and between I-295 and Marginal Way and with possible future changes in the layout of Franklin Arterial, now in a planning study.
- In the long term, the north leg of Marginal Way and certain left turn movements may be eliminated at this intersection per an agreement between MaineDOT and the City of Portland. This agreement also calls for monitoring of I-295 mainline traffic conditions on the approaches of both Exit 7 off-ramps.

Status: In preliminary design. Funded for construction in 2010.

Near-Term Strategy: Auxiliary Lanes

Project: Exit 6 Loop Off-Ramp Improvements

City/Town: Portland

Location: I-295, Exit 6 (Forest Avenue)

Problem: The two loop off-ramps at I-295 Exit 6 (northbound-to-westbound and southbound-to-eastbound) terminate on Forest Avenue at an acute (shallow) angle. Forest Avenue, at these points, maintains three travel lanes in each direction. The acute angle allows off-ramp traffic to merge with Forest Avenue traffic at excessive speeds, but the high volumes on Forest Avenue, with an AADT over 35,000 vehicles per day, makes smooth entry from the off-ramps difficult. Vehicles slowing or stopping before entering Forest Avenue are vulnerable to being rear-ended by another vehicle on the off-ramp. The result is that both off-ramp termini are High Crash Locations with a high number of rear-end crashes. Each location has experienced 50 or more crashes in a 3-year period. In addition to the damages and injuries that can occur, traffic flow at Exit 6 can be severely disrupted as traffic on the off-ramp queues back to the I-295 mainline. The presence of bicycle and pedestrian traffic at the location further complicates the problem.

A lesser off-ramp issue at Exit 6 is the northbound-to-eastbound off-ramp at Forest Avenue. Often, long queues develop as vehicles wait for opportunities to enter Forest Avenue. However, the queues typically do not interfere with I-295 northbound mainline traffic flow and the entry point to Forest Avenue is not a High Crash Location.

Recommended Action: Realign the ends of the two loop off-ramps to Forest Avenue and modify the curb lines on Forest Avenue to reduce ramp speeds at the ramp termini and to provide protection for vehicles entering Forest Avenue from the off-ramps. For the northbound-to-eastbound off-ramp, conduct preliminary engineering for potential addition of a second lane and traffic signal control at Forest Avenue.

Benefits:

- Modifications at the loop off-ramp termini will improve traffic safety by reducing crash frequencies at the loop off-ramp termini. This, in turn, will result in less traffic congestion on I-295 due to traffic flow disruptions at the ramps.
- Pedestrian safety through the Exit 6 area will be improved by the reduction in speeds on the loop off-ramps and the shortening of the crosswalks at the ramp termini.
- The signalization and added vehicle storage for the northbound-to-eastbound off-ramp will reduce the length of queues on the ramp.

Challenges and Coordination Needs:

- Accommodation for pedestrians and bicyclists along Forest Avenue should be maintained. Provision of a bike lane between the relocated Forest Avenue curb line and the sidewalk could improve protection for bicyclists while eliminating

the need to relocate drainage structures. Crosswalks at the ends of the off-ramps can be shortened.

- The signalization of the northbound-to-eastbound off-ramp would require coordination with eastbound Forest Avenue traffic flow. The scope of this improvement should not include breaking access controls that prevent off-ramp traffic from making an eastbound left turn onto Marginal Way, due to the likelihood that this left turn traffic would queue up enough to interfere with eastbound thru traffic on Forest Avenue. Break of access control as described above has been proposed in the Portland Peninsula Plan – Draft Final Report.
- The improvement should be designed to be compatible with the potential rehabilitation of a rail line parallel to and between I-295 and Deering Oaks Park. The rail line also has the potential to cross Forest Avenue at grade between I-295 and Marginal Way. If this railroad crossing were to be built, the signalized northbound off-ramp would become part of the traffic signal system for the at-grade crossing.

Status: Funded for design and construction in 2010.

Near-Term Strategy: Auxiliary Lanes

Project: Exit 11 Northbound On-Ramp Improvement
City/Town: Falmouth
Location: I-295, Exit 11 (Maine Turnpike Falmouth Spur)

Problem: The northbound on-ramp from the Falmouth Spur to I-295 adds an AADT of 5000 vehicles per day to the 23,000 AADT on I-295 northbound. The on-ramp has an inadequate acceleration lane and is inadequately spaced from the northbound Exit 10 on-ramp, located less than 700 feet upstream. On-ramp traffic is unable to safely reach mainline speed before merging with mainline traffic. The closeness of the Exit 10 on-ramp results in interference between vehicles using the two on-ramps and with thru traffic on I-295. The Exit 11 on-ramp currently operates at level of service D in the PM peak hour.

Recommended Action: Construct an acceleration lane approximately 1300 feet length parallel to the I-295 northbound mainline.

Benefits:

- Traffic entering I-295 northbound from the Exit 11 on-ramp will be able to merge with mainline traffic more smoothly and with much less interference.
- The acceleration lane also provides greater separation between vehicles using the two on-ramps. Entering traffic from Exit 10 will also benefit from improved safety.
- For the Exit 11 on-ramp, the 2025 level of service in the PM peak hour will be maintained at D or better.

Challenges and Coordination Needs:

- The horizontal clearance available under the Falmouth Spur bridge may require a design exception from FHWA for shoulder width.
- The closeness of ledge to the roadway may raise drainage and guardrail issues.
- Maintaining normal daytime traffic flow during construction may be difficult due to space constraints.
- In the long term, the configuration of Exits 11 and 10 may be altered. However, auxiliary lane improvements made in this project will fit into the long-term concept, which converts the acceleration lane for the off-ramp into a deceleration lane for a new northbound off-ramp to the Falmouth Spur.

Status: In preliminary design.

Near-Term Strategy: Interchange Improvements

Project: Exit 15 Southbound Interchange Improvement

City/Town: Yarmouth

Location: I-295, Exit 15 (Route 1)

Problem: The southbound on-ramp at Exit 15 in Yarmouth adds an AADT of 4000 vehicles per day to the 23,000 AADT on I-295 southbound. The straight alignment of on-ramp and its tangent approach to the downstream mainline of I-295 invites high-speed entry onto I-295 with little consideration for upstream I-295 traffic, which enters the ramp junction area on a curve. The on-ramp lacks a parallel acceleration lane. The result of these deficiencies is a High Crash Location at the ramp junction. This location currently operates at level of service D in the AM peak hour.

Recommended Action: Reconstruct the southbound on-ramp to provide a curved lower-speed alignment and a parallel acceleration lane approximately 1000 feet in length along I-295.

Benefits:

- The realigned southbound on-ramp will address the High Crash Location at the ramp junction with I-295.
- For the realigned southbound on-ramp, the 2025 level of service in the AM peak hour will improve from E to D.
- The realignment of the southbound on-ramp will create an opportunity for a park-and-ride lot along the St. Lawrence & Atlantic railroad line for potential commuter transit service.

Challenges and Coordination Needs:

- A recommended long-term improvement of Exit 15 in the northbound direction is the construction of a fourth interchange ramp, a northbound on-ramp, that would make Exit 15 a full-service interchange. The design of the northbound and southbound Exit 15 improvements should be coordinated, even if the construction of the southbound improvements precedes the construction of the northbound improvements.
- In the long term, there is the potential for added thru travel lanes on I-295 between Exit 11 and Exit 15. If additional lanes were to be constructed, portions of the added width of traveled way would be taken from the median and part from the outside shoulder. Ramp improvements at Exit 15 should take this potential into account as designs are developed so that the new ramps can serve the long-term need with minimal changes.
- At some public meetings, noise concerns about I-295 were raised by Yarmouth area residents.

Status: Funded for design and construction in 2012-13.

C. Long-Term Improvements

The long-term improvements to the I-295 Corridor draw from each of the six improvement strategies evaluated in the alternatives analysis:

- Intelligent Transportation Systems (ITS)
- Auxiliary Lane Improvements
- Transportation Demand Management (TDM)
- Commuter Transit
- Interchange Improvements
- Highway Capacity Increases

As with the near-term improvements, the location, problems, recommended action, benefits, challenges, coordination needs, and status of the long-term improvements are identified.

Unlike the near-term improvements, several of the long-term improvements require additional study to evaluate the economic and environmental feasibility before a project can be implemented. Some of the studies are already under way, but others are not yet scheduled or funded.

Also, two of the long-term improvements are identified as part of a “contingency” strategy of increased highway capacity should the coordinated strategy of low-cost improvements and I-295 traffic-reduction actions not prove sufficient to meet the long-term needs of the Corridor. Monitoring of I-295 conditions, improvement effectiveness, and external trends will be necessary to determine if adjustments to the recommendations are needed. Given the investments and the expected service life of current rehabilitation and near-term improvements, future capacity increases, if needed, are unlikely to be implemented within the next 15 years.

Long-Term Strategy: Intelligent Transportation Systems

Project: Interstate Highway Management System –Beyond the First Phase

City/Town: Scarborough to Brunswick

Location: I-295, I-95, and Falmouth Spur

Problem: I-295 has the highest Annual Average Daily Traffic volumes of any highway in Maine. While most segments of the highway operate effectively most of the time, highway incidents including vehicle crashes, vehicle breakdowns, stalled vehicles, and roadway debris compromise highway capacity and safety. Reductions in capacity caused by these incidents result in extreme congestion or major safety hazards, especially during times of high-volume travel or inclement weather. Long backups of traffic have huge costs in terms of delay to users and wasted fuel and greatly increase the threat of crashes.

Recommended Action: Building on the near-term first phase of ITS improvement, further develop an Interstate highway management system that continually monitors operating conditions on the Interstate highways, promptly reports incidents to emergency responders, alerts motorists to deteriorated conditions ahead, and provides for the prompt resolution of incidents. Interstate highway management will require systems capable of full-time detection of traffic volume and speed to monitor real-time conditions. The systems and protocols shared by MaineDOT, the Maine Turnpike Authority, the Maine State Police, and other entities will need to coordinate decisions, dispatch responders, and inform motorists. The use of these tools should minimize the duration and severity of incidents so that the interstate highways can perform to the best of their ability. Particular attention should be directed to improving monitoring capabilities on the Scarborough to Falmouth segments of I-295 and I-95 where traffic volumes are highest and the opportunities for using controlled-access highways as alternate routes are the greatest. A combination of traffic conditions detection and variable message signing will be important components to the Interstate highway management system. As part of the Interstate highway management system, plan and develop a service patrol for I-295, from Scarborough to Brunswick, to address incidents that do not require public safety responders.

Benefits:

- Incidents on the Interstate highway system will be detected sooner and be resolved more quickly by responding agencies. This will, in turn, reduce the traffic congestion and safety hazards caused by incidents.
- Motorists will have better information on traffic conditions that lie ahead. They will be able to make better choices about the routes they take to avoid congested areas. By reducing traffic entering congested areas, the highway system will operate more efficiently.
- With detectors to monitor traffic volumes and speeds, the MaineDOT will have better traffic information for monitoring highway operations and for planning to meet future highway needs.

Challenges and Coordination Needs:

- An Interstate highway management system in the Greater Portland area must be a cooperative effort by MaineDOT, the Maine Turnpike Authority, the Maine State Police, local government and other related services. A control system with protocols for managing information and operations needs to be established.
- An Interstate highway management system must be maintained. New facilities and services such as variable message signs, detection equipment, and service patrols must have sustained sources of funding.

Status: Unfunded and unscheduled.

Long-Term Strategy: **Auxiliary Lanes**

Project: Auxiliary Lanes at On- and Off-Ramps

City/Town: South Portland to Freeport

Location: I-295

Problem: Many on-ramps and off-ramps along I-295 have inadequate acceleration and deceleration lanes for existing and future traffic volumes. These lanes are too short to adequately allow vehicles to comfortably accelerate or decelerate between mainline speeds on I-295 and low speeds on the ramps. In the rural areas north of Portland, this results in on-ramps and off-ramps with a reduced level of service and reduced safety. In Portland and South Portland, where on-ramps and off-ramps are closely spaced, the on-traffic and off-traffic at these inadequate locations interfere with each other and produce a reduced-capacity weaving segment between the ramps. These weaving segments operate at a low level of service and may be a source of severe traffic congestion.

Recommended Action: Continue the upgrades of on-ramps and off-ramps from South Portland to Freeport to provide adequate acceleration and deceleration lengths between the highway-speed mainline of I-295 and the low-speed ramps. The added length of auxiliary lanes should be parallel to the mainline through lanes in these high-volume locations. Several of the ramps most in need of acceleration/deceleration lane improvement at Exits 3, 4, 7, 11, and 15 are addressed in the recommended interchange improvements or in the near-term auxiliary lane improvements. The remaining ramps in need of these improvements are located at Exits 10, 17, 20, 22, and 24 and listed in Tables 4.9 and 4.10.

Benefits:

- Levels of service will be improved at on-ramps and off-ramps.
- In the urban locations, levels of service and capacity on the weaving segments will be improved.
- Vehicular movements at the improved ramps will be safer. Merge movements at the on-ramps and diverge movements at the off-ramps will be accomplished more smoothly.

Challenges and Coordination Needs:

- Priorities should be set to ensure that auxiliary lane improvements are programmed in at the appropriate times. Factors that could assist in the prioritization include traffic volumes, crash history, magnitude of geometric deficiencies, and project coordination. Interstate Maintenance funds can be used for auxiliary lane improvements.

Status: Unfunded and Unscheduled.

Long-Term Strategy: Transportation Demand Management

Project: Detailed Feasibility Analysis of Differential Tolling

City/Town: Scarborough to Falmouth

Location: I-295, I-95, Falmouth Spur

Problem: Between Scarborough and Falmouth and points beyond, some through traffic uses I-295 through Portland and South Portland instead of using I-95 and the Falmouth Spur. The through traffic contributes to the heavier traffic congestion on the I-295. The Maine Turnpike tolls paid by through vehicles are the same for both routes.

Recommended Action: Support a detailed evaluation of the feasibility of establishing a differential toll for through vehicles that will encourage more through traffic traveling between Scarborough and Falmouth to use I-95 and the Falmouth Spur. If a feasible differential toll system can be designed, develop and execute an implementation plan. The feasibility evaluation would be a cooperative effort by the Maine Turnpike Authority, MaineDOT, and PACTS.

Benefits:

- A differential toll can divert through traffic away from I-295, improve the balance of traffic volumes between the two routes, and reduce overall traffic congestion on Interstate highways in Portland and South Portland.
- As a result of through traffic diversion, levels of service on I-295 between Scarborough and Falmouth can improve.

Challenges and Coordination Needs:

- Changes in the toll system can increase or decrease toll revenues. A feasible differential toll will need to be compatible with the financial responsibilities of MaineDOT and the Maine Turnpike Authority.
- Institutional obstacles exist to establishing tolls on non-Turnpike segments of the Interstate highway network. These obstacles will need to be overcome to fully implement differential tolls.
- Current layouts and toll structure of I-95 Exits 44 and 45 complicate the implementation of differential tolls between I-95 and I-295.
- Traffic impacts of differential tolls on arterial and collector streets need to be assessed.
- Emerging technologies in electronic toll collection, such as automated open-road tolling, may improve the feasibility of differential tolls.
- Existing traffic capacity on I-95 in Portland and South Portland could be a constraint on how much traffic could be diverted from I-295 to I-95.
- In addition to traffic diversion, changes in the toll system may have other objectives, such as increased revenue to fund transportation improvements.

Status: Some initial differential toll feasibility analysis has been undertaken jointly between MaineDOT and the Maine Turnpike Authority.

Long-Term Strategy: Commuter Transit

Project: Detailed Feasibility Analysis of Commuter Transit Service to Portland
City/Town: Greater Portland Area
Location: I-295 and I-95 Corridors

Problem: Every day, large numbers of commuters and other travelers use I-295 to reach their destination on the Portland Peninsula, the most densely developed part of the Greater Portland area. These travelers contribute to the traffic congestion on I-295 in Portland and South Portland, especially in the peak directions of travel during the AM and PM peak periods of the day.

Recommended Action: Evaluate the feasibility of building and operating a commuter transit service (rail or bus rapid transit) to the Portland Peninsula from outlying communities that rely on I-295 for access to this destination. Potential commuter transit corridors may originate from Brunswick in the north and Biddeford in the south. After feasible commuter transit options have been identified, identify a preferred option and develop a staged plan for implementing the preferred option.

Benefits:

- An effective commuter rail service would divert Portland-bound commuters from a congested I-295 during AM and PM peak periods of travel, reducing delays for the users of the commuter service as well as the travelers who continue to use I-295.
- As a result of commuter traffic diversion, levels of service on I-295 between Scarborough and Falmouth can improve, especially in the peak directions of travel during the a.m. and p.m. peak periods of the day.
- Vehicle-miles and vehicle-hours would be reduced. Therefore, emissions of air pollutants would be reduced.
- A shift in Portland-bound commuting from automobile to rail would reduce the demand for commuter parking on the Portland Peninsula, making land available for higher-value uses on a more pedestrian-friendly scale.

Challenges and Coordination Needs:

- Existing railroad lines (St. Lawrence & Atlantic Railroad and Pan-Am Railway) are potential commuter rail routes. MaineDOT now owns the right-of-way of the St. Lawrence & Atlantic from Yarmouth south to Portland, which may be adaptable to bus rapid transit (BRT). Use of any of these routes will require a cooperative arrangement with the host railroad and rail freight operations. Up grades to the guideway (track/roadway) and signals on these lines would be needed for commuter rail or BRT.
- Station facilities, including platforms, parking areas, and drop-off areas would be needed at stops along a route. Depending on the location of the commuter line, new bridge structures may be needed.

- Many of the upgrades to tracks, signals, and bridges could be completed as part of a project to extend Amtrak intercity passenger rail service from Portland to Brunswick.
- While commuter rail would be more effective in the long run than commuter bus in general traffic, buses could provide interim commuter service and feeder service to rail stations once commuter rail is established.
- If an exclusive right of way becomes available, bus rapid transit may be an effective commuter transit option.
- Commuter rail (and bus) services need a plan for meeting operating expenses.

Status: A commuter transit feasibility study to evaluate a new service from Portland north is under way.

Long-Term Strategy: Interchange Improvements

Project: Exit 4 Full-Service Interchange

City/Town: South Portland

Location: I-295, Exit 4 (Route 1)

Problem: Exit 4 is a partial-service interchange that does not have the capability to serve on-and-off traffic in both the northbound and southbound directions. This deficiency limits the effectiveness of this interchange in allowing traffic to use I-295 to avoid congested arterial streets in South Portland.

Recommended Action: Improve Exit 4 by adding a new northbound off-ramp and some modifications to existing ramps will allow I-295 northbound traffic to exit onto Route 1 southbound, and Route 1 northbound traffic to enter I-295 southbound.

Benefits:

- The improvements to Exit 4 will divert traffic from congested South Portland arterials such as Main Street and Broadway.

Challenges and Coordination Needs:

- A new northbound off-ramp will require acquisition of an oil storage tank and construction of a bridge over Pan Am Railways.
- Noise concerns have been raised by South Portland residents about traffic levels between Exits 3 and 4.
- Future improvements in bicycle and pedestrian facilities are anticipated in the Exit 4 area. The replacement of the Veterans Memorial Bridge between Portland and South Portland will include a shared-use bicycle/pedestrian facility between the two cities. Concepts for improved bicycle/pedestrian connections to the Maine Mall area have been proposed.

Status: Funded for preliminary engineering, which is in progress.

Long-Term Strategy: Interchange Improvements

Project: Added median lanes for Exit 6

City/Town: Portland

Location: I-295, Exit 5 to Exit 7

Problem: On a daily basis during peak hours, Exit 6 has a poor level-of-service performance along the I-295 mainline. The compact cloverleaf design of this interchange creates short high-volume weaving areas where through traffic, on-ramp traffic, and off-ramp traffic conflict. This conflict will result in higher levels of congestion at this interchange and greater likelihood of crashes as traffic volumes increase.

Recommended Action: Increase the number of travel lanes on I-295 between Exits 5, 6, and 7 from four lanes to six lanes by converting space in the median to an additional lane in each direction. The two inner lanes in each direction would be used by traffic not using Exit 6. The outer lane in each direction would be used by weaving traffic getting on or off I-295 at Exit 6. The use of median space for the added lane improves the safety and operation of the interchange while avoiding the right-of-way impacts and expense of making changes on the outside of the highway.

Benefits:

- The new median lanes will help shift through traffic on I-295 away from the on- and off-ramp areas of Exit 6 where conflicts with ramp traffic currently exist. The result will be improved levels of service and safety at the weaving areas and less traffic congestion.
- Levels of service and safety will also be improved on mainline segments between Exits 5, 6, and 7 and at ramp junctions of these interchanges.

Challenges and Coordination Needs:

- The median contains adequate width to add the two lanes without changes to the outside edge of the roadway. However, the shoulders in the narrower median would need to remain at their current width.
- These improvements may attract additional use of Exit 6 and lead to changes on Forest Avenue to accommodate the added traffic.
- Public input to date suggests that further development of the proposed improvement be treated as a project of substantial public interest.

Status: Unfunded and unscheduled.

Long-Term Strategy: Interchange Improvements

Project: Exit 11 Full-Service Interchange

City/Town: Falmouth

Location: I-295, Exits 11 and 10

Problem: Exit 11 is a partial-service interchange that does not have the capability to serve on-and-off traffic in both the northbound and southbound directions. This deficiency limits the effectiveness of these interchanges in allowing traffic to use I-295 to avoid congested arterial streets in Portland and Falmouth.

Recommended Action: Improve Exit 11 by adding a southbound on-ramp from the Falmouth Spur and a northbound off-ramp to the Falmouth Spur, and by upgrading the existing Falmouth Spur ramps.

Benefits:

- Exit 11 improvements will improve access between I-295 and the Maine Turnpike and provide new opportunities for using both facilities to reduce traffic on congested arterial streets such as Washington Avenue in Portland and Route 1 in Falmouth.
- Reduced traffic on Bucknam Road and Route 1 will improve mobility and safety for local motorists, bicyclists, and pedestrians.
- The area vacated by the relocated Exit 10 ramps creates an opportunity to locate a multimodal park-and-ride facility adjacent to I-295, Exit 10, and the St. Lawrence & Atlantic Railroad.

Challenges and Coordination Needs:

- A new northbound off-ramp to the Falmouth Spur would likely require the relocation of the existing northbound loop on-ramp. The relocated northbound ramp could be constructed as a flyover ramp over the Falmouth Spur and the I-295 mainline. A parcel of land that would be needed for the loop ramp is under development pressure, but MaineDOT has maintained access control to this parcel.
- A new southbound on-ramp from the Falmouth Spur will require relocation of the southbound on- and off-ramps at Exit 10. The new Exit 10 ramps would require additional right of way and grade separation under the St. Lawrence & Atlantic Railroad.
- Future development of Route 1 in Falmouth will need to be coordinated with the long-term right-of-way and access needs of Exit 11.

Status: Unfunded and unscheduled.

Long-Term Strategy: Interchange Improvements

Project: Exit 15 Full-Service Interchange

City/Town: Yarmouth

Location: I-295, Exit 15

Problem: Exit 15 is a partial-service interchange that does not have the capability to serve on-and-off traffic in both the northbound and southbound directions. This deficiency limits the effectiveness of these interchanges in allowing traffic to use I-295 to avoid congested Route 1 in Yarmouth.

Recommended Action: Improve Exit 15 by modifying the existing northbound off-ramp to Route 1 and adding a northbound on-ramp.

Benefits:

- Addition of a northbound on-ramp will divert traffic from Route 1 to I-295 and reduce the traffic load at Exit 17 intersections in Yarmouth.
- A full-service interchange will expand park-and-ride opportunities at this interchange.
- Modification of the existing northbound off-ramp will provide an improved deceleration lane.

Challenges and Coordination Needs:

- Modification of the existing northbound off-ramp can minimize the right-of-way impacts of a new northbound on-ramp.
- The near-term improvement of the existing southbound on-ramp will further improve park-and-ride opportunities by creating space for a park-and-ride facility adjacent to I-295, Route 1, and the St. Lawrence & Atlantic Railroad.
- Proposed modifications to Route 1 and Exit 17 in Yarmouth are on hold until the actual impact of a full-service Exit 15 on the traffic using those facilities has been assessed.
- Accommodation of bicycle and pedestrian facilities at the Route 1 crossing of I-295 at Exit 15 will be a long-term challenge.

Status: Funded for preliminary engineering, now under way.

Long-Term Strategy: Highway Capacity Increases

Project: Added through lanes on I-95 between Exits 44 and 53

City/Town: South Portland, Portland

Location: I-95 (Maine Turnpike), Exit 44 to Exit 53

Problem: Between Scarborough and Falmouth and points beyond, some through traffic uses I-295 through Portland and South Portland instead of using I-95 and the Falmouth Spur. The through traffic contributes to the heavier traffic congestion on I-295. Both I-95 and I-295 in Portland and South Portland are experiencing traffic volume growth and increasing congestion.

Recommended Action: Support the Maine Turnpike Authority (MTA) evaluation of an increase of the number of travel lanes on I-95 between Exits 44 and 53 from four lanes to six lanes by adding a lane in each direction on the outside of the existing roadway.

Benefits:

- Added capacity on I-95 can improve the level of service on I-95 in relation to I-295 and divert through traffic away from I-295. This would reduce I-295 traffic congestion and overall traffic congestion on Interstate highways in Portland and South Portland.
- As a result of through traffic diversion, levels of service on I-295 between Scarborough and Falmouth can improve.

Challenges and Coordination Needs:

- It is expected that the cost of widening I-95 in this area would be borne by the MTA.
- Consideration by MaineDOT and the MTA should be given to upgrading the design speed of the two existing I-295 ramps at Exit 11 to further enhance the attractiveness of using the Falmouth Spur and I-95 as the preferred route for through traffic between Scarborough and Falmouth.
- These improvements may attract additional use of I-95 in Portland and South Portland by local traffic as well.
- The effect of I-95 noise on abutting land uses may be an important environmental issue.

Status: MTA evaluation of the widening proposal is expected in the next five years.

Long-Term Contingency Strategy: Highway Capacity Increases

Project: Detailed feasibility evaluation of added through lanes on I-295 between Exits 2 and 9

City/Town: South Portland, Portland

Location: I-295, Exit 2 to Exit 9

Problem: Between Exits 2 and 9 are the highest traffic volumes on I-295. Locations on this part of I-295 will operate at worsening levels of service as volumes grow. The number of locations that have inadequate capacity to meet traffic demands would also grow.

Recommended Action: As warranted by observed future traffic conditions, evaluate the feasibility of an increase in the number of travel lanes on I-295 between Exits 2 and 9 from four lanes to six lanes.

Benefits:

- Adding capacity on I-295 can directly improve the level of service on the highway. This would reduce overall traffic congestion on Interstate highways in Portland and South Portland.

Challenges and Coordination Needs:

- Increasing the number of through lanes on I-295 in Portland and South Portland is not compatible with the coordinated strategy to reduce future traffic demand on I-295. Successful implementation of coordinated actions such as commuter transit, differential tolls, and Turnpike widening can minimize traffic volumes on I-295 so that additional through lanes are not required.
- Traffic volumes and operating conditions on I-295 should be monitored through an Interstate highway management system that will measure traffic volumes and congestion levels. Growing volumes and increased capacity problems may dictate a detailed evaluation of the addition of through lanes on I-295 in Portland and South Portland.
- These improvements may attract additional use of I-295 in Portland and South Portland.
- For most of Portland and South Portland, the I-295 median contains adequate width to add the two lanes without changes to the outside edge of the roadway as long as the shoulders in the narrowed median would need to remain at their current width. Exceptions to this exist at Exit 8 (Tukey's Bridge) and Exit 9 where narrow concrete medians and constraining on- and off-ramp locations severely impact the ability to add through lanes in those locations.

- South of Tukey's Bridge, the bridges that carry I-295 through Portland and South Portland have adequate substructure to support added width of the bridge decks to accommodate additional through lanes. The main exception to this would be the Fore River Bridge where added pier support would be needed in the median area.
- The effect of I-295 noise on abutting land uses may be an important environmental issue.

Status: Unfunded and unscheduled.

Long-Term Contingency Strategy:

Project: Detailed feasibility evaluation of added through lanes on I-295 between Exits 11 and 15.

City/Town: Falmouth, Cumberland, Yarmouth

Location: I-295, Exit 11 to Exit 15

Problem: Between Exits 11 and 15 are the highest traffic volumes on I-295 north of Portland. This part of I-295 will operate at worsening levels of service as volumes grow. The I-295 Corridor Study recommends a coordinated strategy of reducing traffic growth on I-295 to maintain an adequate level of service. However, if the actions to reduce traffic growth prove inadequate, a long-term contingency strategy should be followed.

Recommended Action: As warranted by observed future traffic conditions, evaluate the feasibility of an increase in the number of travel lanes on I-295 between Exits 11 and 15 from four lanes to six lanes.

Benefits:

- Adding capacity on I-295 can directly improve the level of service on the most heavily used segment of I-295 north of Portland.

Challenges and Coordination Needs:

- Increasing the number of through lanes on I-295 between Exit 11 and Exit 15 is not entirely compatible with the coordinated strategy to reduce future traffic demand on I-295. Successful implementation of coordinated actions such as commuter transit, differential tolls, and Turnpike widening can minimize traffic volumes on I-295 so that additional through lanes are not required.
- Traffic volumes and operating conditions on I-295 should be monitored through an Interstate highway management system that will measure traffic volumes and congestion levels. Growing volumes and increased capacity problems may dictate a detailed evaluation of the addition of through lanes on I-295 north of Exit 11.
- The median may not have adequate width to add the two lanes without changes to the outside edge of the roadway. However, existing right of way should be adequate for outside widening, if necessary.

Status: Unfunded and unscheduled.

Appendices

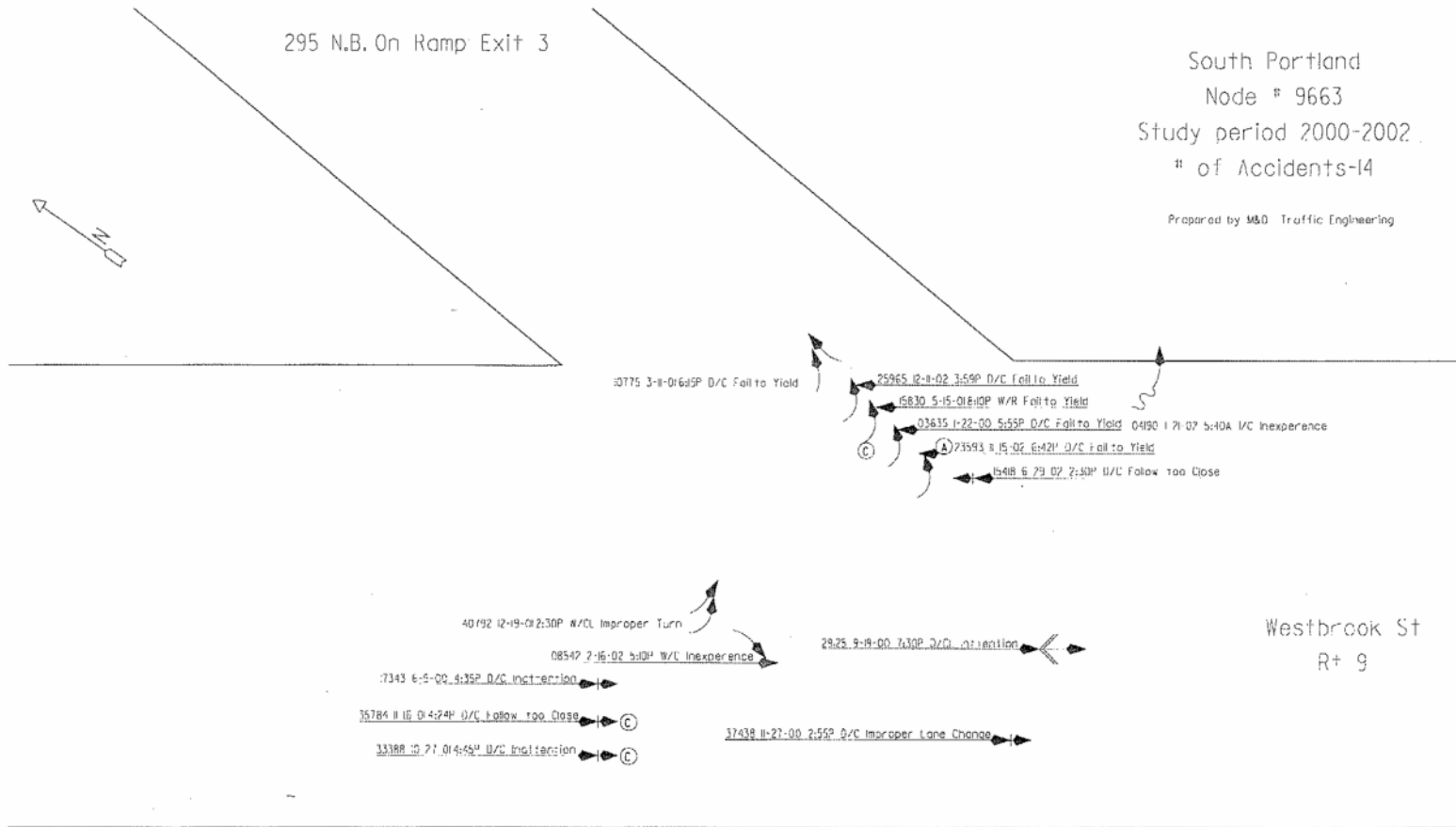

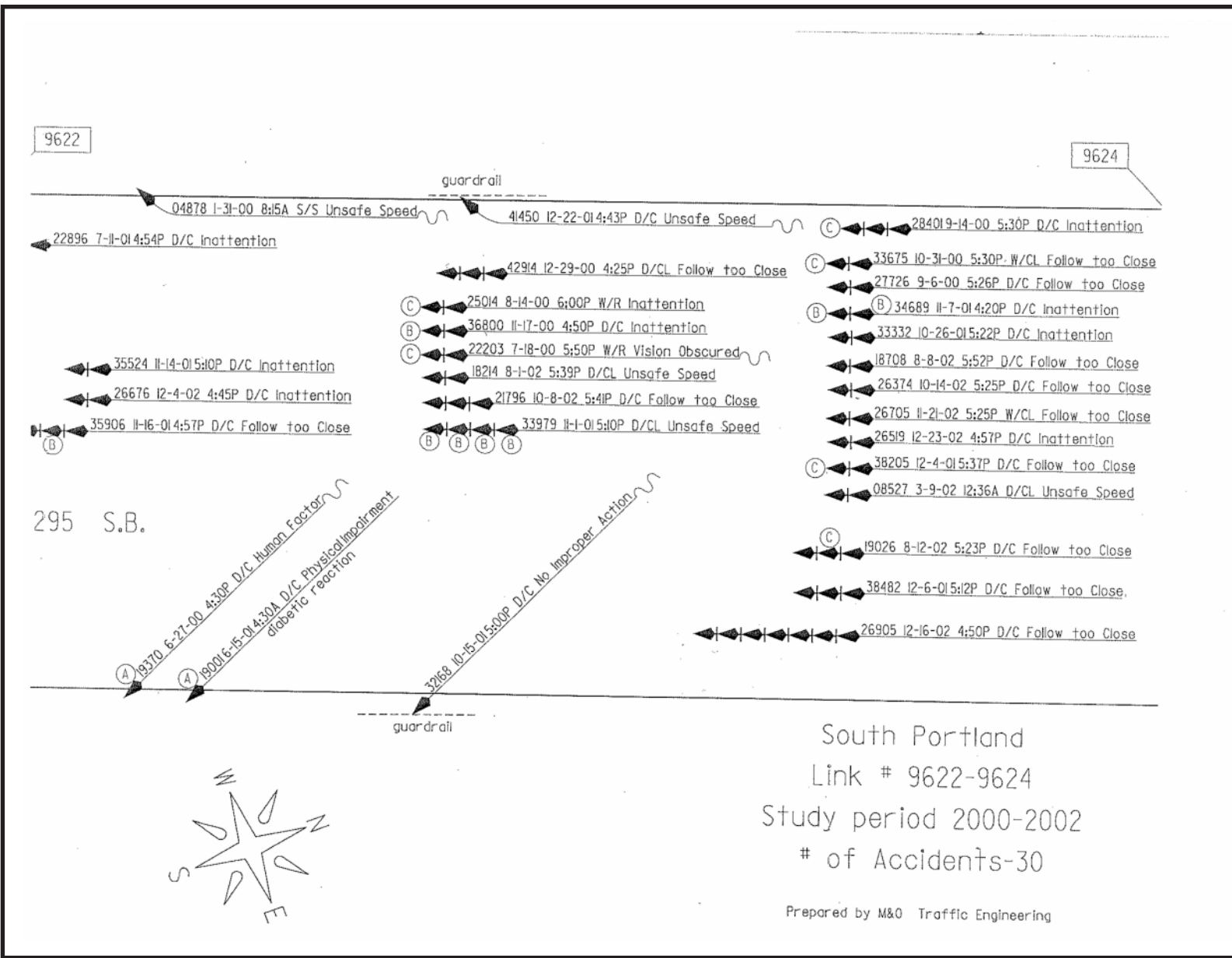

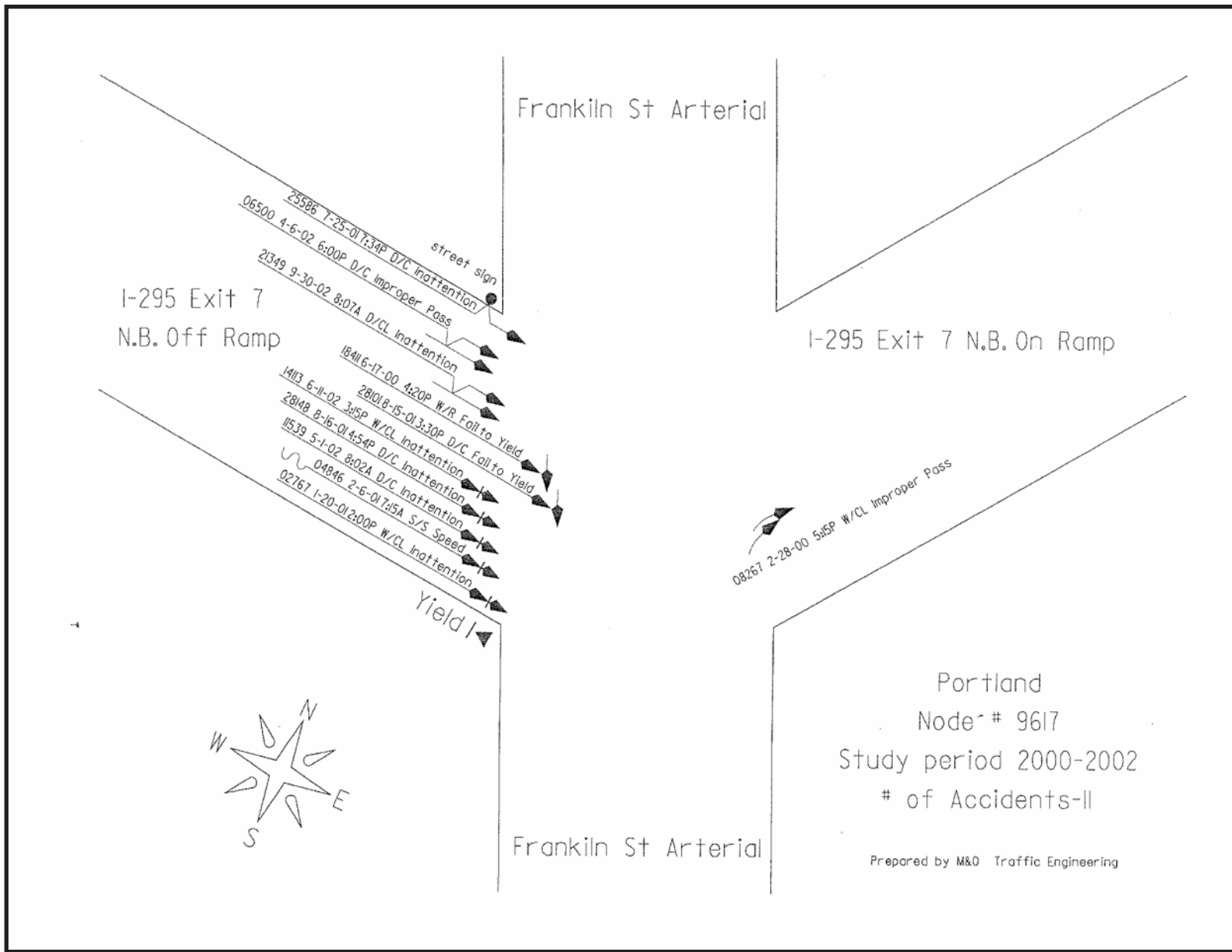

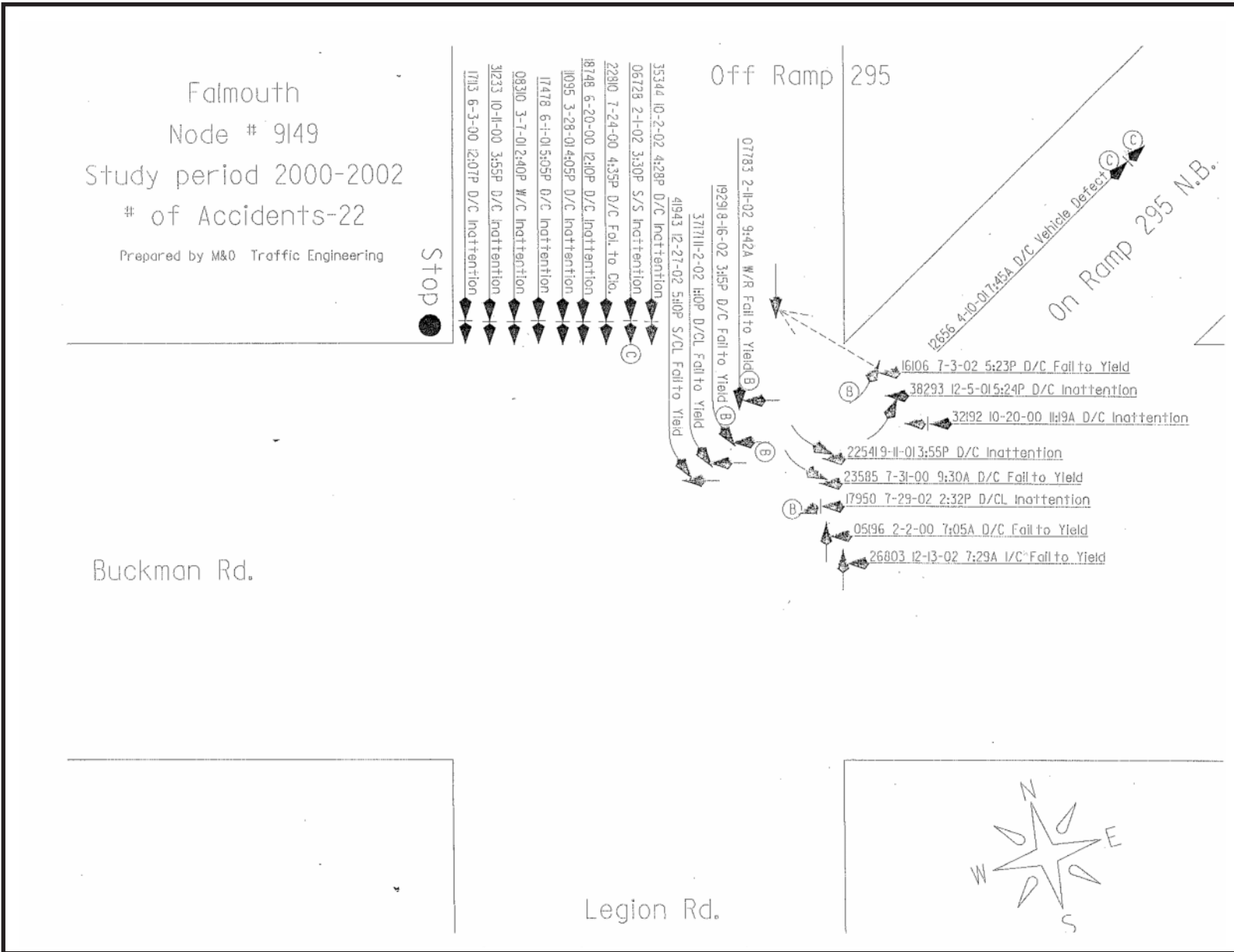

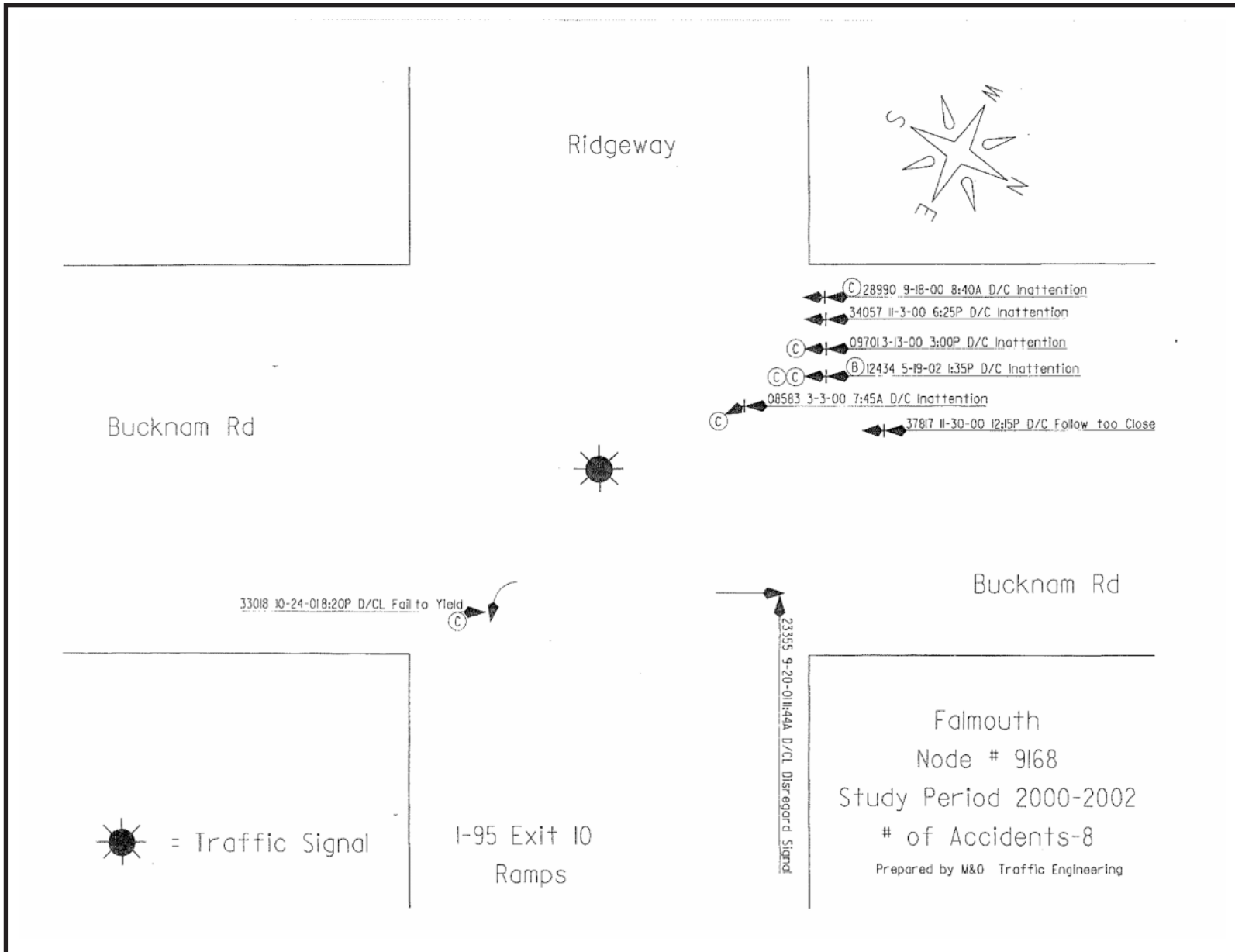

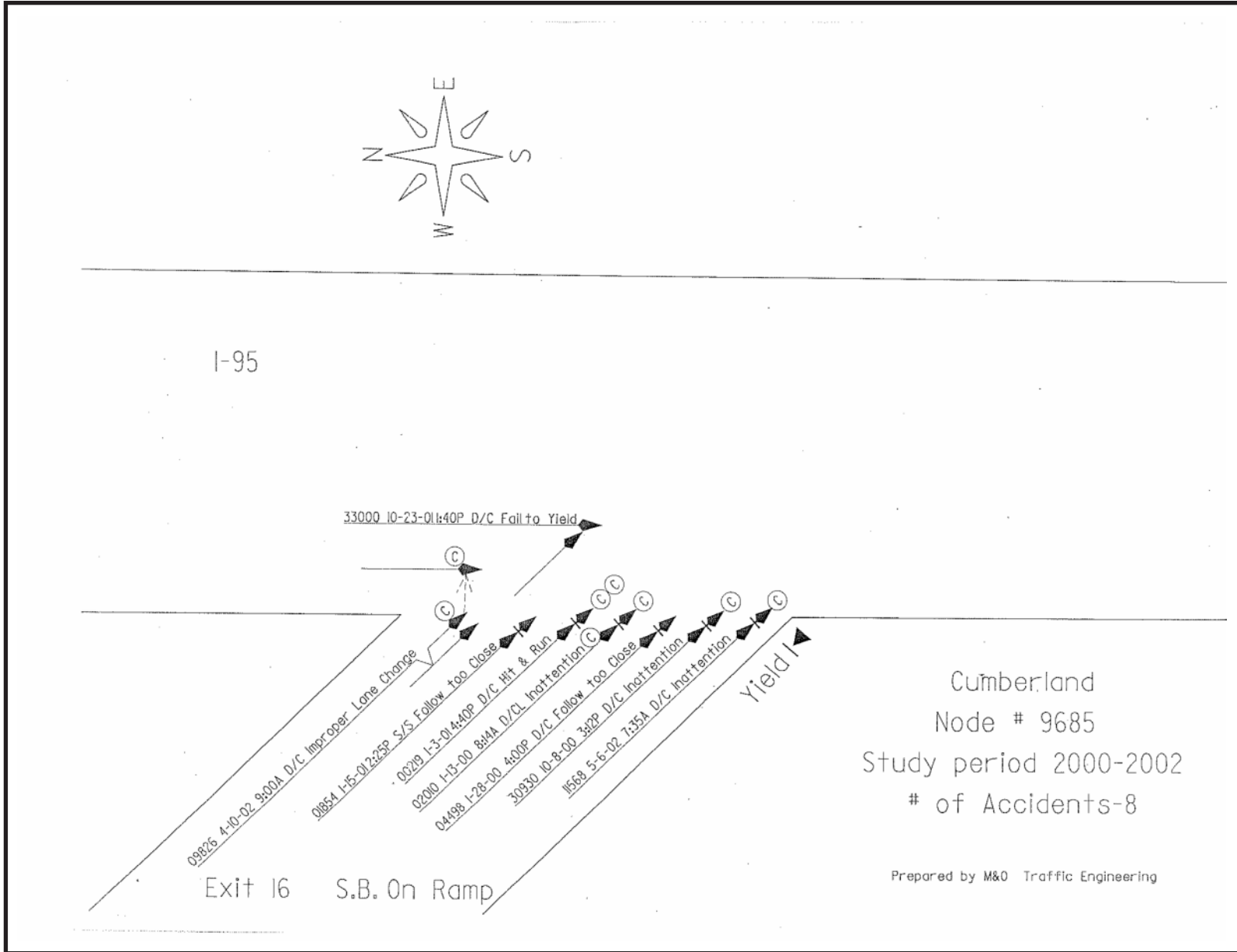

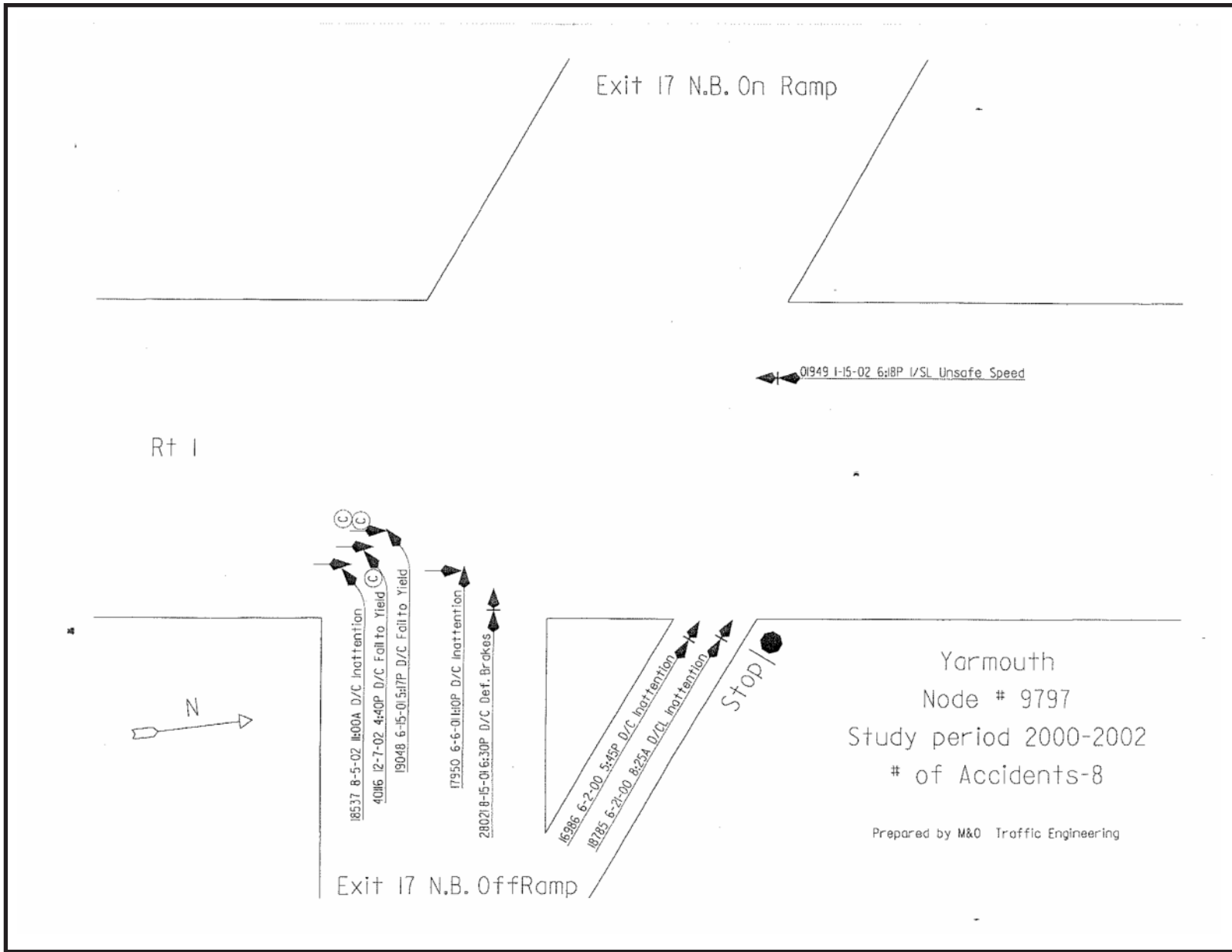

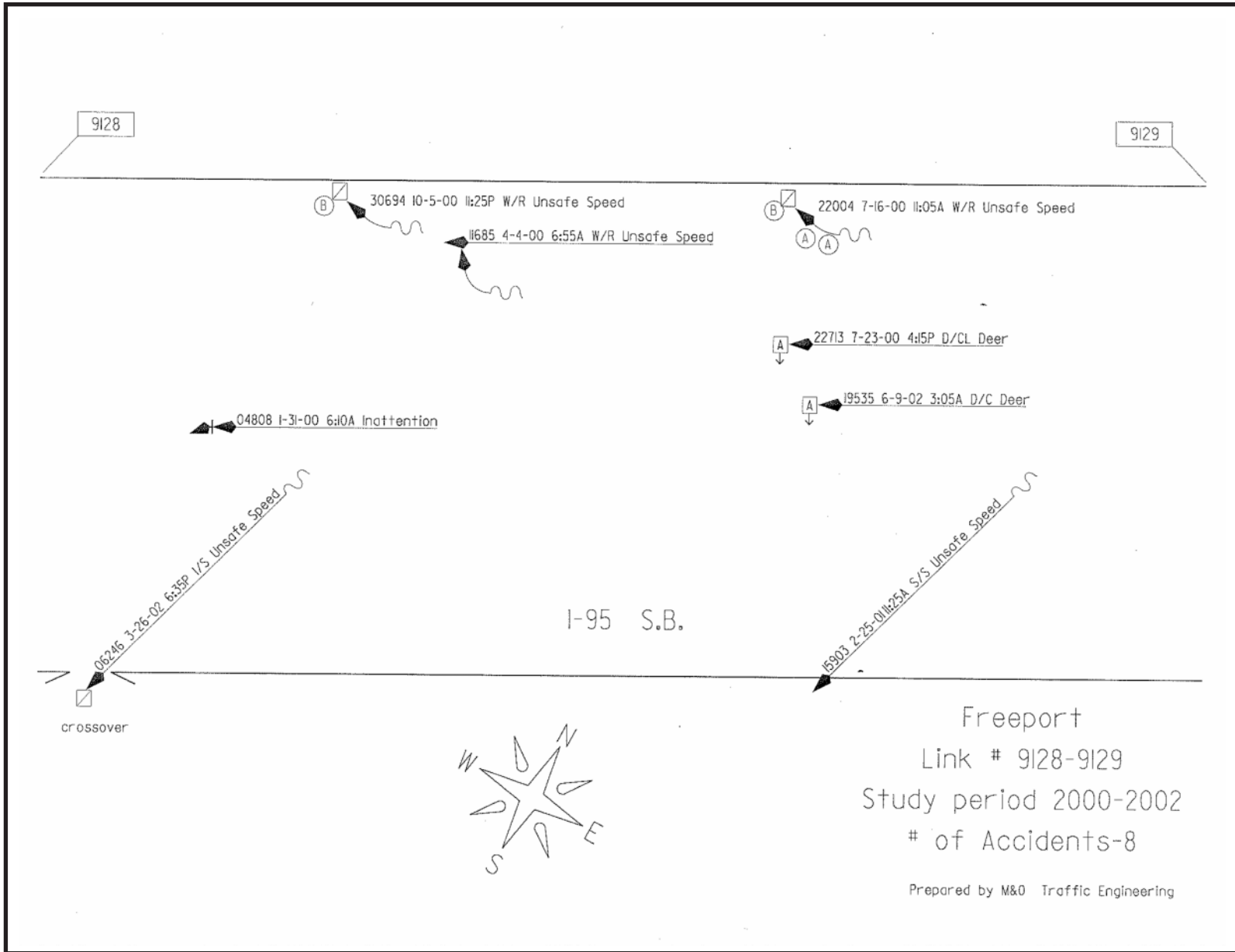

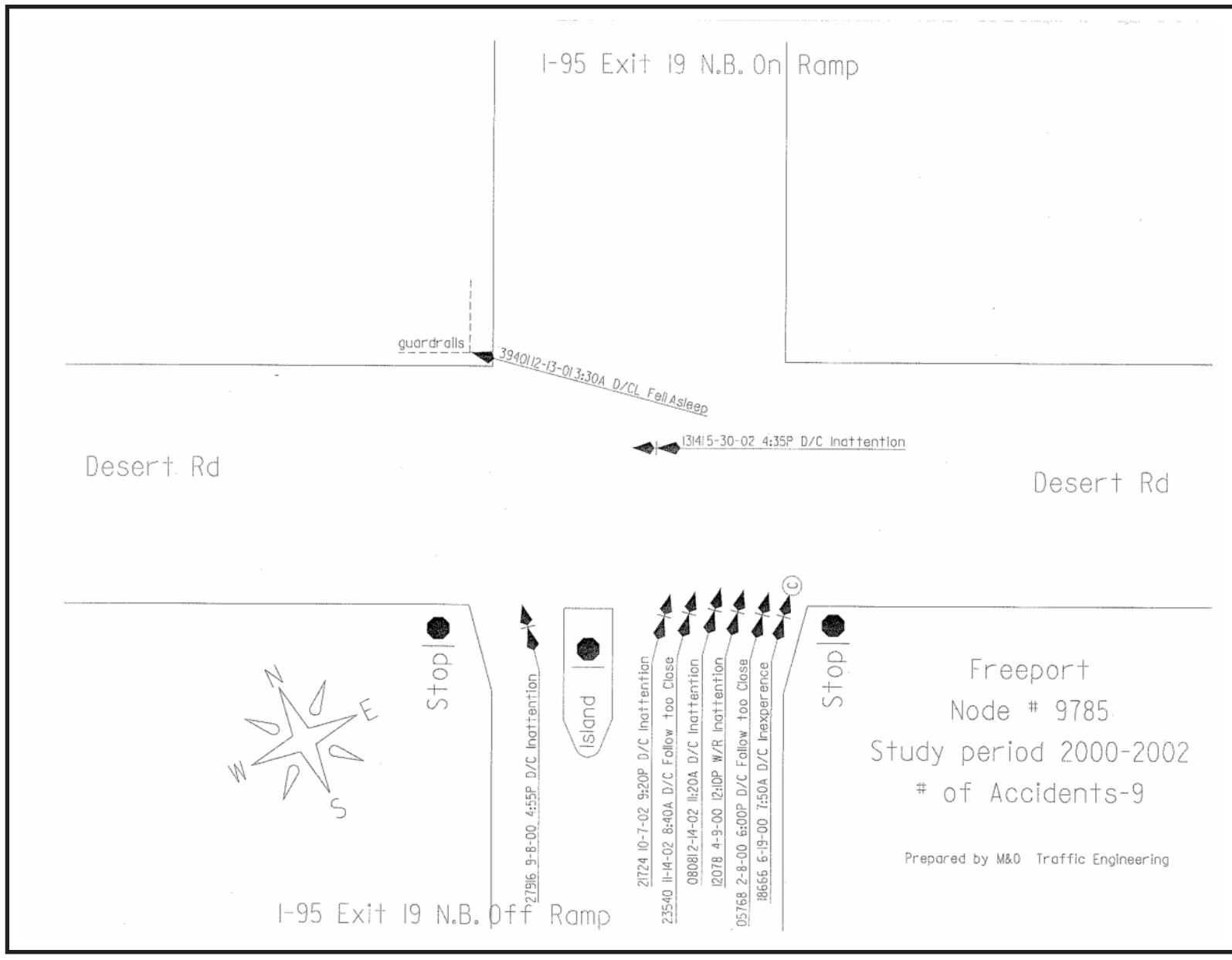

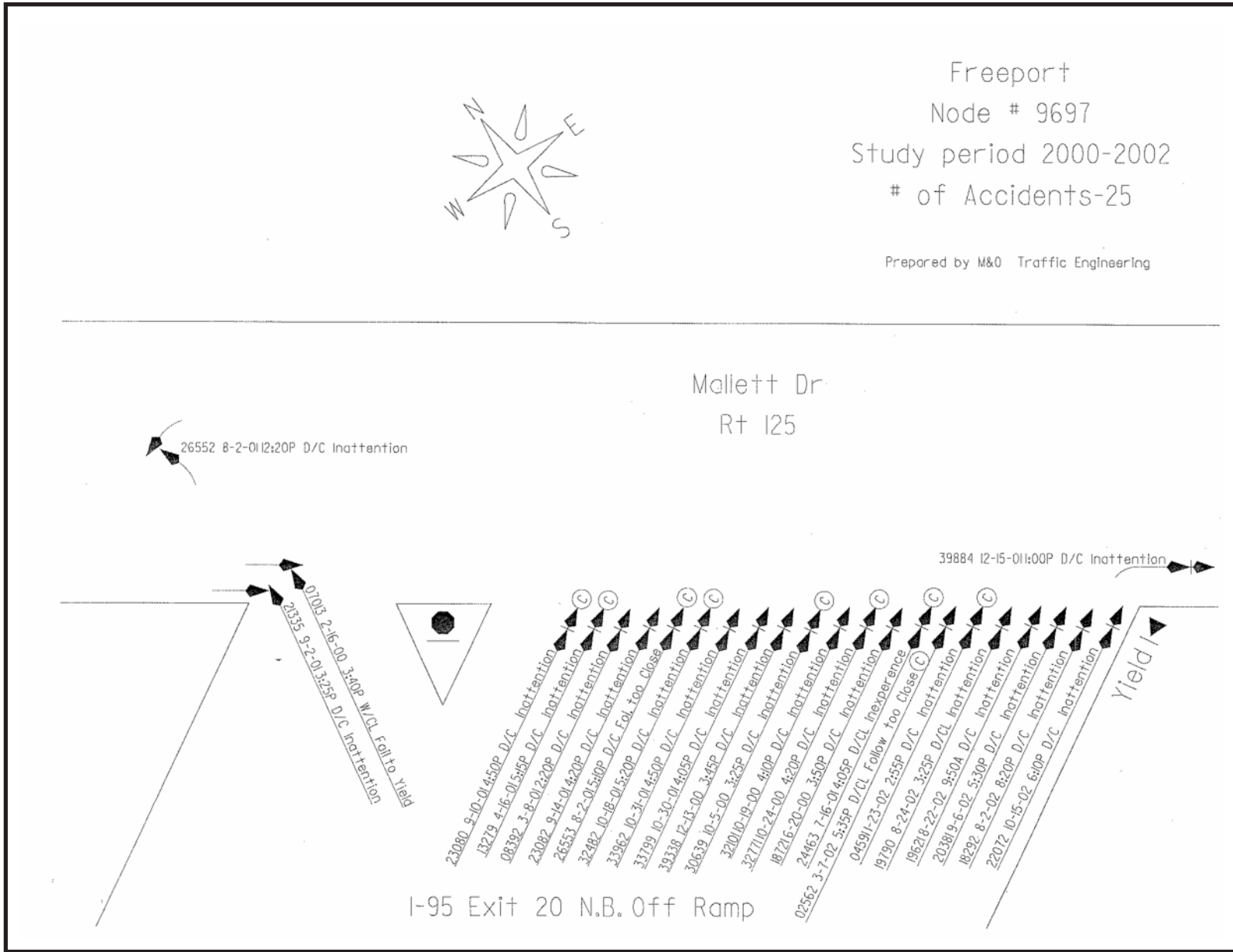

Appendix 2

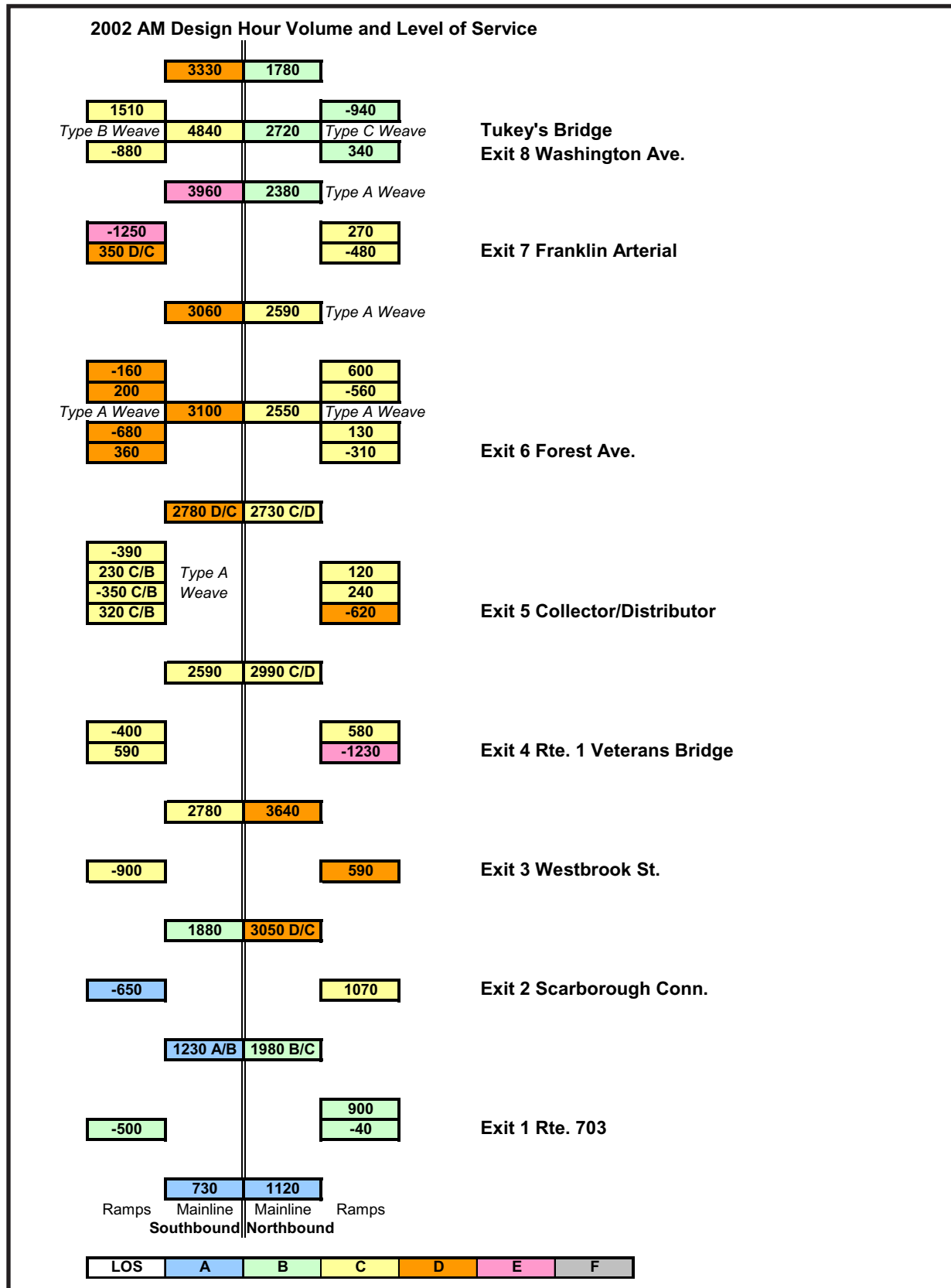

2002 AM Design Hour Volume and Level of Service

LOS	A	B	C	D	E	F
-----	---	---	---	---	---	---

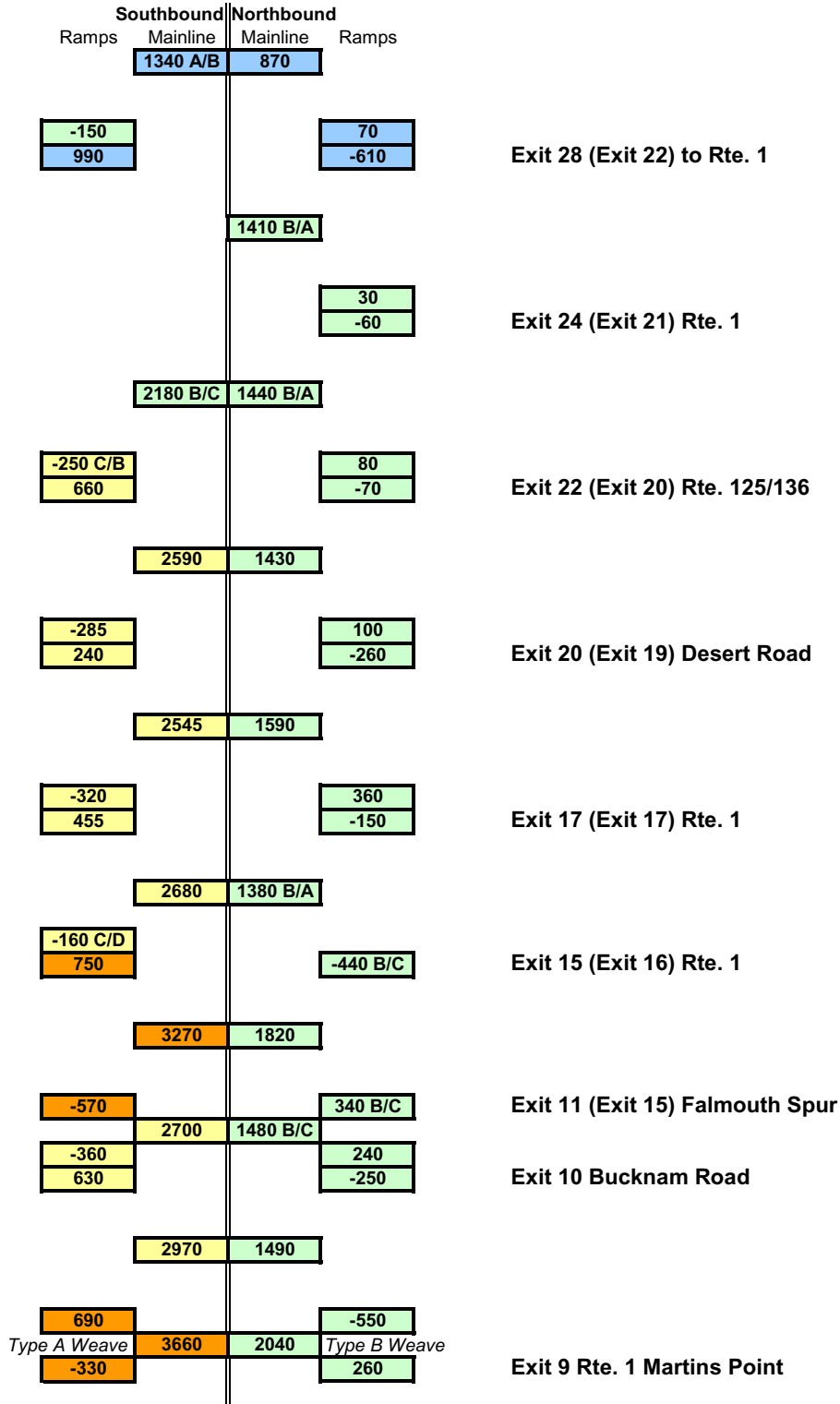

Appendix 3

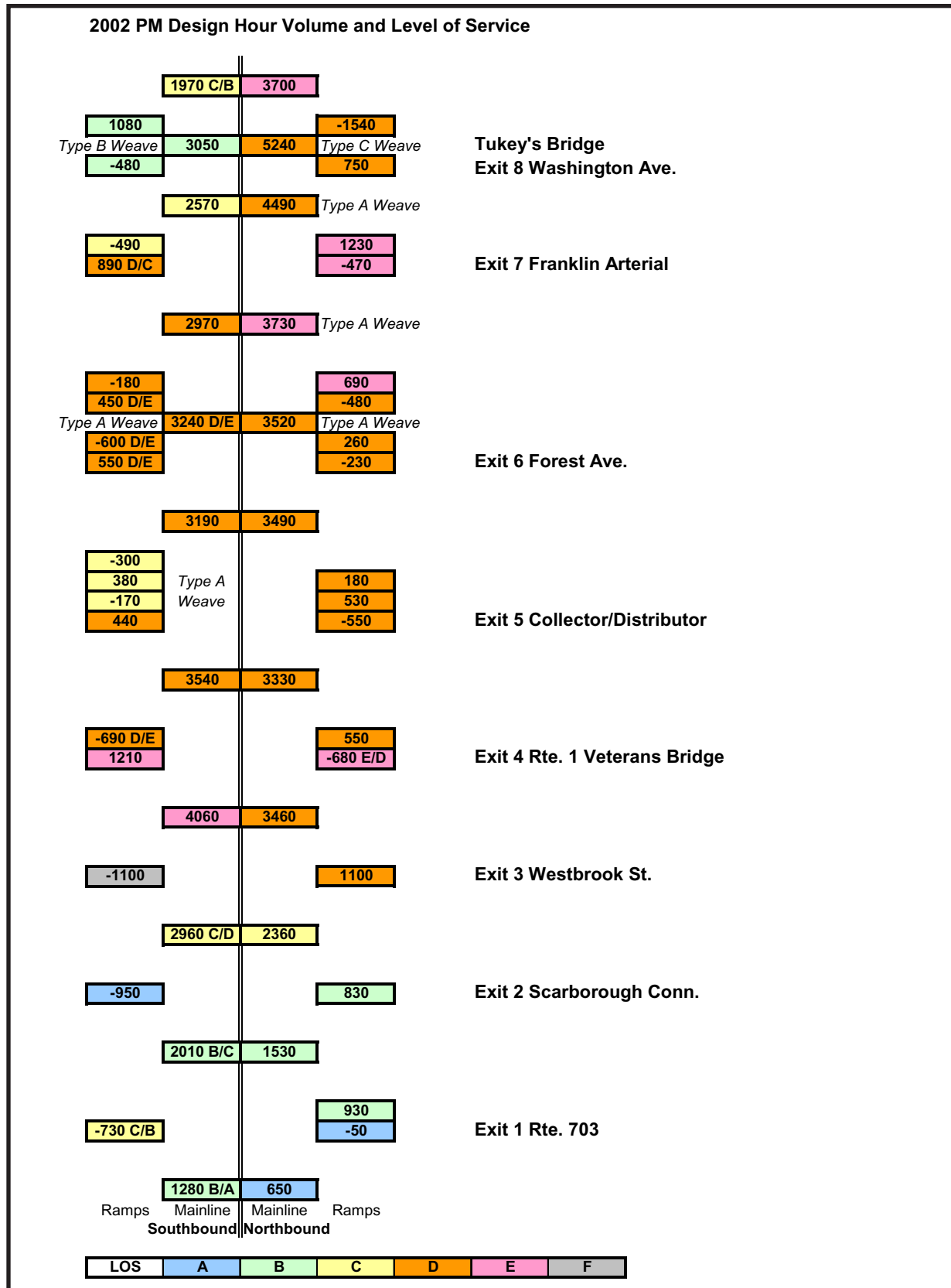

2002 PM Design Hour Volume and Level of Service

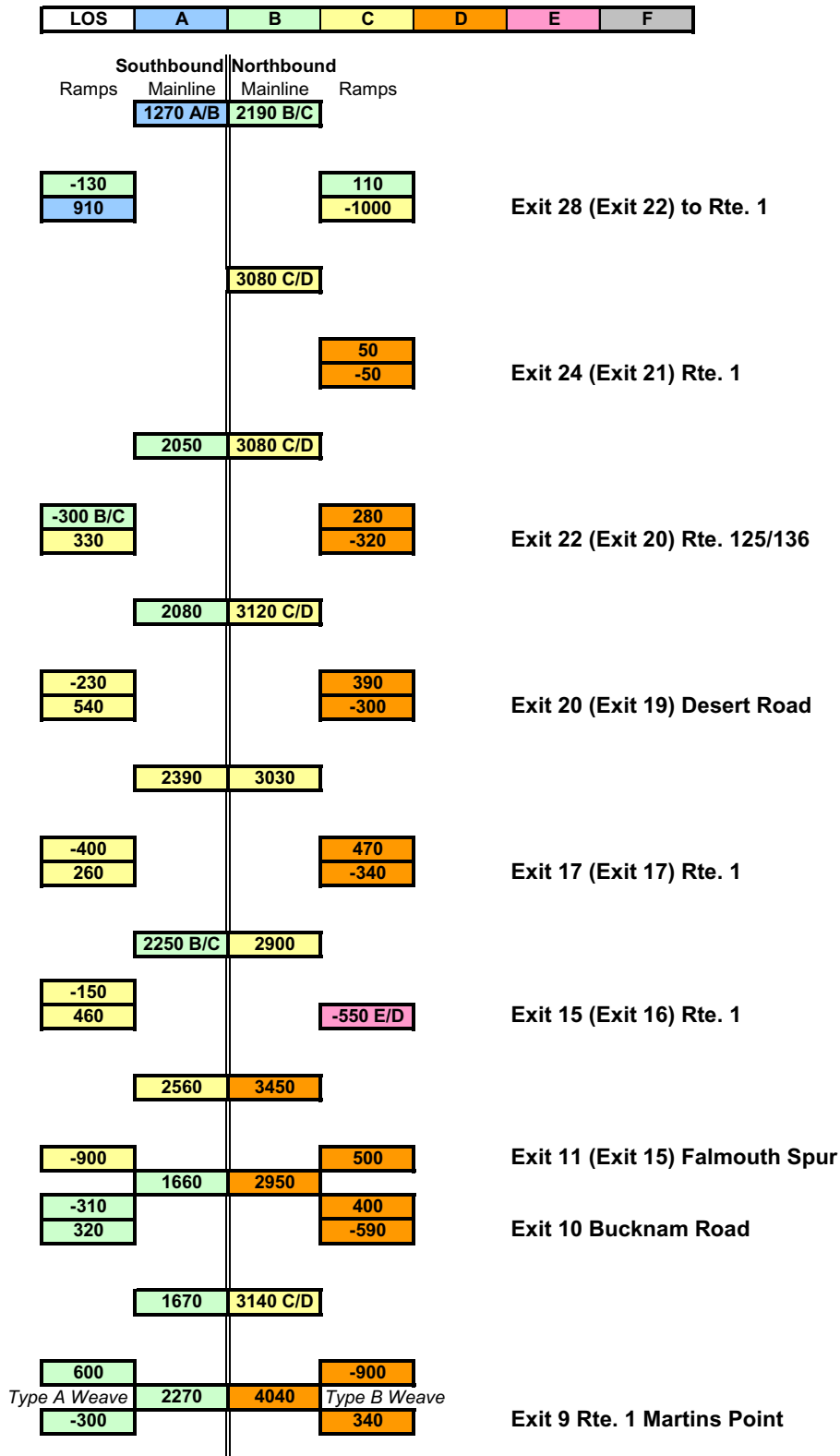

Appendix 4

Year 2025 "No-Build" Network for the PACTS Travel Demand Model

Intercity passenger rail

Code a passenger rail line between Kennebunk (the southern end of the model) and Brunswick (the northern end of the model) with stops in Saco, OOB, the Portland Transportation Center, Bayside, Yarmouth, Freeport and Brunswick. Please note that the PACTS model can simulate the demand for transit service, but that the outputs must subsequently be factored "off-model".

Turnpike Toll Structure

We will assume no change to the current physical toll collection structure or to the toll amounts.

Highway Links (includes some construction done since 2000)

We are not including a six lane Turnpike between Exits 6A and 9. While *Destination Tomorrow* recommends it and the Turnpike Authority is thinking seriously about it, we are not certain that it will happen by 2025. (It will be tested as an alternative in DTx.)

1. I-295 SB auxiliary lane between Exit 3 and Exit 4.
2. Southwest bypass of Gorham Village only. We are not certain that a northerly bypass will happen by 2025. This is based on discussions with Ed Hanscom and Carl Croce.
2. Six lane Turnpike south of Exit 6A
3. Gray Village bypass. Endpoints are approximately McConkey Road (by Northbrook Business Park) and Seagull Drive (by Public Works)
4. Route 26 bypass in New Gloucester. Endpoints are: Southerly - north of Snow Hill but south of Raymond Rd on the west side of the road. Northerly - north of Raymond Road but south of Shaker Woods Road on the west side of the road.
5. I-295 Connector in Portland.
6. Turnpike Exit 7B at the Westbrook Arterial and Rand Road.
7. Widen the Maine Mall Road/Payne Road Bridge over Route 703 to six lanes.
8. Widen Johnson Road and Western Avenue to 4 and 5 lanes.
9. Closure of Gorham Road easterly approach at Western/Gorham intersection.
10. Four lanes on Route 111 in Biddeford from Five Points to the Turnpike. End points are: Turnpike Exit 4 to about 100 yards short of Five Points. (The road is one lane in each direction for the last 100 yards to Five Points.)
11. Extension of Westbrook Street to Jetport Plaza/Western Avenue.

12. Extension of Chestnut Street from Somerset to Marginal Way in Portland.
13. Added lanes on Route 100 near Exit 10 in Falmouth were added in June 2000.
Going north there is a Left, Thru, Right at the intersection of Route 100, Exit 10 and Hannaford Entrance. Treat as a Left and a Thru for purposes of Model. Going south there is a Right/Thru and a Thru. Treat as just a thru for the Model.
14. New on-ramp at I-295 Exit 3, and added lanes on Western Avenue will include:
 - a. Westbrook Street approach from Pape Chevrolet.
 - i. Protected slip ramp starting before slightly before the Exit 3 Southbound Off-ramp and continuing onto Broadway before looping back just before Sokokis to meet mainline.
 - ii. A Left, Left/Thru, Right, and the Slip Ramp for turning movements.
 - iii. Four approach lanes included the slip ramp.
 - b. Westbrook Street approach from Route 1.
 - i. There will now be 3 approach lanes (Left, Thru, Right) instead of 2.

Added Capacity at Intersections

1. Five Points in Biddeford
The current intersection will be split into two intersections: (1) will be a four-way intersection of Route 1, Route 111 and a local street at the current location. Route 1 will be four lanes; Route 111 and the local street will be two lanes, and (2) a T-intersection of Route 1 and West Street. Route 1 will be four lanes and West Street will be a two-way street (currently a one-way) with one lane in each direction.
2. Route 111 at turnpike Exit 4 in Biddeford - Two lanes in each direction.
3. Widened Spring/County in Westbrook - New Geometry: All receiving legs will be two lanes; the approaches will be
County W/O Spring - left, two thru, right
County E/O Spring - left, two thru, right
Spring S/O County - left, thru, thru-right
Spring N/O County - two left, thru, thru-right
4. Widened Main Street at Spur in 2003 in South Portland. Heading north on Main St from Scarborough there are two lefts onto the Spur and a thru. There are two northbound lanes after the Spur. Heading South there is a dedicated right onto Spur, two through and a dedicated left into Merry Manor. There are two southbound lanes after the Spur.
5. Widened Morrill's Corner in 2003 (Forest/Allen intersection only) as follows:
 - One left-turn lane on each approach
 - Two through-lanes on each Forest Avenue approach
 - A northbound through-lane from Forest to Allen
 - A right-turn lane and a through/left from Allen to Forest
6. Widen Allen/Washington in Portland -
 - Washington Ave approach from in town -- left, thru, thru-right ... receiving -- two lanes for 300 feet
 - Allen Ave approach from Morrill's -- two lefts, thru-right... receiving -- one lane (same as current)
 - Washington Ave approach from Falmouth -- left, two through, right ... receiving -- two lanes (same as current)

7. Allen Ave approach from Falmouth -- left, thru-right (same as current) ... receiving -- one lane (same as current)
8. Reconfigured Forest Avenue interchange - Add a second lane to NB off-ramp for right turns and signalize that intersection.
9. Reconfigure Marginal/Forest intersection - Allow lefts from Forest (coming off the interstate) onto Marginal Way.
10. Reconfigure Forest/Kennebec intersection - Delete Kennebec Street between Forest Ave and Brattle (the one-way section)
11. Reconfigure Franklin Arterial/Marginal Way - (1) Delete Marginal Way between Franklin Arterial and Diamond Street, (2) Turn-on Diamond Street between Fox and Marginal, (3) have two left-turn lanes from outbound Franklin onto Marginal, add a third outbound thru-lane on Franklin, (4) have two left-turns from Marginal onto 295 and a right-turn onto Franklin
12. Reconfigure Franklin Arterial/Fox/Somerset - (1) add a third lane both inbound and outbound on Franklin Arterial, have both inbound and outbound rights from Franklin, have a left from Franklin onto Somerset and two lefts from Franklin onto Fox (2) have two lefts, a right and a thru from Somerset onto Franklin, (3) have separate right, left and thru lanes on Fox.

Bus Service

Tom Reinauer [of SMRPC], Steve Linnell and David Willauer [both of GPCOG] have advised on the addition of the following additions to the region's bus services that can be expected to be in operation in 2025. Please note that the PACTS model can simulate the demand for transit service, but that the outputs must subsequently be factored "off-model".

Increase BSOOB Tri-Town service frequency from 60 minutes to 30 minutes.

ShuttleBus - No changes.

New Service from Exit 4 area of Rt 111 (or possibly downtown Biddeford) west to Sanford with 30-minute frequency.

New service from Exit 4 area of Rt 111 (or possibly downtown Biddeford) south to Kennebunk via Rt 1 with 30-minute frequency.

Saco to BIW via 95 & 295 (#buses, ridership and time uncertain)

Biddeford to PNSY via 95 (2 buses, ridership and time uncertain)

Mermaid from Portland to Spencer Press in Wells via 95 (#buses, ridership and time uncertain)

METRO - Add Route 7 to Falmouth Route 1 (Bucknam Rd. to Legion to Depot back to Route 1) from the Pulse, at 30 minute headways, 6:00 AM to 9:00 PM six days a week.

Freeport - Add Route 1 service from Hotels to the south (Old County Road) to North Maine Street (Pleasant Street) at 30 minute headways, end of June to first of January, 8:00 AM to 9:00 PM, seven days a week.

SPBS - No changes.

RTP - No changes.

Vanpools

Between	#Vans	#Riders
Lewiston Portland	2	24
Brunswick Portland	2	24
Portland Augusta	2	24
Lakes Region to Portland	1	12
Total	7	84

Appendix 5

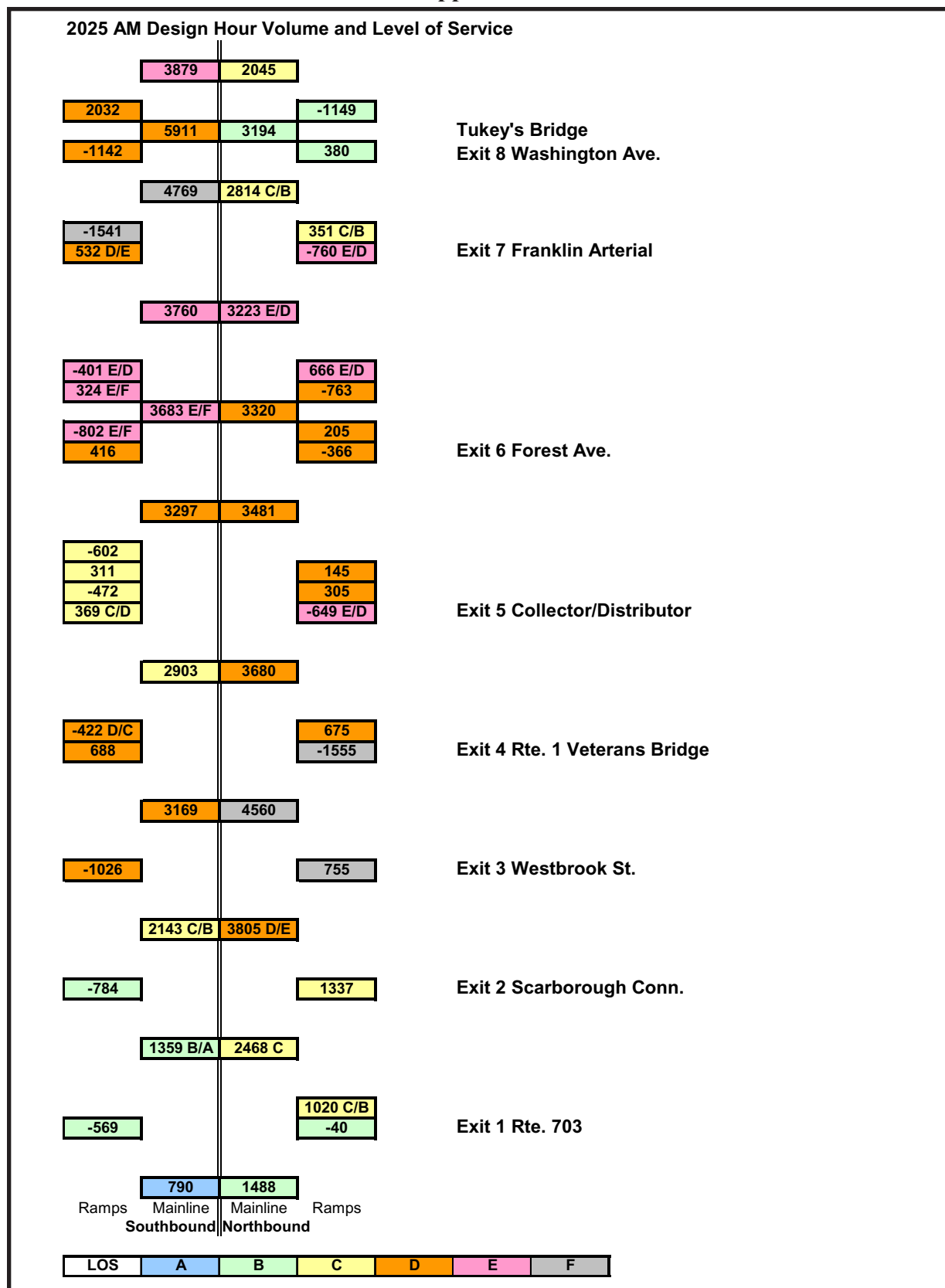

2025 AM Design Hour Volume and Level of Service

LOS	A	B	C	D	E	F
-----	---	---	---	---	---	---

Southbound		Northbound		
Ramps	Mainline	Mainline	Ramps	
	1863	1246		
-196			120	Exit 28 (Exit 22) to Rte. 1
1242			-788	
		1914		
			60 C/B	Exit 24 (Exit 21) Rte. 1
			-105 C/B	
	2909	1959		
-377 C/D			161 B/C	Exit 22 (Exit 20) Rte. 125/136
703			-123 B/C	
	3235	1921		
-506			197 B/C	Exit 20 (Exit 19) Desert Road
269			-352	
	2998	2076		
-402			583	Exit 17 (Exit 17) Rte. 1
517			-216	
	3113 C/D	1709		
-201				Exit 15 (Exit 16) Rte. 1
791			-504	
	3703	2213 B/C		
-734			518	Exit 11 (Exit 15) Falmouth Spur
	2969	1695		
-414			297	Exit 10 Bucknam Road
848			-308	
	3403	1706		
825			-616	Exit 9 Rte. 1 Martins Point
	4228	2322		
-349			277	

Appendix 6

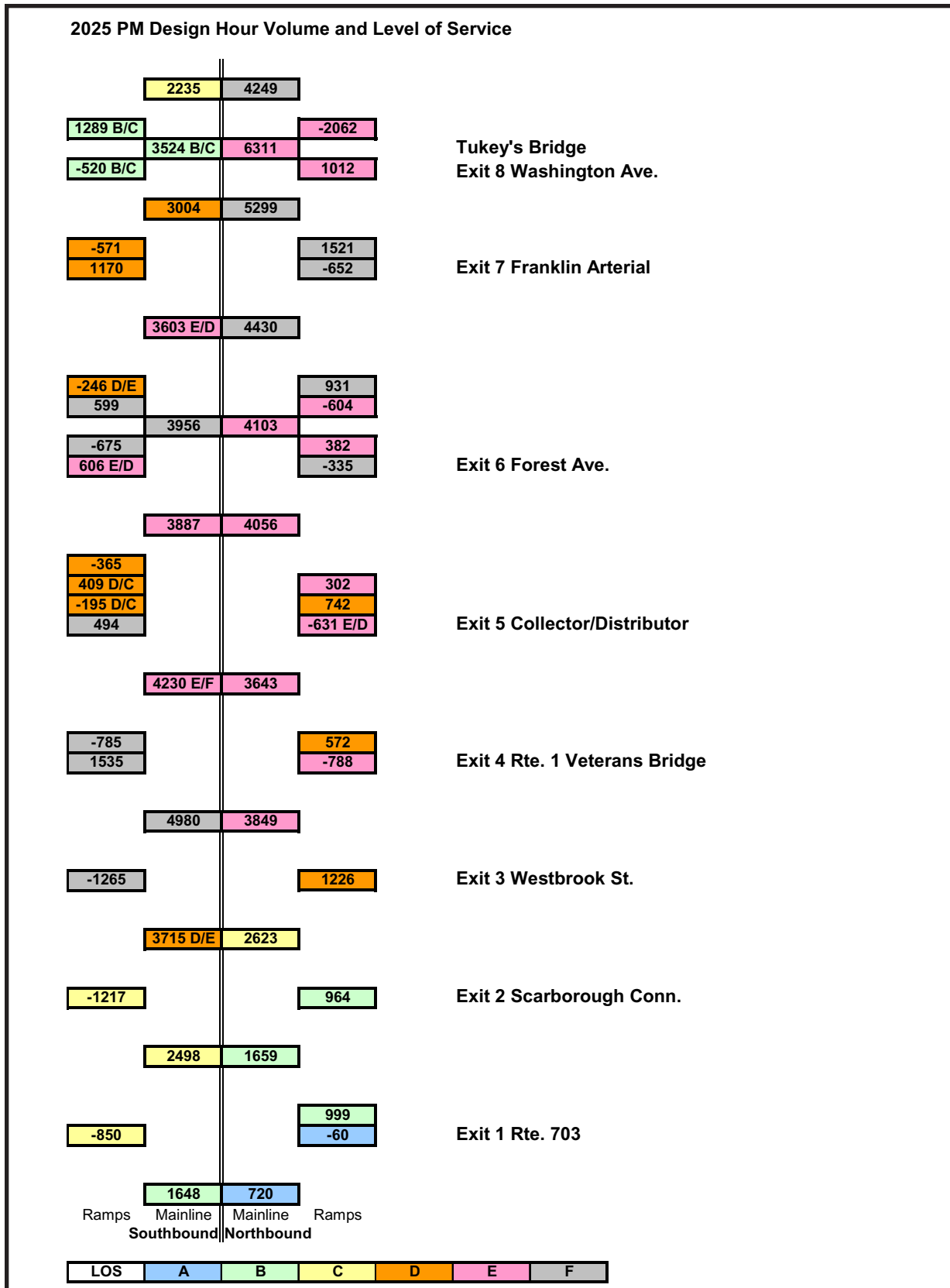

2025 PM Design Hour Volume and Level of Service

LOS	A	B	C	D	E	F
-----	---	---	---	---	---	---

Southbound		Northbound		
Ramps	Mainline	Mainline	Ramps	
	1646	2713		
-180			145	Exit 28 (Exit 22) to Rte. 1
1088			-1236	
		3804 D/E		
			61	Exit 24 (Exit 21) Rte. 1
			-66	
	2554	3809 D/E		
-411			407 E/D	Exit 22 (Exit 20) Rte. 125/136
428			-363	
	2571	3765		
-327			611 E/D	Exit 20 (Exit 19) Desert Road
632 D/C			-329 D/E	
	2876	3483		
-533			593	Exit 17 (Exit 17) Rte. 1
326			-402	
	2669	3292		
-240 C/D			-591	Exit 15 (Exit 16) Rte. 1
524				
	2953	3883		
-1078			664	Exit 11 (Exit 15) Falmouth Spur
	1875	3219		
-367 B/C			454	Exit 10 Bucknam Road
378			-808 E/D	
	1886	3573		
666			-1035	Exit 9 Rte. 1 Martins Point
	2552	4608		
-317			359	

Appendix 7

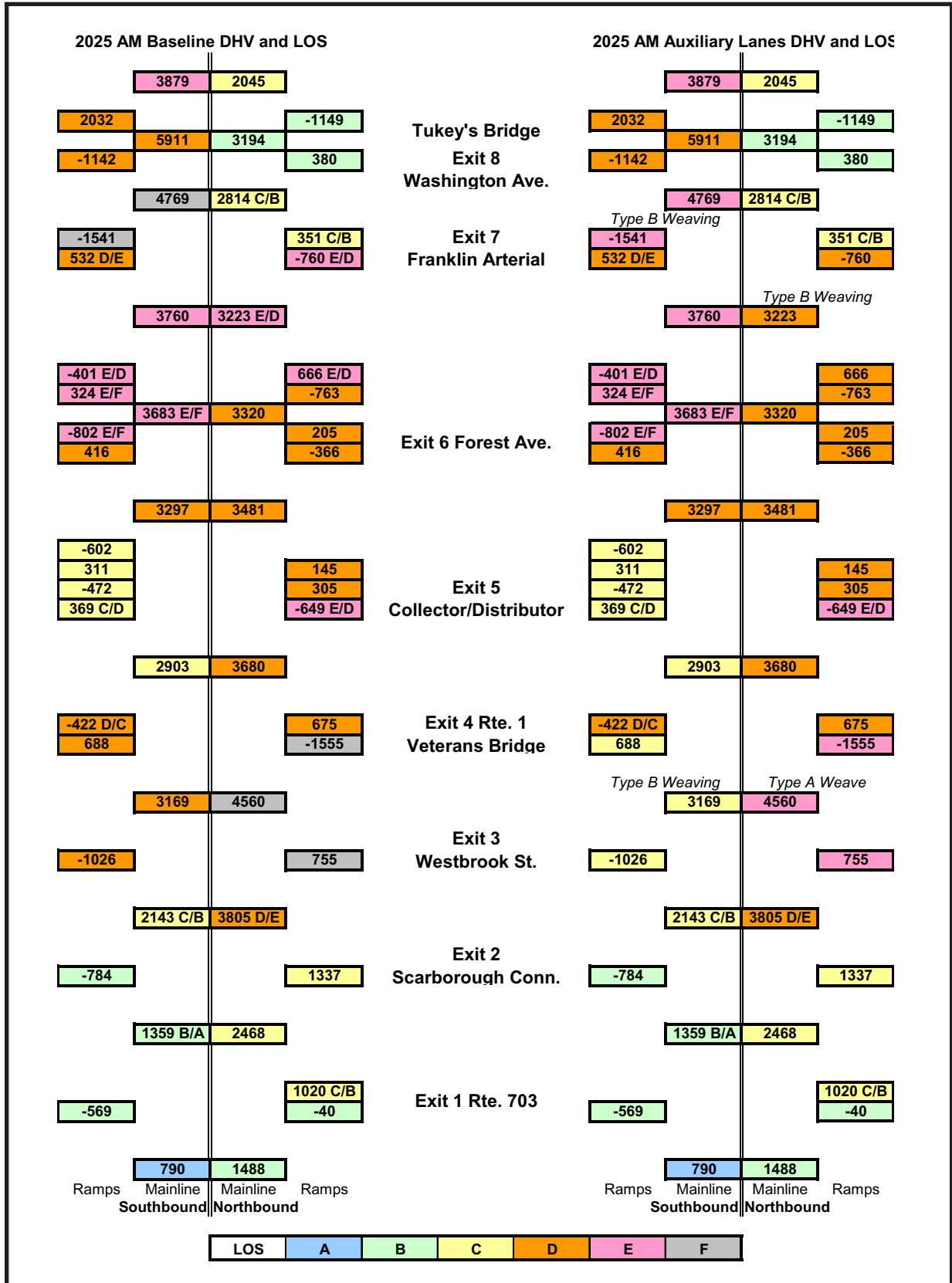

LOS	A	B	C	D	E	F
-----	---	---	---	---	---	---

2025 AM Baseline DHV and LOS

2025 AM Auxiliary Lanes DHV and LOS

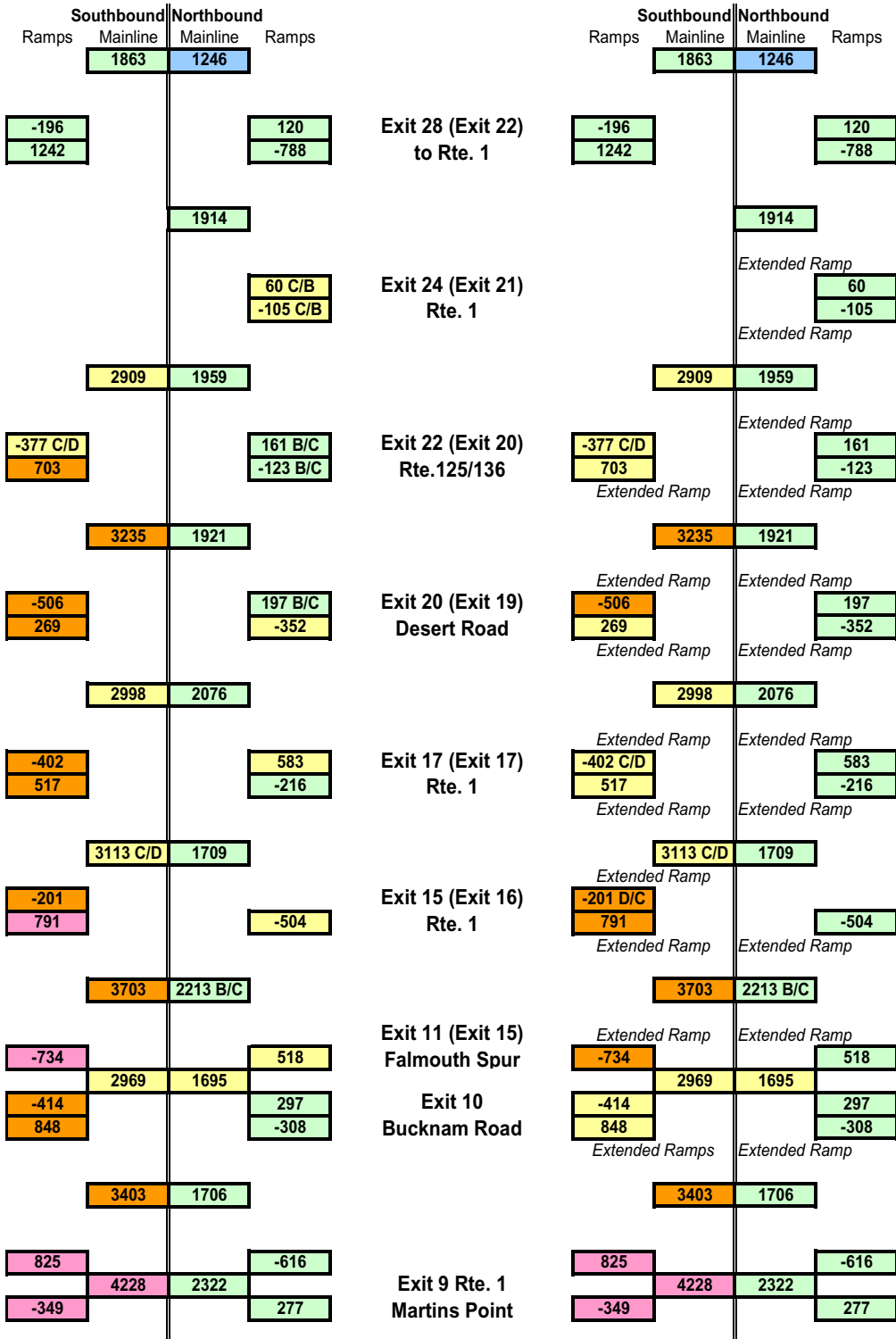

Appendix 8

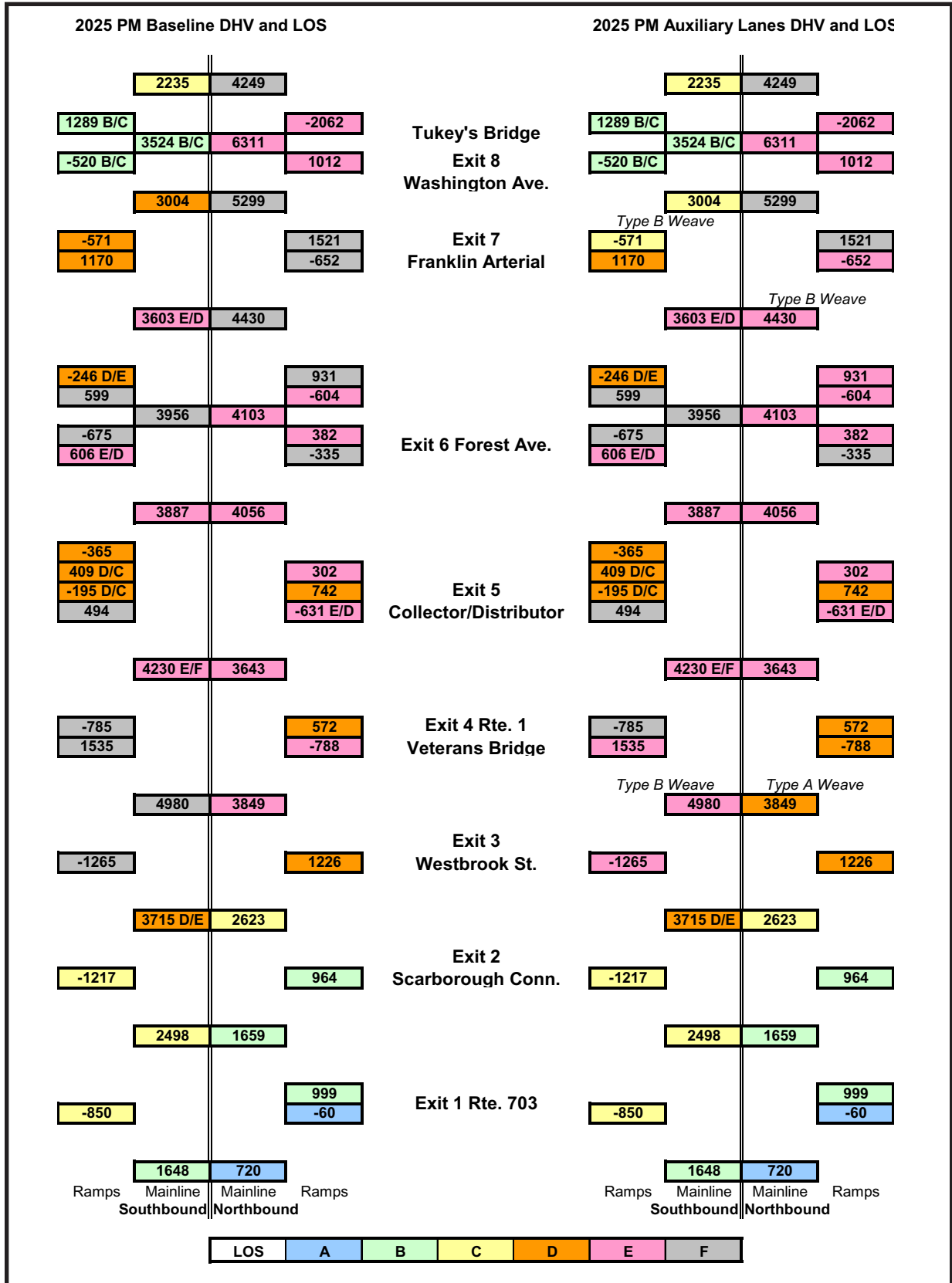

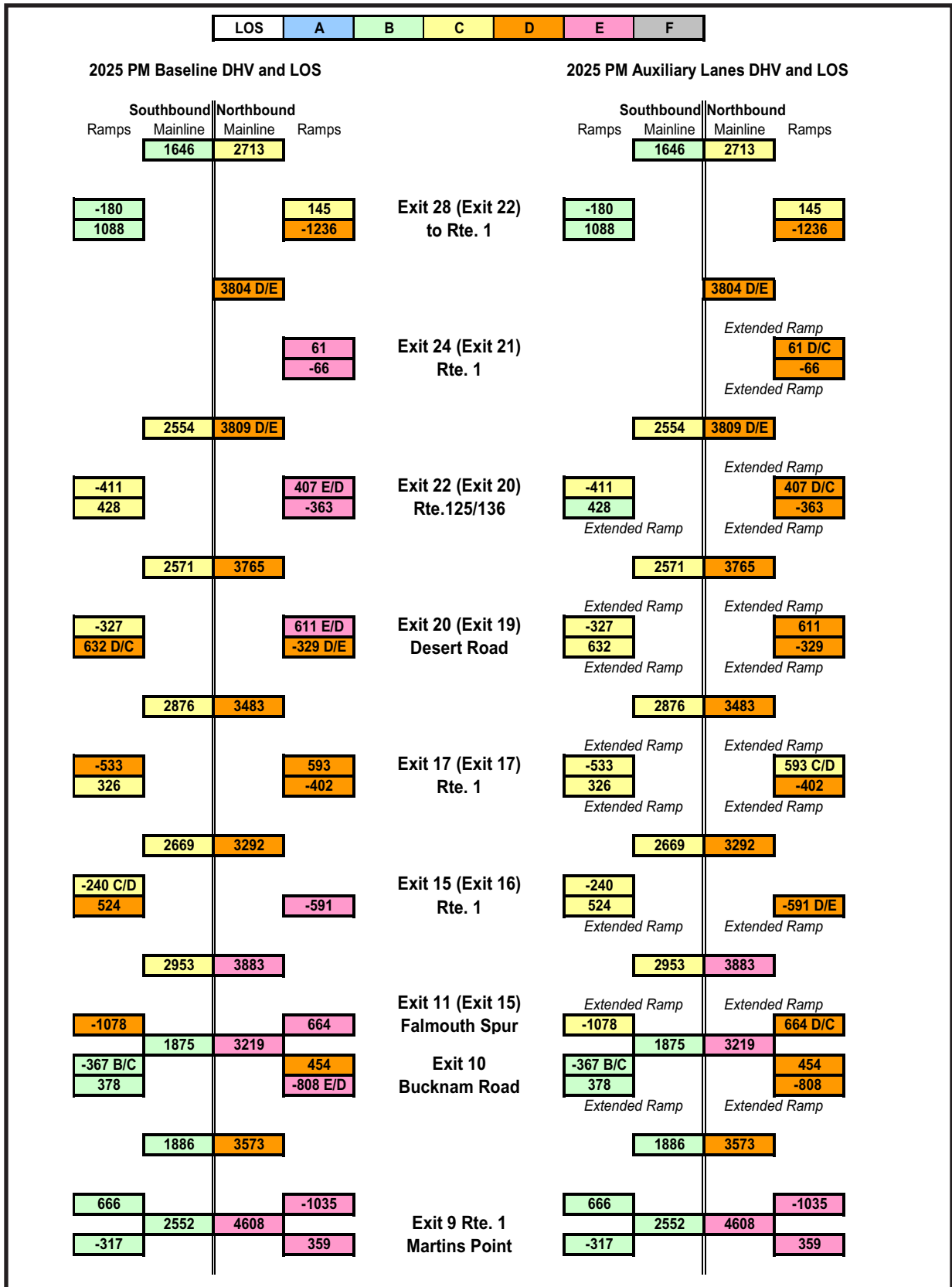

Appendix 9

1. Full Cloverleaf with Collector-Distributor



2. Partial Cloverleaf "A"

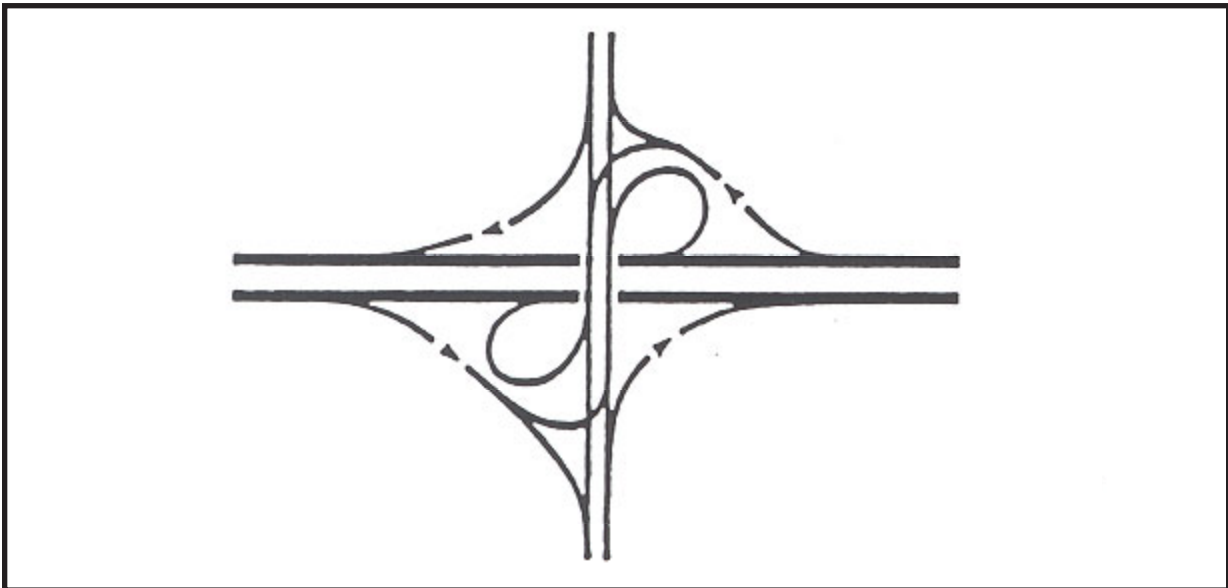

3. Partial Cloverleaf "B"

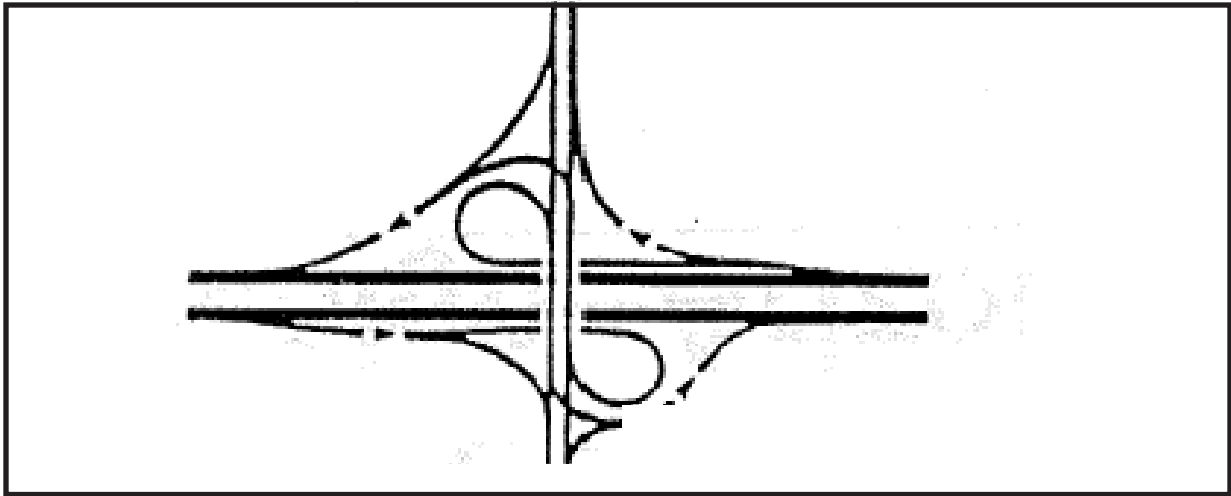

4. Diamond Interchange

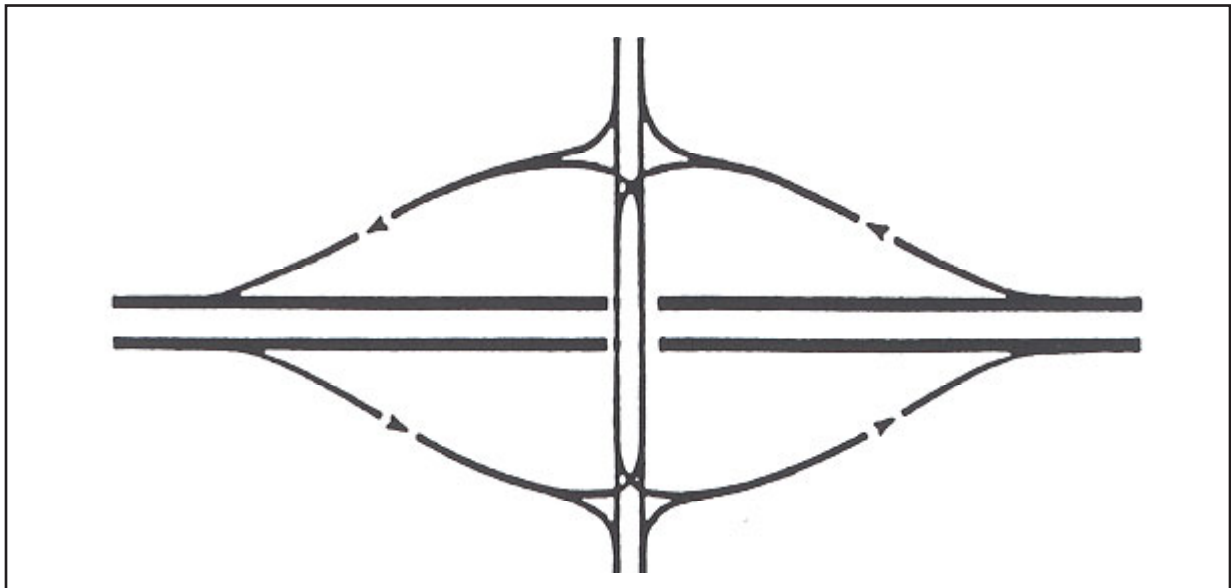

5. Single Point Diamond Interchange

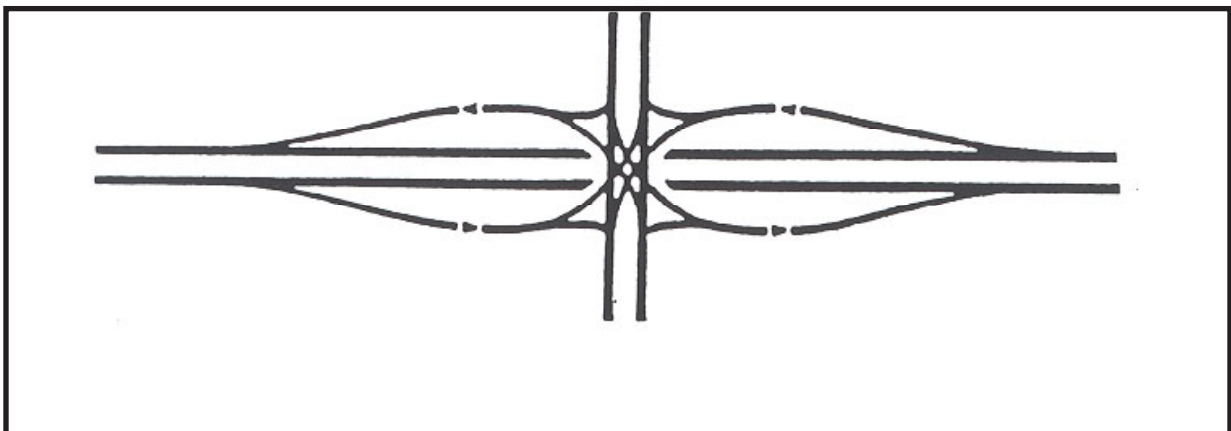

Appendix 10

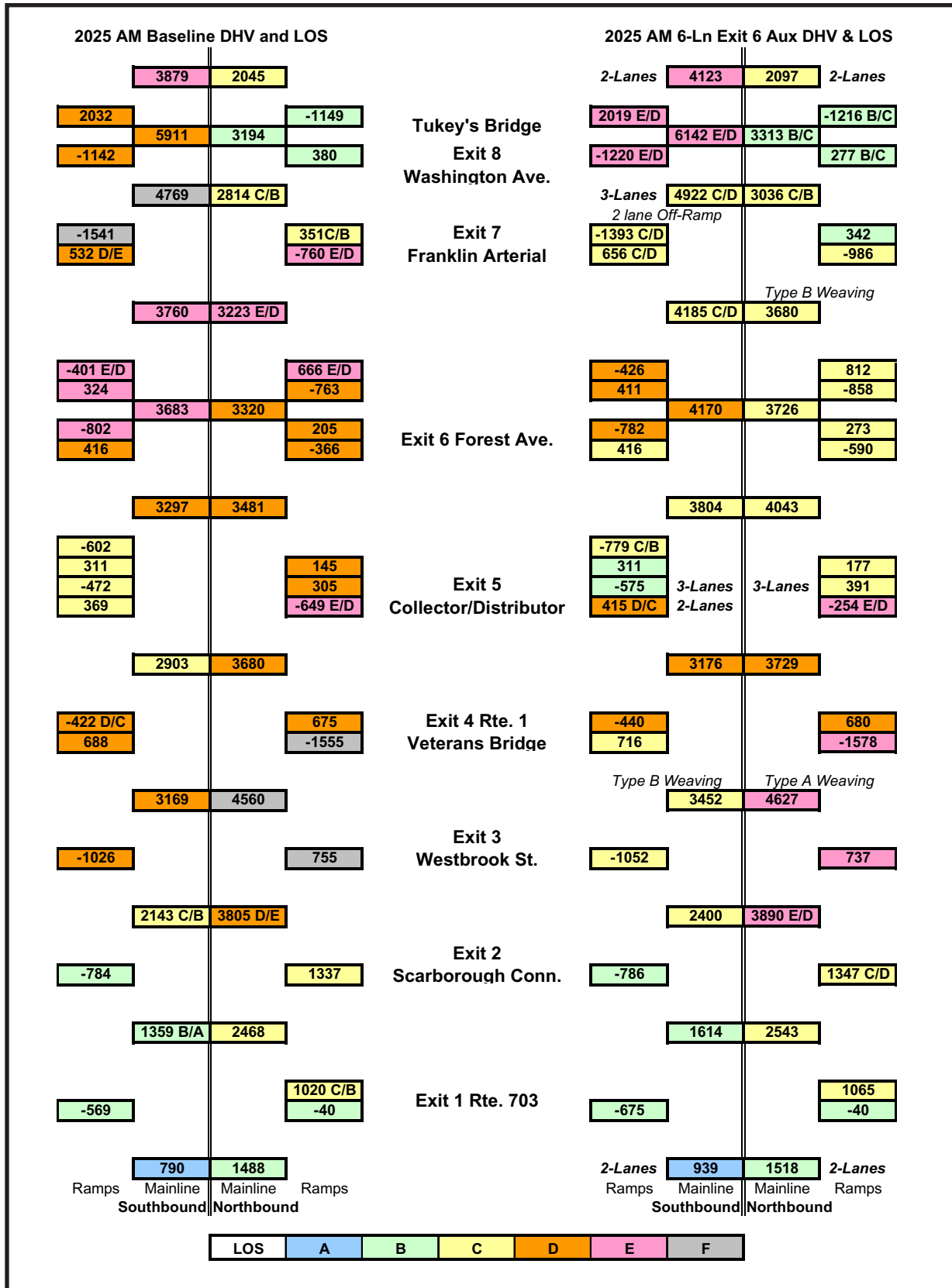

LOS	A	B	C	D	E	F
-----	---	---	---	---	---	---

2025 AM Baseline DHV and LOS

2025 AM 6-Ln Exit 6 Aux DHV & LOS

Southbound		Northbound			Southbound		Northbound	
Ramps	Mainline	Mainline	Ramps		Ramps	Mainline	Mainline	Ramps
	1863	1246			1863	1246		
-196			120	Exit 28 (Exit 22) to Rte. 1	-202			120
1242			-788		1255			-788
		1914					1914	
			60 C/B	Exit 24 (Exit 21) Rte. 1			Extended Ramp	60
			-105 C/B				Extended Ramp	-105
	2909	1959			2916	1959		
-377 C/D			161 B/C	Exit 22 (Exit 20) Rte.125/136	-375 C/D		Extended Ramp	161
703			-123 B/C		709		Extended Ramp	-125
	3235 D/C	1921			3250 D/C	1923		
			197 B/C	Exit 20 (Exit 19) Desert Road	Extended Ramp		Extended Ramp	191
-506			-352		-505		Extended Ramp	-346 B/C
269					251		Extended Ramp	
	2998	2076			2996	2078		
			583	Exit 17 (Exit 17) Rte. 1	Extended Ramp		Extended Ramp	592
-402			-216		-399 C/D		Extended Ramp	-213
517					516		Extended Ramp	
	3113 C/D	1709			3113 C/D	1699		
				Exit 15 (Exit 16) Rte. 1	Extended Ramp		Extended Ramp	
-201			-504		-201 D/C		Extended Ramp	-511
791 E/D					801 D/C		Extended Ramp	
	3703	2213 B/C			3713	2210 B/C		
			518	Exit 11 (Exit 15) Falmouth Spur	Extended Ramp		Extended Ramp	509
-734					-599		Extended Ramp	
	2969	1695	297	Exit 10 Bucknam Road	3114 C/D	1701	Extended Ramp	292
-414			-308		-413 C/D		Extended Ramp	-320
848					841		Extended Ramps	
	3403	1706			3542	1729		
825			-616	Exit 9 Rte. 1 Martins Point	875			-631
	4228	2322				4417	2360	
-349			277		-294			263

Appendix 11

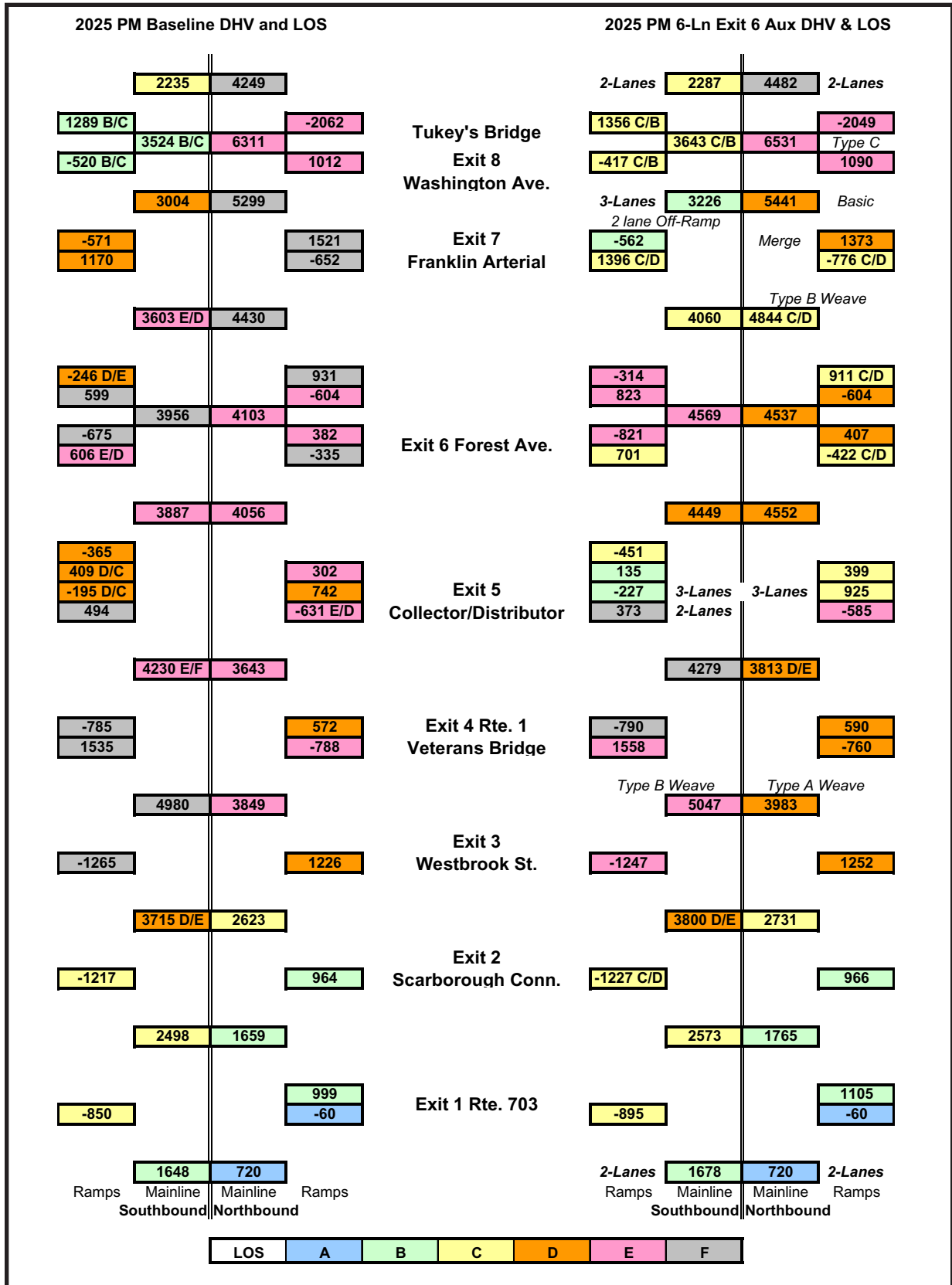

LOS	A	B	C	D	E	F
-----	---	---	---	---	---	---

2025 PM Baseline DHV and LOS

2025 PM 6-Ln Exit 6 Aux DHV & LOS

Southbound		Northbound			Southbound		Northbound	
Ramps	Mainline	Mainline	Ramps		Ramps	Mainline	Mainline	Ramps
	1646	2713			1646	2702		
-180			145	Exit 28 (Exit 22) to Rte. 1	-180			145
1088			-1236		1088			-1236
		3804 D/E					3793 D/E	
			61	Exit 24 (Exit 21) Rte. 1			67 D/C	
			-66				-79	
	2554	3809 D/E			2554	3805 D/E		
-411			407 E/D	Exit 22 (Exit 20) Rte.125/136	-411		405 C/D	
428			-363		430		-369	
					Extended Ramp		Extended Ramp	
	2571	3765			2573	3769		
-327			611 E/D	Exit 20 (Exit 19) Desert Road	Extended Ramp		Extended Ramp	
632 D/C			-329 D/E		-321		610	
					626		-311	
					Extended Ramp		Extended Ramp	
	2876	3483			2878	3470		
-533			593	Exit 17 (Exit 17) Rte. 1	Extended Ramp		Extended Ramp	
326			-402		-531		590 C/D	
					323		-401	
					Extended Ramp		Extended Ramp	
	2669	3292			2670	3281		
-240 C/D			-591	Exit 15 (Exit 16) Rte. 1	Extended Ramp			
524					-251		-601 D/E	
					531			
					Extended Ramp		Extended Ramp	
	2953	3883			2950	3882 E/D		
-1078			664	Exit 11 (Exit 15) Falmouth Spur	Extended Ramp		Extended Ramp	
	1875	3219	454		-1069		529 D/C	
-367 B/C			-808 E/D	Exit 10 Bucknam Road	1881	3353	453	
378					-362		-801	
					390			
					Extended Ramps		Extended Ramp	
	1886	3573			1909	3701		
666			-1035	Exit 9 Rte. 1 Martins Point			Type B Weave	
	2552	4608	359		681		-1085	
-317					-303	2590	4786	304

Appendix 12

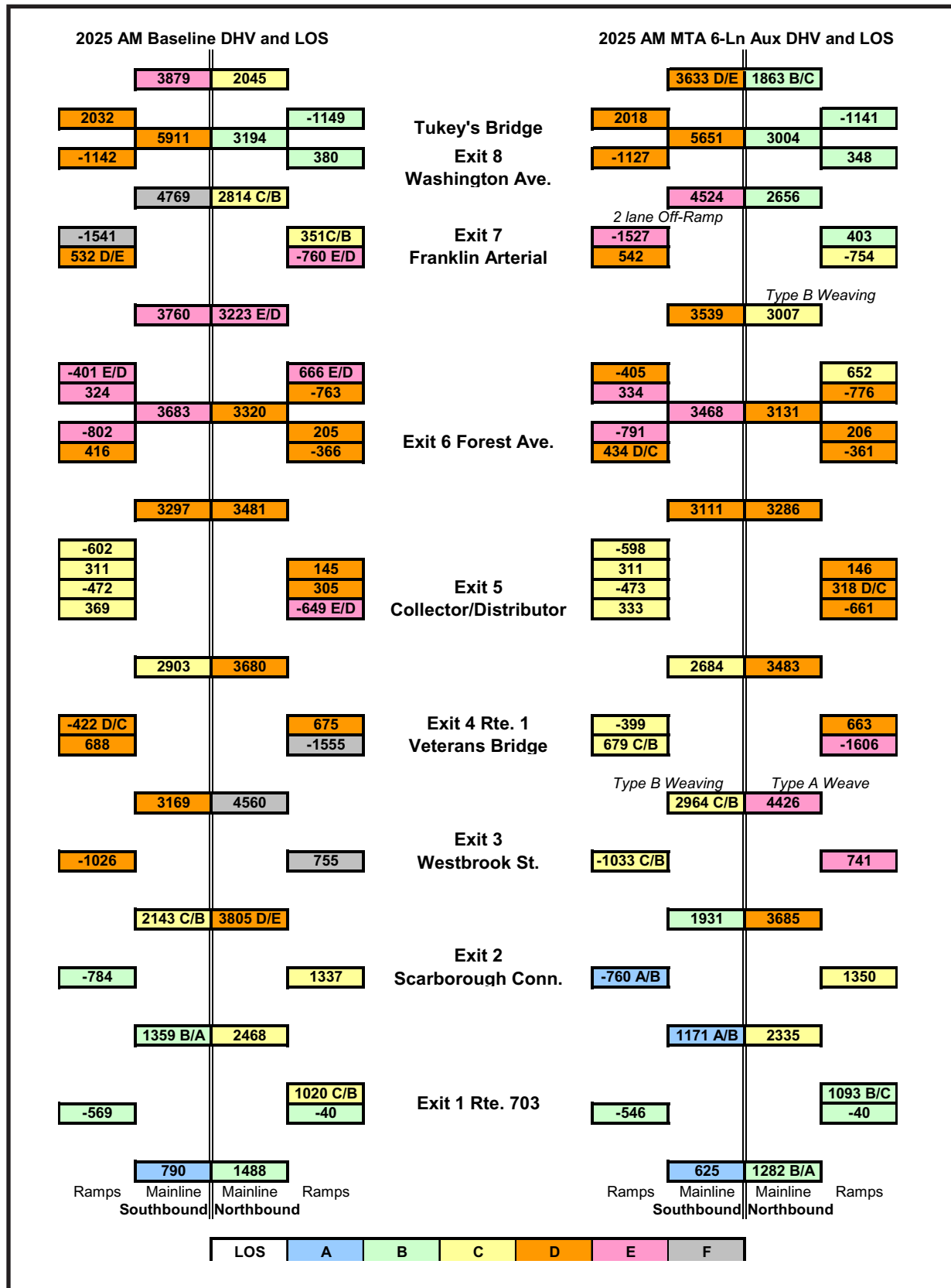

LOS	A	B	C	D	E	F
-----	---	---	---	---	---	---

2025 AM Baseline DHV and LOS

2025 AM MTA 6-Ln Aux DHV and LOS

Southbound		Northbound			Southbound		Northbound	
Ramps	Mainline	Mainline	Ramps		Ramps	Mainline	Mainline	Ramps
	1863	1246			1863	1246		
-196			120	Exit 28 (Exit 22) to Rte. 1	-207			120
1242			-788		1211			-788
		1914					1914	
			60 C/B	Exit 24 (Exit 21) Rte. 1				60
			-105 C/B					-105
	2909	1959			2867	1959		
-377 C/D			161 B/C	Exit 22 (Exit 20) Rte.125/136	-370 C/D			161
703			-123 B/C		738			-130
	3235 D/C	1921			3235 D/C	1928		
-506			197 B/C	Exit 20 (Exit 19) Desert Road	-502			193
269			-352		177			-343 B/C
	2998	2076			2910	2078		
-402			583	Exit 17 (Exit 17) Rte. 1	-398			588
517			-216		519			-216
	3113 C/D	1709			3031	1706		
-201				Exit 15 (Exit 16) Rte. 1	-201 C/D			-510
791 E/D			-504		717			
	3703	2213 B/C			3547	2216 B/C		
-734			518	Exit 11 (Exit 15) Falmouth Spur	-769			668
	2969	1695			2778	1548		
-414			297	Exit 10 Bucknam Road	-408			300
848			-308		800			-287
	3403	1706			3170 D/C	1535		
825			-616	Exit 9 Rte. 1 Martins Point	807 D/E			-610
-349	4228	2322	277		-344 D/E	3977 D/E	2145	282

Appendix 13

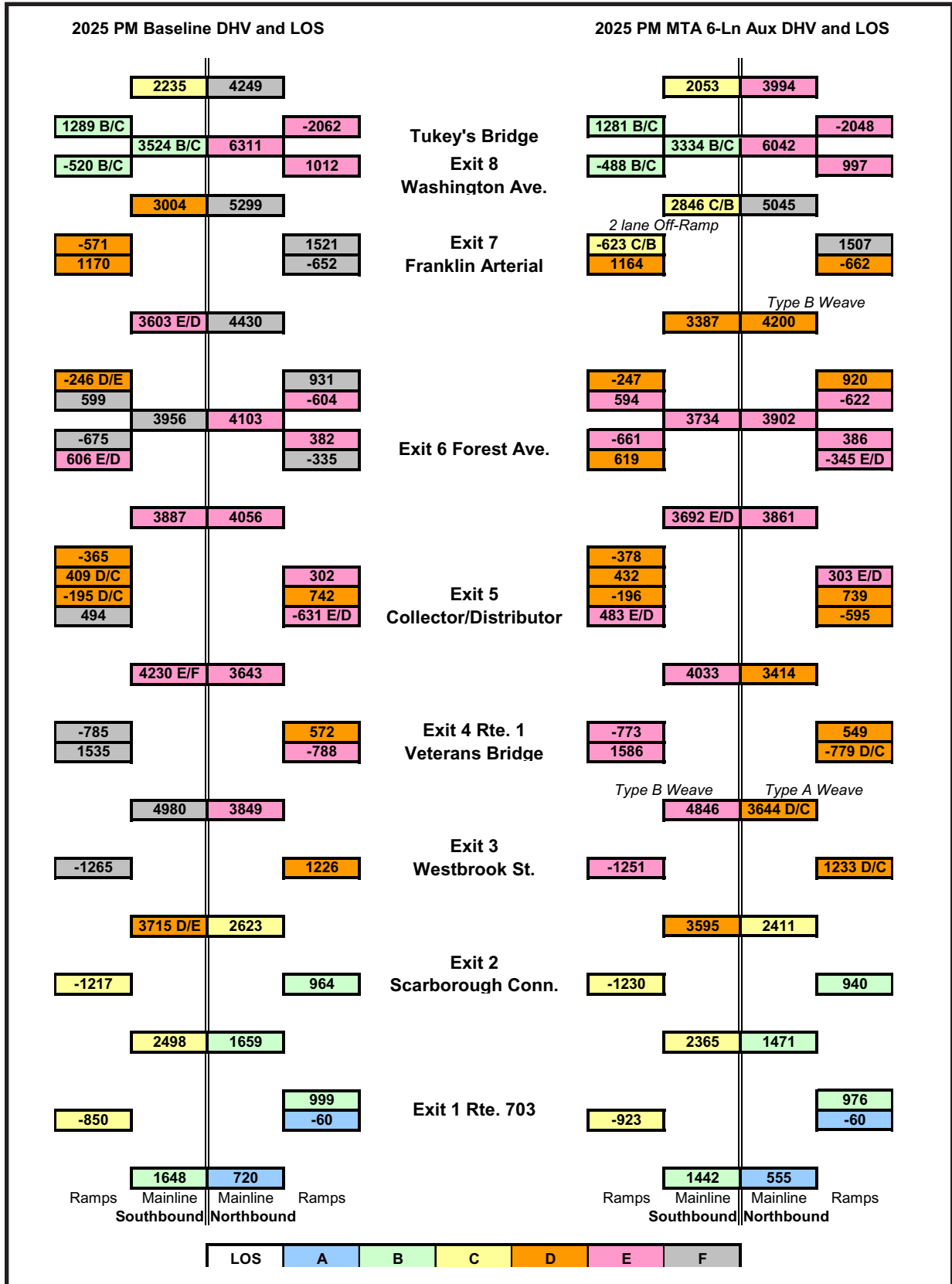

LOS	A	B	C	D	E	F
-----	---	---	---	---	---	---

2025 PM Baseline DHV and LOS

2025 PM MTA 6-Ln Aux DHV and LOS

Southbound		Northbound			Southbound		Northbound	
Ramps	Mainline	Mainline	Ramps		Ramps	Mainline	Mainline	Ramps
	1646	2713			1646	2704		
-180			145	Exit 28 (Exit 22) to Rte. 1	-180			145
1088			-1236		1088			-1236
		3804 D/E					3795 D/E	
			61	Exit 24 (Exit 21) Rte. 1			Extended Ramp	72 D/C
			-66				Extended Ramp	-35
	2554	3809 D/E			2554	3758		
-411			407 E/D	Exit 22 (Exit 20) Rte.125/136	-411		Extended Ramp	400 C/D
428			-363		435		Extended Ramp	-398
	2571	3765			2578	3756		
-327			611 E/D	Exit 20 (Exit 19) Desert Road	Extended Ramp		Extended Ramp	607
632 D/C			-329 D/E		-323		Extended Ramp	-237
					623		Extended Ramp	
	2876	3483			2878	3386		
-533			593	Exit 17 (Exit 17) Rte. 1	Extended Ramp		Extended Ramp	589
326			-402		-528		Extended Ramp	-404 D/C
					326		Extended Ramp	
	2669	3292			2676	3201 D/C		
-240 C/D			-591	Exit 15 (Exit 16) Rte. 1	Extended Ramp		Extended Ramp	-517
524					-250		Extended Ramp	
					530			
	2953	3883			2956	3718		
-1078			664	Exit 11 (Exit 15) Falmouth Spur	Extended Ramp		Extended Ramp	699
					-1228		Extended Ramp	
	1875	3219	454	Exit 10 Bucknam Road		1728	3019	448
-367 B/C			-808 E/D		-370		Extended Ramp	-760
378					357 B/A			
	1886	3573			1715	3331		
666			-1035	Exit 9 Rte. 1	660 B/C			-1017 D/E
						2375 B/C	4348 D/E	
	2552	4608		Martins Point	-322 B/C			354 D/E
-317								

Appendix 14

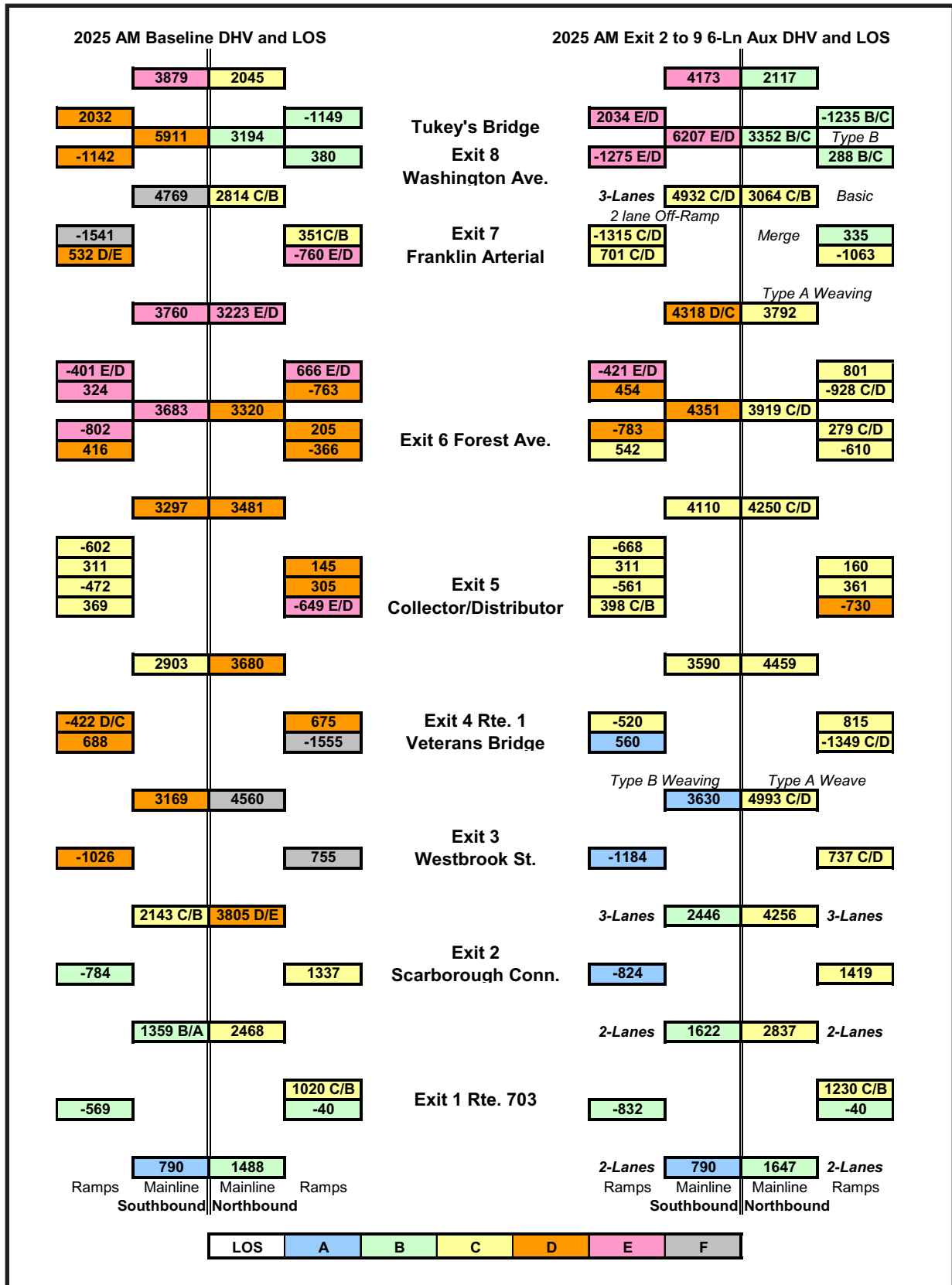

LOS	A	B	C	D	E	F
-----	---	---	---	---	---	---

2025 AM Baseline DHV and LOS

2025 AM Exit 2 to 9 6-Ln Aux DHV and LOS

Southbound		Northbound			Southbound		Northbound	
Ramps	Mainline	Mainline	Ramps		Ramps	Mainline	Mainline	Ramps
	1863	1246			2-Lanes	1863	1246	
-196			120	Exit 28 (Exit 22) to Rte. 1	-195			120
1242			-788		1242			-788
		1914					1914	
			60 C/B	Exit 24 (Exit 21) Rte. 1			Extended Ramp	60
			-105 C/B				Extended Ramp	-105
	2909	1959			2910	1959		
-377 C/D			161 B/C	Exit 22 (Exit 20) Rte.125/136	-385 C/D		Extended Ramp	160
703			-123 B/C		694		Extended Ramp	-105
	3235 D/C	1921			Extended Ramp	3219 D/C	1904	
-506			197 B/C	Exit 20 (Exit 19) Desert Road	Extended Ramp	Extended Ramp	Extended Ramp	199
269			-352		-502		Extended Ramp	-366
	2998	2076			278		Extended Ramp	
			583	Exit 17 (Exit 17) Rte. 1	Extended Ramp	2995	2071	
-402			-216		-396 C/D		Extended Ramp	582
517					518		Extended Ramp	-221
	3113 C/D	1709		Exit 15 (Exit 16) Rte. 1	Extended Ramp	3117 C/D	1710	
-201			-504		Extended Ramp	Extended Ramp	Extended Ramp	-505
791 E/D					-201 D/C		Extended Ramp	
	3703	2213 B/C		Exit 11 (Exit 15) Falmouth Spur	787 D/C		Extended Ramp	
			518		Extended Ramp	3703	2215 B/C	
-734					Extended Ramp	Extended Ramp	Extended Ramp	505
	2969	1695	297	Exit 10 Bucknam Road	-528	3175 D/C	1710	293
-414			-308		826 C/D		Extended Ramp	-324
848					Extended Ramps	Extended Ramp		
	3403	1706				3581	1741	2-Lanes
							Type C Weave	
825			-616	Exit 9 Rte. 1 Martins Point	880			-635
	4228	2322			-288	4461	2376	259
-349			277					

Appendix 15

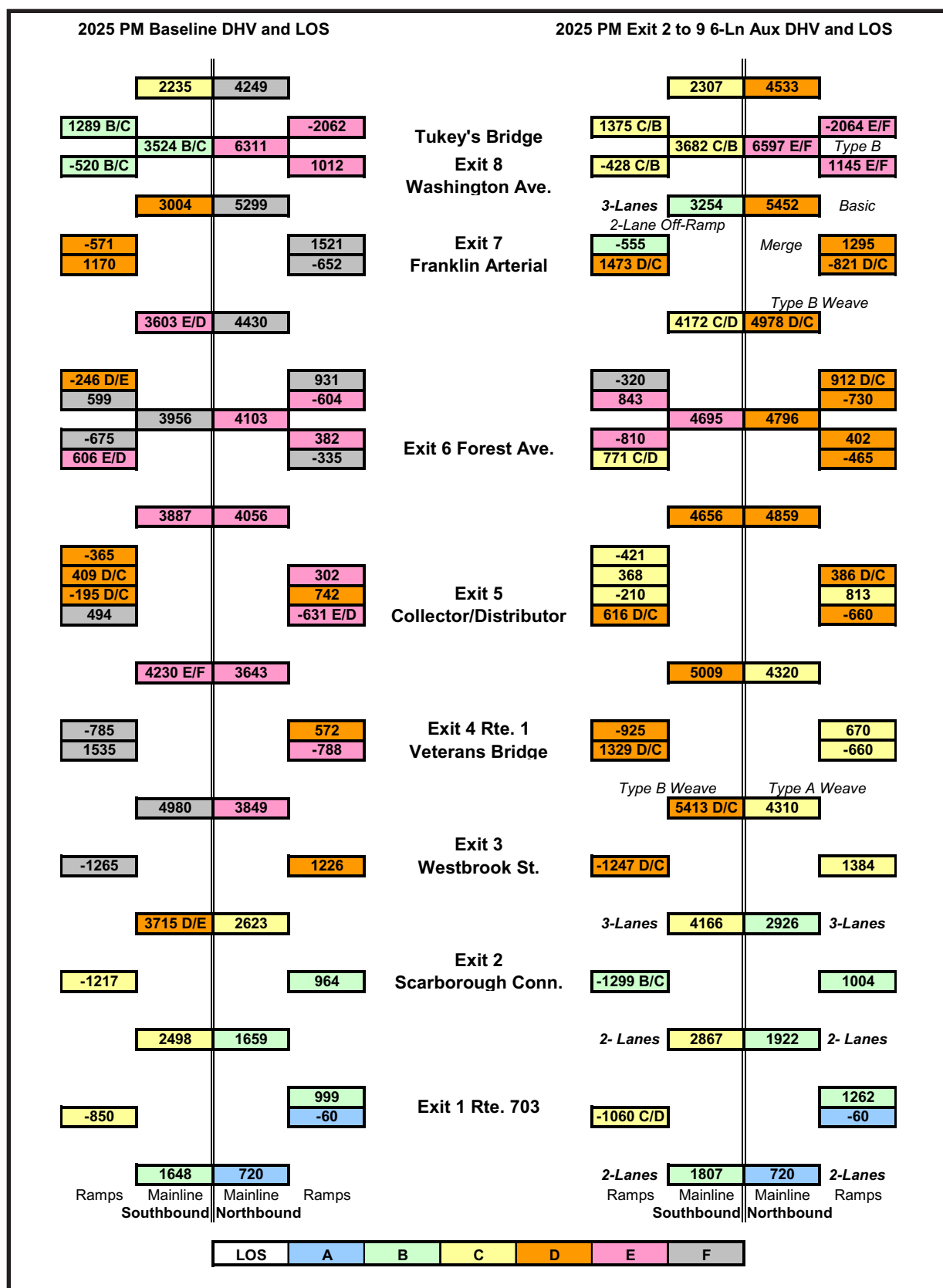

LOS	A	B	C	D	E	F
-----	---	---	---	---	---	---

2025 PM Baseline DHV and LOS

2025 PM Exit 2 to 9 6-Ln Aux DHV and LOS

2025 PM Baseline DHV and LOS				2025 PM Exit 2 to 9 6-Ln Aux DHV and LOS				
Southbound		Northbound			Southbound		Northbound	
Ramps	Mainline	Mainline	Ramps		Ramps	Mainline	Mainline	Ramps
	1646	2713			2-Lanes	1646	2703	
-180			145	Exit 28 (Exit 22) to Rte. 1	-180			145
1088			-1236		1088			-1236
		3804 D/E					3794 D/E	
			61	Exit 24 (Exit 21) Rte. 1			Extended Ramp	60 D/C
			-66				Extended Ramp	-66
	2554	3809 D/E				2554	3800 D/E	
-411			407 E/D	Exit 22 (Exit 20) Rte.125/136	-410		Extended Ramp	415 C/D
428			-363		410		Extended Ramp	-354
					Extended Ramp			
	2571	3765				2554	3739	
-327			611 E/D	Exit 20 (Exit 19) Desert Road	Extended Ramp		Extended Ramp	607
632 D/C			-329 D/E		-329		Extended Ramp	-338
					646		Extended Ramp	
					Extended Ramp			
	2876	3483				2871	3470	
-533			593	Exit 17 (Exit 17) Rte. 1	Extended Ramp		Extended Ramp	587 C/D
326			-402		-521		Extended Ramp	-403
					331		Extended Ramp	
					Extended Ramp			
	2669	3292				2681	3286	
-240 C/D				Exit 15 (Exit 16) Rte. 1	Extended Ramp			
524			-591		-251		Extended Ramp	-587 D/E
					525		Extended Ramp	
					Extended Ramp			
	2953	3883				2955	3873 E/D	
-1078			664	Exit 11 (Exit 15) Falmouth Spur	Extended Ramp		Extended Ramp	458 D/C
	1875	3219			-1065		Extended Ramp	
-367 B/C			454	Exit 10 Bucknam Road	1890	3415	Extended Ramp	460
378			-808 E/D		-363		Extended Ramp	-786
					394		Extended Ramps	
					Extended Ramps			
	1886	3573				1921	3741	2-Lanes
							Type C Weave	
666			-1035	Exit 9 Rte. 1 Martins Point	685		Extended Ramp	-1090 C/D
	2552	4608				2606	4831 C/D	
-317			359		-299		Extended Ramp	298 C/D

Appendix 16

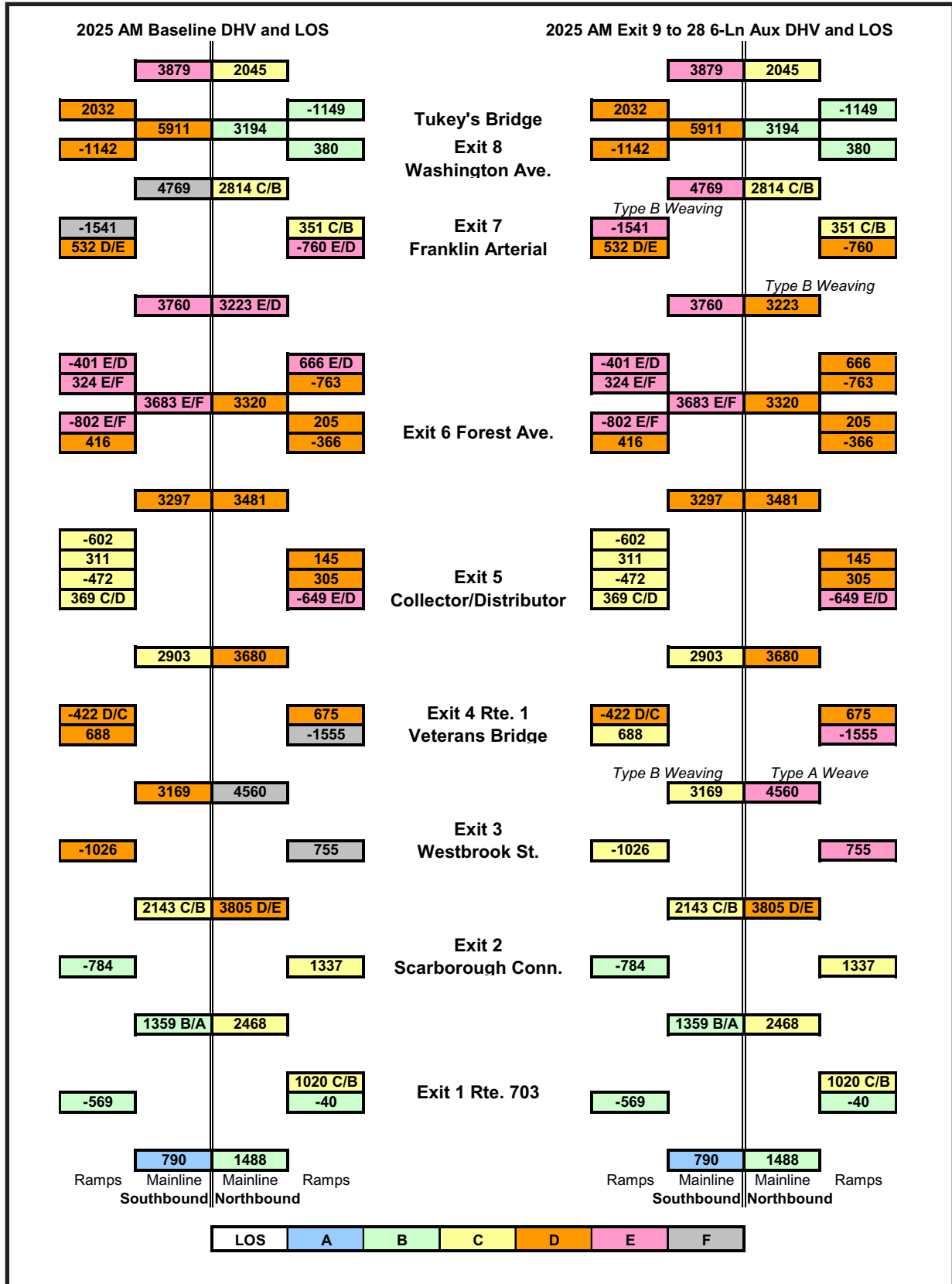

LOS	A	B	C	D	E	F
-----	---	---	---	---	---	---

2025 AM Baseline DHV and LOS

2025 AM Exit 9 to 28 6-Ln Aux DHV and LOS

2025 AM Baseline DHV and LOS				2025 AM Exit 9 to 28 6-Ln Aux DHV and LOS				
Southbound		Northbound			Southbound		Northbound	
Ramps	Mainline	Mainline	Ramps		Ramps	Mainline	Mainline	Ramps
	1863	1246			2-Lanes	1863	1246	2-Lanes
-196			120	Exit 28 (Exit 22) to Rte. 1	-196			120
1242			-788		1242			-788
		1914			3-Lanes		1914 A/B	3-Lanes
			60 C/B	Exit 24 (Exit 21) Rte. 1				60
			-105 C/B					-105 B/A
	2909	1959			3-Lanes	2909	1959 A/B	
-377 C/D			161 B/C	Exit 22 (Exit 20) Rte.125/136	-377 B/C			161
703			-123 B/C		703			-123 B/A
					Extended Ramp			Extended Ramp
	3235	1921			3235	1921 A/B		
-506			197 B/C	Exit 20 (Exit 19) Desert Road	-506 B/C			197 A/B
269			-352		269			-352
					Extended Ramp			Extended Ramp
	2998	2076			2998	2076 A/B		
-402			583	Exit 17 (Exit 17) Rte. 1	-402 B/C			583 B/A
517			-216		517			-216 B/A
					Extended Ramp			Extended Ramp
	3113 C/D	1709			3113	1709		
-201				Exit 15 (Exit 16) Rte. 1	-201			
791			-504		791			-504
					Extended Ramp			Extended Ramp
	3703	2213 B/C			3703	2213 B/A		
-734			518	Exit 11 (Exit 15) Falmouth Spur	-734			518
	2969	1695			2969	1695		
-414			297	Exit 10 Bucknam Road	-414			297
848			-308		848			-308 A/B
					Extended Ramps			Extended Ramp
	3403	1706			3-Lanes	3403 B/C	1706	3-Lanes
825			-616		825			-616
	4228	2322		Exit 9 Rte. 1 Martins Point		4228	2322	
-349			277		-349			277

Appendix 17

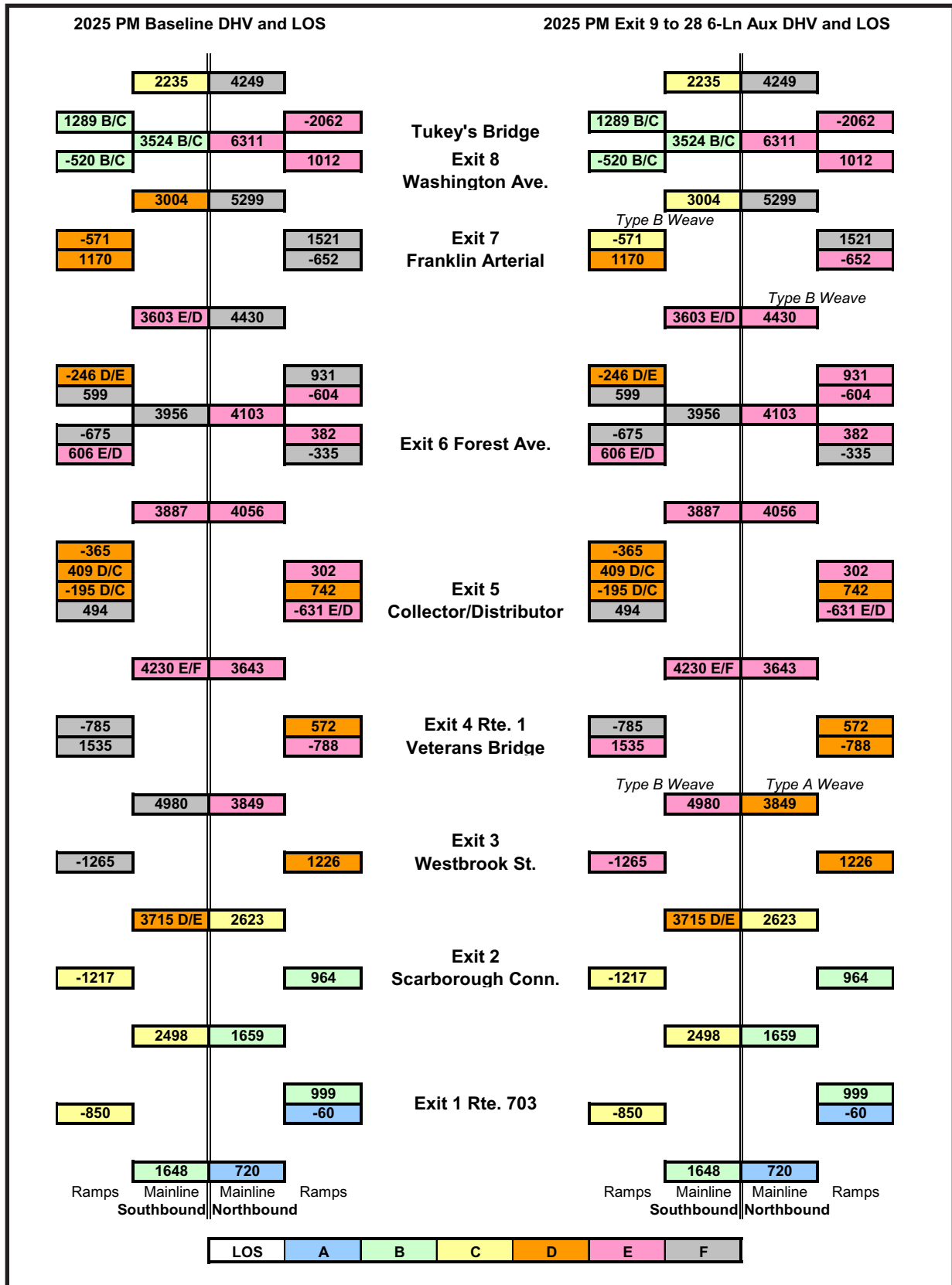

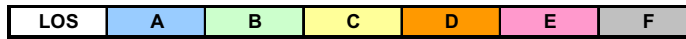

2025 PM Baseline DHV and LOS

2025 PM Exit 9 to 28 6-Ln Aux DHV and LOS

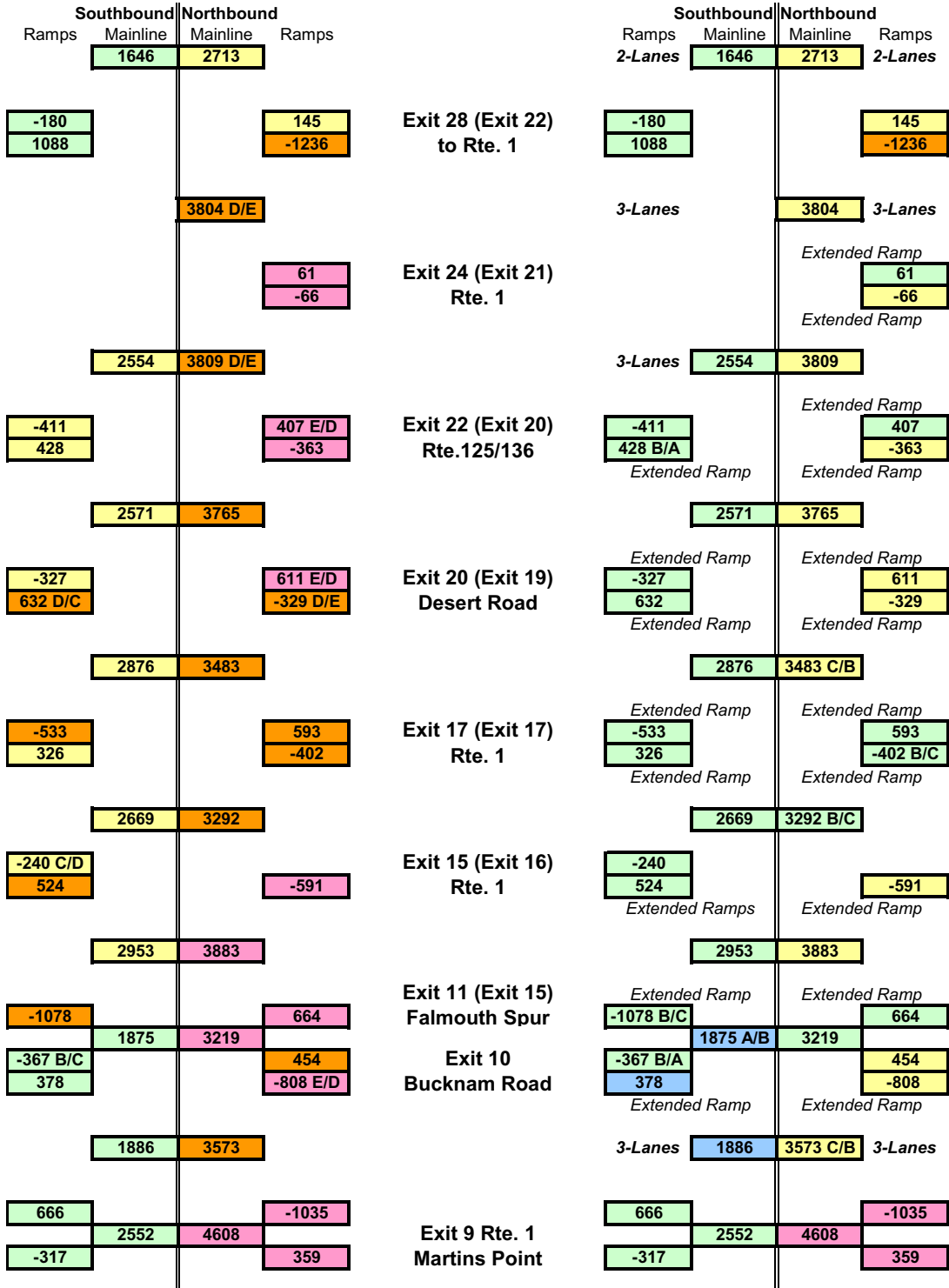

LOS	A	B	C	D	E	F
-----	---	---	---	---	---	---

2025 AM Baseline DHV and LOS

2025 AM Differential Toll Aux DHV and LOS

Southbound		Northbound			Southbound		Northbound	
Ramps	Mainline	Mainline	Ramps		Ramps	Mainline	Mainline	Ramps
	1863	1246			1863	1245		
-196			120	Exit 28 (Exit 22) to Rte. 1	-203			120
1242			-788		1233			-788
		1914					1913	
			60 C/B	Exit 24 (Exit 21) Rte. 1			Extended Ramp	60
			-105 C/B				Extended Ramp	-105
	2909	1959			2893	1958		
-377 C/D			161 B/C	Exit 22 (Exit 20) Rte.125/136	-367 C/D		Extended Ramp	161
703			-123 B/C		736		Extended Ramp	-133
	3235 D/C	1921			3262	1930		
			197 B/C	Exit 20 (Exit 19) Desert Road	Extended Ramp		Extended Ramp	194
-506			-352		-509		Extended Ramp	-348 B/C
269					236		Extended Ramp	
	2998	2076			2989	2084		
			583	Exit 17 (Exit 17) Rte. 1	Extended Ramp		Extended Ramp	760
-402			-216		-487 C/D		Extended Ramp	-160
517					471		Extended Ramp	
	3113 C/D	1709			2973	1484 B/A		
			-504	Exit 15 (Exit 16) Rte. 1	Extended Ramp		Extended Ramp	-332
-201					-201			
791 E/D					590			
	3703	2213 B/C			3362	1816		
			518	Exit 11 (Exit 15) Falmouth Spur	Extended Ramp		Extended Ramp	1136 B/A
-734					-1641			
	2969	1695	297	Exit 10 Bucknam Road		1721	680	138 A/B
-414			-308		-89		Extended Ramp	-615
848					1488 C/D			
	3403	1706			Extended Ramps		Extended Ramp	
					3120 C/D	1157		
825			-616	Exit 9 Rte. 1	895			-623
	4228	2322		Martins Point		4015	1780	
-349			277		-223			200

Appendix 19

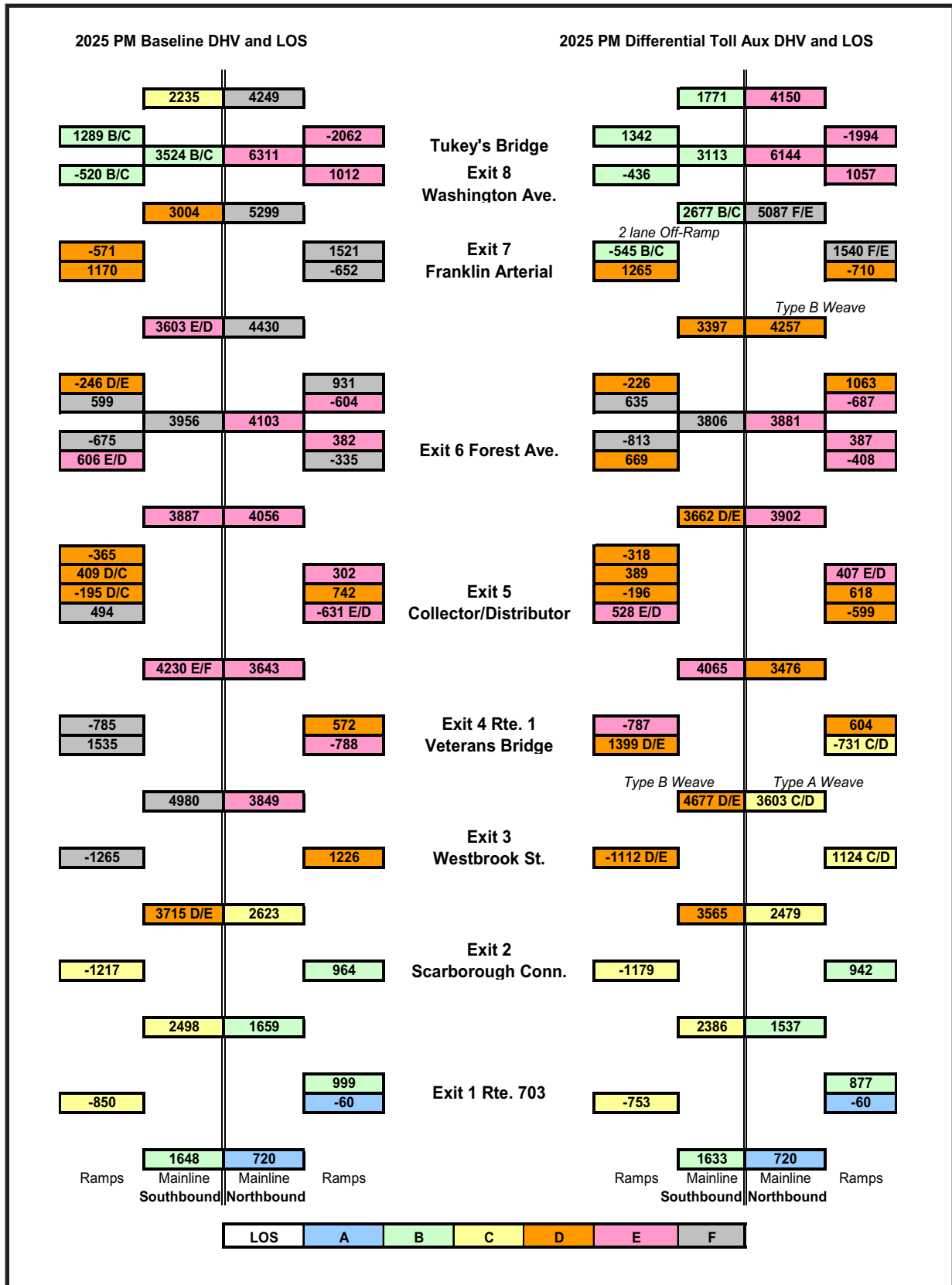

Appendix 20

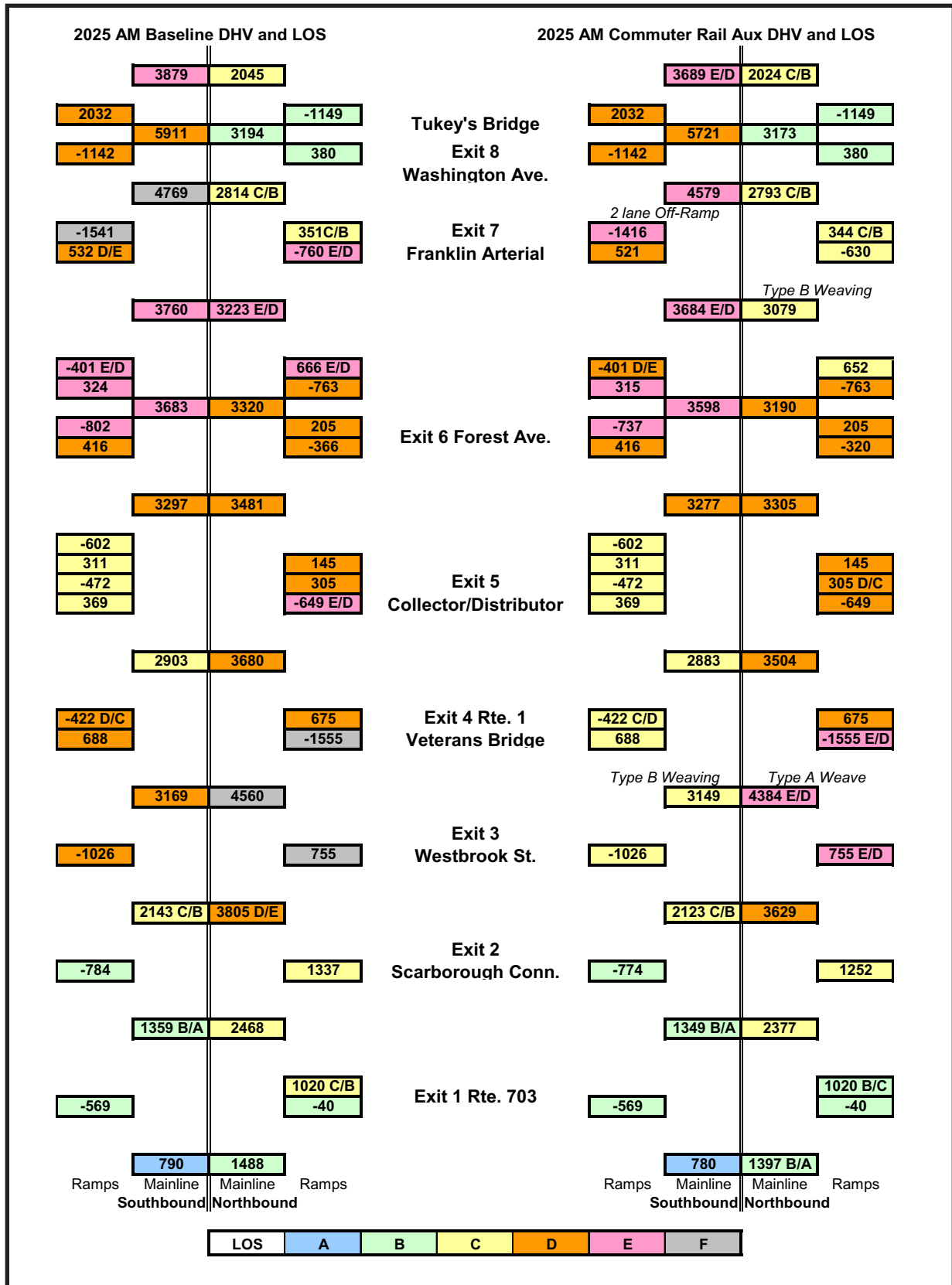

LOS	A	B	C	D	E	F
-----	---	---	---	---	---	---

2025 AM Baseline DHV and LOS

2025 AM Commuter Rail Aux DHV and LOS

2025 AM Baseline DHV and LOS					2025 AM Commuter Rail Aux DHV and LOS			
Southbound		Northbound			Southbound		Northbound	
Ramps	Mainline	Mainline	Ramps		Ramps	Mainline	Mainline	Ramps
	1863	1246			1863	1246		
-196			120	Exit 28 (Exit 22) to Rte. 1	-196			120
1242			-788		1219			-785
		1914					1911	
			60 C/B	Exit 24 (Exit 21) Rte. 1			Extended Ramp	60 C/B
			-105 C/B				Extended Ramp	-105
	2909	1959			2886	1956		
-377 C/D			161 B/C	Exit 22 (Exit 20) Rte.125/136	-377 C/D		Extended Ramp	161
703			-123 B/C		692		Extended Ramp	-123
	3235 D/C	1921			Extended Ramp		Extended Ramp	
			197 B/C	Exit 20 (Exit 19) Desert Road	-506 D/C		Extended Ramp	197
			-352		265		Extended Ramp	-351
					Extended Ramp		Extended Ramp	
	2998	2076			2960	2072		
			583	Exit 17 (Exit 17) Rte. 1	Extended Ramp		Extended Ramp	583
			-216		-402 C/D		Extended Ramp	-215
					509		Extended Ramp	
					Extended Ramp		Extended Ramp	
	3113 C/D	1709		Exit 15 (Exit 16) Rte. 1	Extended Ramp		Extended Ramp	
			-504		-201 C/D		Extended Ramp	-498
					739 C/D		Extended Ramp	
					Extended Ramp		Extended Ramp	
	3703	2213 B/C		Exit 11 (Exit 15) Falmouth Spur	Extended Ramp		Extended Ramp	
			518		-734		Extended Ramp	518
					2871	1684		
			297	Exit 10 Bucknam Road				297
			-308		-414			-298
					756		Extended Ramps	
					Extended Ramps		Extended Ramp	
	3403	1706			3213 D/C	1685		
			-616	Exit 9 Rte. 1	825 E/D			-616
			277	Martins Point		4038 E/D	2301	
					-349 E/D			277

Appendix 21

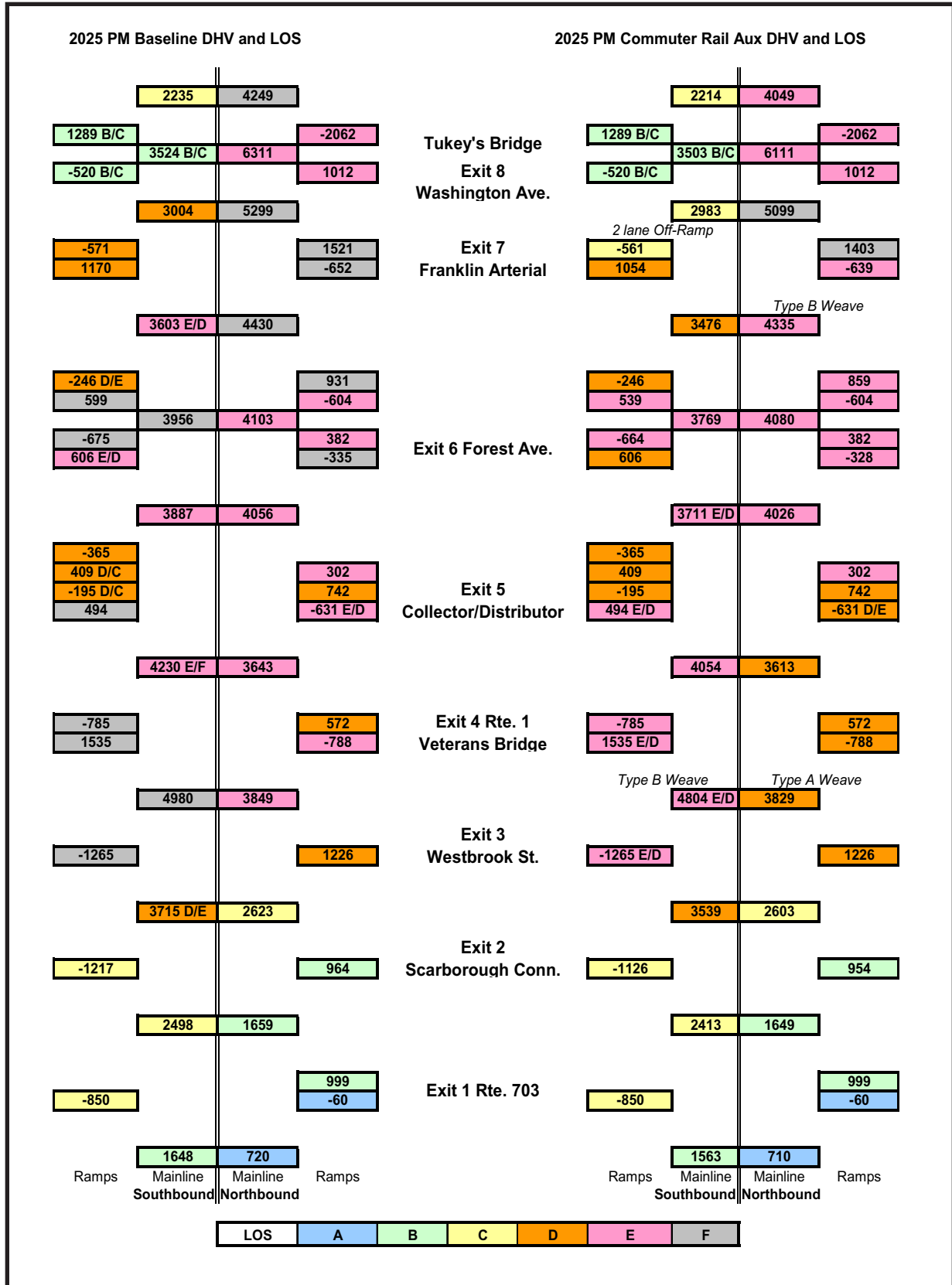



2025 PM Baseline DHV and LOS

2025 PM Commuter Rail Aux DHV and LOS

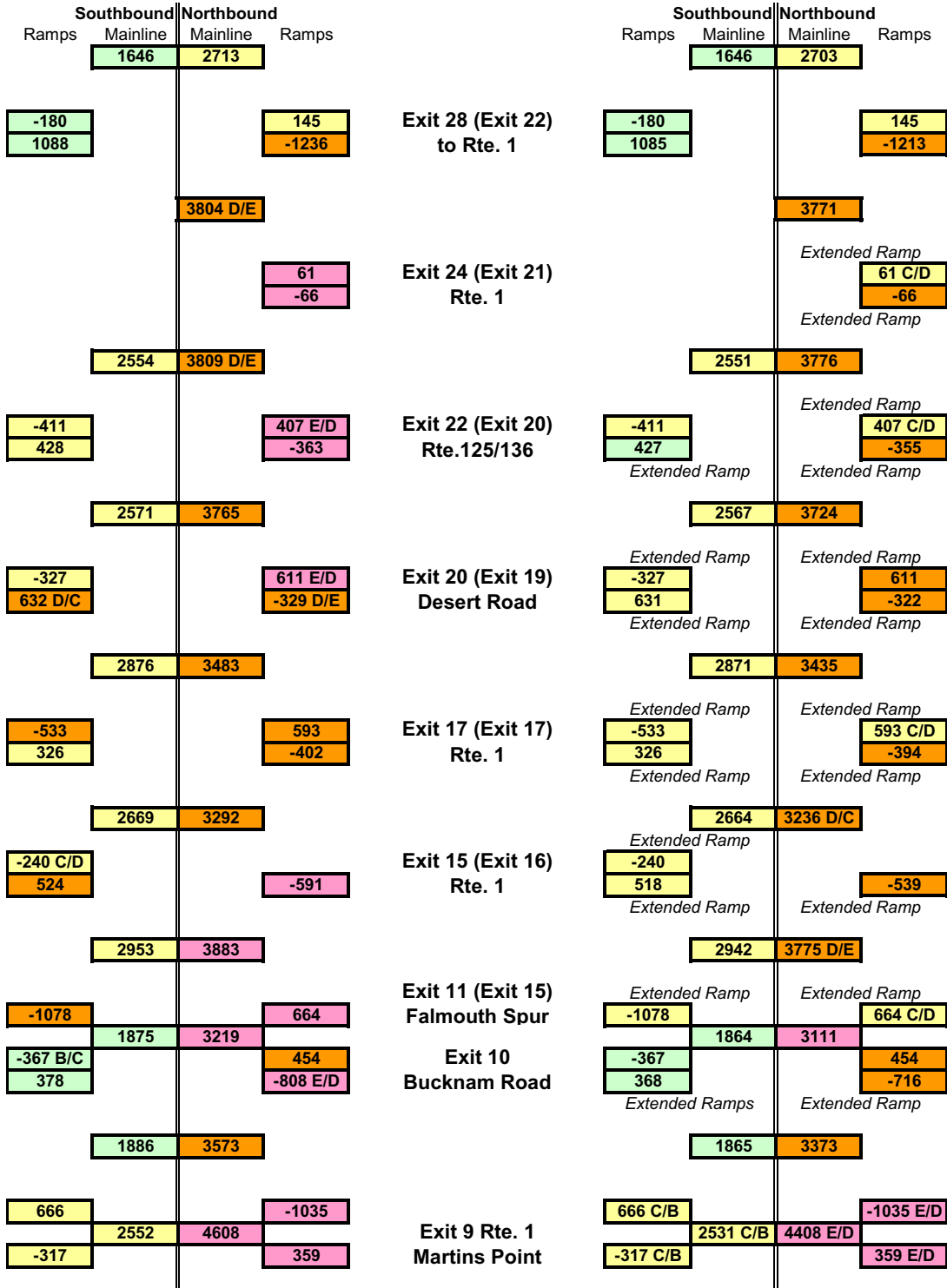

Commuter Rail Sensitivity Analysis																										
Variables	Test Levels					PARKcar			DIST\$car			IVTTcarGF		IVTTrail				FARErail			OVTTrail			5-9a mkt		
	4	8	12			4	8	12	4	4	4	4	4	4	4	4	4	4	4	4	4	4	4	4	4	
PARKcar (\$/day)	4	8	12			4	8	12	4	4	4	4	4	4	4	4	4	4	4	4	4	4	4	4	4	
DIST\$car (\$/veh-mi)	0.12	0.24	0.36			0.12	0.12	0.12	0.12	0.24	0.36	0.12	0.12	0.12	0.12	0.12	0.12	0.12	0.12	0.12	0.12	0.12	0.12	0.12	0.12	
IVTTcarGF (travel time growth)	1	1.2	1.5			1.0	1.0	1.0	1.0	1.0	1.0	1.0	1.2	1.5	1.0	1.0	1.0	1.0	1.0	1.0	1.0	1.0	1.0	1.0	1.0	
IVTTTrail (travel time growth)	1	1.2	1.5		2	1.2	1.2	1.2	1.2	1.2	1.2	1.2	1.2	1.2	1.0	1.2	1.5	2.0	1.2	1.2	1.2	1.2	1.2	1.2	1.2	
FARErail (\$/pass-mi)	0.10	0.20	0.30			0.10	0.10	0.10	0.10	0.10	0.10	0.10	0.10	0.10	0.10	0.10	0.10	0.10	0.10	0.20	0.30	0.10	0.10	0.10	0.10	
OVTTrail (out-of-veh minutes)		40	30		25	25	25	25	25	25	25	25	25	25	25	25	25	25	25	25	25	25	40	30	25	
5-9a mkt (growth in commuters)	1.15	1.20				1.15	1.15	1.15	1.15	1.15	1.15	1.15	1.15	1.15	1.15	1.15	1.15	1.15	1.15	1.15	1.15	1.15	1.15	1.15	1.20	
Potential Stations																										
North Berwick	3					2	2	2	2	2	2	2	3	7	4	2	1	0	2	2	2	1	1	2	2	2
Wells	7	10				5	5	5	5	5	5	5	7	12	8	5	2	0	5	4	4	2	4	5	5	5
Kennebunk	26	26	35			19	19	20	19	20	20	19	26	39	29	19	10	3	19	19	18	9	15	19	19	20
Biddeford	15	15	15	51		11	11	11	11	11	11	11	15	27	19	11	5	1	11	10	10	5	8	11	11	11
Saco	158	158	158	158	208	131	134	136	131	133	135	131	158	208	173	131	87	44	131	129	127	64	103	131	131	137
Old Orchard Beach	46	46	46	46	46	38	38	39	38	38	39	38	46	60	50	38	25	12	38	37	37	18	30	38	38	39
Scarborough	150	150	150	150	150	136	139	141	136	137	138	136	150	174	158	136	109	74	136	135	134	67	108	136	136	142
Falmouth	181	181	181	181	437	159	162	165	159	161	162	159	181	220	193	159	120	76	159	158	156	78	126	159	159	166
Yarmouth	103	120	120	225		89	91	93	89	90	92	89	103	129	111	89	64	37	89	88	87	44	71	89	89	93
Freeport	51	51	105			42	42	43	42	42	43	42	51	71	57	42	26	12	42	41	40	20	33	42	42	43
Brunswick	50	54				36	36	37	36	37	38	36	50	81	59	36	17	5	36	35	34	17	28	36	36	37
Bath	4					3	3	3	3	3	3	3	4	8	5	3	1	0	3	3	3	1	2	3	3	3
New Gloucester	17					13	13	13	13	13	13	13	17	26	19	13	7	2	13	12	12	6	10	13	13	13
Auburn	30	30	30	30		19	20	20	19	20	21	19	30	60	38	19	7	1	19	18	18	9	15	19	19	20
Inbound Commuters	841	841	841	841	841	701	714	728	701	712	722	701	841	1122	923	701	478	268	701	691	682	341	553	701	701	732
Commuter Bus Sensitivity Analysis																										
Variables	Test Levels					PARKcar			DIST\$car			IVTTcarGF		IVTTbus				FAREbus			OVTTbus			5-9a mkt		
	4	8	12			4	8	12	4	4	4	4	4	4	4	4	4	4	4	4	4	4	4	4	4	
PARKcar (\$/day)	4	8	12			4	8	12	4	4	4	4	4	4	4	4	4	4	4	4	4	4	4	4	4	
DIST\$car (\$/veh-mi)	0.12	0.24	0.36			0.12	0.12	0.12	0.12	0.24	0.36	0.12	0.12	0.12	0.12	0.12	0.12	0.12	0.12	0.12	0.12	0.12	0.12	0.12	0.12	
IVTTcarGF (travel time growth)	1	1.2	1.5			1	1	1	1	1	1	1	1.2	1.5	1	1	1	1	1	1	1	1	1	1	1	
IVTTbus (travel time growth)	1	1.2	1.5		2	1.2	1.2	1.2	1.2	1.2	1.2	1.2	1.2	1.2	1	1.2	1.5	2	1.2	1.2	1.2	1.2	1.2	1.2	1.2	
FAREbus (\$/pass-mi)	0.10	0.20	0.30			0.10	0.10	0.10	0.10	0.10	0.10	0.10	0.10	0.10	0.10	0.10	0.10	0.10	0.10	0.20	0.30	0.10	0.10	0.10	0.10	
OVTTbus (out-of-veh minutes)		40	30		25	25	25	25	25	25	25	25	25	25	25	25	25	25	25	25	25	25	40	30	25	
5-9a mkt (growth in commuters)	1.15	1.20				1.15	1.15	1.15	1.15	1.15	1.15	1.15	1.15	1.15	1.15	1.15	1.15	1.15	1.15	1.15	1.15	1.15	1.15	1.15	1.20	
Inbound Commuters	581.2					668.6	681.4	694.5	668.6	704.8	715.4	668.6	581.2	474.7	881.2	668.6	455.6	255.2	668.6	659.2	649.9	324.6	526.7	668.6	668.6	697.7

Appendix 23

23-1 Exit 7

23-2 Exit 4

23-3 Exit 5-7

23-4 Forest Ave.

23-5 Falmouth Spur

23-6 Exit 15



