

DIVISION 200
EARTHWORK

Remove existing pavement surface to construct butt joint between existing and proposed bituminous pavements

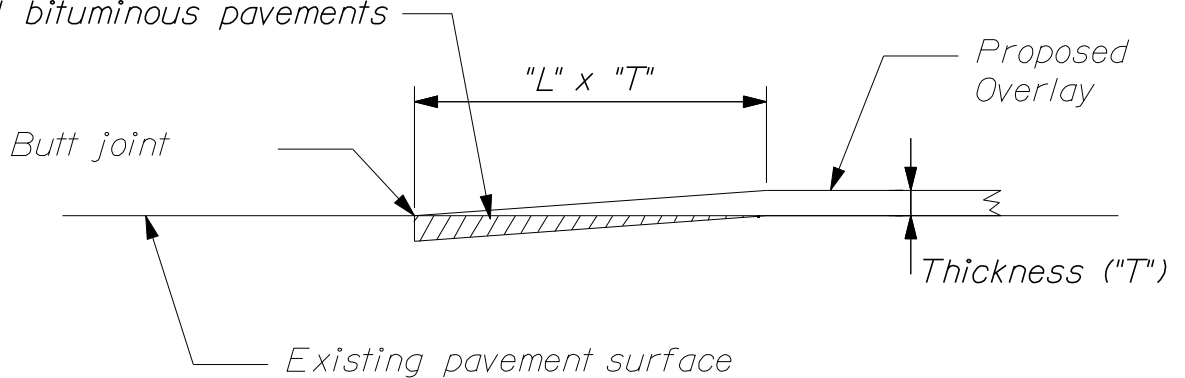

Design or posted speed (miles/h):	65	55	50	45	40	35	30	25
"L" in feet/inch of thickness:	65	55	50	45	40	35	30	25

NOTES:

1. The above lengths are intended for profile grades of 2% or less. When profile grades are greater than 2% "L" may be adjusted to suit field conditions when directed by the Resident.
2. When constructing Butt Joints at intersections or ramps "L" shall be 15' / inch of thickness unless otherwise directed by the Resident.
3. Special attention shall be paid to curb sections to assure proper drainage and that there are no flat areas. "L" may be adjusted to suit field conditions when directed by the Resident.

**PAVEMENT OVERLAY
BUTT JOINT DETAIL (ROADWAYS)
202(01)**

NOTE:

When muck is excavated to a depth greater or less than what is shown on the plans, the lateral limits for payment shall be determined as shown or as specifically directed by the Resident.

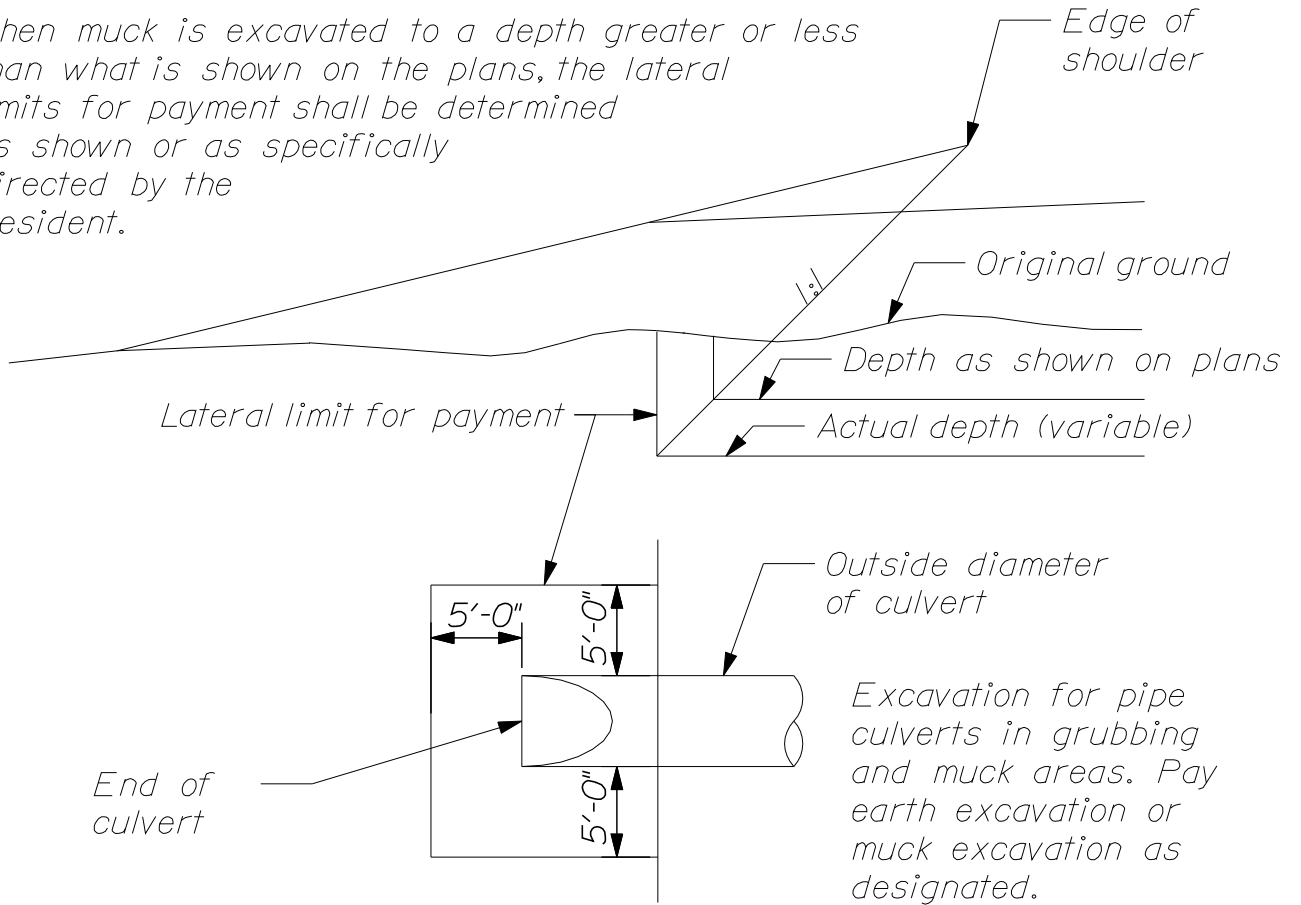

~ MUCK EXCAVATION PAY LIMITS ~

Note:

When directed by the Resident, waste material shall be used in this area except that waste shall not be placed in fills designed with slopes of 2:1 or steeper. No additional payment will be made for this work.

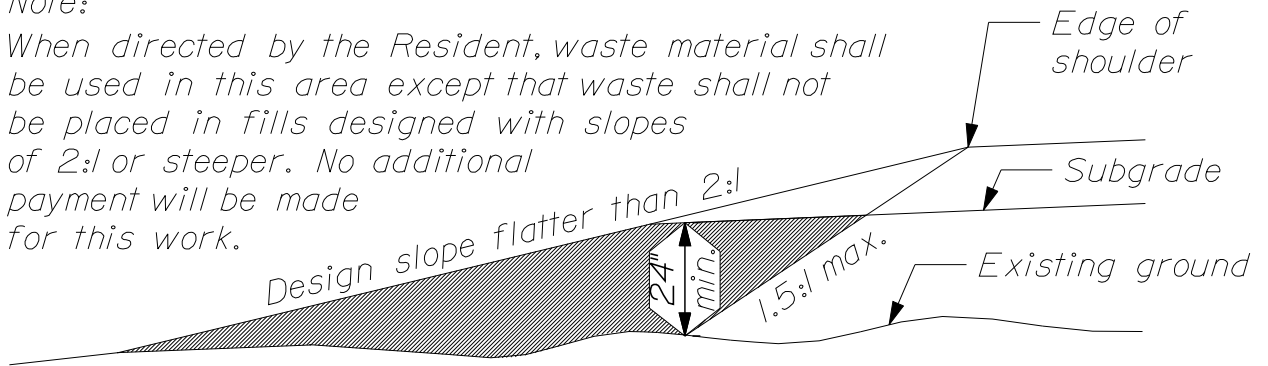

~ DISPOSAL OF WASTE MATERIALS ~
(Waste Storage Area)

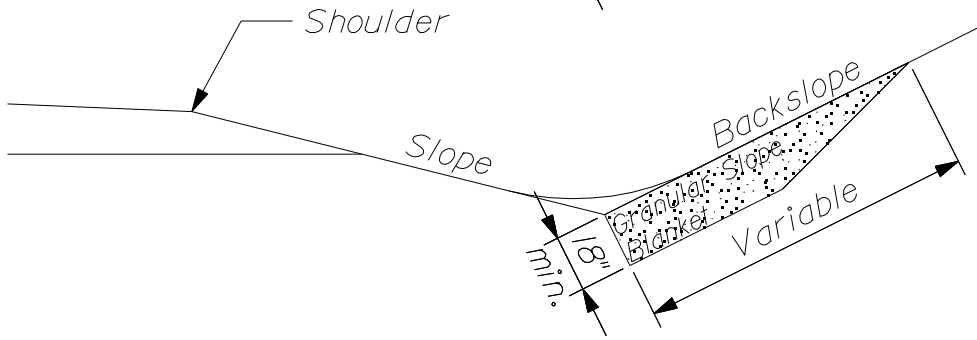
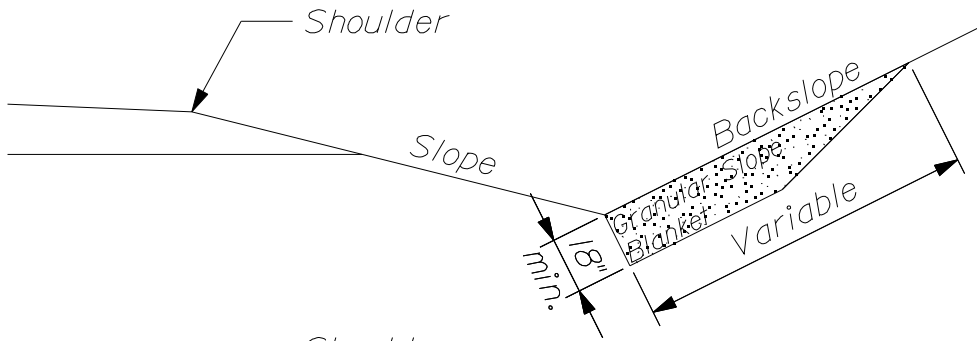

~ SLOPE BLANKET - BACKSLOPE ~

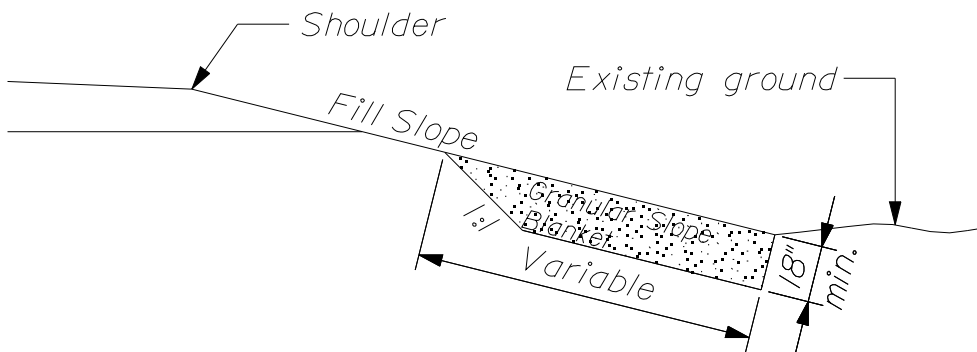

~ SLOPE BLANKET - FILL SLOPE ~

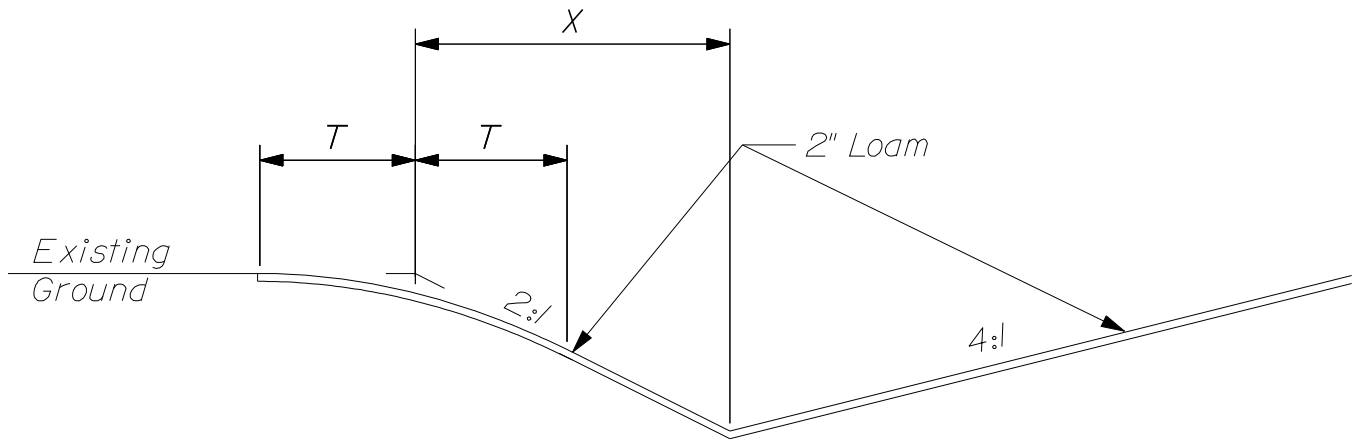

When:

$X > 5'$, Then $T = 5'$

$X \leq 5'$, Then $T = X$

This formula may be modified in the field by the Resident to avoid property damage.