

**MAINE DEPARTMENT OF TRANSPORTATION
BRIDGE PROGRAM
GEOTECHNICAL SECTION
AUGUSTA, MAINE**

GEOTECHNICAL DESIGN REPORT

For the Replacement of:

**GREAT FARM BRIDGE
STATE ROUTE 7 OVER GREAT FARM BROOK
JACKSON, MAINE**

Prepared by:

James Manahan
Assistant Transportation Engineer

Reviewed by:

Laura Krusinski, P.E.
Senior Geotechnical Engineer



Laura Krusinski

Waldo County
WIN 23567.00

Soils Report 2021-06
Bridge No. 3128

March 15, 2021
Federal Project No. 2356700

Table of Contents

1.0 INTRODUCTION..... 1

2.0 GEOLOGIC SETTING 1

3.0 SUBSURFACE INVESTIGATION 2

4.0 LABORATORY TESTING 2

5.0 SUBSURFACE CONDITIONS 3

 5.1 FILL..... 3

 5.2 STREAM ALLUVIUM 3

 5.3 STREAM TERRACE DEPOSITS..... 3

 5.4 GLACIAL TILL 4

 5.5 BEDROCK 4

 5.6 GROUNDWATER 5

6.0 FOUNDATION ALTERNATIVES..... 5

7.0 GEOTECHNICAL DESIGN CONSIDERATIONS AND RECOMMENDATIONS. 5

 7.1 PRECAST CONCRETE BOX CULVERT DESIGN AND CONSTRUCTION 5

 7.1.1 PRECAST CONCRETE BOX CULVERT HEADWALLS 6

 7.1.2 PRECAST CONCRETE INLET AND OUTLET WALLS 6

 7.1.3 PRECAST CONCRETE INLET AND OUTLET TOE WALLS 6

 7.1.4 BEARING RESISTANCE..... 7

 7.1.5 MODULUS OF SUBGRADE REACTION..... 7

 7.2 SUBGRADE PREPARATION FOR BOX CULVERT 7

 7.3 SETTLEMENT 7

 7.4 FROST PROTECTION..... 8

 7.5 SCOUR AND RIPRAP..... 8

 7.6 SEISMIC DESIGN CONSIDERATIONS 8

8.0 CONSTRUCTION CONSIDERATIONS 9

9.0 CLOSURE 9

Sheets

Sheet 1 – Location Map

Sheet 2 – Boring Location Plan and Interpretive Subsurface Profile

Sheet 3 – Boring Logs

Appendices

Appendix A – Boring Logs

Appendix B – Rock Core Photographs

Appendix C – Laboratory Test Results

Appendix D – Calculations

1.0 INTRODUCTION

The purpose of this Geotechnical Design Report is to present subsurface information and provide geotechnical design recommendations for the replacement of Great Farm Bridge which carries State Route 7 (Great Farm Road) over Great Farm Brook in Jackson, Maine. This report presents the subsurface information obtained at the site during the subsurface investigation, geotechnical design parameters, and construction recommendations for the new box culvert.

The Great Farm Bridge was constructed in 1938. The structure consists of a single-span, steel beam superstructure supported on mass concrete abutments bearing on soil. According to the 2018 Maine Department of Transportation (MaineDOT) Bridge Inspection Report, the bridge is structurally deficient. The substructure is rated a 6 (satisfactory) with widespread minor cracking and minor scaling below the waterline in the wingwalls and abutments, with deep scaling at the southwest bearing area.

The proposed replacement structure is a 26-foot span and 9-foot rise, 88-foot long, precast concrete box culvert. The box culvert shall have 1-foot tall precast headwalls and 2-foot deep toe walls at the inlet and outlet. The upstream and downstream ends of the culvert will be slope-tapered at 1.75H:1V (horizontal:vertical). The box culvert invert will be embedded 3 feet into the streambed and 3 feet of special fill will be placed inside the bottom of the culvert to create a natural streambed. The box shall be placed on a 1-foot-thick leveling layer of Granular Borrow – Material for Underwater Backfill.

The new box culvert will be located on a new horizontal alignment which shifts the centerline approximately 1-foot downstream. The proposed vertical alignment will raise the profile approximately 4-inches across the new bridge. Traffic will be maintained by one lane alternating one-way traffic on a temporary bridge located on the downstream side.

2.0 GEOLOGIC SETTING

Great Farm Bridge carries State Route 7 (Great Farm Road) over Great Farm Brook as shown on Sheet 1 – Location Map.

The Maine Geological Survey (MGS) Surficial Geology Map of the Brooks West Quadrangle, Open-File No. 14-8 (2014), indicates the surficial soils in the vicinity of the bridge project consist of stream alluvium, with stream terraces and glacial till mapped nearby. Stream alluvium is typically a sand, silt, gravel and organic sediment deposited on floodplains of streams.

The MGS Bedrock Geology of the Brooks Quadrangle Open File No. 18-14 (2018) maps the bedrock at the project site as undifferentiated Granofels, interlayered with Schist, of the Vassalboro group.

3.0 SUBSURFACE INVESTIGATION

Two test borings explored subsurface conditions at the project location. Boring BB-JGFB-101 was drilled through bridge deck in the southwest corner of the bridge. Boring BB-JGFB-102 was drilled behind the abutment at the northeast corner of the bridge. Both borings terminated in bedrock cores. The test boring locations are shown on Sheet 2 – Boring Location Plan and Interpretive Subsurface Profile.

The test borings were drilled on June 1 and 2, 2020. Details and sampling methods used, field data obtained, and soil and groundwater conditions encountered are presented in the boring logs provided in Appendix A – Boring Logs and on Sheet 3 – Boring Logs.

Borings were performed by using a combination of solid stem auger, cased wash boring, and rock coring techniques. The borings were completed by backfilling and compacting the borehole with drill cuttings. Soil samples were typically obtained at 5-foot intervals using Standard Penetration Test (SPT) methods. During SPT sampling, the sampler is driven 24 inches and the hammer blows for each 6-inch interval of penetration are recorded. The sum of the blows for the second and third intervals is the N-value, or standard penetration resistance. The drill rig is equipped with an automatic hammer to drive the split spoon. The hammer was calibrated per ASTM D4633 “Standard Test Method for Energy Measurement for Dynamic Penetrometers” in June 2019. All N-values discussed in this report are corrected values computed by applying an average energy transfer of 0.977 to the raw field N-values. This hammer efficiency factor (0.977) and both the raw field N-value and corrected N-value (N_{60}) are shown on the boring logs.

Bedrock was cored in the borings using an NQ-2” core barrel and the Rock Quality Designation (RQD) of the cores calculated. The MaineDOT geotechnical engineer selected the boring locations and drilling methods, designated type and depth of sampling techniques, identified field-testing requirements, and logged the subsurface conditions encountered in the borings. The borings were located in the field using taped measurements at the completion of the drilling program and then located by MaineDOT Survey.

4.0 LABORATORY TESTING

A laboratory testing program was conducted on selected soil samples recovered from the test borings to assist in soil classification, evaluation of engineering properties of the soils, and geologic assessment of the project site. Laboratory testing consisted of four standard grain size analyses with natural water content, two grain size analyses with hydrometer and natural water content, and two Atterberg limit tests. The results of soil tests are included as Appendix C – Laboratory Test Results. Moisture content information and other soil test results are also shown on the boring logs provided in Appendix A – Boring Logs and on Sheet 3 – Boring Logs.

5.0 SUBSURFACE CONDITIONS

Subsurface conditions encountered in the test borings generally consisted of Alluvium, Fill, Post-Glacial Stream Terrace Deposit, Glacial Till and metamorphic Bedrock. The boring logs are provided in Appendix A – Boring Logs and on Sheet 3 – Boring Logs. A generalized subsurface profile is shown on Sheet 2 – Boring Location Plan and Interpretive Subsurface Profile. The following paragraphs summarize the subsurface conditions encountered:

5.1 Fill

A layer of fill was encountered in the boring BB-JGFB-102. The thickness was approximately 8.5 feet. The unit consisted of light to dark brown, damp, very dense SAND, some silt, little gravel. One SPT test in the Fill unit could not be advanced the required 24-inches, indicating the presence of cobbles.

5.2 Stream Alluvium

A layer of Stream Alluvium was encountered in the test borings. The thickness was approximately 8 to 17.5 feet. The unit generally consisted of:

- Grey, wet, Sandy SILT, little gravel;
- Grey, wet, SILT, some gravel, little sand;
- Light to dark brown, damp, SAND, some silt, little gravel;
- Olive, wet, fine to medium Sandy SILT, trace clay, trace gravel;
- Grey, wet, SAND, some silt, little gravel.

Corrected SPT N-values for the coarse-grained alluvial soils layer ranged from 34 to 57 blows per foot (bpf), indicating these soils are medium dense to very dense in consistency. Corrected SPT N-values in the fine-grained (silty) layers ranged from 18 to 24 blows per foot (bpf), indicating the silt is very stiff in consistency. Two Atterberg limits tests classified the silts as non-plastic. Two grain size analyses resulted in the material being classified as A-4 under the AASHTO Soil Classification System and CL under the Unified Soil Classification System (USCS). The natural water contents of the samples tested ranged from approximately 13 to 46 percent.

5.3 Stream Terrace Deposits

Stream Terrace Deposits were encountered beneath the Alluvium. The deposits encountered generally consisted of:

- Light brown, wet, Gravelly SAND, some silt;
- Light brown to grey, wet, SAND, little to some gravel, trace to little silt.

Corrected SPT N-values in the layer ranged from 18 to 26 bpf, indicating the layer is medium dense in consistency. Two grain size analyses conducted on samples from the Stream Terrace Deposits classified the material as A-1-b under the AASHTO Soil Classification System and SM and SW-SM under the USCS. The natural water contents of the samples tested ranged from approximately 9 to 14 percent.

5.4 Glacial Till

Glacial Till was encountered beneath the Stream Terrace Deposits. The Glacial Till encountered generally consisted of:

- Dark grey, wet, SAND, some silt, little gravel;
- Grey, damp, SILT some sand, some gravel.

One corrected SPT N-value of 94 bpf was recorded in the coarse-grained Glacial Till indicating the layer is very dense in consistency. One corrected SPT N-value of 116 bpf was recorded in the fine-grained, silty Glacial Till, indicating the layer is hard in consistency. Grain size analyses conducted on samples indicated the material is classified as A-2-4 and A-4 under the AASHTO Soil Classification System and SM under the USCS. The natural water contents of the samples tested were approximately 12 percent.

5.5 Bedrock

Bedrock was encountered and cored in both borings. The following table summarizes approximate depth to bedrock, corresponding approximate top of bedrock elevation, and RQD.

Boring	Station	Offset (feet)	Approximate Depth to Bedrock (feet)	Approximate Elevation of Bedrock Surface (feet)	RQD (%), (R1, R2)
BB-JGFB-101	9+86.9	9.1 Lt	24.3	402.0	20, 61
BB-JGFB-102	10+14.5	5.4 Rt	34.6	401.5	77, 97

The bedrock at the site is identified as grey, fine-grained, hard, fresh, Metasandstone (metamorphosed Gneiss/Granofels) with quartz and calcite veins. The RQD of the bedrock ranged from 20 to 97 percent corresponding to a rock quality of very poor to excellent. Detailed bedrock descriptions and RQD are provided in Appendix A – Boring Logs and on Sheet 3 – Boring Logs. Rock core photographs are included in Appendix B – Rock Core Photographs.

5.6 Groundwater

Groundwater was measured at 8.4 feet below the roadway surface upon completion of boring BB-JGFB-102. Boring BB-JGFB-101 was a water boring with water above ground surface. Note that water was introduced into the boreholes during drilling operations and the measured level may not represent stabilized groundwater elevation. Groundwater levels will fluctuate with seasonal changes, precipitation, runoff, river levels, and construction activities.

6.0 FOUNDATION ALTERNATIVES

Initially two bridge rehabilitation options were considered, in addition to bridge replacement. The construction estimates for both rehabilitation options were costly. Ultimately, replacing the existing bridge was determined to be the best value alternative when the Environmental Office provided a bankfull width that could be accommodated with a 26-foot span by 9-foot rise precast box culvert.

7.0 GEOTECHNICAL DESIGN CONSIDERATIONS AND RECOMMENDATIONS

7.1 Precast Concrete Box Culvert Design and Construction

The proposed replacement structure will consist of a 88-foot-long precast concrete box culvert with slope tapered inlet and outlet walls. The box culvert will have 1-foot tall precast headwalls. To prevent undermining, the box culvert will have 2-foot tall inlet and outlet toe walls and riprap aprons. The bottom slab of the box culvert will be embedded approximately 3 feet into the streambed and 3 feet of engineered streambed material will be placed inside the culvert to create a natural streambed. 2-foot thick riprap aprons should be constructed at the inlet and outlet and should be embedded a minimum of 6 inches into the streambed. The riprap aprons will be covered with the engineered streambed material to provide continuity of the natural streambed.

Precast concrete box culverts are typically supplier-designed and are detailed on the contract plans with only basic layout and required hydraulic opening. The manufacturer selected by the Contractor is responsible for the design of the structure including determination of wall thickness, haunch thickness, and reinforcement. The design shall be designed in accordance with MaineDOT Standard Specification 534 – Precast Structural Concrete, MaineDOT Bridge Design Guide (BDG) Section 8 – Buried Structures, and American Association of State Highway and Transportation Officials Load Resistance and Factor Design Bridge Design Specifications, 9th Edition, 2020.

The loading specified for the design of the box shall be Modified HL-93 Strength I in which the HS-20 design truck wheel loads are increased by a factor of 1.25. The precast concrete box culvert shall be designed for all relevant strength and service limit states and load combinations specified in LRFD Article 3.4.1 and LRFD Section 12. The design should use Soil Type 4 as presented in the MaineDOT BDG Section 3.6 to calculate earth loads and earth pressures from the soil envelope. The backfill properties are as follows: $\phi = 32^\circ$, $\gamma = 125$ pcf.

The box culvert will be bedded on a 1-foot-thick leveling layer of Granular Borrow – Material for Underwater Backfill conforming to Standard Specification 703.19 underlain by a layer of separation/reinforcement geotextile. The soil envelope and backfill shall consist of Standard Specification 703.19 – Granular Borrow Material for Underwater Backfill with a maximum particle size of 4 inches. The granular borrow backfill should be placed in lifts of 6 to 8 inches thick loose measure and compacted to the manufacturer’s specifications. In no case shall the backfill soil be compacted less than 92 percent of the AASHTO T-180 maximum dry density. The precast concrete box culvert shall be installed in conformance with MaineDOT BDG Section 8 and MaineDOT Standard Specification Section 534.

7.1.1 Precast Concrete Box Culvert Headwalls

Concrete headwalls will be included in the culvert design to retain crushed stone slope protection and prevent stones from dropping or eroding into the waterway. Nominal 1-foot thick by 1-foot high concrete headwalls are recommended.

7.1.2 Precast Concrete Inlet and Outlet Walls

The precast concrete box culvert’s outlet and inlet walls will be slope-tapered to match the side slopes. The left and right outlet walls will share the same precast base slab. The sloped inlet and outlet walls are essentially retaining walls and shall be designed for all relevant strength and service limit states and load combinations specified in LRFD Articles 3.4.1, 11.5.5 and 11.6. The inlet and outlet walls shall be designed to resist lateral earth pressures, vehicular loads and forces resulting from creep, temperature and shrinkage deformations of the concrete box culvert. The inlet and outlet walls shall be designed considering a live load surcharge equal to a uniform horizontal earth pressure due to an equivalent height of soil (h_{eq}) of 2.0 feet per LRFD Article 3.11.6.4. Passive pressure resulting from the embedment of the box culvert and walls with engineered streambed, or any other material shall not contribute to resisting forces.

Inlet and outlet walls that are fixed to the box culvert should be designed to resist movement using an at-rest earth pressure coefficient, K_o , of 0.47. Wingwalls sections that are independent of the box culvert and free to rotate should be designed using the Rankine active earth pressure coefficient, K_a , of 0.46 assuming a 2H:1V backslope. The active earth pressure coefficient will change if the backslope conditions are different. See Appendix D – Calculations for supporting documentation.

7.1.3 Precast Concrete Inlet and Outlet Toe Walls

Toe walls shall extend below the bottom slab connecting the left and right walls at the inlet and outlet of the box culvert to prevent undermining per MaineDOT BDG Section 8.3.1. The inlet and outlet toe walls should extend a minimum of 1 foot below the maximum depth of scour.

7.1.4 Bearing Resistance

The precast concrete box culvert will be bedded on a 1-foot-thick layer of Granular Borrow – Material for Underwater Backfill with a bottom elevation ranging from approximately El. 420.0 to 421.5 feet.

For a precast concrete box culvert with a base width of 28 feet, the factored bearing stress at the strength limit state shall not exceed the calculated factored bearing resistance of 12 kips per square foot (ksf). To control settlement, the factored bearing stress at the service limit state shall not exceed a bearing resistance of 6 ksf. Due to the large size of the concrete box culvert base, controlling deflection and not bearing resistance may govern the design. The service limit state bearing resistance may govern the design. In no instance shall bearing stress exceed the nominal structural resistance of the structural concrete which may be taken as $0.3f'_c$. See Appendix D – Calculations for supporting calculations.

7.1.5 Modulus of Subgrade Reaction

Large span precast box culverts can be viewed similarly to a mat foundation. A common approach to the design of precast box culverts is to use beam on elastic foundation theory to compute the soil-structure interaction and deflections.

The modulus of subgrade reaction relates the box culvert bearing pressure to settlement and is often used in soil-structure interaction analyses. The modulus of subgrade reaction is dependent on many factors including the material properties and thickness of the bearing soils, geometry of the box culvert, and the stiffness of the box culvert. The box culvert shall be designed using a modulus of subgrade reaction, k_s , equal to 72 pounds per cubic inch (pci).

7.2 Subgrade Preparation for Box Culvert

The alluvial soils encountered in borings at the box subgrade elevation consisted of medium dense sands and silt. Any unsuitable soils (i.e. low strength silts and clays and loose sands), that are encountered at the subgrade elevation, should be excavated down to expose competent, firm material and replaced with compacted granular borrow. This recommendation should be included in the contract documents as a General Note.

7.3 Settlement

The alluvial deposits encountered at the site are either very stiff silts or medium dense to very dense sand. The underlying stream terrace deposits are medium dense granular soils. These materials undergo elastic, immediate, compression in response to an increase of vertical overburden pressure. The proposed vertical alignment will remain nearly the same as the existing vertical alignment. As a result, little to no increase in vertical overburden pressure is expected. Any settlement is anticipated to be small and will occur relatively quickly.

Any loose soils or silts encountered at the subgrade elevation for the precast box culvert should be excavated in its entirety and replaced with compacted Granular Borrow – Material for Underwater Backfill. With these provisions, post-construction settlement at the location of the replacement structure is anticipated to be minimal.

7.4 Frost Protection

Foundations placed on the fill or native soils should be designed with an appropriate embedment for frost protection. According to MaineDOT BDG Figure 5-1, Maine Design Freezing Index Map, Jackson has a design freezing index (DFI) of approximately 1600 F-degree days. A water content of 15% was used for fine-grained soils. These components correlate to a frost depth of 4.7 feet.

It is recommended that foundations bearing on soil be designed with an embedment of approximately 4.7 feet for frost protection.

Riprap is not to be considered as contributing to the overall thickness of soils required for frost protection.

7.5 Scour and Riprap

The box culvert shall be constructed with integral concrete headwalls and inlet and outlet walls to retain stone slopes and prevent stone slope protection from dropping or eroding into the waterway. Inlet and outlet toe walls shall be provided that extend a minimum of 1-foot below the maximum depth of scour. Inlet and outlet toe walls shall also be protected with riprap aprons.

Where required, slopes shall be armored with a 3-foot thick layer of riprap conforming to MaineDOT Standard Specification 703.26 – Plain and Hand Laid Riprap. The riprap shall be underlain by a Class 1 erosion control geotextile and a 1-foot layer of bedding material conforming to MaineDOT Standard Specification 703.19 Granular Borrow Material for Underwater Backfill. The toe of the riprap sections shall be constructed 1-foot below the streambed elevation. The riprap slopes shall be constructed no steeper than 1.75H:1V extending from the edge of the roadway down to the existing ground surface.

7.6 Seismic Design Considerations

In conformance with LRFD Article 3.10.1, seismic analysis is not required for buried structures, except where they cross active faults. There are no known active faults in Maine; therefore, seismic analysis is not required.

8.0 CONSTRUCTION CONSIDERATIONS

The soil envelope and backfill for the box culvert shall consist of Standard Specification 703.19 – Granular Borrow Material for Underwater Backfill with a maximum particle size of 4 inches. The granular borrow backfill should be placed in lifts of 6- to 8-inches-thick loose measure and compacted to the manufacturer’s specifications. To minimize future settlement, the envelope and backfill soil shall be compacted to no less than 92 percent of the AASHTO T-180 maximum dry density.

The proposed box culvert will be bedded on a 1-foot-thick layer of Granular Borrow – Material for Underwater Backfill, conforming to Standard Specification 703.19. Fine-grained stream alluvium was encountered in the test borings at the proposed culvert subgrade. Any unsuitable soils (i.e. low strength silts, clays, organics, and loose sands) that are encountered at the subgrade shall be excavated down to expose competent, firm material and replaced with compacted granular borrow.

The Contractor shall minimize disturbance to the subgrade surface and protect the subgrade surface from any unnecessary construction traffic. Any soft soils or organic material encountered at the bearing elevation shall be removed and replaced with compacted Granular Borrow – Material for Underwater Backfill.

Earthwork and excavations may result in the exposure of silt or other soft soils. These soils may be susceptible to disturbance and rutting as a result of exposure to water or construction traffic. If disturbance and rutting occur, the Contractor shall remove and replace the disturbed materials with compacted Granular Borrow – Material for Underwater Backfill.

Soils may become saturated and water seepage may be encountered during construction and in excavations. There may be localized sloughing and instability in some excavations and cut slopes. The Contractor should control groundwater and surface water infiltration using temporary ditches, sump pumps, granular drainage blankets, stone ditch protection, or hand-laid riprap with geotextile underlayment to divert groundwater and surface water.

9.0 CLOSURE

This report has been prepared for the use of the MaineDOT Bridge Program for specific application to the proposed replacement of Great Farm Bridge in Jackson, Maine in accordance with generally accepted geotechnical and foundation engineering practices. No other intended use or warranty is expressed or implied.

In the event that any changes in the nature, design, or location of the proposed project are planned, this report should be reviewed by a geotechnical engineer to assess the appropriateness of the conclusions and recommendations and to modify the recommendations as appropriate to reflect the changes in design. These analyses and recommendations are based in part upon limited subsurface investigations at discrete exploratory locations completed at the site. If variations from the conditions encountered during the investigation appear evident during construction, it may also become necessary to re-evaluate the recommendations made in this report.

It is recommended that the geotechnical engineer be provided the opportunity for a review of the design and specifications so that the earthwork and foundation recommendations and construction considerations in the report are properly interpreted and implemented in the design and specifications.

Sheets



JACKSON, MAINE

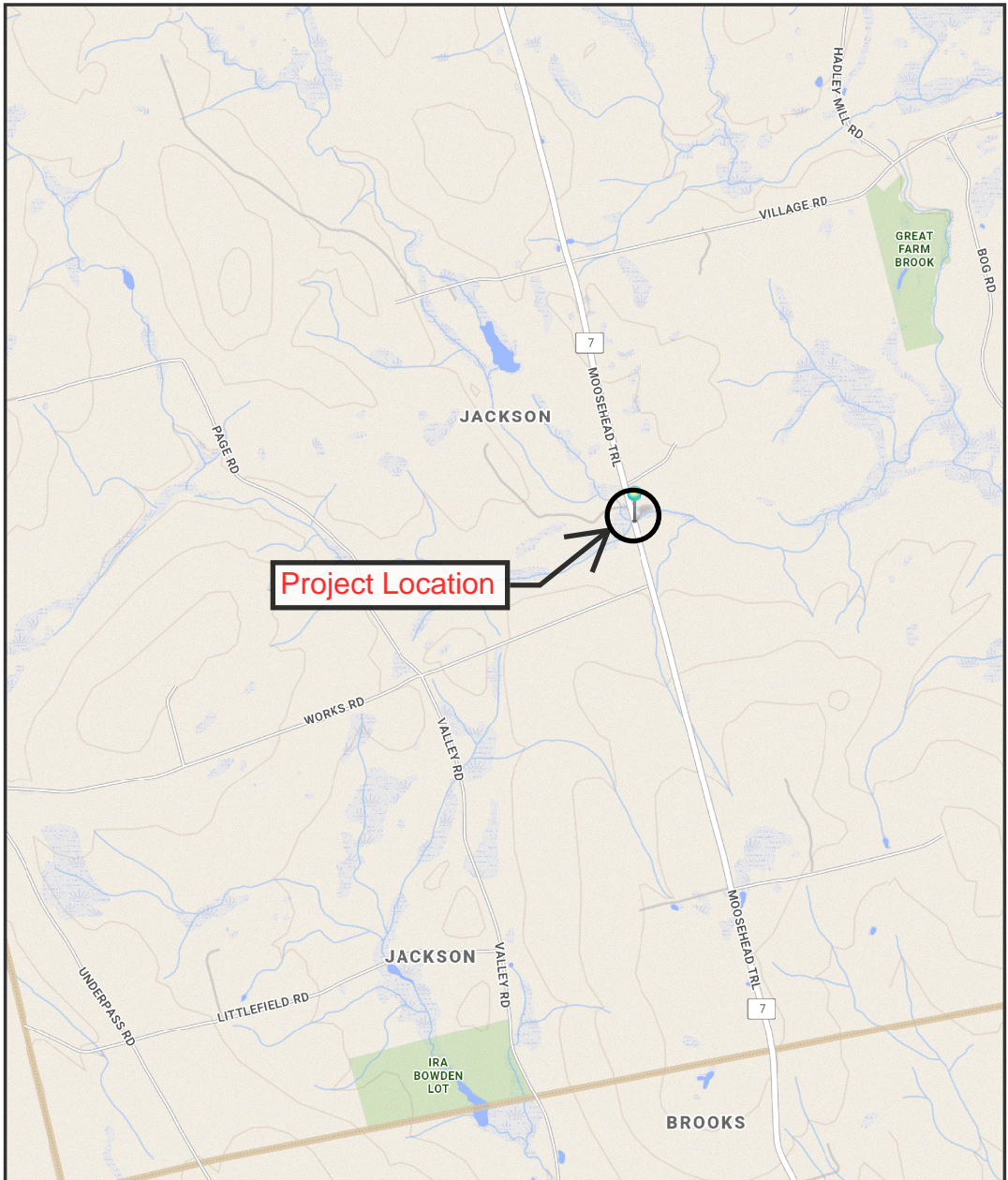

The Maine Department of Transportation provides this publication for information only. Reliance upon this information is at user risk. It is subject to revision and may be incomplete depending upon changing conditions. The Department assumes no liability if injuries or damages result from this information. This map is not intended to support emergency dispatch.

0.5 Miles
1 inch = 0.57 miles

Date: 2/11/2021
Time: 7:26:46 AM

SHEET NUMBER 1	GREAT FARM BRIDGE GREAT FARM BROOK	STATE OF MAINE DEPARTMENT OF TRANSPORTATION	
	JACKSON WALDO COUNTY	2356700	
OF 3	LOCATION MAP	WIN	23567.00
		BRIDGE NO. 3128	BRIDGE PLANS

Date: 3/16/2021

Username: Terry.White

Filename: ... \GEOTECH\MSTA\002_BLP&S\SP1.dgn Division: GEOTECH

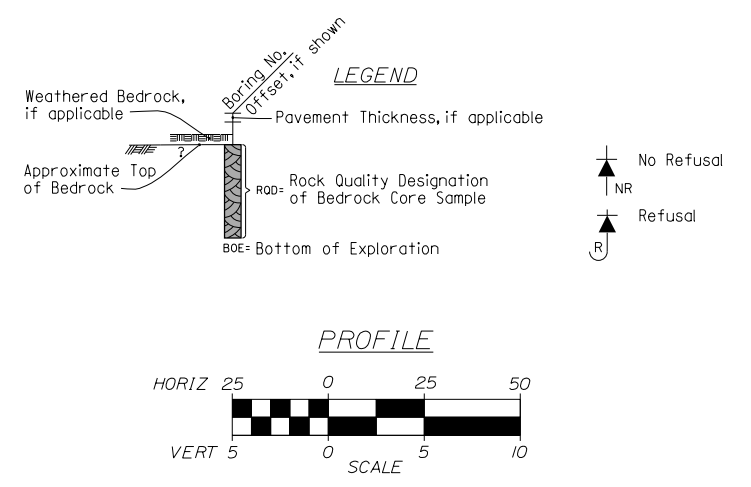
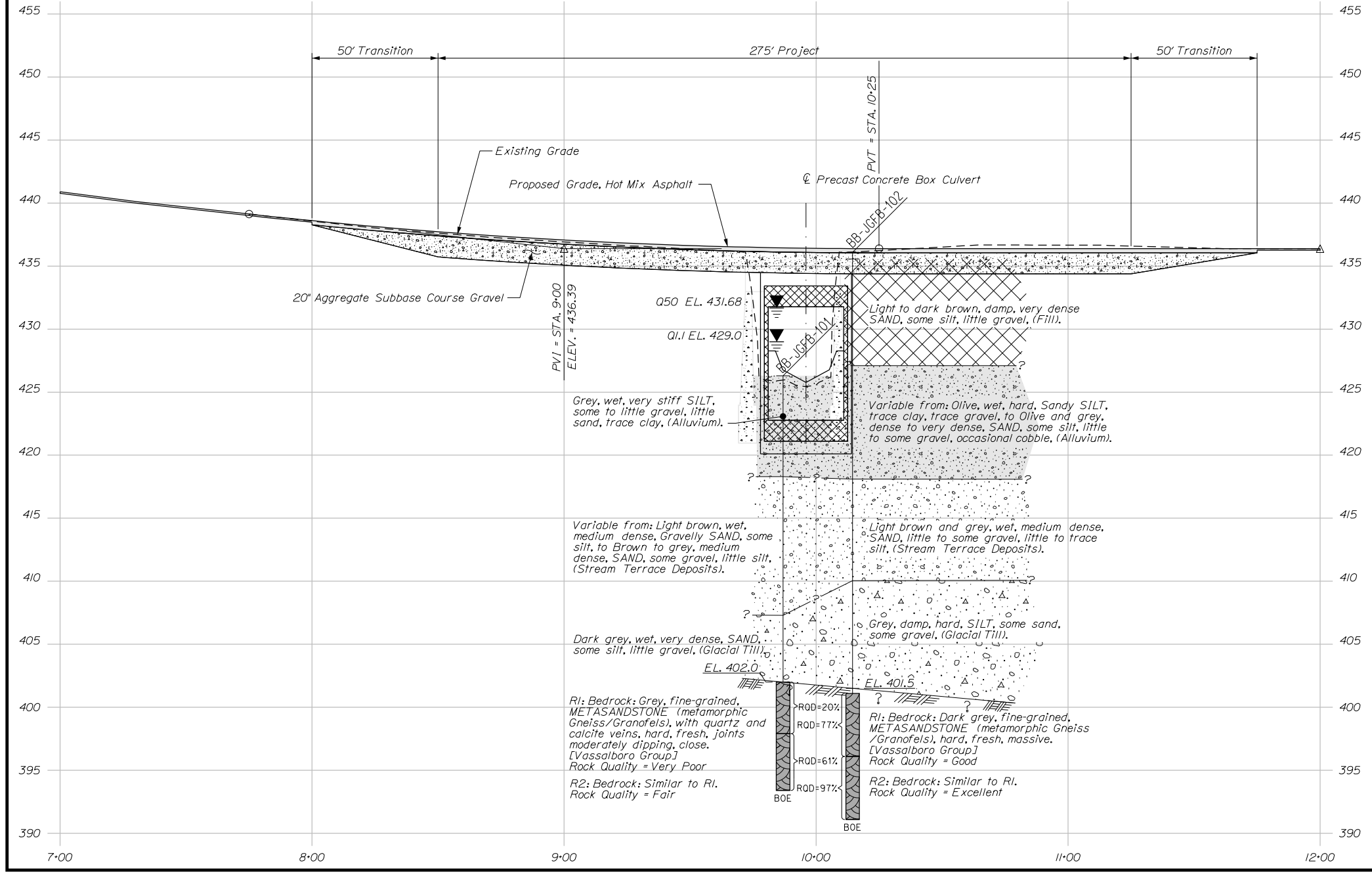
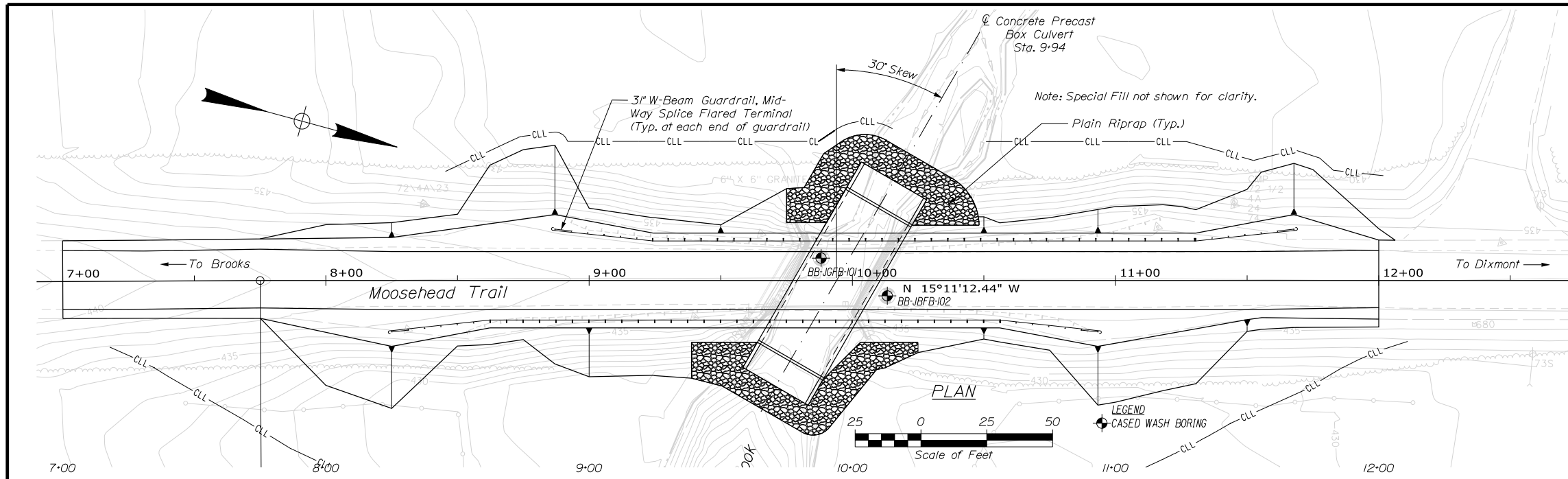

Note: This generalized interpretive soil profile is intended to convey trends in subsurface conditions. The boundaries between strata are approximate and idealized, and have been developed by interpretations of widely spaced explorations and samples. Actual soil and bedrock transitions may vary and are probably more erratic. For more specific information refer to the exploration logs.

STATE OF MAINE DEPARTMENT OF TRANSPORTATION		2356700	
GREAT FARM BRIDGE GREAT FARM BROOK WALDO COUNTY		BRIDGE NO. 3128	
JACKSON		WIN 23567.00	
BORING LOCATION PLAN & INTERPRETIVE SUBSURFACE PROFILE		BRIDGE PLANS	
PROJ. MANAGER	M. PARLIN	BY	T. WHITE
DESIGN-DETAILED	J. MANAHAN	CHECKED-REVIEWED	J. MANAHAN
DESIGNS-DETAILED		DESIGNS-DETAILED	
REVISIONS 1		REVISIONS 1	
REVISIONS 2		REVISIONS 2	
REVISIONS 3		REVISIONS 3	
REVISIONS 4		REVISIONS 4	
FIELD CHANGES		FIELD CHANGES	
DATE	JUN 2020	SIGNATURE	
		P.E. NUMBER	
		DATE	
SHEET NUMBER		2	
		OF 3	

Maine Department of Transportation Soil/Book Exploration Log US CUSTOMER UNITS		Project: Great Farm Bridge #102 carries State Route 7 over Great Farm Location: Jackson, Maine		Boring No.: BB-JGFB-101					
Driller: S.W. Cole		Elevation (ft.): 426.1		Auger ID/OD: 5" Solid Stem					
Operator: Kevin Ryan		Datum: NAVD83		Sampler: Standard Split Spoon					
Logged By: J. Manahan		Rig Type: Dierich 050		Hammer Wt./Fall: 140#/30"					
Date Started/Inch: 6/2/2020; 07:30-12:30		Drilling Method: Cased Wash Boring		Core Barrel: NO-2"					
Boring Location: 9489.1, 8.6 Ft. Lt.		Casing ID/OD: HW-4"		Water Level: Water Boring					
Hammer Efficiency Factor: 0.977 Hammer Type: Automatic <input checked="" type="checkbox"/> Hydraulic <input type="checkbox"/> Rope & Cathead <input type="checkbox"/> Penetration: 8 = Blow Count (blows/ft) 9 = Field-measured fines blow count (blows/ft) 10 = Pocket Penetration (blows/ft) 11 = Blow Count (blows/ft) 12 = Blow Count (blows/ft) 13 = Blow Count (blows/ft) 14 = Blow Count (blows/ft) 15 = Blow Count (blows/ft) 16 = Blow Count (blows/ft) 17 = Blow Count (blows/ft) 18 = Blow Count (blows/ft) 19 = Blow Count (blows/ft) 20 = Blow Count (blows/ft) 21 = Blow Count (blows/ft) 22 = Blow Count (blows/ft) 23 = Blow Count (blows/ft) 24 = Blow Count (blows/ft) 25 = Blow Count (blows/ft) 26 = Blow Count (blows/ft) 27 = Blow Count (blows/ft) 28 = Blow Count (blows/ft) 29 = Blow Count (blows/ft) 30 = Blow Count (blows/ft) 31 = Blow Count (blows/ft) 32 = Blow Count (blows/ft) 33 = Blow Count (blows/ft) 34 = Blow Count (blows/ft) 35 = Blow Count (blows/ft) 36 = Blow Count (blows/ft) 37 = Blow Count (blows/ft) 38 = Blow Count (blows/ft) 39 = Blow Count (blows/ft) 40 = Blow Count (blows/ft) 41 = Blow Count (blows/ft) 42 = Blow Count (blows/ft) 43 = Blow Count (blows/ft) 44 = Blow Count (blows/ft) 45 = Blow Count (blows/ft) 46 = Blow Count (blows/ft) 47 = Blow Count (blows/ft) 48 = Blow Count (blows/ft) 49 = Blow Count (blows/ft) 50 = Blow Count (blows/ft) 51 = Blow Count (blows/ft) 52 = Blow Count (blows/ft) 53 = Blow Count (blows/ft) 54 = Blow Count (blows/ft) 55 = Blow Count (blows/ft) 56 = Blow Count (blows/ft) 57 = Blow Count (blows/ft) 58 = Blow Count (blows/ft) 59 = Blow Count (blows/ft) 60 = Blow Count (blows/ft) 61 = Blow Count (blows/ft) 62 = Blow Count (blows/ft) 63 = Blow Count (blows/ft) 64 = Blow Count (blows/ft) 65 = Blow Count (blows/ft) 66 = Blow Count (blows/ft) 67 = Blow Count (blows/ft) 68 = Blow Count (blows/ft) 69 = Blow Count (blows/ft) 70 = Blow Count (blows/ft) 71 = Blow Count (blows/ft) 72 = Blow Count (blows/ft) 73 = Blow Count (blows/ft) 74 = Blow Count (blows/ft) 75 = Blow Count (blows/ft) 76 = Blow Count (blows/ft) 77 = Blow Count (blows/ft) 78 = Blow Count (blows/ft) 79 = Blow Count (blows/ft) 80 = Blow Count (blows/ft) 81 = Blow Count (blows/ft) 82 = Blow Count (blows/ft) 83 = Blow Count (blows/ft) 84 = Blow Count (blows/ft) 85 = Blow Count (blows/ft) 86 = Blow Count (blows/ft) 87 = Blow Count (blows/ft) 88 = Blow Count (blows/ft) 89 = Blow Count (blows/ft) 90 = Blow Count (blows/ft) 91 = Blow Count (blows/ft) 92 = Blow Count (blows/ft) 93 = Blow Count (blows/ft) 94 = Blow Count (blows/ft) 95 = Blow Count (blows/ft) 96 = Blow Count (blows/ft) 97 = Blow Count (blows/ft) 98 = Blow Count (blows/ft) 99 = Blow Count (blows/ft) 100 = Blow Count (blows/ft)									
Depth (ft.)	Sample No.	Pen./Blow (ft.)	Sample Depth (ft.)	Blow Count (blows/ft)	Visual Description and Remarks	Laboratory Testing Results/ASTM and Unified Class			
4	10	24/5	6.00 - 2.00	9/7/8/4	15	24	13	Grey, wet, very stiff, fine sandy SILT, little gravel. (Alluvium)	
5	20	24/18	8.00 - 6.00	4/4/7/13	11	18	46	Grey, wet, very stiff, SILT, some gravel, little sand, trace clay, (Alluvium)	GS40744 A-4, CL MC=13.3% Non-Plastic
10	30	24/11	9.00 - 11.00	8/10/6/4	16	26	31	Light brown, wet, medium dense, Gravely SAND, some silt, (Stream Terrace Deposits)	GS40749 A-1-2, SM MC=9.4%
15	40	24/15	14.00 - 16.00	6/6/8/6	14	23	34	Brown to grey, wet, medium dense, SAND, some gravel, little silt.	GS40745 A-1-2, SM MC=11.7%
20	50	24/13	18.00 - 21.00	35/42/16/20	58	94	94	Dark grey, wet, very dense, SAND, some silt, little gravel, (Glacial Till)	GS40746 A-2-4, SM MC=11.4%
25	60	54/51	24.20 - 24.30 24.30 - 28.40	52(1.2), RBD = 61%				Failed sample attempt.	
25	60	54/51	24.20 - 24.30 24.30 - 28.40	52(1.2), RBD = 61%				Top of Bedrock at Elev. 401.8 ft. R1: Bedrock: Grey, fine-grained, METASANDSTONE (metamorphic Gneiss/Granofels) with quartz and calcite veins, beds, fresh, joints moderately dipping, close. (Vassalboro Group) Rock Quality = Very Poor R1 Core Times (min:sec) 24.2-25.3 ft (2180) 25.3-26.3 ft (3109) 26.3-27.2 ft (3522) 27.2-28.2 ft (3513) 28.2-28.4 ft (1116) R2: Bedrock: Similar to R1 Rock Quality = Fair R2 Core Times (min:sec) 28.4-29.4 ft (8110) 29.4-30.4 ft (6309) 30.4-31.4 ft (6852) 31.4-32.4 ft (4227) 32.4-32.9 ft (3300) 3% Recovery	
30	70							Bottom of Exploration at 32.9 feet below ground surface.	
35									
40									
45									
50									
Remarks: Bridge Deck (10" Concrete) to Ground 10.8 ft. Hammer Serial Number 367.									
Stratification lines represent approximate boundaries between soil types. Transitions may be gradual.						Page 1 of 1			
* Water level readings have been made at times and under conditions stated. Groundwater fluctuations may occur due to conditions other than those present at the time measurements were made.						Boring No.: BB-JGFB-101			

Maine Department of Transportation Soil/Book Exploration Log US CUSTOMER UNITS		Project: Great Farm Bridge #102 carries State Route 7 over Great Farm Location: Jackson, Maine		Boring No.: BB-JGFB-102					
Driller: S.W. Cole		Elevation (ft.): 426.1		Auger ID/OD: 5" Solid Stem					
Operator: Kevin Ryan		Datum: NAVD83		Sampler: Standard Split Spoon					
Logged By: J. Manahan		Rig Type: Dierich 050		Hammer Wt./Fall: 140#/30"					
Date Started/Inch: 6/1/2020; 07:30-11:00		Drilling Method: Cased Wash Boring		Core Barrel: NO-2"					
Boring Location: 10413.4, 3.8 Ft. Rt.		Casing ID/OD: HW-4"		Water Level: 8.4 ft bgs.					
Hammer Efficiency Factor: 0.977 Hammer Type: Automatic <input checked="" type="checkbox"/> Hydraulic <input type="checkbox"/> Rope & Cathead <input type="checkbox"/> Penetration: 8 = Blow Count (blows/ft) 9 = Field-measured fines blow count (blows/ft) 10 = Pocket Penetration (blows/ft) 11 = Blow Count (blows/ft) 12 = Blow Count (blows/ft) 13 = Blow Count (blows/ft) 14 = Blow Count (blows/ft) 15 = Blow Count (blows/ft) 16 = Blow Count (blows/ft) 17 = Blow Count (blows/ft) 18 = Blow Count (blows/ft) 19 = Blow Count (blows/ft) 20 = Blow Count (blows/ft) 21 = Blow Count (blows/ft) 22 = Blow Count (blows/ft) 23 = Blow Count (blows/ft) 24 = Blow Count (blows/ft) 25 = Blow Count (blows/ft) 26 = Blow Count (blows/ft) 27 = Blow Count (blows/ft) 28 = Blow Count (blows/ft) 29 = Blow Count (blows/ft) 30 = Blow Count (blows/ft) 31 = Blow Count (blows/ft) 32 = Blow Count (blows/ft) 33 = Blow Count (blows/ft) 34 = Blow Count (blows/ft) 35 = Blow Count (blows/ft) 36 = Blow Count (blows/ft) 37 = Blow Count (blows/ft) 38 = Blow Count (blows/ft) 39 = Blow Count (blows/ft) 40 = Blow Count (blows/ft) 41 = Blow Count (blows/ft) 42 = Blow Count (blows/ft) 43 = Blow Count (blows/ft) 44 = Blow Count (blows/ft) 45 = Blow Count (blows/ft) 46 = Blow Count (blows/ft) 47 = Blow Count (blows/ft) 48 = Blow Count (blows/ft) 49 = Blow Count (blows/ft) 50 = Blow Count (blows/ft) 51 = Blow Count (blows/ft) 52 = Blow Count (blows/ft) 53 = Blow Count (blows/ft) 54 = Blow Count (blows/ft) 55 = Blow Count (blows/ft) 56 = Blow Count (blows/ft) 57 = Blow Count (blows/ft) 58 = Blow Count (blows/ft) 59 = Blow Count (blows/ft) 60 = Blow Count (blows/ft) 61 = Blow Count (blows/ft) 62 = Blow Count (blows/ft) 63 = Blow Count (blows/ft) 64 = Blow Count (blows/ft) 65 = Blow Count (blows/ft) 66 = Blow Count (blows/ft) 67 = Blow Count (blows/ft) 68 = Blow Count (blows/ft) 69 = Blow Count (blows/ft) 70 = Blow Count (blows/ft) 71 = Blow Count (blows/ft) 72 = Blow Count (blows/ft) 73 = Blow Count (blows/ft) 74 = Blow Count (blows/ft) 75 = Blow Count (blows/ft) 76 = Blow Count (blows/ft) 77 = Blow Count (blows/ft) 78 = Blow Count (blows/ft) 79 = Blow Count (blows/ft) 80 = Blow Count (blows/ft) 81 = Blow Count (blows/ft) 82 = Blow Count (blows/ft) 83 = Blow Count (blows/ft) 84 = Blow Count (blows/ft) 85 = Blow Count (blows/ft) 86 = Blow Count (blows/ft) 87 = Blow Count (blows/ft) 88 = Blow Count (blows/ft) 89 = Blow Count (blows/ft) 90 = Blow Count (blows/ft) 91 = Blow Count (blows/ft) 92 = Blow Count (blows/ft) 93 = Blow Count (blows/ft) 94 = Blow Count (blows/ft) 95 = Blow Count (blows/ft) 96 = Blow Count (blows/ft) 97 = Blow Count (blows/ft) 98 = Blow Count (blows/ft) 99 = Blow Count (blows/ft) 100 = Blow Count (blows/ft)									
Depth (ft.)	Sample No.	Pen./Blow (ft.)	Sample Depth (ft.)	Blow Count (blows/ft)	Visual Description and Remarks	Laboratory Testing Results/ASTM and Unified Class			
4	10	12/10	5.00 - 6.00	6/66	---	---	584	Light to dark brown, comp. very dense, SAND, some silt, little gravel. (Till)	
10	20/A	24/17	10.00 - 12.00	2/11/24/15	35	57	35	20 (10.0-11.0 ft bgs) Olive, wet, hard, fine to medium sand, SILT, trace clay, trace gravel, (Alluvium) 20/A (11.0-12.0 ft bgs) Olive, wet, very dense, SAND, some gravel, occasional cobble, (Alluvium)	GS40747 A-4, CL MC=6.1% Non-Plastic
15	30	24/15	16.00 - 17.00	14/9/12/15	21	34	34	Grey, wet, dense, SAND, some silt, little gravel, (Alluvium)	
20	40	24/12	20.00 - 22.00	8/6/5/4	11	18	46	Light brown, wet, medium dense, coarse SAND, little gravel, (Stream Terrace Deposits)	
25	50	24/13	25.00 - 27.00	8/8/9/14	17	28	52	Grey, wet, medium dense, fine to coarse SAND, some gravel, little silt (Stream Terrace Deposits).	
30	60	24/18	30.00 - 32.00	20/36/35/42	71	116	158	Grey, damp, hard SILT, some sand, some gravel (Glacial Till).	GS40748 A-4, SM MC=11.4%
35	R1	60/58	35.00 - 40.00	RBD = 71%				Top of Bedrock at Elev. 401.5 ft. Roller Corod ahead to 35.0 ft bgs. R1: Bedrock: Dark grey, fine-grained, METASANDSTONE (metamorphic Gneiss/Granofels) with quartz and calcite veins, beds, fresh, joints moderately dipping, close. (Vassalboro Group) Rock Quality = Good R1 Core Times (min:sec) 35.0-36.0 ft (2155) 36.0-37.0 ft (1309) 37.0-38.0 ft (1300) 38.0-39.0 ft (1340) 39.0-40.0 ft (1335) 3% Recovery R2: Bedrock: Similar to R1 Rock Quality = Excellent R2 Core Times (min:sec) 40.0-41.0 ft (1158) 41.0-42.0 ft (2128) 42.0-43.0 ft (1323) 43.0-44.0 ft (1359) 44.0-45.0 ft (4125) 3% Recovery	
40	R2	60/58	40.00 - 45.00	RBD = 91%				Bottom of Exploration at 45.0 feet below ground surface.	
45									
50									
Remarks: Hammer Serial Number 367.									
Stratification lines represent approximate boundaries between soil types. Transitions may be gradual.						Page 1 of 1			
* Water level readings have been made at times and under conditions stated. Groundwater fluctuations may occur due to conditions other than those present at the time measurements were made.						Boring No.: BB-JGFB-102			

STATE OF MAINE DEPARTMENT OF TRANSPORTATION 2356700		BRIDGE NO. 3128		BRIDGE PLANS	
GREAT FARM BRIDGE GREAT FARM BROOK WALDO COUNTY JACKSON		BORING LOGS		SHEET NUMBER 3 OF 3	
PROJ. MANAGER	M. PARLIN	BY	T. WHITE	DATE	MAR 2021
DESIGN-DETAILED	J. MANAHAN	CHECKED-REVIEWED		SIGNATURE	
DESIGNS-DETAILED		DESIGNS-DETAILED		P.E. NUMBER	
REVISIONS 1		REVISIONS 2		DATE	
REVISIONS 3		REVISIONS 4		FIELD CHANGES	

Appendix A

Boring Logs

UNIFIED SOIL CLASSIFICATION SYSTEM				MODIFIED BURMISTER SYSTEM	
MAJOR DIVISIONS		GROUP SYMBOLS	TYPICAL NAMES		
COARSE-GRAINED SOILS (more than half of material is larger than No. 200 sieve size)	GRAVELS (more than half of coarse fraction is larger than No. 4 sieve size)	CLEAN GRAVELS	GW	Well-graded gravels, gravel-sand mixtures, little or no fines.	
		(little or no fines)	GP	Poorly-graded gravels, gravel sand mixtures, little or no fines.	
		GRAVEL WITH FINES (Appreciable amount of fines)	GM	Silty gravels, gravel-sand-silt mixtures.	
	SANDS (more than half of coarse fraction is smaller than No. 4 sieve size)	CLEAN SANDS	SW	Well-graded sands, Gravelly sands, little or no fines	
		(little or no fines)	SP	Poorly-graded sands, Gravelly sand, little or no fines.	
		SANDS WITH FINES (Appreciable amount of fines)	SM	Silty sands, sand-silt mixtures	
FINE-GRAINED SOILS (more than half of material is smaller than No. 200 sieve size)	SILTS AND CLAYS (liquid limit less than 50)	ML	Inorganic silts and very fine sands, rock flour, Silty or Clayey fine sands, or Clayey silts with slight plasticity.		
		CL	Inorganic clays of low to medium plasticity, Gravelly clays, Sandy clays, Silty clays, lean clays.		
		OL	Organic silts and organic Silty clays of low plasticity.		
	SILTS AND CLAYS (liquid limit greater than 50)	MH	Inorganic silts, micaceous or diatomaceous fine Sandy or Silty soils, elastic silts.		
		CH	Inorganic clays of high plasticity, fat clays.		
		OH	Organic clays of medium to high plasticity, organic silts.		
HIGHLY ORGANIC SOILS	Pt	Peat and other highly organic soils.			
Desired Soil Observations (in this order, if applicable):				Desired Rock Observations (in this order, if applicable):	
Color (Munsell color chart) Moisture (dry, damp, moist, wet) Density/Consistency (from above right hand side) Texture (fine, medium, coarse, etc.) Name (Sand, Silty Sand, Clay, etc., including portions - trace, little, etc.) Gradation (well-graded, poorly-graded, uniform, etc.) Plasticity (non-plastic, slightly plastic, moderately plastic, highly plastic) Structure (layering, fractures, cracks, etc.) Bonding (well, moderately, loosely, etc.,) Cementation (weak, moderate, or strong) Geologic Origin (till, marine clay, alluvium, etc.) Groundwater level				Color (Munsell color chart) Texture (aphanitic, fine-grained, etc.) Rock Type (granite, schist, sandstone, etc.) Hardness (very hard, hard, mod. hard, etc.) Weathering (fresh, very slight, slight, moderate, mod. severe, severe, etc.) Geologic discontinuities/jointing: -dip (horiz - 0-5 deg., low angle - 5-35 deg., mod. dipping - 35-55 deg., steep - 55-85 deg., vertical - 85-90 deg.) -spacing (very close - <2 inch, close - 2-12 inch, mod. close - 1-3 feet, wide - 3-10 feet, very wide >10 feet) -tightness (tight, open, or healed) -infilling (grain size, color, etc.) Formation (Waterville, Ellsworth, Cape Elizabeth, etc.) RQD and correlation to rock quality (very poor, poor, etc.) ref: ASTM D6032 and FHWA NHI-16-072 GEC 5 - Geotechnical Site Characterization, Table 4-12 Recovery (inch/inch and percentage) Rock Core Rate (X.X ft - Y.Y ft (min:sec))	
Maine Department of Transportation Geotechnical Section Key to Soil and Rock Descriptions and Terms Field Identification Information				Sample Container Labeling Requirements: WIN Blow Counts Bridge Name / Town Sample Recovery Boring Number Date Sample Number Personnel Initials Sample Depth	

Maine Department of Transportation Soil/Rock Exploration Log US CUSTOMARY UNITS	Project: Great Farm Bridge #3128 carries State Route 7 over Great Farm Brook Location: Jackson, Maine	Boring No.: BB-JGFB-101 WIN: 23567.00
--	--	--

Driller: S.W. Cole	Elevation (ft.): 426.3	Auger ID/OD: 5" Solid Stem
Operator: Kevin/Ryan	Datum: NAVD88	Sampler: Standard Split Spoon
Logged By: J. Manahan	Rig Type: Diedrich D50	Hammer Wt./Fall: 140#/30"
Date Start/Finish: 6/2/2020; 07:30-12:30	Drilling Method: Cased Wash Boring	Core Barrel: NQ-2"
Boring Location: 9+86.9, 9.1 ft Lt.	Casing ID/OD: HW-4"	Water Level*: Water Boring

Hammer Efficiency Factor: 0.977	Hammer Type: Automatic <input checked="" type="checkbox"/> Hydraulic <input type="checkbox"/> Rope & Cathead <input type="checkbox"/>
--	--

Definitions: R = Rock Core Sample S_U = Peak/Remolded Field Vane Undrained Shear Strength (psf) T_v = Pocket Torvane Shear Strength (psf)
 D = Split Spoon Sample SSA = Solid Stem Auger S_{U(lab)} = Lab Vane Undrained Shear Strength (psf) WC = Water Content, percent
 MD = Unsuccessful Split Spoon Sample Attempt HSA = Hollow Stem Auger q_p = Unconfined Compressive Strength (ksf) LL = Liquid Limit
 U = Thin Wall Tube Sample RC = Roller Cone N-uncorrected = Raw Field SPT N-value PL = Plastic Limit
 MU = Unsuccessful Thin Wall Tube Sample Attempt WOH = Weight of 140lb. Hammer Hammer Efficiency Factor = Rig Specific Annual Calibration Value PI = Plasticity Index
 V = Field Vane Shear Test, PP = Pocket Penetrometer WOR/C = Weight of Rods or Casing N₆₀ = SPT N-uncorrected Corrected for Hammer Efficiency G = Grain Size Analysis
 MV = Unsuccessful Field Vane Shear Test Attempt WO1P = Weight of One Person N₆₀ = (Hammer Efficiency Factor/60%)*N-uncorrected C = Consolidation Test

Depth (ft.)	Sample Information								Elevation (ft.)	Graphic Log	Visual Description and Remarks	Laboratory Testing Results/AASHTO and Unified Class.
	Sample No.	Pen./Rec. (in.)	Sample Depth (ft.)	Blows (6 in.) Shear Strength (psf) or RQD (%)	N-uncorrected	N ₆₀	Casing Blows					
0	1D	24/5	0.00 - 2.00	9/7/8/4	15	24	13		418.3	Grey, wet, very stiff, fine Sandy SILT, little gravel. (Alluvium)	G#340744 A-4, CL WC=13.3% Non-Plastic	
							33					
							35					
							34					
5	2D	24/18	4.00 - 6.00	4/4/7/13	11	18	46		418.3	Grey, wet, very stiff, SILT, some gravel, little sand, trace clay. (Alluvium)	G#340749 A-1-b, SM WC=9.4%	
							102					
							143					
							172					
10	3D	24/11	9.00 - 11.00	8/10/6/4	16	26	31		418.3	Light brown, wet, medium dense, Gravelly SAND, some silt. (Stream Terrace Deposits)	G#340749 A-1-b, SM WC=9.4%	
							63					
							51					
							39					
15	4D	24/15	14.00 - 16.00	6/6/8/6	14	23	34		418.3	Brown to grey, wet, medium dense, SAND, some gravel, little silt.	G#340745 A-1-b, SW-SM WC=13.7%	
							43					
							97					
							103					
20	5D	24/13	19.00 - 21.00	33/42/16/20	58	94	OPEN HOLE		407.3	Dark grey, wet, very dense, SAND, some silt, little gravel, (Glacial Till).	G#340746 A-2-4, SM WC=11.6%	
							46					
25	MD	1.2/0	24.20 - 24.30	52(1.2")	---		NQ-2		402.0	Failed sample attempt.		

Remarks:
 Bridge Deck (10" Concrete) to Ground 10.8 ft.
 Hammer Serial Number 367.

Maine Department of Transportation Soil/Rock Exploration Log US CUSTOMARY UNITS	Project: Great Farm Bridge #3128 carries State Route 7 over Great Farm Brook Location: Jackson, Maine	Boring No.: <u>BB-JGFB-102</u> WIN: <u>23567.00</u>
--	--	--

Driller: S.W. Cole	Elevation (ft.): 436.1	Auger ID/OD: 5" Solid Stem
Operator: Kevin/Ryan	Datum: NAVD88	Sampler: Standard Split Spoon
Logged By: J. Manahan	Rig Type: Diedrich D50	Hammer Wt./Fall: 140#/30"
Date Start/Finish: 6/1/2020; 07:30-13:00	Drilling Method: Cased Wash Boring	Core Barrel: NQ-2"
Boring Location: 10+14.5, 5.4 ft Rt.	Casing ID/OD: HW-4"	Water Level*: 8.4 ft bgs.
Hammer Efficiency Factor: 0.977	Hammer Type: Automatic <input checked="" type="checkbox"/> Hydraulic <input type="checkbox"/> Rope & Cathead <input type="checkbox"/>	

Definitions: R = Rock Core Sample S_U = Peak/Remolded Field Vane Undrained Shear Strength (psf) T_v = Pocket Torvane Shear Strength (psf)
D = Split Spoon Sample SSA = Solid Stem Auger S_{U(lab)} = Lab Vane Undrained Shear Strength (psf) WC = Water Content, percent
MD = Unsuccessful Split Spoon Sample Attempt HSA = Hollow Stem Auger q_p = Unconfined Compressive Strength (ksf) LL = Liquid Limit
U = Thin Wall Tube Sample RC = Roller Cone N-uncorrected = Raw Field SPT N-value PL = Plastic Limit
MU = Unsuccessful Thin Wall Tube Sample Attempt WOH = Weight of 140lb. Hammer Hammer Efficiency Factor = Rig Specific Annual Calibration Value PI = Plasticity Index
V = Field Vane Shear Test, PP = Pocket Penetrometer WOR/C = Weight of Rods or Casing N₆₀ = SPT N-uncorrected Corrected for Hammer Efficiency G = Grain Size Analysis
MV = Unsuccessful Field Vane Shear Test Attempt WO1P = Weight of One Person N₆₀ = (Hammer Efficiency Factor/60%)*N-uncorrected C = Consolidation Test

Depth (ft.)	Sample Information								Elevation (ft.)	Graphic Log	Visual Description and Remarks	Laboratory Testing Results/AASHTO and Unified Class.
	Sample No.	Pen./Rec. (in.)	Sample Depth (ft.)	Blows (6 in.) Shear Strength (psf) or RQD (%)	N-uncorrected	N ₆₀	Casing Blows					
0								SSA	435.6	6 1/2" HMA.		
5	1D	12/10	5.00 - 6.00	6/66	---					Light to dark brown, damp, very dense, SAND, some silt, little gravel. (Fill)		
10	2D/A	24/17	10.00 - 12.00	2/11/24/15	35	57	55		427.1	2D (10.0-11.0 ft bgs) Olive, wet, hard, fine to medium Sandy SILT, trace clay, trace gravel. (Alluvium) 2D/A (11.0-12.0 ft bgs) Olive, wet, very dense, SAND, some gravel, occasional cobble. (Alluvium)	G#340747 A-4, CL WC=46.1% Non-Plastic	
15	3D	24/13	15.00 - 17.00	14/9/12/15	21	34	34			Grey, wet, dense, SAND, some silt, little gravel. (Alluvium)		
20	4D	24/12	20.00 - 22.00	8/6/5/4	11	18	46		418.1	Roller Coned ahead from 18.0-20.0 ft bgs. Light brown, wet, medium dense, coarse SAND, little gravel. (Stream Terrace Deposits)		
25							46					

Remarks:
Hammer Serial Number 367.

Maine Department of Transportation Soil/Rock Exploration Log US CUSTOMARY UNITS				Project: Great Farm Bridge #3128 carries State Route 7 over Great Farm Brook Location: Jackson, Maine				Boring No.: BB-JGFB-102				
Driller: S.W. Cole				Elevation (ft.): 436.1				Auger ID/OD: 5" Solid Stem				
Operator: Kevin/Ryan				Datum: NAVD88				Sampler: Standard Split Spoon				
Logged By: J. Manahan				Rig Type: Diedrich D50				Hammer Wt./Fall: 140#/30"				
Date Start/Finish: 6/1/2020; 07:30-13:00				Drilling Method: Cased Wash Boring				Core Barrel: NQ-2"				
Boring Location: 10+14.5, 5.4 ft Rt.				Casing ID/OD: HW-4"				Water Level*: 8.4 ft bgs.				
Hammer Efficiency Factor: 0.977				Hammer Type: Automatic <input checked="" type="checkbox"/> Hydraulic <input type="checkbox"/> Rope & Cathead <input type="checkbox"/>								
Definitions: D = Split Spoon Sample MD = Unsuccessful Split Spoon Sample Attempt U = Thin Wall Tube Sample MU = Unsuccessful Thin Wall Tube Sample Attempt V = Field Vane Shear Test, PP = Pocket Penetrometer MV = Unsuccessful Field Vane Shear Test Attempt				R = Rock Core Sample SSA = Solid Stem Auger HSA = Hollow Stem Auger RC = Roller Cone WOH = Weight of 140 lb. Hammer WOR/C = Weight of Rods or Casing WO1P = Weight of One Person				S _u = Peak/Remolded Field Vane Undrained Shear Strength (psf) S _{u(lab)} = Lab Vane Undrained Shear Strength (psf) q _p = Unconfined Compressive Strength (ksf) N-uncorrected = Raw Field SPT N-value Hammer Efficiency Factor = Rig Specific Annual Calibration Value N ₆₀ = SPT N-uncorrected Corrected for Hammer Efficiency N ₆₀ = (Hammer Efficiency Factor/60%)*N-uncorrected		T _v = Pocket Torvane Shear Strength (psf) WC = Water Content, percent LL = Liquid Limit PL = Plastic Limit PI = Plasticity Index G = Grain Size Analysis C = Consolidation Test		
Depth (ft.)	Sample Information								Elevation (ft.)	Graphic Log	Visual Description and Remarks	Laboratory Testing Results/AASHTO and Unified Class.
	Sample No.	Pen./Rec. (in.)	Sample Depth (ft.)	Blows (6 in.) Shear Strength (psf) or RQD (%)	N-uncorrected	N ₆₀	Casing Blows					
25	5D	24/13	25.00 - 27.00	8/8/9/14	17	28	52	410.1		Grey, wet, medium dense, fine to coarse SAND, some gravel, little silt (Stream Terrace Deposits).		
30	6D	24/18	30.00 - 32.00	20/36/35/42	71	116	OPEN HOLE			Grey, damp, hard SILT, some sand, some gravel (Glacial Till).	G#340748 A-4, SM WC=11.6%	
35	R1	60/58	35.00 - 40.00	RQD = 77%			NQ-2	401.5		Top of Bedrock at Elev. 401.5 ft. Roller Coned ahead to 35.0 ft bgs. R1: Bedrock: Dark grey, fine-grained, METASANDSTONE, hard, fresh, massive. [Vassalboro Group] Rock Quality = Good R1: Core Times (min:sec) 35.0-36.0 ft (2:55) 36.0-37.0 ft (3:09) 37.0-38.0 ft (3:00) 38.0-39.0 ft (3:40) 39.0-40.0 ft (3:35) 92% Recovery R2: Bedrock: Similar to R1 Rock Quality = Excellent R2: Core Times (min:sec) 40.0-41.0 ft (1:58) 41.0-42.0 ft (2:28) 42.0-43.0 ft (3:23) 43.0-44.0 ft (3:59) 44.0-45.0 ft (4:25) 97% Recovery		
40	R2	60/58	40.00 - 45.00	RQD = 97%								
45								391.1		Bottom of Exploration at 45.0 feet below ground surface.		
50												

Remarks:
Hammer Serial Number 367.

Stratification lines represent approximate boundaries between soil types; transitions may be gradual.

* Water level readings have been made at times and under conditions stated. Groundwater fluctuations may occur due to conditions other than those present at the time measurements were made.

Appendix B

Rock Core Photographs



**Great Farm Bridge #3128 Carries State Route 7 Over Great Farm Brook
Jackson, ME
Rock Core Photographs**

Boring No.	Run	Depth (ft)	Petration (in)	Recovery (in)	RQD (in)	RQD (%)	Rock Type	Box Row
BB-JGFB-102	R1	35.0-40.0	60	58	48	77	METASANDSTONE	1
BB-JGFB-102	R2	40.0-45.0	60	58	35	97	METASANDSTONE	2
BB-JGFB-101	R1	24.3-28.4	49	31	10	20	METASANDSTONE	3
BB-JGFB-101	R2	28.4-32.9	51	54	33	61	METASANDSTONE	4



Notes: 1. "Box row" indicates the section of the box where the core run is contained: 1 = top, 4 = bottom.

Appendix C

Laboratory Test Results

Maine Department of Transportation Grain Size Distribution Curve

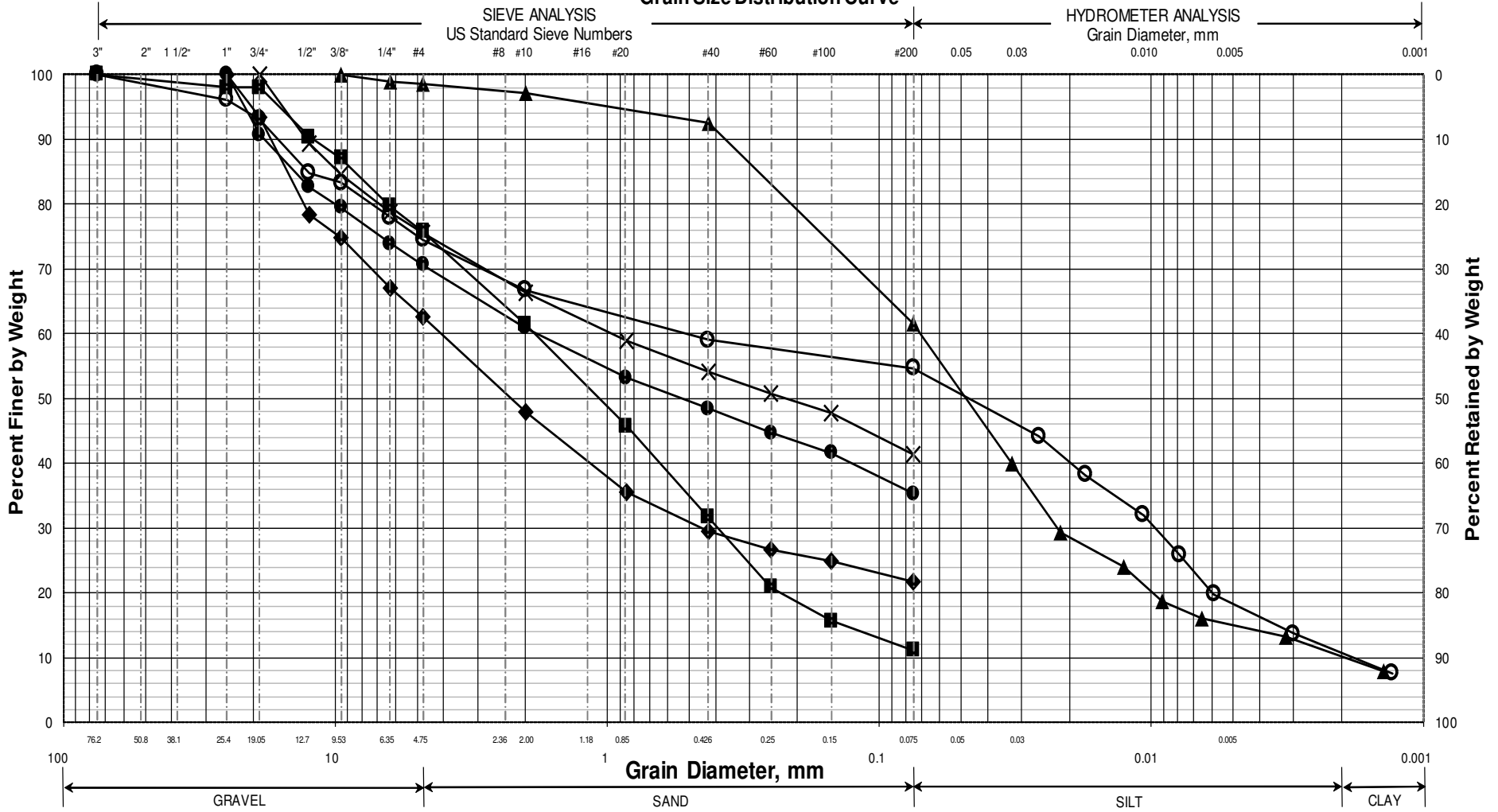

	Boring/Sample No.	Station	Offset, ft	Depth, ft	Description	WC, %	LL	PL	PI
○	BB-JGFB-101/2D	9+86.9	9.1 LT	4.0-6.0	SILT, some gravel, little sand, trace clay.	13.3			NP
◆	DB-JGFB-101/3D	9+86.9	9.1 LT	9.0-11.0	Gravelly SAND, some silt.	9.4			
■	BB-JGFB-101/4D	9+86.9	9.1 LT	14.0-16.0	SAND, some gravel, little silt.	13.7			
●	BB-JGFB-101/5D	9+86.9	9.1 LT	19.0-21.0	SAND, some silt, some gravel.	11.6			
▲	BB-JGFB-102/2D	10+14.5	5.4 RT	10.0-11.0	Sandy SILT, trace clay, trace gravel.	46.1			NP
×	BB-JGFB-102/6D	10+14.5	5.4 RT	30.0-32.0	SILT, some sand, some gravel.	11.6			

WIN
023567.00
Town
Jackson
Reported by/Date
WHITE, TERRY A 7/7/2020

Appendix D

Calculations

Earth Pressure

Earth Pressure:

Backfill engineering strength parameters

Soil Type 4 Properties from MaineDOT Bridge Design Guide (BDG)

Unit weight $\gamma := 125 \cdot \text{pcf}$

Internal friction angle $\phi := 32 \cdot \text{deg}$

Cohesion $c := 0 \cdot \text{psf}$

Outlet Walls Fixed to Box

At-Rest Earth Pressure - Rankine Theory

$$K_o := 1 - \sin(\phi)$$

$$K_o = 0.47$$

Fang, Foundation
Engineering Handbook
2nd ed. Pg. 224, Eq. 6.2
Formula for normally
consolidated soils.

Outlet walls free to rotate - Active Earth Pressure - Rankine Theory

The earth pressure is applied to a plane extending vertically up from the heel of the wall base, and the weight of the soil on the inside of the vertical plane is considered as part of the wall weight. The failure sliding surface is not restricted by the top of the wall or back face of wall.

For cantilver walls with horizontal backslope:

$$K_{ar} := \tan\left(45 \cdot \text{deg} - \frac{\phi}{2}\right)^2$$

$$K_{ar} = 0.31$$

For a sloped 2H:1V backfill

β = Angle of fill slope to the horizontal $\beta := 26.56 \cdot \text{deg}$

$$K_{ar_slope} := \cos(\beta) \frac{\cos(\beta) - \sqrt{\cos(\beta)^2 - \cos(\phi)^2}}{\cos(\beta) + \sqrt{\cos(\beta)^2 - \cos(\phi)^2}} \quad K_{ar_slope} = 0.46$$

P_a is oriented at an angle of β to the vertical plane - See MaineDOT Bridge Design Guide Figure 3-3 attached.

6.1 AT-REST LATERAL PRESSURES

At-rest pressures exist in level ground, and develop under long-term conditions as the soil is deposited and acted upon by changes in the loading environment as caused by erosion, glaciers, and physicochemical processes. At-rest pressures rigorously only apply for walls that are placed into the ground with a minimum of disturbance and that remain unmoved during loading, or for unmoving, frictionless walls with a backfill placed with a minimum of compactive effort. In practice such conditions are rarely achieved. However, at-rest pressures are still useful in design as either a baseline against which other pressure states can be judged or as an assumed conservative choice for the design loading.

At-rest effective lateral pressures are often assumed to follow a linear distribution (Fig. 6.2), with the effective lateral pressure σ'_x taken as a simple multiple of the vertical effective pressure σ'_z :

$$\sigma'_x = K_0(\sigma'_z) \tag{6.1}$$

In homogeneous, dry soil with a constant K_0 and unit weight, both the vertical and lateral pressures are linearly distributed. With the presence of a water table, the at-rest pressure distribution exhibits a break in slope at the water table, reflecting the use of submerged unit weights to determine vertical effective stresses (Fig. 6.2).

Our early concepts of the parameter K_0 were formed on the basis of normally consolidated soils. Jaky (1944) proposed a relationship between K_0 and the drained friction angle ϕ' for normally consolidated soils:

$$K_0 = 1 - \sin \phi' \tag{6.2}$$

Numerous studies have confirmed the general validity of this empirical equation (Brooker and Ireland, 1965; Mayne and Kulhawy, 1982). However, results from laboratory experiments and in-situ tests have shown that the K_0 value also varies as a function of overconsolidation ratio (OCR) and stress history. For the case of a soil that has been subjected to one or more cycles of unloading, Schmidt (1966) proposed that K_0 can be determined as a function of its value in the normally consolidated state using the relationship

$$K_{0u} = K_{0nc}(\text{OCR})^\alpha \tag{6.3}$$

in which K_{0u} is the coefficient for unloading, K_{0nc} is the coefficient for the normally consolidated soil, and α is a dimensionless coefficient. Experimental data have confirmed this relationship, and Mayne and Kulhawy (1982) showed that, for most soils, α can be taken as $\sin \phi'$.

Soils that are overconsolidated and are in the process of being reloaded pose a difficulty in that Equation 6.3 does not apply. For this condition, a more complex equation is needed as well as a full knowledge of the stress history of the soil (Mayne and Kulhawy, 1982). For practical purposes, it may

TABLE 6.1 TYPICAL COEFFICIENTS OF LATERAL EARTH PRESSURE AT REST.

Soil type	Coefficient of Lateral Earth Pressure			
	OCR = 1	OCR = 2 ^a	OCR = 5 ^a	OCR = 10 ^a
Loose sand	0.45	0.65	1.10	1.50
Medium sand	0.40	0.60	1.05	1.55
Dense sand	0.35	0.55	1.00	1.50
Silt	0.50	0.70	1.10	1.60
Lean clay, CL	0.60	0.80	1.20	1.65
Highly plastic clay, CH	0.65	0.80	1.10	1.40

^a Unloading cycle.

be enough to know that the K_0 during reloading falls about halfway between that for unloading and normally consolidated conditions. Also, K_0 might be directly determined through in-situ testing methods.

Table 6.1 presents typical values for K_0 for a subset of soils. For other conditions, K_0 values can be determined directly from Equations 6.2 and 6.3, and/or using in-situ testing techniques.

Because the K_0 value in a given soil often varies with depth, and the soil types themselves may change with depth, the at-rest lateral pressure distribution is typically not linear as shown in Figure 6.2. Self-boring pressuremeter tests in clays with overconsolidated profiles induced by desiccation have demonstrated that the K_0 under such conditions decreases with depth in the soil deposit and reaches a steady state where the desiccation effects are no longer present (Clough and Denby, 1980).

6.2 ACTIVE AND PASSIVE LATERAL EARTH PRESSURES

Most walls move, either by global shifting or by local deformations. These movements cause adjustments to occur in the earth loads and the pressure distributions. Conventional means for assessing the effects of system movements are to set them into the context of extreme conditions. These are referred to as the active and passive earth pressure loadings.

6.2.1 Active Pressure

Assuming that a gravity wall with no friction on its face is translated away from a soil mass that is initially at the at-rest condition, then the soil mass adjacent to the wall will pass into a failure state as shown in Figure 6.3. At this stage, the

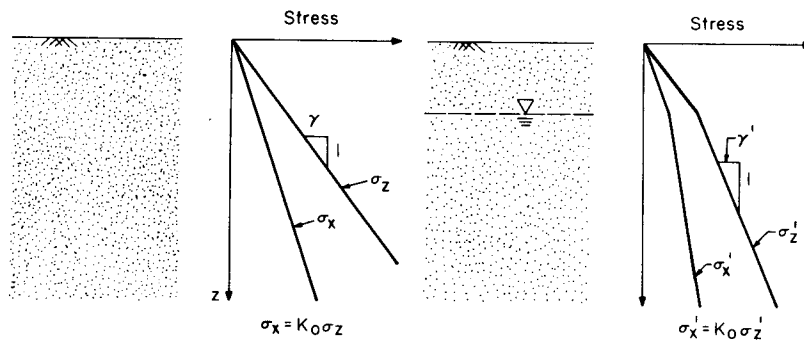

Fig. 6.2 At-rest earth pressure distribution—homogeneous soil.

Figure 3-2 Calculating β with Broken Backfill Surface

Rankine theory, as described in Section 3.6.5.2, may also be used for the design of yielding walls, for a simplified analysis (at the Structural Designer's option). The use of Rankine theory will result in a slightly more conservative design.

3.6.5.2 Rankine Theory

Rankine theory should be used for long-heeled cantilever walls. Refer to AASHTO LRFD Figure C3.11.5.3-1 (a) for the definition of a long heeled cantilever wall. For simplicity (at the Structural Designer's option), Rankine theory may also be used to compute lateral earth pressures on any yielding wall listed in 3.6.5.1 Coulomb Theory, although its use will result in a slightly more conservative design.

For these cases, interface friction between the wall backface and the backfill is not considered. Rankine earth pressure is applied to a plane extending vertically from the heel of the wall base, as shown in Figure 3-3.

For a horizontal backfill surface where $\beta = 0^\circ$, the value of the coefficient of active earth pressure (Rankine), K_a , may be taken as:

$$K_a = \tan^2 \left(45^\circ - \frac{\phi}{2} \right)$$

where:

ϕ = angle of internal soil friction (degrees), taken from Table 3-3.

β = angle of backfill to the horizontal (degrees), as shown in Figure 3-3.

For a sloped backfill surface where $\beta > 0^\circ$, the coefficient of active earth pressure (Rankine), K_a , may be taken as:

$$K_a = \cos \beta \cdot \frac{\cos \beta - \sqrt{\cos^2 \beta - \cos^2 \phi}}{\cos \beta + \sqrt{\cos^2 \beta - \cos^2 \phi}}$$

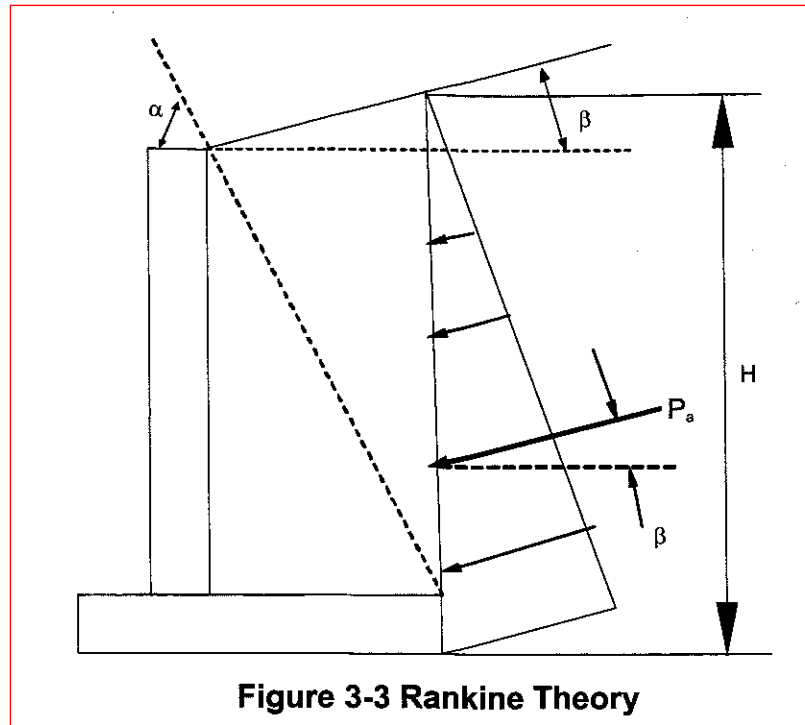

Figure 3-3 Rankine Theory

The resultant earth pressure force, P_a , is oriented at an angle, β , as shown in Figure 3-3. The resultant acts at a distance, $H/3$, from the base of the footing.

For situations with a broken backfill surface, the active earth pressure coefficient, K_a , may be determined using a β value adjusted per AASHTO LRFD Figures 3.11.5.8 -1 through 3, or substituted with β^* , as shown in Figure 3-2.

3.6.6 Coulomb Passive Lateral Earth Pressure Coefficient

Values of the coefficient of passive lateral earth pressure, K_p , may be taken from Figures 3.11.5.4-1 and 2 in AASHTO LRFD or using Coulomb theory, as shown below:

$$K_p = \frac{\sin(\alpha - \phi)^2}{\sin \alpha^2 \cdot \sin(\alpha + \delta) \cdot \left(1 - \sqrt{\frac{\sin(\phi + \delta) \cdot \sin(\phi + \beta)}{\sin(\alpha + \delta) \cdot \sin(\alpha + \beta)}} \right)^2}$$

where:

α = angle (degrees) of back of wall to the horizontal as shown in Figure 3-1.

ϕ = angle of internal soil friction (degrees), taken from Table 3-3.

Bearing Resistance

Objective:

Estimate the factored bearing resistance for a box culvert bearing on soil at the Service Limit State and Strength Limit State.

Given:

1. Limited lab data
2. Soil engineering properties based on correlations to SPT N-values

Assumptions:

1. The box culvert's embedment into the streambed is conservatively assumed as 1 foot, which accounts for the possible scouring away of 1 foot of special fill.
2. The one foot thick layer of proposed Granular Borrow bedding material modeled as subgrade.
3. The proposed bearing elevation is approximately 420 feet.
4. Proposed finish roadway grade elevation is approximately 436.5 feet at the low point.
5. Proposed precast concrete box base is 28 feet wide.
6. The bottom of the box culvert will be submerged for the structure's design life.

Estimate the factored bearing resistance at the Service Limit State:

The use of presumptive values may be used when sufficient knowledge of geological conditions at or near the structure site exists. AASHTO LRFD 8th Edition Table C10.6.2.6.1-1 provides presumptive bearing resistances for spread footings when a settlement limited bearing resistance is appropriate. For more information see *NavFac DM 7.2, May 1983, Foundations and Earth Structures*, Table 1, p. 7.2-142.

Type of Bearing Material	Consistency in Place	Bearing Resistance (ksf)	
		Ordinary Range	Recommended Value of Use
Coarse to medium sand with little gravel (SW, SP)	Medium dense to dense	4-8	6

Recommend 6 ksf to limit settlement to 1.0 inch for Service Limit State Loads

2. Estimate the factored bearing resistance at the Strength Limit State:

Foundation Width, Depth, and Water Surface

$$B := 28\text{ft}$$

$$D_f := 1.0\text{ft}$$

$$D_w := 0\text{ft}$$

$$\gamma_w := 62.4\text{pcf}$$

Total unit weight of the soil above the base slab/soil envelope

$$\gamma_{\text{above}} := 125 \cdot \text{pcf} \quad \text{MaineDOT Bridge Design Guide p. 3-3 Soil Type 4}$$

$$\gamma_{\text{above_sat}} := 135 \cdot \text{pcf}$$

Foundation soils:

Foundation soils based on BB-JGFB-102 3D

$$\gamma_{1d} := 125 \cdot \text{pcf}$$

$$w_{\text{sat}} := 13.3\% \quad \text{BB-JGFB-101 2D, N=18 BPF, fine grained}$$

$$\gamma_{1\text{sat}} := \gamma_{1d} \cdot (1 + w_{\text{sat}}) \quad \text{Das, Principles of Geotechnical Eng. 7th Ed. p. 59: Table 3.1 Unit weight relationships}$$

$$\gamma_{1\text{sat}} = 141.6 \cdot \text{pcf}$$

$$\phi := 32 \cdot \text{deg} \quad \text{AASHTO Table 10.4.6.2.4-1 and Commentary C10.4.6.2.4, Correlation of N60 Values to Drained Friction Angle of Granular Soils, interpolated for fine, medium, and coarse grained soils}$$

$$c := 0$$

Nominal Bearing Resistance for Strength Limit States

Reference: Munfakh, et al (2001) LRFD Article 10.6.3.1.2a

Bearing Capacity Factors (Ref: LRFD Table 10.6.3.1.2a-1)

$$N_c := 35.5$$

$$N_q := 23.2$$

$$N_\gamma := 30.2$$

Shape Factors - per LRFD Table 10.6.3.1.2a-3

$$L := 88 \cdot \text{ft}$$

$$s_c := 1 + \left(\frac{B}{L}\right) \cdot \left(\frac{N_q}{N_c}\right)$$

$$s_\gamma := 1 - 0.4 \cdot \left(\frac{B}{L}\right)$$

$$s_q := 1 + \frac{B}{L} \cdot \tan(\phi)$$

$$s_c = 1.2 \quad s_\gamma = 0.9 \quad s_q = 1.2$$

Groundwater Coefficients - LRFD Table 10.6.3.1.2a-2

The highest anticipated groundwater level should be used in design.

Assume groundwater, or stream elevation, will be above the invert of the structure for the entire design life.

$$C_{wq} := .5 \quad C_{w\gamma} := 0.5$$

Load Inclination factors

No knowledge of vertical and horizontal loads at this time. Use 1.0

$$i_c := 1.0 \quad i_\gamma := 1.0 \quad i_q := 1.0$$

Depth correction factors - only used when soils above the footing bearing elevation are as competent as the soils beneath the footing level. Otherwise 1.0

LRFD Table 10.6.3.1.2a-4

$$\frac{D_f}{B} = 0.04$$

Therefore :

$$d_q := 1.0$$

Terms

$$N_{cm} := N_c \cdot s_c \cdot i_c$$

$$N_{qm} := N_q \cdot s_q \cdot d_q \cdot i_q$$

$$N_{\gamma m} := N_\gamma \cdot s_\gamma \cdot i_\gamma$$

$$N_{cm} = 42.9$$

$$N_{\gamma m} = 26.4$$

$$N_{qm} = 27.8$$

Nominal Bearing Resistance (LRFD Eq 10.6.3.1.2a-1)

$$q_n := \left[c \cdot N_{cm} + \gamma_{\text{above_sat}} \cdot D_f \cdot N_{qm} \cdot C_{wq} + 0.5 \cdot \gamma_{\text{sat}} \cdot \overline{(B \cdot N_{\gamma m})} \cdot C_{w\gamma} \right]$$

$$q_n = 28 \cdot \text{ksf}$$

Factored Bearing Resistance

$$\phi_b := 0.45$$

$$q_r := q_n \cdot \phi_b$$

$$q_r = 12.6 \text{ ksf}$$

Recommend a factored bearing resistance of 12 ksf for box bottom slabs 28 ft or greater on compacted granular borrow.

3.4 Construction Loads

The construction live load to be used for constructibility checks is 50 psf applied over the entire deck area. Consideration should be given to slab placement sequence for calculation of maximum force effects.

3.5 Railroad Loads

Railroad bridges should be designed according to the latest American Railroad Engineering and Maintenance-of-Way Association specifications (AREMA, 2002), with the Cooper live loading as determined by the railroad company.

3.6 Earth Loads

3.6.1 General

Earth pressures considered for wall and substructure design must use the appropriate soil weight shown in Table 3-3.

Table 3-3 Material Classification

Soil Type	Soil Description	Internal Angle of Friction of Soil, ϕ	Soil Total Unit Weight (pcf)	Coeff. of Friction, $\tan \delta$, Concrete to Soil	Interface Friction, Angle, Concrete to Soil δ
1	Very loose to loose silty sand and gravel Very loose to loose sand Very loose to medium density sandy silt Stiff to very stiff clay or clayey silt	29°*	100	0.35	19°
2	Medium density silty sand and gravel Medium density to dense sand Dense to very dense sandy silt	33°	120	0.40	22°
3	Dense to very dense silty sand and gravel Very dense sand	36°	130	0.45	24°
4	Granular underwater backfill Granular borrow	32°	125	0.45	24°
5	Gravel Borrow	36°	135	0.50	27°

* The value given for the internal angle of friction (ϕ) for stiff to very stiff silty clay or clayey silt should be used with caution due to the large possible variation with different moisture contents.

3.4 Various Unit-Weight Relationships

In Sections 3.2 and 3.3, we derived the fundamental relationships for the moist unit weight, dry unit weight, and saturated unit weight of soil. Several other forms of relationships that can be obtained for γ , γ_d , and γ_{sat} are given in Table 3.1. Some typical values of void ratio, moisture content in a saturated condition, and dry unit weight for soils in a natural state are given in Table 3.2.

Table 3.1 Various Forms of Relationships for γ , γ_d , and γ_{sat}

Moist unit weight (γ)		Dry unit weight (γ_d)		Saturated unit weight (γ_{sat})	
Given	Relationship	Given	Relationship	Given	Relationship
w, G_s, e	$\frac{(1 + w)G_s\gamma_w}{1 + e}$	γ, w	$\frac{\gamma}{1 + w}$	G_s, e	$\frac{(G_s + e)\gamma_w}{1 + e}$
S, G_s, e	$\frac{(G_s + Se)\gamma_w}{1 + e}$	G_s, e	$\frac{G_s\gamma_w}{1 + e}$	G_s, n	$[(1 - n)G_s + n]\gamma_w$
w, G_s, S	$\frac{(1 + w)G_s\gamma_w}{1 + \frac{wG_s}{S}}$	G_s, n	$G_s\gamma_w(1 - n)$	G_s, w_{sat}	$\left(\frac{1 + w_{sat}}{1 + w_{sat}G_s}\right)G_s\gamma_w$
w, G_s, n	$G_s\gamma_w(1 - n)(1 + w)$	G_s, w, S	$\frac{G_s\gamma_w}{1 + \left(\frac{wG_s}{S}\right)}$	e, w_{sat}	$\left(\frac{e}{w_{sat}}\right)\left(\frac{1 + w_{sat}}{1 + e}\right)\gamma_w$
S, G_s, n	$G_s\gamma_w(1 - n) + nS\gamma_w$	e, w, S	$\frac{eS\gamma_w}{(1 + e)w}$	n, w_{sat}	$n\left(\frac{1 + w_{sat}}{w_{sat}}\right)\gamma_w$
		γ_{sat}, e	$\gamma_{sat} - \frac{e\gamma_w}{1 + e}$	γ_d, e	$\gamma_d + \left(\frac{e}{1 + e}\right)\gamma_w$
		γ_{sat}, n	$\gamma_{sat} - n\gamma_w$	γ_d, n	$\gamma_d + n\gamma_w$
		γ_{sat}, G_s	$\frac{(\gamma_{sat} - \gamma_w)G_s}{(G_s - 1)}$	γ_d, S	$\left(1 - \frac{1}{G_s}\right)\gamma_d + \gamma_w$
				γ_d, w_{sat}	$\gamma_d(1 + w_{sat})$

Table 3.2 Void Ratio, Moisture Content, and Dry Unit Weight for Some Typical Soils in a Natural State

Type of soil	Void ratio, e	Natural moisture content in a saturated state (%)	Dry unit weight, γ_d	
			lb/ft ³	kN/m ³
Loose uniform sand	0.8	30	92	14.5
Dense uniform sand	0.45	16	115	18
Loose angular-grained silty sand	0.65	25	102	16
Dense angular-grained silty sand	0.4	15	121	19
Stiff clay	0.6	21	108	17
Soft clay	0.9–1.4	30–50	73–93	11.5–14.5
Loess	0.9	25	86	13.5
Soft organic clay	2.5–3.2	90–120	38–51	6–8
Glacial till	0.3	10	134	21

Table C10.6.2.6.1-1—Presumptive Bearing Resistance for Spread Footing Foundations at the Service Limit State Modified after U.S. Department of the Navy (1982)

Type of Bearing Material	Consistency in Place	Bearing Resistance (ksf)	
		Ordinary Range	Recommended Value of Use
Massive crystalline igneous and metamorphic rock: granite, diorite, basalt, gneiss, thoroughly cemented conglomerate (sound condition allows minor cracks)	Very hard, sound rock	120–200	160
Foliated metamorphic rock: slate, schist (sound condition allows minor cracks)	Hard sound rock	60–80	70
Sedimentary rock: hard cemented shales, siltstone, sandstone, limestone without cavities	Hard sound rock	30–50	40
Weathered or broken bedrock of any kind, except highly argillaceous rock (shale)	Medium hard rock	16–24	20
Compaction shale or other highly argillaceous rock in sound condition	Medium hard rock	16–24	20
Well-graded mixture of fine- and coarse-grained soil: glacial till, hardpan, boulder clay (GW-GC, GC, SC)	Very dense	16–24	20
Gravel, gravel-sand mixture, boulder-gravel mixtures (GW, GP, SW, SP)	Very dense	12–20	14
	Medium dense to dense	8–14	10
	Loose	4–12	6
Coarse to medium sand, and with little gravel (SW, SP)	Very dense	8–12	8
	Medium dense to dense	4–8	6
	Loose	2–6	3
Fine to medium sand, silty or clayey medium to coarse sand (SW, SM, SC)	Very dense	6–10	6
	Medium dense to dense	4–8	5
	Loose	2–4	3
Fine sand, silty or clayey medium to fine sand (SP, SM, SC)	Very dense	6–10	6
	Medium dense to dense	4–8	5
	Loose	2–4	3
Homogeneous inorganic clay, sandy or silty clay (CL, CH)	Very dense	6–12	8
	Medium dense to dense	2–6	4
	Loose	1–2	1
Inorganic silt, sandy or clayey silt, varved silt-clay-fine sand (ML, MH)	Very stiff to hard	4–8	6
	Medium stiff to stiff	2–6	3
	Soft	1–2	1

10.6.2.6.2—Semiempirical Procedures for Bearing Resistance

Bearing resistance on rock shall be determined using empirical correlation to the Geomechanic Rock Mass Rating System, RMR. Local experience should be considered in the use of these semi-empirical procedures.

If the recommended value of presumptive bearing resistance exceeds either the unconfined compressive strength of the rock or the nominal resistance of the concrete, the presumptive bearing resistance shall be taken as the lesser of the unconfined compressive strength of the rock or the nominal resistance of the concrete. The nominal resistance of concrete shall be taken as $0.3f'_c$.

Table 10.5.5.2.2-1—Resistance Factors for Geotechnical Resistance of Shallow Foundations at the Strength Limit State

		Method/Soil/Condition	Resistance Factor
Bearing Resistance	ϕ_b	Theoretical method (Munfakh et al., 2001), in clay	0.50
		Theoretical method (Munfakh et al., 2001), in sand, using <i>CPT</i>	0.50
		Theoretical method (Munfakh et al., 2001), in sand, using <i>SPT</i>	0.45
		Semi-empirical methods (Meyerhof, 1957), all soils	0.45
		Footings on rock	0.45
		Plate Load Test	0.55
Sliding	ϕ_τ	Precast concrete placed on sand	0.90
		Cast-in-Place Concrete on sand	0.80
		Cast-in-Place or precast Concrete on Clay	0.85
		Soil on soil	0.90
	ϕ_{ep}	Passive earth pressure component of sliding resistance	0.50

The resistance factors in Table 10.5.5.2.2-1 were developed using both reliability theory and calibration by fitting to Allowable Stress Design (ASD). In general, ASD safety factors for footing bearing capacity range from 2.5 to 3.0, corresponding to a resistance factor of approximately 0.55 to 0.45, respectively, and for sliding, an ASD safety factor of 1.5, corresponding to a resistance factor of approximately 0.9. Calibration by fitting to ASD controlled the selection of the resistance factor in cases where statistical data were limited in quality or quantity.

The resistance factor for sliding of cast-in-place concrete on sand is slightly lower than the other sliding resistance factors based on reliability theory analysis (Barker et al., 1991). The higher interface friction coefficient used for sliding of cast-in-place concrete on sand relative to that used for precast concrete on sand causes the cast-in-place concrete sliding analysis to be less conservative, resulting in the need for the lower resistance factor. A more detailed explanation of the development of the resistance factors provided in Table 10.5.5.2.2-1 is provided in Allen (2005).

The resistance factors for plate load tests and passive resistance were based on engineering judgment and past ASD practice.

10.5.5.2.3—Driven Piles

Resistance factors shall be selected from Table 10.5.5.2.3-1 based on the method used for determining the driving criterion necessary to achieve the required nominal pile bearing resistance.

Regarding load tests, and dynamic tests with signal matching, the number of tests to be conducted to justify the design resistance factors selected should be based on the variability in the properties and geologic stratification of the site to which the test results are to be applied. A site shall be defined as a project site, or a portion of it, where the subsurface conditions can be characterized as geologically similar in terms of subsurface stratification, i.e., sequence, thickness, and geologic history of strata, the engineering properties of the strata, and groundwater conditions.

C10.5.5.2.3

Where nominal pile bearing resistance is determined by static load test, dynamic testing, wave equation, or dynamic formulas, the uncertainty in the nominal resistance is strictly due to the reliability of the resistance determination method used in the field during pile installation.

In most cases, the nominal bearing resistance of each production pile is field-verified based on compliance with a driving criterion developed using a dynamic method (see Articles 10.7.3.8.2, 10.7.3.8.3, 10.7.3.8.4, or 10.7.3.8.5). The actual penetration depth where the pile is stopped using the driving criterion (e.g., a blow count measured during pile driving) will likely not be the same as the estimated depth from the static analysis. Hence, the reliability of the nominal pile bearing resistance is dependent on the reliability of the

Consideration should be given to the relative change in the computed nominal resistance based on effective versus gross footing dimensions for the size of footings typically used for bridges. Judgment should be used in deciding whether the use of gross footing dimensions for computing nominal bearing resistance at the strength limit state would result in a conservative design.

10.6.3.1.2—Theoretical Estimation

10.6.3.1.2a—Basic Formulation

C10.6.3.1.2a

The nominal bearing resistance shall be estimated using accepted soil mechanics theories and should be based on measured soil parameters. The soil parameters used in the analyses shall be representative of the soil shear strength under the considered loading and subsurface conditions.

The nominal bearing resistance of spread footings on cohesionless soils shall be evaluated using effective stress analyses and drained soil strength parameters.

The nominal bearing resistance of spread footings on cohesive soils shall be evaluated for total stress analyses and undrained soil strength parameters. In cases where the cohesive soils may soften and lose strength with time, the bearing resistance of these soils shall also be evaluated for permanent loading conditions using effective stress analyses and drained soil strength parameters.

For spread footings bearing on compacted soils, the nominal bearing resistance shall be evaluated using the more critical of either total or effective stress analyses.

Except as noted below, the nominal bearing resistance of a soil layer, in ksf, should be taken as:

$$q_n = cN_{cm} + \gamma D_f N_{qm} C_{wq} + 0.5\gamma B N_{\gamma m} C_{w\gamma} \quad (10.6.3.1.2a-1)$$

in which:

$$N_{cm} = N_c s_c i_c \quad (10.6.3.1.2a-2)$$

$$N_{qm} = N_q s_q d_q i_q \quad (10.6.3.1.2a-3)$$

$$N_{\gamma m} = N_{\gamma} s_{\gamma} i_{\gamma} \quad (10.6.3.1.2a-4)$$

where:

- c = cohesion, taken as undrained shear strength (ksf)
- N_c = cohesion term (undrained loading) bearing capacity factor as specified in Table 10.6.3.1.2a-1 (dim)
- N_q = surcharge (embedment) term (drained or undrained loading) bearing capacity factor as specified in Table 10.6.3.1.2a-1 (dim)

The bearing resistance formulation provided in Eqs. 10.6.3.1.2a-1 through 10.6.3.1.2a-4 is the complete formulation as described in the Munfakh, et al. (2001). However, in practice, not all of the factors included in these equations have been routinely used.

where:

- B = footing width (ft)
- L = footing length (ft)
- H = unfactored horizontal load (kips)
- V = unfactored vertical load (kips)
- θ = projected direction of load in the plane of the footing, measured from the side of length L (degrees)

In practice, therefore, for footings with modest embedment, consideration may be given to omission of the load inclination factors.

Figure C10.6.3.1.2a-1 shows the convention for determining the θ angle in Eq. 10.6.3.1.2a-9.

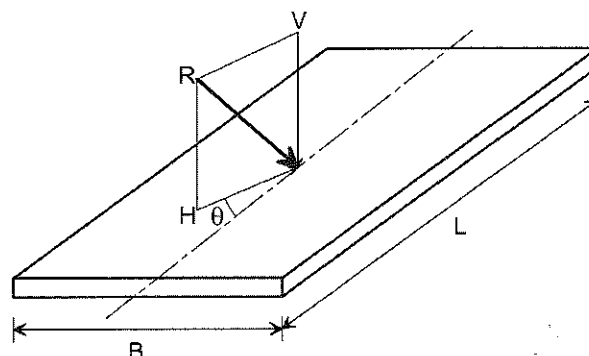

Figure C10.6.3.1.2a-1—Inclined Loading Conventions

Table 10.6.3.1.2a-1—Bearing Capacity Factors N_c (Prandtl, 1921), N_q (Reissner, 1924), and N_γ (Vesic, 1975)

ϕ_f	N_c	N_q	N_γ	ϕ_f	N_c	N_q	N_γ
0	5.14	1.0	0.0	23	18.1	8.7	8.2
1	5.4	1.1	0.1	24	19.3	9.6	9.4
2	5.6	1.2	0.2	25	20.7	10.7	10.9
3	5.9	1.3	0.2	26	22.3	11.9	12.5
4	6.2	1.4	0.3	27	23.9	13.2	14.5
5	6.5	1.6	0.5	28	25.8	14.7	16.7
6	6.8	1.7	0.6	29	27.9	16.4	19.3
7	7.2	1.9	0.7	30	30.1	18.4	22.4
8	7.5	2.1	0.9	31	32.7	20.6	26.0
9	7.9	2.3	1.0	32	35.5	23.2	30.2
10	8.4	2.5	1.2	33	38.6	26.1	35.2
11	8.8	2.7	1.4	34	42.2	29.4	41.1
12	9.3	3.0	1.7	35	46.1	33.3	48.0
13	9.8	3.3	2.0	36	50.6	37.8	56.3
14	10.4	3.6	2.3	37	55.6	42.9	66.2
15	11.0	3.9	2.7	38	61.4	48.9	78.0
16	11.6	4.3	3.1	39	67.9	56.0	92.3
17	12.3	4.8	3.5	40	75.3	64.2	109.4
18	13.1	5.3	4.1	41	83.9	73.9	130.2
19	13.9	5.8	4.7	42	93.7	85.4	155.6
20	14.8	6.4	5.4	43	105.1	99.0	186.5
21	15.8	7.1	6.2	44	118.4	115.3	224.6
22	16.9	7.8	7.1	45	133.9	134.9	271.8

Table 10.6.3.1.2a-2—Coefficients C_{wg} and C_{wy} for Various Groundwater Depths

D_w	C_{wg}	C_{wy}
0.0	0.5	0.5
D_f	1.0	0.5
$>1.5B + D_f$	1.0	1.0

Where the position of groundwater is at a depth less than 1.5 times the footing width below the footing base, the bearing resistance is affected. The highest anticipated groundwater level should be used in design.

Table 10.6.3.1.2a-3—Shape Correction Factors s_c, s_γ, s_q

Factor	Friction Angle	Cohesion Term (s_c)	Unit Weight Term (s_γ)	Surcharge Term (s_q)
Shape Factors s_c, s_γ, s_q	$\phi_f = 0$	$1 + \left(\frac{B}{5L}\right)$	1.0	1.0
	$\phi_f > 0$	$1 + \left(\frac{B}{L}\right)\left(\frac{N_c}{N_c}\right)$	$1 - 0.4\left(\frac{B}{L}\right)$	$1 + \left(\frac{B}{L} \tan \phi_f\right)$

Table 10.6.3.1.2a-4—Depth Correction Factor d_q

Friction Angle, ϕ_f (degrees)	D_f/B	d_q
32	1	1.20
	2	1.30
	4	1.35
	8	1.40
37	1	1.20
	2	1.25
	4	1.30
	8	1.35
42	1	1.15
	2	1.20
	4	1.25
	8	1.30

The parent information from which Table 10.6.3.1.2a-4 was developed covered the indicated range of friction angle, ϕ_f . Information beyond the range indicated is not available at this time.

The depth correction factor should be used only when the soils above the footing bearing elevation are as competent as the soils beneath the footing level; otherwise, the depth correction factor should be taken as 1.0.

Linear interpolations may be made for friction angles in between those values shown in Table 10.6.3.1.2a-4.

10.6.3.1.2b—Considerations for Punching Shear

C10.6.3.1.2b

If local or punching shear failure is possible, the nominal bearing resistance shall be estimated using reduced shear strength parameters c^* and ϕ^* in Eqs. 10.6.3.1.2b-1 and 10.6.3.1.2b-2. The reduced shear parameters may be taken as:

$$c^* = 0.67c \tag{10.6.3.1.2b-1}$$

$$\phi^* = \tan^{-1}(0.67 \tan \phi_f) \tag{10.6.3.1.2b-2}$$

where:

- c^* = reduced effective stress soil cohesion for punching shear (ksf)
- ϕ^* = reduced effective stress soil friction angle for punching shear (degrees)

Local shear failure is characterized by a failure surface that is similar to that of a general shear failure but that does not extend to the ground surface, ending somewhere in the soil below the footing. Local shear failure is accompanied by vertical compression of soil below the footing and visible bulging of soil adjacent to the footing but not by sudden rotation or tilting of the footing. Local shear failure is a transitional condition between general and punching shear failure. Punching shear failure is characterized by vertical shear around the perimeter of the footing and is accompanied by a vertical movement of the footing and compression of the soil immediately below the footing but does not affect the soil outside the loaded area. Punching shear failure occurs in loose or compressible soils, in weak soils under slow (drained) loading, and in dense sands for deep footings subjected to high loads.

N1 60 and Soil Internal Angle of Friction Correlation
AASHTO Table 10.4.6.2.4-1 and Commentary C10.4.6.2.4
Correlation per Peck, Hanson and Thornburn with ranges for Fine (blue), Medium (orange) and Coarse (grey) materials

N160- ϕ f Correlation
(AASHTO Table 10.4.6.2.4-1)

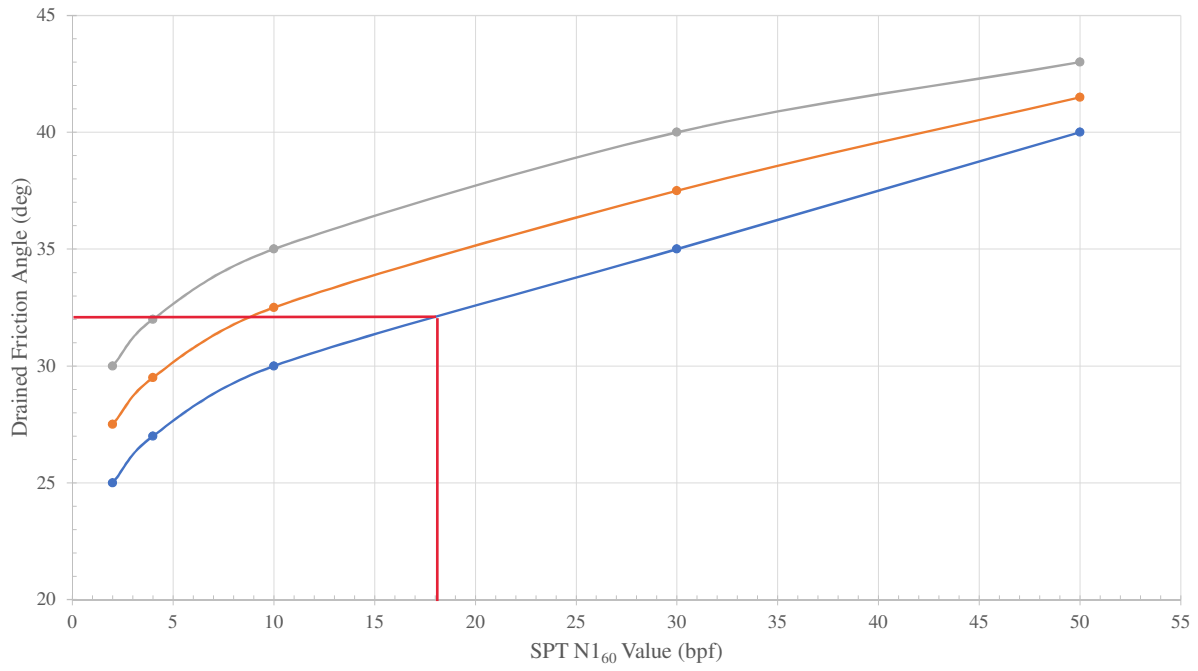

Modulus of Subgrade Reaction

Objective:

Estimate the modulus of subgrade reaction for the box culvert base slab design.

Given:

1. Limited lab data and SPT N-values.

Assumptions:

1. The proposed bearing elevation of base slab is approximately 420.0 feet.
2. Proposed finished roadway grade is approximately 436.5.
3. Proposed precast concrete box is 28 feet wide and approximately 88 feet long.
4. The subsurface conditions present at the proposed bearing elevation is medium dense to dense SAND and stiff silt (model as medium dense SAND).
5. The bottom of the box culvert will be submerged for the structure's design life.

Published values of subgrade modulus

Published values of subgrade modulus in silty sand:

Bowles Foundation Analysis and Design, 5th ed. Table 9-1:

Range of modulus of subgrade reaction 88 to 177 pci

Subgrade of medium dense silty sand, average of upper and lower limit: $k_s = 133$ pci

FHWA Geotechnical Engineering Circular (GEC) No. 6, Figure 8-3:

Saturated coarse grained medium dense sand K_{v1} , $150 \text{ pci} / 2 = 75$ pci

Das Principles of Foundation Engineering, 7th ed. Table 6.2:

Typical subgrade reaction values for 0.3 m x 0.3 m plate

Saturated medium sand, 129 - 147 pci: $k_{0.3}(k_1) = 140$ pci

Terzaghi Geotechnique, Vol. 5, No. 4, Table 1:

Values of vertical subgrade reaction for 1 ft x 1 ft plate on sand

Submerged medium sand: $k_{s1} = 93$ pci

Adjust Published values for dimensions of base slab

Select a subgrade modulus of 150 pci for saturated dense sand based on GEC No. 6. and divided by 2 per Note 2 (see references attached).

Value of $k_{s1} = 93$ pci is for a 1 ft x 1 ft plate. Adjust to the dimensions of the box culvert base (Width B = 28 ft, Length L = 88 ft).

Square to rectangle base adjustment:

$$k_{s1} := 93 \text{ pci} \quad B := 28 \text{ ft} \quad L := 88 \text{ ft}$$

$$k := \frac{k_{s1} \cdot \left[1 + 0.5 \left(\frac{B}{L} \right) \right]}{1.5}$$

Das, Principles of Foundation
Engineering 7th Ed. P. 311 Eqn. 6.44

$$k = 71.9 \cdot \text{pci}$$

Recommend a subgrade modulus of 72 pci

for either a horizontal or lateral modulus of subgrade reaction is

$$k_s = A_s + B_s Z^n \quad (9-10)$$

for either horizontal or vertical members

for depth variation

of interest below ground

to give k_s the best fit (if load test or other data are available)

variation may be zero; at the ground surface A_s is zero for a lateral k_s

> 0 . For footings and mats (plates in general), $A_s > 0$ and $B_s \cong 0$.

used with the proper interpretation of the bearing-capacity equa-

tion d_i factors dropped) to give

$$q_{ult} = cN_c s_c + \gamma Z N_q s_q + 0.5 \gamma B N_\gamma s_\gamma \quad (9-10a)$$

$$s_c + 0.5 \gamma B N_\gamma s_\gamma \quad \text{and} \quad B_s Z^1 = C(\gamma N_q s_q) Z^1$$

to estimate k_s . In these equations the Terzaghi or Hansen bearing-

capacity factors are used. The C factor is 40 for SI units and 12 for Fps, using the same

settlement but with no SF, since this equation is based on a settlement of

1.25 in. (32 mm) where there is concern that k_s does not increase without bound with

depth. The $B_s Z$ term by one of two simple methods:

$$\text{Method 1: } B_s \tan^{-1} \frac{Z}{D}$$

$$\text{Method 2: } \frac{B_s}{D^n} Z^n = B'_s Z^n$$

depth of interest, say, the length of a pile

of interest

to estimate of the exponent

to estimate a value of k_s to determine the correct order of magnitude

obtained using one of the approximations given here. Obviously if a

value is three times larger than the table range indicates, the computations

will have a possible gross error. Note, however, if you use a reduced value of

settlement (or 12 mm) instead of 0.0254 m you may well exceed the table range.

If a computational error (or a poor assumption) is found then use judgment

to estimate table values are intended as guides. The reader should not use, say,

an estimate even as a "good" estimate.

shown in Fig. 9-9c (and used in your diskette program FADBEMLP as

estimated at some small value of, say, 6 to 25 mm, or from inspection

of a load test was done. It might also be estimated from a triaxial

test "ultimate" or at the maximum pressure from the stress-strain plot.

to compute

$$X_{max} = \epsilon_{max}(1.5 \text{ to } 2B)$$

TABLE 9-1

Range of modulus of subgrade

reaction k_s

Use values as guide and for comparison when using approximate equations $\frac{kN}{M^3} \rightarrow \frac{lb}{in^3} : \frac{224.8 lb}{1 kN} * \frac{1M^3}{61023.7 in^3} = .003684 \frac{kN}{M^3} = 1 \frac{lb}{in^3}$

Soil	$k_s, kN/m^3$	$k_s, lb/in^3$
Loose sand	4800-16,000	18 - 59
Medium dense sand	9600-80,000	35 - 295
Dense sand	64,000-128,000	236 - 472
Clayey medium dense sand	32,000-80,000	118 - 295
Silty medium dense sand	24,000-48,000	88 - 177
Clayey soil:		
$q_a \leq 200$ kPa	12,000-24,000	44 - 88
$200 < q_a \leq 800$ kPa	24,000-48,000	88 - 177
$q_a > 800$ kPa	> 48,000	> 177

133 pci

The 1.5 to 2B dimension is an approximation of the depth of significant stress-strain influence (Boussinesq theory) for the structural member. The structural member may be either a footing or a pile.

Example 9-5. Estimate the modulus of subgrade reaction k_s for the following design parameters:

$$B = 1.22 \text{ m} \quad L = 1.83 \text{ m} \quad D = 0.610 \text{ m}$$

$$q_a = 200 \text{ kPa (clayey sand approximately 10 m deep)}$$

$$E_s = 11.72 \text{ MPa (average in depth } 5B \text{ below base)}$$

Solution. Estimate Poisson's ratio $\mu = 0.30$ so that

$$E'_s = \frac{1 - \mu^2}{E_s} = \frac{1 - 0.3^2}{11.72} = 0.07765 \text{ m}^2/\text{MN}$$

For center:

$$H/B' = 5B/(B/2) = 10 \text{ (taking } H = 5B \text{ as recommended in Chap. 5)}$$

$$L/B = 1.83/1.22 = 1.5$$

From these we may write

$$I_s = 0.584 + \frac{1 - 2(0.3)}{1 - 0.3} (0.023) = 0.597$$

using Eq. (5-16) and Table 5-2 (or your program FFACTOR) for factors 0.584 and 0.023.

At $D/B = 0.61/1.22 = 0.5$, we obtain $I_F = 0.80$ from Fig. 5-7 (or when using FFACTOR for the I_s factors). Substitution into Eq. (9-7) with $B' = 1.22/2 = 0.61$, and $m = 4$ yields

$$k_s = \frac{1}{0.61(0.07765)(4 \times 0.597)(0.8)} = 11.05 \text{ MN/m}^3$$

You should note that k_s does not depend on the contact pressure of the base q_o .

For corner:

$$H/B' = 5B/B = 5(1.22)/1.22 = 5$$

[from Table 5-2 with $L/B = 1.5$ obtained for Eq. (5-16)]

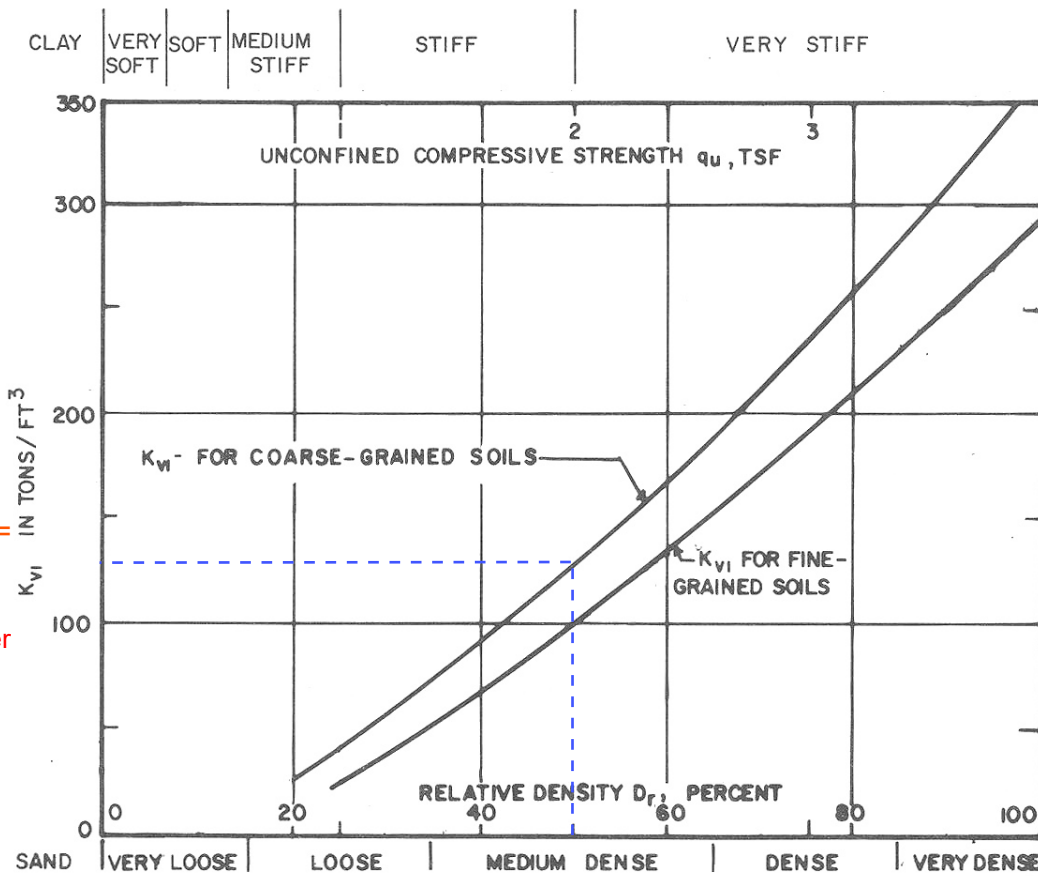

130 TCF =
150 PCI
Reduce per
Note 2

DEFINITIONS

- ΔH_i = IMMEDIATE SETTLEMENT OF FOOTING
- q = FOOTING UNIT LOAD IN tsf
- B = FOOTING WIDTH

- D = DEPTH OF FOOTING BELOW GROUND SURFACE
- K_{v1} = MODULUS OF VERTICAL SUBGRADE REACTION

$$\frac{\text{ton}}{\text{ft}^3} \rightarrow \frac{\text{lb}}{\text{in}^3} = \frac{2000 \text{ lb}}{1 \text{ ton}} * \frac{1 \text{ ft}^3}{1728 \text{ in}^3} = 1.157 \frac{\text{ton}}{\text{ft}^3} \rightarrow 1 \frac{\text{lb}}{\text{in}^3}$$

COARSE-GRAINED SOILS

(MODULUS OF ELASTICITY INCREASING LINEARLY WITH DEPTH)
SHALLOW FOOTINGS $D \leq B$

FOR $B \leq 20$ FT:

$$\Delta H_i = \frac{4 q B^2}{K_{v1} (B+1)^2}$$

FOR $B \geq 40$ FT:

$$\Delta H_i = \frac{2 q B^2}{K_{v1} (B+1)^2}$$

INTERPOLATE FOR INTERMEDIATE VALUES OF B

DEEP FOUNDATION $D \geq 5B$

FOR $B \leq 20$ FT:

$$\Delta H_i = \frac{2 q B^2}{K_{v1} (B+1)^2}$$

NOTES: 1. NONPLASTIC SILT IS ANALYZED AS COARSE-GRAINED SOIL WITH MODULUS OF ELASTICITY INCREASING LINEARLY WITH DEPTH.

2. VALUES OF K_{v1} SHOWN FOR COARSE-GRAINED SOILS APPLY TO DRY OR MOIST MATERIAL WITH THE GROUNDWATER LEVEL AT A DEPTH OF AT LEAST $1.5B$ BELOW BASE OF FOOTING. IF GROUNDWATER IS AT BASE OF FOOTING, USE $K_{v1}/2$ IN COMPUTING SETTLEMENT

Figure 8-3: Modulus of Subgrade Reaction (NAVFAC, 1986a)

Equation (6.44) indicates that the value of k for a very long foundation with a width B is approximately $0.67k_{(B \times B)}$.

The modulus of elasticity of granular soils increases with depth. Because the settlement of a foundation depends on the modulus of elasticity, the value of k increases with the depth of the foundation.

Table 6.2 provides typical ranges of values for the coefficient of subgrade reaction, $k_{0.3}(k_1)$, for sandy and clayey soils.

For long beams, Vesic (1961) proposed an equation for estimating subgrade reaction, namely,

$$k' = Bk = 0.65 \sqrt[12]{\frac{E_s B^4}{E_F I_F}} \frac{E_s}{1 - \mu_s^2}$$

or

$$k = 0.65 \sqrt[12]{\frac{E_s B^4}{E_F I_F}} \frac{E_s}{B(1 - \mu_s^2)} \tag{6.45}$$

where

- E_s = modulus of elasticity of soil
- B = foundation width
- E_F = modulus of elasticity of foundation material
- I_F = moment of inertia of the cross section of the foundation
- μ_s = Poisson's ratio of soil

$$\frac{MN}{m^3} \rightarrow \frac{lb}{in^3}; \frac{224809 lb}{1 MN} * \frac{1 m^3}{61024 in^3} \rightarrow 3.684 \frac{lb}{in^3} = \frac{1 MN}{M^3}$$

Table 6.2 Typical Subgrade Reaction Values, $k_{0.3}(k_1)$

Soil type	$k_{0.3}(k_1)$ MN/m ³	pci
Dry or moist sand:		
Loose	8–25	29 - 92
Medium	25–125	92 - 461
Dense	125–375	461 - 1382
Saturated sand:		
Loose	10–15	37 - 55
Medium	35–40	129 - 147
Dense	130–150	478 - 553
Clay:		
Stiff	10–25	37 - 92
Very stiff	25–50	92 - 184
Hard	>50	> 184

the bending moments in piles which are acted upon by horizontal forces above the ground surface (Cummings, 1937) and of those in core-walls of earth- and rock-fill dams (Löfquist, 1951).

Attempts have also been made to apply the theories to the solution of bulkhead problems (Rifaat, 1935). Baumann (1935) used them for estimating the stresses in an anchored bulkhead which had failed. Quite recently Blum (1951) proposed a procedure for the design of anchored bulkheads by means of the theory of horizontal subgrade reaction. All these investigations and design procedures were based on the tacit assumption that K'_0 in equation (15) is identical with the coefficient of active earth pressure K_a . The error due to this assumption may be quite important.

EVALUATION OF COEFFICIENTS OF SUBGRADE REACTION

General procedure

The numerical values of the coefficients of subgrade reaction k_s and k_h required for the solution of engineering problems can either be estimated on the basis of published observational data or else they can be derived from the results of field tests to be performed on the subgrade of the proposed structure. For practical purposes, rough estimates of these values fully serve their purpose.

Vertical subgrade reaction

As a basis for estimating the coefficient of subgrade reaction k_s for beams and slabs, the value \bar{k}_{s1} for a square plate with a width of 1 ft has been selected, because this value can, if necessary, be determined by averaging the results of several loading tests in the field, at the site of the structure.

If the subgrade consists of cohesionless or slightly cohesive sand, k_s can be estimated on the basis of the empirical values of \bar{k}_{s1} given in Table 1. The density-category of the sand can be ascertained by means of a standard penetration test or other convenient means. The greatest error on the unsafe side results from using the proposed value in the case of medium sand if its real value is equal to the lower limiting value of 60 tons/cu. ft.

Table 1.
Values of \bar{k}_{s1} in tons/cu. ft for square plates, 1 ft x 1 ft, or beams 1 ft wide, resting on sand

Relative density of sand	Loose	Medium	Dense
Dry or moist sand, limiting values for \bar{k}_{s1}	20-60	60-300	300-1,000
Dry or moist sand, proposed values	40	130	500
Submerged sand, proposed values	25	80	300

Medium sand

In order to investigate the influence of such an error on the results of the computation of the bending moments in a beam, the maximum bending moment M_{max} in the beam shown in Fig. 1 was computed on the basis of both the assumed and the real value of \bar{k}_{s1} for the supporting sand. The value of M_{max} for this beam is determined by equation (4). It was found that the moment computed by means of the proposed value exceeds the actual bending moment by not more than about 5%.

Once the value \bar{k}_{s1} has been selected, the value of k_s to be used in the solution of a given

$$\frac{\text{ton}}{\text{ft}^3} \rightarrow \frac{\text{lb}}{\text{in}^3} = \frac{2000 \text{ lb}}{1 \text{ ton}} * \frac{1 \text{ ft}^3}{1728 \text{ in}^3} = 1.157 \frac{\text{ton}}{\text{ft}^3} \rightarrow 1 \frac{\text{lb}}{\text{in}^3}$$

$$80 \text{ ton/ft}^3 \times 1.157 = 93 \text{ pci}$$

problem can be cor headings. Experien sand is roughly equ (Fig. 3) or for a mat equation (8) :

If applied to sp contact pressures su unit of area of the l porting concentrate half of the ultimate equation (9).

Values Range Proposed

For rec High

If the subgrade ately in simple pr basis of our presen numerical values of pressures which ar The latter is indep

The proposed v medium sand, Tab of the loaded area normally consolida beams and rafts sl perfectly rigid.

The \bar{k}_{s1} values of the tests can be of such tests is to the test results can of the block shoul

If the contact the value :

For $l = \infty$, $k_{s1} =$ loaded subgrade 1

The unit of k is kN/m^3 . The value of the coefficient of subgrade reaction is not a constant for a given soil, but rather depends on several factors, such as the length L and width B of the foundation and also the depth of embedment of the foundation. A comprehensive study by Terzaghi (1955) of the parameters affecting the coefficient of subgrade reaction indicated that the value of the coefficient decreases with the width of the foundation. In the field, load tests can be carried out by means of square plates measuring $0.3 \text{ m} \times 0.3 \text{ m}$, and values of k can be calculated. The value of k can be related to large foundations measuring $B \times B$ in the following ways:

Foundations on Sandy Soils

For foundations on sandy soils,

$$k = k_{0.3} \left(\frac{B + 0.3}{2B} \right)^2 \quad (6.42)$$

where $k_{0.3}$ and k = coefficients of subgrade reaction of foundations measuring $0.3 \text{ m} \times 0.3 \text{ m}$ and $B \text{ (m)} \times B \text{ (m)}$, respectively (unit is kN/m^3).

Foundations on Clays

For foundations on clays,

$$k \text{ (kN/m}^3\text{)} = k_{0.3} \text{ (kN/m}^3\text{)} \left[\frac{0.3 \text{ (m)}}{B \text{ (m)}} \right] \quad (6.43)$$

The definitions of k and $k_{0.3}$ in Eq. (6.43) are the same as in Eq. (6.42).

For rectangular foundations having dimensions of $B \times L$ (for similar soil and q),

$$k = \frac{k_{(B \times B)} \left(1 + 0.5 \frac{B}{L} \right)}{1.5} \quad (6.44)$$

Method 1:

where

k = coefficient of subgrade modulus of the rectangular foundation ($L \times B$)
 $k_{(B \times B)}$ = coefficient of subgrade modulus of a square foundation having dimension of $B \times B$

Frost

**Method 1 - MaineDOT Design Freezing Index (DFI) Map and Depth of Frost Penetration Table, BDG
Section 5.2.1.**

From Design Freezing Index Map: **Jackson, Maine**

DFI = 1600 degree-days.

Case 1 - fine grained alluvial soils W=15% (BB-JFGFB-101 2D).

For DFI = 1600

at w=20% $d_1 := 60.2\text{in}$

at w=10% $d_2 := 51.9\text{in}$

Depth of Frost Penetration

$$d := \frac{d_2 + d_1}{2} \quad d = 56.05 \cdot \text{in} \quad d = 4.7 \cdot \text{ft}$$

Figure 5-1 Maine Design Freezing Index Map

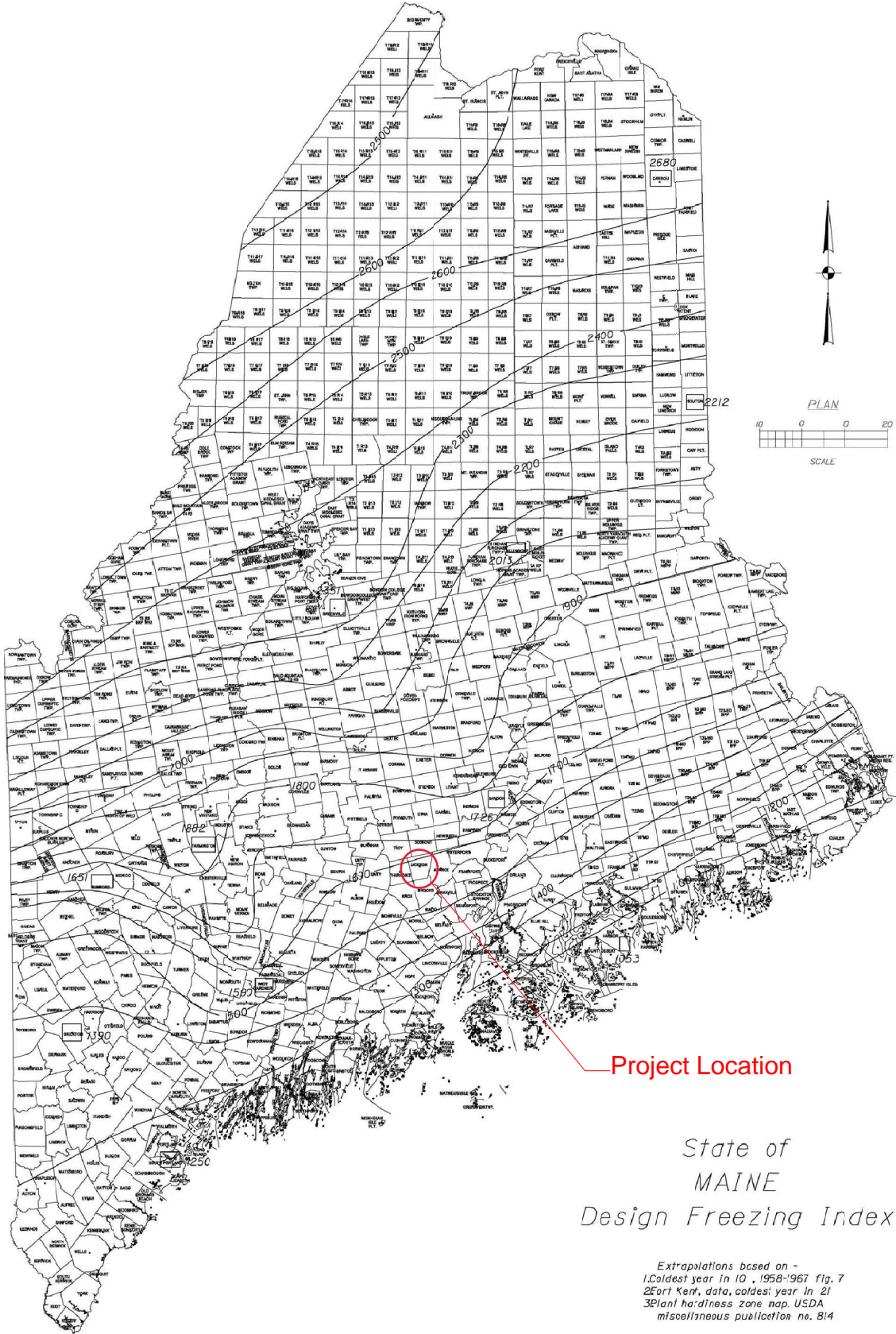

5.2 General

MaineDOT Bridge Design Guide

5.2.1 Frost

Any foundation placed on seasonally frozen soils must be embedded below the depth of frost penetration to provide adequate frost protection and to minimize the potential for freeze/thaw movements. Fine-grained soils with low cohesion tend to be most frost susceptible. Soils containing a high percentage of particles smaller than the No. 200 sieve also tend to promote frost penetration.

In order to estimate the depth of frost penetration at a site, Table 5-1 has been developed using the Modified Berggren equation and Figure 5-1 Maine Design Freezing Index Map. The use of Table 5-1 assumes site specific, uniform soil conditions where the Geotechnical Designer has evaluated subsurface conditions. Coarse-grained soils are defined as soils with sand as the major constituent. Fine-grained soils are those having silt and/or clay as the major constituent. If the make-up of the soil is not easily discerned, consult the Geotechnical Designer for assistance. In the event that specific site soil conditions vary, the depth of frost penetration should be calculated by the Geotechnical Designer.

Table 5-1 Depth of Frost Penetration

Design Freezing Index	Frost Penetration (in)					
	Coarse Grained			Fine Grained		
	w=10%	w=20%	w=30%	w=10%	w=20%	w=30%
1000	66.3	55.0	47.5	47.1	40.7	36.9
1100	69.8	57.8	49.8	49.6	42.7	38.7
1200	73.1	60.4	52.0	51.9	44.7	40.5
1300	76.3	63.0	54.3	54.2	46.6	42.2
1400	79.2	65.5	56.4	56.3	48.5	43.9
1500	82.1	67.9	58.4	58.3	50.2	45.4
1600	84.8	70.2	60.3	60.2	51.9	46.9
1700	87.5	72.4	62.2	62.2	53.5	48.4
1800	90.1	74.5	64.0	64.0	55.1	49.8
1900	92.6	76.6	65.7	65.8	56.7	51.1
2000	95.1	78.7	67.5	67.6	58.2	52.5
2100	97.6	80.7	69.2	69.3	59.7	53.8
2200	100.0	82.6	70.8	71.0	61.1	55.1
2300	102.3	84.5	72.4	72.7	62.5	56.4
2400	104.6	86.4	74.0	74.3	63.9	57.6
2500	106.9	88.2	75.6	75.9	65.2	58.8
2600	109.1	89.9	77.1	77.5	66.5	60.0