

# STATE OF MAINE DEPARTMENT OF TRANSPORTATION



## WESTBROOK CUMBERLAND

WILLIAM B. CLARKE DRIVE  
**FEDERAL PROJECT 2379700**  
PROJECT LENGTH : 0.31 MILES

PLAN LEGEND	
Town, County, State	-----
Property Lines	-----
R/W Lines-Existing	-----
R/W Lines-Proposed	-----
Culvert-Existing	-----
Culvert Proposed	-----
Curbing Existing	-----
Curbing Proposed	-----
Type 1	-----
Type 3	-----
Type 5	-----
Outline of Bodies of Water	-----
Exposed Bedrock	-----
Buildings	-----
Trees	-----
Tree Line	-----
Clearing Limit Line	-----
Railroad	-----
Catch Basins	Existing [Symbol] Proposed [Symbol]
Manholes	Existing [Symbol] Proposed [Symbol]
Proposed Underdrain	-----
Proposed Ditch	-----
Existing Ditch	-----
Utility Poles	Existing [Symbol] Proposed [Symbol]
Fire Hydrants	Existing [Symbol] Proposed [Symbol]
Existing Water Line	-----
Existing San. Sewer	-----
Existing San. Sewer Manhole	[Symbol]
Guardrail-Existing	-----
Guardrail-Proposed	-----
Guardrail-Cable, Other	-----
Centerline-Existing	-----
Centerline-Proposed	-----
Travelway-Existing	-----
Travelway-Proposed	-----
Boring	[Symbol] HB-XXX-###
Pavement Core	[Symbol] PC-#
Test Pit	[Symbol] TP-XXX-###
Probe	[Symbol] P-#.##X
	## = Depth
	X = W (Weathered Rock)
	R (Refusal)
	NR (No Refusal)

INDEX OF SHEETS	
Description	Sheet No.
Title Sheet	1
Typical Sections	2-3
Estimated Quantities	4
Drainage Summary Sheet	5
General Notes	6
Mast Arm Foundations and Boring Location Plans	7
Boring Logs	8
Traffic Signal Plans	9-14
Lighting Plans	15-16
Lighting Details and Conduit Tables	17
Lighting Construction Notes	18
Striping, Marking, & Signing Plans	19-21
Geometric Plan	22
Curb Layout Plans	23-25
Plans	26-28
Cross Sections	29-43
Right of Way Map	44-46

STATE OF MAINE DEPARTMENT OF TRANSPORTATION	APPROVED	DATE
	<i>[Signature]</i>	12-20-21
	COMMISSIONER	
	<i>[Signature]</i>	12-20-21
	CHIEF ENGINEER	
	<i>[Signature]</i>	12-20-21

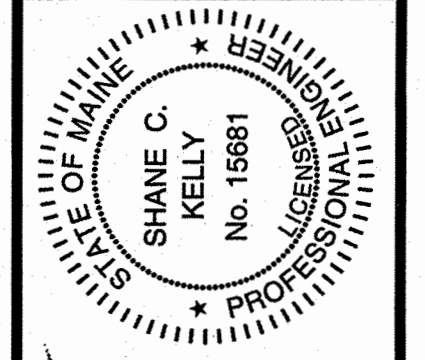

SIGNATURE	15681	DATE
	<i>[Signature]</i>	12/09/2021
P.E. NUMBER		
CONTRACTOR		

PROGRAM	PROJECT INFORMATION
PROJECT MANAGER	HIGHWAY
DESIGNER	E. MARTIN
CONSULTANT	S. KELLY
PROJECT RESIDENT	SEBAGO TECHNICS
CONTRACTOR	
PROJECT COMPLETION DATE	

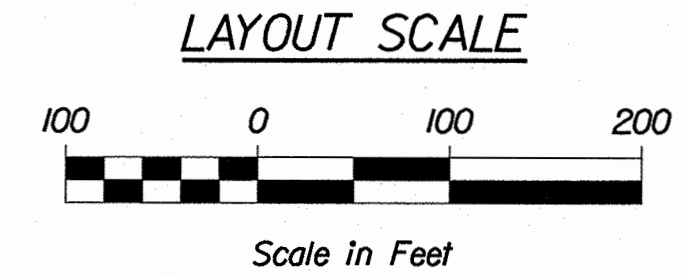
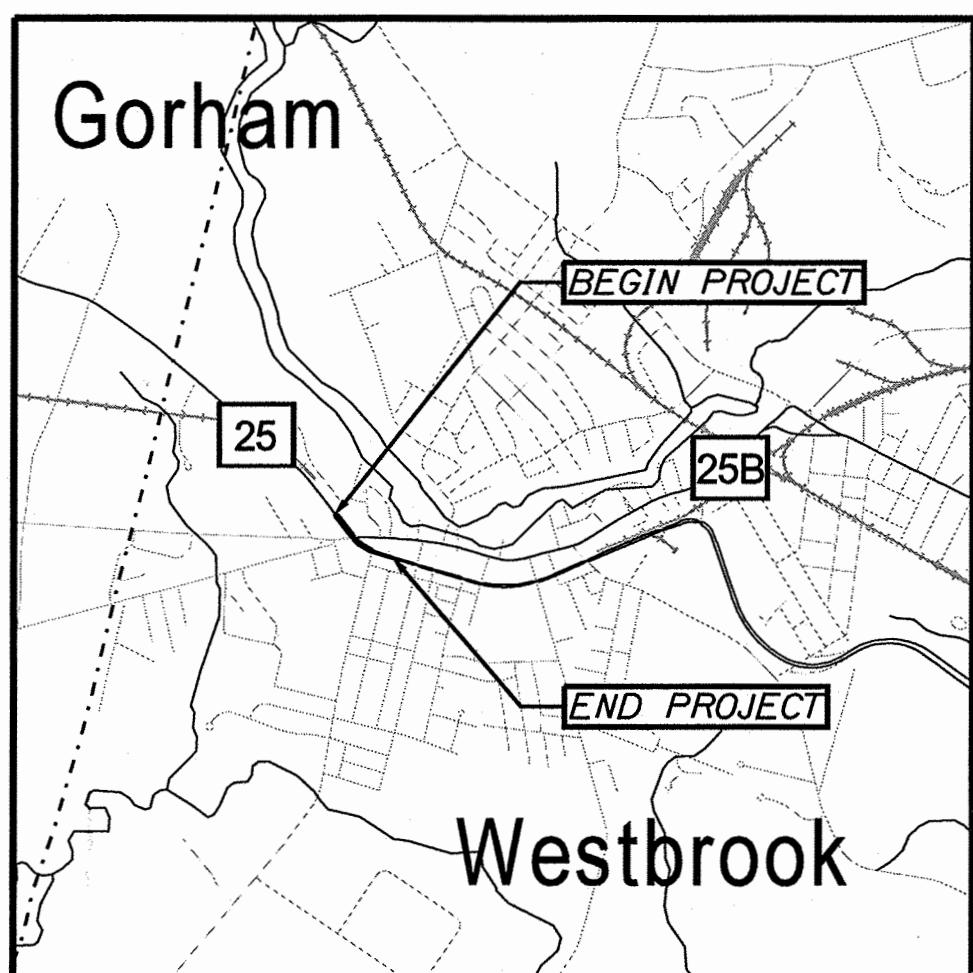
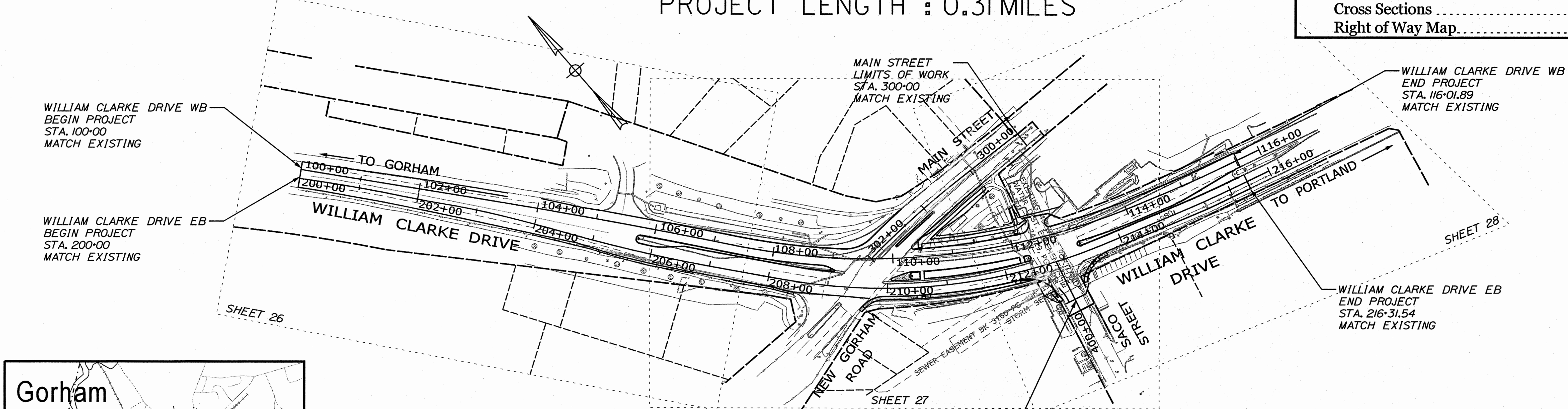

TRAFFIC DATA	WILLIAM CLARKE DR	MAIN ST
Current (2021) AADT	19,860	15,140
Future (2041) AADT	23,830	18,170
DHV - % of AADT	9%	10%
Design Hour Volume	2145	1817
% Heavy Trucks (AADT)	9%	9%
Directional Distribution (DHV)	64%	64%
Design Speed (mph)	35 to 40	25
Functional Class	Principal Arterial	Minor Arterial
Corridor Priority	1	3

<b>PROJECT LOCATION:</b>	ALONG WILLIAM CLARKE DRIVE BEGINNING 0.09 MILES WEST OF CONANT STREET AND EXTENDING 0.06 MILES EAST OF SACO STREET WITH INTERSECTION WORK AT BOTH MAIN STREET AND SACO STREET
<b>PROGRAM AREA:</b>	HIGHWAY PROGRAM
<b>SCOPE OF WORK:</b>	WILLIAM CLARKE DRIVE REHABILITATION AND TRAFFIC SIGNAL IMPROVEMENTS

WIN 23797.00 FEDERAL PROJECT 2379700

WESTBROOK  
WILLIAM CLARKE DRIVE  
TITLE SHEET

SHEET NUMBER  
**1**  
OF 46

Date: 12/9/2021

Username: skelly

Division: HIGHWAY

Filename: ... \MSTA\Sheet Sets \001\_ Title.dgn

NOTE: THE ELEVATIONS OF THE ROADWAY ARE CONTROLLED THROUGH PROFILE CONTROLS LABELED. THESE PROFILE CONTROLS ARE BASED ON THE EXISTING GROUND ELEVATION AT THE SPECIFIED LOCATION. WITHIN MILL AND OVERLAY AREAS, THE MILL DEPTH WILL BE CONSISTENT 3" AT THE PROFILE CONTROL AND MILLED OUTWARD TO THE SPECIFIED SLOPE.

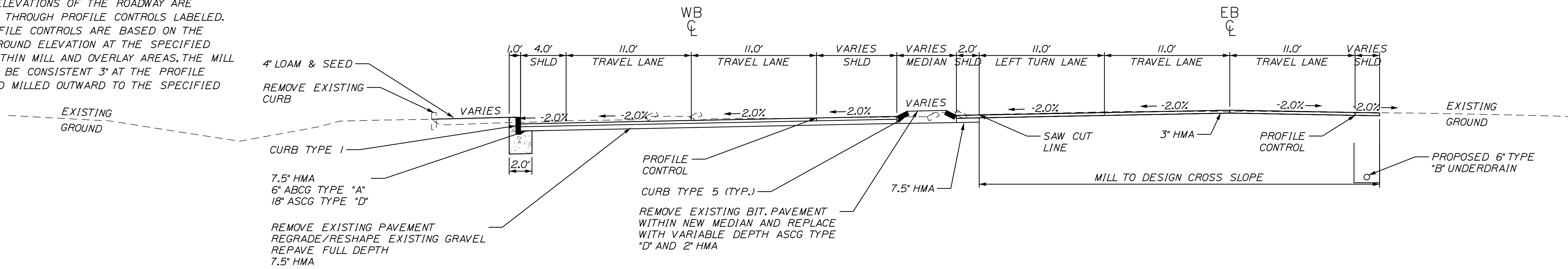

WILLIAM CLARKE DRIVE STA. 108+55 TO 110+00

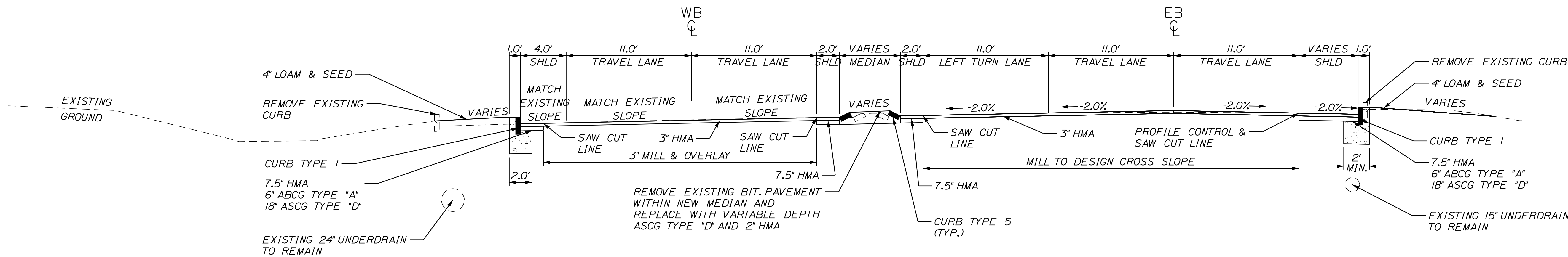

WILLIAM CLARKE DRIVE STA. 107+60 TO 108+55

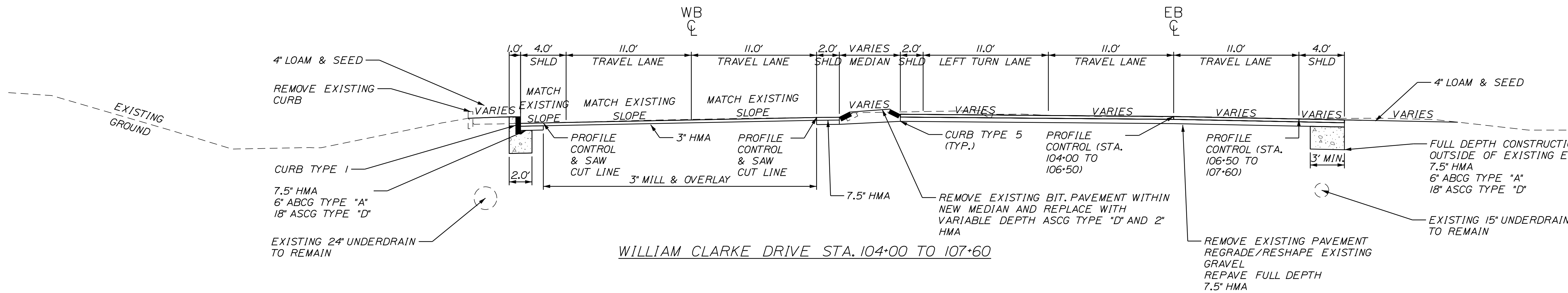

WILLIAM CLARKE DRIVE STA. 104+00 TO 107+60

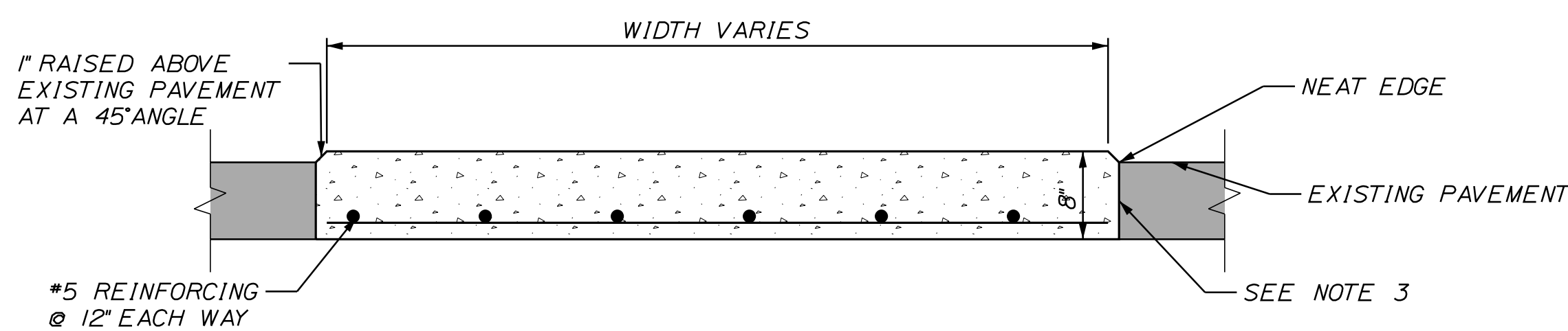

STRUCTURAL CONCRETE ROADWAY TRUCK APRON STA. 109+96 TO 110+33

ITEM NO. 502.342  
(NOT TO SCALE)

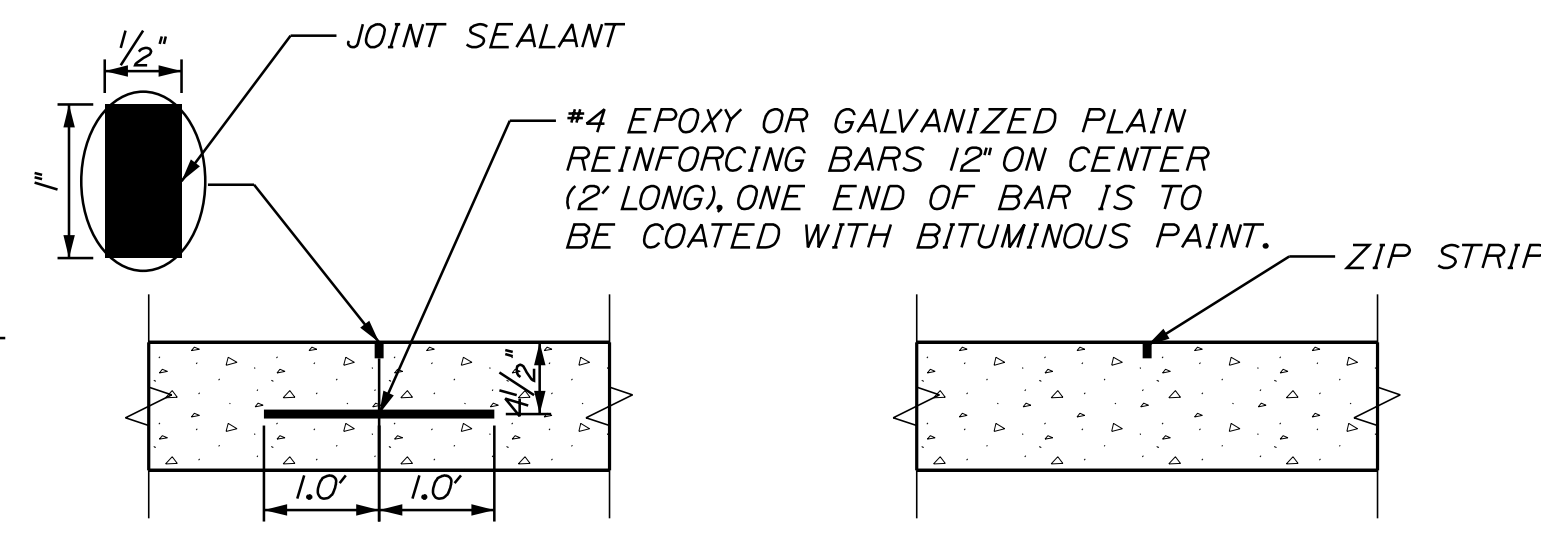

CONSTRUCTION JOINT

CONTROL JOINT

NOTES:

1. CONSTRUCT TRUCK APRON IN TWO PLACEMENTS, ALTERATING BETWEEN CONSTRUCTION JOINTS.
2. SAW CUT EXISTING PAVEMENT IN A NEAT LINE AND USE AS FORM FOR CONCRETE MEDIAN.
3. APPLY A LIGHT COAT OF TAR OR ASPHALT TO ACT AS A BOND BREAKER BETWEEN THE CONCRETE MEDIAN AND THE SUPERPAVE HOT MIX ASPHALT.
4. CONCRETE PLACEMENT PROCEDURES SHALL BE SUBJECT TO THE APPROVAL OF THE RESIDENT AND IN CONFORMANCE WITH SECTION 502.
5. FINISHED SURFACE OF MEDIAN SHALL BE BROOMED.

Date: 12/19/2021

Username: skelly

Division: HIGHWAY

Filename: ... \Sheet Sets\002\_Typicals.dgn

STATE OF MAINE  
DEPARTMENT OF TRANSPORTATION  
02379700  
WIN  
023797.00  
HIGHWAY PLANS

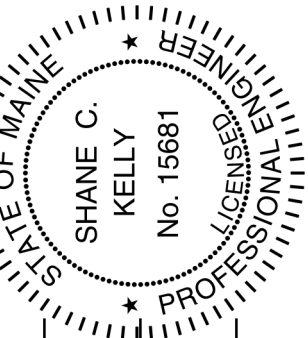

SIGNATURE  
SHANE C. KELLY  
No. 15681  
DATE  
12/09/2021

PROJ. MANAGER	E. MARTIN
DESIGN-DETAILED	S. KELLY
CHECKED-REVIEWED	B. LYON
REVISIONS 1	
REVISIONS 2	
REVISIONS 3	

WESTBROOK  
WILLIAM CLARKE DRIVE  
TYPICAL SECTIONS

SHEET NUMBER

2

OF 46

NOTE: THE ELEVATIONS OF THE ROADWAY ARE CONTROLLED THROUGH PROFILE CONTROLS LABELED. THESE PROFILE CONTROLS ARE BASED ON THE EXISTING GROUND ELEVATION AT THE SPECIFIED LOCATION.

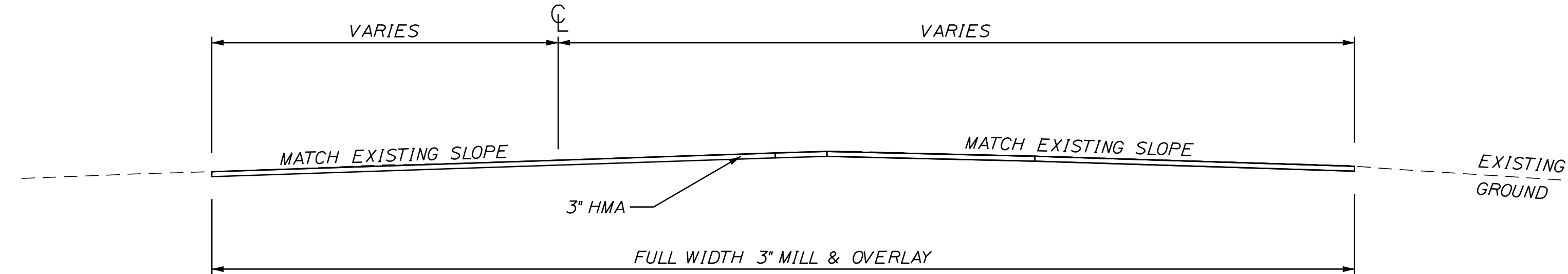

WILLIAM CLARKE DRIVE STA. 100+00 TO 104+00  
MAIN STREET STA. 300+00 TO 301+90

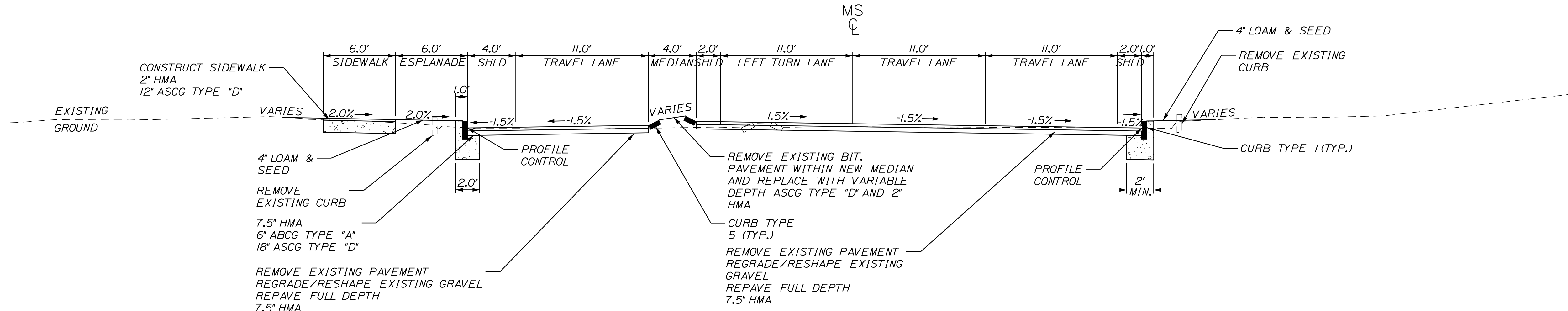

MAIN STREET STA. 301+90 TO INTERSECTION AT WILLIAM CLARKE

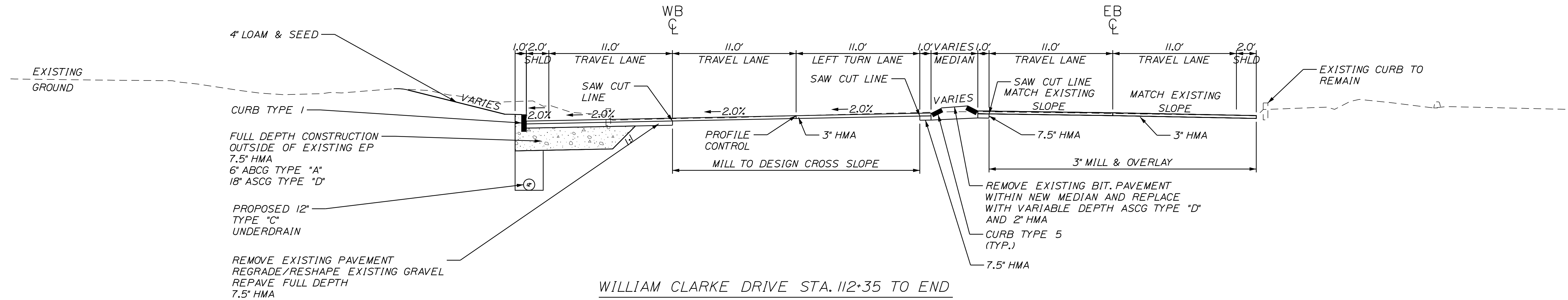

WILLIAM CLARKE DRIVE STA. 112+35 TO END

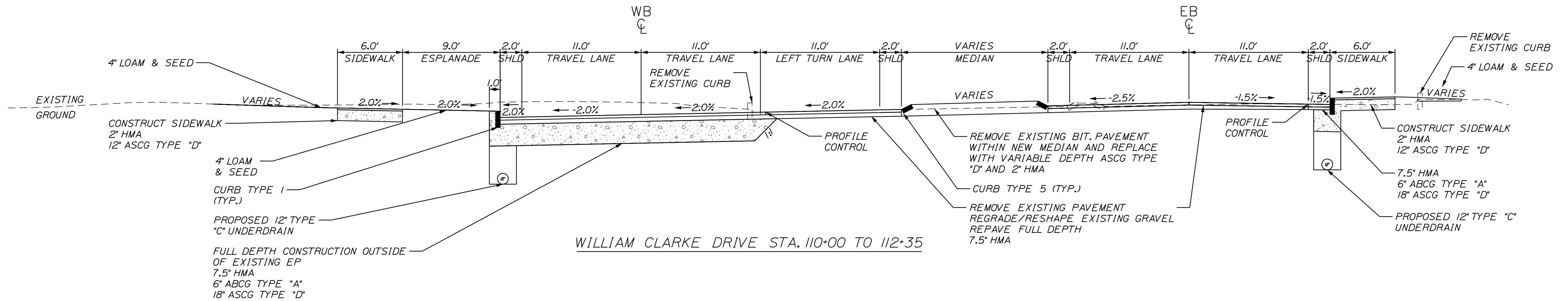

WILLIAM CLARKE DRIVE STA. 110+00 TO 112+35

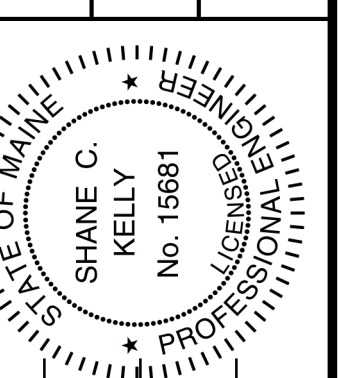

SIGNATURE: SHANE C. KELLY  
No. 15681  
P.E. NUMBER: 15681  
DATE: 12/09/2021

PROJ. MANAGER	E. MARTIN	DATE	12/09/21
DESIGN DETAILED	S. KELLY	BY	S. KELLY
CHECKED/REVIEWED	B. LYON		
REVISIONS 1			
REVISIONS 2			
REVISIONS 3			

WESTBROOK  
WILLIAM CLARKE DRIVE  
TYPICAL SECTIONS



Date: 12/19/2021

Username: skelly

Division: HIGHWAY

Filename: ... \Sheet Sets\002\_Typicals.dgn

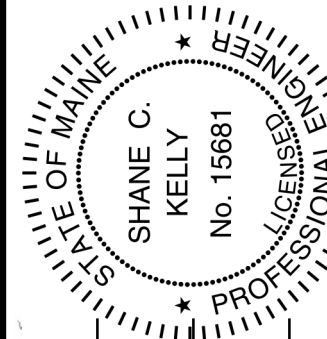
ESTIMATED QUANTITIES			
ITEM NO.	ITEM DESCRIPTION	QUANTITY	UNIT
201.23	Removing Single Tree Top Only	3	EA
201.24	Removing Stump	3	EA
202.202	Removing Pavement Surface	8565	SY
203.20	Common Excavation	2780	CY
203.25	Granular Borrow	100	CY
304.10	Aggregate Subbase Course - Gravel	1150	CY
304.14	Aggregate Base Course- Type A	255	CY
403.2081	Polymer-Modified Hot Mix Asphalt 12.5 MM Surface	1085	TONS
403.209	HMA Pavement 9.5 MM (Sidewalks, Drives, Etc.)	155	TONS
403.211	Hot Mix Asphalt - Shim	50	TONS
403.213	Hot Mix Asphalt 12.5 MM Base	2215	TONS
409.15	Bituminous Tack Coat	710	GAL
502.342	Structural Concrete Roadway Truck Apron	7	CY
603.159	12" Culvert Pipe Option III	12	LF
603.175	18" RCP Class III	72	LF
603.179	18" Culvert Pipe Option III	38	LF
604.072	Catch Basin Type A1-C	6	EA
604.092	Catch Basin Type B1-C	2	EA
604.16	Alter CB to MH	3	EA
604.18	Adjust MH or CB to Grade	13	EA
605.09	6" Underdrain Type B	288	LF
605.11	12" Underdrain Type C	580	LF
608.26	Curb Ramp Detectable Warning Field	138	SF
609.11	Vertical Curb Type 1	1425	LF
609.120	Vertical Curb Type 1 - Circular	120	LF
609.221	Terminal Curb Type 1	76	LF
609.2220	Terminal Curb Type 1 - Circular	20	LF
609.340	Curb Type 5	1820	LF
609.350	Curb Type 5 - Circular	95	LF
615.07	Loam	165	CY
618.13	Seeding Method Number 1	10	UN
618.14	Seeding Method Number 2	3	UN
619.1200	Mulch	13	UN
626.11	Precast Concrete Junction Box	10	EA
626.21	Metallic Conduit	25	LF
626.22	Non-Metallic Conduit	3275	LF
626.221	Non-Metallic Conduit, Concrete Encased	50	LF
626.251	Non-Metallic under Pavement Conduit	500	LF
626.35	Controller Cabinet Foundation	2	EA
626.421	24-inch Diameter Foundation	182	LF
626.44	36-inch Diameter Foundation	11.5	LF
626.451	42-inch Diameter Foundation	27	LF
626.47	54-inch Diameter Foundation	35	LF
626.48	60-inch Diameter Foundation	17	LF
627.733	4" White or Yellow Painted Pavement Marking Line	15300	LF
627.750	White or Yellow Pavement & Curb Marking	2450	SF
627.780	Temporary Pavement Marking Line, White or Yellow	5000	LF
629.05	Hand Labor, Straight Time	40	HR
631.12	All Purpose Excavator (Including Operator)	80	HR
631.14	Grader (including operator)	80	HR
631.15	Roller, earth and base operator	80	HR
631.172	Large Truck (Including Operator)	80	HR
631.320	Culvert Cleaner (including operator)	10	HR
634.16	Highway Lighting	1	LS
634.70	Ornamental Lighting	23	EA
639.19	Field Office Type B	1	EA
643.21	Non-Invasive Detection: Stop Line	1	LS
643.22	Non-Invasive Detection: Advance	1	LS
643.71	Traffic Signal Modification	1	LS
643.72	Temporary Traffic Signal: Saco St. Intersection	1	LS
643.72	Temporary Traffic Signal: Main St. Intersection	1	LS
643.90	Interconnect Wire Between Saco St. and Mechanic St.	745	LF
643.91	30' Mast Arm Pole	1	EA
643.92	Pedestal Pole	3	EA
643.94	Dual Purpose 50' Arm w/luminaire	3	EA
643.94	Dual Purpose 35' Arm w/luminaire	1	EA
643.94	Dual Purpose 25' Arm w/luminaire	1	EA
645.106	Demount Regulatory, Warning, Confirmation & Route Assembly Sign	12	EA
645.116	Reinstall Regulatory, Warning, Confirmation & Route Assembly Sign	5	EA
645.292	Regulatory, Warning, Confirmation & Route Assembly Signs Type II	50	SF
652.30	Flashing Arrow	4	EA
652.31	Barricade Type III	10	EA
652.33	Drum	100	EA
652.34	Cone	200	EA
652.35	Construction Sign	1000	SF
652.36	Maintenance of Traffic Control Devices	150	CD
652.38	Flagger	1500	HR
652.38	Traffic Officer with Vehicle	2500	HR
652.41	Portable Changeable Message Sign	4	EA
656.75	Temporary Soil Erosion and Water Pollution Control	1	LS
659.10	Mobilization	1	LS

STATE OF MAINE DEPARTMENT OF TRANSPORTATION		02379700	
		WIN 023797.00 HIGHWAY PLANS	
WESTBROOK WILLIAM CLARKE DRIVE ESTIMATED QUANTITIES	SHEET NUMBER  4  OF 46	DATE 12/09/21	SIGNATURE  P.E. NUMBER 15681
E. MARTIN BY S. KELLY B. LYON	PROJ. MANAGER CHECKED-REVIEWED DESIGNS-DETAILED DESIGNS-DETAILED REVISIONS 1 REVISIONS 2 REVISIONS 3 REVISIONS 4 FIELD CHANGES	DATE 12/09/21	DATE 12/09/2021



**GENERAL NOTES**

1. PAVEMENT THICKNESSES SHOWN ON THE TYPICAL SECTIONS ARE INTENDED TO BE NOMINAL.
2. GRIND TRANSITION TAPERS AT CATCH BASINS UNDER STANDARD SPECIFICATIONS ITEM 202.203, PAVEMENT BUTT JOINTS IN ACCORDANCE WITH STANDARD DETAIL 609(05), GUTTER GRADE TRANSITION AT CATCH BASIN, OR AS DIRECTED BY THE RESIDENT.
3. GRUBBING IN FILL AREAS HAS BEEN SHOWN ON THE CROSS SECTIONS AND THE QUANTITIES NOTED. THESE LIMITS ARE APPROXIMATE AND HAVE BEEN USED FOR ESTIMATING PURPOSES ONLY. ACTUAL GRUBBING LIMITS MAY VARY BASED ON FIELD CONDITIONS AS DIRECTED BY THE RESIDENT.
4. WHERE DEEMED NECESSARY BY THE RESIDENT, UNSUITABLE EXCESS MATERIAL SHALL BE REMOVED FROM THE EDGES OF SHOULDERS AND PLACED IN DESIGNATED AREAS OR DISPOSED OF. PAYMENT WILL BE MADE UNDER THE APPROPRIATE CONTRACT ITEMS.
5. ALL INSLOPE AND DITCHES IN CUT AREAS SHALL BE GRADED AS SHOWN ON THE TYPICALS OR FLATTER, OR AS DIRECTED BY THE RESIDENT.
6. THE CONTRACTOR SHALL PLAN AND CONDUCT WORK SO THAT UPON COMPLETION OF THE PROJECT THERE IS NO DROP-OFF FROM THE EDGE OF THE SHOULDER PAVEMENT.
7. THE CONTRACTOR SHALL PLACE SUITABLE EXISTING OR OTHER MATERIAL ACCEPTABLE TO THE RESIDENT ON ALL PAVEMENT EDGES TO ALLOW A DROP OFF NO GREATER THAN THE SURFACE PAVEMENT THICKNESS. THE MATERIAL SHALL BE GRADED TO MATCH THE EXISTING INSLOPE OR AS DIRECTED BY THE RESIDENT BEFORE SURFACE IS PLACED. THE CONTRACTOR WILL BE PAID UNDER APPROPRIATE EQUIPMENT RENTAL ITEMS. BORROW IS NOT AUTHORIZED UNTIL ALL ACCEPTABLE WASTE MATERIAL HAS BEEN UTILIZED. SEED AND MULCH WILL BE PAID FOR AT THE CONTRACT UNIT PRICE.
8. DRIVEWAY FILL SIDE SLOPES SHALL BE THE SAME AS THE FILL SIDE SLOPES WITHOUT GUARDRAIL UNLESS OTHERWISE NOTED ON THE PLANS.
9. ALL WASTE MATERIAL NOT USED ON THE PROJECT SHALL BE DISPOSED OF OFF THE PROJECT IN ACCEPTABLE WASTE AREAS REVIEWED BY THE RESIDENT. GRADING, SEEDING AND MULCHING OF WASTE AREAS SHALL BE CONSIDERED INCIDENTAL.
10. GRANULAR BORROW USED TO BACKFILL MUCK EXCAVATION OR IN LOW WET AREAS TO 1 FOOT ABOVE WATER LEVEL OR OLD GROUND SHALL MEET REQUIREMENTS FOR GRANULAR BORROW MATERIAL FOR UNDERWATER BACKFILL AS SPECIFIED IN STANDARD SPECIFICATIONS ITEM 703.19, GRANULAR BORROW.
11. COMMERCIAL PAVED ENTRANCES SHALL BE CONSTRUCTED WITH 3 INCHES OF HOT MIX ASPHALT AND 11 INCHES OF AGGREGATE SUBBASE COURSE GRAVEL.
12. ALL PAVED WALKS SHALL BE CONSTRUCTED WITH 12 INCHES OF AGGREGATE SUBBASE COURSE GRAVEL AND 2 INCHES OF HOT MIX ASPHALT UNLESS OTHERWISE NOTED IN THE PLANS OR DIRECTED BY THE RESIDENT.
13. ANY NECESSARY CLEANING OF EXISTING PAVEMENT PRIOR TO PAVING (OR MILLING) SHALL BE INCIDENTAL TO THE RELATED PAVING (OR MILLING) ITEMS. THIS INCLUDES KILLING AND REMOVAL OF ALL VEGETATIVE MATTER.
14. CROSS SLOPES FOR NORMAL AND SUPERELEVATED SECTIONS WILL BE STRAIGHT UNLESS OTHERWISE DIRECTED BY THE DEPARTMENT.
15. THE ALGEBRAIC DIFFERENCE BETWEEN TRAVELWAY AND SHOULDER CROSS SLOPE SHALL NOT EXCEED 8 PERCENT.
16. PRIOR TO SURFACE PAVING, EXISTING CULVERTS TO REMAIN SHALL BE CLEANED AS DIRECTED BY THE RESIDENT. PAYMENT WILL BE MADE UNDER STANDARD SPECIFICATIONS ITEM 631.32, CULVERT CLEANER (INCLUDING OPERATOR).
17. EXISTING CULVERTS AND CATCH BASINS WILL BE CLEANED AS DIRECTED BY THE RESIDENT UNDER THE APPROPRIATE PAY ITEMS.
18. NO EXISTING DRAINAGE SHALL BE ABANDONED, REMOVED OR PLUGGED WITHOUT PRIOR APPROVAL OF THE RESIDENT.
19. FLAT TOPS FOR CATCH BASINS ARE NOT ALLOWED UNLESS NOTED ON THE PLANS OR DIRECTED BY THE RESIDENT.
20. PLASTIC END CAPS SHALL BE PLACED ON THE INLET END OF ALL DEAD-END 6-INCH TYPE B UNDERDRAIN AND SHALL BE CONSIDERED INCIDENTAL TO THIS ITEM.
21. ANY NECESSARY CUTTING OF EXISTING PIPES TO FIT IN AREAS OF PROPOSED CATCH BASINS WILL NOT BE PAID FOR SEPARATELY AND WILL BE CONSIDERED INCIDENTAL TO STANDARD SPECIFICATIONS SECTION 604, MANHOLES, INLETS AND CATCH BASINS.
22. ANY NECESSARY CUTTING OF EXISTING CATCH BASINS TO ALLOW FOR PROPOSED PIPE CONNECTIONS WILL NOT BE PAID FOR SEPARATELY AND WILL BE CONSIDERED INCIDENTAL TO STANDARD SPECIFICATIONS SECTION 603, PIPE CULVERTS AND STORM DRAINS OR STANDARD SPECIFICATIONS SECTION 605, UNDERDRAINS.
23. EXISTING ABANDONED WATER MAINS BROKEN BY THE CONTRACTOR DURING CONSTRUCTION SHALL HAVE THE ENDS PLUGGED WITH BRICK AND MORTAR. COST FOR ALL LABOR AND MATERIAL WILL BE CONSIDERED INCIDENTAL TO THE CONTRACT AND NO DIRECT PAYMENT WILL BE MADE.
24. ALL TYPE A CATCH BASINS PLACED ON A TYPE 1 CIRCULAR CURB SHALL HAVE THE CURB INLET CUT AT THE SAME RADIUS AS ADJACENT CIRCULAR CURB. PAYMENT SHALL BE INCIDENTAL TO STANDARD SPECIFICATIONS SECTION 604, MANHOLES, INLETS AND CATCH BASINS.
25. LOAM HAS BEEN ESTIMATED FOR DISTURBED LAWN AREAS. ACTUAL PLACEMENT OF THE LOAM SHALL BE AS NOTED ON THE PLANS OR DESIGNATED BY THE RESIDENT.
26. UNLESS OTHERWISE NOTED SEEDING METHOD NO. 1 SHALL BE UTILIZED ON ALL LAWNS AND DEVELOPED AREAS; SEEDING METHOD NO. 2 SHALL BE UTILIZED ON ALL OTHER AREAS.
27. LOAM SHALL BE PLACED TO A NOMINAL DEPTH OF 4 INCHES IN LAWN AREAS AND 2 INCHES IN ALL OTHER AREAS UNLESS OTHERWISE NOTED OR DIRECTED.

28. ANY BASE PAVEMENT NOT SURFACED BEFORE WINTER WILL REQUIRE TEMPORARY PAVEMENT MARKINGS OF PAINT, BOTH YELLOW CENTERLINE AND WHITE EDGE LINES AND WILL BE CONSIDERED PART OF STANDARD SPECIFICATIONS ITEM 627.78, TEMPORARY PAVEMENT MARKING LINE, WHITE OR YELLOW.
29. THE CONTRACTOR WILL BE RESPONSIBLE FOR MAINTAINING ALL EXISTING MAILBOXES TO ENSURE THAT THE MAIL WILL BE DELIVERABLE. PAYMENT FOR THIS WORK WILL BE CONSIDERED INCIDENTAL TO THE CONTRACT
30. THE CONTRACTOR WILL BE RESPONSIBLE FOR MAINTAINING ALL EXISTING OPERATIONAL BUSINESS DIRECTIONAL SIGNS (OBDS) TO ENSURE THAT THEY ARE VISIBLE TO THE TRAVELING PUBLIC. PAYMENT FOR THIS WORK WILL BE CONSIDERED INCIDENTAL TO THE CONTRACT.
31. THE CONTRACTOR IS RESPONSIBLE FOR THE CAREFUL SIDE STAKING OF EXISTING CENTERLINE AS PER STANDARD SPECIFICATION SECTION 105.6.2, CONTRACTOR PROVIDED SERVICES. SIDE STAKES SHALL BE PLACED SAFELY OUTSIDE OF THE CONSTRUCTION LIMITS AND THE EXISTING CENTERLINE GRADES SHALL BE TRANSFERRED TO THESE STAKES. THESE STAKES AND GRADES WILL BE USED TO LAY OUT CENTERLINE AND DETERMINE NEW CONSTRUCTION FINISH GRADES FROM DIFFERENTIAL ELEVATION SHEETS FURNISHED BY MAINEDOT. ALL LAYOUT, STAKES, AND GRADES WILL BE CHECKED AND MUST BE ACCEPTABLE TO THE RESIDENT.
32. ANY DAMAGE TO THE SLOPES CAUSED BY THE CONTRACTOR'S EQUIPMENT, PERSONNEL, OR OPERATION SHALL BE REPAIRED TO THE SATISFACTION OF THE RESIDENT. ALL WORK, EQUIPMENT, AND MATERIALS REQUIRED TO MAKE REPAIRS SHALL BE AT THE CONTRACTOR'S EXPENSE.
33. GEOTECHNICAL INFORMATION FURNISHED OR REFERRED TO IN THE BID DOCUMENTS IS FOR THE USE OF THE BIDDERS. NO ASSURANCE IS GIVEN THAT THE INFORMATION OR INTERPRETATIONS WILL BE REPRESENTATIVE OF THE ACTUAL SUBSURFACE CONDITIONS THROUGHOUT THE CONSTRUCTION SITE. MAINEDOT WILL NOT BE RESPONSIBLE FOR ANY INTERPRETATIONS OR CONCLUSIONS DRAWN FROM THE GEOTECHNICAL INFORMATION. THE BORING LOGS PROVIDED IN THE BID DOCUMENTS (IF ANY) PRESENT FACTUAL AND INTERPRETIVE SUBSURFACE INFORMATION COLLECTED AT DISCRETE LOCATIONS. DATA PROVIDED MAY NOT BE REPRESENTATIVE OF THE SUBSURFACE CONDITIONS BETWEEN BORING LOCATIONS.
34. AREAS ON THE PROJECT REQUIRING FILL WILL COME FROM SUITABLE SITES SUCH AS EXCAVATION, DITCH AND INSLOPE OR EQUIPMENT RENTAL AREAS.
35. NO SEPARATE PAYMENT FOR SUPERINTENDENT OR FOREMAN WILL BE MADE FOR THE SUPERVISION OF EQUIPMENT AND LAYOUT OF WORK BEING PAID FOR UNDER THE EQUIPMENT RENTAL ITEMS.
36. UNDETERMINED LOCATIONS SHALL BE DETERMINED BY THE RESIDENT.
37. STATIONS REFERENCED ARE APPROXIMATE.
38. FINAL STRIPING FOR THE PROJECT SHALL BE DONE BY THE CONTRACTOR PER THE STRIPING LAYOUT IN THE CONTRACT DOCUMENTS OR AS PROVIDED BY THE DEPARTMENT. PAYMENT SHALL BE MADE UNDER APPROPRIATE CONTRACT ITEMS.
39. THE CONTRACTOR WILL PLACE APPROPRIATELY-MARKED STAKES AT THE FOLLOWING LOCATIONS ON THE PROJECT: STRIPING PATTERN CHANGES, CROSS-SLOPE CHANGES, AND EVERY 500 FEET FOR STATIONING. THE CONTRACTOR WILL PAINT EVERY FULL STATION (100 FEET) ON THE EXISTING ROADWAY AND WILL TRANSFER THE PAINTED STATIONING THROUGH ALL INTERMEDIATE LIFTS (NOT SURFACE). APPROPRIATELY-SIZED STRIPING PATTERN CHANGES WILL BE PAINTED ON SURFACE. STATIONING CONTROL MUST BE PLACED BEFORE WORK CAN COMMENCE. CROSS-SLOPE AND STRIPING CHANGE CONTROLS MUST BE PLACED BEFORE PAVING CAN COMMENCE.
40. ALL HMA FOR PATCHING AROUND ADJUSTED, ALTERED, OR REBUILT UTILITY STRUCTURES SHALL BE A 9.5 MM OR 12.5 MM MAINEDOT APPROVED MIX DESIGN. EXCLUDING WATER AND GAS GATE VALVES, THE CONTRACTOR SHALL SAW CUT THE EXISTING PAVEMENT FOR THE PATCH AT LEAST TWO FEET AWAY FROM THE NEAREST EDGE OF THE STRUCTURE. THE CONTRACTOR SHALL PLACE HMA IN LIFTS OF 2 INCHES OR LESS, AS DIRECTED BY THE RESIDENT, AND COMPACT THE HMA USING A MINIMUM OF A 150-POUND PLATE COMPACTOR. HMA FOR PATCHING AROUND ADJUSTED, ALTERED, OR REBUILT UTILITY STRUCTURES IS CONSIDERED INCIDENTAL TO THE RESPECTIVE PAY ITEM FOR ADJUST, ALTER, OR REBUILD UTILITY STRUCTURE.
41. OFFSETS TO CATCH BASINS, WHERE APPLICABLE, ARE PROVIDED TO THE PROPOSED CURB LINE. RIM ELEVATIONS ARE PROVIDED AT THE GUTTER GRADE AND ACCOUNT FOR THE NECESSARY DEPRESSIONS.

Date: 12/19/2021

Username: skelly

Division: HIGHWAY

Filename: ... \006\_GeneralNotes.dgn

STATE OF MAINE  
DEPARTMENT OF TRANSPORTATION  
02379700  
WIN  
023797.00  
HIGHWAY PLANS

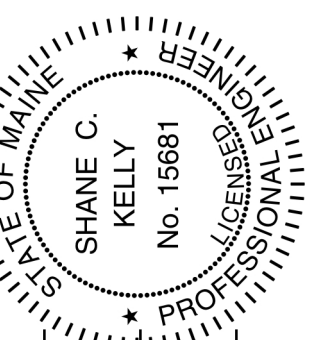

SIGNATURE: SHANE C. KELLY  
P.E. NUMBER: 15681  
DATE: 12/09/2021

PROJ. MANAGER	E. MARTIN	BY	S. KELLY B. BYON	DATE	12/09/21 12/09/21
DESIGN-DETAILED	CHECKED-REVIEWED	DESIGNS-DETAILED	DESIGNS-DETAILED	REVISIONS 1	REVISIONS 2
REVISIONS 3	REVISIONS 4	FIELD CHANGES			

WESTBROOK  
WILLIAM CLARKE DRIVE  
GENERAL NOTES

SHEET NUMBER  
6  
OF 46

Date: 12/8/2021

Username: Kate.Maguire

Filename: ... \00\GEOTECH\MSTAN004\_BLP1.dgn Division: GEOTECH

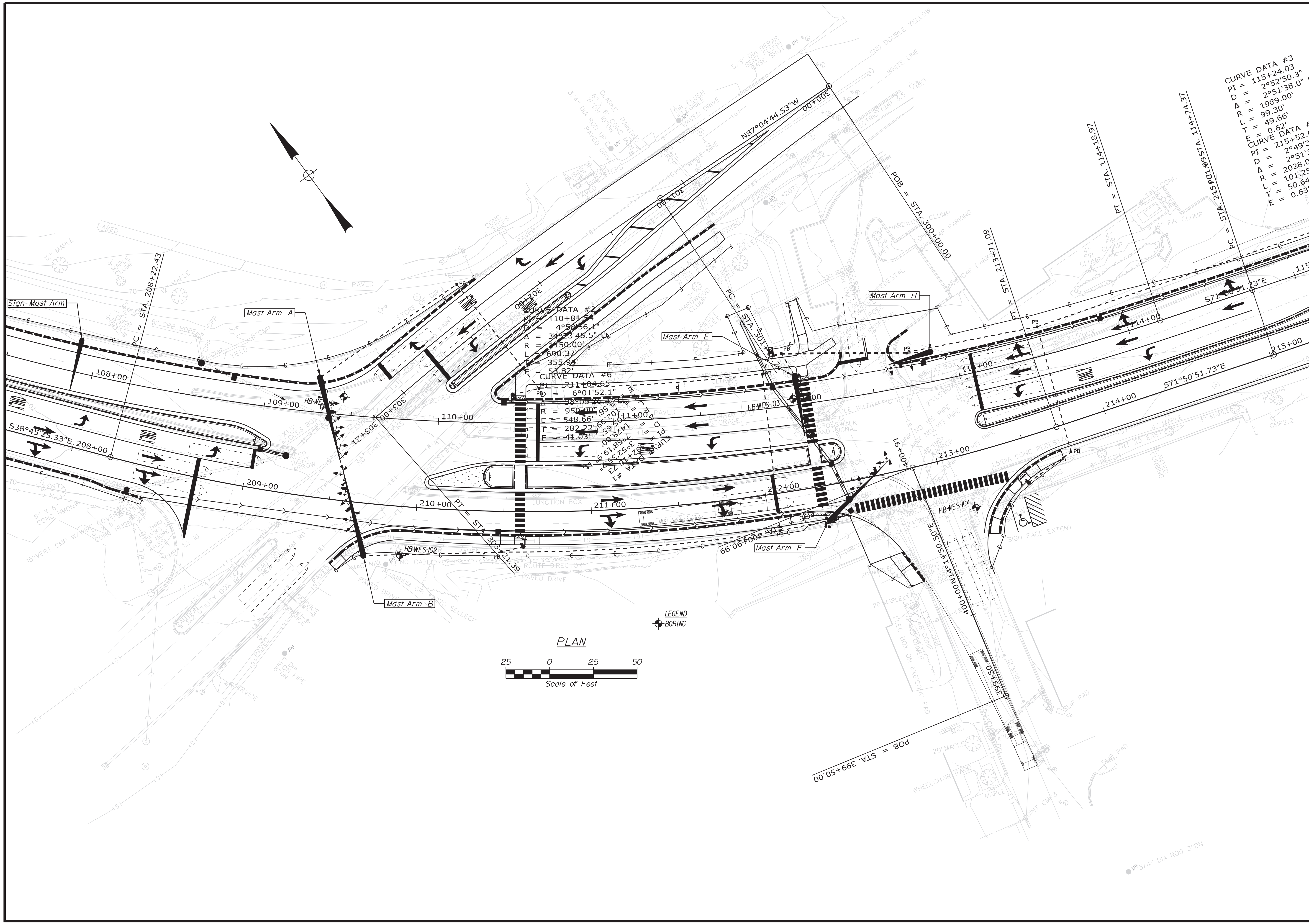

STATE OF MAINE  
 DEPARTMENT OF TRANSPORTATION  
 PROJECT NUMBER: 2379700  
 WIN: 023797.00  
 HIGHWAY PLANS

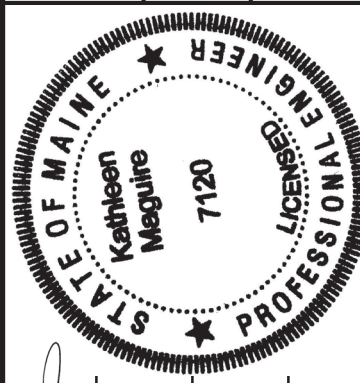

PROJ. MANAGER	BY	DATE
CHECKED/REVIEWED	T. WHITE	NOV 2021
DESIGN/DET. AILED		
DESIGN/DET. AILED		
REVISIONS 1		
REVISIONS 2		
REVISIONS 3		
REVISIONS 4		
FIELD CHANGES		

WESTBROCK CLARKE DRIVE  
 BORING LOCATION PLAN

SHEET NUMBER  
 7  
 OF 46

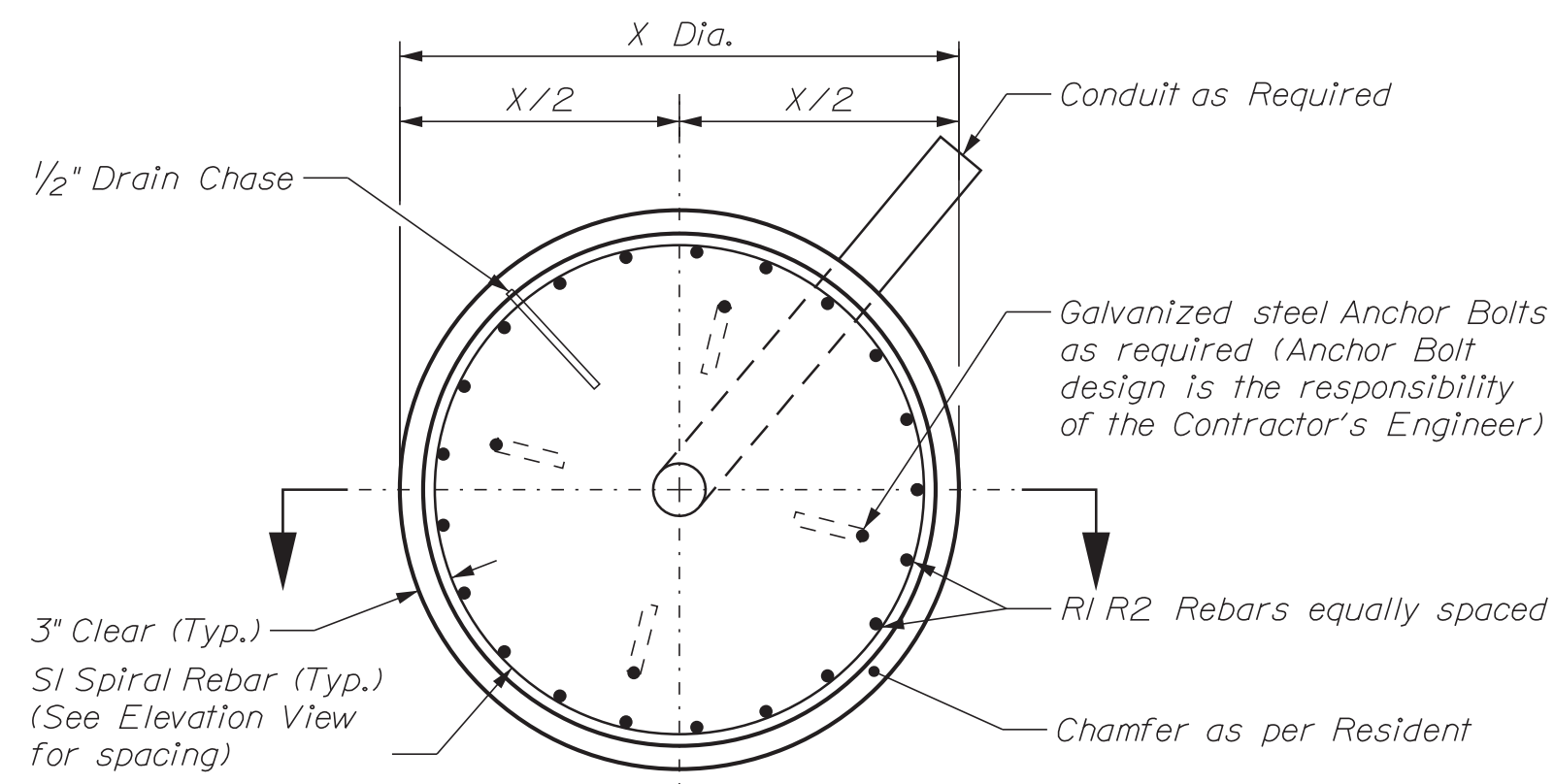

Drilled Shaft Plan View

Not to Scale (See Table for Drilled Shaft & Reinforcement Information)

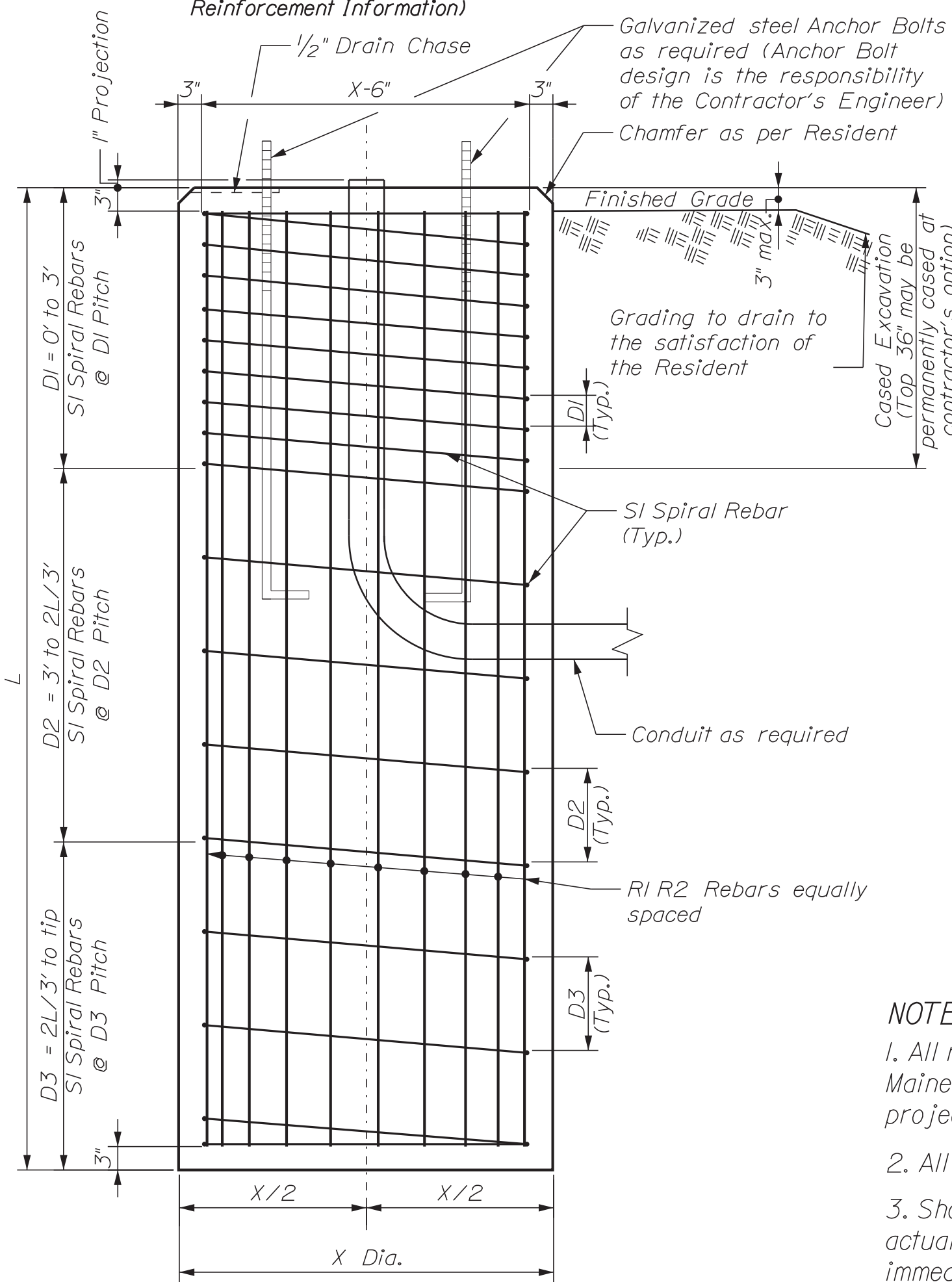

Drilled Shaft Elevation View

Not to Scale (See Table for Drilled Shaft & Reinforcement Information)

MAST ARM SIGN, A, B, E, F & H

NOTES:

1. All reinforcing steel is to be grade 60 and conform to MaineDOT Standard Specification requirements along with any project specific Supplementals or Special Provisions.
2. All rebar shall have 3" cover unless otherwise noted.
3. Should there be a discrepancy between these Details and actual observed field conditions report it to the Resident immediately.
4. Do not proceed with dependent work until any such discrepancy is resolved to the satisfaction of the Resident.
5. Concrete to be Class LP with  $f'c = 5,000$  PSI.

Mast Arm Designation	Mast Arm Station and Offset	Drilled Shaft Dimensions		Reinforcing Steel			Spiral Bar Spacing		
		Diameter (feet)	Length (feet)	R1 Longitudinal Rebars Quantity	R2 Longitudinal Rebars Size	S1 Spiral Rebars Size	D1 (in) 0 to 3 ft	D2 (in) 3 ft to 2L/3 ft	D3 (in) 2L/3 ft to tip
Sign Mast Arm, 30' long	107+89.8, 18.6' LT	3.0	11.5	15	#8	#5	4	8	12
Signal Mast Arm A, 50' long	109+30.06, 19.9' LT	5.0	17.0	27	#10	#5	4	12	12
Signal Mast Arm B, 50' long	209+72.50, 29.9' RT	4.5	17.0	24	#10	#5	4	12	12
Signal Mast Arm E, 35' long	112+06.34, 16.7' LT	3.5	16.0	18	#9	#5	4	4	12
Signal Mast Arm F, 50' long	212+33.50, 20.0' RT	4.5	18.0	24	#10	#5	4	12	12
Signal Mast Arm H, 25' long	112+86.40, 16.9' LT	3.5	11.0	18	#9	#5	4	4	12

Maine Department of Transportation Soil/Rock Exploration Log US CUSTOMARY UNITS				Project: Route 25 Location: Westbrook, Maine		Boring No.: HB-WES-101 WIN: 23797.00	
Driller: MainDOT	Elevation (ft.): 68.5	Auger ID/OD: 5" Solid Stem					
Operator: Duggan	Soil/Type: NAD98	Sampler: Standard Split Spoon					
Logged By: B. W. Ider	Rig Type: CME 45C	Header Mt./Fall: 140W/30"					
Date Start/Finish: 8/31/2020-9/1/2020	Drilling Method: Cased Wash Boring	Core Barrel: N/A					
Boring Location: 109+44.8, 10.4 ft. LT.	Casing ID/OD: NK-3"	Water Level: N/A					
Hammer Efficiency Factors 0.89 Hammer Type: Automatic Hydraulic: <input checked="" type="checkbox"/> Rope & Cathead: <input type="checkbox"/> Penetration: <input type="checkbox"/>							
Penetration Test: <input type="checkbox"/> Blow Count: <input type="checkbox"/> Blow Energy: <input type="checkbox"/> Blow Rate: <input type="checkbox"/> Blow Count: <input type="checkbox"/> Blow Energy: <input type="checkbox"/> Blow Rate: <input type="checkbox"/>							
Laboratory Testing Results: <input type="checkbox"/> Moisture: <input type="checkbox"/> Specific Gravity: <input type="checkbox"/> Liquid Limit: <input type="checkbox"/> Plastic Limit: <input type="checkbox"/> Plasticity Index: <input type="checkbox"/>							
Visual Description and Remarks: 2" HMA on Traffic Island. Light brown, damp, medium dense, fine to coarse SAND, little gravel, trace silt, (F111). Brown, wet, loose, fine to coarse SAND, little silt. HP = Hydraulic Push (S3) Grey, wet, very soft, Clayey SILT, trace fine sand. Similar to above. Casing same to 15.5 ft bgs while washing. S5x10 mm vane vane readings: V1 14.0/1.5 ft-lbs V2 13.0/1.0 ft-lbs							

Maine Department of Transportation Soil/Rock Exploration Log US CUSTOMARY UNITS				Project: Route 25 Location: Westbrook, Maine		Boring No.: HB-WES-103 WIN: 23797.00	
Driller: MainDOT	Elevation (ft.): 67.7	Auger ID/OD: 5" Solid Stem					
Operator: Duggan	Soil/Type: NAD98	Sampler: Standard Split Spoon					
Logged By: B. W. Ider	Rig Type: CME 45C	Header Mt./Fall: 140W/30"					
Date Start/Finish: 9/1/2020-12/10/2020	Drilling Method: Cased Wash Boring	Core Barrel: N/A					
Boring Location: 112+03.6, 3.1 ft. FT. LT.	Casing ID/OD: NK-3"	Water Level: N/A					
Hammer Efficiency Factors 0.89 Hammer Type: Automatic Hydraulic: <input checked="" type="checkbox"/> Rope & Cathead: <input type="checkbox"/> Penetration: <input type="checkbox"/>							
Penetration Test: <input type="checkbox"/>							
Visual Description and Remarks: 1.5" HMA on Sidewalk. Olive, moist, stiff, Clayey SILT, little fine sand. Light brown, moist, loose, fine to medium SAND, trace silt. Similar to above, except wet. Grey, wet, very loose, Silty fine SAND, some clay. Similar to above. Bottom of Exploration at 22.0 feet below ground surface. NO REFUSAL.							

Maine Department of Transportation Soil/Rock Exploration Log US CUSTOMARY UNITS				Project: Route 25 Location: Westbrook, Maine		Boring No.: HB-WES-102 WIN: 23797.00	
Driller: MainDOT	Elevation (ft.): 69.7	Auger ID/OD: 5" Solid Stem					
Operator: Duggan	Soil/Type: NAD98	Sampler: Standard Split Spoon					
Logged By: B. W. Ider	Rig Type: CME 45C	Header Mt./Fall: 140W/30"					
Date Start/Finish: 9/1/2020-09/01/2020	Drilling Method: Cased Wash Boring	Core Barrel: N/A					
Boring Location: 209+92.5, 27.8 ft. FT. RT.	Casing ID/OD: NK-3"	Water Level: None Observed					
Hammer Efficiency Factors 0.89 Hammer Type: Automatic Hydraulic: <input checked="" type="checkbox"/> Rope & Cathead: <input type="checkbox"/> Penetration: <input type="checkbox"/>							
Penetration Test: <input type="checkbox"/>							
Visual Description and Remarks: 2" Grass and Sap. (S3) Brown, damp, loose, fine to coarse SAND, little silt. Olive, wet, very soft, Clayey SILT, trace fine sand. HP = Hydraulic Push (S3) Grey, wet, very loose, Silty fine SAND, some clay. S5x10 mm vane vane readings: V1 14.0/1.5 ft-lbs V2 20.0/4.5 ft-lbs							

Maine Department of Transportation Soil/Rock Exploration Log US CUSTOMARY UNITS				Project: Route 25 Location: Westbrook, Maine		Boring No.: HB-WES-104 WIN: 23797.00	
Driller: MainDOT	Elevation (ft.): 66.7	Auger ID/OD: 5" BTD					
Operator: Duggan	Soil/Type: NAD98	Sampler: Standard Split Spoon					
Logged By: B. W. Ider	Rig Type: CME 45C	Header Mt./Fall: 140W/30"					
Date Start/Finish: 8/31/2020-9/1/2020	Drilling Method: Solid Stem Auger	Core Barrel: N/A					
Boring Location: 213+4.7, 31.1 ft. FT. RT.	Casing ID/OD: N/A	Water Level: 10.0 ft bgs.					
Hammer Efficiency Factors 0.89 Hammer Type: Automatic Hydraulic: <input checked="" type="checkbox"/> Rope & Cathead: <input type="checkbox"/> Penetration: <input type="checkbox"/>							
Penetration Test: <input type="checkbox"/>							
Visual Description and Remarks: 2" HMA on Sidewalk. Brown, moist, loose, fine to coarse SAND, some gravel, little silt, (F111). Light brown, moist, loose, fine to medium SAND, trace clay. Light brown, wet, medium dense, fine to medium SAND, trace silt. Light brown, moist, medium dense, fine to medium SAND, trace silt. Grey, wet, loose, fine to medium SAND, little silt. Bottom of Exploration at 22.0 feet below ground surface. NO REFUSAL.							

STATE OF MAINE  
DEPARTMENT OF TRANSPORTATION  
2379700  
WIN 023797.00  
HIGHWAY PLANS

STATE OF MAINE  
Kathleen Maguire  
7120  
PROFESSIONAL ENGINEER

DATE: 12/18/2021  
SIGNATURE: T. WHITE  
P.E. NUMBER: 7120  
DATE: 12/18/2021

DESIGN-CHECKED: K. MAGUIRE  
DESIGN-REVIEWED: T. WHITE  
DESIGN-DATE: 12/18/2021  
DESIGN-REVISIONS: 1  
DESIGN-REVISIONS: 2  
DESIGN-REVISIONS: 3  
DESIGN-REVISIONS: 4

WESTBROOK CLARKE DRIVE  
MAST ARM FOUNDATIONS WITH BORING LOGS

SHEET NUMBER 8 OF 46

Date:12/19/2021

Username: skelly

Division: HIGHWAY

Filename: ... \Sheets\009\_SignalNotes.dgn

TRAFFIC SIGNAL GENERAL NOTES

- PRIOR TO ANY CONSTRUCTION, DIG SAFE MUST BE NOTIFIED AND A SITE IDENTIFICATION NUMBER ALONG WITH A SAFE TO DIG DATE OBTAINED. THE CONTRACTOR SHALL BE RESPONSIBLE FOR FIELD VERIFYING THE LOCATION, DEPTH, AND MATERIAL OF ALL SUBSURFACE UTILITY LINES LOCATED WITHIN THE CONSTRUCTION AREA.
- THE CONTRACTOR IS SPECIFICALLY CAUTIONED THAT EXISTING UTILITY LOCATIONS AND/OR ELEVATIONS ARE APPROXIMATE. THE CONTRACTOR IS HEREBY CAUTIONED THAT ALL EXISTING SUBSURFACE LINES AND STRUCTURES MAY NOT BE SHOWN. THE INFORMATION IS NOT TO BE RELIED ON AS BEING EXACT OR COMPLETE. THE CONTRACTOR SHALL CONTACT DIG SAFE AT LEAST THREE (3) BUT NOT MORE THAN THIRTY (30) DAYS PRIOR TO COMMENCEMENT OF EXCAVATION OR DEMOLITION. THE CONTRACTOR SHALL BE RESPONSIBLE FOR COMPLIANCE WITH THE REQUIREMENTS OF THE MAINE "DIG SAFE LAW" CHAPTER 718, ENACTED ON 8-11-00. CONTRACTOR SHALL TAKE NOTICE OF THE FOLLOWING RULES:
  - ENFORCEMENT - THE ADMINISTRATIVE PENALTY FOR VIOLATION OF MAINE DIG SAFE LAW IS AS FIRST OFFENSE = \$500.00 SUBSEQUENT OFFENCES WITHIN 12 MONTHS) = \$5,000.00

THE PUC MAY ALSO REQUIRE A PERSON WHO VIOLATES THE MAINE DIG SAFE LAW TO PARTICIPATE, AT THE EXPENSE OF THE VIOLATOR, IN AN EDUCATIONAL PROGRAM DEVELOPED AND CONDUCTED BY DIG SAFE SYSTEM, INC.

  - EXCAVATION METHODS - IF EXCAVATING WITHIN 18 INCHES OF ANY MARKED UNDERGROUND FACILITY, AN EXCAVATOR MAY NOT USE MECHANICAL MEANS OF EXCAVATION (THE USE OF ANY DEVICE OR TOOL POWERED BY AN ENGINE) UNTIL THE UNDERGROUND FACILITY IS EXPOSED.

EXCEPTIONS: THIS RULE DOES NOT APPLY IF USING AIR VACUUM METHODS OF EXCAVATION. MECHANICAL MEANS MAY BE USED FOR INITIAL PENETRATION OR REMOVAL OF PAVEMENT, ROCK OR OTHER MATERIAL REQUIRING MACHINERY.

EMERGENCIES: PREVIOUSLY, AN EXCAVATOR WAS NOT REQUIRED TO NOTIFY DIG SAFE PRIOR TO ANY EMERGENCY EXCAVATION. NOW IN AN EMERGENCY SITUATION, AN EXCAVATOR MAY COMMENCE EXCAVATION AFTER HAVING TAKEN ALL REASONABLE STEPS CONSISTENT WITH THE EMERGENCY AND PREMARK THE AREA AS SOON AS POSSIBLE AFTER RECEIVING NOTIFICATION OF THE EMERGENCY.
- CONTRACTOR SHALL BE RESPONSIBLE FOR OBTAINING ANY NECESSARY STREET/SIDEWALK OCCUPANCY OR OPENING PERMITS
- TRAFFIC SIGNAL WORK SHALL BE COMPLETED IN SUCH A MANNER THAT WILL CAUSE THE MINIMUM DISRUPTION TO TRAFFIC.
- STATIONS REFERENCED ARE APPROXIMATE.
- THE CONTRACTOR SHALL MEET ALL UTILITY REQUIREMENTS FOR NEW SERVICE CONNECTIONS. THE TRAFFIC SIGNAL ELECTRICAL METER SHALL BE EQUIPPED WITH A GENERLINK METER COLLAR MODEL MA 23/24-N/S TO ENABLE CONNECTION TO A PORTABLE GENERATOR.
- ONE COPY OF AS-BUILT PLANS WITH TRAFFIC SIGNAL TIMINGS, WIRING DIAGRAMS, BOX PRINTS, AND EQUIPMENT MANUALS SHALL BE LEFT IN THE CONTROLLER CABINET.
- ALL MATERIAL SCHEDULES SHOWN ON THE PLANS ARE FOR GENERAL INFORMATION ONLY. THE CONTRACTOR SHALL PREPARE THEIR OWN MATERIAL SCHEDULES BASED ON THEIR PLAN REVIEW. ALL SCHEDULES SHALL BE VERIFIED IN THE FIELD BY THE CONTRACTOR PRIOR TO ORDERING MATERIALS OR PERFORMING WORK.
- THE LOCATIONS OF ALL EQUIPMENT ARE APPROXIMATE. FINAL LOCATIONS SHALL BE DETERMINED IN THE FIELD BY THE ENGINEER AND/OR RESIDENT.
- THE CONTRACTOR SHALL BE SOLELY RESPONSIBLE FOR FURNISHING AND INSTALLING ALL OTHER EQUIPMENT NECESSARY FOR A COMPLETE AND OPERATIONAL SIGNAL SYSTEM.
- MAINEDOT SHALL HAVE FIRST RIGHTS TO ALL EQUIPMENT REMOVED OR REPLACED BY THE PROJECT. THE CITY OF WESTBROOK SHALL HAVE SECOND SALVAGE RIGHTS TO ALL EQUIPMENT NOT CLAIMED BY MAINEDOT. MAINEDOT WILL SUBMIT A LIST OF SALVAGED MATERIAL TO BE DELIVERED TO THE ELECTRICAL SHOP. LIKEWISE CONTRACTOR SHALL DELIVER REQUESTED SALVAGED MATERIAL TO THE CITY OF WESTBROOK. THE CONTRACTOR SHALL CAREFULLY REMOVE AND STORED ALL EQUIPMENT CLAIMED BY EITHER MAINEDOT OR THE CITY OF WESTBROOK AT A CENTRAL LOCATION ON SITE PRIOR TO DELIVERY. THE STORAGE AREA SHALL BE SECURE AND ALL CONTROL EQUIPMENT REMOVED THAT HAS COMPUTER CHIP TECHNOLOGY SHALL BE STORE IN AN INTERIOR HEATED ENVIRONMENT.
 

ANY EQUIPMENT NOT CLAIMED BY EITHER MAINEDOT OR THE CITY OF WESTBROOK SHALL BE REMOVED FROM THE SITE BY THE CONTRACTOR AND DISPOSED OF IN A MANNER ACCEPTABLE TO THE ENGINEER.
- THE CONTRACTOR IS DIRECTED TO PROJECT SPECIAL PROVISION 718 FOR ADDITIONAL INFORMATION RELATED TO THE FOLLOWING:
  - 718.07 CONTROLLERS
  - 718.08 CONTROLLER CABINET

SPECIAL PROVISION 718 EXPANDS UPON THE INFORMATION FOUND IN THESE GENERAL NOTES. AS SUCH, THE MORE RESTRICTIVE LANGUAGE BETWEEN THESE GENERAL NOTES AND SPECIAL PROVISION 718 SHALL GOVERN THE WORK TO BE PERFORMED UNDER THIS PROJECT.

SIGNAL HEADS / MOUNTING

- SHALL BE ONE-WAY, 12" DIAMETER, WITH LED LENSES.
- SHALL HAVE 5" BLACK LOUVERED BACKPLATES AND 3" RETRO-REFLECTIVE BORDERS.
- SHALL BE EQUIPPED WITH TUNNEL VISORS.
- SHALL BE MOSS GREEN POLYCARBONATE WITH BLACK FACES.
- SHALL BE FIX MOUNTED TO MAST ARMS WITH ASTRO-BRACKETS.
- THE BOTTOM OF ALL SIGNAL HEAD HOUSINGS SHALL BE A MINIMUM OF 17 FEET BUT NOT MORE THAN 19 FEET ABOVE THE ROADWAY.
- SIGNALS TO OPERATE WITH COLORS AT ALL TIMES.
- SIGNALS TO OPERATE IN FLASH MODE FOR EMERGENCIES ONLY. SIGNALS SHALL BE ALL RED FOR 3 SECONDS AFTER CONFLICT FLASH.

MAST ARMS / TRAFFIC STRUCTURES

- ALL POLES, MAST ARMS, MOUNTING HARDWARE, VEHICULAR SIGNAL HOUSINGS, CONTROLLER CABINET WITH EXTENSION BASES, PUSH BUTTON ASSEMBLIES AND OTHER EXTERNAL ITEMS SHALL BE HOT DIPPED GALVANIZED STEEL AND SHALL BE POLYESTER POWDER COAT PAINT FINISH (RAL6005) MOSS GREEN
- ALL EQUIPMENT POLES, HAND HOLES, CONDUIT AND CONTROLLER SHALL BE PROTECTED AGAINST RODENTS. PEDESTRIAN POLES SHALL BE ONE PIECE CONSTRUCTED (BASE AND POLE) EXCEPT WHEN INSTALLED ON THE TOP OF A PEDESTRIAN POLE IN THIS CASE THE BOTTOM SECTION OF A THREE OR FOUR SECTION SIGNAL SHALL BE ALUMINUM IF NOT THE ENTIRE SIGNAL WITHOUT A THREADED NIPPLE BETWEEN SLIP FITTER AND SIGNAL HOUSING.
- ALL JUNCTION BOX COVERS SHOWN ON THE PLANS SHALL BE LABELED "TRAFFIC".

INTERCONNECT NOTES

- THE PROPOSED SIGNAL INTERCONNECT SHALL BE 12 STRAND SINGLE-MODE FIBER OPTIC INTERCONNECT CABLE
- FUSION SPLICES SHALL BE USED IN ALL LOCATIONS. NO MECHANICAL SPLICES SHALL BE ALLOWED. THE FUSION SPLICER SHALL HAVE AUTOMATIC CORE ALIGNMENT IN THE HORIZONTAL AND VERTICAL PLANES. IT SHALL BE CAPABLE OF SPLICES WITH A TYPICAL LOSS OF 0.02DB FOR SINGLE-MODE FIBER AND IT SHALL BE CAPABLE OF ESTIMATING THE SPLICE LOSS.
- FIBER OPTIC CABLE SHALL BE FULLY COMPATIBLE WITH THE EXISTING SERVICE PROVIDER'S INFRASTRUCTURE.
- FIBER OPTIC CABLE SHALL HAVE THE FOLLOWING FEATURES:
  - \*ALL DIALECTRIC (NON-ARMORED)
  - \*DIALECTRIC CENTRAL AND OUTER STRENGTH MEMBERS
  - \*RIPCORD FOR EASY STRIPPING
  - \*COLOR-CODED FIBERS AND BUFFER TUBES FOR EASY IDENTIFICATION
  - \*RATED FOR OUTDOOR USE
  - \*DRY CABLE WITH WATER-BLOCKING DESIGN. GEL-FILLED CABLE SHALL NOT BE ALLOWED.
  - \*STORAGE AND OPERATING TEMPERATURE OF -40 DEGREES TO 70 DEGREES C (-40 DEGREES TO 158 DEGREES F)
  - \*9/125 TYPE SINGLE-MODE CABLE WITH 9UM CORE, 125UM CLAD, AND 245 UM CORING
  - \*MAXIMUM ATTENUATION OF 0.35 DB PER KM FOR 1310NM, 0.35 DB PER KM FOR 1383NM AND 0.25 DB PER KM FOR 1550 NM
  - \*SERIAL GIGABIT ETHERNET DISTANCE OF 5000M FOR 1310 NM
  - \*SERIAL 10 GIGABIT ETHERNET DISTANCE OF 10000M FOR 1310NM AND 40000 FOR 550 NM
  - \*SINGLE-MODE FIBERS SHALL COMPLY WITH EIA/TIA-492CAA AND ITU RECOMMENDATION G.652
- CONTRACTOR SHALL LEAVE 15' OF CABLE SLACK IN THE TRAFFIC CONTROL CABINETS
- THE FIBER OPTIC CABLE SHALL BE TERMINATED IN THE PATCH PANNELS AND TWO STRANDS SHALL BE CONNECTED TO THE PROPOSED ETHERNET ELECTRICAL TO OPTICAL MEDIA CONVERTERS THROUGH SFP OPTICAL MODULES.

DETECTION

- THE CONTRACTOR SHALL FURNISH AND INSTALL NON-INVASIVE STOP LINE AND ADVANCE VEHICLE DETECTION AS SHOWN IN THE PLANS. THE VEHICLE DETECTORS ARE TO BE CONNECTED TO THE INTERSECTION TRAFFIC CONTROLLER FOR LOCAL VEHICLE DETECTION AND REMOTELY CONNECTED TO THE PACTS RTMS SERVER TO ALLOW VISUAL CONFIRMATION AND ADJUSTMENT OF THE DETECTION ZONES AS SHOWN IN THE PLANS. WORK SHALL BE CONSTRUCTED AND PAID FOR AS OUTLINED IN SPECIAL PROVISION 643.
- STOP LINE VEHICLE DETECTION SHALL BE CAPABLE OF COUNTING VEHICLE VOLUMES FOR EACH MOVEMENT. VEHICLE VOLUMES SHALL BE ABLE TO BE DOWNLOADED FROM EITHER THE VEHICLE DETECTION PROCESSOR OR THE TRAFFIC SIGNAL CONTROLLER USING A WEB-BASED UI OR API.
- NON-INVASIVE VEHICLE DETECTION ZONES SHOWN IN THE PLANS ARE FOR ILLUSTRATIVE PURPOSES ONLY. FINAL DETECTION ZONES SHALL BE LOCATED IN THE FIELD AND APPROVED BY MAINEDOT AND THE RESIDENT ENGINEER.
- THE LOCATION OF THE DETECTION DEVICES SHOWN IN THE PLANS ARE CONCEPTUAL FOR OPTIMAL APPROACH COVERAGE. THE ACTUAL NUMBER OF DETECTION DEVICES AND MOUNTING LOCATIONS SHALL BE PER THE MANUFACTURER'S RECOMMENDATION.
- THE ENGINEER RESERVES THE RIGHT TO DIRECT THE CONTRACTOR TO ADJUST THE VIDEO DETECTOR MOUNTING HEIGHT FOR LOCAL CONDITIONS IDENTIFIED DURING OR AFTER INSTALLATION. NO ADDITIONAL COST WILL BE ALLOWED FOR FIELD ADJUSTING THE PIPE EXTENSIONS OR REWIRING AS NECESSARY. THIS WORK WILL BE INCIDENTAL TO THE 643.21 AND/OR 643.22 ITEM.

PREEMPTION

- INSTALL TOMAR COMPATABLE OPTICAL EMERGENCY VEHICLE PREEMPTION HARDWARE TO MATCH THE CITY OF WESTBROOK'S OTHER INSTALLATIONS. THIS WILL INCLUDE A PHASE SELECTOR IN EACH CABINET, 4 RED CONFIRMATION STROBES, AND 15 OPTICAL RECEIVERS
- PREEMPTION SIGNALS SHALL BE SERVICED ON A FIRST DETECTED, FIRST SERVED BASIS.
- IN RESPONSE TO A PREEMPTION SIGNAL RECEIVED AT THE INTERSECTION BY OPTICAL RECEIVERS, THE CONTROLLER SHALL HOLD OR ADVANCE TO AND HOLD IN EMERGENCY PREEMPTED PHASE(S) GREEN FOR A MINIMUM OF FIVE (15) SECONDS OR UNTIL THE PREEMPTION SIGNAL CEASES. THE CONTROLLER SHALL THEN TIME THE PREEMPTED PHASE(S) CLEARANCE, SERVICE SUBSEQUENT PREEMPTED PHASES AS NECESSARY, AND FINALLY RESUME NORMAL OPERATIONS.
- MINIMUM GREEN AND NORMAL VEHICLE CLEARANCE INTERVAL TIMES SHALL BE MAINTAINED ON PHASES THAT ARE TO BE TERMINATED BY PREEMPTION DEMAND.
- THE CONFIRMATION STROBE SHALL BE ILLUMINATED WHENEVER ANY EMERGENCY PREEMPTION SIGNAL IS RECIEVED BY THE CONTROLLER.
- FINAL PLACEMENT OF OPTICAL RECEIVERS SHALL BE COORDINATED WITH THE LOCAL FIRE DEPARTMENT.

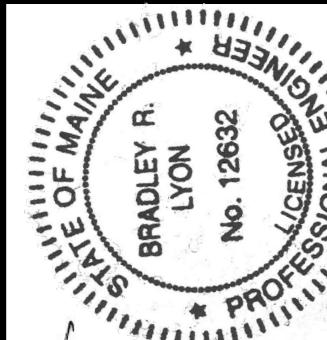
STATE OF MAINE DEPARTMENT OF TRANSPORTATION		02379700		WIN 023797.00		HIGHWAY PLANS	
		SIGNATURE BRADLEY R. LYON		P.E. NUMBER 12632		DATE 12/09/2021	
PROJ. MANAGER	DESIGN-DETAILED	CHECKED-REVIEWED	DATE	BY	DATE	BY	DATE
			08/30/19	C. THOMPSON	08/30/19		
			08/30/19	B. LYON	08/30/19		
				C. THOMPSON	07/17/20		
WESTBROOK CLARK DRIVE				TRAFFIC SIGNAL PLANS			
SHEET NUMBER				9			
				OF 46			

PEDESTRIAN SIGNALS AND PUSH BUTTONS

- HEADS SHALL BE ONE-WAY ONE-SECTION, 16' x 18" HAND/MAN WITH COUNTDOWN MODULE. HAND/MAN SYMBOL SHALL BE FILLED AND NOT OUTLINED.
- HEADS SHALL BE EQUIPPED WITH TUNNEL VISORS.
- HEADS SHALL BE CONSTRUCTED OF MOSS GREEN POLYCARBONATE MATERIAL WITH BLACK FACES.
- INSTALL 19 INCH ACCESSIBLE PEDESTRIAN SIGNAL (APS) PUSH BUTTONS - WITH R10-3e PUSH BUTTON SIGNS. SIGNS SHALL BE POSTED AT EACH APS PUSH BUTTON. THE AUDIBLE WALK INDICATION SHALL BE A PERCUSSIVE TONE AT ALL LOCATIONS AND SHALL MEET MUTCD REQUIREMENTS.
- PEDESTRIAN SIGNALS SHALL BE BLANK DURING FLASHING OPERATION
- LOCATOR TONES FOR ALL PUSH BUTTONS ARE REQUIRED. THEIR VOLUME IS TO BE AUTOMATICALLY ADJUSTED TO AMBIENT NOISE LEVELS.
- PEDESTRIAN PUSH BUTTONS SHALL HAVE A MAXIMUM ALLOWABLE REACH DISTANCE OF 24 INCHES. EXTENSION BRACKETS TO BE INSTALLED IF DEEMED NECESSARY.

TRAFFIC SIGNAL CONTROLLER / CABINET

- THE TRAFFIC SIGNAL CONTROLLER AND VARIOUS OTHER EQUIPMENT ITEMS SHOWN ON THE PLANS SHALL BE FURNISHED AND INSTALLED BY THE CONTRACTOR.
- THE TRAFFIC SIGNAL CONTROLLER SUPPLIED UNDER THIS CONTRACT SHALL BE A RACK MOUNTED TRAFFICWARE COMMANDER ADVANCED TRANSPORTATION CONTROLLER (ATC) WITH LATEST FIRMWARE INSTALLED AND CAPABLE OF SUPPORTING NTCIP PROTOCOLS AND COMMUNICATING WITH THE PACTS RTMS TMC SOFTWARE.
- THE CONTRACTOR SHALL BE SOLELY RESPONSIBLE FOR PROVIDING THE PROJECT WITH A FULLY CONFIGURED CONTROLLER AND CABINET.
- THE TRAFFIC SIGNAL CABINET SUPPLIED UNDER THIS CONTRACT SHALL BE AN ADVANCED TRANSPORTATION CONTROLLER CABINET (ATCC) THAT COMPLIES WITH THE MAINEDOT 32/48 ATC CABINET SPECIFICATIONS.

START UP AND ACCEPTANCE TESTING

- UPON COMPLETION OF THE WORK, THE CONTRACTOR SHALL INITIATE COMMUNICATIONS FROM THE PACTS RTMS CENTRAL SERVER THAT MANAGES THIS AREA IN THE PACTS REGION TO THE NEW INTERSECTIONS. THE CONTRACTOR SHALL TEST THE ABILITY TO REVIEW AND MODIFY THE ENTIRE TRAFFIC SIGNAL CONTROLLER DATABASE UTILIZING THE WEB-UI FRONT PANNEL DISPLAY. THE CONTRACTOR SHALL ALSO DEMONSTRATE THE ABILITY TO REMOTELY VIEW THE DETECTION CAMERAS, INCLUDING THE ABILITY TO REVISE DETECTION ZONES AND RETRIEVE COUNT INFORMATION. THE SYSTEM MUST BE FULLY FUNCTIONAL AND FREE OF COMMUNICATIONS OR EQUIPMENT FAILURES FOR A PERIOD OF SEVEN (7) DAYS. IF PROBLEMS OCCUR, THEY SHALL BE RECTIFIED BY THE CONTRACTOR AND THE START UP PERIOD RESTARTED FOR ANOTHER SEVEN (7) DAYS.
- UPON DEMONSTRATING A SUCCESSFUL 7 DAY START UP TEST, THE CITIES AND ITS ENGINEER SHALL EVALUATE THE OPERATION OF THE SYSTEM FOR A PERIOD OF 30 DAYS. DURING THIS PERIOD THE ENGINEER WILL DETERMINE IF THE VEHICLE COUNTING ABILITY OF THE CAMERAS IS AT LEAST 90% ACCURATE. SHOULD THE SYSTEM MALFUNCTION DURING THIS PERIOD OR THE ACCURACY OF THE CAMERAS IS DETERMINED TO BE INADEQUATE, THE CONTRACTOR SHALL MAKE ANY REPAIRS OR CORRECTIONS AND THE ACCEPTANCE TEST PERIOD WILL START OVER AGAIN. ACCEPTANCE TESTING MUST DEMONSTRATE TO THE CITIES AND ITS ENGINEER THAT THE COMMUNICATIONS CONNECTION AND ALL HARDWARE AND EQUIPMENT FUNCTION IN ACCORDANCE WITH THESE SPECIFICATIONS, REQUIREMENTS, THROUGH-PUTS AND FUNCTIONALITY.
- THE CONTRACTOR SHALL WARRANTY ALL WORK AND EQUIPMENT FOR A PERIOD OF ONE YEAR AFTER FINAL ACCEPTANCE.

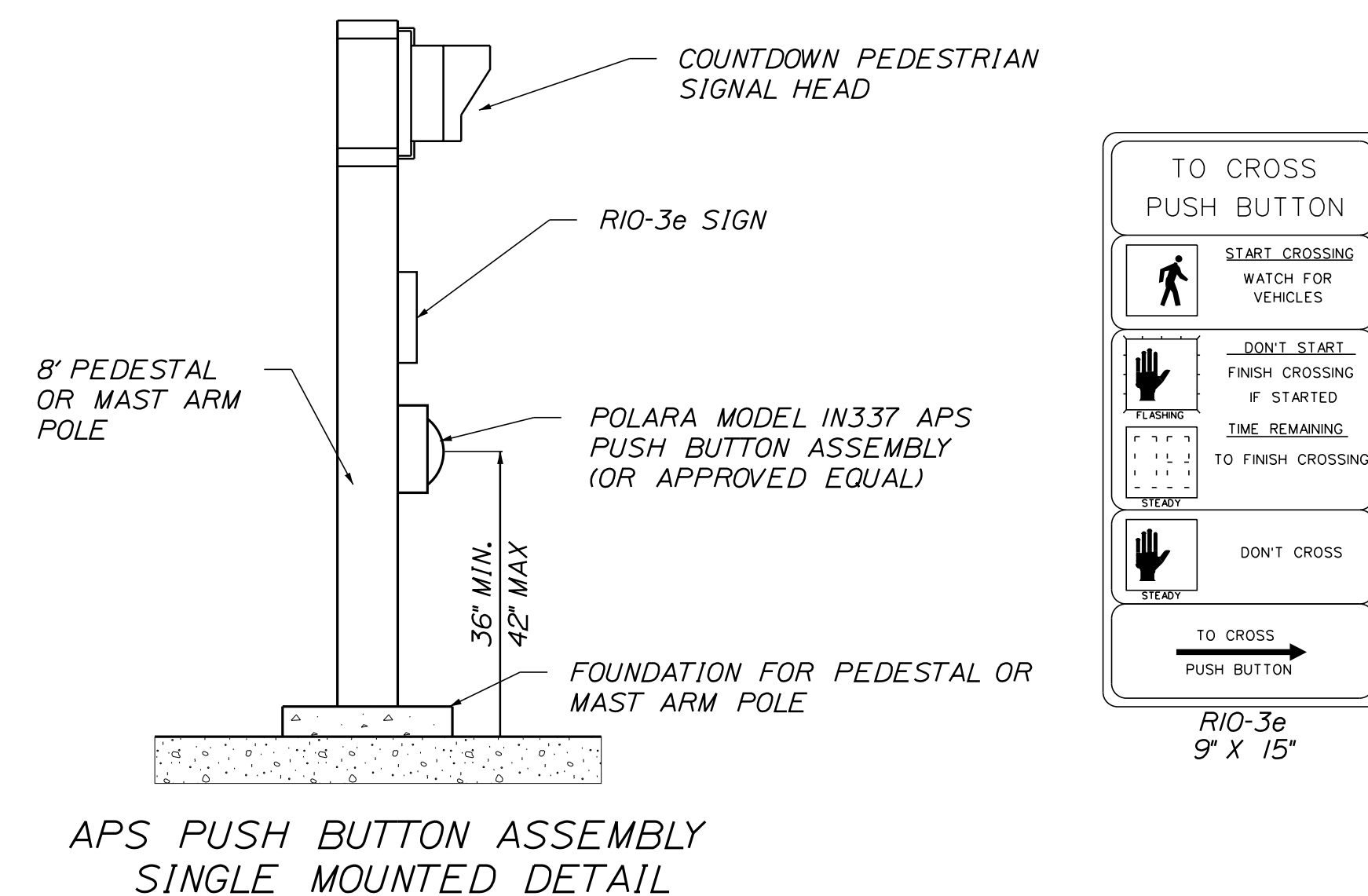

STATE OF MAINE DEPARTMENT OF TRANSPORTATION		02379700		WIN 023797.00		HIGHWAY PLANS					
				SIGNATURE		P.E. NUMBER					
				12632		1209/2021					
DATE		BY		E. MARTIN		DATE					
08/30/19		C. THOMPSON		E. MARTIN		07/15/20					
01/29/21		B. LYON		C. THOMPSON		07/29/21					
DESIGN-DETAILED		CHECKED-REVIEWED		REVISIONS 1		REVISIONS 2					
				REVISIONS 3							
WESTBROOK CLARK DRIVE				TRAFFIC SIGNAL PLANS				SHEET NUMBER			
								10		OF 46	

Date: 12/19/2021

Username: skelly

Division: HIGHWAY

Filename: ... \Sheets\009\_SignalNotes.dgn

PROPOSED SIGNAL INDICATIONS

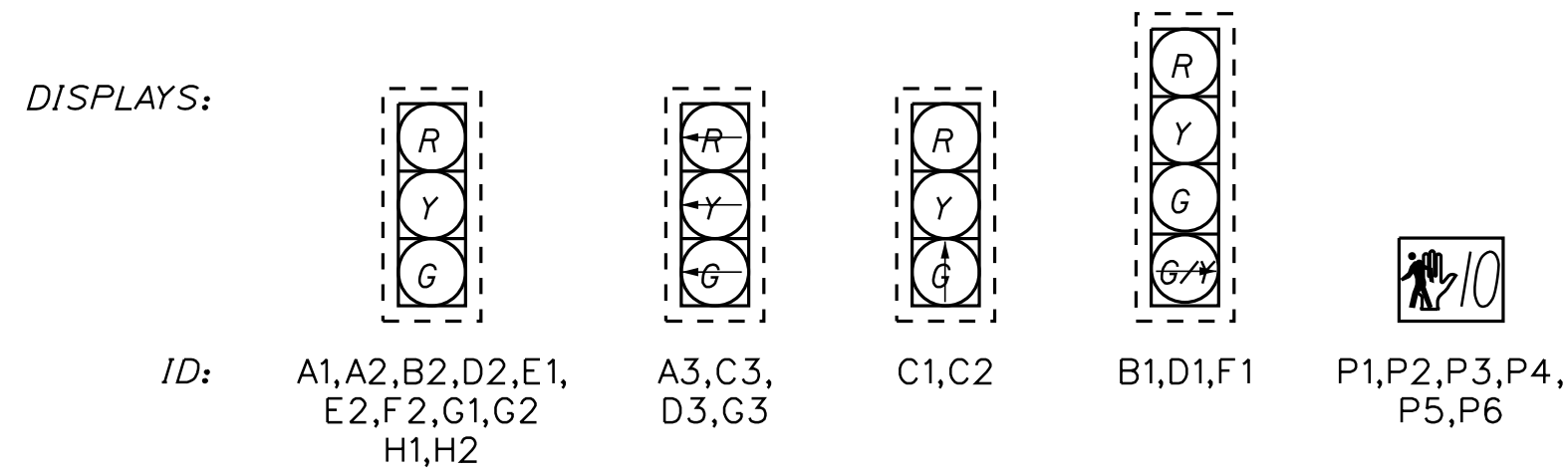

SIGNAL HEAD NOTES:

- ALL SIGNAL INDICATIONS SHALL BE 12 INCH WITH LIGHT EMITTING DIODES, 5" LOUVERED BACKPLATES, AND 3" RETRO-REFLECTIVE BORDERS
- ALL PEDESTRIAN INDICATIONS SHALL BE 16 INCH WITH LIGHT EMITTING DIODES AND COUNTDOWN DISPLAYS

PROPOSED ADVANCED DETECTION (DT5) WITH DETECTION ZONE STARTING 285' FROM THE EASTBOUND STOP BAR AND ENDING AT 235' FROM THE EASTBOUND STOP BAR

LIST OF MAJOR ITEMS

EQUIPMENT AND WORK ITEMS (ITEM 643.71)	QUANTITY	EQUIPMENT AND WORK ITEMS (ITEM 643.71)	QUANTITY	EQUIPMENT AND WORK ITEMS (ITEM 643.71)	QUANTITY
FURNISH AND INSTALL NEW ATCC MAINE DOT 3/4" SPEC TRAFFIC SIGNAL CABINET WITH ALL ANCILLARY EQUIPMENT AND WIRING INCLUDING FIELD MONITORING UNIT	1 LS	FURNISH AND INSTALL ONE-WAY, 16 X 18-INCH LED TOP OF POST MOUNTED BLACK COUNTDOWN PEDESTRIAN SIGNAL HEAD	3 EA	FURNISH AND INSTALL HARDENED ETHERNET ELECTRICAL TO SFP OPTICAL MEDIA CONVERTER (COMNET CWGE2SFT OR EQUAL)	2 EA
TRAFFICWARE COMMANDER ATC TRAFFIC SIGNAL CONTROLLER, W/ LATEST FIRMWARE INSTALLED	1 EA	FURNISH AND INSTALL ADA COMPLIANT ACCESSIBLE PEDESTRIAN SIGNAL (APS) BUTTON WITH 9"X15" RIO-3e INFORMATIONAL SIGN	6 EA	IMPLEMENT SYSTEM BASED AND LOCAL SIGNAL TIMINGS	1 LS
FURNISH AND INSTALL ONE-WAY, 3-SECTION, 12-INCH BLACK WITH BLACK DOOR TRAFFIC SIGNAL HEADS WITH BLACK TUNNEL VISORS AND RETROREFLECTIVE BACKPLATES MOUNTED ON MAST ARMS	17 EA	FURNISH AND INSTALL 4-CHANNEL PREEMPTION PHASE SELECTOR WITH SYSTEM CHASSIS	1 EA	THE LISTED QUANTITIES ARE APPROXIMATE AND ARE PROVIDED FOR INFORMATION ONLY.	
FURNISH AND INSTALL ONE-WAY, 4-SECTION, 12-INCH BLACK WITH BLACK DOOR TRAFFIC SIGNAL HEADS WITH BLACK TUNNEL VISORS AND RETROREFLECTIVE BACKPLATES MOUNTED ON MAST ARMS	3 EA	FURNISH AND INSTALL LIGHT-BASED PREEMPTION RECEIVERS WITH DETECTOR CABLE	7 EA	<b>GENERAL NOTES:</b>	
FURNISH AND INSTALL ONE-WAY, 16 X 18-INCH LED SIDE OF POLE MOUNTED BLACK COUNTDOWN PEDESTRIAN SIGNAL HEAD	3 EA	FURNISH AND INSTALL PREEMPTION CONFIRMATION RED STROBE WITH CABLE	2 EA	1. ALL CONDUIT SHALL BE 3" PVC SCH. 80	
		INSTALL 50-FOOT MAST ARM	3 EA	2. CONDUIT SHALL BE INSTALLED PER MAINE DOT'S STANDARD DETAIL 626(07).	
		INSTALL 35-FOOT MAST ARM	1 EA	3. CROSSWALKS ARE NOT DISPLAYED ON THIS PLAN FOR CLARITY.	
		INSTALL 25-FOOT MAST ARM	1 EA	4. ALL ETHERNET ENABLED EQUIPMENT SHALL BE CONNECTED TO THE FIELD MONITORING UNIT, INCLUDING THE ETHERNET ELECTRICAL TO SFP OPTICAL MEDIA CONVERTER.	

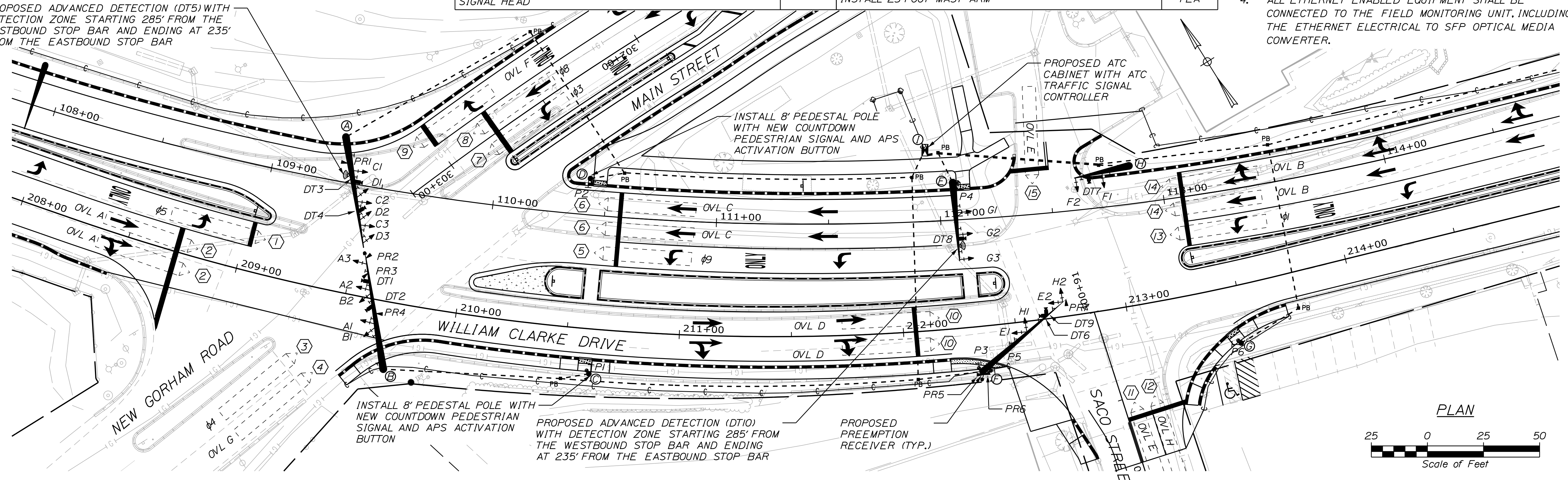

DETECTOR SCHEDULE

DETECTOR	TYPE	STREET	PLAN ID	LANE	PHASE	DETECTOR #	NOTES
DT1	VIDEO	WILLIAM CLARKE DRIVE	1	EBLT	φ5	5	
			2	EBTH	φ2	2	PRESENCE DETECTION ONLY, DOES NOT EXTEND PHASE
DT2	VIDEO	NEW GORHAM ROAD	3	NBTH-LT	φ4	4	
			4	NBRT	OVL G	4 OR 1	IF DETECTOR 4 IS ACTIVE THEN DETECTOR 4, ELSE DETECTOR 9
DT3	VIDEO	WILLIAM CLARKE DRIVE	5	WBLT	OVL D	1	
			6	WBTH	OVL B	6	PRESENCE DETECTION ONLY, DOES NOT EXTEND PHASE
			6	WBTH	OVL B	6	PRESENCE DETECTION ONLY, DOES NOT EXTEND PHASE
DT4	VIDEO	MAIN STREET	7	SBLT	φ3	3	
			8	SBTH	OVL G	4	
			9	SBRT	OVL F	5 OR 8	IF DETECTOR 8 IS ACTIVE THEN DETECTOR 8, ELSE DETECTOR 5
DT5	ADVANCED	WILLIAM CLARKE DRIVE	-	EBTH	-	2	
DT6	VIDEO	WILLIAM CLARKE DRIVE	10	EBTH	OVL D	2	PRESENCE DETECTION ONLY, DOES NOT EXTEND PHASE
			10	EBTH-RT	OVL D	2	PRESENCE DETECTION ONLY, DOES NOT EXTEND PHASE
DT7	VIDEO	SACCO STREET	11	NBTH-LT	OVL E	9	
			12	NBRT	OVL H	1 OR 9	IF DETECTOR 9 IS ACTIVE THEN DETECTOR 9, ELSE DETECTOR 1
DT8	VIDEO	WILLIAM CLARKE DRIVE	13	WBLT	1	1	
			14	WBTH	OVL B	6	PRESENCE DETECTION ONLY, DOES NOT EXTEND PHASE
DT9	VIDEO	COMMERCIAL ENTRANCE	14	WBTH-RT	OVL B	6	PRESENCE DETECTION ONLY, DOES NOT EXTEND PHASE
			15	SB	φ4	9	
DT10	ADVANCED	WILLIAM CLARKE DRIVE	-	WBTH	-	6	

PREEMPTION SCHEDULE

I.D.	RECEIVER PRIORITY	PRIORITY PHASE
PR1	3	φ2-φ5
PR2	5	φ3-φ8
PR3	6	φ4
PR4	4	φ1-φ6-φ9
PR5	3	φ2-φ5
PR6	4	φ1-φ6
PR7	7	φ9

SIGNAL LAYOUT

STRUCTURE	LOCATION (STA.)	DESCRIPTION	FOUNDATION
A	109+30.06, 19.9' LT	50' MAST ARM	D60"xL17'
B	209+72.50, 29.9' RT	50' MAST ARM	D54"xL17'
C	210+61.32, 20.0' RT	8' PEDESTAL POLE	D24"xL7'
D	110+42.38, 16.2' LT	8' PEDESTAL POLE	D24"xL7'
E	112+06.34, 16.7' LT	35' MAST ARM	D42"xL16'
F	212+33.50, 20.0' RT	50' MAST ARM	D54"xL18'
G	213+46.62, 25.53' RT	8' PEDESTAL POLE	D24"xL7'
H	112+86.40, 16.9' LT	25' MAST ARM	D42"xL11'
I	111+94.45, 31.8' LT	CONTROLLER CABINET	L48"xW36"xH48"

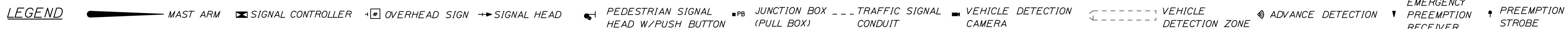

Date: 12/19/2021  
Username: skelly  
Division: HIGHWAY  
Filename: ... \Sheets\011\_Signal Plan.dgn

STATE OF MAINE DEPARTMENT OF TRANSPORTATION 02379700 WIN 023797.00 HIGHWAY PLANS

STATE OF MAINE BRADLEY R. LYON No. 12632 PROFESSIONAL ENGINEER

WESTBROOK WILLIAM CLARKE DRIVE TRAFFIC SIGNAL PLANS

SHEET NUMBER 11 OF 46

PROJ. MANAGER	E. MARTIN	DATE	
DESIGN-DETAILED	C. THOMPSON	08/30/19	
CHECKED-REVIEWED	B. LYON	07/29/21	
REVISIONS 1	C. THOMPSON	07/15/20	
REVISIONS 2	C. THOMPSON	07/29/21	
REVISIONS 3			

SIGNATURE: 12632 P.E. NUMBER: 1209/2021 DATE: 12/09/2021

Filename: ... \MSTA\Sheets\012\_Sign Plan.dgn Division: HIGHWAY Username: skelly Date: 12/19/2021

LIST OF MAJOR ITEMS

EQUIPMENT AND WORK ITEMS	QUANTITY
FURNISH AND INSTALL 14-INCH PRECAST JUNCTION BOX (ITEM 626.11)	9 EA
FURNISH AND INSTALL NON-METALLIC CONDUIT, CONCRETE ENCASED (ITEM 626.221)	50 LF
FURNISH AND INSTALL (3-INCH) NON-METALLIC CONDUIT (ITEM 626.22)	1,275 LF
FURNISH AND INSTALL 24-INCH FOUNDATION (ITEM 626.421)	21 LF
FURNISH AND INSTALL 42-INCH DIAMETER FOUNDATION (ITEM 626.451)	27 LF
FURNISH AND INSTALL 54-INCH DIAMETER FOUNDATION (ITEM 626.47)	35 LF
FURNISH AND INSTALL 60-INCH DIAMETER FOUNDATION (ITEM 626.48)	17 LF
FURNISH AND INSTALL CONTROLLER CABINET FOUNDATION (ITEM 626.35)	1 EA

LIST OF MAJOR ITEMS (CONT.)

EQUIPMENT AND WORK ITEMS	QUANTITY
FURNISH AND INSTALL NON-INVASIVE STOP BAR VEHICLE DETECTION SYSTEM FOR 8 APPROACHES, COMPLETE (ITEM 643.21)	1 LS
FURNISH AND INSTALL NON-INVASIVE ADVANCE VEHICLE DETECTION SYSTEM FOR 2 APPROACHES, COMPLETE (ITEM 643.22)	1 LS
FURNISH AND INSTALL FIBER INTERCONNECT BETWEEN MECHANIC STREET AND SACO STREET (ITEM 643.90)	745 LF
FURNISH AND INSTALL 50' MAST ARM POLE (ITEM 643.91)	3 EA
FURNISH AND INSTALL 35' MAST ARM POLE (ITEM 643.91)	1 EA
FURNISH AND INSTALL 25' MAST ARM POLE (ITEM 643.91)	1 EA
FURNISH AND INSTALL 8-FOOT PEDESTAL POLE (ITEM 643.92)	3 EA

THE LISTED QUANTITIES ARE APPROXIMATE AND ARE PROVIDED FOR INFORMATION ONLY.

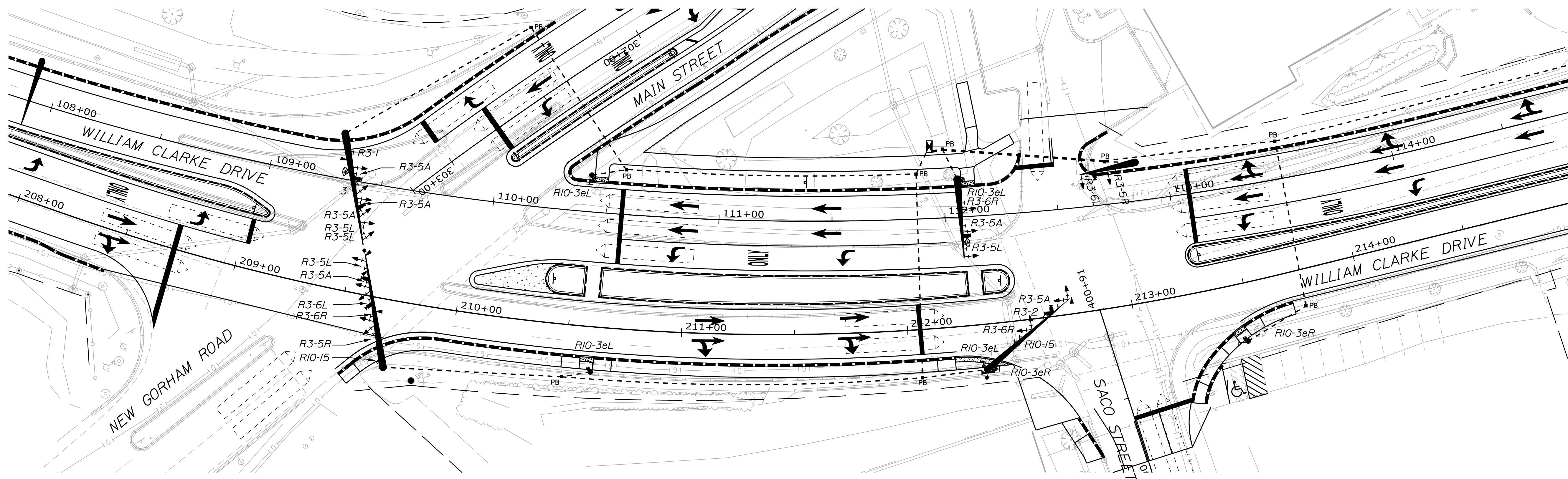

PROPOSED SIGNS

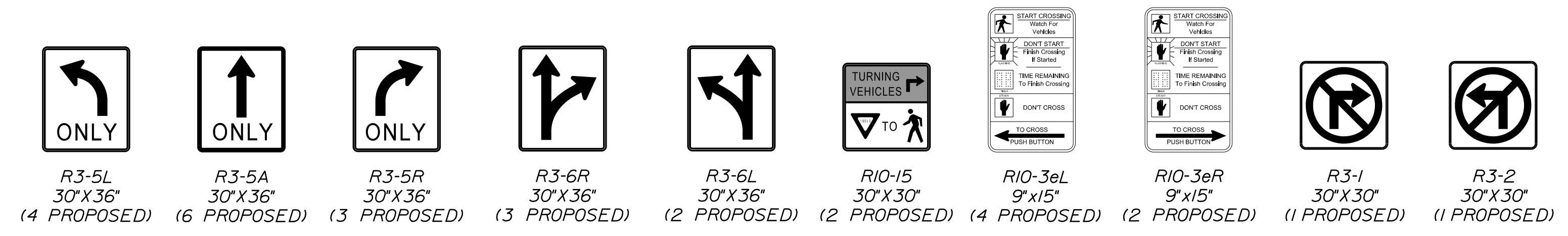

NOTE:  
1. ALL OVERHEAD SIGNS SHALL BE INCIDENTAL TO ITEM 643.71 TRAFFIC SIGNAL MODIFICATION

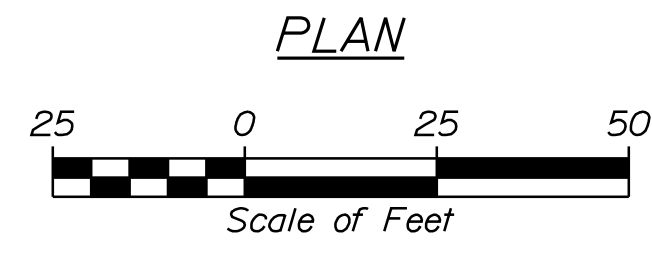

LEGEND — MAST ARM — SIGNAL CONTROLLER — OVERHEAD SIGN — SIGNAL HEAD — PEDESTRIAN SIGNAL HEAD W/PUSH BUTTON — JUNCTION BOX (PULL BOX) — TRAFFIC SIGNAL CONDUIT — VEHICLE DETECTION CAMERA — VEHICLE DETECTION ZONE — ADVANCE DETECTION — EMERGENCY PREEMPTION RECEIVER — PREEMPTION STROBE

STATE OF MAINE  
DEPARTMENT OF TRANSPORTATION  
02379700  
WIN  
023797.00  
HIGHWAY PLANS

STATE OF MAINE  
BRADLEY R. LYON  
No. 12632  
LICENSED PROFESSIONAL ENGINEER

PROJ. MANAGER: E. MARTIN  
DESIGN-DETAILED: C. THOMPSON (08/30/19)  
CHECKED-REVIEWED: B. LYON (07/29/21)  
REVISIONS: 1 C. THOMPSON (07/15/20), 2 C. THOMPSON (07/29/21), 3 C. THOMPSON (07/29/21)

SIGNATURE: [Signature]  
12632  
P.E. NUMBER: 1209/2021  
DATE: 12/09/2021

WESTBROOK  
WILLIAM CLARKE DRIVE  
TRAFFIC SIGNAL PLANS

SHEET NUMBER  
12  
OF 46

Date: 12/19/2021

Username: skelly

Division: HIGHWAY

Filename: ... Sheets\013\_Timing Plan.dgn

PREFERENTIAL PHASE SEQUENCE

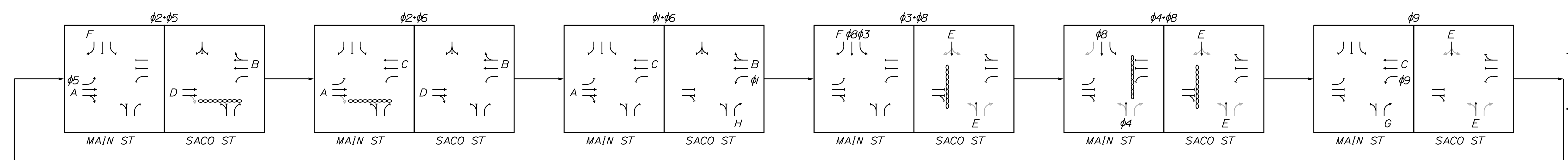

NEMA RING AND BARRIER DIAGRAM

2 12 1 || 3 4 || 9  
5 6 16 || 8 ||

OVERLAP PHASING:

- OVL A = φ1 · φ2
- OVL B = φ5 · φ6
- OVL C = φ6 · φ9 · φ16
- OVL D = φ2 · φ12
- OVL E = φ3 · φ4 · φ9
- OVL F = φ3 · φ5
- OVL G = φ9
- OVL H = φ1

PHASING NOTES:

1. PEDESTRIAN PHASES UPON PUSH BUTTON ACTIVATION ONLY
2. OVERLAP E IS DISABLED WHEN THE PHASE 4 AND/OR PHASE 8 PEDESTRIAN PHASES ARE ACTIVE.
3. PERMITTED MOVEMENTS NOT SUPPORTED BY SIGNAL INDICATIONS ARE SHOWN IN GRAY.
4. PHASE 12 AND PHASE 16 ARE INTENDED TO ESTABLISH A TRAILING GREEN INDICATION FOR THE DOWNSTREAM APPROACHES AND SHALL BE CONFIGURED TO ALWAYS FOLLOW PHASE 2 AND PHASE 6 RESPECTIVELY. OTHER METHODOLOGIES FOR ESTABLISHING A TRAILING GREEN INDICATION MAY BE USED AS APPROVED BY THE ENGINEER.

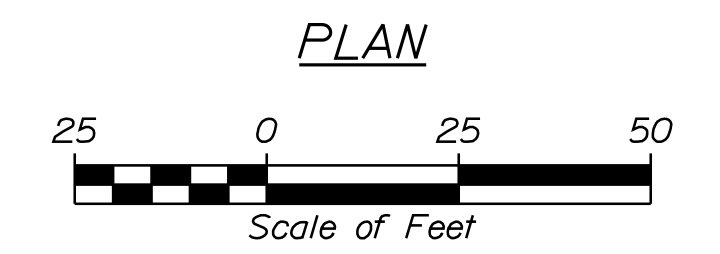

SIGNAL TIMING SCHEDULE

ITEM / PHASE	φ 1	φ 2	φ 3	φ 4	φ 5	φ 6	φ 7	φ 8	φ 9	φ 12	φ 16
MINIMUM INITIAL	5.0	5.0	5.0	5.0	5.0	5.0	-	5.0	5.0	3.0	3.0
PASSAGE TIME	1.5	1.5	1.5	1.5	1.5	1.5	-	1.5	1.5	-	-
MAXIMUM 1	10	25	15	15	10	25	-	35	25	3.0	3.0
MAXIMUM 2	20	35	25	25	20	35	-	55	25	3.0	3.0
YELLOW	3.5	3.5	3.5	3.5	3.5	3.5	-	3.5	3.5	3.5	3.5
ALL RED	1.5	1.5	1.5	1.5	1.5	1.5	-	1.5	1.5	1.5	1.5
PED WALK	-	7.0	-	7.0	-	-	-	7.0	-	-	-
PED CLEAR	-	32.0	-	20.0	-	-	-	20.0	-	-	-
RECALL	-	S	-	-	-	S	-	-	-	-	-
DETECTOR	PR	PR	PR	PR	PR	PR	-	PR	PR	-	-
PREEMPT PRIORITY	-	3	5	6	3	4	-	5	6	-	-
FLASH	R	R	R	R	R	R	-	R	R	-	-
DUAL ENTRY	-	X	-	X	-	X	-	X	-	-	-

SIGNAL TIMING NOTES:

1. DEFINITIONS
  - S = SOFT RECALL
  - O = RECALL OFF
  - PR = PRESENCE
  - Y = YELLOW
  - R = RED
  - D = DARK

COORDINATION CYCLE/SPLIT/OFFSET SCHEDULE

ALL ENTRIES IN SECONDS

PLAN NUMBER	PLAN 11	PLAN 12	PLAN 13
CYCLE LENGTH	100	95	110
OFFSET	96	5	93
COORDINATED φ	2	2	2
SPLIT TIME φ 1	13	19	16
SPLIT TIME φ 2	40	24	30
SPLIT TIME φ 3	12	14	16
SPLIT TIME φ 4	13	14	18
SPLIT TIME φ 5	18	15	16
SPLIT TIME φ 6	35	24	30
SPLIT TIME φ 7	-	-	-
SPLIT TIME φ 8	25	28	34
SPLIT TIME φ 9	14	16	22
SPLIT TIME φ 12	8	8	8
SPLIT TIME φ 16	8	8	8

COORDINATION NOTES:

1. OFFSET IS REFERENCED TO THE END OF THE COORDINATED PHASE GREEN
2. COORDINATION TO OPERATE BY TIME-OF-DAY (SEE DAILY AND WEEKLY COORDINATION SCHEDULE).
3. COORDINATION TO OPERATE UNDER FIXED FORCE OFF MODE.
4. THE CONTROLLER SHALL BE CONFIGURED TO ONLY TRANSITION BY INCREASING THE CYCLE LENGTH BY AT LEAST 40 PERCENT.

DAY PLAN 11

EVENT NUMBER	TIME	ACTION
1	00:00	54
2	07:00	11
3	10:00	12
4	15:45	13
5	18:00	12
6	20:00	54

DAY PLAN 2

EVENT NUMBER	TIME	ACTION
1	00:00	54
2		
3		
4		
5		
6		

COORDINATION SCHEDULE

DAY PLAN	DAY OF WEEK						
	SUN	MON	TUE	WED	THU	FRI	SAT
11	-	X	X	X	X	X	-
2	X	-	-	-	-	-	X

STATE OF MAINE  
DEPARTMENT OF TRANSPORTATION

02379700

WIN 023797.00 HIGHWAY PLANS

SIGNATURE: *Bradley R. Lyon*  
12632  
P.E. NUMBER: 12632  
DATE: 12/09/2021

E. MARTIN  
BY: C. THOMPSON 08/30/19  
B. LYON 01/29/21  
DATE: 12/09/2021

PROJ. MANAGER: E. MARTIN  
DESIGN-DETAILED: C. THOMPSON 07/15/20  
CHECKED-REVIEWED: C. THOMPSON 07/29/21  
REVISIONS 1: C. THOMPSON 07/15/20  
REVISIONS 2: C. THOMPSON 07/29/21  
REVISIONS 3: C. THOMPSON 07/29/21

WESTBROOK CLARKE DRIVE  
TRAFFIC SIGNAL PLANS

SHEET NUMBER  
**13**  
OF 46

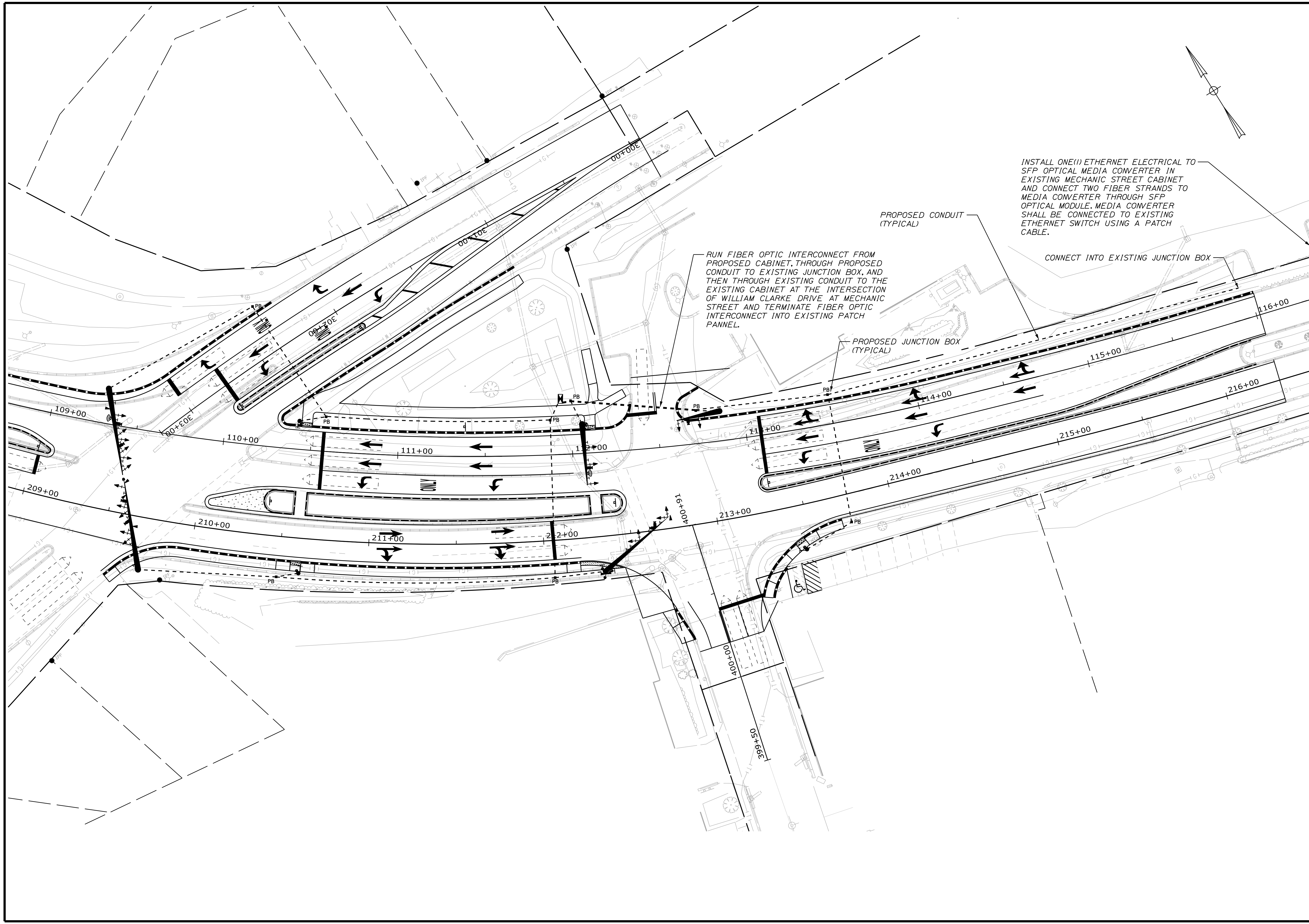

STATE OF MAINE  
DEPARTMENT OF TRANSPORTATION  
02379700  
WIN  
023797.00  
HIGHWAY PLANS

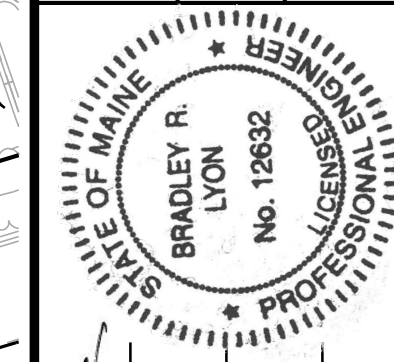

PROJ. MANAGER	E. MARTIN	BY	DATE
DESIGN DETAILED	C. THOMPSON	08/30/19	
CHECKED-REVIEWED	B. LYON	08/30/19	
REVISIONS 1	C. THOMPSON	07/15/20	P.E. NUMBER 12632
REVISIONS 2	C. THOMPSON	07/29/21	P.E. NUMBER 12632
REVISIONS 3			DATE 12/09/2021

WESTBROOK CLARKE DRIVE  
TRAFFIC SIGNAL PLANS

SHEET NUMBER  
**14**  
OF 46

Filename: ... \015\_HDPlan1.dgn  
 Division: HIGHWAY  
 Username: morin  
 Date: 12/18/2021

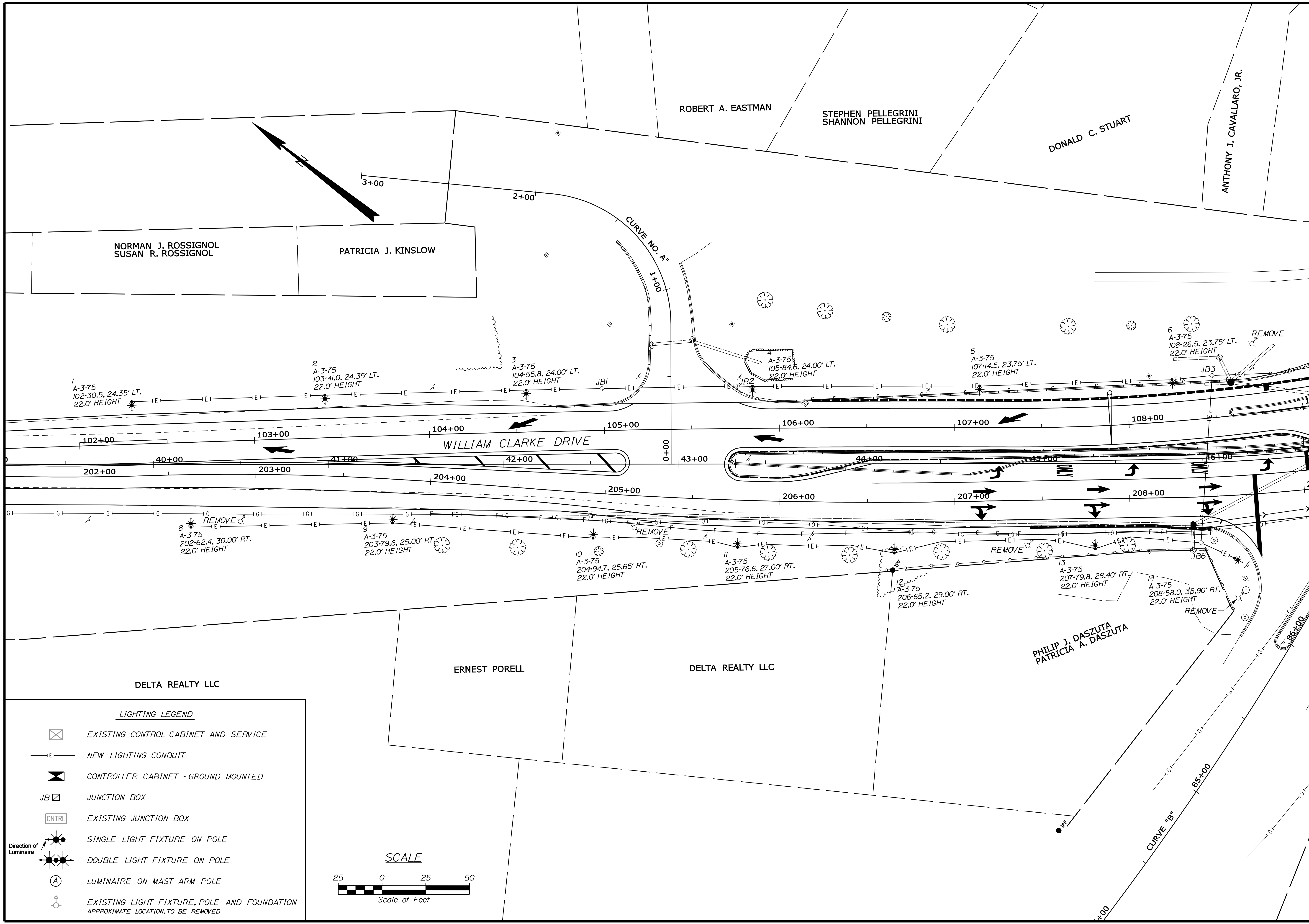

**LIGHTING LEGEND**

- EXISTING CONTROL CABINET AND SERVICE
- NEW LIGHTING CONDUIT
- CONTROLLER CABINET - GROUND MOUNTED
- JUNCTION BOX
- EXISTING JUNCTION BOX
- SINGLE LIGHT FIXTURE ON POLE
- DOUBLE LIGHT FIXTURE ON POLE
- LUMINAIRE ON MAST ARM POLE
- EXISTING LIGHT FIXTURE, POLE AND FOUNDATION APPROXIMATE LOCATION, TO BE REMOVED

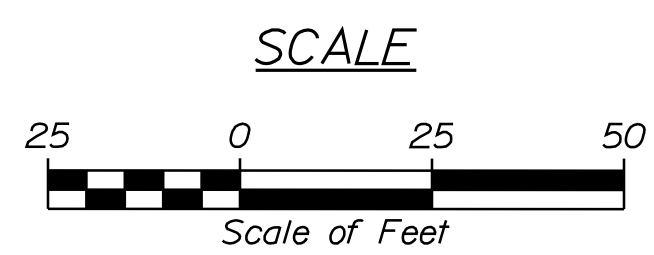

STATE OF MAINE DEPARTMENT OF TRANSPORTATION		PROJECT NUMBER <b>02379700</b>	
PROJECT TITLE <b>WESTBROOK WILLIAM CLARK DRIVE</b>		DATE 12/21	
DRAWN BY [Signature]		CHECKED BY [Signature]	
DESIGNED BY [Signature]		APPROVED BY [Signature]	
DATE 12/21		DATE 12/21	
SIGNATURE [Signature]		P.E. NUMBER 4226	
DATE 12/21		DATE 12/21	
DESIGN DETAIL NO.		DESIGN DETAIL NO.	
DESIGN DETAIL NO.		DESIGN DETAIL NO.	
REVISIONS 1		REVISIONS 2	
REVISIONS 3		REVISIONS 4	
FIELD CHANGES		FIELD CHANGES	
SHEET NUMBER <b>15</b>		HIGHWAY PLANS WIN 023797.00	
OF 46			

Filename: ... \016\_HDPlan2.dgn  
 Division: HIGHWAY  
 Username: morin  
 Date: 12/18/2021

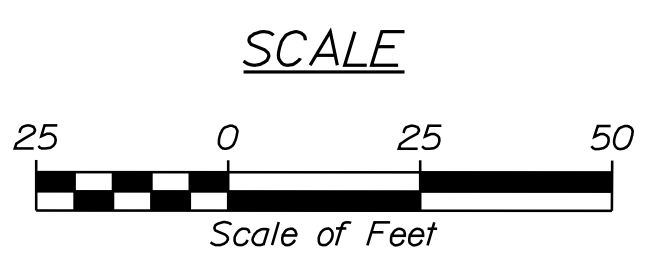
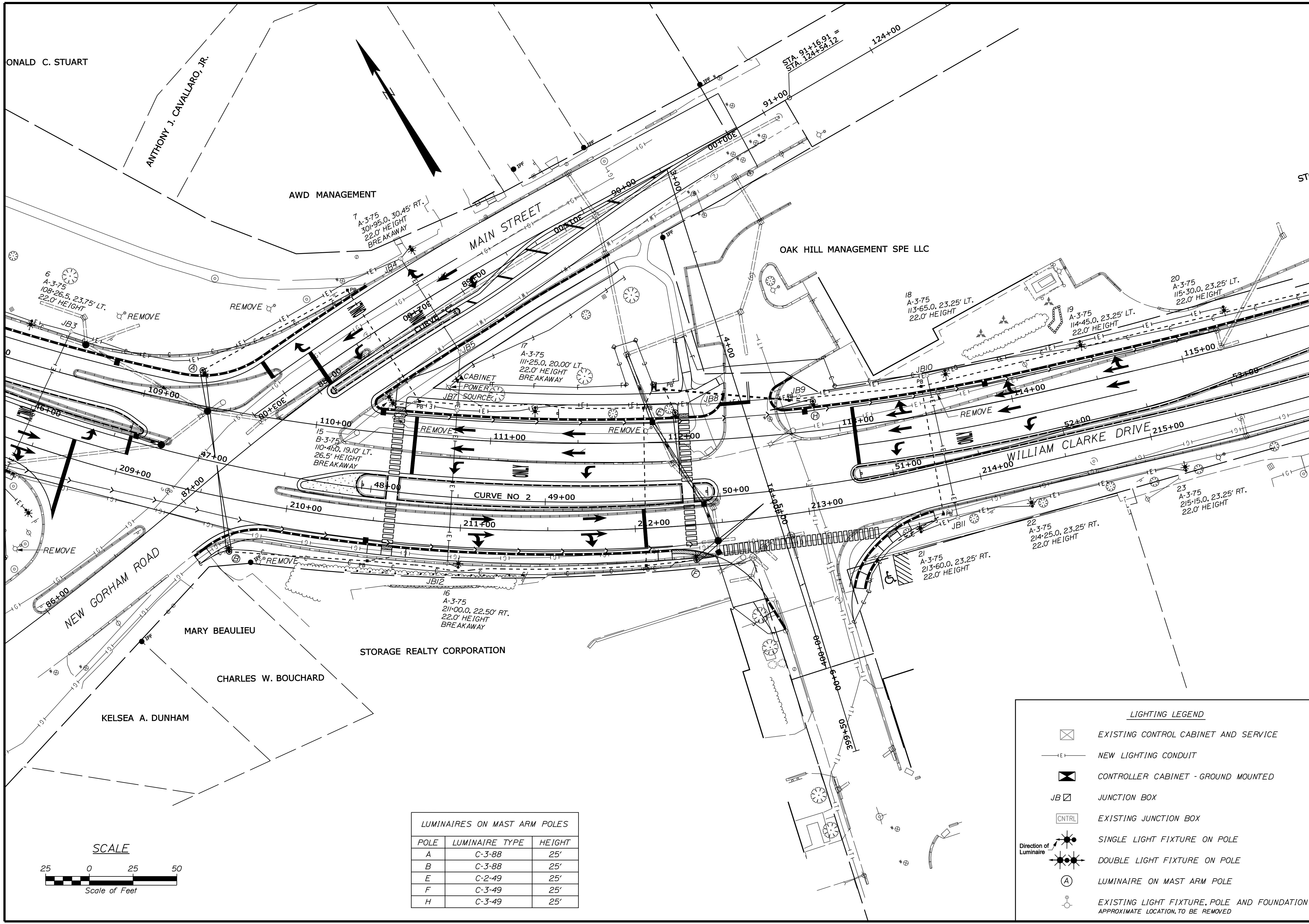

LUMINAIRES ON MAST ARM POLES		
POLE	LUMINAIRE TYPE	HEIGHT
A	C-3-88	25'
B	C-3-88	25'
E	C-2-49	25'
F	C-3-49	25'
H	C-3-49	25'

**LIGHTING LEGEND**

- EXISTING CONTROL CABINET AND SERVICE
- NEW LIGHTING CONDUIT
- CONTROLLER CABINET - GROUND MOUNTED
- JUNCTION BOX
- EXISTING JUNCTION BOX
- SINGLE LIGHT FIXTURE ON POLE
- DOUBLE LIGHT FIXTURE ON POLE
- LUMINAIRE ON MAST ARM POLE
- EXISTING LIGHT FIXTURE, POLE AND FOUNDATION APPROXIMATE LOCATION, TO BE REMOVED

Direction of Luminaire

STATE OF MAINE  
 DEPARTMENT OF TRANSPORTATION  
**02379700**  
 WIN  
 023797.00  
 HIGHWAY PLANS

PROJ. MANAGER: [Signature]  
 CHECKED/REVIEWED: \$484/01/15  
 DESIGNED/DETAILS: [Signature]  
 REVISIONS: 1, 2, 3, 4  
 FIELD CHANGES

DATE: 12/18/21  
 SIGNATURE: [Signature]  
 P.E. NUMBER: 4226  
 DATE: 12/18/21

WESTBROOK CLARK DRIVE  
 LIGHTING PLANS

SHEET NUMBER  
**16**  
 OF 46

STATISTICS					
DESCRIPTION	AVG	MAX	MIN	MAX/MIN	AVG/MIN
1_102-00 TO 105-00	1.1 FC	1.9 FC	0.5 FC	3.8:l	2.2:l
2_105-00 TO 109-00	0.9 FC	1.9 FC	0.4 FC	4.8:l	2.3:l
3_MAIN STREET INTERSECTION	1.4 FC	2.7 FC	0.5 FC	5.4:l	2.8:l
4_110-25 TO 112-00	1.1 FC	2.2 FC	0.4 FC	5.5:l	2.8:l
5_SACO STREET INTERSECTION	1.1 FC	2.3 FC	0.4 FC	5.8:l	2.8:l
6_113-00 TO 115-80	1.4 FC	3.1 FC	0.9 FC	3.4:l	1.6:l
7_MAIN STREET APPROACH	1.2 FC	2.1 FC	0.4 FC	5.3:l	3.0:l
8_NEW GORHAM RD APPROACH	1.5 FC	2.5 FC	0.6 FC	4.2:l	2.5:l

SCHEDULE											
SYMBOL	LABEL	QTY	MANUFACTURER	CATALOG NUMBER	DESCRIPTION	NUMBER LAMPS	FILENAME	LUMENS PER LAMP	LLF	WATTAGE	
	C-2-49	1	AMERICAN ELECTRIC LIGHTING	ATBO P202 R2 4K	Autobahn Small P202 Package Roadway Type II 4000K	1	ATBO_P202_R2_4K.ies	7203	0.85	49	
	C-3-49	2	AMERICAN ELECTRIC LIGHTING	ATBO P202 R3 4K	Autobahn Small P202 Package Roadway Type III 4000K	1	ATBO_P202_R3_4K.ies	7237	0.85	49	
	A-3-75	22	ZUMA LIGHTING	PRM 70W U 4K T3 A 28 BK S	Zuma Premier LED Architectural Single 28 Inch Dia. Type III 4000K	1	DL-S-70W-3M-4000K.ies	7542	0.85	75.45	
	B-3-75	1	ZUMA LIGHTING	PRM 70W U 4K T3 B 28 BK S	Zuma Premier LED Architectural Double 28 Inch Dia. Type III 4000K	2	DL-S-70W-3M-4000K.ies	7542	0.85	150.9	
	C-3-88	2	AMERICAN ELECTRIC LIGHTING	ATBO P204 R3 4K	Autobahn Small P204 Package Roadway Type III 4000K	1	ATBO_P204_R3_4K.ies	12469	0.85	88	

CIRCUIT 1				WIRE SIZE	
				240 VOLTS, #8 AWG STRANDED COPPER XHHW-2	
STATION	POLE	BREAKAWAY	DISTANCE (FT.)	REMARKS	
POWER SOURCE UTILITY POLE	---	---		14 FIXTURES	8.80 AMPS
CONTROL CABINET 110-80, 34' LT.	---	---	25	METALLIC CONDUIT. LENGTH INCLUDES RISER.	
JB5, 302-02, 36' LT.	---	---	16		
JB4, 302-03, 28' RT.	---	---	64	NON-METALLIC UNDER PAVEMENT CONDUIT	
JB3, 108-50, 24' LT.	---	---	205		
108-26.5, 23.75' LT.	6	NO	24		
107-14.5, 23.75' LT.	5	NO	110		
105-84.6, 24.00' LT.	4	NO	130		
JB2, 105-77, 24' LT.	---	---	8		
JB1, 104-99, 24' LT.	---	---	78	NON-METALLIC UNDER PAVEMENT CONDUIT	
104-55.8, 24.00' LT.	3	NO	44		
103-41.0, 24.35' LT.	2	NO	115		
102-30.5, 24.35' LT.	1	NO	111		
301-95.0, 30.45' RT.	7	YES	9		
JB4, 302-03, 28' RT.	---	---			
202-62.4, 30.00' RT.	8	NO	115		
203-79.6, 25.00' RT.	9	NO	115		
204-94.7, 25.65' RT.	10	NO	83		
205-76.6, 27.00' RT.	11	NO	90		
206-65.2, 29.00' RT.	12	NO	116		
207-79.8, 28.40' RT.	13	NO	62		
JB6, 208-40, 26' RT.	---	---	96	NON-METALLIC UNDER PAVEMENT CONDUIT	
JB3, 108-50, 24' LT.	---	---			
208-58.0, 35.90' RT.	14	NO	21		
JB6, 208-40, 26' RT.	---	---			

CIRCUIT 2				WIRE SIZE	
				240 VOLTS, #8 AWG STRANDED COPPER XHHW-2	
STATION	POLE	BREAKAWAY	DISTANCE (FT.)	REMARKS	
CONTROL CABINET 110-80, 34' LT.	---	---	18	10 FIXTURES	6.92 AMPS
JB7, 110-80, 16.5' LT.	---	---	46		
111-25.0, 20.00' LT.	17	YES	99		
JB8, 112-25, 20.5' LT.	---	---	52	NON-METALLIC UNDER PAVEMENT CONDUIT	
JB9, 112-78, 20.5' LT.	---	---	75		
JB10, 113-54, 22.5' LT.	---	---	11		
113-65.0, 23.25' LT.	18	NO	79		
114-45.0, 23.25' LT.	19	NO	85		
115-30.0, 23.25' LT.	20	NO			
110-41.0, 19.10' LT.	15	YES	39	DOUBLE FIXTURE ON POLE 15	
JB7, 110-80, 16.5' LT.	---	---			
211-00.0, 22.50' RT.	16	YES	7		
JB12, 210-94, 20.7' RT.	---	---	88	NON-METALLIC UNDER PAVEMENT CONDUIT	
JB7, 110-80, 16.5' LT.	---	---			
213-60.0, 23.25' RT.	21	NO	23		
JB11, 213-82, 20.0' RT.	---	---			
215-15.0, 23.25' RT.	23	NO	93		
214-25.0, 23.25' RT.	22	NO	44		
JB11, 213-82, 20.0' RT.	---	---	83	NON-METALLIC UNDER PAVEMENT CONDUIT	
JB10, 113-54, 22.5' LT.	---	---			

NOTE:  
ALL CONDUIT IS INTENDED TO BE NON-METALLIC UNLESS NOTED.

STATE OF MAINE  
DEPARTMENT OF TRANSPORTATION

02379700

WIN  
023797.00  
HIGHWAY PLANS

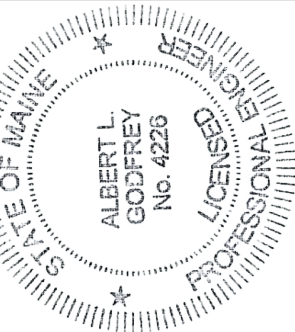

*Albert J. Jeffrey*  
SIGNATURE  
4226  
P.E. NUMBER  
12/8/21  
DATE

PROJ. MGR	MANAGER	DATE
BRIAN KEIZER	MSM	9-21
DESIGN-DETAILED	ALG	9-21
CHECKED-REVIEWED	ALG	
DESIGN-DETAILED	ALG	
DESIGN-DETAILED	ALG	
REVISIONS 1		
REVISIONS 2		
REVISIONS 3		
REVISIONS 4		
FIELD CHANGES		

WESTBROOK  
WILLIAM CLARK DRIVE  
LIGHTING DETAILS  
AND CONDUIT TABLES

SHEET NUMBER

17

OF 46

**CONSTRUCTION NOTES - HIGHWAY LIGHTING**

1. SCOPE OF WORK - INSTALL HIGHWAY LIGHTING AS SHOWN ON THESE PLANS. INSTALL NEW 240V POWER SERVICE, MULTI-CIRCUIT LIGHTING CONTROL CABINET AND SERVICE DISCONNECT ENCLOSURE. FURNISH AND INSTALL CONDUIT, FOUNDATIONS, CONVENTIONAL LIGHT STANDARDS, L.E.D. LUMINAIRES, WIRING, AND RELATED HARDWARE. REMOVE EXISTING LIGHTING AND FOUNDATIONS WHERE NOTED ON PLANS.

2. EXISTING LIGHTING POLES NOTED AS 'REMOVE' ON THE LIGHTING PLANS ARE INTENDED TO HAVE EXISTING FOUNDATIONS ALSO REMOVED AS DIRECTED. PAYMENT FOR REMOVAL OF FOUNDATIONS WILL BE MADE UNDER ITEM 626.36. ABANDON EXISTING CONDUIT.

3. ALL MATERIALS AND WORKMANSHIP SHALL CONFORM TO APPLICABLE PROVISIONS OF THE CURRENT EDITIONS OF THE MAINE DEPARTMENT OF TRANSPORTATION STANDARD SPECIFICATIONS AND STANDARD DETAILS, NATIONAL ELECTRICAL CODE (N.E.C.) AND ANY REQUIREMENTS OF THE POWER COMPANY.

4. THE CONTRACTOR SHALL VISIT THE SITE PRIOR TO BIDDING TO ENSURE AWARENESS OF SITE CONDITIONS THAT COULD AFFECT THE BID.

5. THE CONTRACTOR SHALL FIELD VERIFY POLE LOCATIONS TO AVOID NATURAL AND BUILT SITE FEATURES THAT WOULD CONFLICT WITH PROPER INSTALLATION OF POLE FOUNDATIONS.

6. THE SERVICE CABINET, DISCONNECT ENCLOSURE AND OTHER ENCLOSURES FOR ELECTRICAL COMPONENTS SHALL BE MARKED WITH ARC HAZARD TYPE 1, 2, 3 OR 4 AND THE APPROPRIATE PPE REQUIRED.

7. ALL LIGHTING CIRCUITS, OTHER THAN FOR THOSE LUMINAIRES MOUNTED ON TRAFFIC SIGNAL MAST ARM POLES, ARE TO BE PHOTOCELL ACTIVATED BY A PHOTOCELL ON THE LIGHTING CONTROL CABINET. LUMINAIRES INSTALLED ON TRAFFIC SIGNAL MAST ARM POLES SHALL BE PHOTOCELL ACTIVATED BY A PHOTOCELL ON THE TRAFFIC SIGNAL CONTROL CABINET.

8. NEW LIGHTING FIXTURE VOLTAGE SHALL BE 240 VOLTS.

9. LIGHTING FIXTURES SHALL BE IES FULL CUTOFF, LIGHT EMITTING DIODE (LED) FIXTURES, IES DISTRIBUTION TYPE 2 AND TYPE 3. LED MODULES SHALL BE IP66 RATED.

10. ALL FIXTURES SHALL BE GASKETED AND HAVE SURGE PROTECTION AND A DOUBLE FUSE KIT. ALL FIXTURES SHALL BE BLACK.

11. THE LIGHTING LAYOUT AT THE WILLIAM CLARKE DRIVE INTERSECTIONS AT MAIN STREET AND SACO STREET WAS DONE USING AMERICAN ELECTRIC LIGHTING 'AUTOBAHN' SERIES ATBO LUMINAIRES, CATALOG NUMBERS:  
 ATBO P204 R3 4K, 2 LUMINAIRES ON 2 TRAFFIC SIGNAL MAST ARM POLES  
 ATBO P202 R2 4K, 1 LUMINAIRE ON 1 TRAFFIC SIGNAL MAST ARM POLE  
 ATBO P202 R3 4K, 2 LUMINAIRES ON 2 TRAFFIC SIGNAL MAST ARM POLES

12. THE ORNAMENTAL LIGHTING LAYOUT ALONG WILLIAM CLARKE DRIVE WAS DONE USING ZUMA LIGHTING LLC ARCHITECTURAL SERIES "PREMIER" LED LUMINAIRES, 28-INCH DIAMETER, CATALOG NUMBERS:  
 PRM 70W U 4K T3 A 28 BK S, 22 LUMINAIRES ON 22 ORNAMENTAL POLES  
 PRM 70W U 4K T3 B 28 BK S, 2 LUMINAIRES ON 1 ORNAMENTAL POLE

13. LED COLOR TEMPERATURE FOR ALL NEW FIXTURES INSTALLED SHALL BE 4000K.

14. INSTALL SINGLE ORNAMENTAL LUMINAIRES (22 TOTAL) ON 22-FOOT ORNAMENTAL STEEL POLES AT A NOMINAL FIXTURE MOUNTING HEIGHT OF 22 FEET ABOVE ROADWAY GRADE. INSTALL DOUBLE ORNAMENTAL LUMINAIRES (1 PAIR TOTAL) ON A 26.5-FOOT ORNAMENTAL STEEL POLE AT A NOMINAL FIXTURE MOUNTING HEIGHT OF 26.5 FEET ABOVE ROADWAY GRADE.

15. FIXTURES SHALL ATTACH TO TRAFFIC SIGNAL MAST ARM POLES BY A MINIMAL LENGTH HORIZONTAL GALVANIZED STEEL PIPE TENON, 2-INCH NOMINAL DIAMETER. INSTALLATION ON BRACKET ARMS WILL NOT BE ALLOWED. INSTALL 'AUTOBAHN' LUMINAIRES AT A NOMINAL MOUNTING HEIGHT OF 25 FEET ABOVE ROADWAY GRADE.

16. ORNAMENTAL LIGHTING POLES SHALL BE ZUMA LIGHTING LLC ARCHITECTURAL POLES, ROUND STEEL, POWDER COATED BLACK. POLES SHALL MEET REQUIREMENTS OF THE 2015 EDITION, AS AMENDED, OF AASHTO PUBLICATION "LRFD SPECIFICATIONS FOR STRUCTURAL SUPPORTS FOR HIGHWAY SIGNS, LUMINAIRES AND TRAFFIC SIGNALS" AND OF THE MAINEDOT STANDARD SPECIFICATIONS. CALCULATIONS MUST BE SUBMITTED DOCUMENTING COMPLIANCE FOR THE SERVICE, STRENGTH AND EXTREME LOAD COMBINATION LIMIT STATES, WITH A 1700 YEAR MRI WIND SPEED OF 130 MPH, 10 YEAR GUST SPEED OF 76 MPH, AND A MINIMUM GUST EFFECT FACTOR OF 1.14. FOR POLE DESIGN PURPOSES, DESIGN WEIGHT OF ATTACHED LIGHTING FIXTURES SHALL BE ASSUMED TO BE 60 POUNDS OR THE ACTUAL WEIGHT, WHICHEVER IS GREATER, AND THE EPA OF FIXTURES SHALL BE 5.0 SQUARE FEET OR THE ACTUAL EPA, WHICHEVER IS GREATER. MAXIMUM ALLOWABLE HORIZONTAL POLE DEFLECTION WILL BE 5% OF THE POLE HEIGHT WITH A SUPPLEMENTAL 500 POUND TRANSVERSE LOAD APPLIED AT 18 INCHES FROM THE POLE TOP. ORNAMENTAL POLE DIAMETER AND WALL THICKNESS SHALL BE AS DETERMINED BY THE MANUFACTURER TO SUPPORT DESIGN LOADING FOR COMPLIANCE WITH THE SPECIFICATIONS. MINIMUM ALLOWABLE DIAMETER SHALL BE 5 INCHES.

17. ARMS FOR MOUNTING OF ORNAMENTAL LIGHTING FIXTURES SHALL BE ZUMA LIGHTING LLC ARCHITECTURAL ARMS, CATALOG NUMBER AT06 WITH FLAT CAPS. POLE BASES FOR ORNAMENTAL POLES SHALL BE ZUMA LIGHTING LLC ARCHITECTURAL BASES, 39-INCH HEIGHT, CATALOG NUMBER AB03.

18. CONTACT INFORMATION FOR THE REGIONAL DISTRIBUTOR FOR ZUMA LIGHTING LLC IS:  
 CHRIS ROTHFUSS  
 XPOS R  
 6 SCOTT ROAD, UNIT A  
 HAMPTON, NH 03842  
 (603) 601-8080  
<https://exposure2lighting.com/>

19. POLES SHALL HAVE A MINIMUM OF FOUR ANCHOR BOLTS. TIGHTENING OF ANCHOR BOLT NUTS ON POLES WITH BREAKAWAY BASES SHALL BE AS RECOMMENDED BY THE BREAKAWAY BASE MANUFACTURER. FOR POLES WITHOUT BREAKAWAY BASES, SNUG-TIGHT CONDITION OF ANCHOR BOLTS SHALL BE DEFINED AS BETWEEN 20 AND 30 PERCENT OF THE VERIFICATION TORQUE VALUE DETERMINED BY THE FORMULA IN FHWA PUBLICATION NHI 05-036. ADDITIONAL TIGHTENING BEYOND SNUG-TIGHT CONDITION SHALL BE DONE IN ACCORDANCE WITH SECTION 634.05 OF THE MAINEDOT STANDARD SPECIFICATIONS.

20. FOUNDATIONS FOR ORNAMENTAL LIGHT POLES SHALL BE 24-INCH DIAMETER, 7-FEET LONG, AND SHALL MEET REQUIREMENTS OF STANDARD DETAIL 626(02) AND SECTION 626 OF THE MAINEDOT STANDARD SPECIFICATIONS. PAYMENT FOR FOUNDATIONS FOR ORNAMENTAL LIGHTING WILL BE MADE UNDER ITEM 626.421. IF THE BOLT CIRCLE OF THE POLES DESIGNED BY THE MANUFACTURER RESULTS IN CONFLICT BETWEEN ANCHOR BOLTS AND REQUIRED FOUNDATION REINFORCEMENT, THE FOUNDATION DIAMETER SHALL BE INCREASED TO 30 INCHES TO ACCOMMODATE THE ANCHOR BOLTS. FOUNDATION LENGTH SHALL REMAIN SEVEN FEET. IN THE EVENT THAT THE FOUNDATION DIAMETER IS INCREASED, PAYMENT WILL BE MADE UNDER ITEM 626.421 AT A NOMINAL FOUNDATION LENGTH OF 11 FEET.

21. NEW POWER SERVICE CONDUIT REQUIRED BETWEEN THE POWER SOURCE AND THE METER SHALL BE RIGID METAL CONDUIT. OTHER NEW BURIED CONDUIT SHALL BE 2 INCH MINIMUM DIAMETER. REQUIREMENT OF LARGER CONDUIT SIZE SHALL BE DETERMINED BY THE CONTRACTOR IN ACCORDANCE WITH CONDUIT FILL REQUIREMENTS OF THE NATIONAL ELECTRICAL CODE. ALL CONDUIT IN THE HIGHWAY RIGHT OF WAY SHALL BE SCHEDULE 80 UNLESS CONCRETE-ENCASED. IF SCHEDULE 40 PVC CONDUIT ENCASED IN CONCRETE IS USED, CONCRETE ENCASEMENT WILL BE INCIDENTAL TO PAYMENT FOR CONDUIT.

22. CONDUIT UNDER EXISTING PAVEMENT THAT OTHERWISE IS NOT SHOWN ON THE PLANS TO BE DISTURBED BY ROADWAY RECONSTRUCTION SHALL BE HYDRAULICALLY JACKED OR DIRECTIONAL BORED TO AT LEAST TEN FEET BEYOND THE EDGE OF PAVEMENT. CONDUIT INSTALLED UNDER PAVEMENT WILL BE PAID UNDER ITEM 626.251 FOR THE PAVEMENT WIDTH PLUS 20 FEET. NO TRENCHING ACROSS EXISTING PAVED ROADWAY LANES OR SHOULDERS WILL BE ALLOWED. MINIMUM BURIAL DEPTH FOR ALL CONDUIT SHALL BE 36 INCHES.

23. BUSHINGS SHALL BE INSTALLED ON ALL CONDUIT TERMINATIONS.

24. PULL WIRE SHALL BE INSTALLED IN ALL NEW CONDUIT.

25. ALL EXPOSED RIGID CONDUIT FITTINGS AND HARDWARE SHALL BE GALVANIZED, EXCEPT NON-CONDUCTIVE BUSHINGS FOR CONNECTION OF RIGID METAL CONDUIT TO ALUMINUM CABINETS.

26. SECONDARY CIRCUIT WIRING SHALL BE STRANDED COPPER XHHW-2. ALL WIRING SHALL BE NO. 8 AWG OR LARGER WIRE SIZE. WIRE SIZES NOTED ON THE PLANS ARE APPROXIMATE. FINAL WIRE SIZING SHALL BE PERFORMED BY THE CONTRACTOR IN CONFORMANCE WITH N.E.C. REQUIREMENTS BASED ON ELECTRICAL LOADS OF ACTUAL ELECTRICAL COMPONENTS TO BE INSTALLED.

27. THE WIRE IN CONDUITS SHALL BE CONTINUOUS WITH NO SPLICES BETWEEN POLES. JUNCTION BOXES SHOWN ON THE PLANS ARE SHOWN IN APPROXIMATE LOCATIONS AND ARE INTENDED FOR USE ONLY AS PULL BOXES FOR WIRE PULLING ACCESS UNLESS OTHERWISE NOTED. ACTUAL NUMBER AND LOCATIONS MAY VARY AND SHALL BE SUBJECT TO APPROVAL OF THE RESIDENT PRIOR TO INSTALLATION.

28. CAP AND/OR SEAL EXPOSED ENDS OF CONDUIT TO PREVENT INTRUSION OF MOISTURE OR RODENTS. PAYMENT FOR CONDUIT OTHER THAN SERVICE CONDUIT WILL BE MADE UNDER ITEM 626.22, EXCEPT CONDUIT JACKED OR DIRECTIONAL BORED UNDER EXISTING PAVEMENT AND EXTENDING TO 20 FEET BEYOND THE EDGE OF PAVEMENT WILL BE PAID UNDER ITEM 626.251.

29. BREAKAWAY DEVICES SHALL CONFORM TO THE LATEST VERSION OF "AASHTO STANDARD SPECIFICATIONS FOR STRUCTURAL SUPPORTS FOR HIGHWAY SIGNS, LUMINAIRES AND TRAFFIC SIGNALS" AND NCHRP REPORT 350. THE BREAKAWAY DEVICE SHALL BE DESIGNED SO THAT THE ANCHOR BOLTS WILL NOT BEND WHEN A VEHICLE HITS THE POLE. A FRANGIBLE COUPLING SUCH AS TRANSPO POLE-SAFE 5000 SERIES (WITH A FEMALE ANCHOR), THE MANITOBA SAFETY BASE WITH REACTION PLATE, OR APPROVED EQUAL SHALL BE USED.

30. ALL LIGHT POLES SHALL BE BONDED TO THE GROUNDING CONDUCTOR.

31. METAL FRAMES AND CONDUCTIVE COVERS OF JUNCTION BOXES SHALL BE BONDED TO THE GROUNDING CONDUCTOR.

32. ALL FOUNDATIONS FOR ORNAMENTAL LIGHTING STANDARDS SHALL HAVE A GROUND ROD LOCATED IN OR ADJACENT TO THE FOUNDATION THAT IS BONDED TO THE GROUNDING CONDUCTOR. THE GROUND WIRE FOR THE GROUND ROD SHALL EXIT THROUGH A HALF-INCH DIAMETER CONDUIT IN THE FOUNDATION. PAYMENT FOR GROUND RODS AND GROUND WIRE CONDUIT IN FOUNDATIONS SHALL BE INCLUDED IN ITEM 634.160, HIGHWAY LIGHTING.

33. PAYMENT UNDER ITEM 634.70, ORNAMENTAL LIGHTING, WILL INCLUDE BUT NOT BE LIMITED TO NEW POLES, LIGHTING FIXTURES, MOUNTING ARMS, ORNAMENTAL BASES, AND BREAKAWAY DEVICES.

34. PAYMENT UNDER ITEM 626.21, ITEM 626.22 AND ITEM 626.251 WILL INCLUDE BUSHINGS, FITTINGS, PULL WIRE, AND OTHER NECESSARY HARDWARE RELATED TO THE CONDUIT.

35. PAYMENT UNDER ITEM 634.160, HIGHWAY LIGHTING, WILL INCLUDE ALL MATERIALS, LABOR AND EQUIPMENT NECESSARY TO PROVIDE A FULLY FUNCTIONING HIGHWAY LIGHTING SYSTEM EXCEPT THOSE ITEMS TO BE PAID UNDER OTHER RELATED BID ITEMS IN THE CONTRACT.

36. CURING BOXES AND ALL REQUIRED CONCRETE TESTING LABOR, MATERIALS, AND EQUIPMENT WILL BE CONSIDERED INCIDENTAL TO PAYMENT UNDER SECTION 626 FOUNDATION ITEMS.

37. STATIONING SHOWN FOR LIGHTING RELATED ITEMS IS APPROXIMATE AND MAY BE ADJUSTED BY THE RESIDENT IN THE FIELD IN CONSULTATION WITH THE ENGINEER.

38. UPON COMPLETION OF THIS PROJECT, THE CONTRACTOR SHALL FURNISH TO MAINEDOT A SET OF AS-BUILT PLANS FOR FUTURE REFERENCE AND SYSTEM MAINTENANCE.

Date: 12/18/2021

Username: morin

Filename: ... \018\_Lighting Construction Notes.dgn Division: HIGHWAY

STATE OF MAINE  
DEPARTMENT OF TRANSPORTATION

02379700

WIN  
023797.00

HIGHWAY PLANS

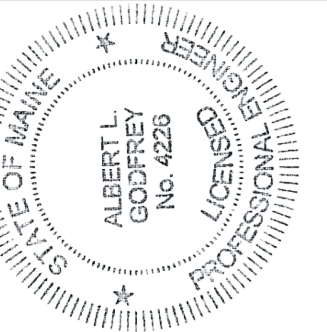

*Albert J. Morin*  
SIGNATURE  
4226  
P.E. NUMBER  
12/8/21  
DATE

PROJ. MANAGER	BRIAN KEIZER	BY	DATE
DESIGN-DETAILED	ALG	MSM	9-21
CHECKED-REVIEWED	ALG		9-21
DESIGN-DETAILED			
DESIGN-DETAILED			
REVISIONS 1			
REVISIONS 2			
REVISIONS 3			
REVISIONS 4			
FIELD CHANGES			

WESTBROOK  
WILLIAM CLARK DRIVE  
LIGHTING CONSTRUCTION NOTES

SHEET NUMBER

18

OF 46

**PAVEMENT MARKING NOTES:**

- ALL PAVEMENT MARKINGS SHALL BE IN CONFORMANCE WITH THE MANUAL ON TRAFFIC CONTROL DEVICES FOR STREETS AND HIGHWAYS, U.S. DOT, FHWA, 2009 EDITION, WITH THE LATEST REVISIONS.
- ALL PAVEMENT MARKING LINES, ARROWS, AND WORD SYMBOLS SHALL BE PAINT AND SHALL BE FURNISHED AND INSTALLED IN ACCORDANCE WITH MAINEDOT STANDARD SPECIFICATION 627.

**SIGNING NOTES**

- SALVAGED MATERIALS TO BECOME THE PROPERTY OF MAINEDOT AND DELIVERED TO THE REGION 1 OFFICE IN SCARBOROUGH.

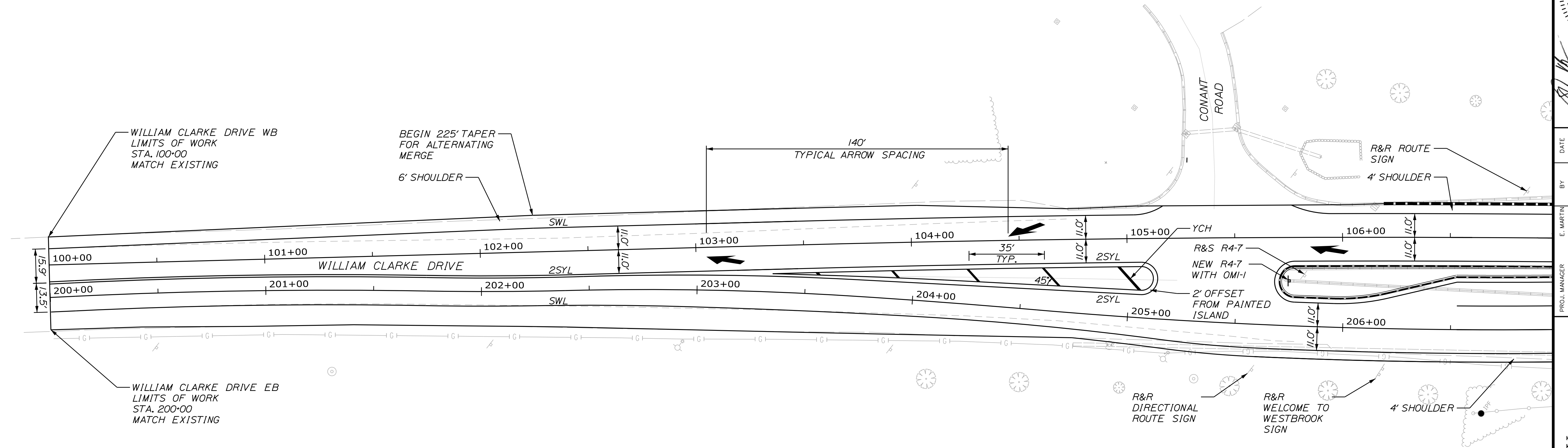

**PAVEMENT MARKING LEGEND**

2SYL	TWO SOLID YELLOW LINES (4")
SYL	SOLID YELLOW LINE (4")
SWL	SOLID WHITE LINES (4")
BWL	BROKEN WHITE LINE (4")
STOP BAR	STOP BAR (24")
YCH	CROSS HATCHING YELLOW (12")

NOTE: SEE TRAFFIC ENGINEERING STRIPING AND STENCILING HANDBOOK FOR FURTHER DETAILS ON PAVEMENT MARKINGS.

**SIGNING LEGEND**

R&S	REMOVE AND SALVAGE
R&R	REMOVE AND RESET
NEW	PROVIDE NEW SIGN

**LANE MARKING DETAILS**  
NOT TO SCALE

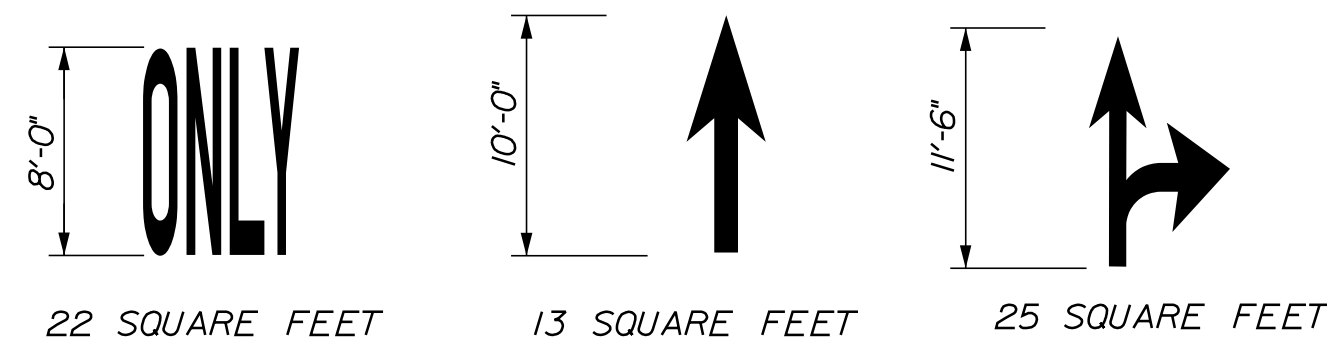

**SIGN LEGEND**  
NOT TO SCALE

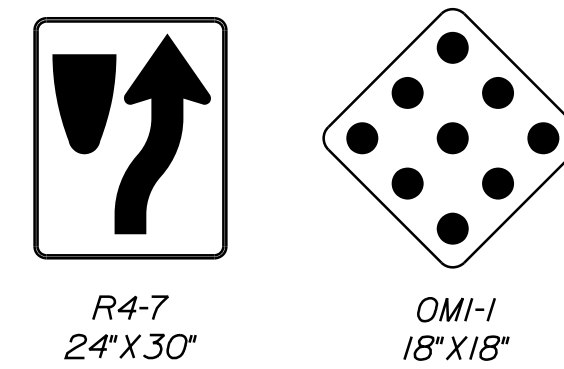

**CROSSWALK MARKING DETAIL**  
NOT TO SCALE

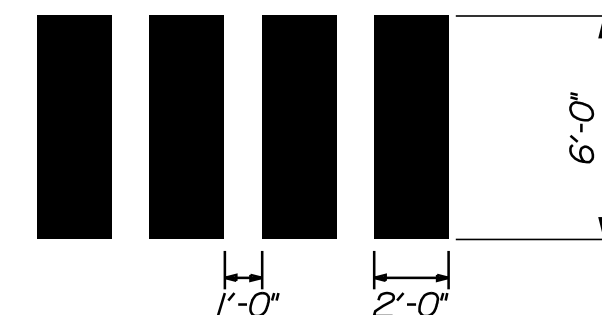

**BWL DETAIL**  
NOT TO SCALE

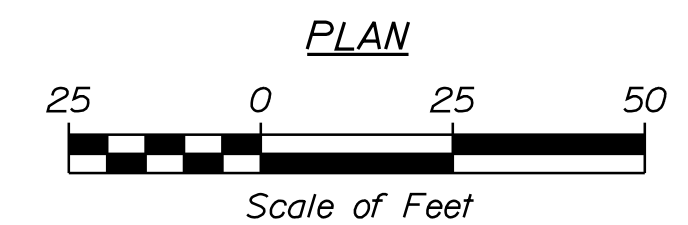
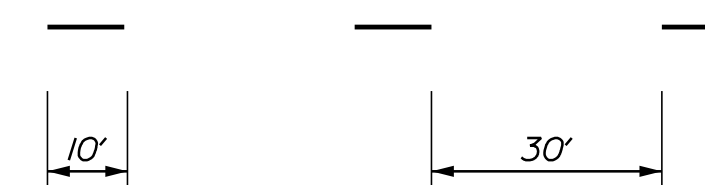

STATE OF MAINE  
DEPARTMENT OF TRANSPORTATION  
02379700  
WIN  
023797.00  
HIGHWAY PLANS

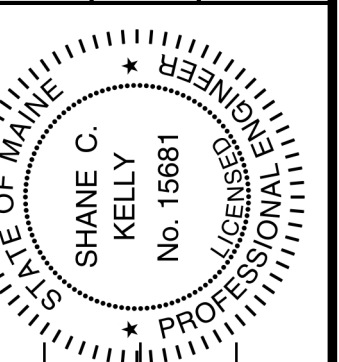

SIGNATURE: SHANE C. KELLY  
15681  
P.E. NUMBER: 15681  
DATE: 12/09/2021

PROJ. MANAGER	E. MARTIN
DESIGN-DETAILED	S. KELLY
CHECKED-REVIEWED	B. LYON
DATE	12/09/21
REVISIONS 1	
REVISIONS 2	
REVISIONS 3	

WESTBROOK  
WILLIAM CLARKE DRIVE  
STRIPING, MARKING & SIGNING PLAN

SHEET NUMBER

19

OF 46

Date: 12/19/2021

Username: skelly

Division: HIGHWAY

Filename: ... \019\_Pavement Marking Plan.dgn

Date: 12/19/2021

Username: skelly

Division: HIGHWAY

Filename: ... \020\_Pavement Marking Plan.dgn

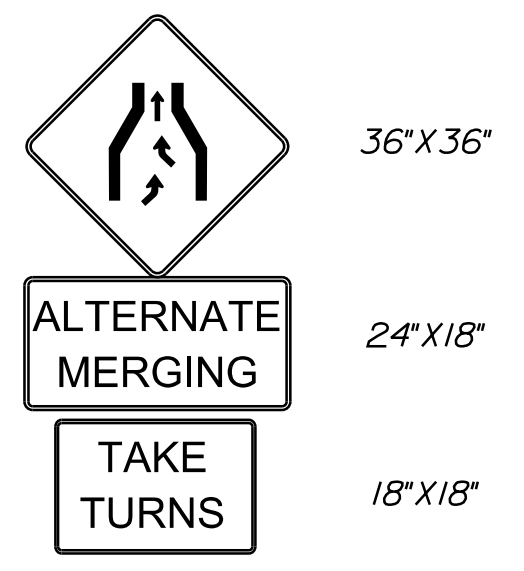
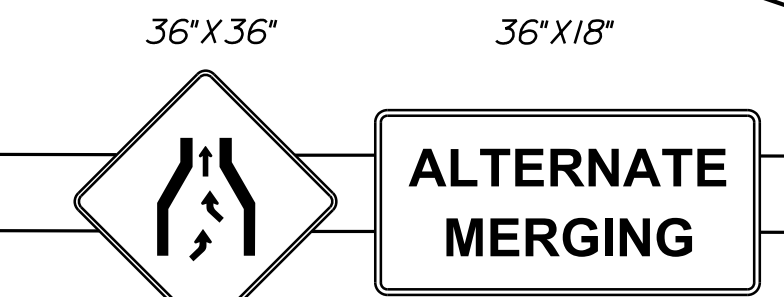
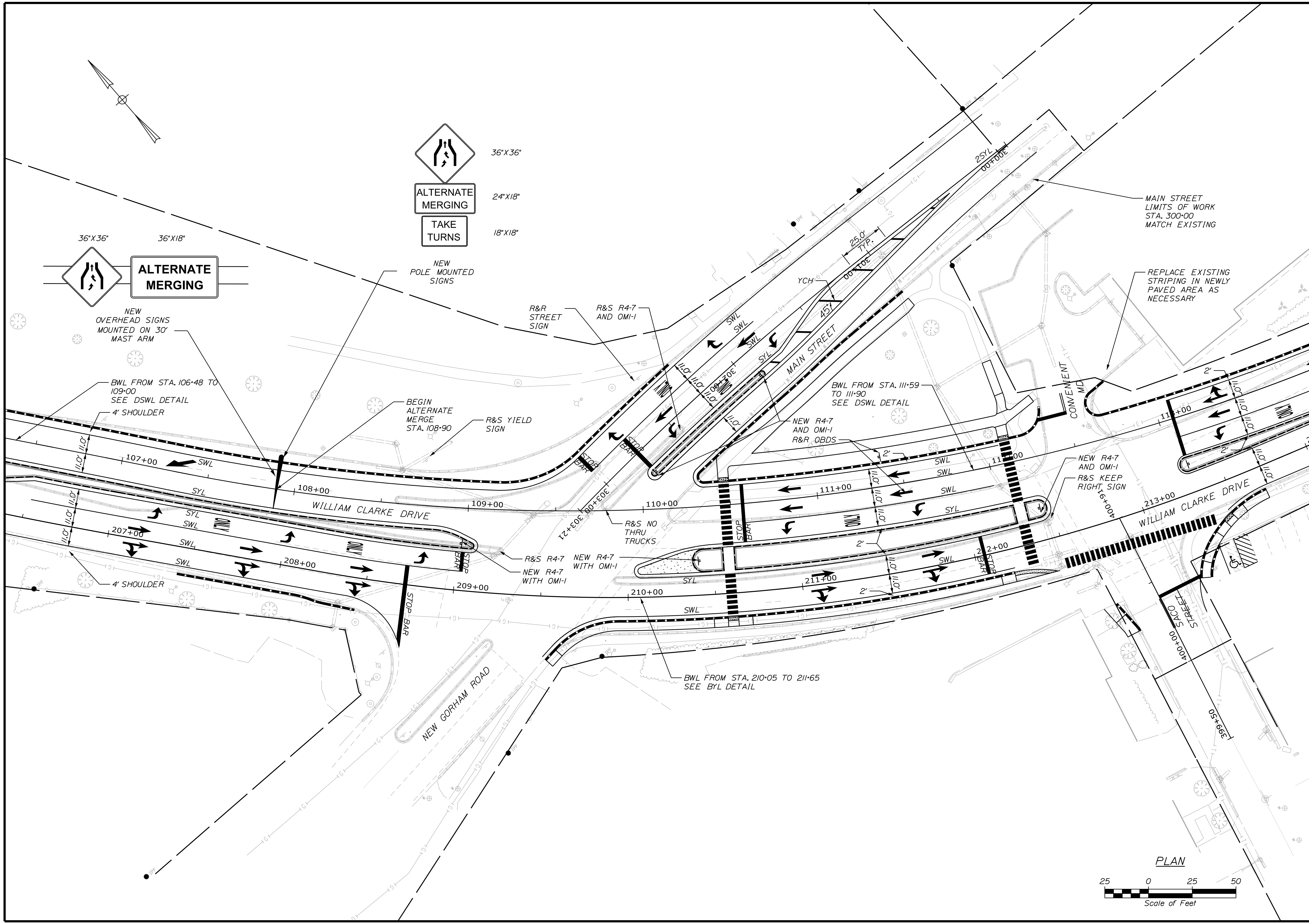

STATE OF MAINE DEPARTMENT OF TRANSPORTATION		02379700	WIN 023797.00	HIGHWAY PLANS
SIGNATURE	DATE	P.E. NUMBER	DATE	
SHANE C. KELLY	12/09/21	15681	12/09/2021	
DESIGN-DETAILED	BY	DATE	REVISIONS 1	
CHECKED-REVIEWED	E. MARTIN	12/09/21	REVISIONS 2	
	S. KELLY	12/09/21	REVISIONS 3	
	B. LYON	12/09/21		
<b>WESTBROOK CLARKE DRIVE</b> <b>STRIPING, MARKING &amp; SIGNING PLAN</b>		SHEET NUMBER <b>20</b> OF 46		

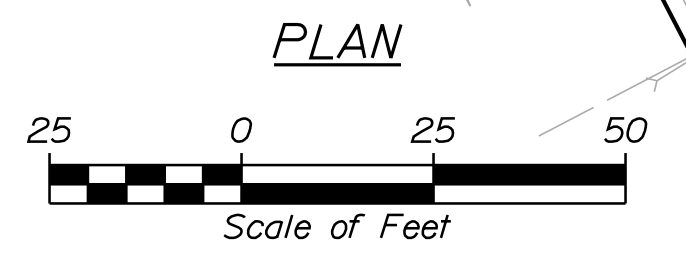

Date: 12/19/2021

Username: skelly

Division: HIGHWAY

Filename: ... \021\_Pavement Marking Plan.dgn

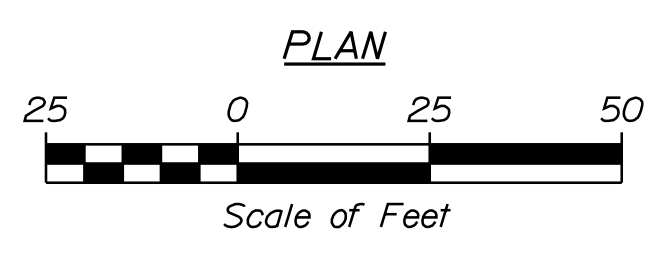
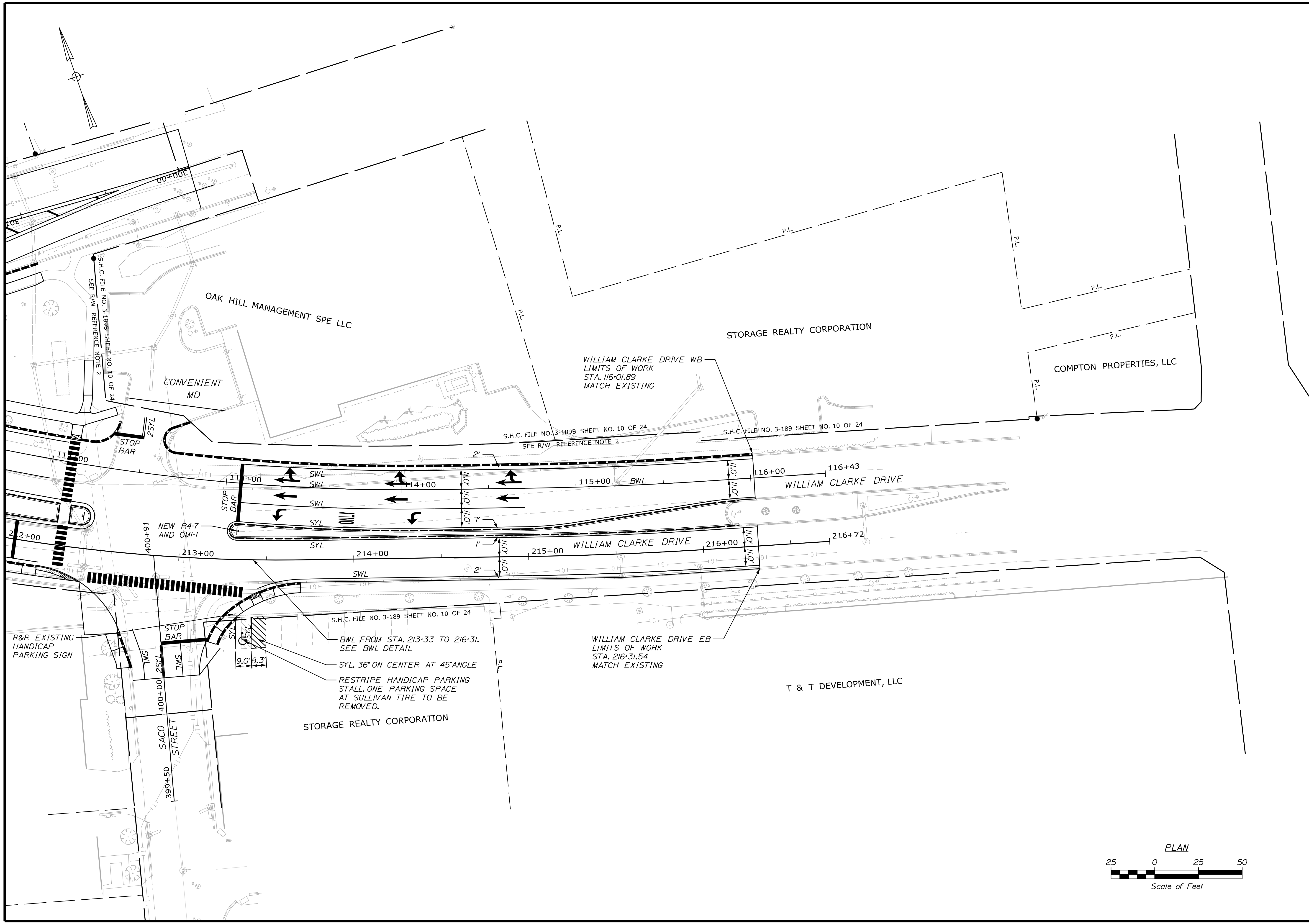

STATE OF MAINE DEPARTMENT OF TRANSPORTATION		02379700	
SIGNATURE SHANE C. KELLY No. 15681 PROFESSIONAL ENGINEER		DATE 12/09/21	
PROJ. MANAGER E. MARTIN		DATE 12/09/21	
DESIGN-DETAILED S. KELLY		BY S. KELLY	
CHECKED-REVIEWED B. LYON		BY B. LYON	
REVISIONS 1		P.F. NUMBER 15681	
REVISIONS 2		DATE 12/09/2021	
REVISIONS 3		DATE	
WESTBROOK WILLIAM CLARKE DRIVE		HIGHWAY PLANS WIN 023797.00	
STRIPING, MARKING & SIGNING PLAN		SHEET NUMBER 21 OF 46	

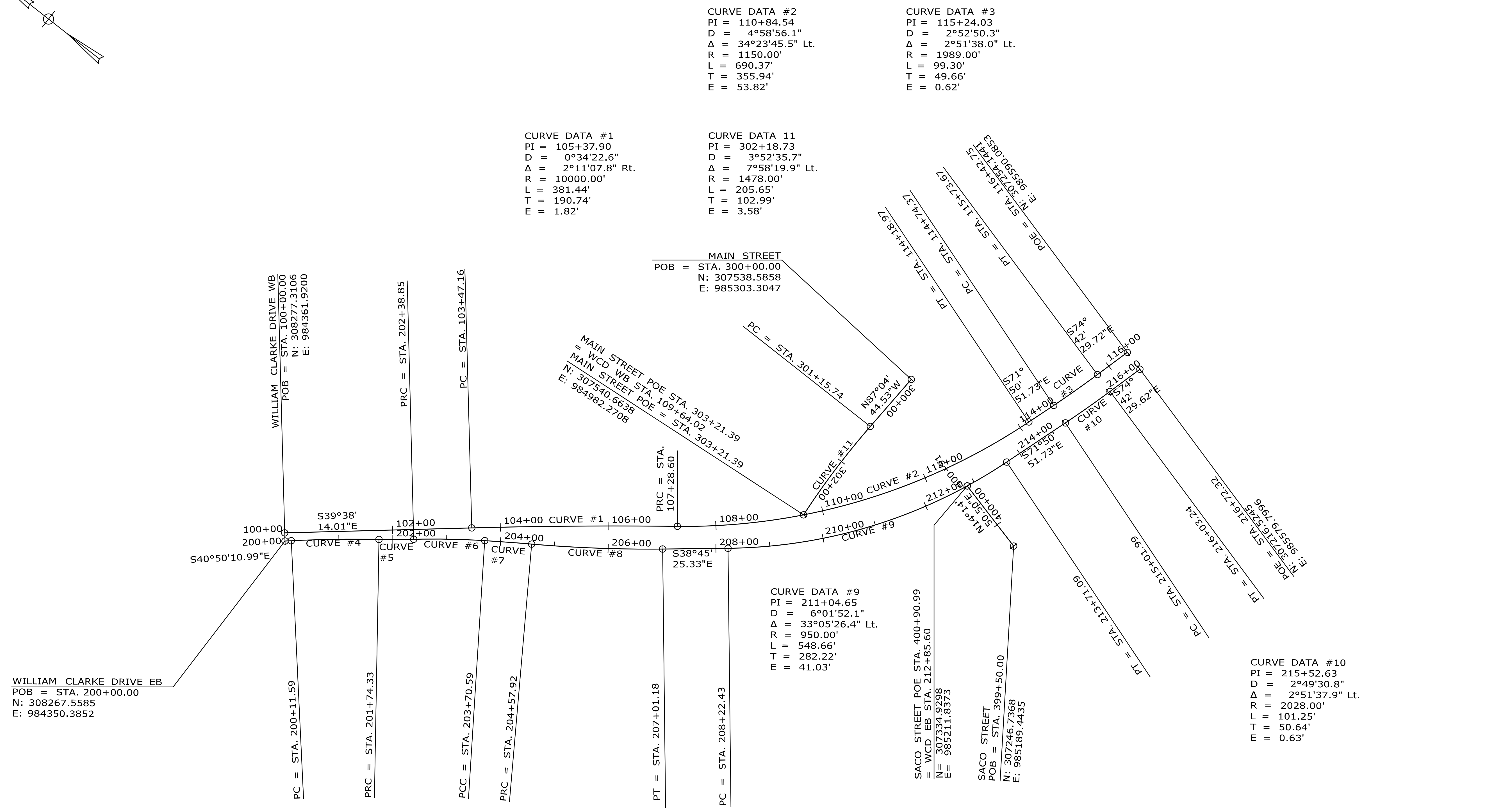
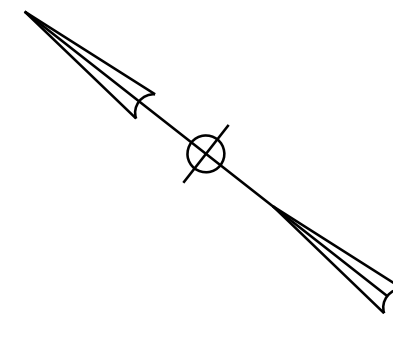

**CURVE DATA #4**  
 PI = 200+92.99  
 D = 2°17'54.6"  
 Δ = 3°44'26.2" Rt.  
 R = 2492.75'  
 L = 162.74'  
 T = 81.40'  
 E = 1.33'

**CURVE DATA #5**  
 PI = 202+06.59  
 D = 3°48'04.8"  
 Δ = 2°27'09.4" Lt.  
 R = 1507.25'  
 L = 64.52'  
 T = 32.26'  
 E = 0.35'

**CURVE DATA #6**  
 PI = 203+04.76  
 D = 3°49'11.0"  
 Δ = 5°01'55.4" Rt.  
 R = 1500.00'  
 L = 131.74'  
 T = 65.91'  
 E = 1.45'

**CURVE DATA #7**  
 PI = 204+14.25  
 D = 1°31'40.4"  
 Δ = 1°20'03.6" Rt.  
 R = 3750.00'  
 L = 87.33'  
 T = 43.67'  
 E = 0.25'

**CURVE DATA #8**  
 PI = 205+79.64  
 D = 2°17'30.6"  
 Δ = 5°34'30.2" Lt.  
 R = 2500.00'  
 L = 243.26'  
 T = 121.72'  
 E = 2.96'

**CURVE DATA #1**  
 PI = 105+37.90  
 D = 0°34'22.6"  
 Δ = 2°11'07.8" Rt.  
 R = 10000.00'  
 L = 381.44'  
 T = 190.74'  
 E = 1.82'

**CURVE DATA #11**  
 PI = 302+18.73  
 D = 3°52'35.7"  
 Δ = 7°58'19.9" Lt.  
 R = 1478.00'  
 L = 205.65'  
 T = 102.99'  
 E = 3.58'

**CURVE DATA #2**  
 PI = 110+84.54  
 D = 4°58'56.1"  
 Δ = 34°23'45.5" Lt.  
 R = 1150.00'  
 L = 690.37'  
 T = 355.94'  
 E = 53.82'

**CURVE DATA #3**  
 PI = 115+24.03  
 D = 2°52'50.3"  
 Δ = 2°51'38.0" Lt.  
 R = 1989.00'  
 L = 99.30'  
 T = 49.66'  
 E = 0.62'

**CURVE DATA #9**  
 PI = 211+04.65  
 D = 6°01'52.1"  
 Δ = 33°05'26.4" Lt.  
 R = 950.00'  
 L = 548.66'  
 T = 282.22'  
 E = 41.03'

**CURVE DATA #10**  
 PI = 215+52.63  
 D = 2°49'30.8"  
 Δ = 2°51'37.9" Lt.  
 R = 2028.00'  
 L = 101.25'  
 T = 50.64'  
 E = 0.63'

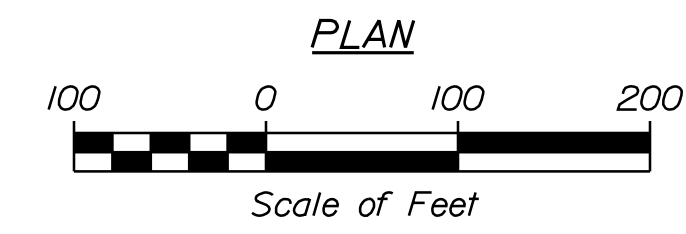

STATE OF MAINE DEPARTMENT OF TRANSPORTATION		02379700	WIN 023797.00	HIGHWAY PLANS
PROJ. MANAGER	E. MARTIN	BY	DATE	
DESIGN-DETAILED	S. KELLY	12/09/21		
CHECKED-REVIEWED	B. LYON	12/09/21		
REVISIONS 1				
REVISIONS 2				
REVISIONS 3				
SIGNATURE		15681	P.E. NUMBER	12/09/2021
DATE				
WESTBROOK WILLIAM CLARKE DRIVE		GEOMETRIC PLAN		
SHEET NUMBER				
22				
OF 46				

Date: 12/19/2021

Username: skelly

Division: HIGHWAY

Filename: ... \023\_Curb Plan.dgn

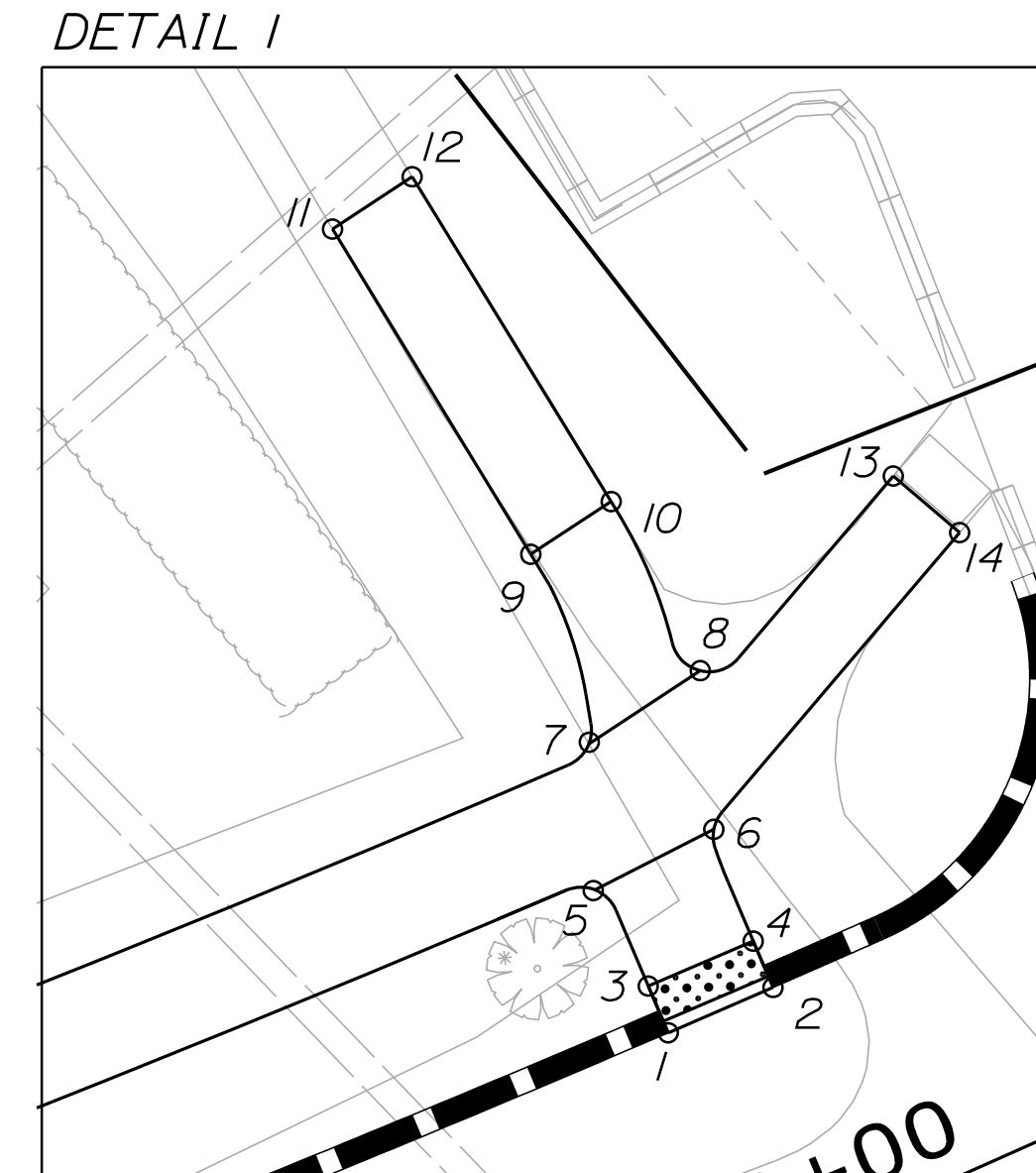
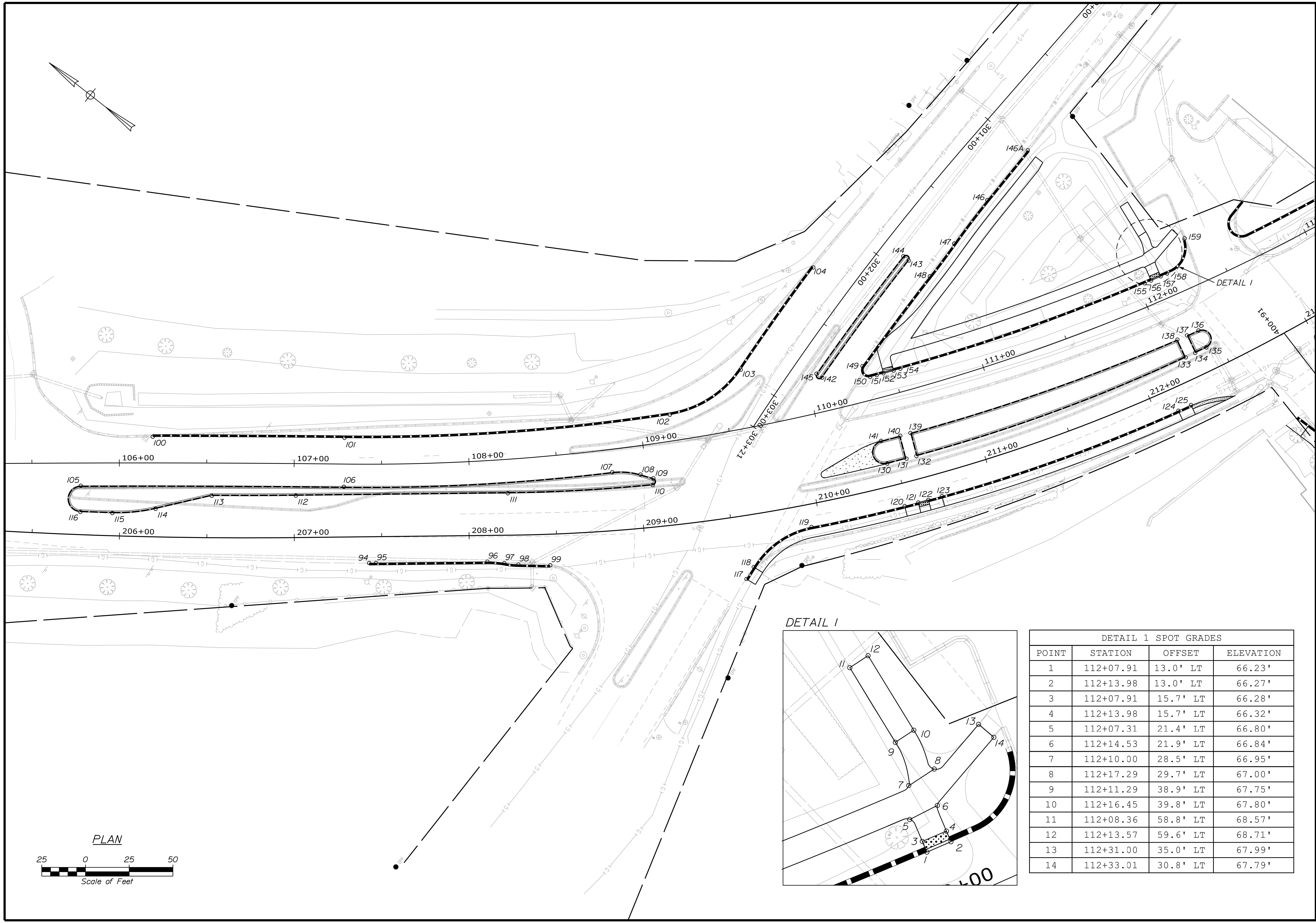
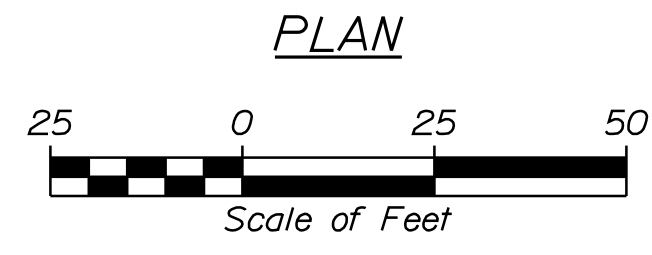
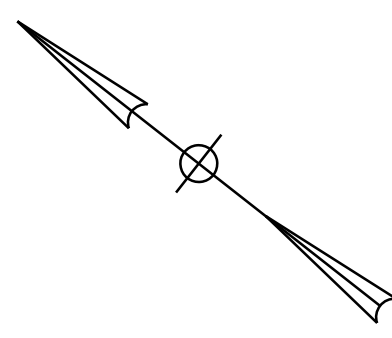

DETAIL 1 SPOT GRADES			
POINT	STATION	OFFSET	ELEVATION
1	112+07.91	13.0' LT	66.23'
2	112+13.98	13.0' LT	66.27'
3	112+07.91	15.7' LT	66.28'
4	112+13.98	15.7' LT	66.32'
5	112+07.31	21.4' LT	66.80'
6	112+14.53	21.9' LT	66.84'
7	112+10.00	28.5' LT	66.95'
8	112+17.29	29.7' LT	67.00'
9	112+11.29	38.9' LT	67.75'
10	112+16.45	39.8' LT	67.80'
11	112+08.36	58.8' LT	68.57'
12	112+13.57	59.6' LT	68.71'
13	112+31.00	35.0' LT	67.99'
14	112+33.01	30.8' LT	67.79'

STATE OF MAINE  
DEPARTMENT OF TRANSPORTATION

02379700

WIN  
023797.00

HIGHWAY PLANS

PROJ. MANAGER  
E. MARTIN

DESIGNED/DETAILED  
S. KELLY

CHECKED/REVIEWED  
B. LYON

DATE  
12/09/21

BY  
S. KELLY

DATE  
12/09/21

BY  
B. LYON

REVISIONS 1

REVISIONS 2

REVISIONS 3

SIGNATURE  
15681

P.E. NUMBER  
12/09/2021

DATE

WESTBROOK  
WILLIAM CLARKE DRIVE  
CURB LAYOUT PLANS

SHEET NUMBER

23

OF 46

CONTROL POINTS FOR WILLIAM CLARKE DR		
POINT	STATION	OFFSET
94	207+42.66	15.0' RT
95	207+46.66	12.0' RT
96	208+10.32	15.0' RT
97	208+20.00	16.0' RT
98	208+27.97	16.9' RT
99	208+45.87	17.8' RT
100	106+19.11	15.0' LT
101	107+28.60	15.0' LT
102	109+17.82	15.0' LT
105	105+77.92	13.0' RT
106	107+28.60	13.0' RT
107	108+80.72	13.0' RT
108	108+96.40	16.4' RT
109	109+03.27	19.6' RT
110	209+07.67	24.0' LT
111	208+22.47	24.0' LT
112	207+01.22	24.0' LT
113	206+52.65	24.0' LT
114	206+20.35	16.1' LT
115	205+95.62	13.0' LT
116	205+77.16	13.0' LT
117	209+53.85	36.0' RT
118	209+58.82	29.9' RT
119	209+94.57	13.0' RT
120	210+48.44	13.0' RT
121	210+56.33	13.0' RT
122	210+62.25	13.0' RT
123	210+70.14	13.0' RT
124	212+12.15	13.0' RT
125	121+20.15	13.0' RT
130	210+44.68	13.0' RT
131	210+56.19	13.0' RT
132	210+62.16	13.0' RT
133	212+28.73	13.0' RT
134	212+34.81	13.0' RT
135	212+41.99	13.0' RT
136	112+21.27	24.0' RT
137	112+14.30	24.0' RT
138	112+08.42	24.0' RT
139	110+49.80	24.0' RT

CONTROL POINTS FOR WILLIAM CLARKE DR		
POINT	STATION	OFFSET
140	110+43.92	24.0' RT
141	110+32.80	24.0' RT
150	110+35.83	13.0' LT
151	110+39.88	13.0' LT
152	110+43.92	13.0' LT
153	110+50.00	13.0' LT
154	110+54.00	13.0' LT
155	112+03.86	13.0' LT
156	112+07.91	13.0' LT
157	112+13.98	13.0' LT
158	112+18.02	13.0' LT
159	112+35.74	27.3' LT

CONTROL POINTS FOR MAIN STREET		
POINT	STATION	OFFSET
103	302+98.30	24.0' RT
104	302+27.69	24.0' RT
142	302+75.78	17.0' LT
143	301+91.48	17.0' LT
144	301+91.48	13.0' LT
145	302+75.78	13.0' LT
146	301+35.45	29.9' LT
146A	300+98.28	28.8' LT
147	301+67.22	31.3' LT
148	301+91.14	32.0' LT
149	302+56.77	32.0' LT



NEW CURB TYPE 1		
POINT TO POINT	RADIUS (FT)	LENGTH (LF)
95 to 96	-	63.7
98 to 99	-	18.1
100 to 101	10015	109.7
101 to 102	1135	186.8
102 to 103	60	49.5
103 to 104	1502	71.8
119 to 120	963	54.6
123 to 124	963	142.0
146 to 147	500	31.1
146 TO 146A	-	36.8
147 to 148	515	23.8
148 to 149	1446	64.2
150 to 151	1137	4.0
154 to 155	1137	148.1
SHEET SUBTOTAL (LF)		1004.1

NEW TERMINAL CURB TYPE 1		
POINT TO POINT	RADIUS (FT)	TOTAL (LF)
94 to 95	-	4
117 to 118	-	8
120 to 121	963	8
122 to 123	963	8
124 to 125	963	8
151 to 152	1137	4
153 to 154	1137	4
155 to 156	1137	4
157 to 158	1137	4
SHEET SUBTOTAL (EA)		52

NEW CURB TYPE 1 - CIRCULAR		
POINT TO POINT	RADIUS (FT)	LENGTH (LF)
96 to 97	50	9.7
97 to 98	50	8.12
118 to 119	50	41.5
149 to 150	4	9.8
158 to 159	15	23
SHEET SUBTOTAL (LF)		92.12

NEW CURB TYPE 5		
POINT TO POINT	RADIUS (FT)	LENGTH (LF)
105 to 106	9987	150.5
106 to 107	1163	153.8
107 to 108	40	16.4
108 to 109	-	7.7
110 to 111	926	83
111 to 112	-	121.3
112 to 113	2476	48.1
113 to 114	-	33
114 to 115	96	24.8
115 to 116	2487	18.4
130 to 131	937	11.5
131 to 140	-	13.5
140 to 141	1174	11.4
132 to 133	937	164.2
133 to 138	-	11.2
138 to 139	1174	161.9
139 to 132	-	13.6
134 to 135	937	7.1
137 to 134	-	11.0
142 to 143	1461	83.4
144 to 145	1465	83.6
SHEET SUBTOTAL (LF)		1236.5

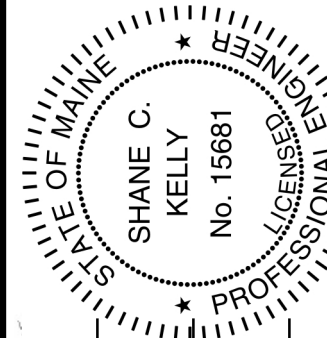
NEW CURB TYPE 5 - CIRCULAR		
POINT TO POINT	RADIUS (FT)	LENGTH (LF)
109 to 110	2	5.5
116 to 105	7.5	23.2
141 to 130	6.75	21.2
135 to 136	5.4	16.8
143 to 144	2	6.3
145 to 142	2	6.3
SHEET SUBTOTAL (LF)		79.3

STATE OF MAINE DEPARTMENT OF TRANSPORTATION		023797.00	WIN 023797.00	HIGHWAY PLANS
				
PROJ. MANAGER E. MARTIN	BY S. KELLY B. LYON	DATE 12/09/21 12/09/21	SIGNATURE 	P.E. NUMBER 15681
DESIGN-DETAILED	CHECKED-REVIEWED	REVISIONS 1	REVISIONS 2	REVISIONS 3
WESTBROOK WILLIAM CLARKE DRIVE		CURB LAYOUT PLANS		
SHEET NUMBER				
24				
OF 46				

Date: 12/19/2021

Username: skelly

Division: HIGHWAY

Filename: ... \025\_Curb Plan.dgn

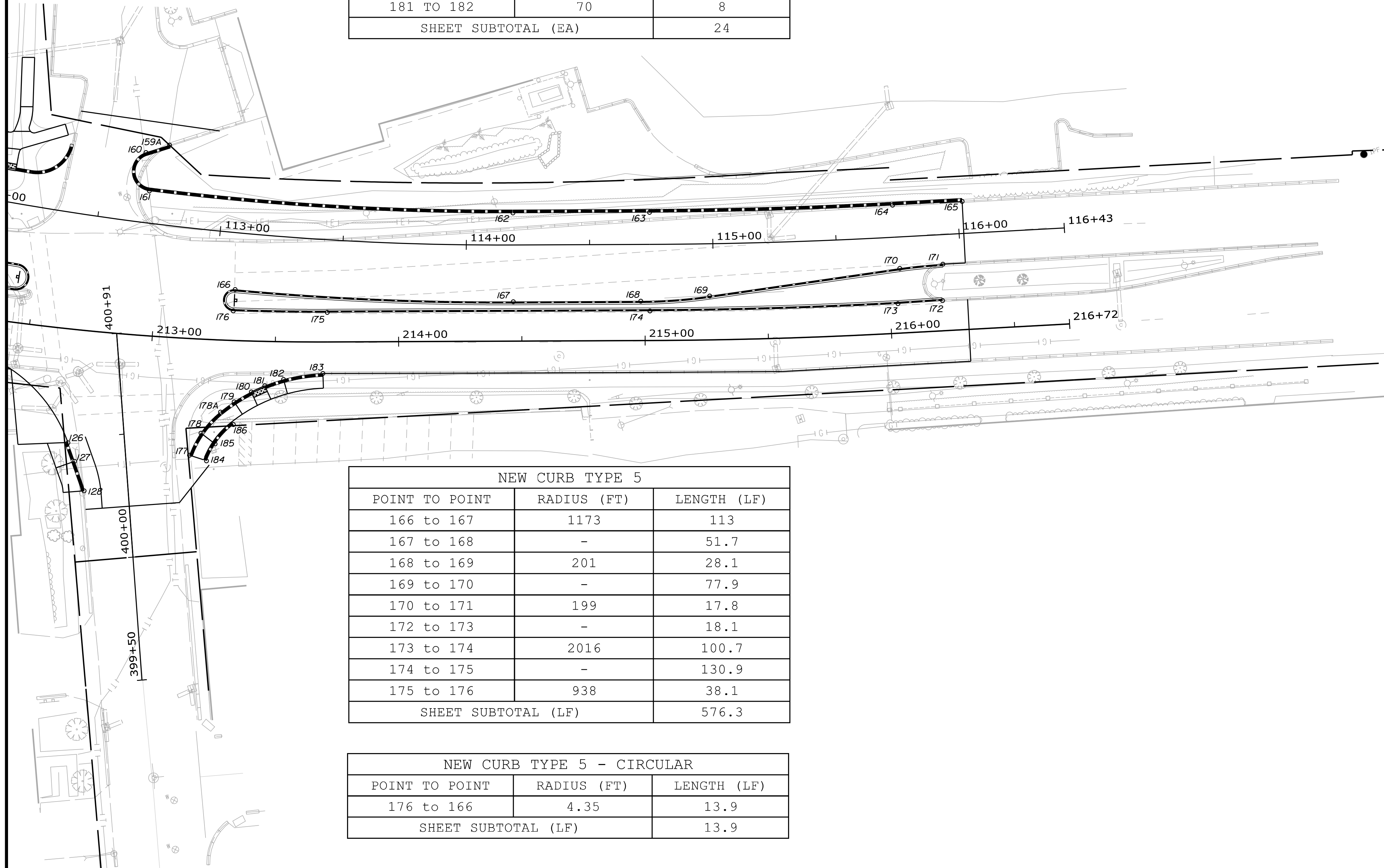
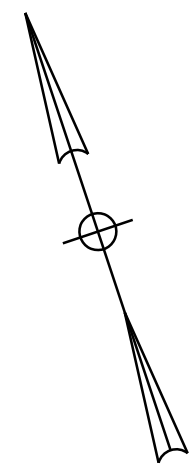

NEW CURB TYPE 1		
POINT TO POINT	RADIUS (FT)	LENGTH (LF)
159A TO 160	-	10.0
161 to 162	1137	147.8
162 to 163	-	55.4
163 to 164	1976	98.7
164 to 165	-	28.3
127 TO 128	-	12.3
178A TO 179	70	7
182 TO 183	70	16.2
<b>SHEET SUBTOTAL (LF)</b>		<b>375.7</b>

NEW CURB TYPE 1 - CIRCULAR		
POINT TO POINT	RADIUS (FT)	LENGTH (LF)
160 to 161	8	21.7
178 TO 178A	40	11.8
<b>SHEET SUBTOTAL (LF)</b>		<b>33.5</b>

NEW TERMINAL CURB TYPE 1 - CIRCULAR		
POINT TO POINT	RADIUS (FT)	TOTAL (LF)
177 TO 178	40	10
184 TO 185	40	10
<b>SHEET SUBTOTAL (EA)</b>		<b>20</b>

NEW TERMINAL CURB TYPE 1		
POINT TO POINT	RADIUS (FT)	TOTAL (LF)
126 TO 127	-	8
179 TO 180	70	8
181 TO 182	70	8
<b>SHEET SUBTOTAL (EA)</b>		<b>24</b>

NEW CURB TYPE 5		
POINT TO POINT	RADIUS (FT)	LENGTH (LF)
166 to 167	1173	113
167 to 168	-	51.7
168 to 169	201	28.1
169 to 170	-	77.9
170 to 171	199	17.8
172 to 173	-	18.1
173 to 174	2016	100.7
174 to 175	-	130.9
175 to 176	938	38.1
<b>SHEET SUBTOTAL (LF)</b>		<b>576.3</b>

NEW CURB TYPE 5 - CIRCULAR		
POINT TO POINT	RADIUS (FT)	LENGTH (LF)
176 to 166	4.35	13.9
<b>SHEET SUBTOTAL (LF)</b>		<b>13.9</b>

CONTROL POINTS FOR WILLIAM CLARKE DR		
POINT	STATION	OFFSET
126	400+48.21	22.9' LT
127	400+40.45	20.8' LT
128	400+28.27	17.8' LT
159A	112+75.40	32.4' LT
160	112+66.02	28.3' LT
161	112+69.44	13.0' LT
162	114+18.97	13.0' LT
163	114+74.37	13.0' LT
164	115+73.67	13.0' LT
165	116+01.94	13.0' LT
166	113+08.20	23.0' RT
167	114+18.97	23.0' RT
168	114+70.67	23.0' RT
169	114+98.38	21.2' RT
170	115+75.20	12.8' RT
171	115+92.75	12.0' RT
172	216+21.41	12.3' LT
173	216+03.28	12.0' LT
174	215+02.03	12.0' LT
175	213+71.13	12.0' LT
176	213+32.52	12.0' LT
177	400+39.56	25.9' RT
178	400+48.18	31.2' RT
178A	400+56.11	39.6' RT
179	400+59.83	45.5' RT
180	213+40.80	20.6' RT
181	213+46.09	18.0' RT
182	213+53.53	15.3' RT
183	213+69.24	12.8' RT
184	400+36.79	32.6' RT
185	400+43.37	36.6' RT
186	400+50.67	44.5' RT

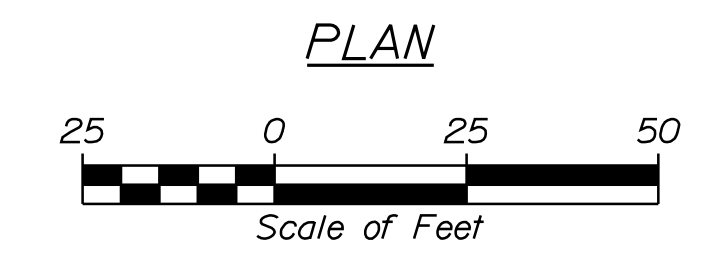

STATE OF MAINE  
DEPARTMENT OF TRANSPORTATION  
02379700  
WIN  
023797.00  
HIGHWAY PLANS

SHANE C. KELLY  
No. 15681  
PROFESSIONAL ENGINEER

SIGNATURE: [Signature]  
P.E. NUMBER: 15681  
DATE: 12/09/2021

PROJ. MANAGER	E. MARTIN
DESIGN-DETAILED	S. KELLY
CHECKED-REVIEWED	B. LYON
REVISIONS 1	
REVISIONS 2	
REVISIONS 3	

WESTBROOK  
WILLIAM CLARKE DRIVE  
CURB LAYOUT PLANS

SHEET NUMBER  
**25**  
OF 46



Date: 12/19/2021

Username: skelly

Division: HIGHWAY

Filename: ... \027\_GeneralPlan.dgn

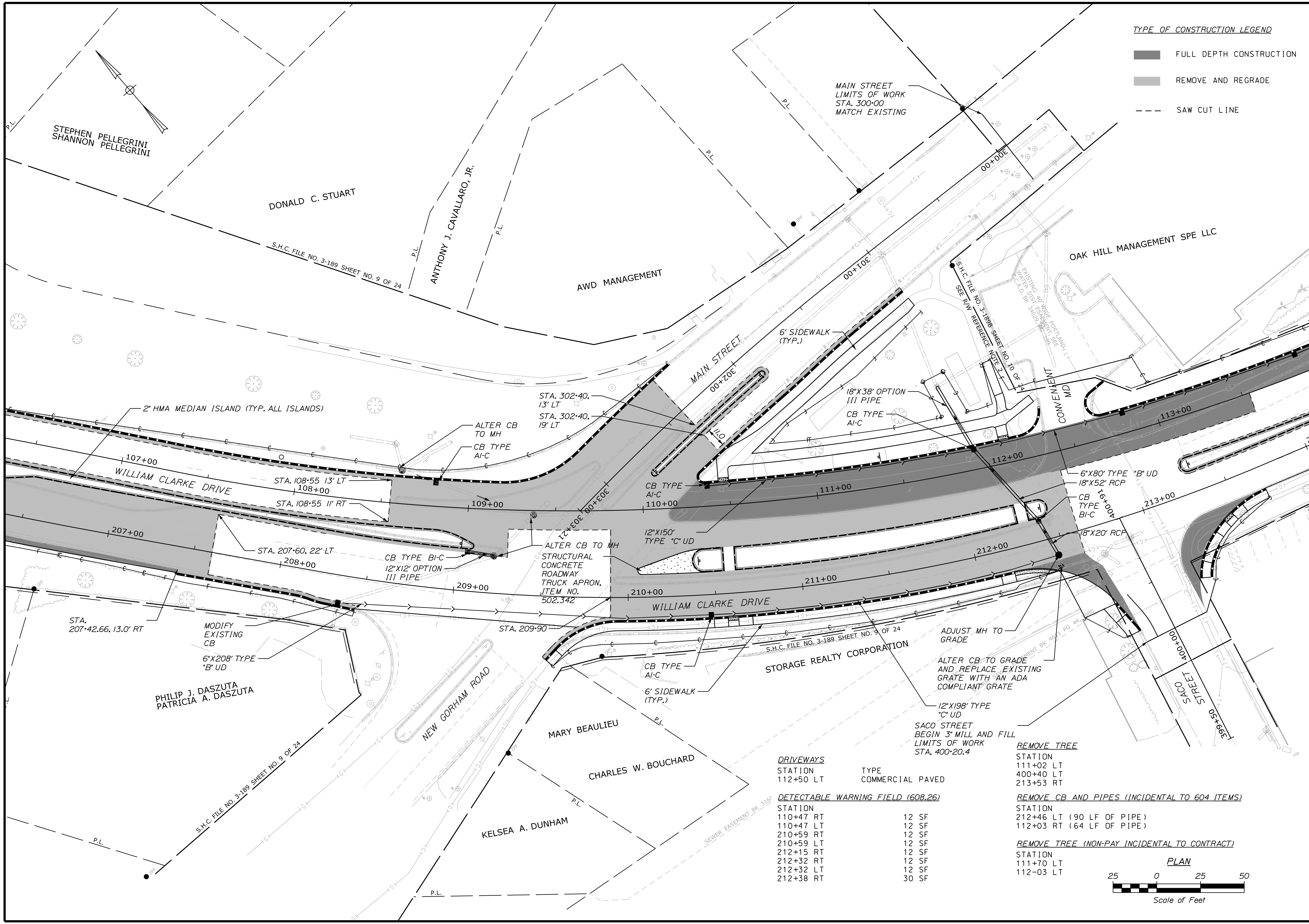

TYPE OF CONSTRUCTION LEGEND

	FULL DEPTH CONSTRUCTION
	REMOVE AND REGRADE
	SAW CUT LINE

STATE OF MAINE  
DEPARTMENT OF TRANSPORTATION  
02379700  
WIN  
023797.00  
HIGHWAY PLANS

PROFESSIONAL SEAL  
STATE OF MAINE  
SHANE C. KELLY  
No. 15681  
PROFESSIONAL ENGINEER

DATE	12/09/21
BY	S. KELLY
DESIGN-DETAILED	B. LYON
CHECKED-REVIEWED	E. MARTIN
REVISIONS 1	
REVISIONS 2	
REVISIONS 3	

WESTBROOK  
WILLIAM CLARKE DRIVE  
GENERAL PLAN

SHEET NUMBER  
**27**  
OF 46

DRIVEWAYS

STATION	TYPE
112+50 LT	COMMERCIAL PAVED

DETECTABLE WARNING FIELD (608.26)

STATION	TYPE	AREA
110+47 RT	12 SF	
110+47 LT	12 SF	
210+59 RT	12 SF	
210+59 LT	12 SF	
212+15 RT	12 SF	
212+32 RT	12 SF	
212+32 LT	12 SF	
212+38 RT	30 SF	

REMOVE TREE  
STATION  
111+02 LT  
400+40 LT  
213+53 RT

REMOVE CB AND PIPES (INCIDENTAL TO 604 ITEMS)  
STATION  
212+46 LT (90 LF OF PIPE)  
112+03 RT (64 LF OF PIPE)

REMOVE TREE (NON-PAY INCIDENTAL TO CONTRACT)  
STATION  
111+70 LT  
112-03 LT

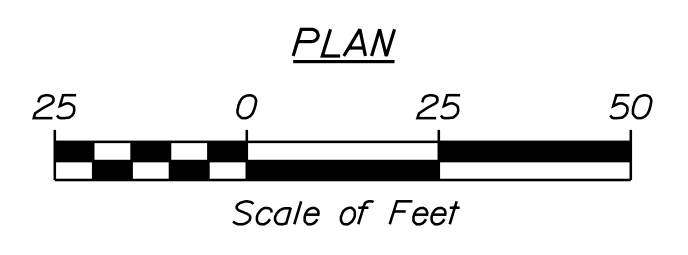

Date: 12/19/2021

Username: skelly

Division: HIGHWAY

Filename: ... \028\_GeneralPlan.dgn

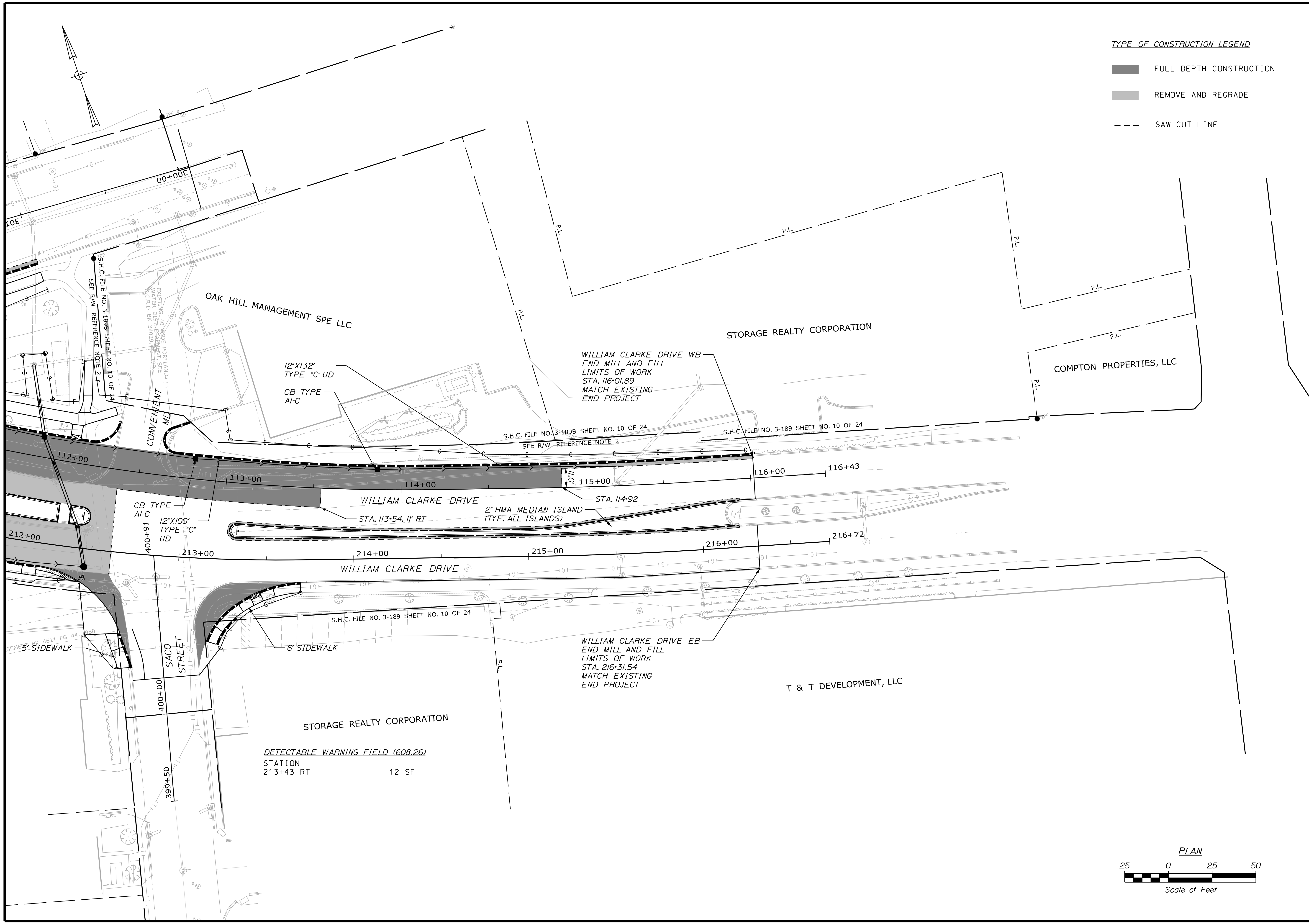

**TYPE OF CONSTRUCTION LEGEND**

	FULL DEPTH CONSTRUCTION
	REMOVE AND REGRADE
	SAW CUT LINE

STATE OF MAINE DEPARTMENT OF TRANSPORTATION		02379700	WIN 023797.00	HIGHWAY PLANS
SIGNATURE SHANE C. KELLY	DATE 12/09/21	P.E. NUMBER 15681	DATE 12/09/2021	
PROJ. MANAGER E. MARTIN	BY S. KELLY B. LYON	DESIGN-DETAILED	CHECKED-REVIEWED	REVISIONS 1 REVISIONS 2 REVISIONS 3
WESTBROOK WILLIAM CLARKE DRIVE		GENERAL PLAN		
SHEET NUMBER		28		
		OF 46		

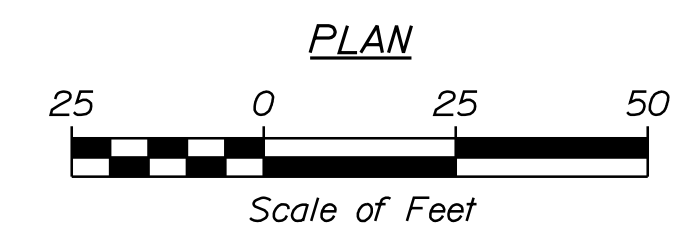

Date: 12/19/2021

Username: skelly

Division: HIGHWAY

Filename: ... \MSTA\Sheet Sets\Xsect.dgn

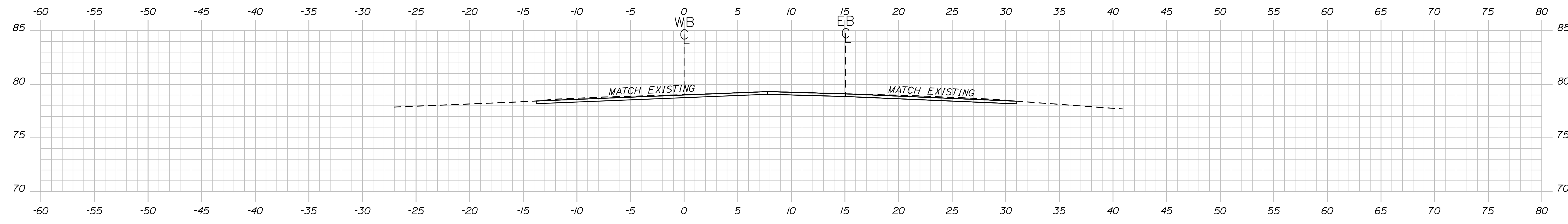

101+00.00

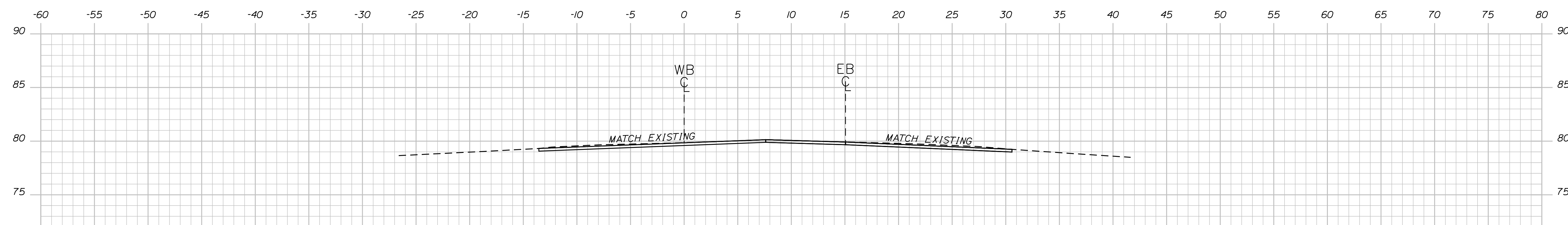

100+50.00

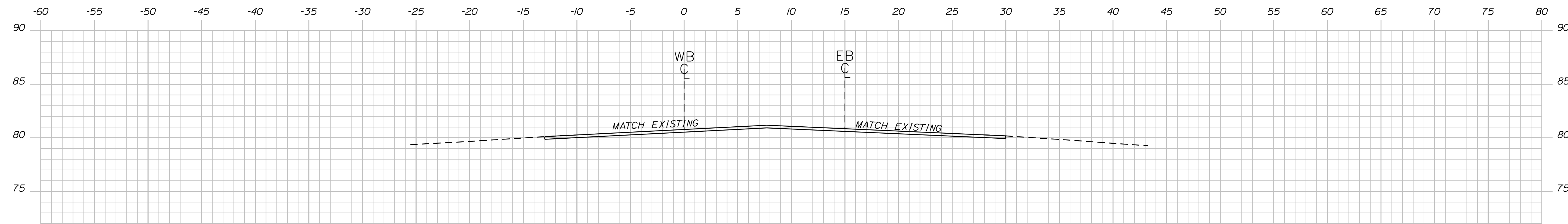

100+00.00

25 30 35  
WILLIAM CLARKE DRIVE WB  
BEGIN PROJECT STA. 100+00  
MATCH EXISTING

STATE OF MAINE  
DEPARTMENT OF TRANSPORTATION  
02379700  
WIN  
023797.00  
HIGHWAY PLANS

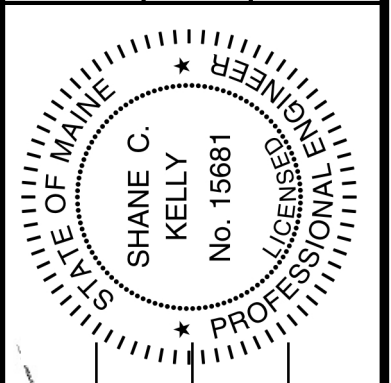

SIGNATURE  
P.E. NUMBER  
DATE

PROJ. MANAGER	DATE
DESIGN-DETAILED	12/09/21
CHECKED-REVIEWED	12/09/21
DESIGN-DETAILED	
DESIGN-DETAILED	
REVISIONS 1	
REVISIONS 2	
REVISIONS 3	
REVISIONS 4	
FIELD CHANGES	

WESTBROOK  
WILLIAM CLARKE DRIVE  
CROSS SECTIONS

SHEET NUMBER  
29  
OF 46

Date: 12/19/2021

Username: skelly

Division: HIGHWAY

Filename: ... \MSTA\Sheet Sets\Xsect.dgn

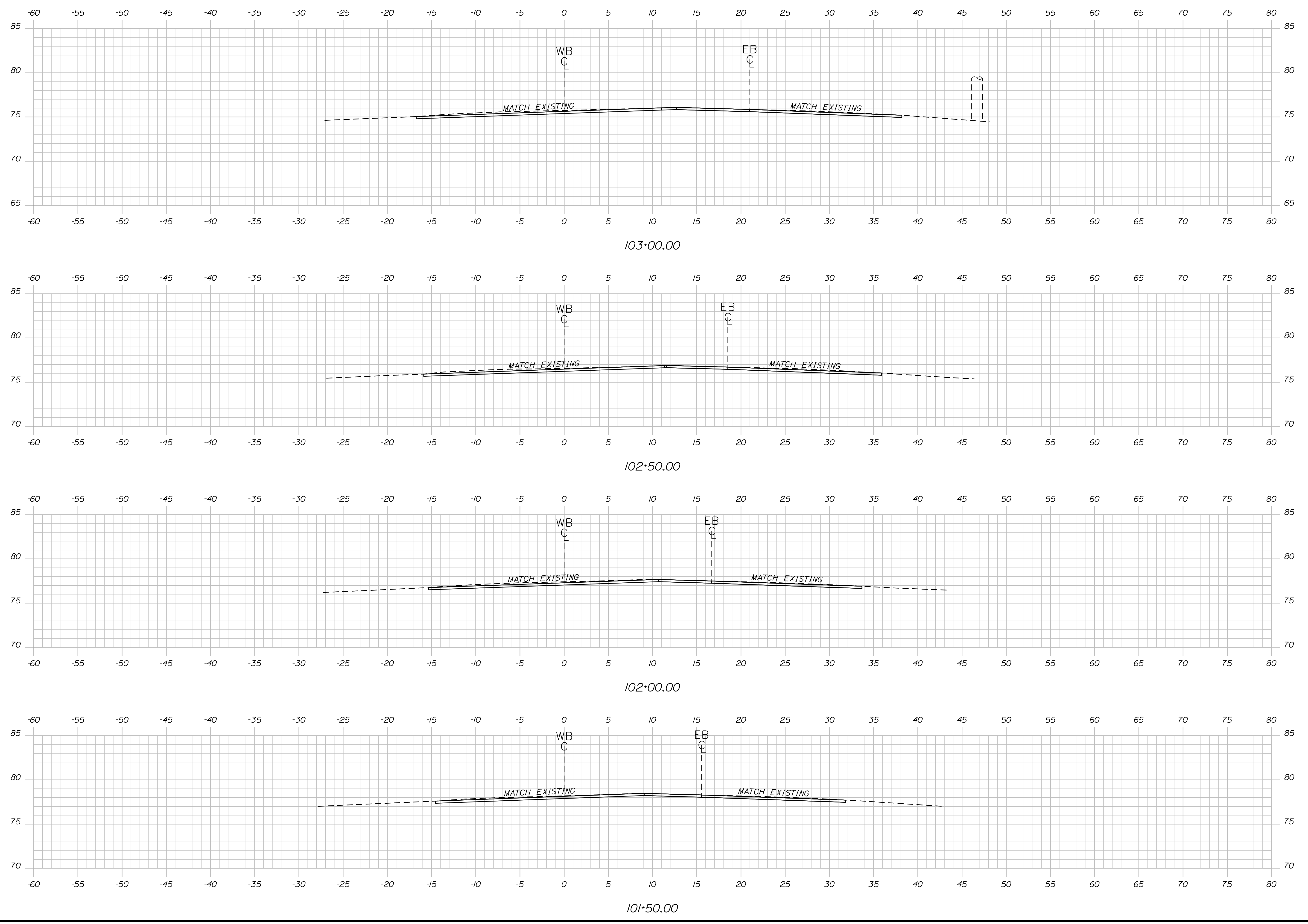

STATE OF MAINE  
DEPARTMENT OF TRANSPORTATION  
02379700  
WIN  
023797.00  
HIGHWAY PLANS

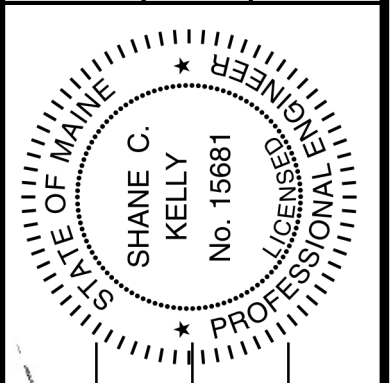

SIGNATURE  
SHANE C. KELLY  
No. 15681  
P.E. NUMBER  
12/09/2021  
DATE

PROJ. MANAGER	DATE
S. KELLY	12/09/21
B. LYON	12/09/21

DESIGN DETAILED	CHECKED/REVIEWED	DESIGN DETAILED	DESIGN DETAILED	REVISIONS 1	REVISIONS 2	REVISIONS 3	REVISIONS 4	FIELD CHANGES

WESTBROOK  
WILLIAM CLARKE DRIVE  
CROSS SECTIONS

SHEET NUMBER  
**30**  
OF 46

Date: 12/19/2021

Username: skelly

Division: HIGHWAY

Filename: ... \MSTA\Sheet Sets\Xsect.dgn

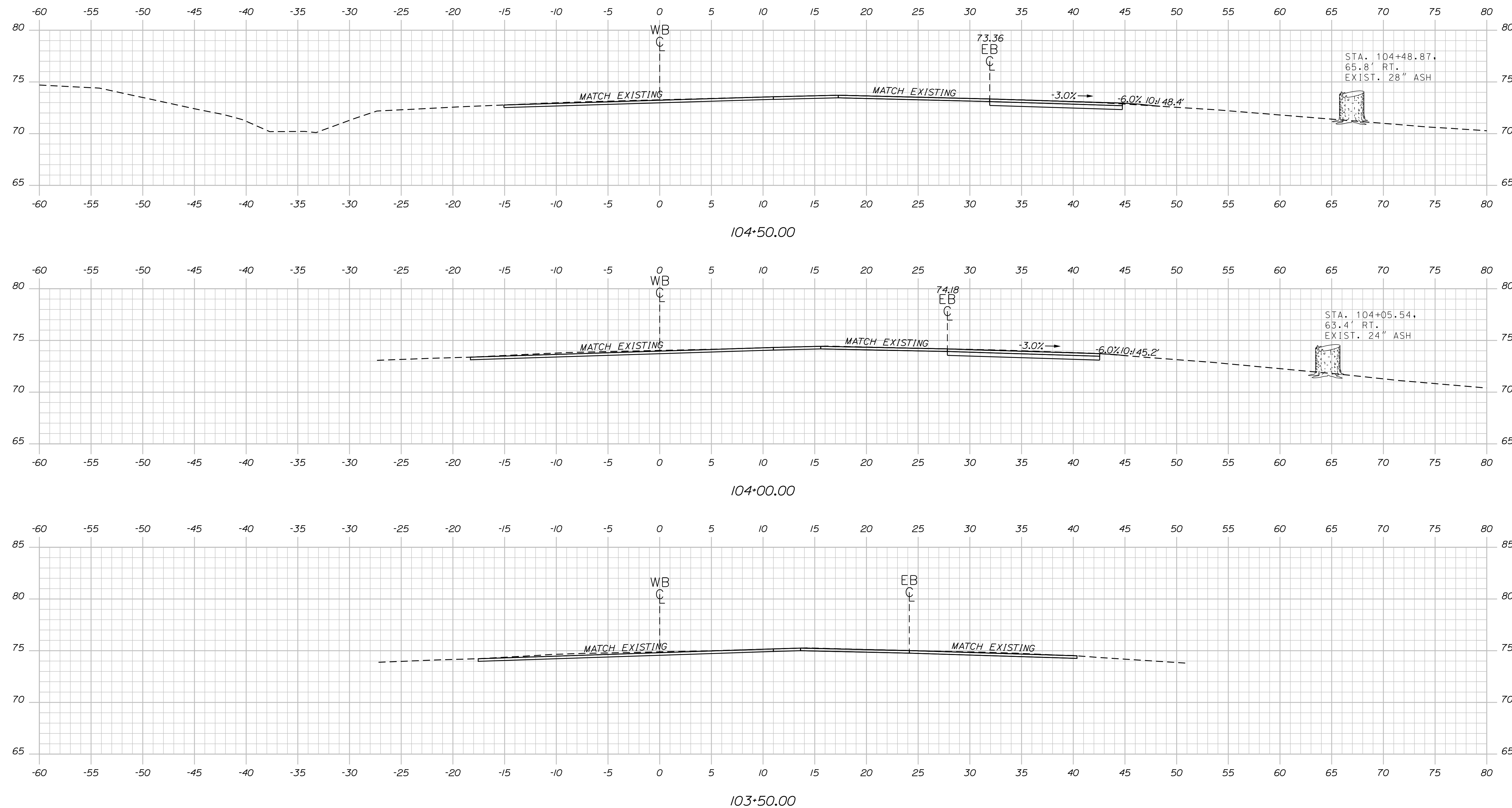

STATE OF MAINE  
DEPARTMENT OF TRANSPORTATION  
02379700  
WIN  
023797.00  
HIGHWAY PLANS

SHANE C. KELLY  
No. 15681  
PROFESSIONAL ENGINEER  
SIGNATURE  
15681  
P.E. NUMBER  
12/09/2021  
DATE

PROJ. MANAGER	E-MARTIN	BY	DATE
DESIGN-DETAILED		S. KELLY	12/09/21
CHECKED-REVIEWED		B. LYON	12/09/21
DESIGN-DETAILED			
DESIGN-DETAILED			
REVISIONS 1			
REVISIONS 2			
REVISIONS 3			
REVISIONS 4			
FIELD CHANGES			

WESTBROCK  
WILLIAM CLARKE DRIVE  
CROSS SECTIONS

SHEET NUMBER  
**31**  
OF 46

Date: 12/19/2021

Username: skelly

Division: HIGHWAY

Filename: ... \MSTA\Sheet Sets\Xsect.dgn

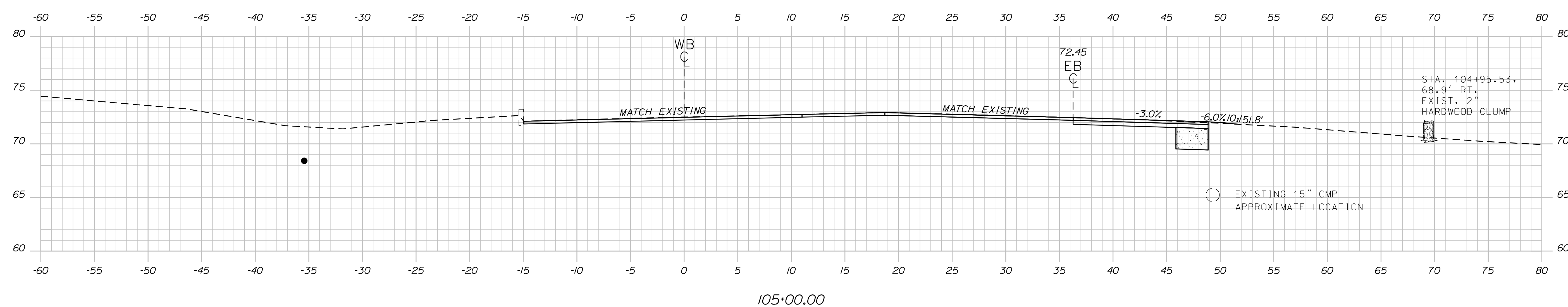
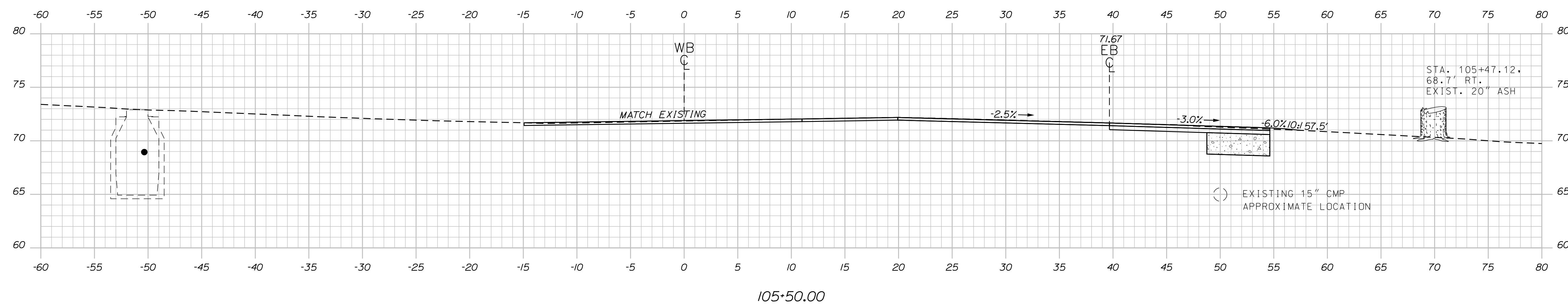
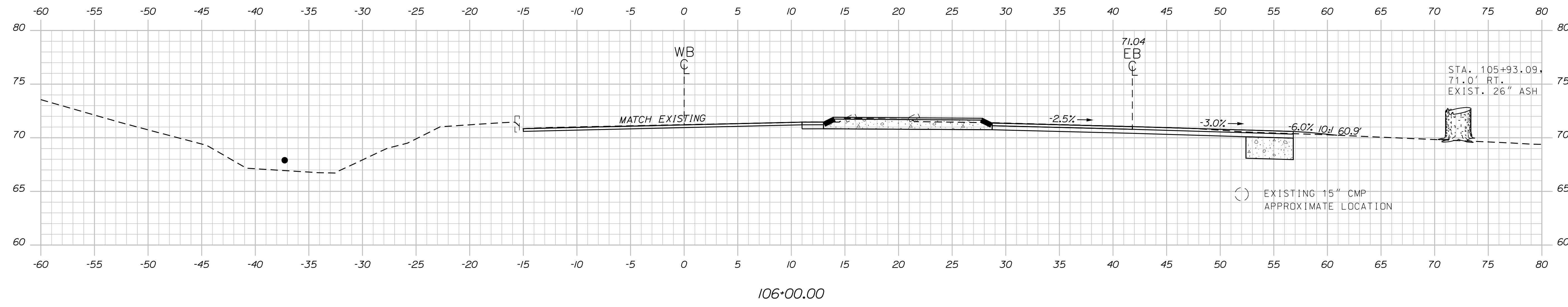

STATE OF MAINE  
DEPARTMENT OF TRANSPORTATION  
02379700  
WIN  
023797.00  
HIGHWAY PLANS

SHANE C. KELLY  
No. 15681  
PROFESSIONAL ENGINEER  
SIGNATURE  
15681  
P.E. NUMBER  
12/09/2021  
DATE

PROJ. MANAGER	E. MARTIN	BY	DATE
DESIGN DETAILED		S. KELLY	12/09/21
CHECKED/REVIEWED		B. LYON	12/09/21
DESIGN DETAILED			
DESIGN DETAILED			
REVISIONS 1			
REVISIONS 2			
REVISIONS 3			
REVISIONS 4			
FIELD CHANGES			

WESTBROOK  
WILLIAM CLARKE DRIVE  
CROSS SECTIONS

SHEET NUMBER  
32  
OF 46

Date: 12/19/2021

Username: skelly

Division: HIGHWAY

Filename: ... \MSTA\Sheet Sets\Xsect.dgn

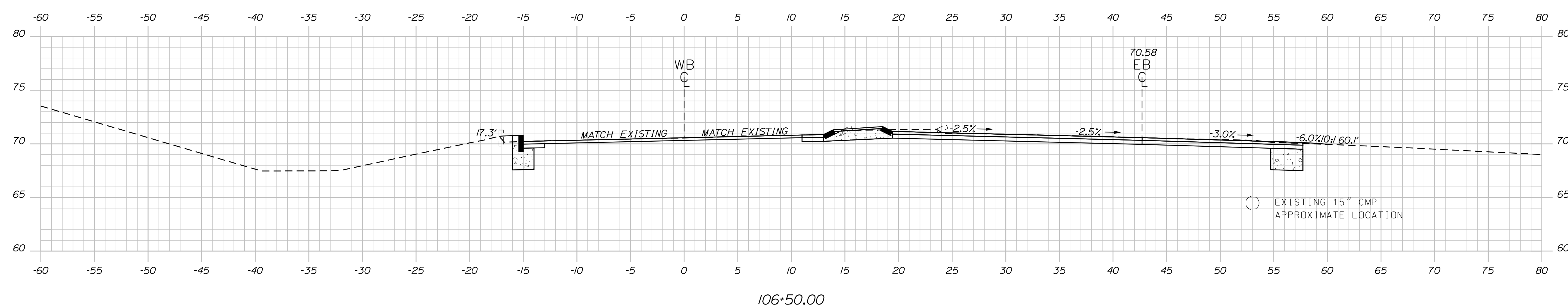
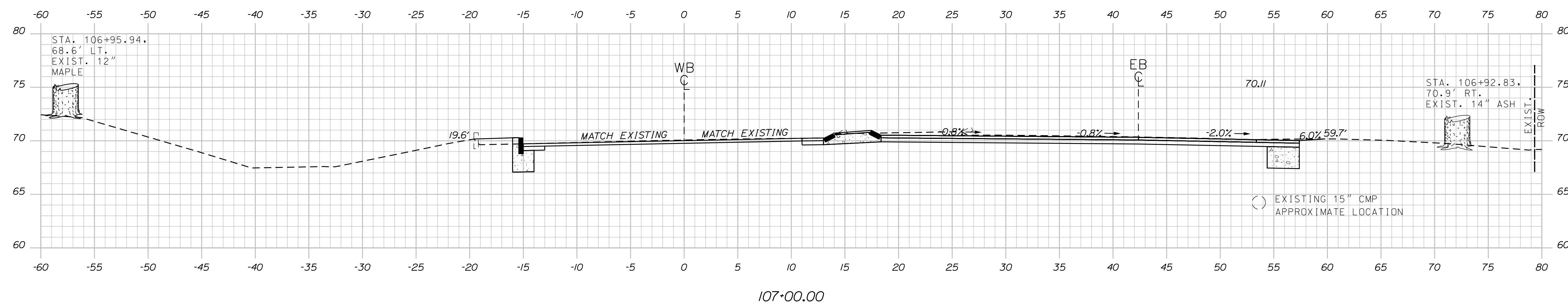
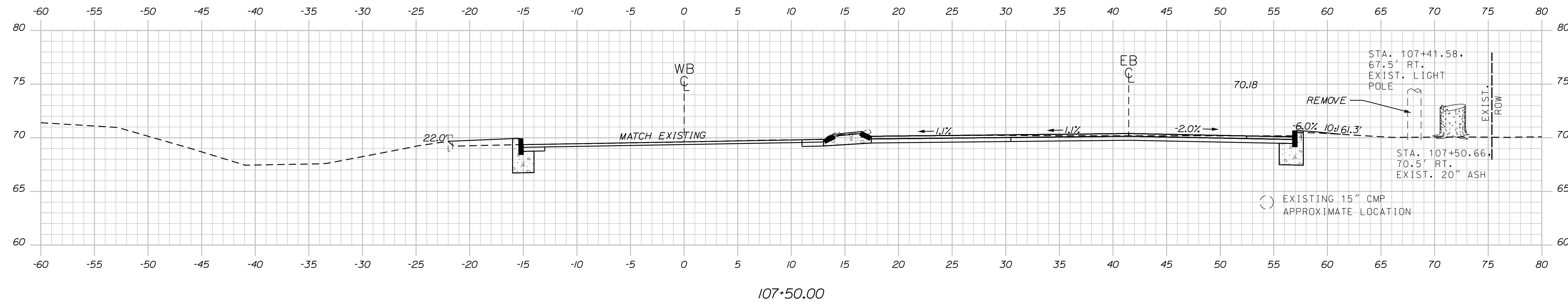

STATE OF MAINE  
DEPARTMENT OF TRANSPORTATION  
02379700  
WIN  
023797.00  
HIGHWAY PLANS

SHANE C. KELLY  
No. 15681  
PROFESSIONAL ENGINEER  
SIGNATURE  
15681  
P.E. NUMBER  
12/09/2021  
DATE

PROJ. MGR.	E. MARTIN	BY	DATE
DESIGN-DETAILED		S. KELLY	12/09/21
CHECKED-REVIEWED		B. LYON	12/09/21
DESIGN-DETAILED			
DESIGN-DETAILED			
REVISIONS 1			
REVISIONS 2			
REVISIONS 3			
REVISIONS 4			
FIELD CHANGES			

WESTBROOK  
WILLIAM CLARKE DRIVE  
CROSS SECTIONS

SHEET NUMBER  
**33**  
OF 46

Date: 12/19/2021

Username: skelly

Division: HIGHWAY

Filename: ... \MSTA\Sheet Sets\Xsect.dgn

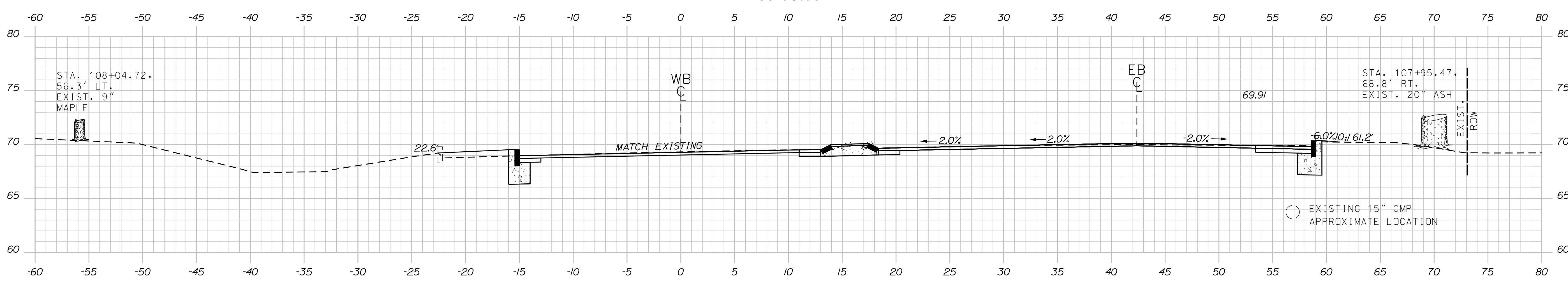
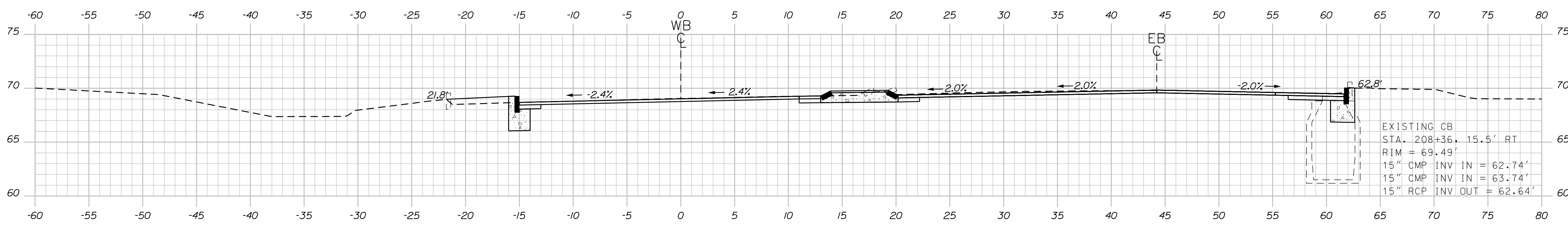
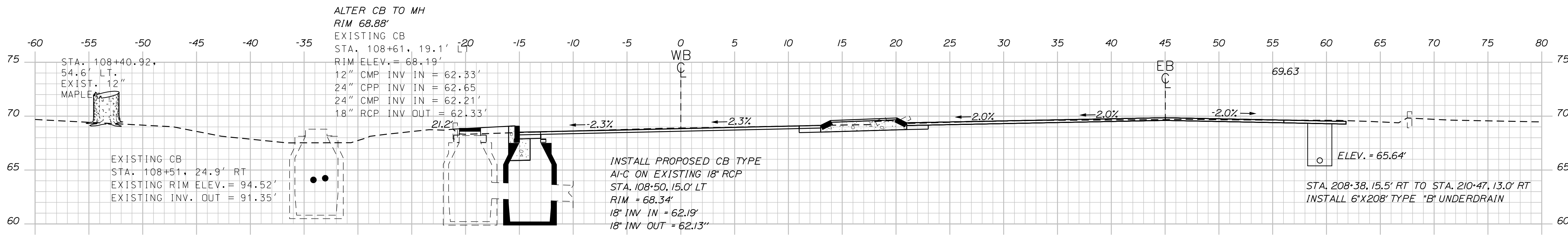
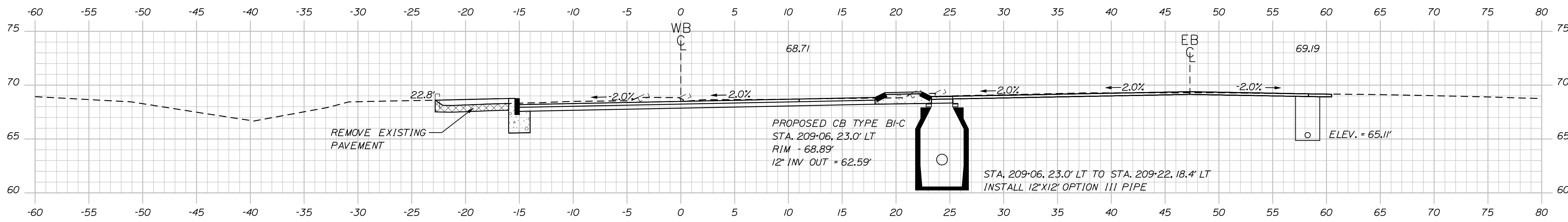

STATE OF MAINE  
 DEPARTMENT OF TRANSPORTATION  
 02379700  
 WIN  
 023797.00  
 HIGHWAY PLANS

SHANE C. KELLY  
 No. 15681  
 PROFESSIONAL ENGINEER  
 SIGNATURE  
 15681  
 P.E. NUMBER  
 12/09/2021  
 DATE

PROJ. MANAGER	DATE	BY	DATE
E. MARTIN	12/09/21	S. KELLY	12/09/21
CHECKED-REVIEWED		B. LYON	
DESIGN-REVIEWED			
DESIGN-DETAILED			
DESIGN-DETAILED			
REVISIONS 1			
REVISIONS 2			
REVISIONS 3			
REVISIONS 4			
FIELD CHANGES			

WESTBROOK  
 WILLIAM CLARKE DRIVE  
 CROSS SECTIONS

SHEET NUMBER  
 34  
 OF 46

Date: 12/19/2021

Username: skelly

Division: HIGHWAY

Filename: ... \MSTA\Sheet Sets\Xsect.dgn

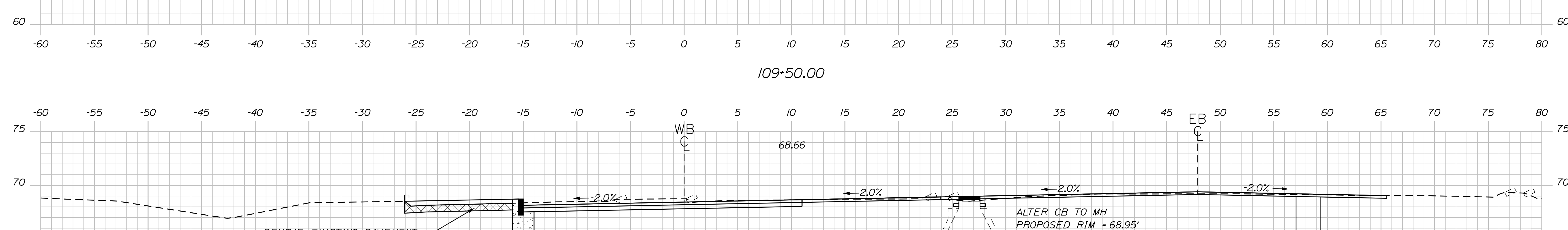
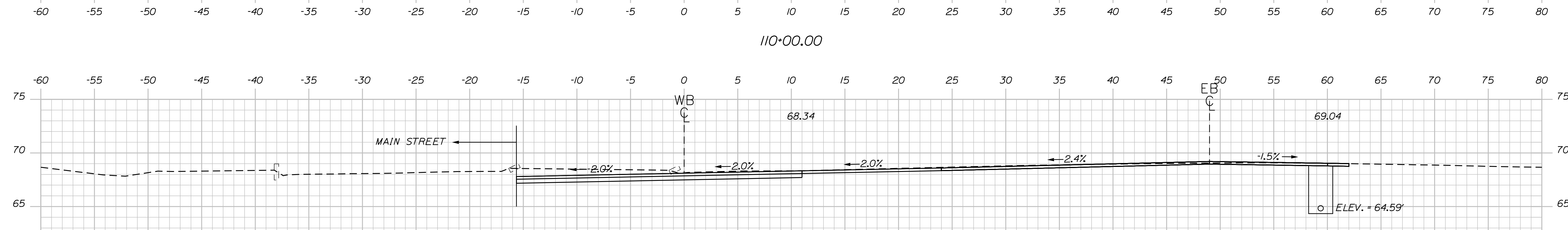
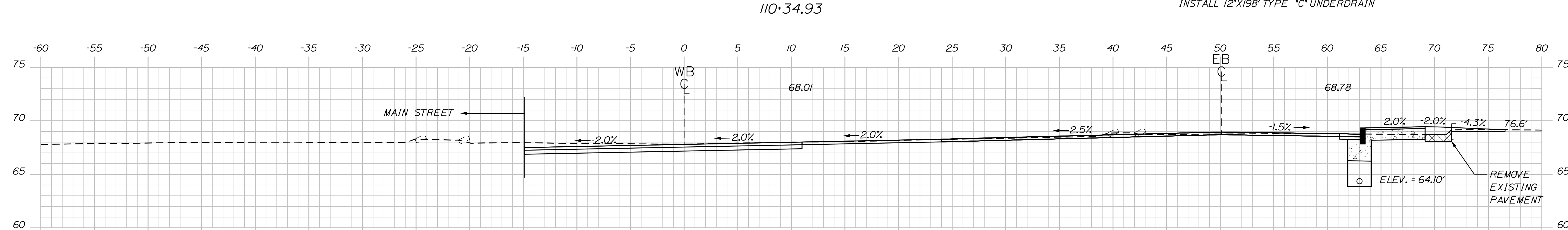
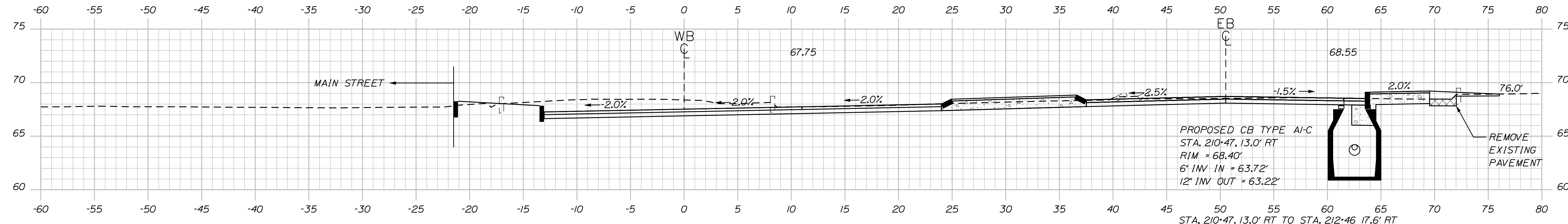

STATE OF MAINE  
DEPARTMENT OF TRANSPORTATION  
02379700  
WIN  
023797.00  
HIGHWAY PLANS

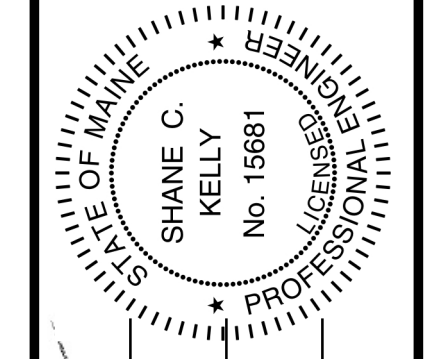

SIGNATURE: SHANE C. KELLY  
No. 15681  
P.E. NUMBER: 15681  
DATE: 12/09/2021

PROJ. MANAGER	BY	DATE
E. MARTIN	S. KELLY	12/09/21
CHECKED-REVIEWED	B. LYON	12/09/21
DESIGN DETAILED		
DESIGN DETAILED		
REVISIONS 1		
REVISIONS 2		
REVISIONS 3		
REVISIONS 4		
FIELD CHANGES		

WESTBROOK  
WILLIAM CLARKE DRIVE  
CROSS SECTIONS

SHEET NUMBER  
**35**  
OF 46

Date: 12/19/2021

Username: skelly

Division: HIGHWAY

Filename: ... \MSTA\Sheet Sets\Xsect.dgn

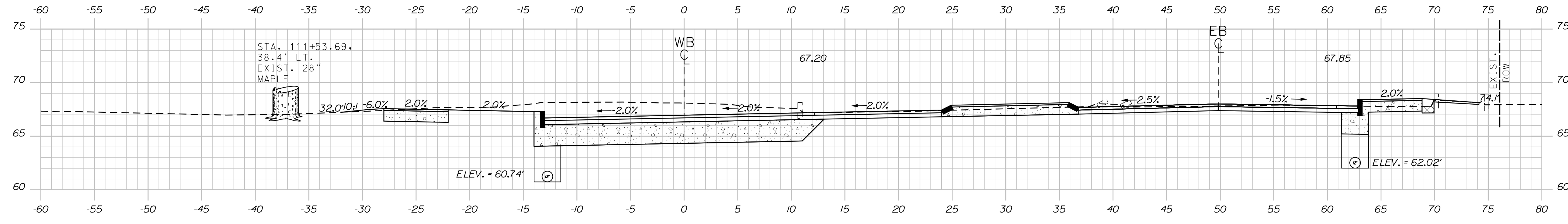

III+50.00

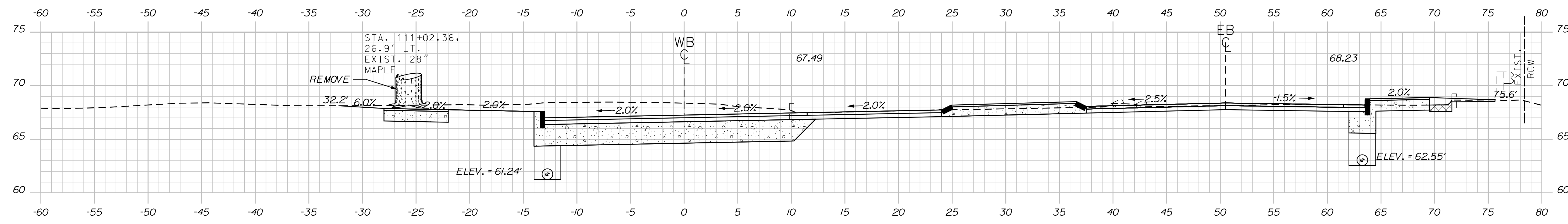

III+00.00

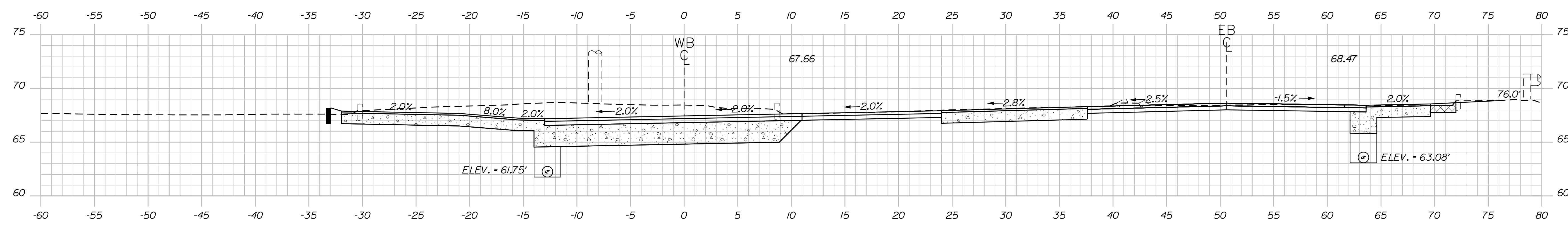

III+50.00 (CURB RAMP LT, MEDIAN, RT)

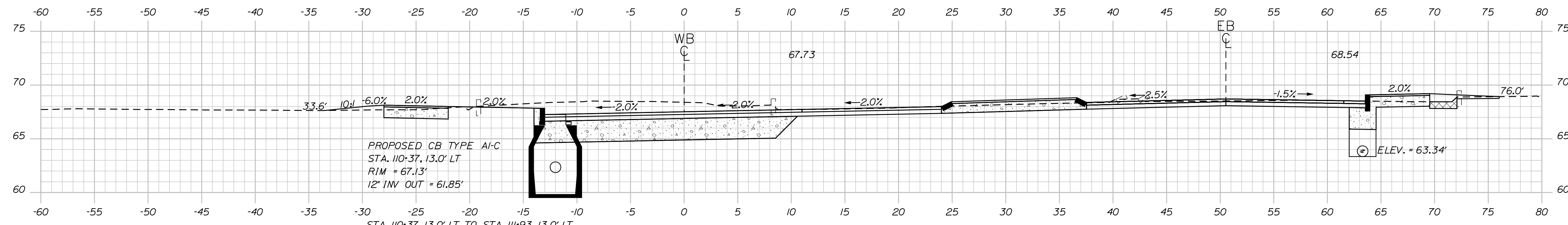

III+37.35

PROPOSED CB TYPE A1-C  
 STA. 110+37. 13.0' LT  
 RIM = 67.13'  
 12" INV OUT = 61.85'  
 STA. 110+37. 13.0' LT TO STA. 111+93. 13.0' LT  
 INSTALL 12"X150' TYPE "C" UNDERDRAIN

STATE OF MAINE  
 DEPARTMENT OF TRANSPORTATION  
 02379700  
 WIN  
 023797.00  
 HIGHWAY PLANS

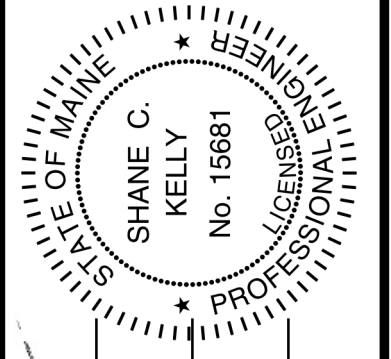

SIGNATURE  
 15681  
 P.E. NUMBER  
 12/09/2021  
 DATE

PROJ. MANAGER	DATE	BY	E-MARTIN
DESIGN-DETAILED	12/09/21	S. KELLY	
CHECKED-REVIEWED	12/09/21	B. LYON	
DESIGN-DETAILED			
DESIGN-DETAILED			
REVISIONS 1			
REVISIONS 2			
REVISIONS 3			
REVISIONS 4			
FIELD CHANGES			

WESTBROOK  
 WILLIAM CLARKE DRIVE  
 CROSS SECTIONS

SHEET NUMBER  
 36  
 OF 46

Sta. 110+37.35 to Sta. 111+50.00

Date: 12/19/2021

Username: skelly

Division: HIGHWAY

Filename: ... \MSTA\Sheet Sets\Xsect.dgn

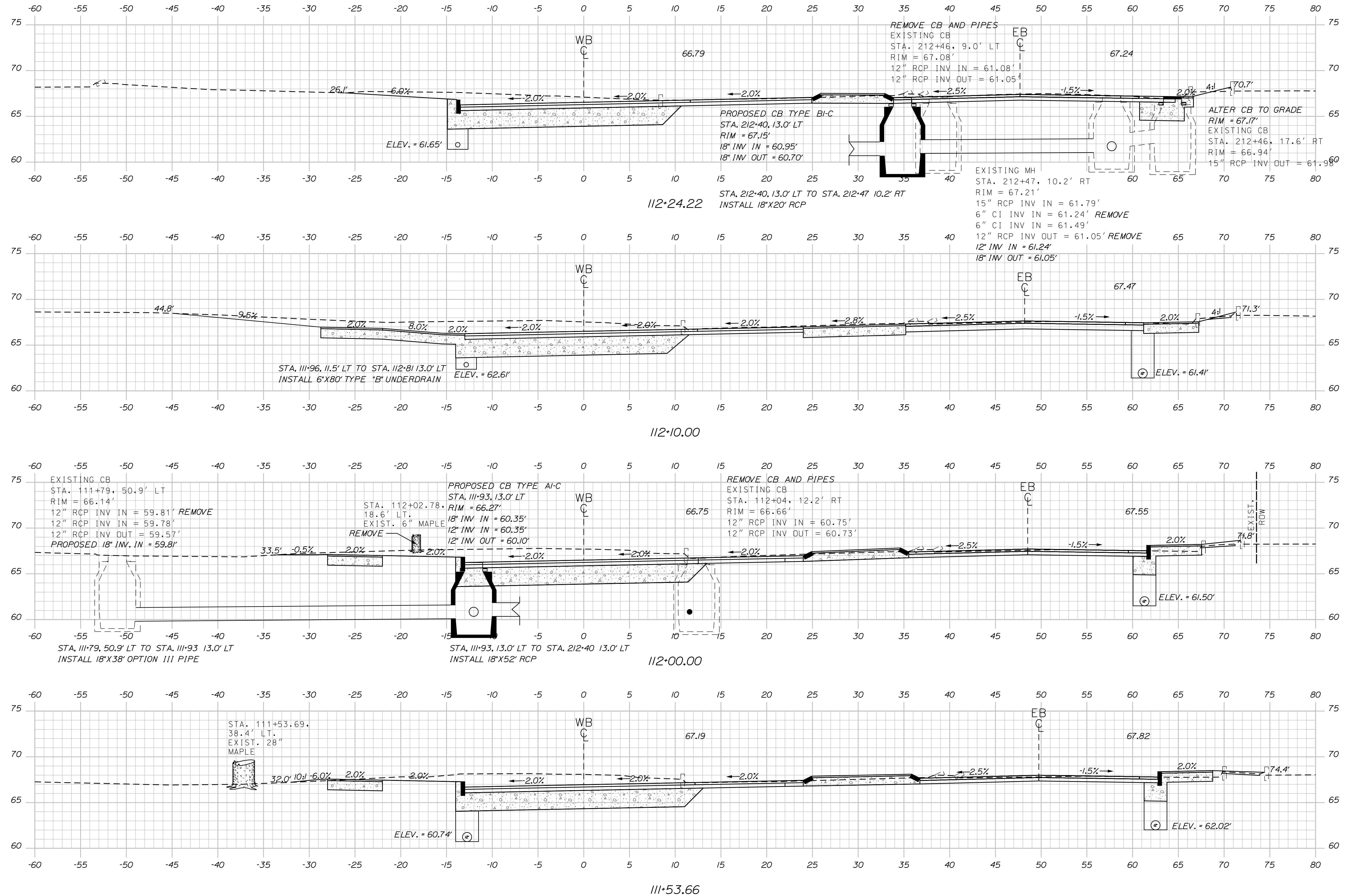

STATE OF MAINE  
DEPARTMENT OF TRANSPORTATION  
02379700  
WIN  
023797.00  
HIGHWAY PLANS

SHANE C. KELLY  
No. 15681  
PROFESSIONAL ENGINEER

SIGNATURE: [Signature]  
15681  
P.E. NUMBER  
12/09/2021  
DATE

PROJ. MANAGER	DATE	BY	E-MARTIN	DESIGN-DETAILED	CHECKED-REVIEWED	DESIGN-DETAILED	DESIGN-DETAILED	REVISIONS 1	REVISIONS 2	REVISIONS 3	REVISIONS 4	FIELD CHANGES
	12/09/21	S. KELLY										
	12/09/21	B. LYON										

WESTBROOK  
WILLIAM CLARKE DRIVE  
CROSS SECTIONS

SHEET NUMBER  
**37**  
OF 46

Date: 12/19/2021

Username: skelly

Division: HIGHWAY

Filename: ... \MSTA\Sheet Sets\Xsect.dgn

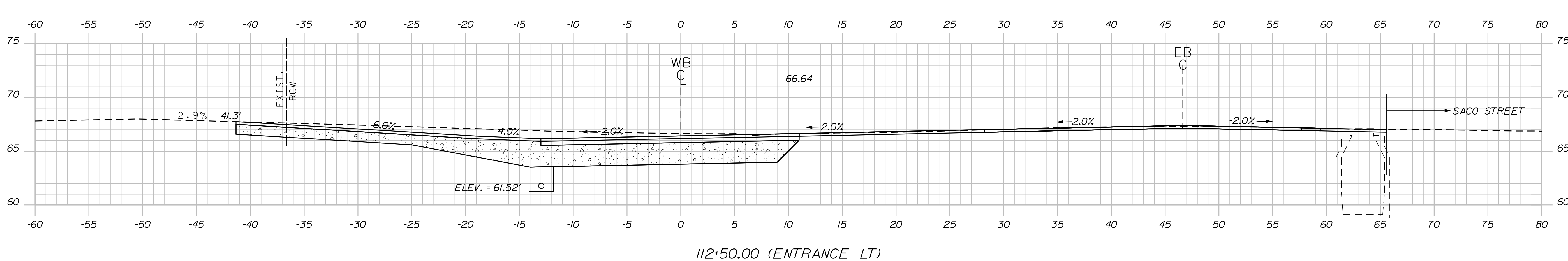
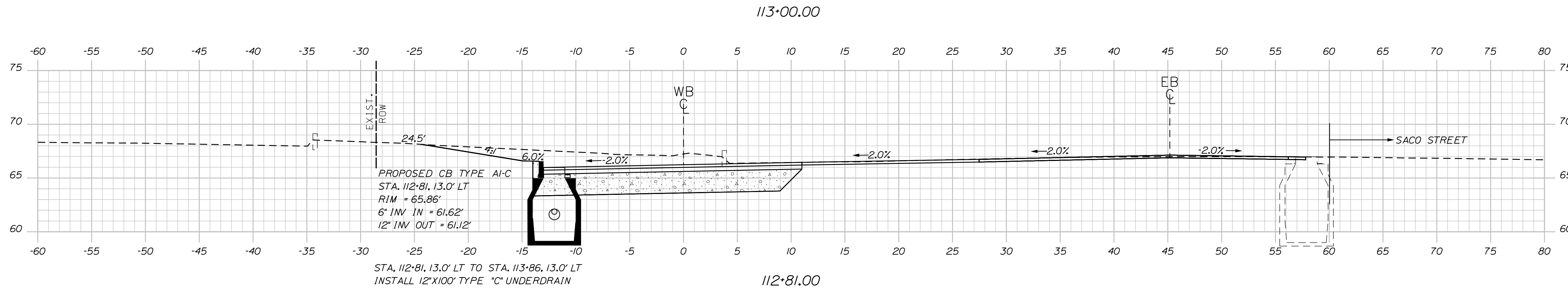
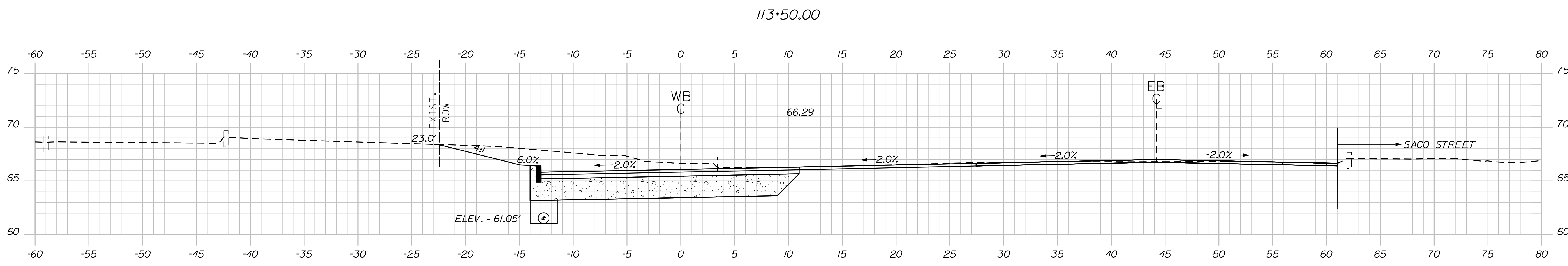
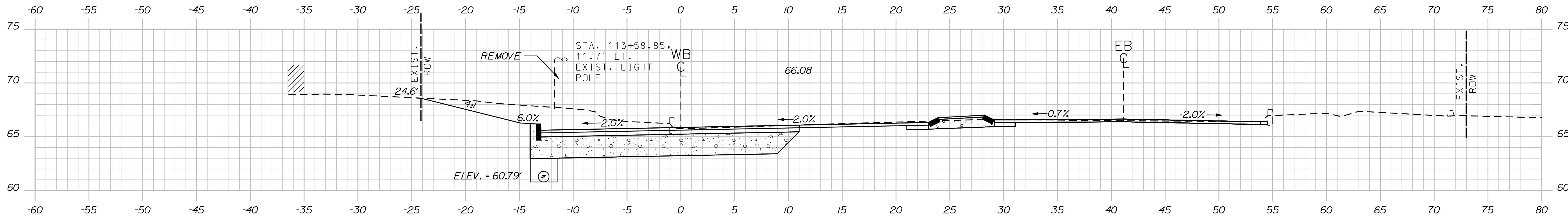

STATE OF MAINE  
DEPARTMENT OF TRANSPORTATION  
02379700  
WIN  
023797.00  
HIGHWAY PLANS

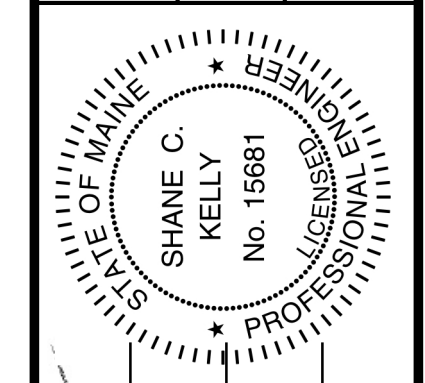

SIGNATURE: SHANE C. KELLY  
No. 15681  
P.E. NUMBER: 15681  
DATE: 12/09/2021

PROJ. MANAGER	DATE
E. MARTIN	12/09/21
DESIGN-DETAILED	12/09/21
CHECKED-REVIEWED	
DESIGN-DETAILED	
DESIGN-DETAILED	
REVISIONS 1	
REVISIONS 2	
REVISIONS 3	
REVISIONS 4	
FIELD CHANGES	

WESTBROOK  
WILLIAM CLARKE DRIVE  
CROSS SECTIONS

SHEET NUMBER  
**38**  
OF 46



Date: 12/19/2021

Username: skelly

Division: HIGHWAY

Filename: ... \MSTA\Sheet Sets\Xsect.dgn

END PROJECT STA. 116+01.89

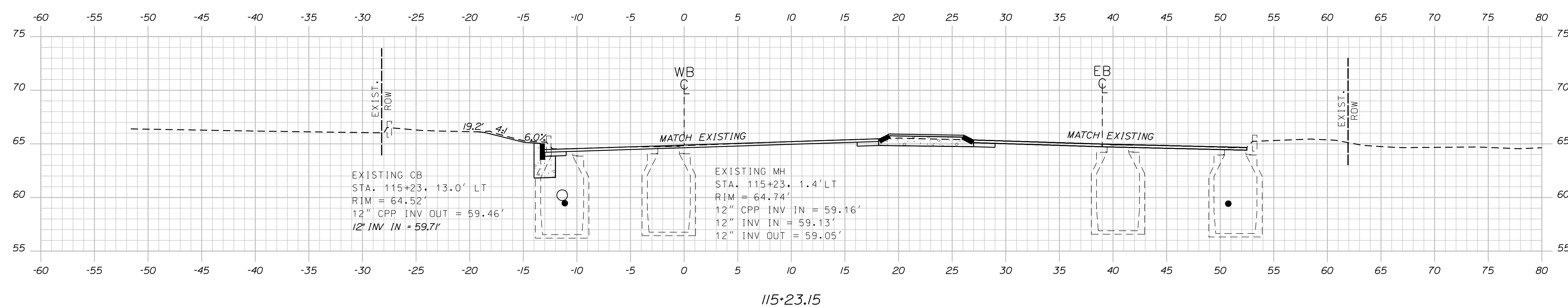
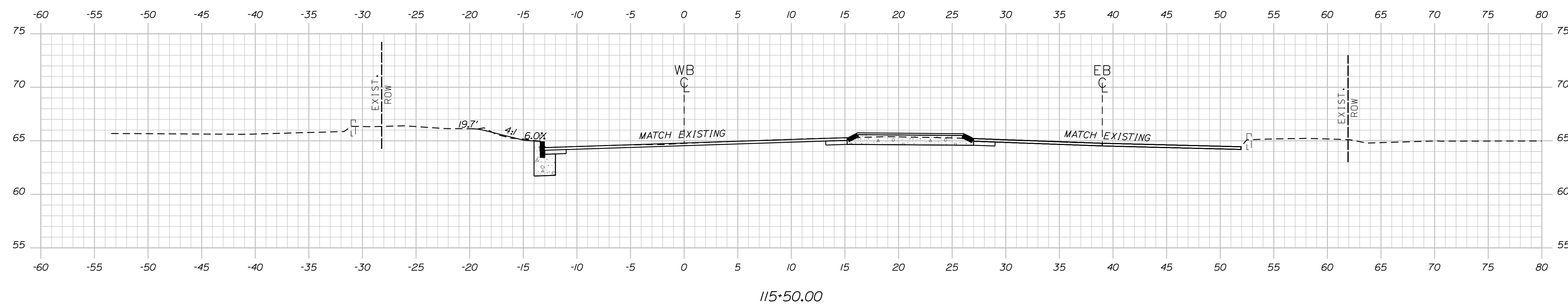
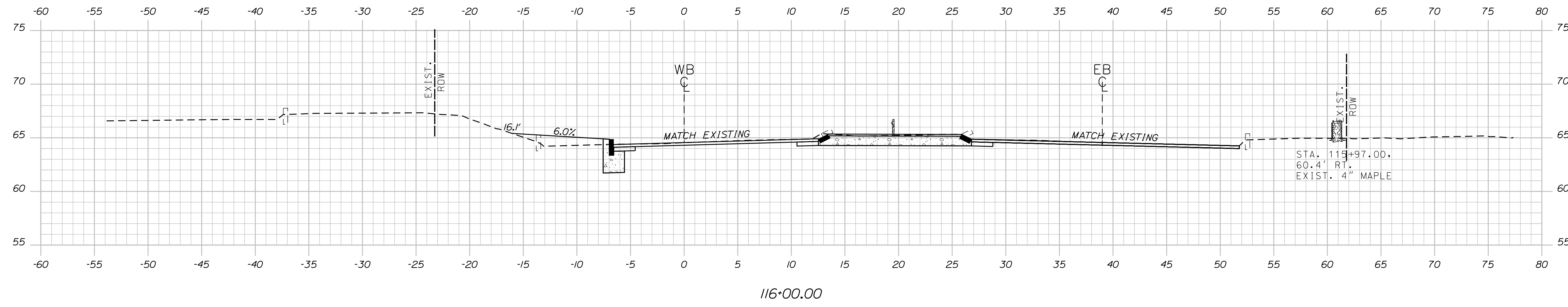

STATE OF MAINE  
 DEPARTMENT OF TRANSPORTATION  
 02379700  
 WIN  
 023797.00  
 HIGHWAY PLANS

SHANE C. KELLY  
 No. 15681  
 PROFESSIONAL ENGINEER  
 SIGNATURE  
 15681  
 P.E. NUMBER  
 12/09/2021  
 DATE

PROJ. MANAGER	E. MARTIN	BY	DATE
DESIGN DETAILED		S. KELLY	12/09/21
CHECKED/REVIEWED		B. LYON	12/09/21
DESIGNS DETAILED			
DESIGNS DETAILED			
REVISIONS 1			
REVISIONS 2			
REVISIONS 3			
REVISIONS 4			
FIELD CHANGES			

WESTBROOK  
 WILLIAM CLARKE DRIVE  
 CROSS SECTIONS

SHEET NUMBER  
 40  
 OF 46

Date: 12/19/2021

Username: skelly

Division: HIGHWAY

Filename: ... \MSTA\Sheet Sets\Xsect.dgn

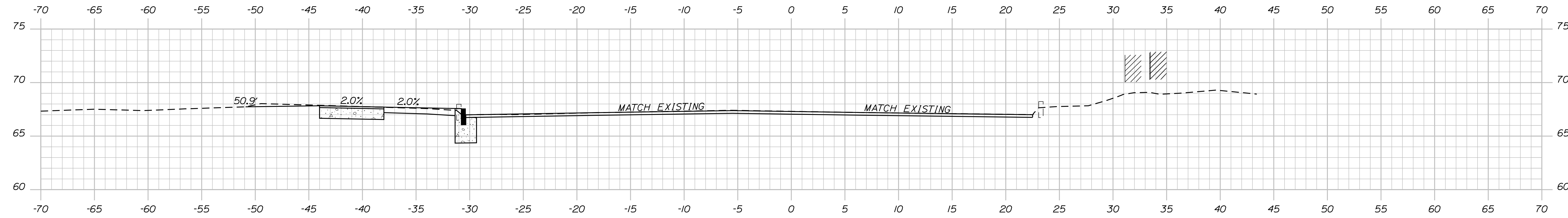

301+50.00

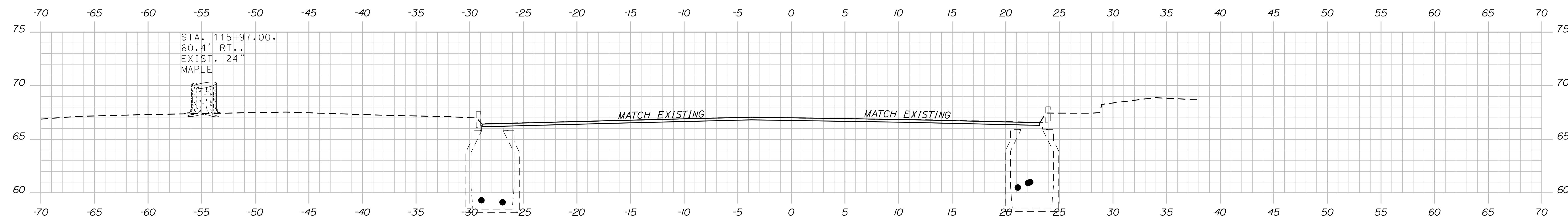

301+00.00

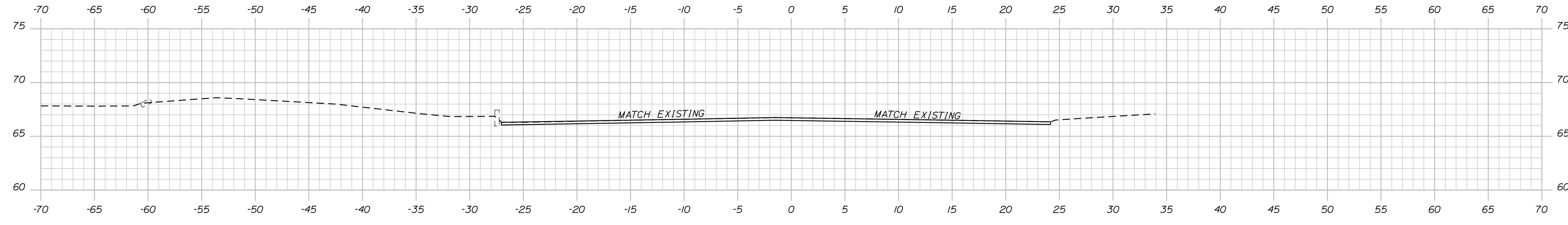

300+50.00

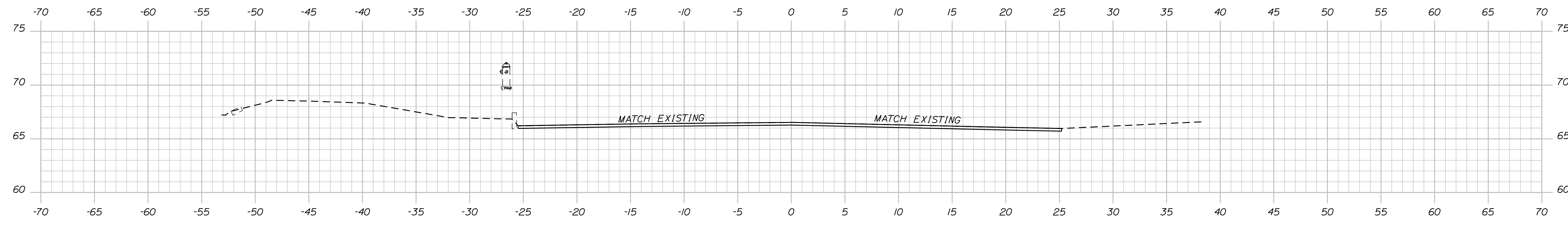

300+00.00

STATE OF MAINE  
DEPARTMENT OF TRANSPORTATION  
02379700  
WIN  
023797.00  
HIGHWAY PLANS

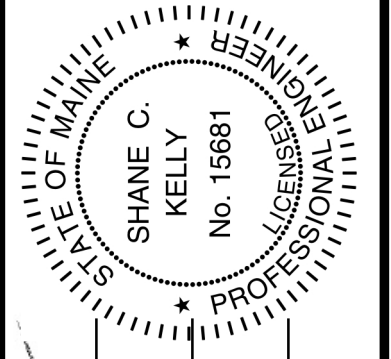

SIGNATURE  
P.E. NUMBER  
DATE

PROJ. MANAGER	BY	DATE
E. MARTIN	S. KELLY B. LYON	12/09/21 12/09/21
DESIGN DETAILED		
CHECKED-REVIEWED		
DESIGNS DETAILED		
DESIGNS DETAILED		
REVISIONS 1		
REVISIONS 2		
REVISIONS 3		
REVISIONS 4		
FIELD CHANGES		

WESTBROOK  
MAIN STREET  
CROSS SECTIONS

SHEET NUMBER  
**41**  
OF 46

Date: 12/19/2021

Username: skelly

Division: HIGHWAY

Filename: ... \MSTA\Sheet Sets\Xsect.dgn

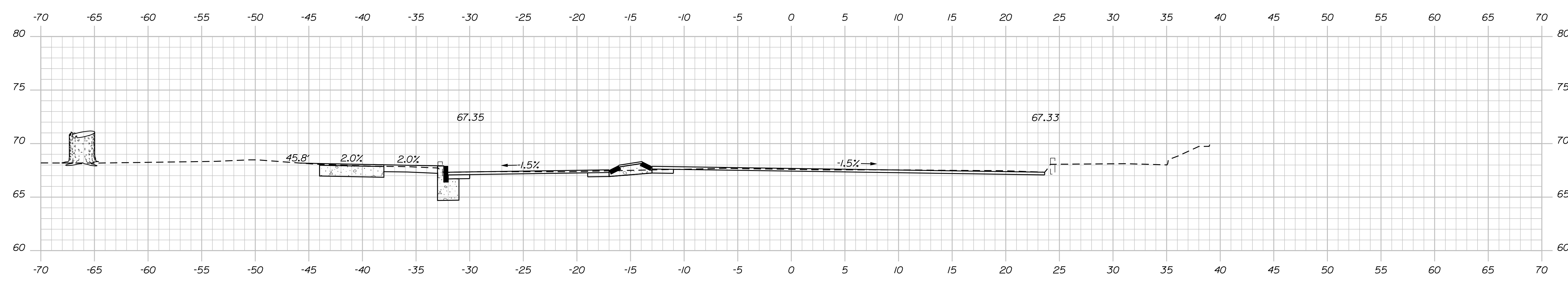
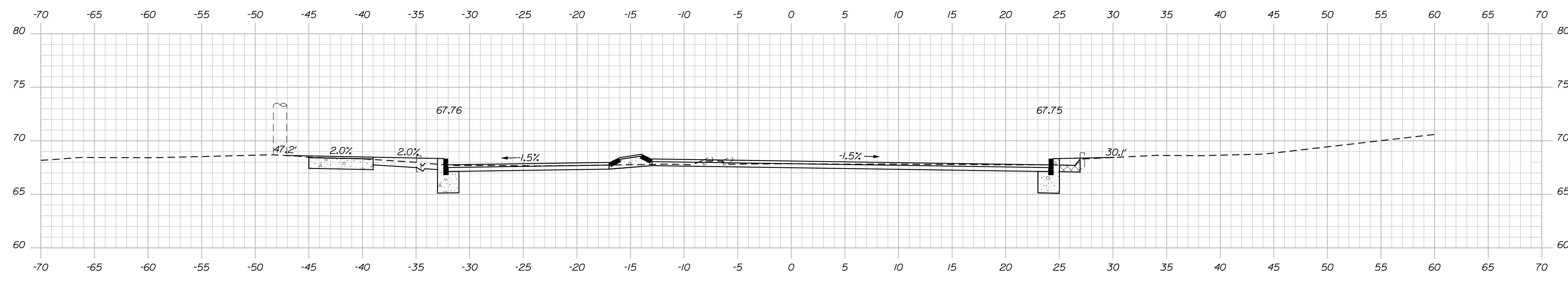

STATE OF MAINE  
DEPARTMENT OF TRANSPORTATION  
02379700  
WIN  
023797.00  
HIGHWAY PLANS

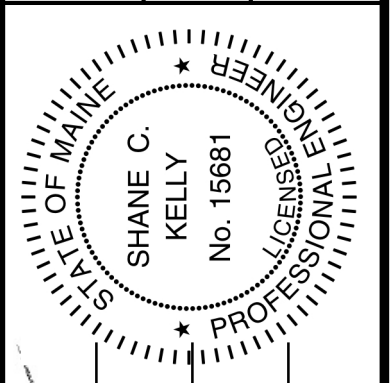

SIGNATURE  
15681  
P.E. NUMBER  
12/09/2021  
DATE

PROJ. MANAGER	E. MARTIN	DATE	12/09/21
DESIGN-DETAILED	S. KELLY	BY	S. KELLY
CHECKED-REVIEWED	B. LYON	DATE	12/09/21
DESIGN-DETAILED			
DESIGN-DETAILED			
REVISIONS 1			
REVISIONS 2			
REVISIONS 3			
REVISIONS 4			
FIELD CHANGES			

WESTBROOK  
MAIN STREET  
CROSS SECTIONS

SHEET NUMBER  
42  
OF 46

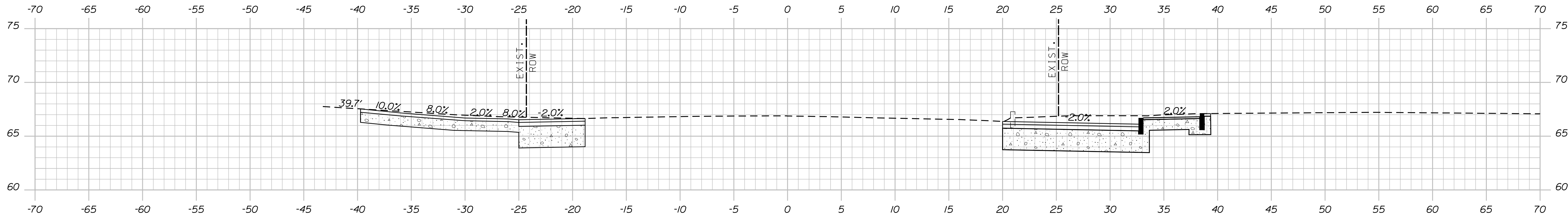

400+50.00 (ENTRANCE LT)

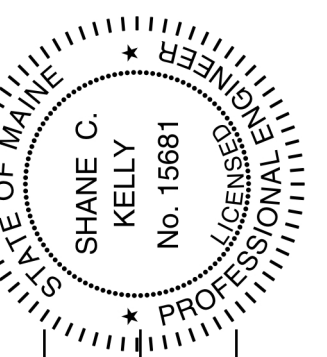

SIGNATURE  
 P.E. NUMBER  
 DATE

PROJ. MANAGER	DATE
DESIGN-DETAILED	12/09/21
CHECKED-REVIEWED	12/09/21
DESIGN-DETAILED	
DESIGN-DETAILED	
REVISIONS 1	
REVISIONS 2	
REVISIONS 3	
REVISIONS 4	
FIELD CHANGES	

WESTBROOK  
 SACO STREET  
 CROSS SECTIONS

SHEET NUMBER  
**43**  
 OF 46

STATE OF MAINE  
 DEPARTMENT OF TRANSPORTATION  
**02379700**  
 WIN  
 023797.00  
 HIGHWAY PLANS

Town, County, State	_____
Approx. Property Lines	P.L.
Existing Right of Way	_____
Limits of Wrought Portion	L.O.W.P.
Control Of Access	C.O.A.
New Right of Way	_____
New Easement	_____
New Temporary Rights	_____
New R/W Within Existing R/W	_____

New R/W Along Existing R/W	_____
Building	_____
Trees	Conifer _____ Deciduous _____
Water Edge	_____
Ledge	_____
Fence	CHAIN LINK _____ BARB WIRE _____ STOCKADE _____
Sign	_____
Clearing Limit Line	_____
Bush Line	_____
Rock/Boulder	_____
Flag Pole	_____
Well	_____
Mallbox	_____

PLAN LEGEND	
Existing	Proposed
Sanitary Sewer	_____
Telephone Line	_____
Electric Line	_____
Water Line	_____
Underdrain Line	_____
Gas Line	_____
Guardrail	_____
Culvert	_____
Travelled Way	_____
Ditch	_____
Catch Basin	_____
Manhole	_____
Sewer Manhole	_____
Utility Pole	_____
Fire Hydrant	_____
Curbing	_____

Cut Line	_____
Stonewall	_____
Baseline	10+00 _____ 11+00 _____ 12+00 _____
Monument	_____
Iron Rod Found	IRF
Replacement Pin Set	_____
Fill Line	_____
Retaining Wall	_____
Traverse Point	_____
Pipe Found	IPF

THIS PLAN WAS PREPARED IN CONNECTION WITH THE DEPARTMENT'S ACQUISITION OF REAL PROPERTY FOR TRANSPORTATION PURPOSES. IT CANNOT BE USED TO ESTABLISH LEGAL BOUNDARIES BETWEEN ABUTTING PROPERTY OWNERS.

STATE OF MAINE  
REGISTRY OF DEEDS

COUNTY \_\_\_\_\_  
RECEIVED \_\_\_\_\_,  
at \_\_\_\_\_ h \_\_\_\_\_ m \_\_\_\_\_ M and  
recorded in Plan Bk \_\_\_\_\_, Pg. \_\_\_\_\_  
Attest: \_\_\_\_\_ REGISTER

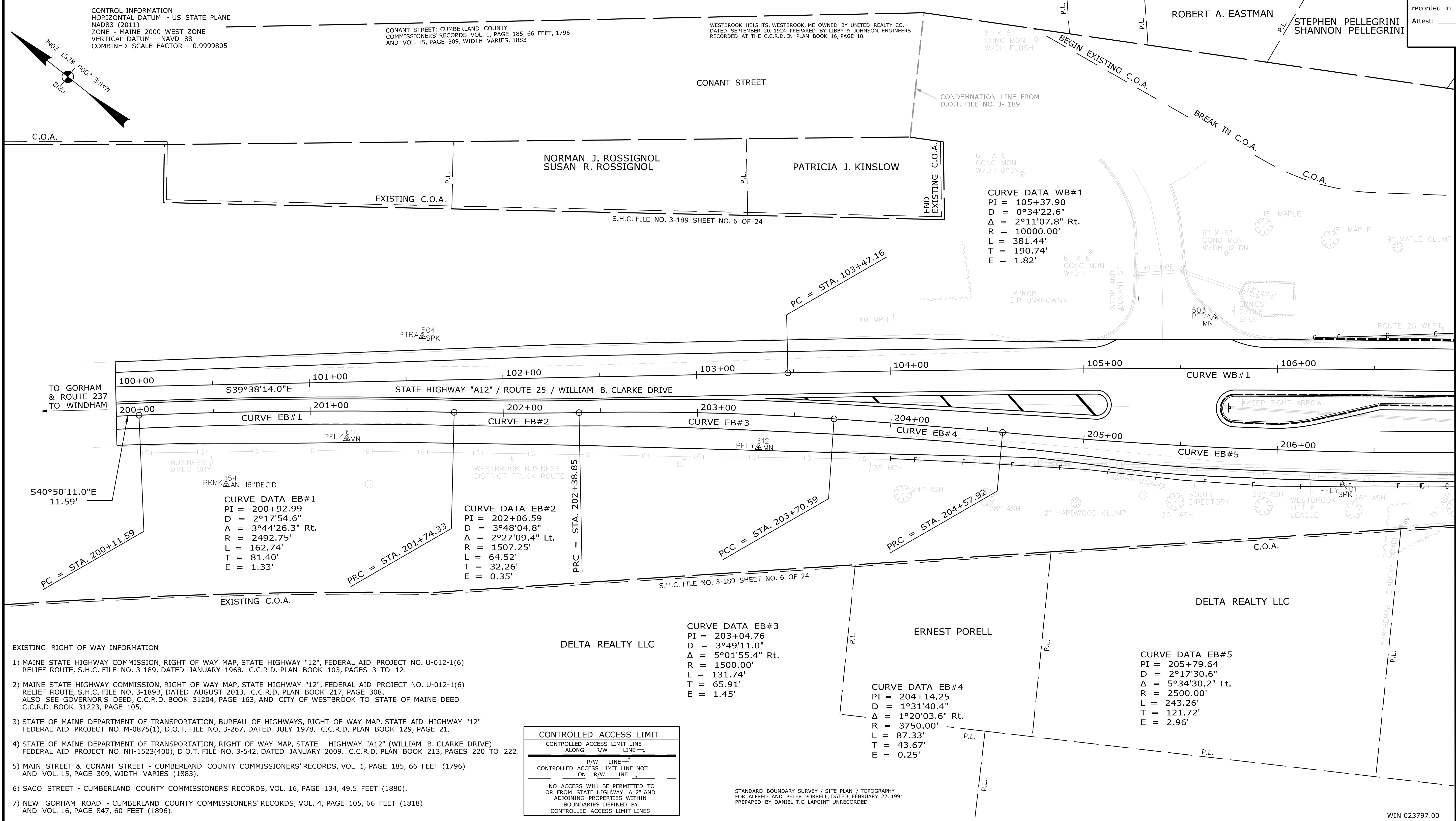

- EXISTING RIGHT OF WAY INFORMATION**
- 1) MAINE STATE HIGHWAY COMMISSION, RIGHT OF WAY MAP, STATE HIGHWAY "12", FEDERAL AID PROJECT NO. U-012-1(6) RELIEF ROUTE, S.H.C. FILE NO. 3-189, DATED JANUARY 1968. C.C.R.D. PLAN BOOK 103, PAGES 3 TO 12.
  - 2) MAINE STATE HIGHWAY COMMISSION, RIGHT OF WAY MAP, STATE HIGHWAY "12", FEDERAL AID PROJECT NO. U-012-1(6) RELIEF ROUTE, S.H.C. FILE NO. 3-189B, DATED AUGUST 2013. C.C.R.D. PLAN BOOK 217, PAGE 308. ALSO SEE GOVERNOR'S DEED, C.C.R.D. BOOK 31204, PAGE 163, AND CITY OF WESTBROOK TO STATE OF MAINE DEED C.C.R.D. BOOK 31223, PAGE 105.
  - 3) STATE OF MAINE DEPARTMENT OF TRANSPORTATION, BUREAU OF HIGHWAYS, RIGHT OF WAY MAP, STATE AID HIGHWAY "12" FEDERAL AID PROJECT NO. M-0875(1), D.O.T. FILE NO. 3-267, DATED JULY 1978. C.C.R.D. PLAN BOOK 129, PAGE 21.
  - 4) STATE OF MAINE DEPARTMENT OF TRANSPORTATION, RIGHT OF WAY MAP, STATE HIGHWAY "A12" (WILLIAM B. CLARKE DRIVE) FEDERAL AID PROJECT NO. NH-1523(400), D.O.T. FILE NO. 3-542, DATED JANUARY 2009. C.C.R.D. PLAN BOOK 213, PAGES 220 TO 222.
  - 5) MAIN STREET & CONANT STREET - CUMBERLAND COUNTY COMMISSIONERS' RECORDS, VOL. 1, PAGE 185, 66 FEET (1796) AND VOL. 15, PAGE 309, WIDTH VARIES (1883).
  - 6) SACO STREET - CUMBERLAND COUNTY COMMISSIONERS' RECORDS, VOL. 16, PAGE 134, 49.5 FEET (1880).
  - 7) NEW GORHAM ROAD - CUMBERLAND COUNTY COMMISSIONERS' RECORDS, VOL. 4, PAGE 105, 66 FEET (1818) AND VOL. 16, PAGE 847, 60 FEET (1896).

**CONTROLLED ACCESS LIMIT**

CONTROLLED ACCESS LIMIT LINE ALONG R/W LINE

R/W LINE

CONTROLLED ACCESS LIMIT LINE NOT ON R/W LINE

NO ACCESS WILL BE PERMITTED TO OR FROM STATE HIGHWAY "A12" AND ADJOINING PROPERTIES WITHIN BOUNDARIES DEFINED BY CONTROLLED ACCESS LIMIT LINES

STANDARD BOUNDARY SURVEY / SITE PLAN / TOPOGRAPHY FOR ALFRED AND PETER PORELL, DATED FEBRUARY 22, 1991 PREPARED BY DANIEL T.C. LAPONT UNRECORDED

Date: 12/18/2021  
Username: Jude.Hogan  
Division: ROW

ITEM	TECH	CHECKED
EXISTING CONDITION PLAN	R.M.C.	C.W.K.
FINAL RIGHT OF WAY	J.H.	G.L.L.
AREAS	J.H.	B.D.M.

STATE OF MAINE  
DEPARTMENT OF TRANSPORTATION  
16 STATE HOUSE STATION - AUGUSTA, ME 04333-0016 - 207-624-3460  
WESTBROOK  
RIGHT OF WAY MAP

REVISIONS			PLAN FILED IN PLAN BOOK			PAGE			COUNTY RECORD		
NO.	DATE	DESCRIPTION	NO.	GRANTOR	INSTRUMENT	DATE	BOOK	PAGE			

BRUCE A. VAN NOTE  
COMMISSIONER  
JOYCE NOEL TAYLOR  
CHIEF ENGINEER

DATE \_\_\_\_\_

STATE HIGHWAY "A12"  
ROUTE 25 / WILLIAM B. CLARKE DRIVE  
WESTBROOK CUMBERLAND COUNTY  
FEDERAL AID PROJECT NO. 2379700

OCTOBER 2021  
SCALE 1" = 25'

RIGHT-OF-WAY MAP  
SHEET 1 OF 3

D.O.T. FILE NO. 3-660

SHEET NUMBER  
**44**  
OF 46

PLAN LEGEND	
Town, County, State Approx. Property Lines Existing Right of Way Limits of Wrought Portion Control Of Access New Right of Way New Easement New Temporary Rights New R/W Within Existing R/W	New R/W Along Existing R/W Building Trees Water Edge Ledge Fence Sign Clearing Limit Line Conifer Deciduous Bush Line Rock/Boulder Flag Pole CHAIN LINK BARB WIRE WELL STOCKADE MALLBOX
Sanitary Sewer Telephone Line Electric Line Water Line Underdrain Line Gas Line Guardrail Culvert	Existing Proposed Traveled Way Ditch Catch Basin Manhole Sewer Manhole Utility Pole Fire Hydrant Curbing
Cut Line Stonewall Baseline Monument Iron Rod Found Replacement Pin Set	Existing Proposed Fill Line Retaining Wall Traverse Point Pipe Found

THIS PLAN WAS PREPARED IN CONNECTION WITH THE DEPARTMENT'S ACQUISITION OF REAL PROPERTY FOR TRANSPORTATION PURPOSES. IT CANNOT BE USED TO ESTABLISH LEGAL BOUNDARIES BETWEEN ADJUTING PROPERTY OWNERS.

Scale of Feet: 0, 25, 50, 75, 100

CONTROL INFORMATION  
 HORIZONTAL DATUM - US STATE PLANE NAD83 (2011)  
 ZONE - MAINE 2000 WEST ZONE  
 VERTICAL DATUM - NAVD 88  
 COMBINED SCALE FACTOR - 0.9999805

STATE OF MAINE  
 REGISTRY OF DEEDS

COUNTY \_\_\_\_\_  
 RECEIVED \_\_\_\_\_,  
 at \_\_\_\_\_ h \_\_\_\_\_ m \_\_\_\_\_ M and  
 recorded in Plan Bk \_\_\_\_\_, Pg. \_\_\_\_\_  
 Attest: \_\_\_\_\_ REGISTER

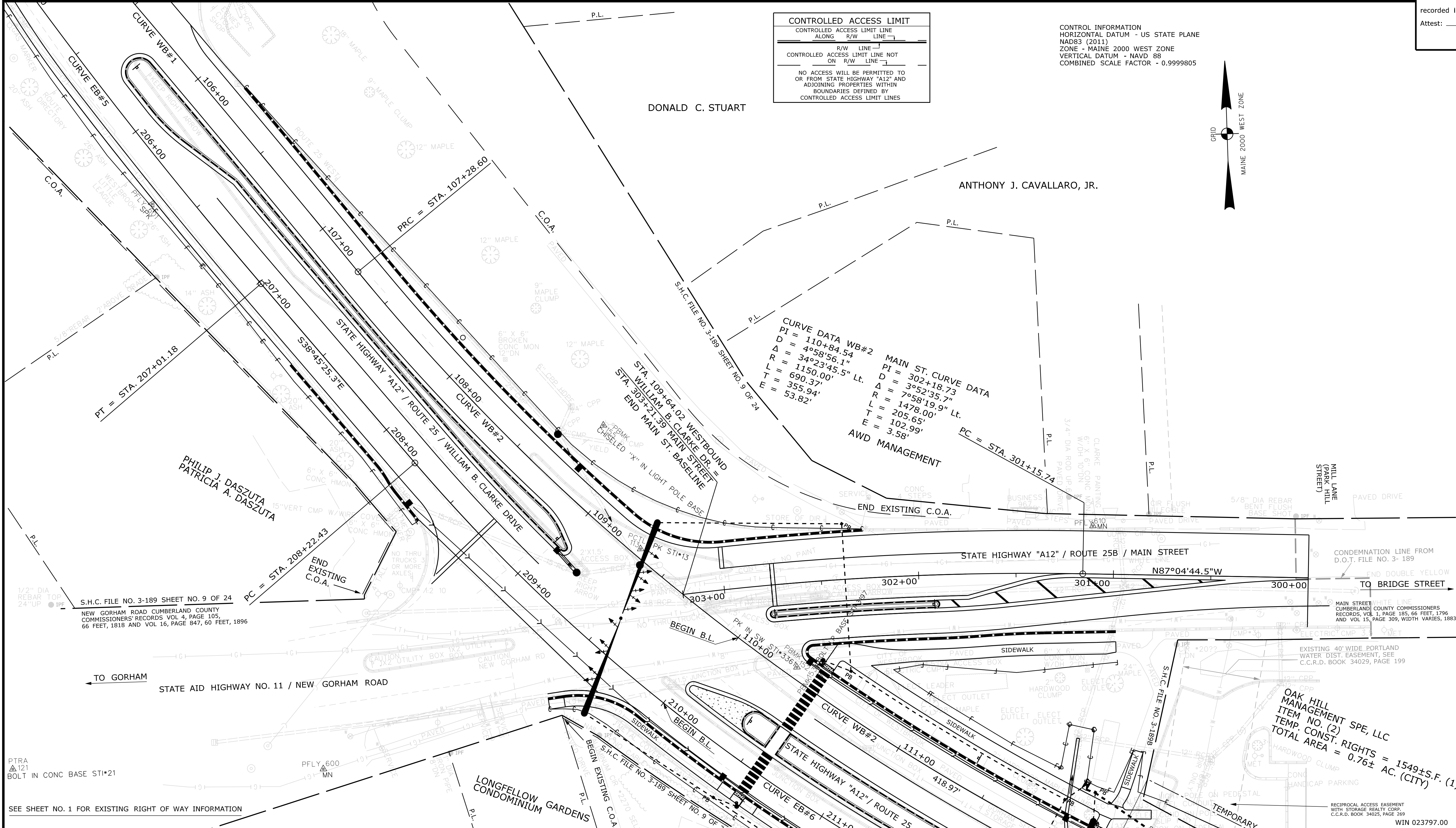

Date: 12/18/2021

Username: Jude.Hogan

Division: ROW

Filename: ... \00\ROW\MSTA045\_RWPLAN2.dgn

ITEM	TECH	CHECKED
EXISTING CONDITION PLAN	R.M.C.	C.W.K.
FINAL RIGHT OF WAY AREAS	J.H.	J.H.
		G.L.L.
		B.D.M.

STATE OF MAINE  
 DEPARTMENT OF TRANSPORTATION  
 16 STATE HOUSE STATION - AUGUSTA, ME 04333-0016 - 207-624-3460  
 WESTBROOK  
 RIGHT OF WAY MAP

REVISIONS			PLAN FILED IN PLAN BOOK				PAGE COUNTY RECORD			
NO.	DATE	DESCRIPTION	BY	NO.	GRANTOR	PAGE	INSTRUMENT	DATE	BOOK	PAGE

BRUCE A. VAN NOTE  
 COMMISSIONER  
 JOYCE NOEL TAYLOR  
 CHIEF ENGINEER

DATE

STATE HIGHWAY "A12"  
 ROUTE 25 / WILLIAM B. CLARKE DRIVE  
 WESTBROOK CUMBERLAND COUNTY  
 FEDERAL AID PROJECT NO. 2379700

OCTOBER 2021  
 SCALE 1" = 25'

RIGHT-OF-WAY MAP  
 SHEET 2 OF 3

D.O.T. FILE NO. 3-660

SHEET NUMBER  
**45**  
 OF 46

PLAN LEGEND	
<p>Sanitary Sewer</p> <p>Telephone Line</p> <p>Electric Line</p> <p>Water Line</p> <p>Underdrain Line</p> <p>Gas Line</p> <p>Guardrail</p> <p>Culvert</p>	<p>Existing</p> <p>Proposed</p>
<p>Traveled Way</p> <p>Ditch</p> <p>Catch Basin</p> <p>Manhole</p> <p>Sewer Manhole</p> <p>Utility Pole</p> <p>Fire Hydrant</p> <p>Curbing</p>	<p>Existing</p> <p>Proposed</p>
<p>Cut Line</p> <p>Stonewall</p> <p>Baseline</p> <p>Monument</p> <p>Iron Rod Found</p> <p>Replacement Pin Set</p>	<p>Fill Line</p> <p>Retaining Wall</p> <p>10+00</p> <p>11+00</p> <p>12+00</p> <p>Traverse Point</p> <p>Pipe Found</p>

THIS PLAN WAS PREPARED IN CONNECTION WITH THE DEPARTMENT'S ACQUISITION OF REAL PROPERTY FOR TRANSPORTATION PURPOSES. IT CANNOT BE USED TO ESTABLISH LEGAL BOUNDARIES BETWEEN ABUTTING PROPERTY OWNERS.

Scale of Feet

STATE OF MAINE  
REGISTRY OF DEEDS

COUNTY \_\_\_\_\_  
RECEIVED \_\_\_\_\_  
at \_\_\_\_\_ h \_\_\_\_\_ m \_\_\_\_\_ M and  
recorded in Plan Bk \_\_\_\_\_, Pg. \_\_\_\_\_  
Attest: \_\_\_\_\_ REGISTER

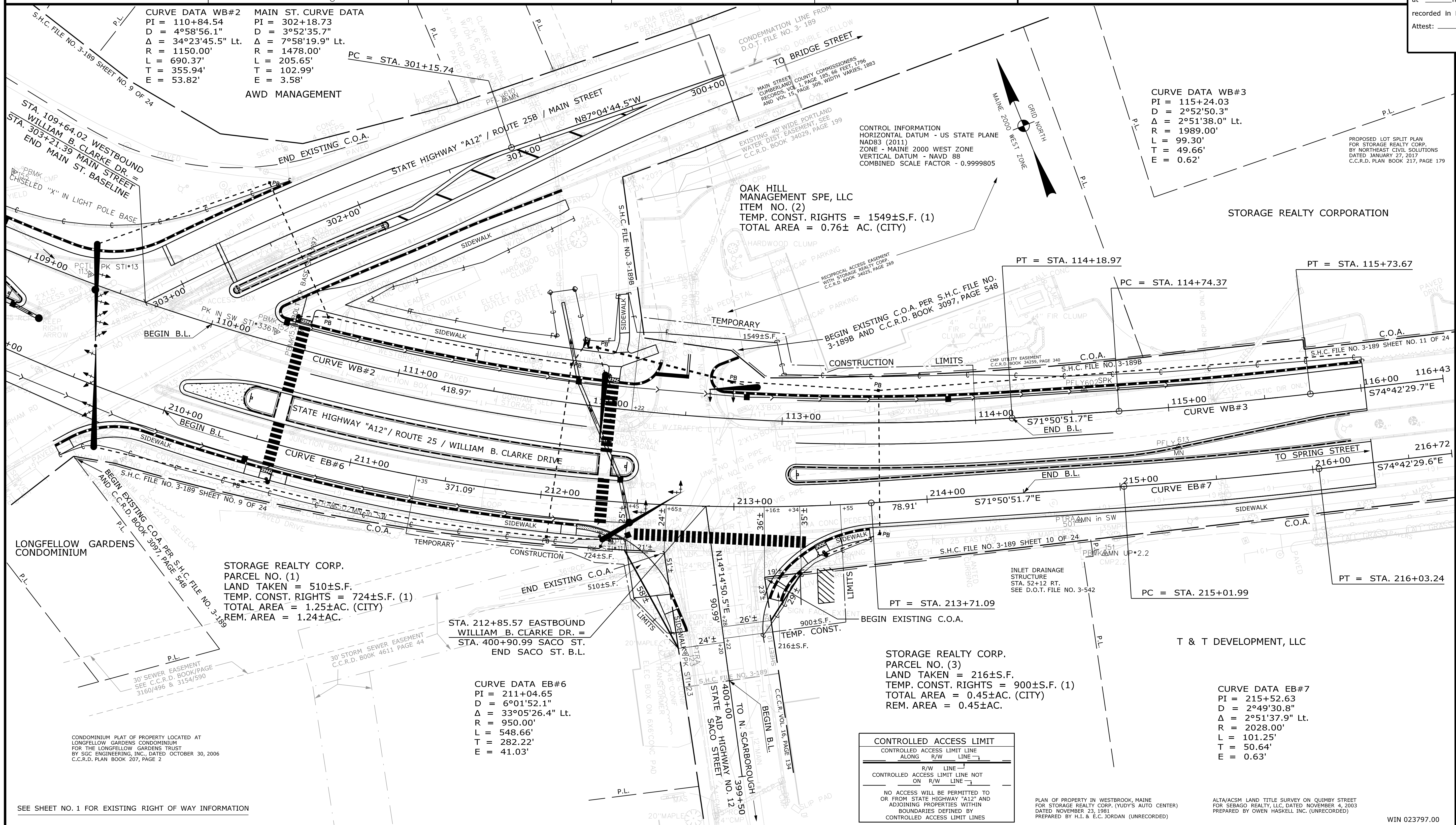

Date: 12/18/2021  
Username: Jude.Hogan  
Division: ROW  
Filename: ... \00\ROW\WSTA046\_RWPLAN3.dgn

ITEM	TECH	CHECKED			
		R.M.C.	C.W.K.	G.L.L.	B.D.M.
EXISTING CONDITION PLAN					
FINAL RIGHT OF WAY					
AREAS					

STATE OF MAINE  
DEPARTMENT OF TRANSPORTATION  
16 STATE HOUSE STATION - AUGUSTA, ME 04333-0016 - 207-624-3460  
WESTBROOK  
RIGHT OF WAY MAP

REVISIONS			PLAN FILED IN PLAN BOOK				PAGE COUNTY RECORD			
NO.	DATE	DESCRIPTION	BY	NO.	GRANTOR	PAGE	INSTRUMENT	DATE	BOOK	PAGE

BRUCE A. VAN NOTE  
COMMISSIONER  
JOYCE NOEL TAYLOR  
CHIEF ENGINEER

DATE \_\_\_\_\_

STATE HIGHWAY "A12"  
ROUTE 25 / WILLIAM B. CLARKE DRIVE  
WESTBROOK CUMBERLAND COUNTY  
FEDERAL AID PROJECT NO. 2379700

OCTOBER 2021  
SCALE 1" = 25'

RIGHT-OF-WAY MAP  
SHEET 3 OF 3

D.O.T. FILE NO. 3-660

WIN 023797.00

SHEET NUMBER  
**46**  
OF 46