

ESTIMATED QUANTITIES			
ITEM	DESCRIPTION	UNIT	QUANTITY
203.20	Common Excavation	CY	1600
304.10	Aggregate Subbase Course - Gravel (Type D)	CY	1150
403.208	Hot Mix Asphalt 12.5 mm	T	150
403.209	Hot Mix Asphalt 9.5 mm (Incidentals)	T	80
403.213	Hot Mix Asphalt 12.5 mm (Base and Intermediate)	T	220
409.15	Bituminous Tack Coat, Applied	G	70
603.159	12" Culvert Pipe Option III	LF	10
604.072	Catch Basin Type A1-C	EA	1
604.16	Altering Catch Basin to Manhole	EA	1
604.18	Altering Manhole or CB to Grade	EA	11
608.08	Reinforced Concrete Sidewalk	SY	150
608.26	Curb Ramp Detectible Warning Field	SF	270
608.45	Construct Sidewalk	SY	240
608.46	Regrading Sidewalk	SY	170
609.11	Vertical Curb Type 1	LF	100
609.12	Vertical Curb Type 1 - Circular	LF	25
609.234	Terminal Curb Type 1 - 4 Foot	EA	2
609.238	Terminal Curb Type 1 - 8 Foot	EA	10
609.2381	Terminal Curb Type 1 - 8 Foot Circular	EA	8
609.31	Curb Type 3	LF	240
609.34	Curb Type 5	LF	300
609.35	Curb Type 5 - Circular	LF	180
609.38	Reset Curb Type 1	LF	310
609.40	Reset Curb Type 5	LF	370
615.07	Loam	CY	38
618.13	Seeding Method Number 1	UN	4
619.12	Mulch	UN	4
626.11	Precast Concrete Junction Box	EA	23
626.21	Metallic Conduit	LF	200
626.22	Non-Metallic Conduit	LF	1850
626.35	Controller Cabinet Foundation	EA	5
626.421	24-Inch Foundation	LF	175
626.46	48" Diameter Foundation	LF	185.5
626.501	Spread Footing Foundation	CY	6
627.18	12 Inch Solid White Pavement Marking Line	LF	780
627.733	4" White or Yellow Painted Pavement Marking Line	LF	13100
627.75	White Pavement & Curb Markings	SF	3830
627.77	Removing Existing Pavement Markings	SF	1592
627.78	Temporary Pavement Marking Line, White or Yellow	LF	730
629.05	Hand Labor, Straight Time	HR	80
631.12	All Purpose Excavator (Including Operator)	HR	80
643.71	Traffic Signal Modification: Main St & Forest St	LS	1
643.80	Traffic Signal at: Main St & Hamois Ave	LS	1
643.80	Traffic Signal at: Hamois Ave & Cumberland St	LS	1
643.80	Traffic Signal at: Cumberland St & Warren Ave	LS	1
643.80	Traffic Signal at: Cumberland St & Main St	LS	1
643.81	Traffic Signal Control System	LS	1
643.83	Video Detection System: Main St & Hamois Ave	LS	1
643.83	Video Detection System: Hamois Ave & Cumberland St	LS	1
643.83	Video Detection System: Cumberland St & Warren Ave	LS	1
643.83	Video Detection System: Cumberland St & Main St	LS	1
643.83	Video Detection System: Main St & Forest St	LS	1
643.90	Interconnect Wire: 12-Strand (5,000 LF)	EA	1
643.91	Mast Arm Pole	EA	15
643.92	Pedestal Pole	EA	25
645.106	Demount Regulatory, Warning, Confirmation and Route Marker Assembly	EA	64
645.108	Demount Pole	EA	6
645.116	Reinstall Regulatory, Warning, Confirmation and Route Marker Sign	EA	7
645.251	Roadside Guide Sign, Type 1	SF	236
645.271	Regulatory, Warning, Confirmation and Route Marker Sign, Type 1	SF	600
645.306	Flexible Reflectorized Delineator	EA	96
652.33	Drum	EA	120
652.34	Cone	EA	75
652.35	Construction Signs	SF	500
652.36	Maintenance of Traffic Control Devices	CD	360
652.38	Flagger	HR	600
652.381	Traffic Officer	HR	360
652.41	Portable Changeable Message Sign	EA	4
656.75	Temporary Soil and Water Pollution Control	LS	1
658.20	Acrylic Latex Finish, Green	SY	383
659.10	Mobilization	LS	1

STATE OF MAINE
DEPARTMENT OF TRANSPORTATION
PROJECT NO. STP-1863(700)

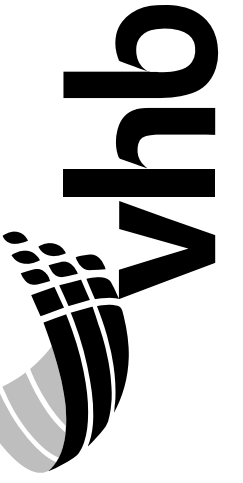

PROJ. MANAGER	B. KEEZER	BY	DATE
CHECKED-REVIEWED	ECF	JRD	05/19
DESIGNS DET AILED 02			
DESIGNS DET AILED 03			
REVISIONS 1			
REVISIONS 2			
REVISIONS 3			
REVISIONS 4			
FIELD CHANGES			

SIGNALIZATION OF
CUMBERLAND MILLS ROTARY
ESTIMATED QUANTITIES

SHEET NUMBER
2
OF 53

WIN
18637.00
HIGHWAY PLANS

GENERAL NOTES:

1. THE UTILITIES INVOLVED IN THIS CONTRACT ARE NOTED IN SPECIAL PROVISION 104.
2. ALL UTILITIES FACILITIES SHALL BE ADJUSTED OR RELOCATED BY THE RESPECTIVE UTILITIES UNLESS OTHERWISE NOTED IN COORDINATION WITH THE WORK OF THE CONTRACTOR.
3. THE CONTRACTOR SHALL PROVIDE THE RESIDENT AND THE CITY OF WESTBROOK WITH A SCHEDULE OF WORK AND WORK ZONE CONTROL PLANS FOR CONSTRUCTING THE TRAFFIC IMPROVEMENTS AT LEAST TWO WEEKS PRIOR TO THE COMMENCEMENT OF WORK.
4. FOR EASEMENTS, CONSTRUCTION LIMITS, AND RIGHT OF WAY LINES, REFER TO RIGHT OF WAY PLANS.
5. FLAT TOPS FOR CATCH BASINS ARE NOT ALLOWED UNLESS NOTED ON THE PLANS OR DIRECTED BY THE RESIDENT.
6. THE PROJECT GEOTECHNICAL REPORT TITLED GEOTECHNICAL DESIGN REPORT MAST ARM STRUCTURES, SOILS REPORT 2018-43C, NOVEMBER 5, 2018 CAN BE ACCESSED AT THE MAINEDOT WEBSITE [HTTP://WWW.MAINE.GOV/MDOT/CONTRACTORS/](http://www.maine.gov/mdot/contractors/).
7. GEOTECHNICAL INFORMATION FURNISHED OR REFERRED TO IN THE BID DOCUMENTS IS FOR THE USE OF THE BIDDERS. NO ASSURANCE IS GIVEN THAT THE INFORMATION OR INTERPRETATIONS WILL BE REPRESENTATIVE OF THE ACTUAL SUBSURFACE CONDITIONS THROUGHOUT THE CONSTRUCTION SITE. MAINEDOT WILL NOT BE RESPONSIBLE FOR ANY INTERPRETATIONS OR CONCLUSION DRAWN FROM THE GEOTECHNICAL INFORMATION, THE BORING LOGS PROVIDED IN THE BID DOCUMENTS (IF ANY) PRESENT FACTUAL AND INTERPRETIVE SUBSURFACE INFORMATION COLLECTED AT DISCRETE LOCATIONS. DATA PROVIDED MAY NOT BE REPRESENTATIVE OF THE SUBSURFACE CONDITIONS BETWEEN BORING LOCATIONS.
8. THE MAINE DEPARTMENT OF ENVIRONMENTAL PROTECTION (MDEP) HAS REPORTED SPILLS AND RELEASES INVOLVING PETROLEUM PRODUCTS ADJACENT TO THE PROJECT. IN PARTICULAR, ROUGHLY BETWEEN MAINE DEPARTMENT OF TRANSPORTATION (MAINEDOT) STATION 32+50 TO ROUGHLY MAINEDOT STATION 33+50 RIGHT OF CENTER, BASED ON THE SCOPE OF WORK AND SUBSURFACE WORK BY OTHERS, AVAILABLE DATA SUGGESTS THAT THIS CONTAMINATION MAY ONLY BE ADJACENT TO AND DEEPER IN THE IMMEDIATE AREAS OF ANY EXCAVATION PROPOSED BY THE MAINEDOT AT THESE LOCATIONS. HOWEVER, IN LIGHT OF THESE FINDINGS, THE CONTRACTOR SHALL EMPLOY APPROPRIATE HEALTH AND SAFETY MEASURES TO PROTECT ITS WORKERS AGAINST HAZARDS ASSOCIATED WITH WORKING NEAR PETROLEUM -IMPACTED SOILS. FURTHERMORE, THE CONTRACTOR SHALL REMAIN ALERT FOR ANY ADDITIONALLY EVIDENCE OF CONTAMINATION. IF THE CONTRACTOR ENCOUNTERS EVIDENCE OF SOIL OR GROUNDWATER CONTAMINATION, THE CONTRACTOR SHALL SECURE THE EXCAVATION, STOP WORK IN THE CONTAMINATED AREA, AND IMMEDIATELY NOTIFY THE RESIDENT. THE RESIDENT SHALL CONTACT THE MAINEDOT SENIOR GEOLOGIST AT (207)624-3100 AND THE MDEP AT 800-482-0777. WORK MAY ONLY CONTINUE WITH AUTHORIZATION FROM THE RESIDENT.
9. THE CONTRACTOR IS RESPONSIBLE FOR FINDING EXACT LOCATIONS OF EXISTING UTILITIES PRIOR TO CONSTRUCTION. THE CONTRACTOR SHALL CONTACT DIG-SAFE AND APPROPRIATE AUTHORITIES PRIOR TO ANY SUBSURFACE ACTIVITIES.
10. THE ENGINEER AND MAINEDOT SHALL HAVE THE RIGHT AND AUTHORITY TO DETERMINE THE ACCEPTABILITY OF WORK AND MATERIALS IN PROGRESS OR COMPLETED AND SHALL HAVE THE RIGHT TO REJECT ANY WORK OR MATERIALS WHICH DO NOT CONFORM, IT ITS SOLE OPINION, TO THE PLANS OR SPECIFICATIONS.
11. ALL SIGNING, SIGNAL AND STRIPING MATERIALS AND PLACEMENT SHALL CONFORM TO THE MAINEDOT STANDARD SPECIFICATIONS, SUPPLEMENTAL SPECIFICATIONS AND STANDARD DETAILS AND WITH THE FEDERAL HIGHWAY ADMINISTRATION MANUAL ON UNIFORM TRAFFIC CONTROL DEVICES (MUTCD) DATED 2009, AS AMENDED.
12. CONTRACTOR SHALL BE RESPONSIBLE FOR OBTAINING ANY NECESSARY OPENING PERMITS.
13. ALL EXISTING DRIVEWAY ACCESSES SHALL BE MAINTAINED AT ALL TIMES.

COMMON EXCAVATION FOR ESTIMATE			
COMMON EXCAVATION (FROM CROSS SECTIONS)		1,581	
TOTAL COMMON EXCAVATION (FOR ESTIMATE)			1,581
FILL FOR BORROW CALCULATIONS			
COMMON FILL (FROM CROSS SECTIONS)		43	
TOTAL FILL			43
ROCK EXCAVATION FOR ESTIMATE			
ROCK EXCAVATION (FROM CROSS SECTIONS)		0	
TOTAL ROCK EXCAVATION			0
AVAILABLE COMMON EXCAVATION FOR BORROW CALCULATIONS			
(1) TOTAL COMMON EXCAVATION			1,581
DEDUCTIONS:			
GRUBBING IN CUT		0	
GRUBBING IN FILL		0	
LOAM SALVAGE IN CUT		0	
LOAM SALVAGE IN FILL		0	
UNDERCUT		0	
MUCK EXCAVATION		0	
PAVEMENT SALVAGE (CUT & FILL)		206	
(2) TOTAL DEDUCTIONS			206
TOTAL AVAILABLE COMMON EXCAVATION (1) MINUS (2)			1,375
TOTAL AVAILABLE STRUCT. EXCAVATIONS (USUALLY UNDERDRAIN ONLY)			0
RIPRAP EXCAVATION			0
TOTAL AVAILABLE NON-ROCK EXCAVATION			1,375
COMPUTATION FOR COMMON BORROW FOR ESTIMATE			
(3) TOTAL FILL			43
TOTAL AVAIL. NON-ROCK EXCAV.	1,375 x 0.90 =	1,238	
TOTAL AVAIL. ROCK EXCAV.	0 x 1.30 =	0	
TOTAL AVAIL. STR. ROCK EXCAV.	0 x 1.30 =	0	
TOTAL WASTE MATERIAL TO BE UTILIZED	0 x 0.00 =	0	
(4) TOTAL AVAILABLE EXCAVATION			1,238
BORROW NEEDED = TOTAL FILL MINUS TOTAL AVAILABLE EXCAVATION			-1,195
TOTAL SURPLUS =			1,195

STATE OF MAINE DEPARTMENT OF TRANSPORTATION PROJECT NO. STP-1863(700)	HIGHWAY PLANS WIN 18637.00
	
SIGNALIZATION OF CUMBERLAND MILLS ROTARY	GENERAL NOTES
SHEET NUMBER 3	
OF 53	

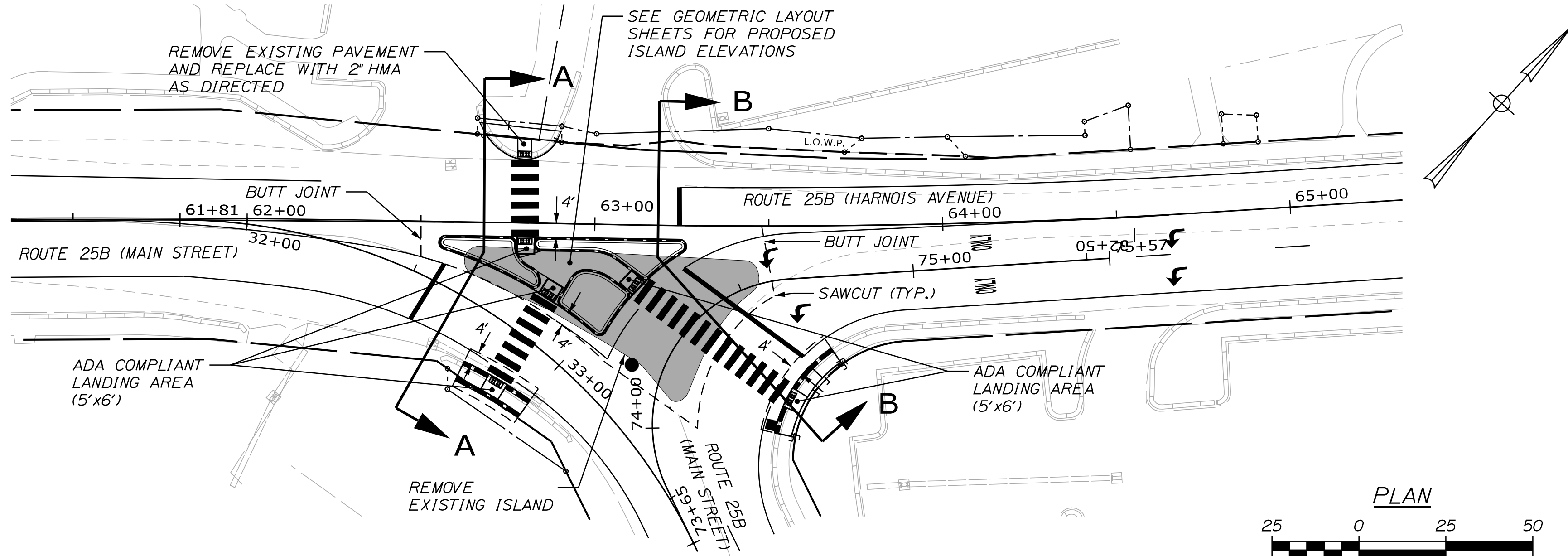

HARNOIS AVENUE & MAIN STREET PLAN

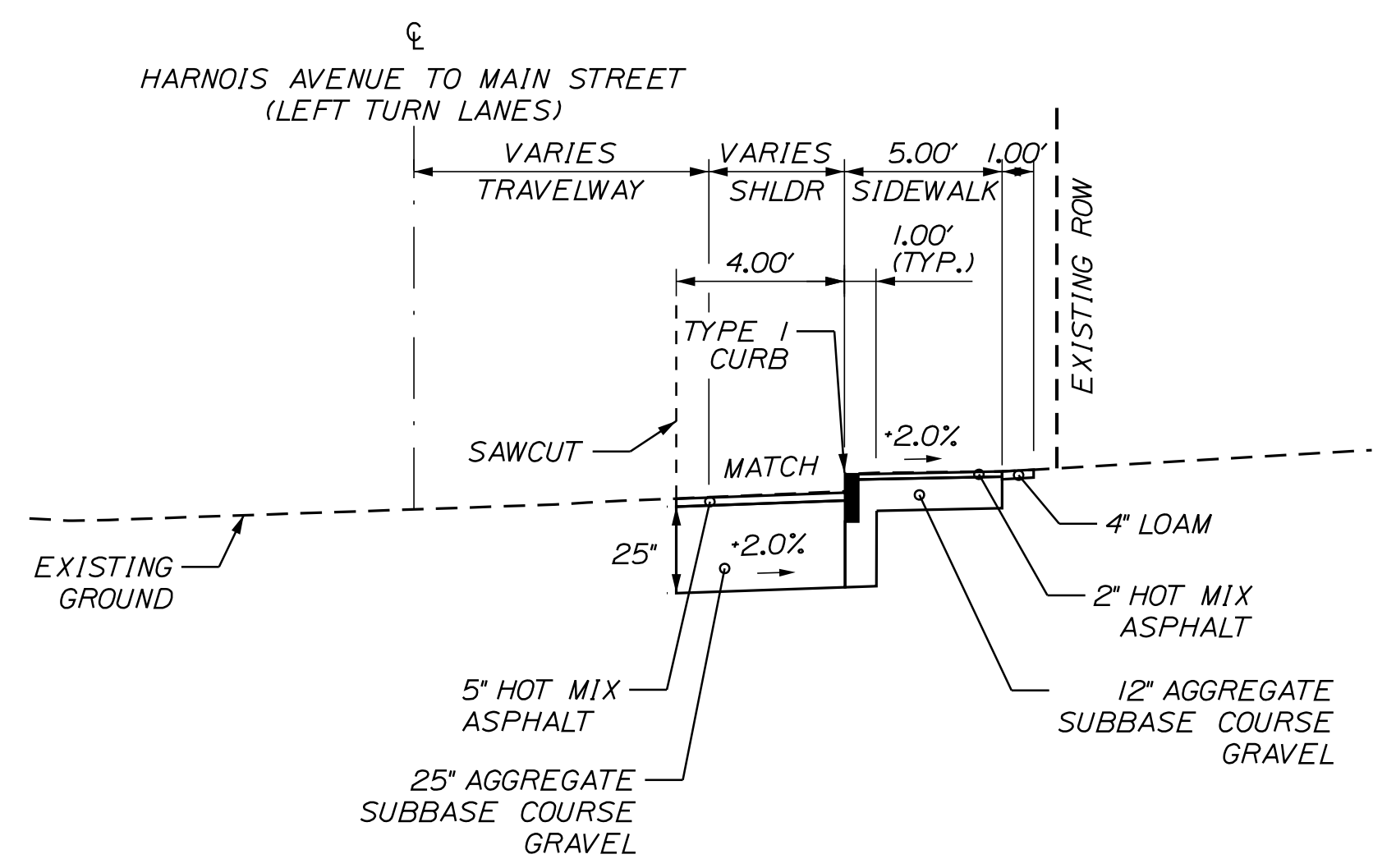

SHOULDER RECONSTRUCTION - CURB TYPE 1 STA. 73+95 TO 74+65 RT (N.T.S.)

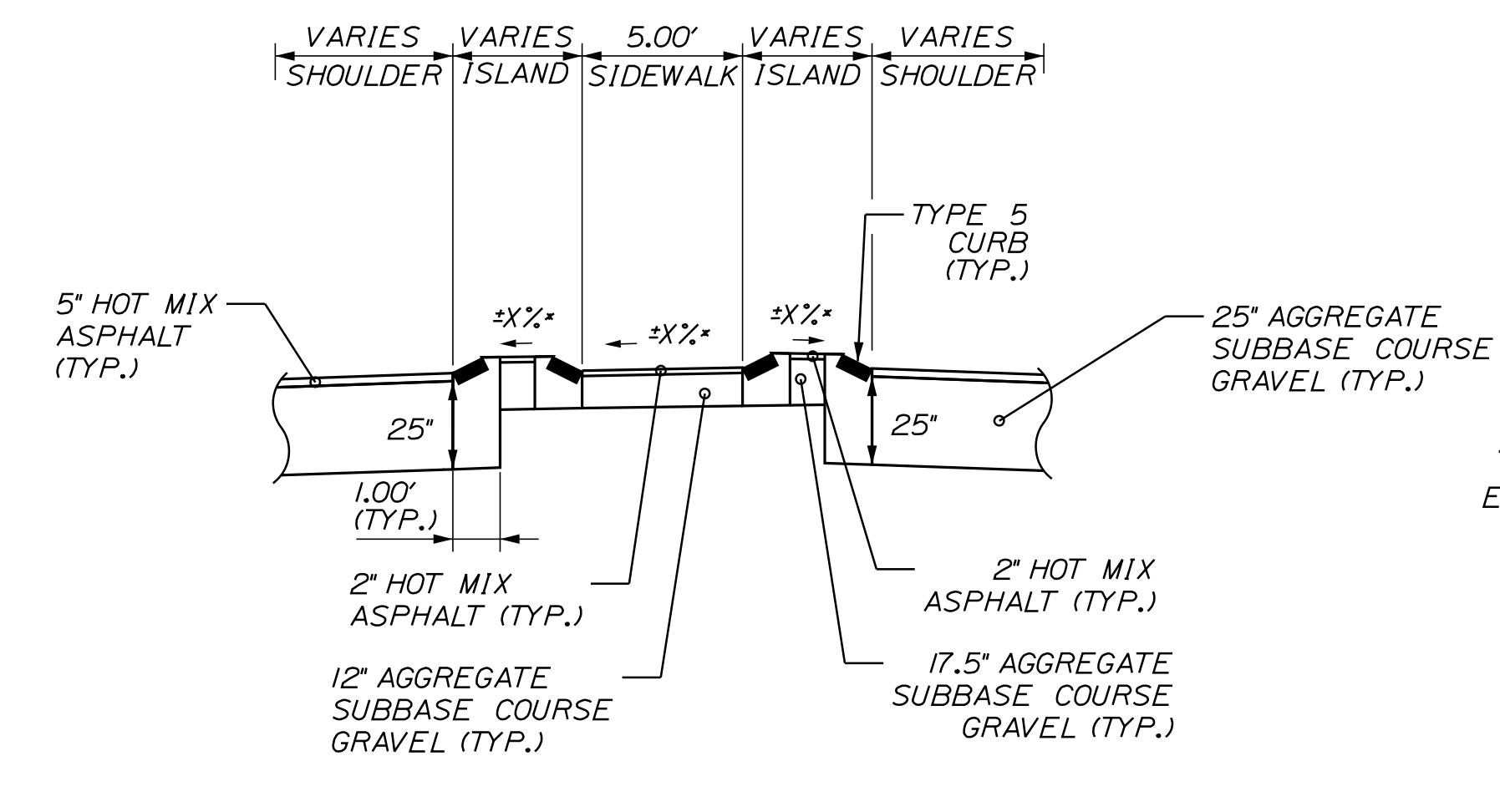

INTERIOR ISLAND DETAIL (N.T.S.)

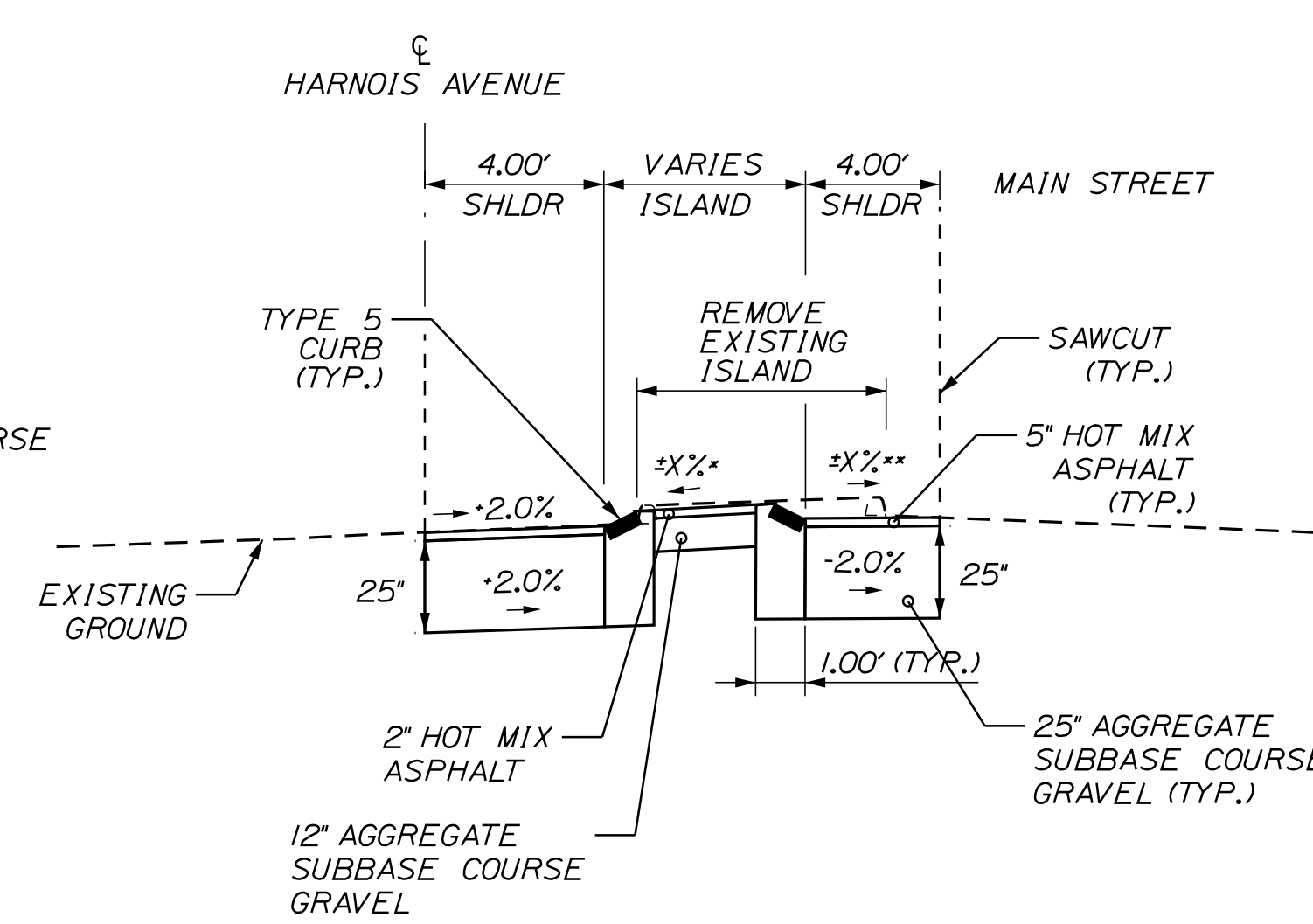

HARNOIS AVENUE & MAIN STREET DETAIL A-A (N.T.S.)

MAIN STREET SUPERELEVATION TABLE	
LT SHLDR %	STATION
	START
MATCH	32+50
0.6	32+75
4.0	33+00
MATCH	33+25
	END

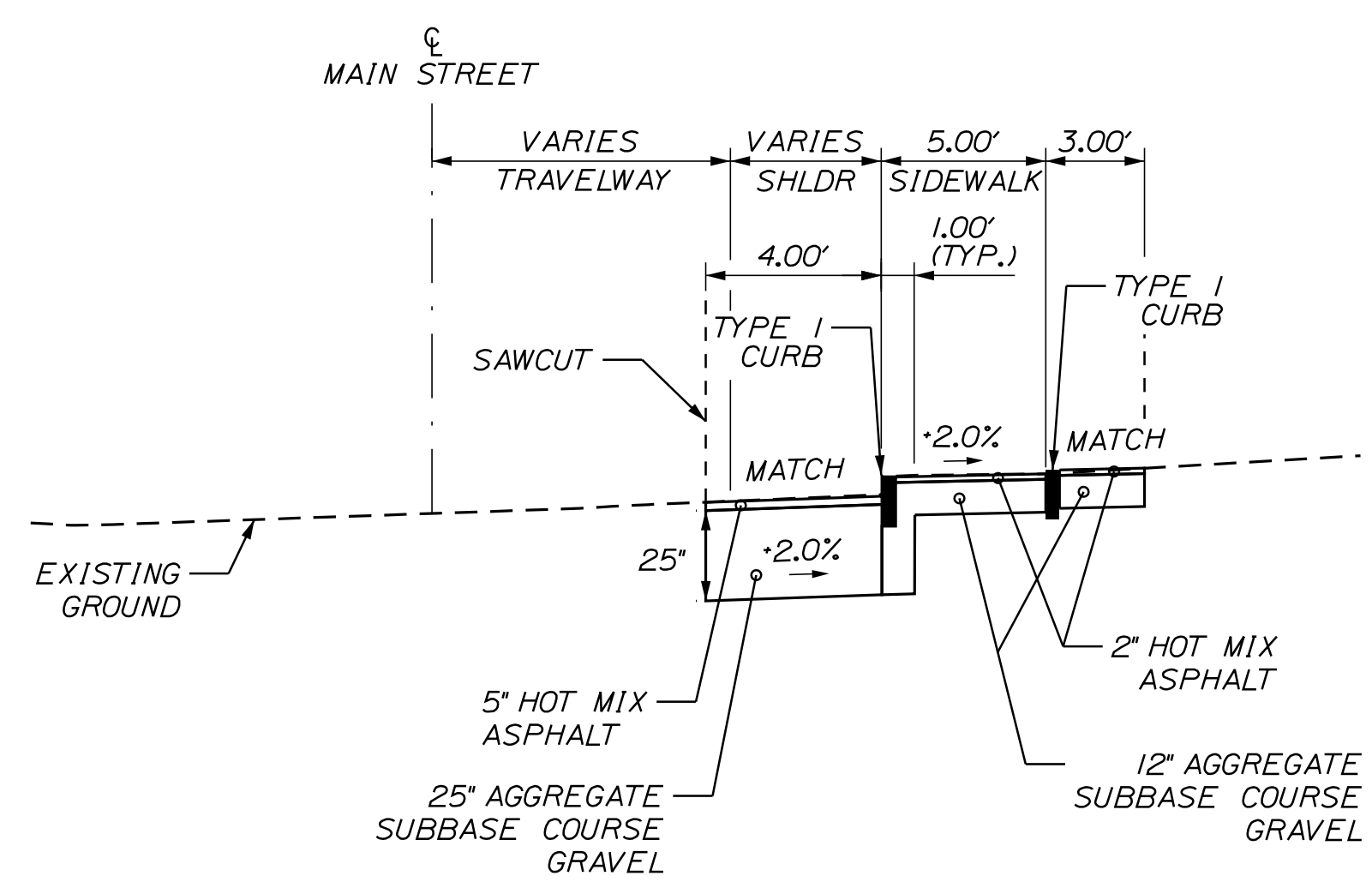

SHOULDER RECONSTRUCTION - CURB TYPE 1 STA. 32+76 TO 33+00 RT (N.T.S.)

- NOTES:
- * SEE GEOMETRIC LAYOUT SHEETS FOR PROPOSED ISLAND ELEVATIONS.
 - ** SEE SUPERELEVATION TABLE FOR SLOPES.
 - 1. THE PAVEMENT AND BASE DEPTHS SHOWN ON THE PLANS ARE INTENDED TO BE NOMINAL.
 - 2. THE STATIONING SHOWN UNDER EACH TYPICAL IS APPROXIMATE.
 - 3. 4" OF LOAM SHALL BE USED IN ALL DISTURBED AREAS.
 - 4. BUTT JOINT PAYMENT SHALL BE INCIDENTAL TO ITEM 403.208 HMA 12.5MM.

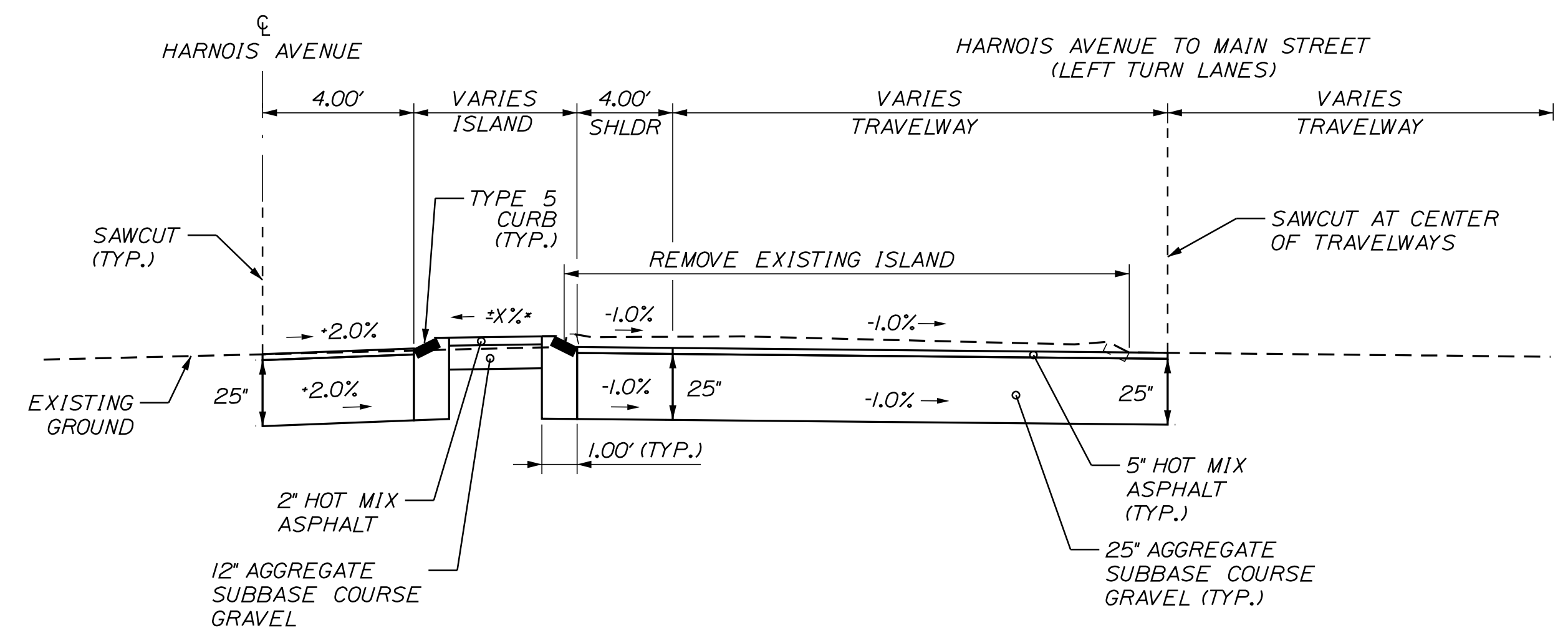

HARNOIS AVENUE & HARNOIS AVENUE TO MAIN STREET DETAIL B-B (N.T.S.)



PROJ. MANAGER	B. KEEZER	DATE	05/18
DESIGN DETAILED	ECF		
CHECKED/REVIEWED	JRD		
DESIGN DETAILED			
DESIGN DETAILED			
REVISIONS 1			
REVISIONS 2			
REVISIONS 3			
REVISIONS 4			
FIELD CHANGES			

Date: 2/17/2020

Username: jrobert

Division: HIGHWAY

Filename: ... \HIGHWAY\MSTAV005_Detail_02.dgn

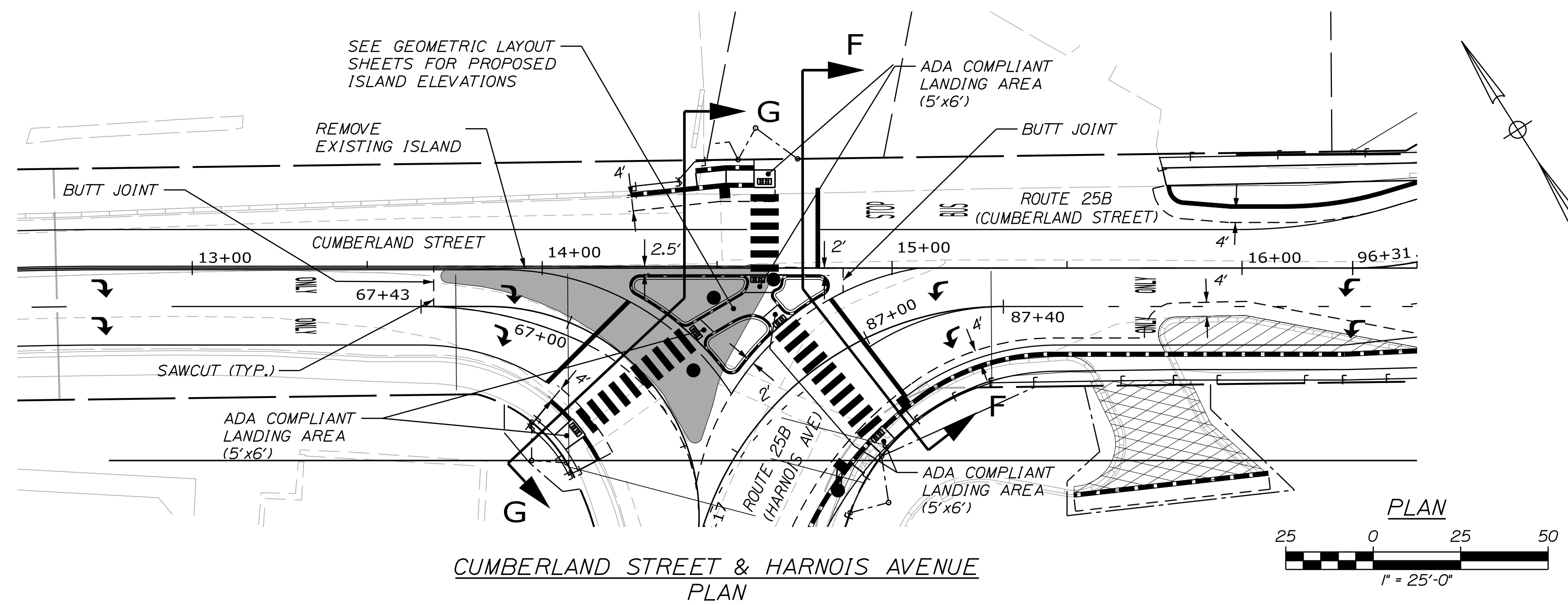

CUMBERLAND STREET & HARNOIS AVENUE PLAN

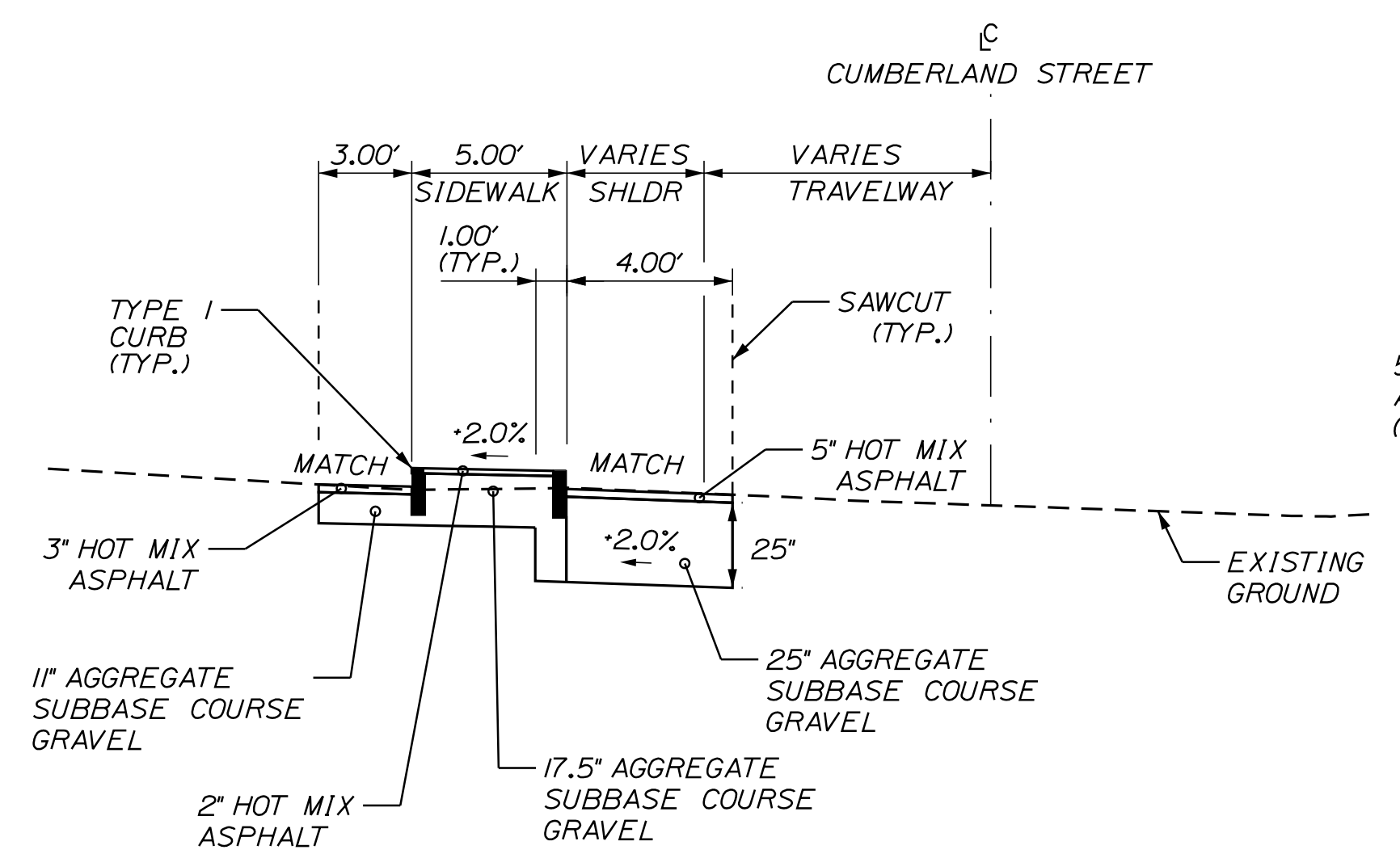

SHOULDER RECONSTRUCTION - CURB TYPE 1
STA. 14+44 TO 14+67 LT
(N.T.S.)

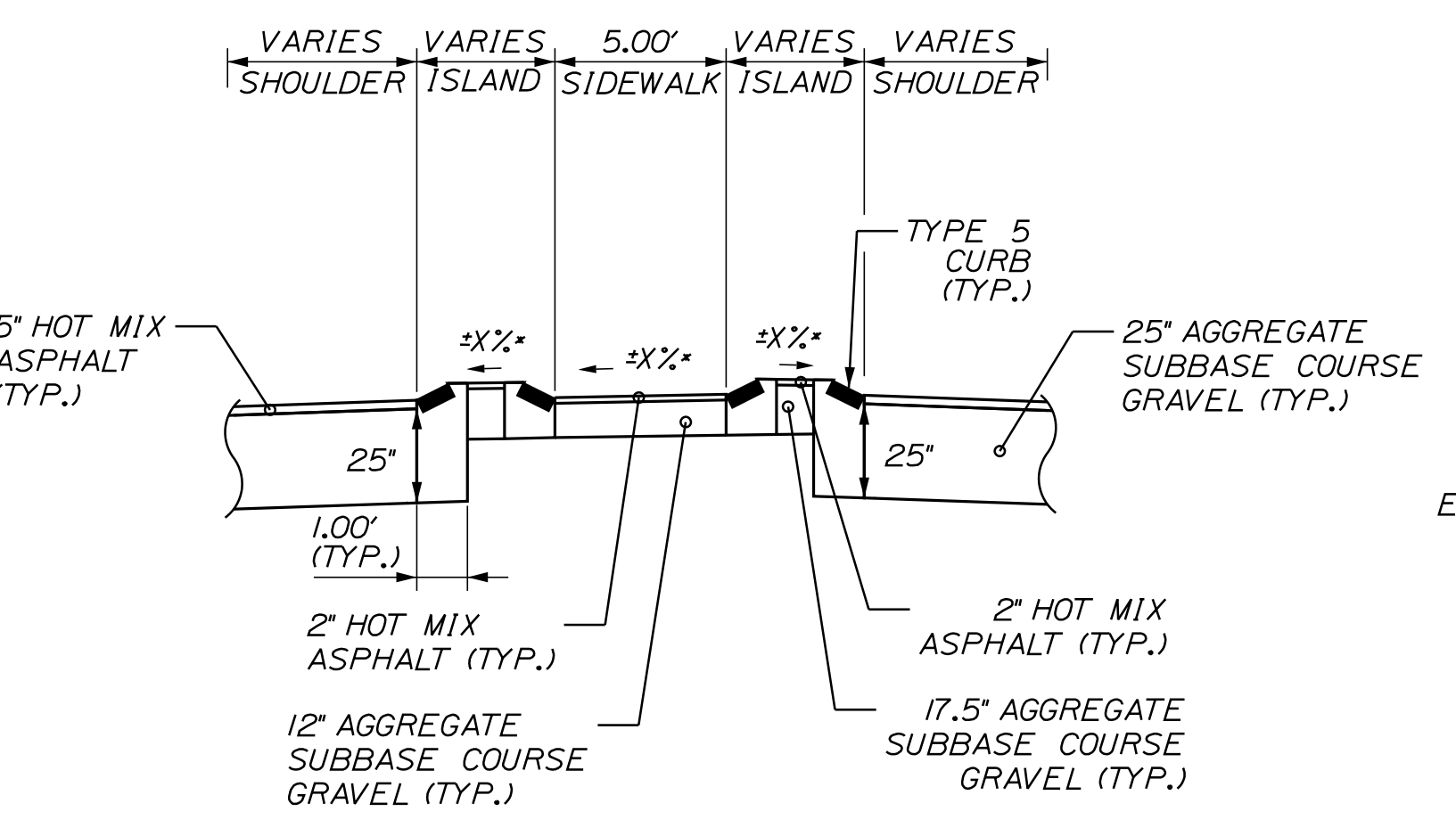

INTERIOR ISLAND
DETAIL
(N.T.S.)

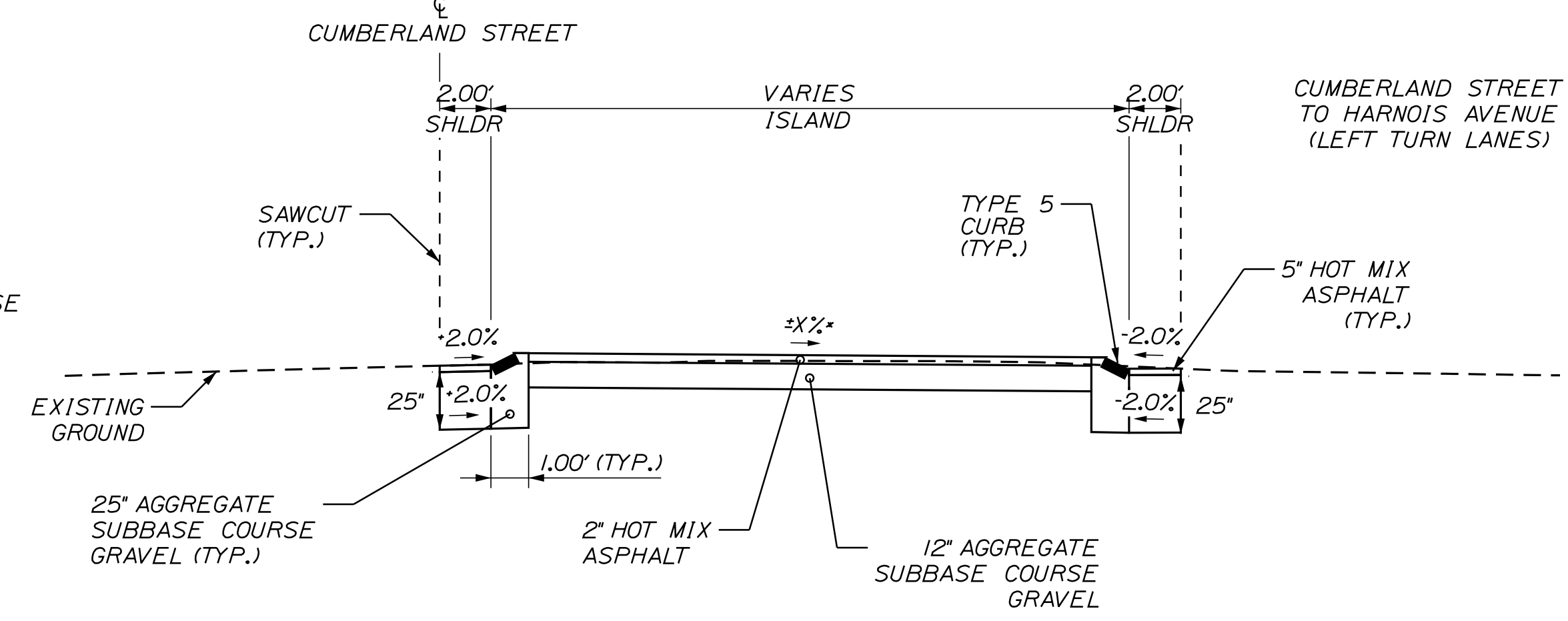

CUMBERLAND STREET & CUMBERLAND STREET TO HARNOIS AVENUE
DETAIL F-F
(N.T.S.)

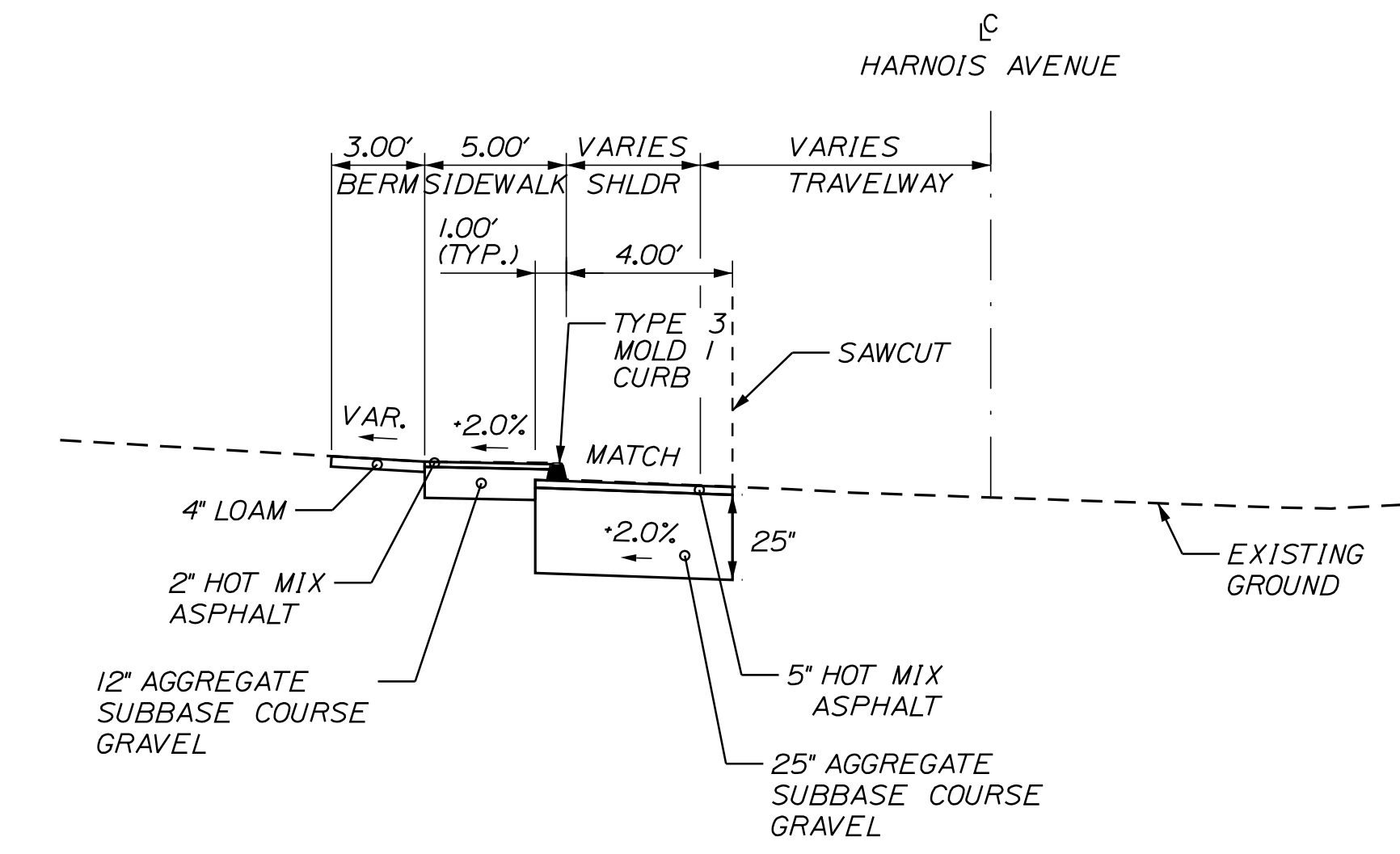

SHOULDER RECONSTRUCTION - CURB TYPE 3
STA. 66+60 TO 66+93 LT
(N.T.S.)

- NOTES:**
- * SEE GEOMETRIC LAYOUT SHEETS FOR PROPOSED ISLAND ELEVATIONS.
 - ** SEE SUPERELEVATION TABLE FOR SLOPES.
 - 1. THE PAVEMENT AND BASE DEPTHS SHOWN ON THE PLANS ARE INTENDED TO BE NOMINAL.
 - 2. THE STATIONING SHOWN UNDER EACH TYPICAL IS APPROXIMATE.
 - 3. 4" OF LOAM SHALL BE USED IN ALL DISTURBED AREAS.
 - 4. BUTT JOINT PAYMENT SHALL BE INCIDENTAL TO ITEM 403.208 HMA 12.5MM.

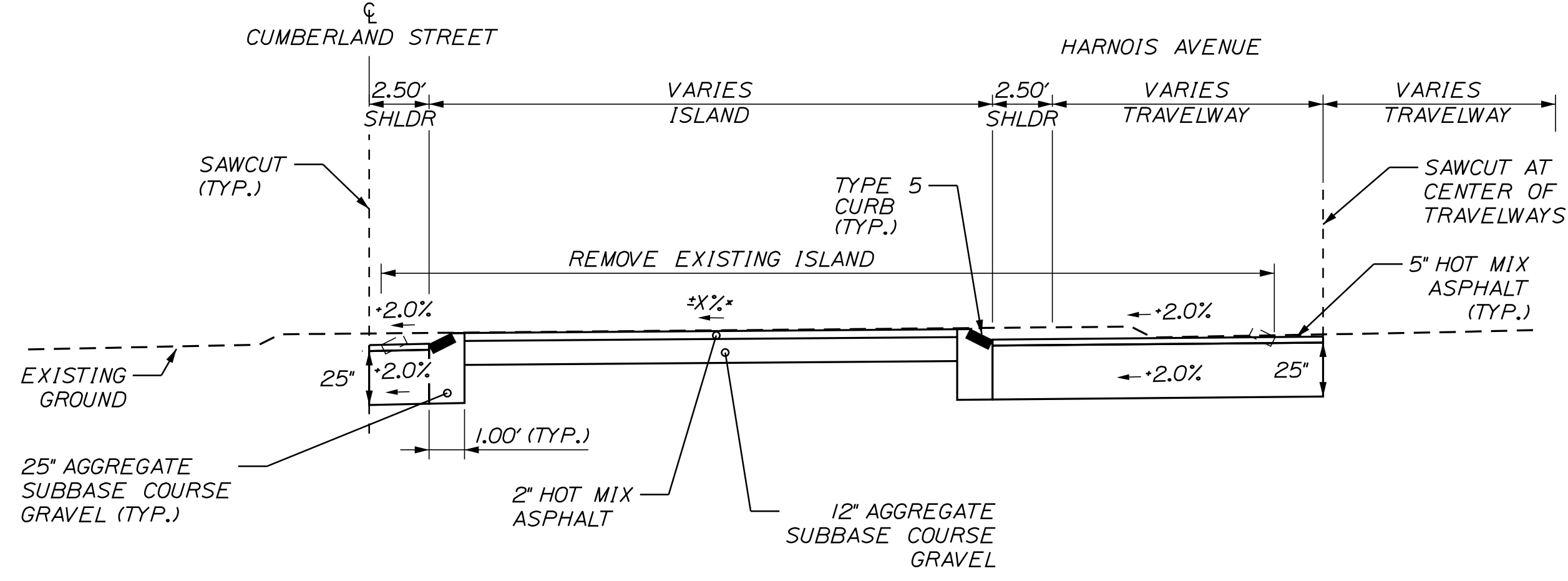

CUMBERLAND STREET & HARNOIS AVENUE
DETAIL G-G
(N.T.S.)

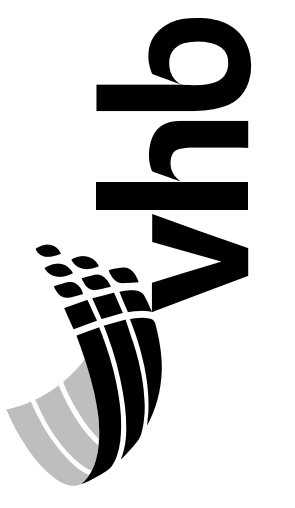

PROJ. MANAGER	B. KEEZER	DATE
DESIGN/REVIEWED	ECF	05/19
DESIGN/DETAILED		
DESIGN/DETAILED		
REVISIONS 1		
REVISIONS 2		
REVISIONS 3		
REVISIONS 4		
FIELD CHANGES		

Date: 2/17/2020

Username: jrobert

Division: HIGHWAY

Filename: ... \HIGHWAY\MSTA\006_Detail_03.dgn

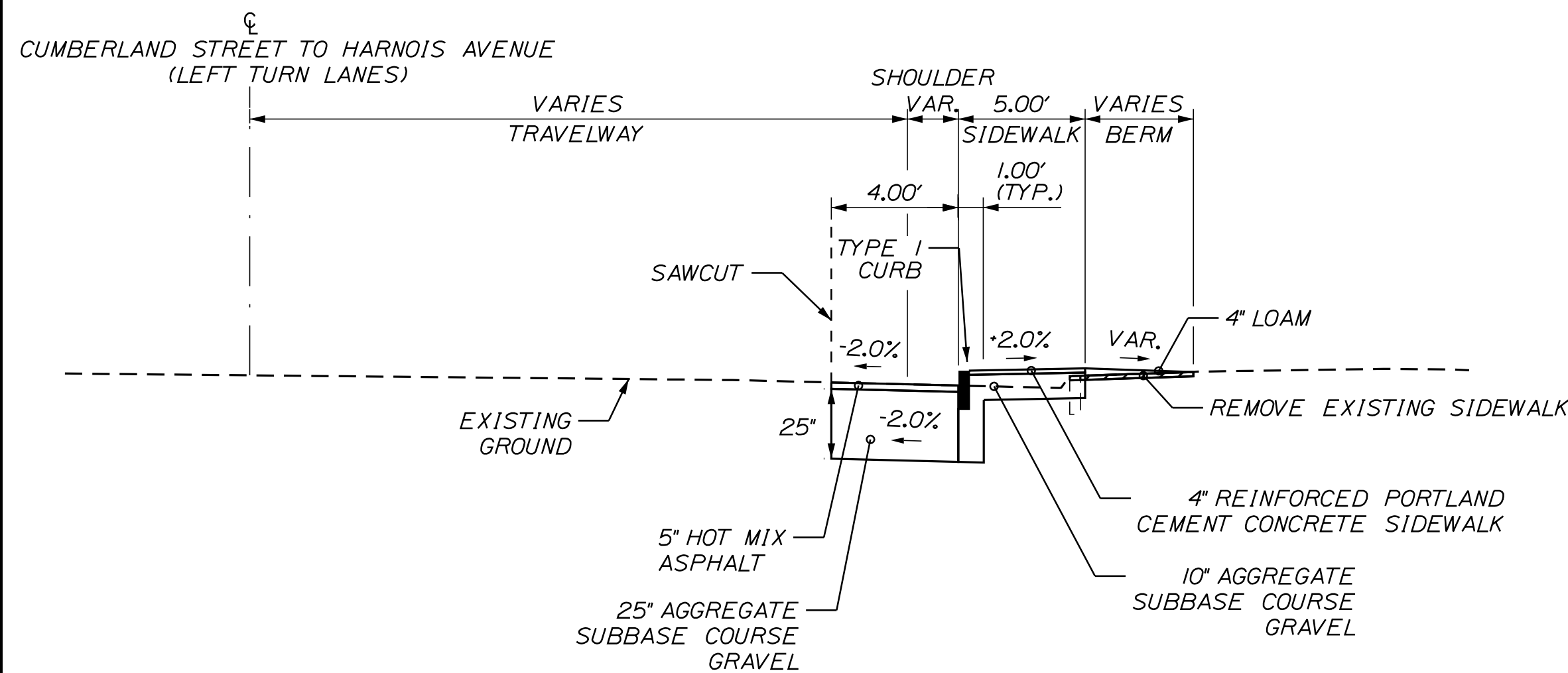
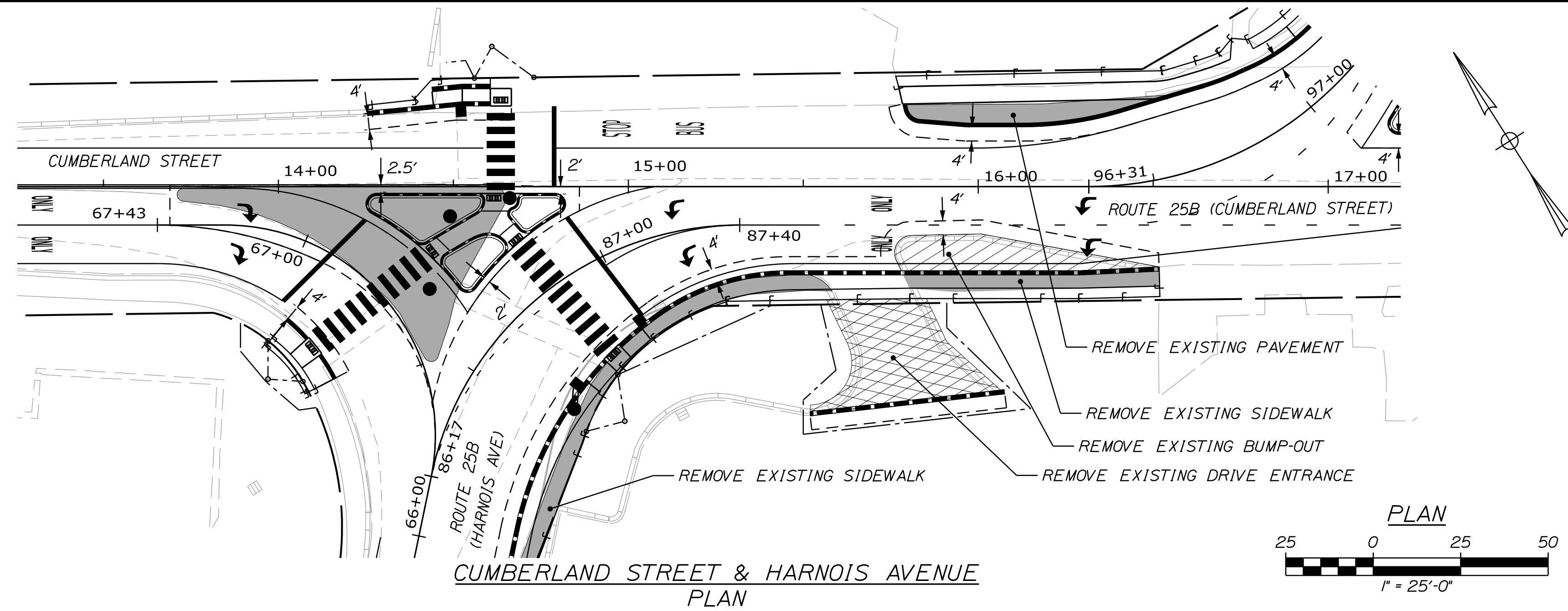

SHOULDER RECONSTRUCTION - CURB TYPE 1
HARNOIS AVENUE TO CUMBERLAND STREET
 STA. 65+78 TO 66+17 RT
 STA. 86+17 TO 87+40 RT
 STA. 15+32 TO 15+50 RT
 (N.T.S.)

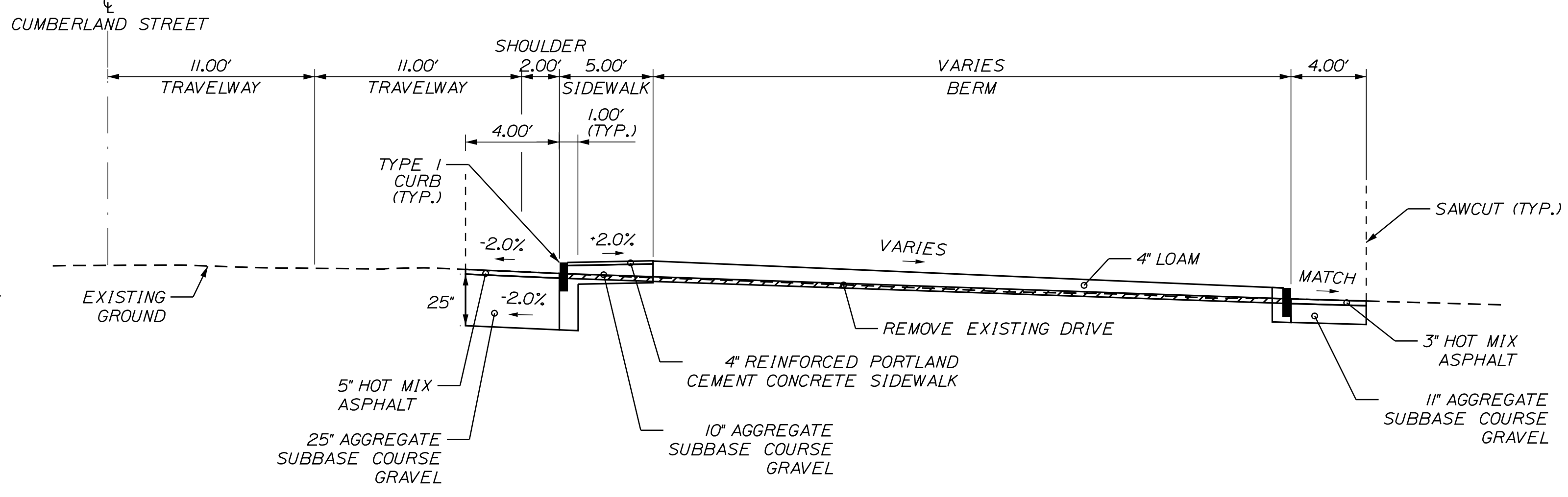

SHOULDER RECONSTRUCTION - CURB TYPE 1
CUMBERLAND STREET
 STA. 15+50 TO 15+75 RT
 (N.T.S.)

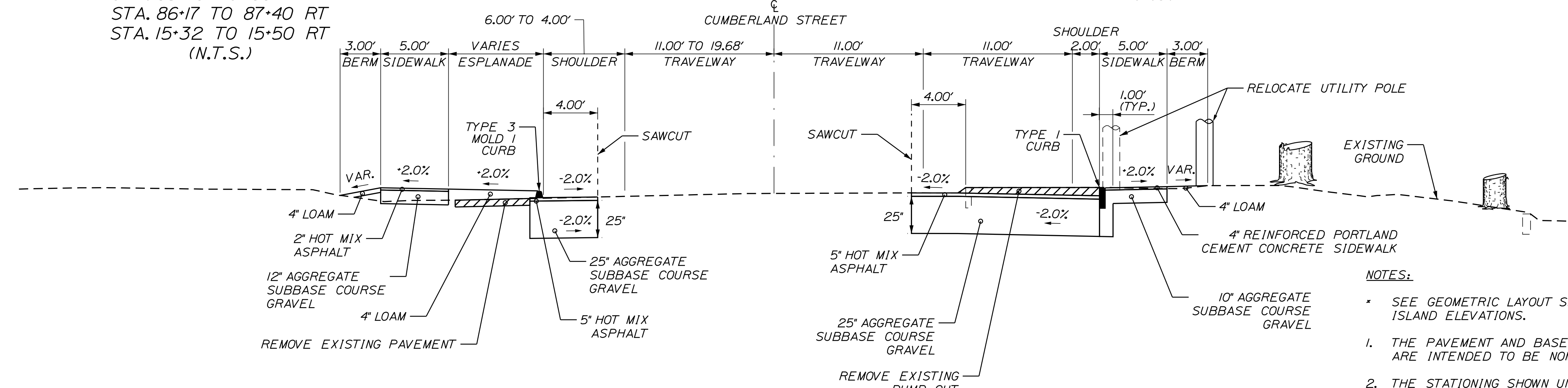

SHOULDER RECONSTRUCTION - CURB TYPE 1 & TYPE 3
CUMBERLAND STREET
 STA. 15+75 TO 16+50
 (N.T.S.)

- NOTES:**
- * SEE GEOMETRIC LAYOUT SHEETS FOR PROPOSED ISLAND ELEVATIONS.
 - 1. THE PAVEMENT AND BASE DEPTHS SHOWN ON THE PLANS ARE INTENDED TO BE NOMINAL.
 - 2. THE STATIONING SHOWN UNDER EACH TYPICAL IS APPROXIMATE.
 - 3. 4' OF LOAM SHALL BE USED IN ALL DISTURBED AREAS.
 - 4. BUTT JOINT PAYMENT SHALL BE INCIDENTAL TO ITEM 403.208 HMA 12.5MM.



PROJ. MANAGER	B. KEEZER	BY	DATE
DESIGN DETAILED	ECF	JRD	05/19
CHECKED			
DESIGN DETAILED			
DESIGN DETAILED			
REVISIONS 1			
REVISIONS 2			
REVISIONS 3			
REVISIONS 4			
FIELD CHANGES			

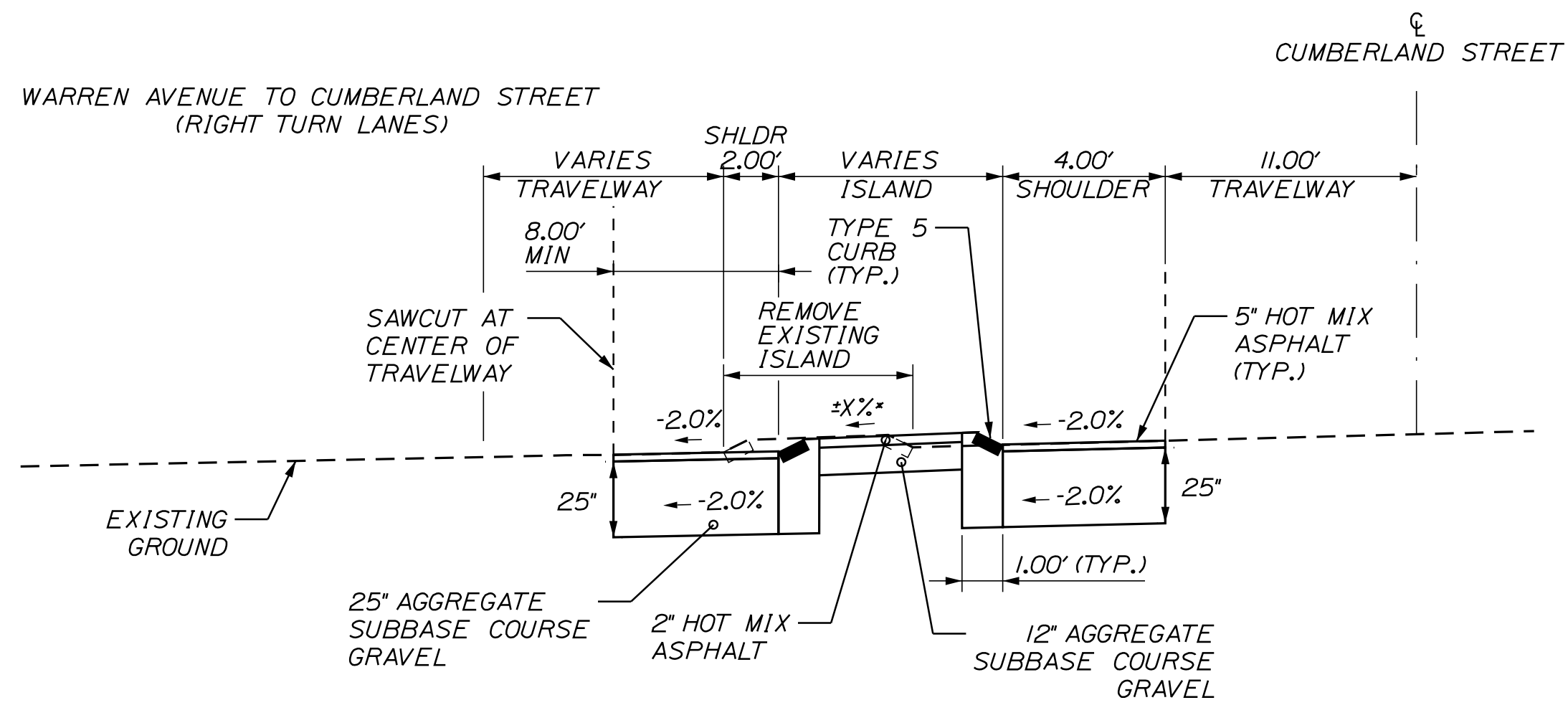
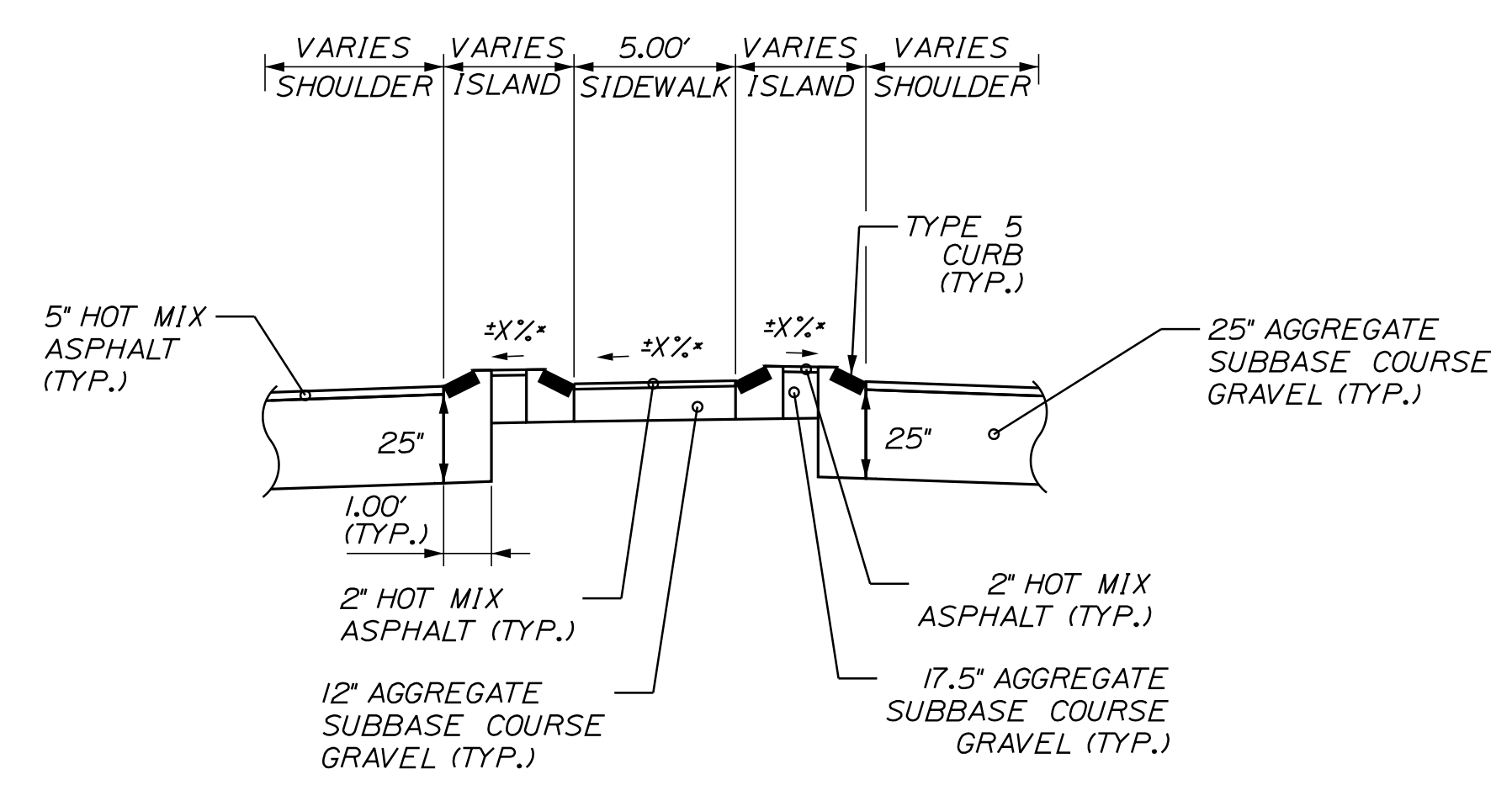
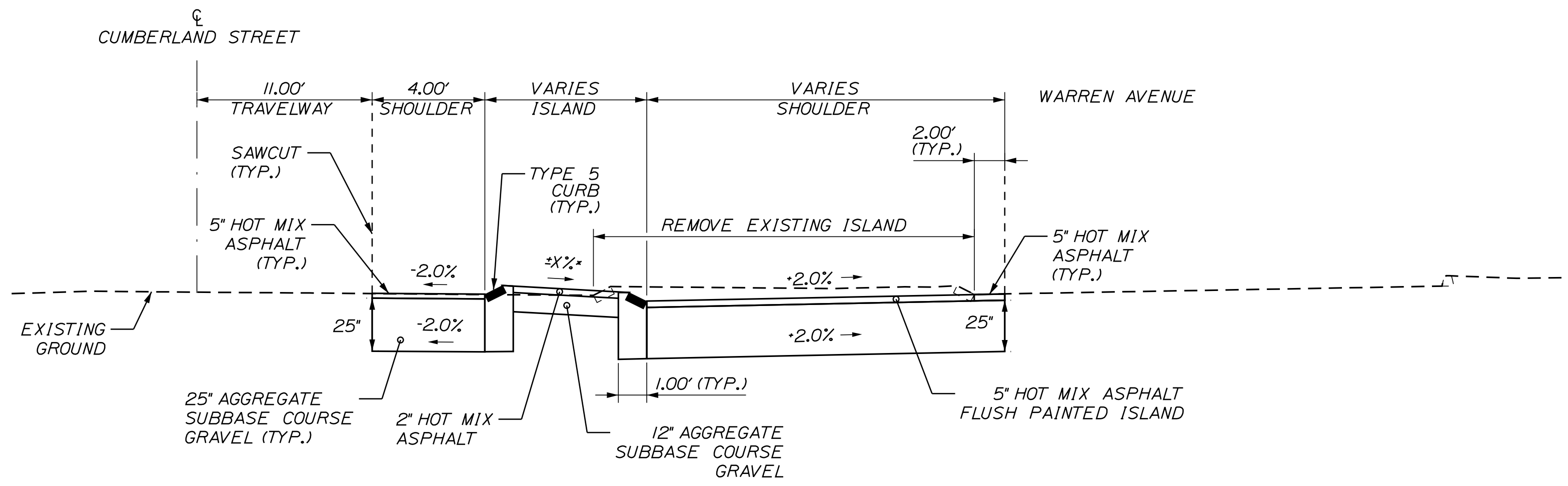
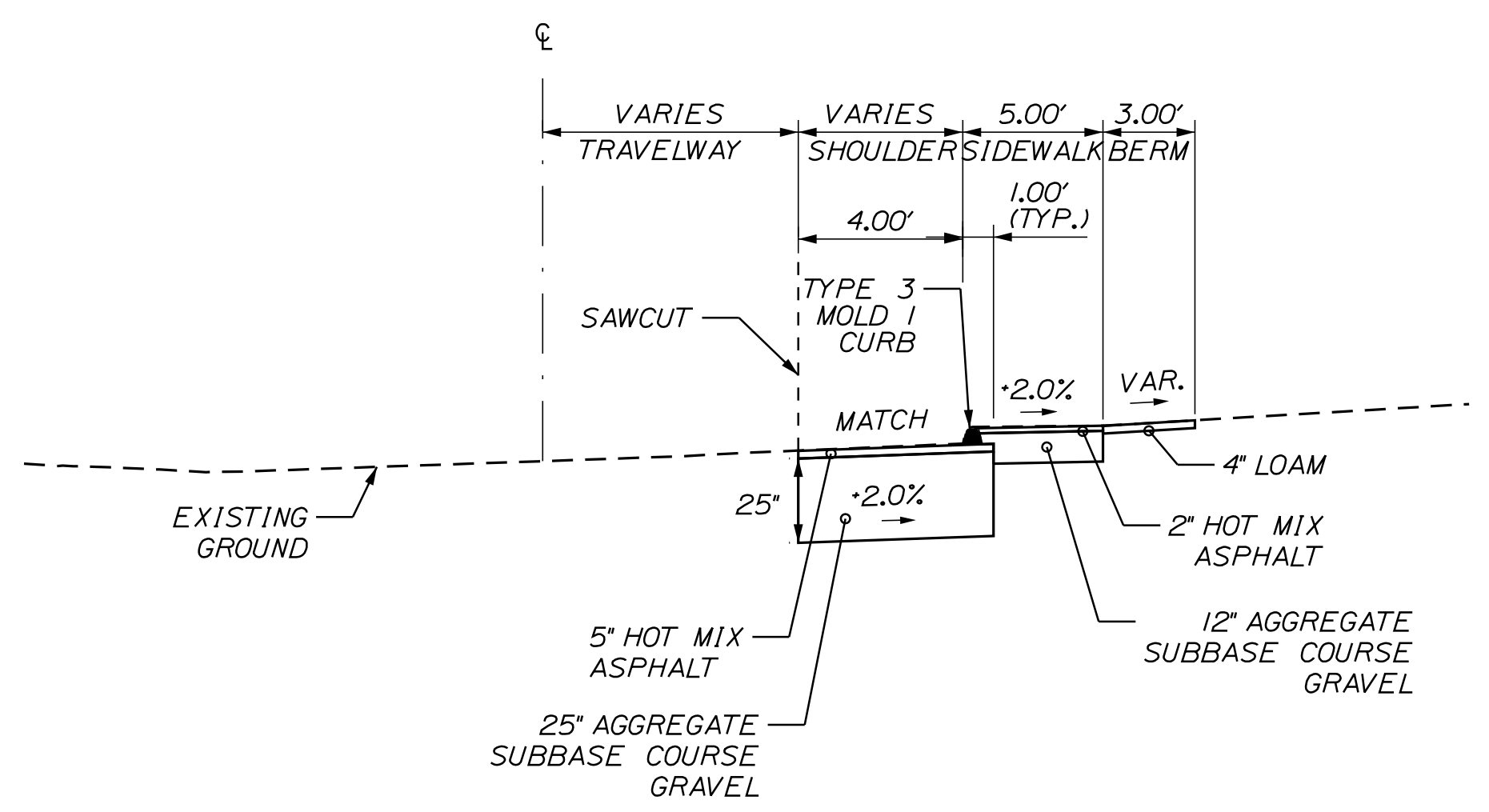
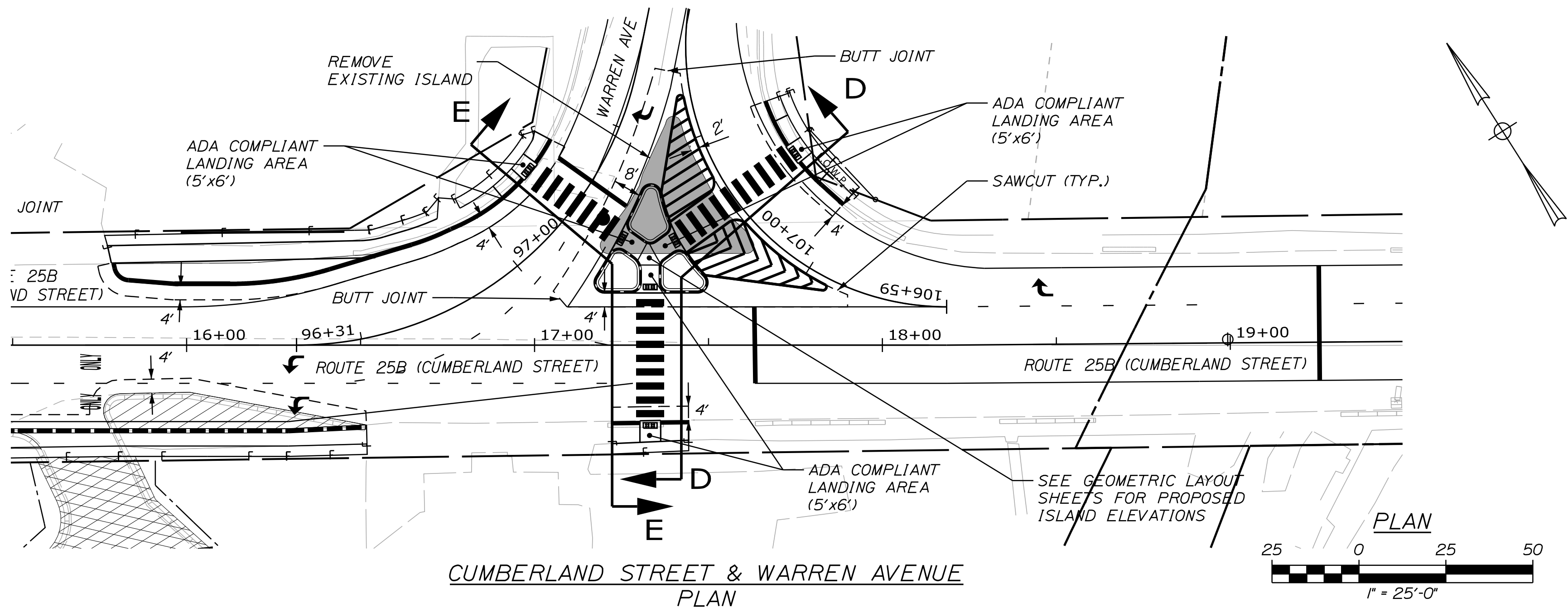

- NOTES:**
- * SEE GEOMETRIC LAYOUT SHEETS FOR PROPOSED ISLAND ELEVATIONS.
 - 1. THE PAVEMENT AND BASE DEPTHS SHOWN ON THE PLANS ARE INTENDED TO BE NOMINAL.
 - 2. THE STATIONING SHOWN UNDER EACH TYPICAL IS APPROXIMATE.
 - 3. 4" OF LOAM SHALL BE USED IN ALL DISTURBED AREAS.
 - 4. BUTT JOINT PAYMENT SHALL BE INCIDENTAL TO ITEM 403.208 HMA 12.5MM.



PROJ. MANAGER	B. KEEZER	BY	DATE
DESIGN DETAILED	ECF	JRD	05/19
CHECKED-REVIEWED			
DESIGN DETAILED			
DESIGN DETAILED			
REVISIONS 1			
REVISIONS 2			
REVISIONS 3			
REVISIONS 4			
FIELD CHANGES			

**SIGNALIZATION OF
CUMBERLAND MILLS ROTARY**

DETAILS (4 OF 6)

SHEET NUMBER

7

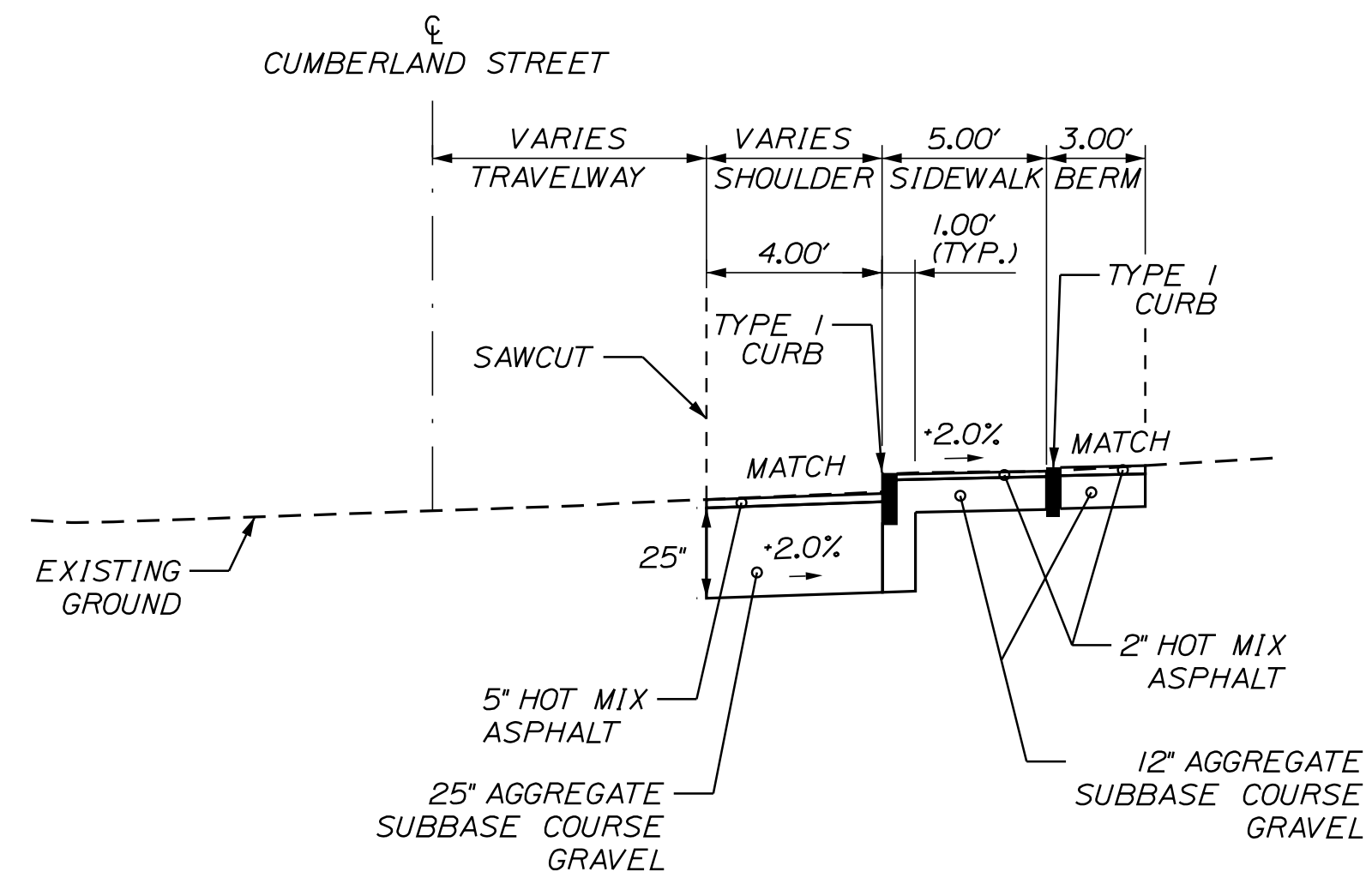
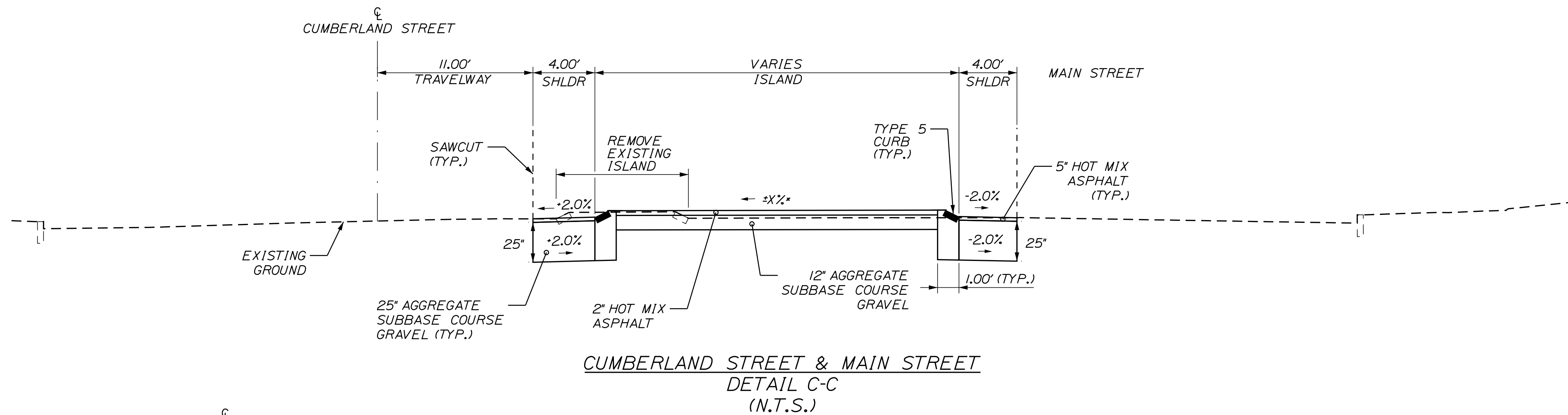
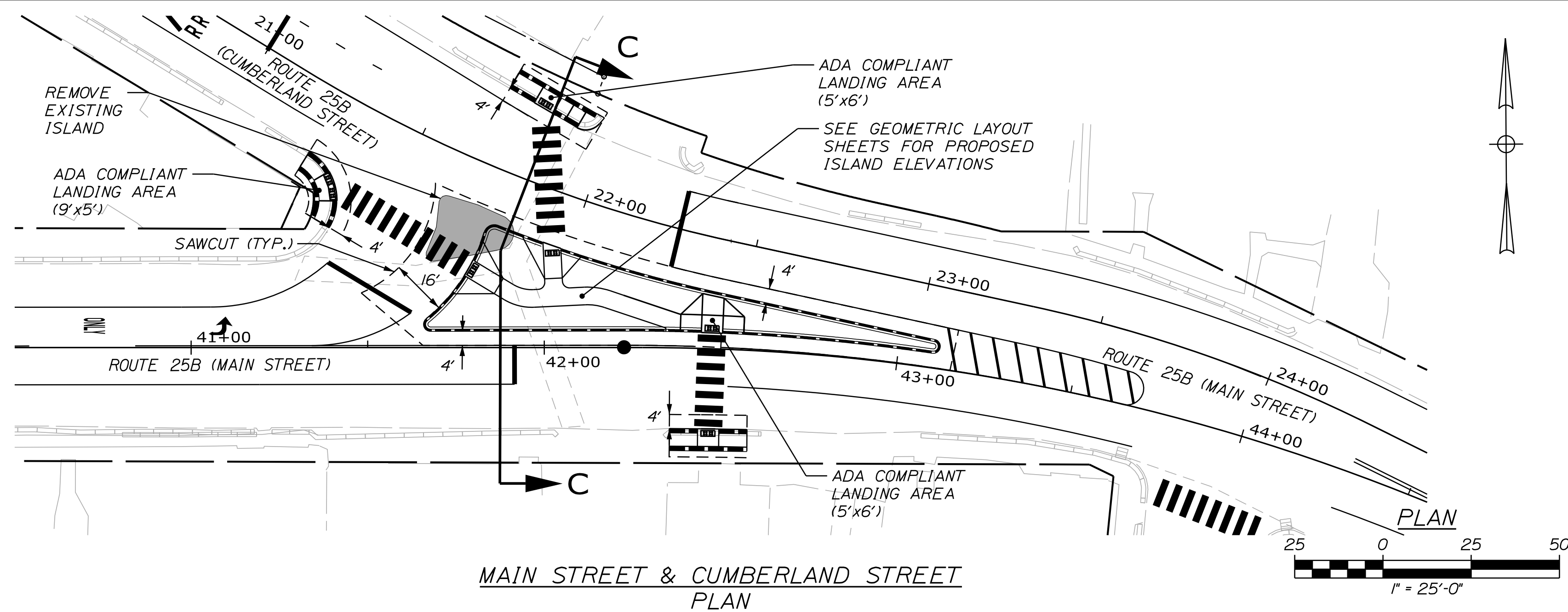

SHOULDER RECONSTRUCTION - CURB TYPE 1
 STA. 21+25 TO 21+43 RT
 STA. 21+67 TO 21+90 LT
 STA. 42+39 TO 42+56 RT
 (N.T.S.)

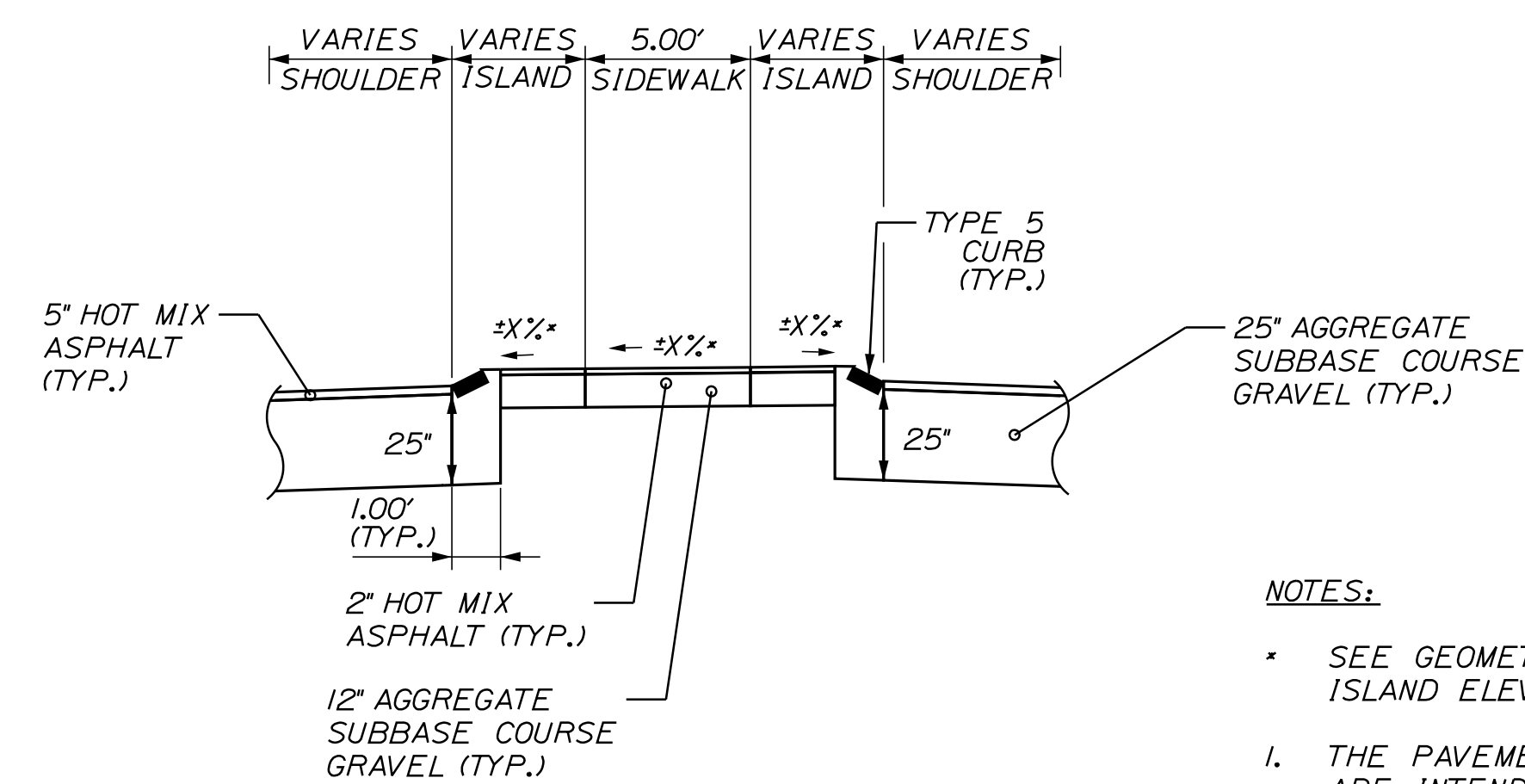

**INTERIOR ISLAND
DETAIL
(N.T.S.)**

NOTES:

- * SEE GEOMETRIC LAYOUT SHEETS FOR PROPOSED ISLAND ELEVATIONS.
- 1. THE PAVEMENT AND BASE DEPTHS SHOWN ON THE PLANS ARE INTENDED TO BE NOMINAL.
- 2. THE STATIONING SHOWN UNDER EACH TYPICAL IS APPROXIMATE.
- 3. 4" OF LOAM SHALL BE USED IN ALL DISTURBED AREAS.
- 4. BUTT JOINT PAYMENT SHALL BE INCIDENTAL TO ITEM 403.208 HMA 12.5MM.

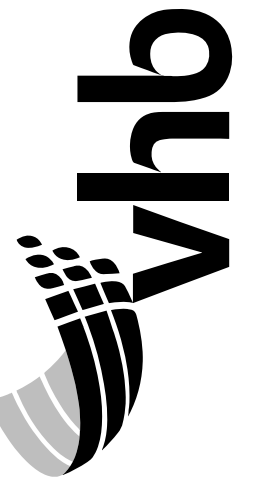

PROJ. MANAGER	B. KEEZER	BY	DATE
DESIGN-DETAILED	ECF	JRD	05/19
CHECKED-REVIEWED			
DESIGN-DETAILED			
DESIGN-DETAILED			
REVISIONS 1			
REVISIONS 2			
REVISIONS 3			
REVISIONS 4			
FIELD CHANGES			

**SIGNALIZATION OF
 CUMBERLAND MILLS ROTARY**

DETAILS (5 OF 6)

SHEET NUMBER

8

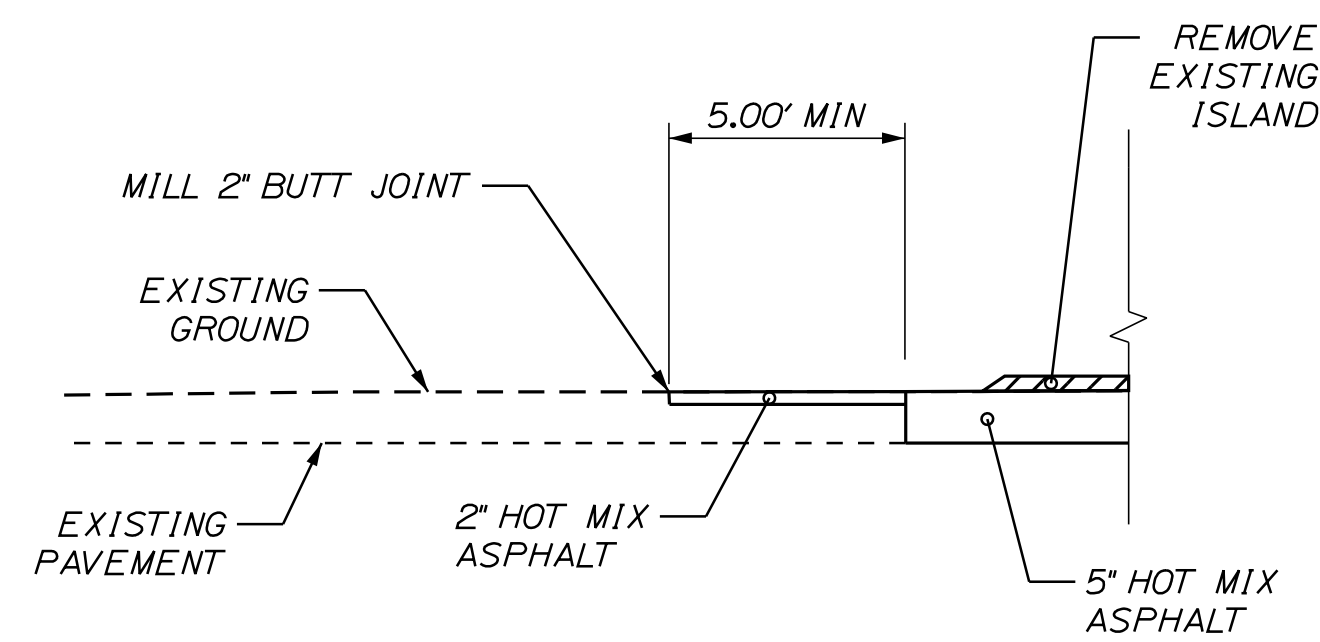
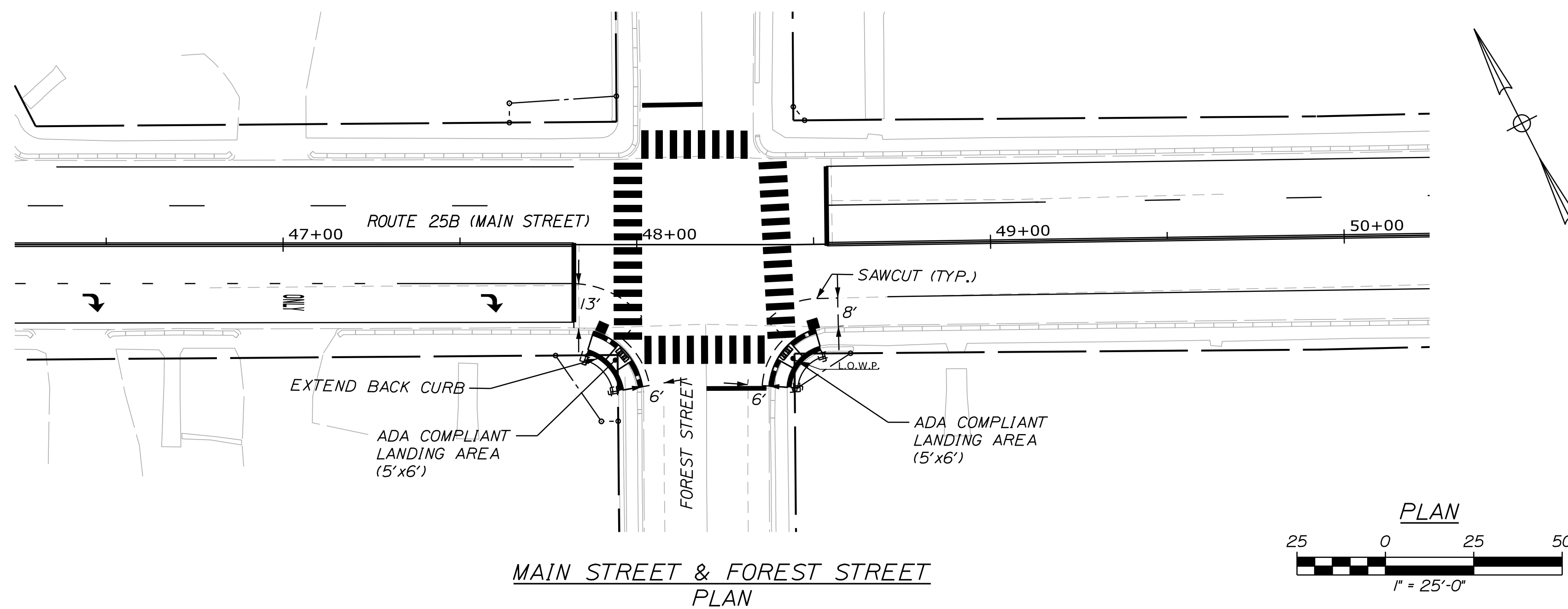

BUTT JOINT DETAIL

STA. 13+69 RT
 STA. 63+50 RT
 STA. 66+50 RT
 STA. 74+10 RT & LT
 STA. 41+55 LT
 STA. 41+80 LT
 STA. 106+85 LT
 (N.T.S.)

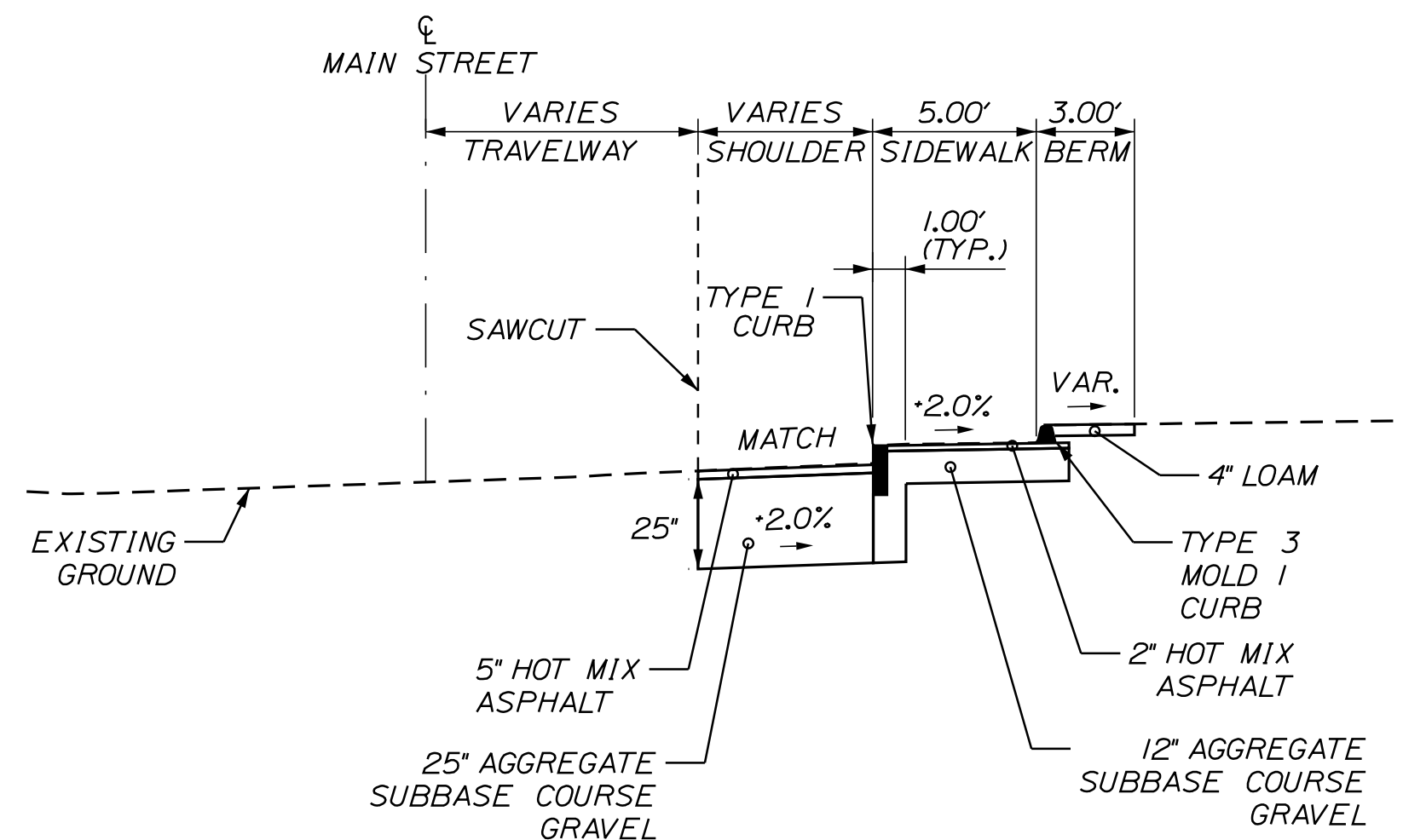

SHOULDER RECONSTRUCTION - CURB TYPE 1

STA. 47+88 TO 48+00 RT
 STA. 48+37 TO 48+50 RT
 (N.T.S.)

NOTES:

- * SEE GEOMETRIC LAYOUT SHEETS FOR PROPOSED ISLAND ELEVATIONS.
- 1. THE PAVEMENT AND BASE DEPTHS SHOWN ON THE PLANS ARE INTENDED TO BE NOMINAL.
- 2. THE STATIONING SHOWN UNDER EACH TYPICAL IS APPROXIMATE.
- 3. 4" OF LOAM SHALL BE USED IN ALL DISTURBED AREAS.
- 4. BUTT JOINT PAYMENT SHALL BE INCIDENTAL TO ITEM 403.208 HMA 12.5MM.

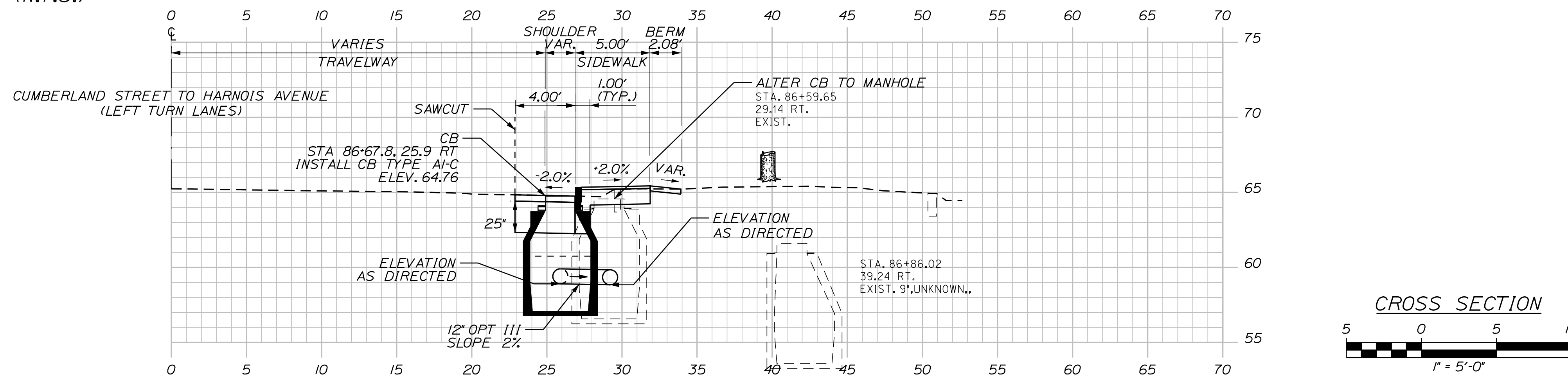

DRAINAGE DETAIL
STA. 86+67.83 RT

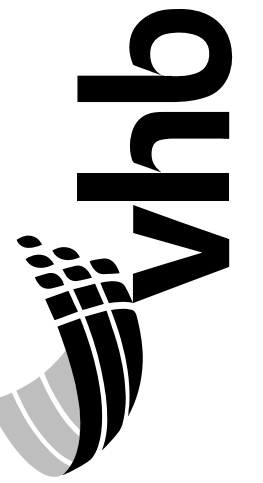
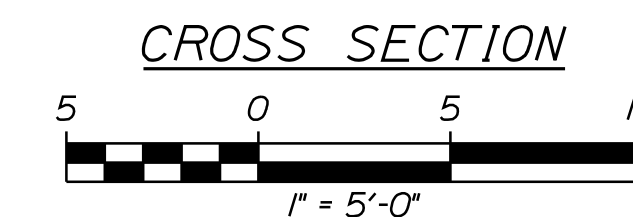

PROJ. MANAGER	B. KEEZER	BY	DATE
DESIGN-DETAILED	ECF	JRD	05/19
CHECKED-REVIEWED			
DESIGN-DETAILED			
DESIGN-DETAILED			
REVISIONS 1			
REVISIONS 2			
REVISIONS 3			
REVISIONS 4			
FIELD CHANGES			

SIGNALIZATION OF
 CUMBERLAND MILLS ROTARY
 DETAILS (6 OF 6)

SHEET NUMBER

9

MAIN STREET
 CURVE DATA #1
 PI = 31+49.69
 D = 1°08'45.7"
 Δ = 0°42'31.8" Rt.
 R = 4999.50'
 L = 61.85'
 T = 30.93'
 E = 0.10'

HARNOIS AVENUE
 CURVE DATA #1
 PI = 62+74.91
 D = 0°36'35.4" Rt.
 R = 2100.00'
 L = 174.64'
 T = 87.37'
 E = 1.82'

ITEM 604.18 - ADJUST MANHOLE OR CB TO GRADE

STATION	OFFSET	QUANTITY (EA)
74+15	8.9 LT	1.0
74+00	34.6' RT	1.0

ITEM 608.46 - REGRADING SIDEWALK

STATION	OFFSET	QUANTITY (SY)
32+90	RT	19.0
74+25	RT	15.6

ITEM 608.26 - CURB RAMP DETECTABLE WARNING FIELD

STATION	OFFSET	QUANTITY (SF)
32+90	RT	10
62+75	RT	10
62+75	LT	10
74+25	RT	10
74+25	LT	10

- NOTES:**
- ALL 609 ITEMS ARE SHOWN ON GEOMETRIC SHEETS.
 - SIDEWALKS WITHIN PROPOSED ISLAND ARE PAID FOR UNDER ITEM 304.10 AGGREGATE SUBBASE COURSE AND TYPE D AND 403.209 HMA 9.5MM.

MAIN STREET
 CURVE DATA #2
 PI = 32+83.44
 D = 34°43'29.0"
 Δ = 63°51'43.8" Rt.
 R = 165.00'
 L = 183.91'
 T = 102.83'
 E = 29.42'

HARNOIS AVENUE
 CURVE DATA #2
 PI = 63+95.50
 D = 2°43'42.1"
 Δ = 4°45'53.5" Lt.
 R = 2100.00'
 L = 174.64'
 T = 87.37'
 E = 1.82'

MAIN STREET
 CURVE DATA #3
 PI = 36+06.23
 D = 9°19'53.6"
 Δ = 21°27'44.2" Lt.
 R = 614.00'
 L = 230.00'
 T = 116.36'
 E = 10.93'

CIRCULATORY RAMP A
 CURVE DATA #1
 PI = 74+44.48
 D = 136°25'06.7"
 Δ = 112°12'53.7" Rt.
 R = 42.00'
 L = 82.26'
 T = 62.52'
 E = 33.32'

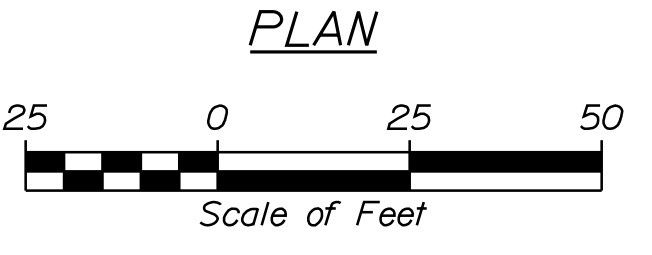
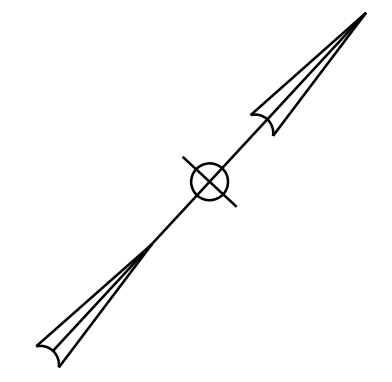
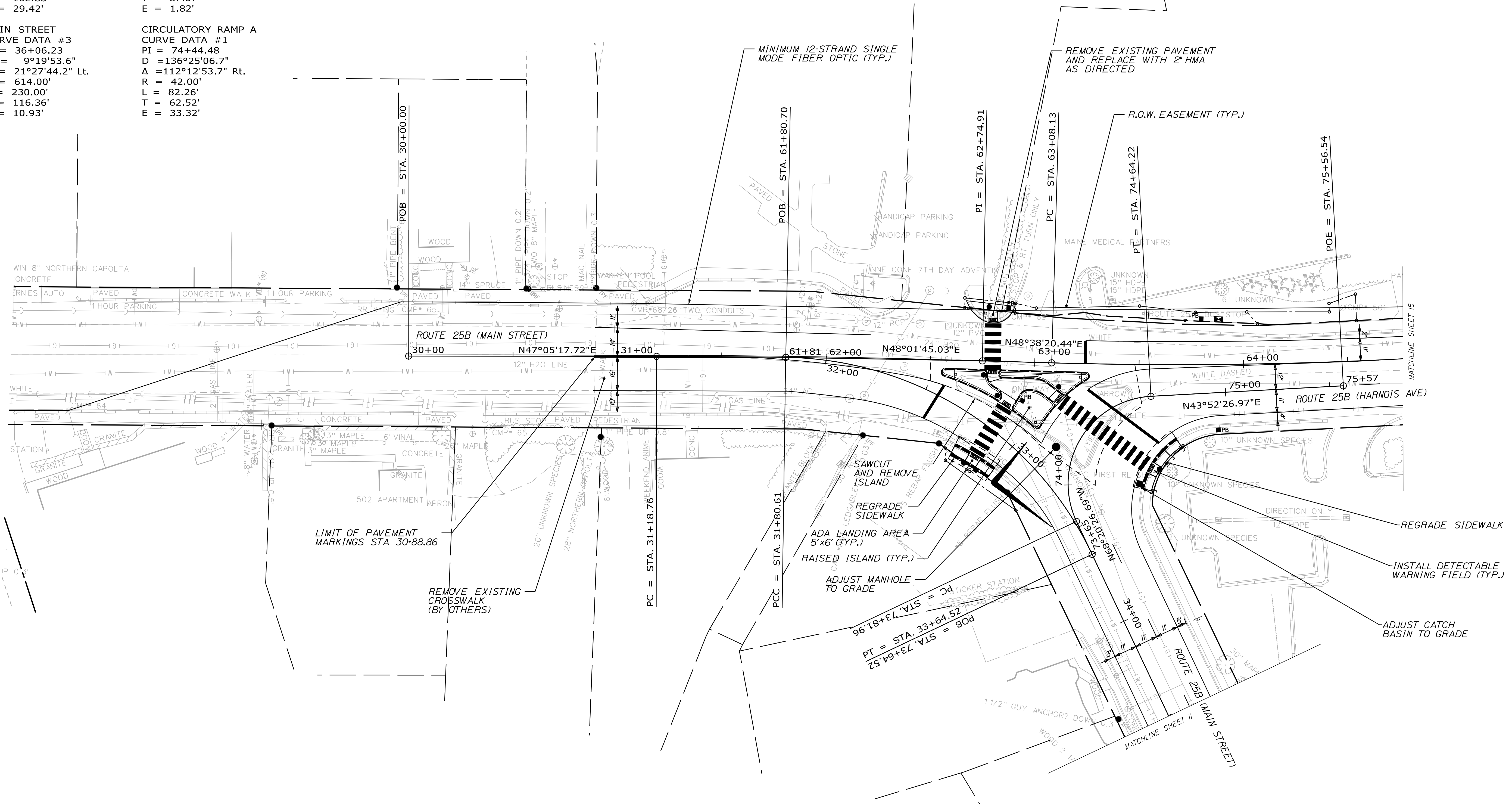

Date: 2/17/2020

Username: jrobert

Filename: ... \HIGHWAY\MSTAV010_Highway_1.dgn Division: HIGHWAY

STATE OF MAINE
 DEPARTMENT OF TRANSPORTATION
 PROJECT NO. STP-1863(700)
 WIN
 18637.00
 HIGHWAY PLANS



PROJ. MANAGER	B. KEEZER	DATE
DESIGN/REVIEWED	ECF	05/19
CHECKED/REVIEWED	JRD	
DESIGN/REVIEWED		
DESIGN/REVIEWED		
REVISIONS 1		
REVISIONS 2		
REVISIONS 3		
REVISIONS 4		
FIELD CHANGES		

SIGNALIZATION OF CUMBERLAND MILLS ROTARY
GENERAL PLANS (1 OF 6)

SHEET NUMBER
10
 OF 53

MAIN STREET
 CURVE DATA #3
 PI = 36+06.23
 D = 9°19'53.6"
 Δ = 21°27'44.2" Lt.
 R = 614.00'
 L = 230.00'
 T = 116.36'
 E = 10.93'

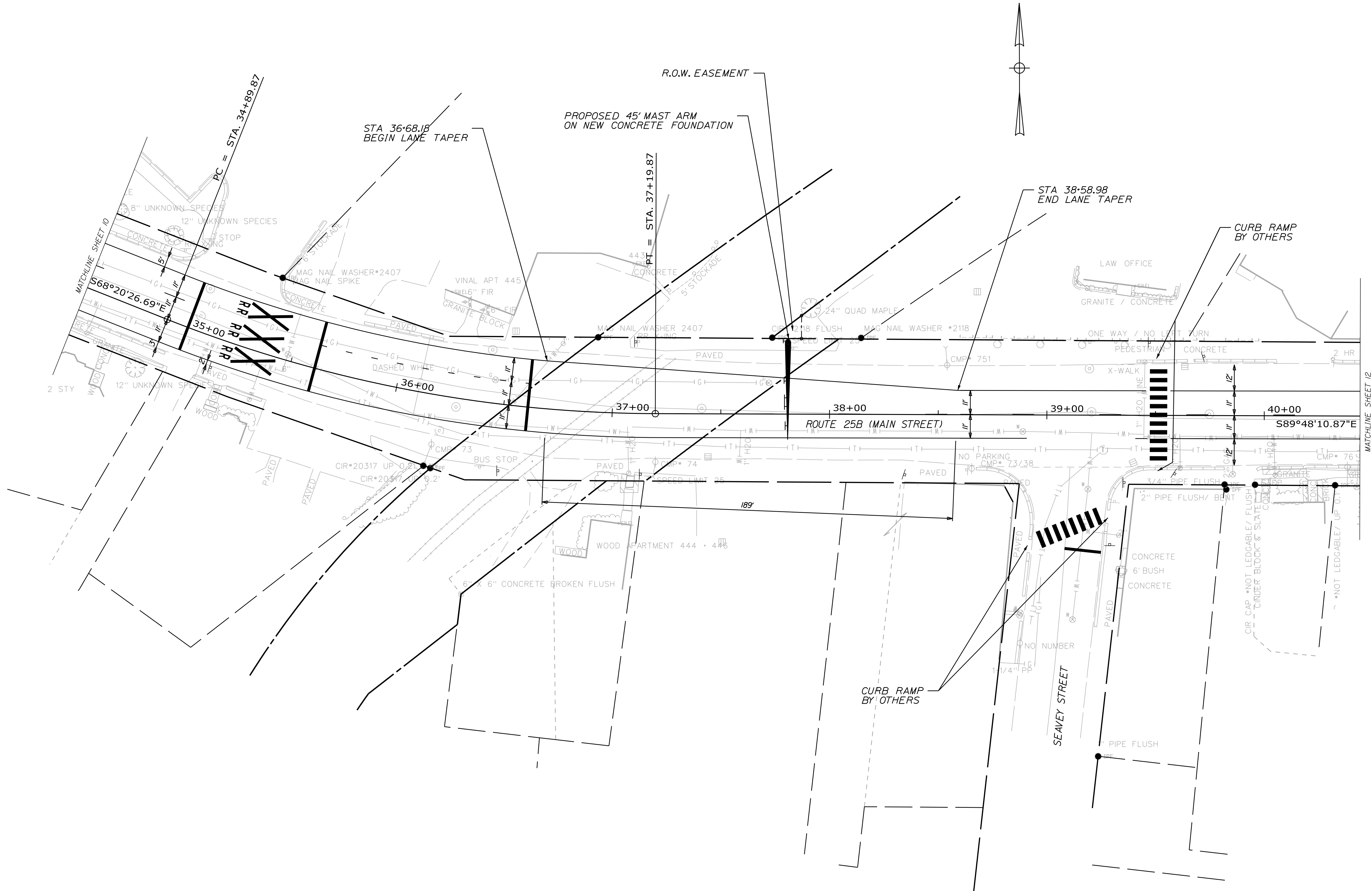
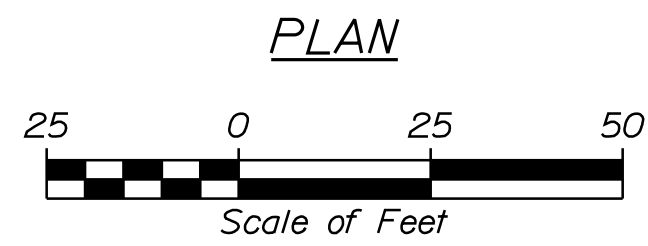

STATE OF MAINE
 DEPARTMENT OF TRANSPORTATION
 PROJECT NO. STP-1863(700)



PROJ. MANAGER	B. KEEZER	BY	DATE
DESIGN/DETAILED	ECF	JRD	05/19
CHECKED/REVIEWED			
DESIGNS/DETAILED			
DESIGNS/DETAILED			
REVISIONS 1			
REVISIONS 2			
REVISIONS 3			
REVISIONS 4			
FIELD CHANGES			

SIGNALIZATION OF
 CUMBERLAND MILLS ROTARY
 GENERAL PLANS (2 OF 6)

SHEET NUMBER
11
 OF 53

WIN
 18637.00
 HIGHWAY PLANS

Date: 2/17/2020

Username: jrobert

Division: HIGHWAY

Filename: ... \HIGHWAY\MSTAV012_Highway_3.dgn

MAIN STREET
 CURVE DATA #4
 PI = 43+65.36
 D = 9°47'38.9"
 Δ = 26°27'04.5" Rt.
 R = 585.00'
 L = 270.07'
 T = 137.49'
 E = 15.94'

CUMBERLAND STREET
 CURVE DATA #2
 PI = 21+77.91
 D = 14°43'44.4"
 Δ = 19°16'52.9" Lt.
 R = 389.00'
 L = 130.91'
 T = 66.08'
 E = 5.57'

CUMBERLAND STREET
 CURVE DATA #3
 PI = 23+81.48
 D = 13°56'26.1"
 Δ = 14°11'43.5" Rt.
 R = 411.00'
 L = 101.83'
 T = 51.18'
 E = 3.17'

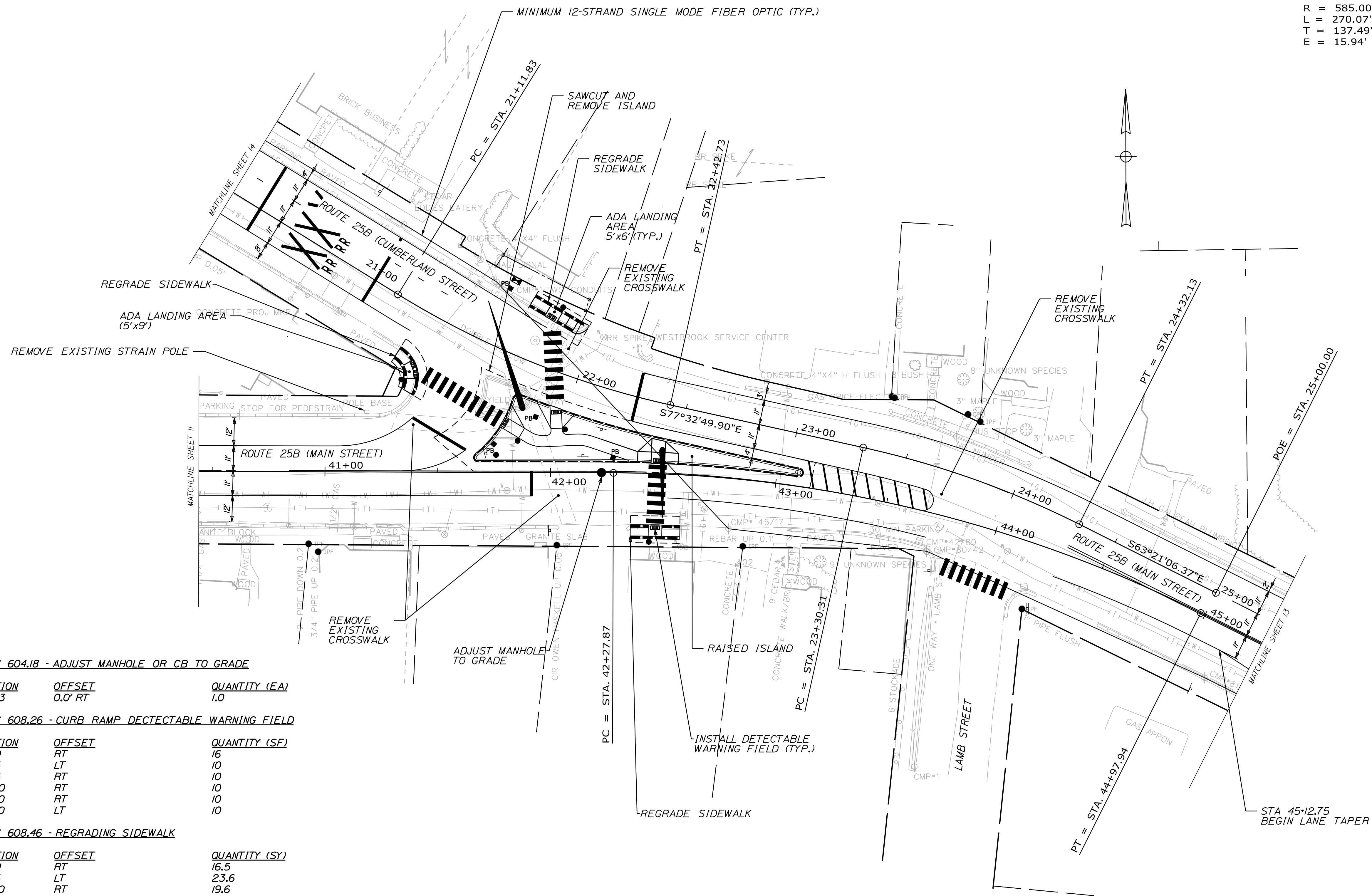

ITEM 604.18 - ADJUST MANHOLE OR CB TO GRADE

STATION	OFFSET	QUANTITY (EA)
42+23	0.0' RT	1.0

ITEM 608.26 - CURB RAMP DETECTABLE WARNING FIELD

STATION	OFFSET	QUANTITY (SF)
21+40	RT	16
21+75	LT	10
21+75	RT	10
22+00	RT	10
42+50	RT	10
42+50	LT	10

ITEM 608.46 - REGRADING SIDEWALK

STATION	OFFSET	QUANTITY (SY)
21+40	RT	16.5
21+75	LT	23.6
42+50	RT	19.6

- NOTES:**
- ALL 609 ITEMS ARE SHOWN ON GEOMETRIC SHEETS.
 - SIDEWALKS WITHIN PROPOSED ISLAND ARE PAID FOR UNDER ITEM 304.10 AGGREGATE SUBBASE COURSE AND TYPE D AND 403.209 HMA 9.5MM.

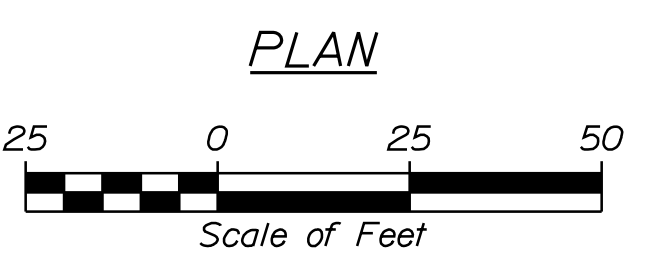

STATE OF MAINE
 DEPARTMENT OF TRANSPORTATION
 PROJECT NO. STP-1863(700)
 WIN
 18637.00
 HIGHWAY PLANS



PROJ. MANAGER	B. KEEZER	BY	DATE
DESIGNED/TAILED	ECF		05/19
CHECKED/REVIEWED			
DESIGNED/TAILED			
DESIGNED/TAILED			
REVISIONS 1			
REVISIONS 2			
REVISIONS 3			
REVISIONS 4			
FIELD CHANGES			

SIGNALIZATION OF
 CUMBERLAND MILLS ROTARY
 GENERAL PLANS (3 OF 6)

SHEET NUMBER
 12
 OF 53

Date: 2/17/2020

Username: jrobert

Filename: ... \HIGHWAY\MSTAN013_Highway_4.dgn Division: HIGHWAY

ITEM 604.18 - ADJUST MANHOLE OR CB TO GRADE

STATION	OFFSET	QUANTITY (EA)
47+90	24.2' RT	1.0
48+50	23.1' RT	1.0

ITEM 608.26 - CURB RAMP DETECTABLE WARNING FIELD

STATION	OFFSET	QUANTITY (SF)
47+90	RT	10
48+40	RT	10

ITEM 608.46 - REGRADING SIDEWALK

STATION	OFFSET	QUANTITY (SY)
47+90	RT	11.6
48+40	RT	10.7

NOTES:

- ALL 609 ITEMS ARE SHOWN ON GEOMETRIC SHEETS.
- SIDEWALKS WITHIN PROPOSED ISLAND ARE PAID FOR UNDER ITEM 304.10 AGGREGATE SUBBASE COURSE AND TYPE D AND 403.209 HMA 9.5MM.

MAIN STREET
 CURVE DATA #5
 PI = 48+44.64
 $\Delta = 0^\circ 51' 04.3''$ Lt.

MAIN STREET
 CURVE DATA #6
 PI = 51+06.87
 $\Delta = 0^\circ 40' 10.7''$ Lt.

STATE OF MAINE
 DEPARTMENT OF TRANSPORTATION
 PROJECT NO. STP-1863(700)
 WIN
 18637.00
 HIGHWAY PLANS

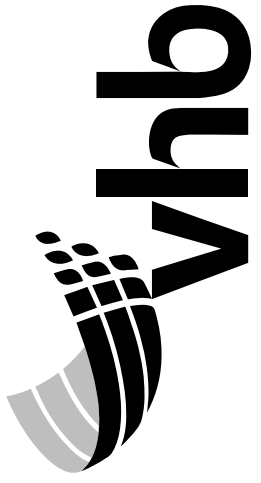

PROJ. MANAGER	B. KEIZER	DATE
DESIGN-DETAILED	ECF	05/18
CHECKED-REVIEWED	ECF	
DESIGN-DETAILED		
DESIGN-DETAILED		
REVISIONS 1		
REVISIONS 2		
REVISIONS 3		
REVISIONS 4		
FIELD CHANGES		

SIGNALIZATION OF
 CUMBERLAND MILLS ROTARY
 GENERAL PLANS (4 OF 6)

SHEET NUMBER
 13
 OF 53

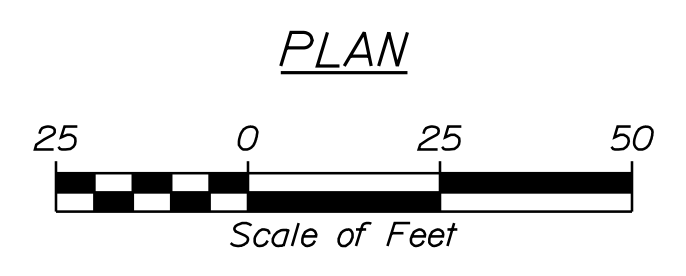
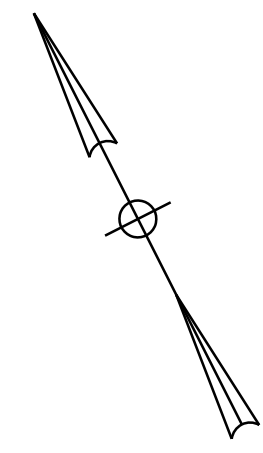
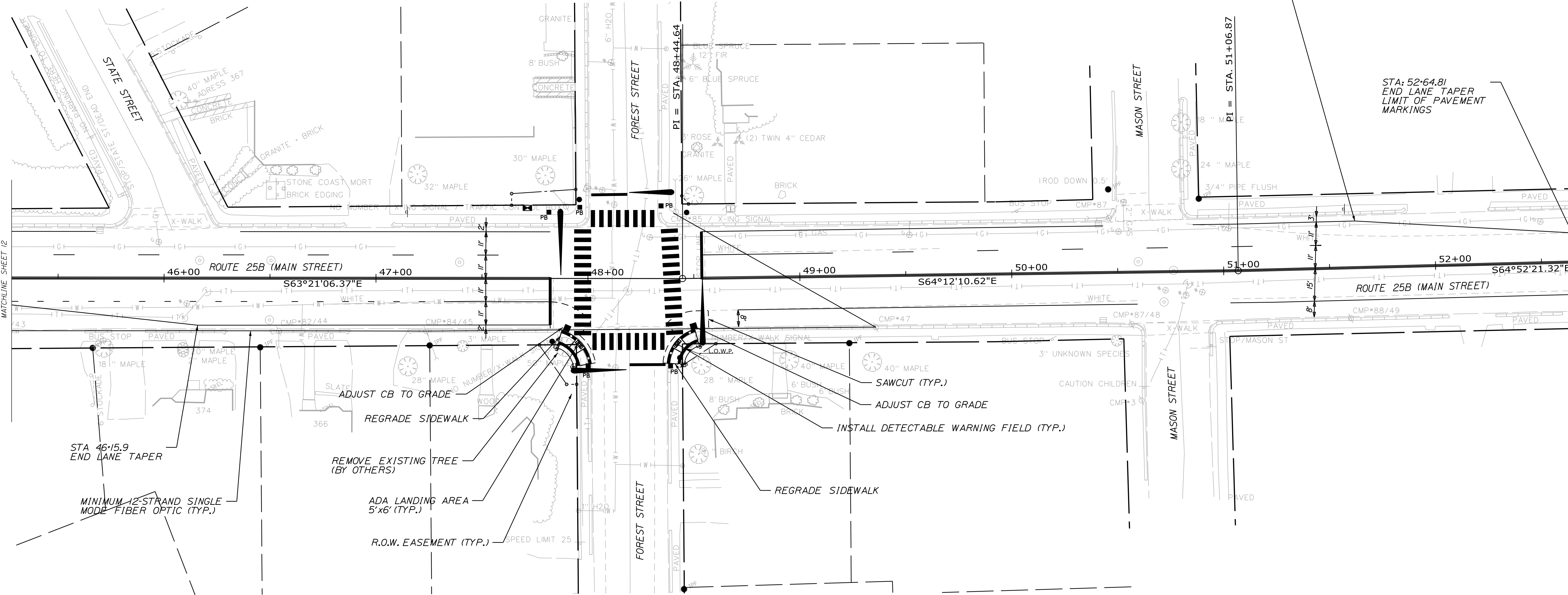

CIRCULATORY RAMP B
 CURVE DATA #1
 PI = 86+90.68
 D = 63°39'43.1"
 Δ = 78°18'48.0" Rt.
 R = 90.00'
 L = 123.01'
 T = 73.29'
 E = 26.07'

CUMBERLAND ENTRANCE RAMP
 CURVE DATA #2
 PI = 66+90.67
 D = 95°29'34.7"
 Δ = 101°41'12.0" Lt.
 R = 60.00'
 L = 106.49'
 T = 73.68'
 E = 35.02'

REMOVE THE FOLLOWING DRIVES AND ENTRANCES

STATION	OFFSET	TYPE	OPENING WIDTH
15-75	RT	PAVED	28.7'

ITEM 603.159 - 12" OPT III

STATION	OFFSET	QUANTITY (LF)
86-59	29.7' RT	8.0

ITEM 604.072 - CATCH BASIN TYPE AI-C

STATION	OFFSET	QUANTITY (EA)
86-68	25.9' RT	1.0

ITEM 604.16 - ALTER CATCH BASIN TO MANHOLE

STATION	OFFSET	QUANTITY (EA)
86-59	29.7' RT	1.0

ITEM 604.18 - ADJUST MANHOLE OR CB TO GRADE

STATION	OFFSET	QUANTITY (EA)
14-49	8.5' RT	1.0
14-52	21.9' LT	1.0
14-66	3.3' RT	1.0
66-66	11.8' RT	1.0
87-02	21.2' RT	1.0

CUMBERLAND STREET
 CURVE DATA #1
 PI = 11+76.23
 D = 5°43'46.5"
 Δ = 11°29'26.8" Rt.
 R = 1000.00'
 L = 200.55'
 T = 100.61'
 E = 5.05'

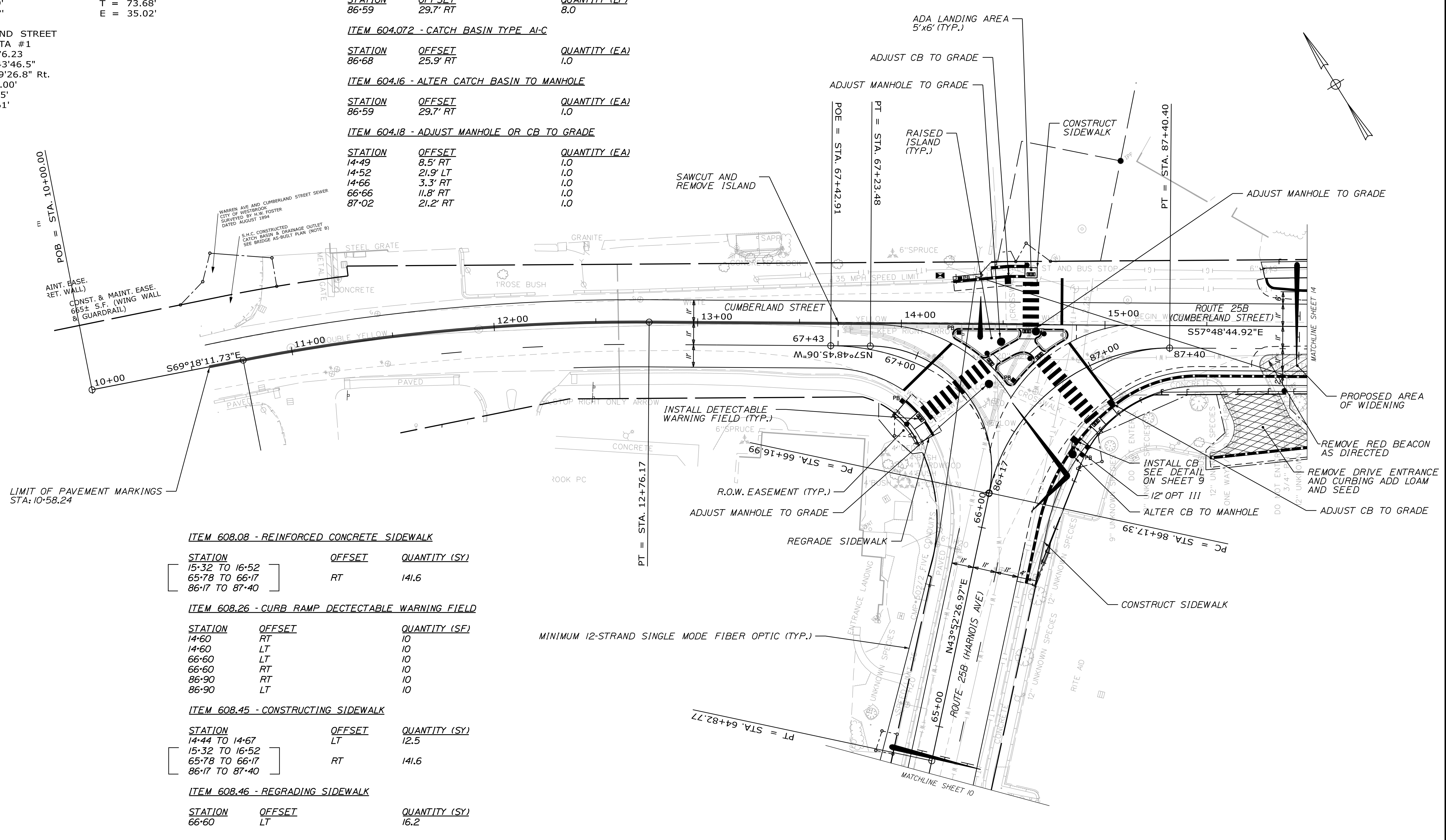

ITEM 608.08 - REINFORCED CONCRETE SIDEWALK

STATION	OFFSET	QUANTITY (SY)
15-32 TO 16-52	RT	141.6
65-78 TO 66-17		
86-17 TO 87-40		

ITEM 608.26 - CURB RAMP DETECTABLE WARNING FIELD

STATION	OFFSET	QUANTITY (SF)
14-60	RT	10
14-60	LT	10
66-60	LT	10
66-60	RT	10
86-90	RT	10
86-90	LT	10

ITEM 608.45 - CONSTRUCTING SIDEWALK

STATION	OFFSET	QUANTITY (SY)
14-44 TO 14-67	LT	12.5
15-32 TO 16-52	RT	141.6
65-78 TO 66-17		
86-17 TO 87-40		

ITEM 608.46 - REGRADING SIDEWALK

STATION	OFFSET	QUANTITY (SY)
66-60	LT	16.2

- NOTES:**
- ALL 609 ITEMS ARE SHOWN ON GEOMETRIC SHEETS.
 - SIDEWALKS WITHIN PROPOSED ISLAND ARE PAID FOR UNDER ITEM 304.10 AGGREGATE SUBBASE COURSE AND TYPE D AND 403.209 HMA 9.5MM.

PLAN

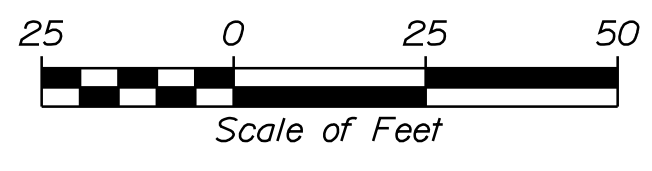

Date: 2/17/2020

Username: jrobert

Filename: ... \HIGHWAY\MST\A015_Highway_6.dgn Division: HIGHWAY

STATE OF MAINE
 DEPARTMENT OF TRANSPORTATION
 PROJECT NO. STP-1863(700)
 WIN
 18637.00
 HIGHWAY PLANS



PROJ. MANAGER	B. KEEZER	DATE	05/19
CHECKED-REVIEWED	ECF		
DESIGN-DETAILED			
DESIGN-REVIEWED			
DESIGN-DETAILED			
REVISIONS 1			
REVISIONS 2			
REVISIONS 3			
REVISIONS 4			
FIELD CHANGES			

SIGNALIZATION OF
 CUMBERLAND MILLS ROTARY
 GENERAL PLANS (6 OF 6)

SHEET NUMBER

15

OF 53

CONTROL POINTS - PROPOSED ISLAND					
POINT	STATION	OFFSET	X CORD.	Y CORD.	ELEV.
1	62+75.54	4.00 RT	990635.12	309174.46	59.85
2	62+57.24	3.81 RT	990621.42	309162.39	59.80
3	32+54.98	9.38 LT	990623.56	309159.06	60.02
4	32+80.44	12.38 LT	990649.46	309167.60	60.10
5	32+81.77	15.68 LT	990650.48	309171.06	60.16
6	62+81.73	12.41 RT	990645.32	309172.23	60.16
7	62+77.61	6.16 RT	990638.10	309174.19	59.89
8	62+84.55	3.98 RT	990641.86	309180.42	59.84
9	63+24.39	3.88 RT	990671.69	309206.89	60.15
10	74+42.15	17.43 LT	990675.20	309204.72	60.21
11	74+33.66	18.09 LT	990672.88	309192.87	60.06
12	74+32.43	19.88 LT	990671.05	309191.12	60.07
13	63+06.54	10.30 RT	990662.55	309190.21	60.12
14	62+99.18	7.97 RT	990655.48	309187.09	60.07
15	62+84.56	8.06 RT	990644.57	309177.36	59.94
16	32+90.02	13.15 LT	990659.65	309169.42	60.10
17	33+01.55	13.65 LT	990672.09	309170.40	60.04
18	74+19.77	19.45 LT	990674.09	309172.85	59.87
19	74+27.58	18.66 LT	990672.61	309184.11	59.95
20	74+29.01	20.73 RT	990670.36	309186.02	60.01
21	63+04.88	15.25 RT	990664.62	309185.41	60.06
22	62+97.64	12.97 RT	990657.03	309182.32	60.01
23	62+93.32	15.47 RT	990656.05	309177.59	60.10
32	32+88.07	14.93 LT	990657.41	309171.03	60.14

CONTROL POINTS				
POINT	STATION	OFFSET	X CORD.	Y CORD.
24	32+76.60	15.72 LT	990649.72	309139.24
24A	32+77.38	20.67 RT	990651.15	309134.45
25	32+85.30	14.67 LT	990657.42	309141.30
26	32+91.95	13.90 LT	990663.40	309142.56
27A	33+01.14	17.93 RT	990671.07	309138.72
27	33+00.50	12.97 LT	990671.22	309143.78
28	73+87.58	34.75 RT	990729.38	309184.26
29	74+37.72	35.06 RT	990726.05	309191.51
30	74+60.71	31.24 RT	990724.52	309197.40
31	74+68.56	25.30 RT	990723.89	309205.28
31A	74+74.97	20.56 RT	990724.92	309213.19

ITEM 609.11 - VERTICAL CURB TYPE 1		
PT. TO PT.	RADIUS	LENGTH
24A TO 27A	126.67'	21.2'

ITEM 609.12 - VERTICAL CURB TYPE 1 - CIRCULAR		
PT. TO PT.	RADIUS	LENGTH
31 TO 31A	36.21'	8.0'

ITEM 609.238 - TERMINAL CURB TYPE 1 - 8FOOT		
PT. TO PT.	RADIUS	LENGTH
24 TO 25	-	8.0'
26 TO 27	-	8.0'

ITEM 609.2381 - TERMINAL CURB TYPE 1 - 8FOOT - CIRCULAR		
PT. TO PT.	RADIUS	LENGTH
28 TO 29	40.11'	8.0'
30 TO 31	40.11'	8.0'

ITEM 609.34 - CURB TYPE 5		
PT. TO PT.	RADIUS	LENGTH
1 TO 2	-	18.3'
3 TO 4	125.00'	27.3'
8 TO 9	-	39.9'
10 TO 11	64.85'	12.1'
12 TO 13	-	8.5'
14 TO 15	-	14.7'
16 TO 17	125.00'	12.5'
18 TO 19	64.85'	11.4'
20 TO 21	-	5.8'
23 TO 32	-	6.7'

ITEM 609.35 - CURB TYPE 5 - CIRCULAR		
PT. TO PT.	RADIUS	LENGTH
2 TO 3	2.00'	5.7'
4 TO 5	2.00'	4.3'
5 TO 6	5.00'	5.5'
6 TO 7	7.00'	8.0'
7 TO 1	2.00'	3.1'
9 TO 10	2.00'	5.2'
11 TO 12	2.00'	2.7'
13 TO 14	12.50'	7.7'
15 TO 8	2.00'	6.2'
17 TO 18	2.00'	3.5'
19 TO 20	2.00'	3.3'
21 TO 22	7.50'	7.8'
22 TO 23	5.00'	5.3'
32 TO 16	2.00'	3.0'

SUMMARY				
	TYPE 5	TYPE 5 CIRCULAR	TYPE 1	RADIUS
SUBTOTAL	434	58	370	125
% BREAKAGE OR UNUSABLE	25%	25%	25%	75%
TOTAL CURB FOR RESET	325	43	278	31
TOTAL PROPOSED CURB	622	215	378	0
ESTIMATED REMOVE & RESET QUANTITY	325	43	278	0
SURPLUS	-	-	-	31
ESTIMATED NEW INSTALL QUANTITY	297	172	100	-

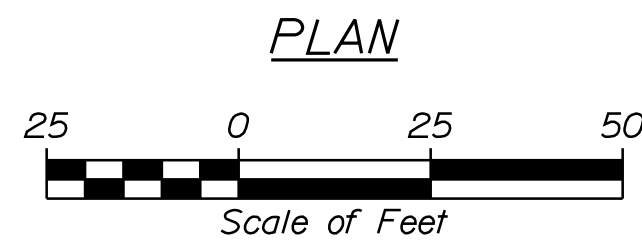
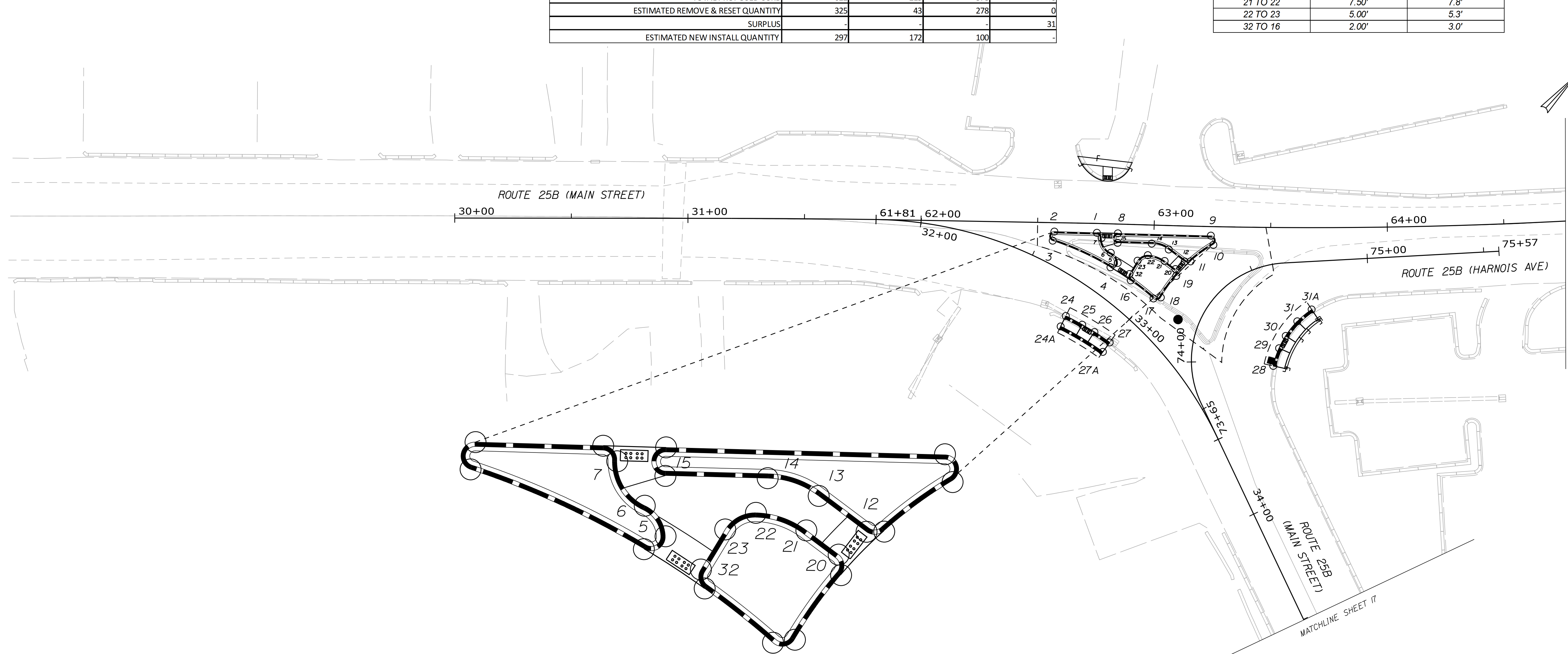

PROJ. MANAGER	B. KEEZER	BY	DATE
DESIGN-DETAILED	ECF	JRD	05/19
CHECKED-REVIEWED			
DESIGN-DETAILED			
DESIGN-DETAILED			
REVISIONS 1			
REVISIONS 2			
REVISIONS 3			
REVISIONS 4			
FIELD CHANGES			

SIGNALIZATION OF
CUMBERLAND MILLS ROTARY
GEOMETRIC LAYOUT (1 OF 4)

Date: 2/17/2020

Username: jrobert

Division: HIGHWAY

Filename: ... \MSTA\017_Geol.yout_2.dgn

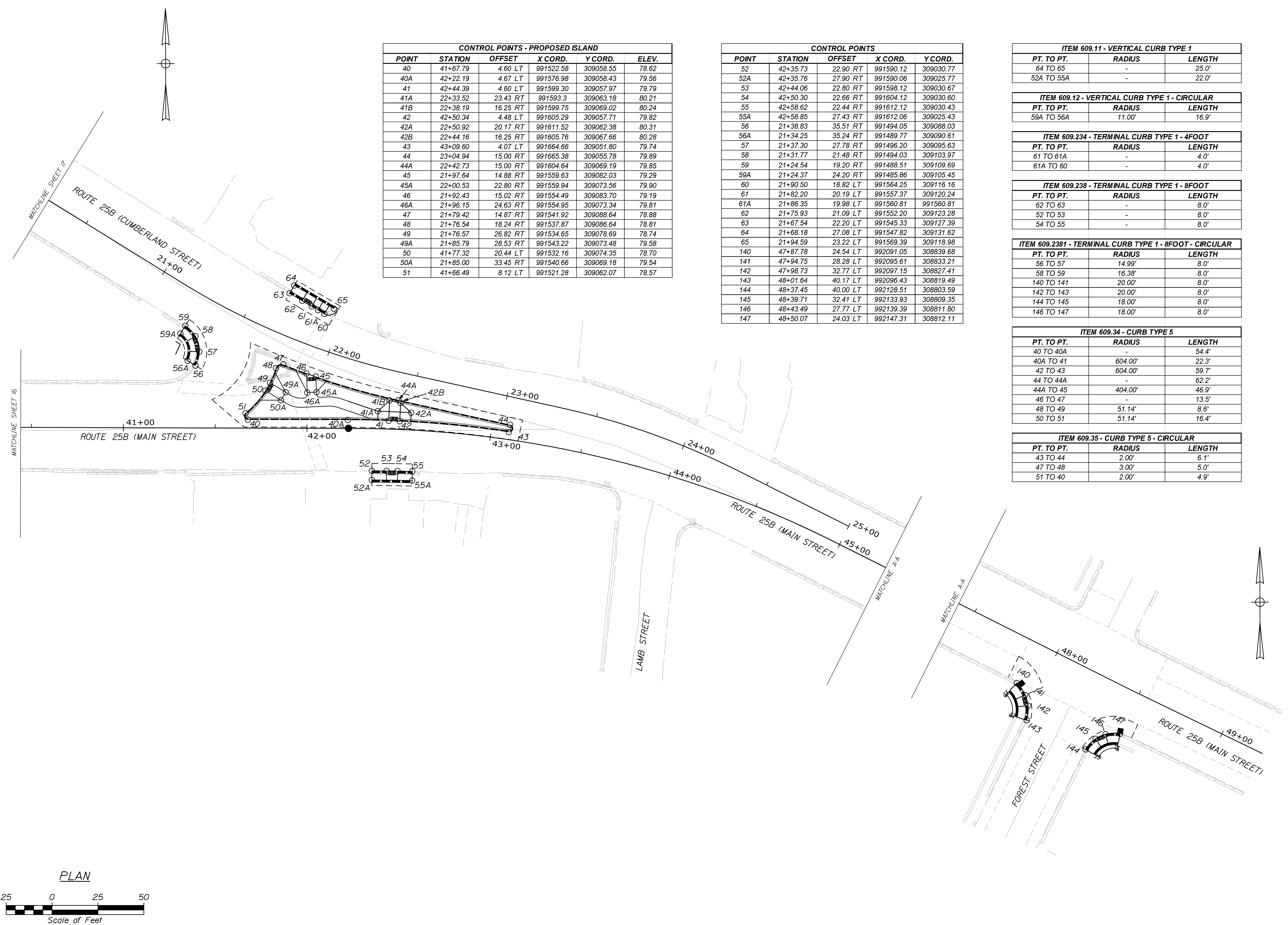

CONTROL POINTS - PROPOSED ISLAND					
POINT	STATION	OFFSET	X CORD.	Y CORD.	ELEV.
40	41+67.79	4.60 LT	991522.58	309058.55	78.62
40A	42+22.19	4.67 LT	991576.98	309058.43	79.56
41	42+44.39	4.60 LT	991599.30	309057.97	79.79
41A	22+33.52	23.43 RT	991593.3	309063.18	80.21
41B	22+38.19	16.25 RT	991599.75	309069.02	80.24
42	42+50.34	4.48 LT	991605.29	309057.71	79.82
42A	22+50.92	20.17 RT	991611.52	309062.38	80.31
42B	22+44.16	16.25 RT	991605.76	309067.66	80.28
43	43+09.60	4.07 LT	991664.66	309051.80	79.74
44	23+04.94	15.00 RT	991665.38	309055.78	79.89
44A	22+42.73	15.00 RT	991604.64	309069.19	79.85
45	21+97.64	14.88 RT	991559.63	309082.03	79.29
45A	22+00.53	22.80 RT	991559.94	309073.56	79.90
46	21+92.43	15.02 RT	991554.49	309083.70	79.19
46A	21+96.15	24.63 RT	991554.95	309073.34	79.81
47	21+79.42	14.87 RT	991541.92	309088.64	78.88
48	21+76.54	18.24 RT	991537.87	309086.64	78.81
49	21+76.57	26.82 RT	991534.65	309078.69	78.74
49A	21+85.79	28.53 RT	991543.22	309073.48	79.58
50	41+77.32	20.44 LT	991532.16	309074.35	78.70
50A	21+85.00	33.45 RT	991540.66	309069.18	79.54
51	41+66.49	8.12 LT	991521.28	309062.07	78.57

CONTROL POINTS					
POINT	STATION	OFFSET	X CORD.	Y CORD.	
52	42+35.73	22.90 RT	991590.12	309030.77	
52A	42+35.76	27.90 RT	991590.06	309025.77	
53	42+44.06	22.80 RT	991598.12	309030.67	
54	42+50.30	22.66 RT	991604.12	309030.60	
55	42+58.62	22.44 RT	991612.12	309030.43	
55A	42+58.85	27.43 RT	991612.06	309025.43	
56	21+38.83	35.51 RT	991494.05	309088.03	
56A	21+34.25	35.24 RT	991489.77	309090.61	
57	21+37.30	27.78 RT	991496.20	309095.63	
58	21+31.77	21.48 RT	991494.03	309103.97	
59	21+24.54	19.20 RT	991488.51	309109.69	
59A	21+24.37	24.20 RT	991485.86	309105.45	
60	21+90.50	18.82 LT	991564.25	309116.16	
61	21+82.20	20.19 LT	991557.37	309120.24	
61A	21+86.35	19.98 LT	991560.81	991560.81	
62	21+75.93	21.09 LT	991552.20	309123.28	
63	21+67.54	22.20 LT	991545.33	309127.39	
64	21+68.18	27.08 LT	991547.82	309131.62	
65	21+94.59	23.22 LT	991569.39	309118.98	
140	47+87.78	24.54 LT	992091.05	308839.68	
141	47+94.75	28.28 LT	992095.61	308833.21	
142	47+98.73	32.77 LT	992097.15	308827.41	
143	48+01.64	40.17 LT	992096.43	308819.49	
144	48+37.45	40.00 LT	992128.51	308803.59	
145	48+39.71	32.41 LT	992133.93	308809.35	
146	48+43.49	27.77 LT	992139.39	308811.80	
147	48+50.07	24.03 LT	992147.31	308812.11	

ITEM 609.11 - VERTICAL CURB TYPE 1		
PT. TO PT.	RADIUS	LENGTH
64 TO 65	-	25.0'
52A TO 55A	-	22.0'

ITEM 609.12 - VERTICAL CURB TYPE 1 - CIRCULAR		
PT. TO PT.	RADIUS	LENGTH
59A TO 56A	11.00'	16.9'

ITEM 609.234 - TERMINAL CURB TYPE 1 - 4FOOT		
PT. TO PT.	RADIUS	LENGTH
61 TO 61A	-	4.0'
61A TO 60	-	4.0'

ITEM 609.238 - TERMINAL CURB TYPE 1 - 8FOOT		
PT. TO PT.	RADIUS	LENGTH
62 TO 63	-	8.0'
52 TO 53	-	8.0'
54 TO 55	-	8.0'

ITEM 609.2381 - TERMINAL CURB TYPE 1 - 8FOOT - CIRCULAR		
PT. TO PT.	RADIUS	LENGTH
56 TO 57	14.99'	8.0'
58 TO 59	16.38'	8.0'
140 TO 141	20.00'	8.0'
142 TO 143	20.00'	8.0'
144 TO 145	18.00'	8.0'
146 TO 147	18.00'	8.0'

ITEM 609.34 - CURB TYPE 5		
PT. TO PT.	RADIUS	LENGTH
40 TO 40A	-	54.4'
40A TO 41	604.00'	22.3'
42 TO 43	604.00'	59.7'
44 TO 44A	-	62.2'
44A TO 45	404.00'	46.9'
46 TO 47	-	13.5'
48 TO 49	51.14'	8.6'
50 TO 51	51.14'	16.4'

ITEM 609.35 - CURB TYPE 5 - CIRCULAR		
PT. TO PT.	RADIUS	LENGTH
43 TO 44	2.00'	6.1'
47 TO 48	3.00'	5.0'
51 TO 40	2.00'	4.9'

STATE OF MAINE
DEPARTMENT OF TRANSPORTATION
PROJECT NO. STP-1863(700)
WIN
18637.00
HIGHWAY PLANS



PROJ. MANAGER	B. KEEZER	DATE
DESIGN-DETAILED	ECF	05/18
CHECKED-REVIEWED	ECF	
DESIGN-DETAILED		
DESIGN-DETAILED		
REVISIONS 1		
REVISIONS 2		
REVISIONS 3		
REVISIONS 4		
FIELD CHANGES		

SIGNALIZATION OF
CUMBERLAND MILLS ROTARY
GEOMETRIC LAYOUT (2 OF 4)

SHEET NUMBER
17
OF 53

CONTROL POINTS - PROPOSED ISLAND					
POINT	STATION	OFFSET	X CORD.	Y CORD.	ELEV.
70	17+19.98	14.85 LT	991162.20	309352.18	68.55
71	17+27.78	14.88 LT	991168.83	309348.05	68.65
72	17+30.77	17.92 LT	991172.98	309349.03	68.75
73	17+30.80	21.36 LT	991174.83	309351.92	68.82
74	97+22.79	22.46 RT	991175.22	309356.45	68.67
75	97+22.73	19.09 RT	991173.99	309359.59	68.42
76	97+19.78	16.28 RT	991169.78	309361.09	68.34
77	97+13.22	17.71 RT	991162.83	309357.52	68.36
78	97+26.89	17.53 RT	991178.00	309362.84	68.43
79	97+26.87	22.26 RT	991179.80	309358.47	68.55
80	107+31.70	25.77 LT	991182.73	309356.61	68.59
81	107+31.79	22.02 LT	991186.48	309356.85	68.59
82	107+33.78	19.14 LT	991189.31	309359.44	68.54
83	107+40.77	17.15 LT	991191.65	309368.02	68.57
84	97+37.27	13.55 RT	991187.10	309371.61	68.35
85	97+29.11	14.63 RT	991179.21	309366.52	68.38
86	17+35.77	22.40 LT	991179.60	309350.16	68.79
87	17+35.77	18.01 LT	991177.26	309346.44	68.81
88	17+38.73	15.00 LT	991178.16	309342.31	68.79
89	17+46.81	15.00 LT	991184.99	309338.01	68.89
90	107+19.35	20.67 LT	991189.64	309341.15	68.50
91	107+25.51	20.44 LT	991188.64	309348.94	68.51
92	107+27.94	23.42 LT	991185.36	309351.77	68.59
93	107+27.99	26.84 LT	991181.95	309351.55	68.66

CONTROL POINTS				
POINT	STATION	OFFSET	X CORD.	Y CORD.
94	16+51.57	22.95 RT	991084.17	309356.63
95	16+43.73	23.32 RT	991077.34	309360.49
95A	16+29.27	24.00 RT	991064.75	309367.62
96	16+07.62	59.21 RT	991027.66	309349.35

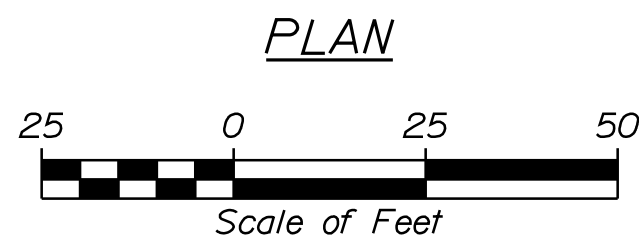
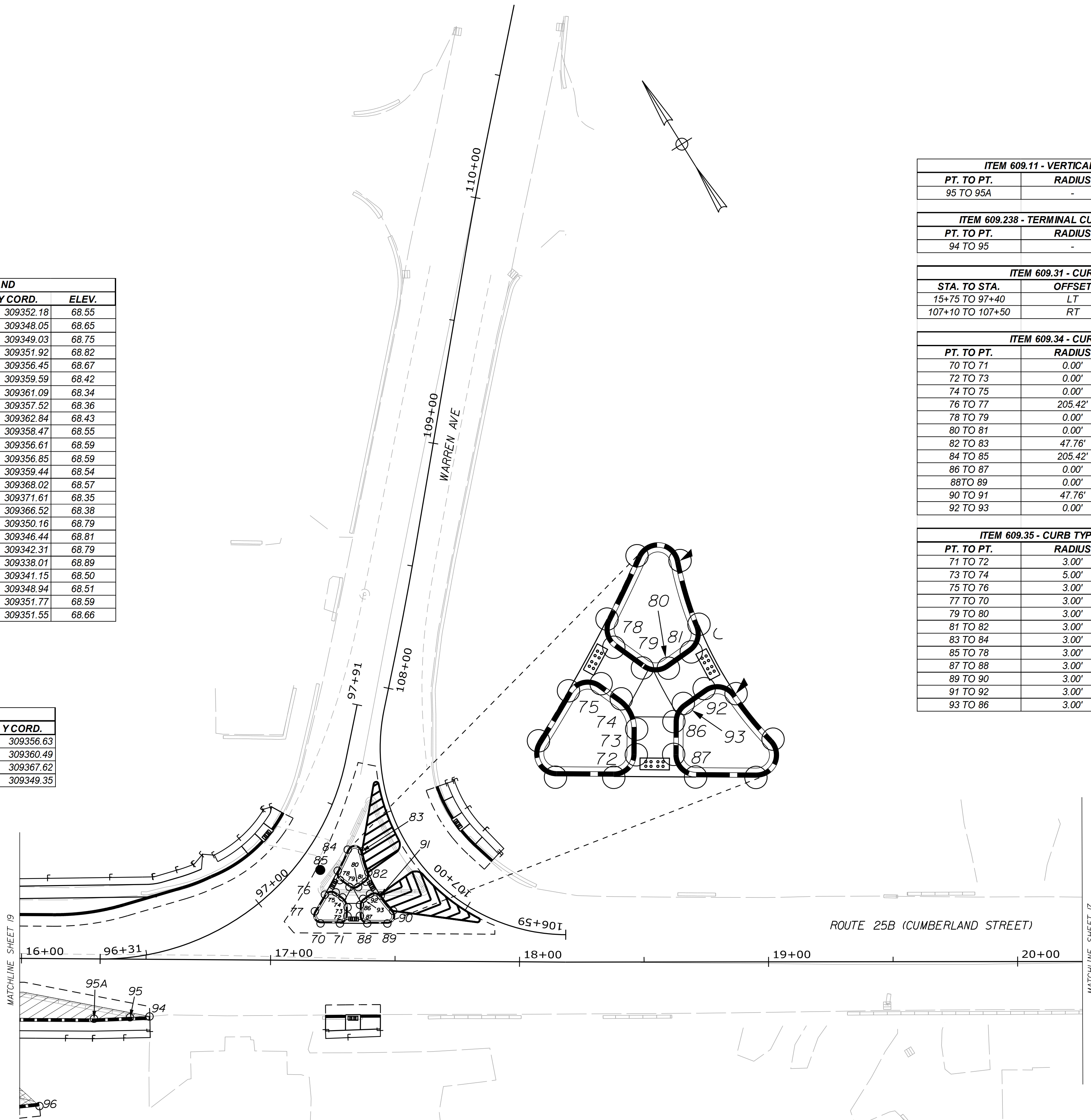

ITEM 609.11 - VERTICAL CURB TYPE 1		
PT. TO PT.	RADIUS	LENGTH
95 TO 95A	-	14.56

ITEM 609.238 - TERMINAL CURB TYPE 1 - 8FOOT		
PT. TO PT.	RADIUS	LENGTH
94 TO 95	-	8.0'

ITEM 609.31 - CURB TYPE 3		
STA. TO STA.	OFFSET	LENGTH
15+75 TO 97+40	LT	137.0
107+10 TO 107+50	RT	31.9

ITEM 609.34 - CURB TYPE 5		
PT. TO PT.	RADIUS	LENGTH
70 TO 71	0.00'	7.6'
72 TO 73	0.00'	3.4'
74 TO 75	0.00'	3.3'
76 TO 77	205.42'	7.9'
78 TO 79	0.00'	3.3'
80 TO 81	0.00'	3.7'
82 TO 83	47.76'	9.0'
84 TO 85	205.42'	9.4'
86 TO 87	0.00'	3.4'
88 TO 89	0.00'	8.1'
90 TO 91	47.76'	7.8'
92 TO 93	0.00'	3.4'

ITEM 609.35 - CURB TYPE 5 - CIRCULAR		
PT. TO PT.	RADIUS	LENGTH
71 TO 72	3.00'	4.7'
73 TO 74	5.00'	4.8'
75 TO 76	3.00'	5.0'
77 TO 78	3.00'	6.4'
79 TO 80	3.00'	3.7'
81 TO 82	3.00'	4.0'
83 TO 84	3.00'	7.6'
85 TO 78	3.00'	4.2'
87 TO 88	3.00'	4.7'
89 TO 90	3.00'	7.0'
91 TO 92	3.00'	4.8'
93 TO 86	3.00'	2.8'



PROJ. MANAGER	B. KEEZER	BY	DATE
DESIGN-DETAILED	ECF	JRD	05/19
CHECKED-REVIEWED			
DESIGN-DETAILED			
DESIGN-DETAILED			
REVISIONS 1			
REVISIONS 2			
REVISIONS 3			
REVISIONS 4			
FIELD CHANGES			

SIGNALIZATION OF
CUMBERLAND MILLS ROTARY
GEOMETRIC LAYOUT (3 OF 4)

Date: 2/17/2020

Username: jrobert

Division: HIGHWAY

Filename: ... \MSTA019_Geol.youit_4.dgn

ITEM 609.11 - VERTICAL CURB TYPE 1		
PT. TO PT.	RADIUS	LENGTH
95A TO 98	-	83.4'
96 TO 97	-	56.0'
105 TO 106	-	28.9'
132 TO 133	-	27.1'
132A TO 133A	-	8.7'
98 TO 99	65'	40.5'
99 TO 100	102.51'	5.9'
104 TO 105	102.51'	44.3'

ITEM 609.238 - TERMINAL CURB TYPE 1 - 8FOOT		
PT. TO PT.	RADIUS	LENGTH
100 TO 101	102.51'	8.0'
102 TO 103	102.51'	8.0'
131 TO 132	-	8.0'
132A TO 131A	-	8.0'

ITEM 609.31 - CURB TYPE 3		
STA. TO STA.	OFFSET	LENGTH
66+60 TO 66+75	LT	16.0'
17+22 TO 17+44	RT	16.0'
47+85 TO 47+95	RT	15.9'
48+40 TO 48+50	RT	15.8'

ITEM 609.34 - CURB TYPE 5		
PT. TO PT.	RADIUS	LENGTH
107 TO 108	79.70'	9.5'
109 TO 134	-	4.3'
112 TO 113	-	8.8'
114 TO 115	79.70'	12.5'
116 TO 117	79.23'	7.1'
118 TO 135	-	7.8'
122 TO 123	79.23'	15.0'
124 TO 125	-	29.0'
127 TO 130	-	16.3'

ITEM 609.35 - CURB TYPE 5 - CIRCULAR		
PT. TO PT.	RADIUS	LENGTH
108 TO 109	3.00'	4.4'
134 TO 110	2.00'	4.0'
110 TO 111	2.00'	2.3'
111 TO 112	2.00'	3.1'
113 TO 107	3.00'	7.9'
115 TO 116	3.00'	5.5'
117 TO 118	3.00'	5.4'
135 TO 119	15.0'	4.2'
119 TO 121	6.41'	7.2'
121 TO 114	3.00'	4.5'
123 TO 124	3.00'	7.9'
125 TO 126	2.00'	3.3'
126 TO 127	5.00'	4.8'
130 TO 122	3.00'	3.7'

CURB INLET		
PT. TO PT.	RADIUS	LENGTH
103 TO 104	102.51'	4.0'

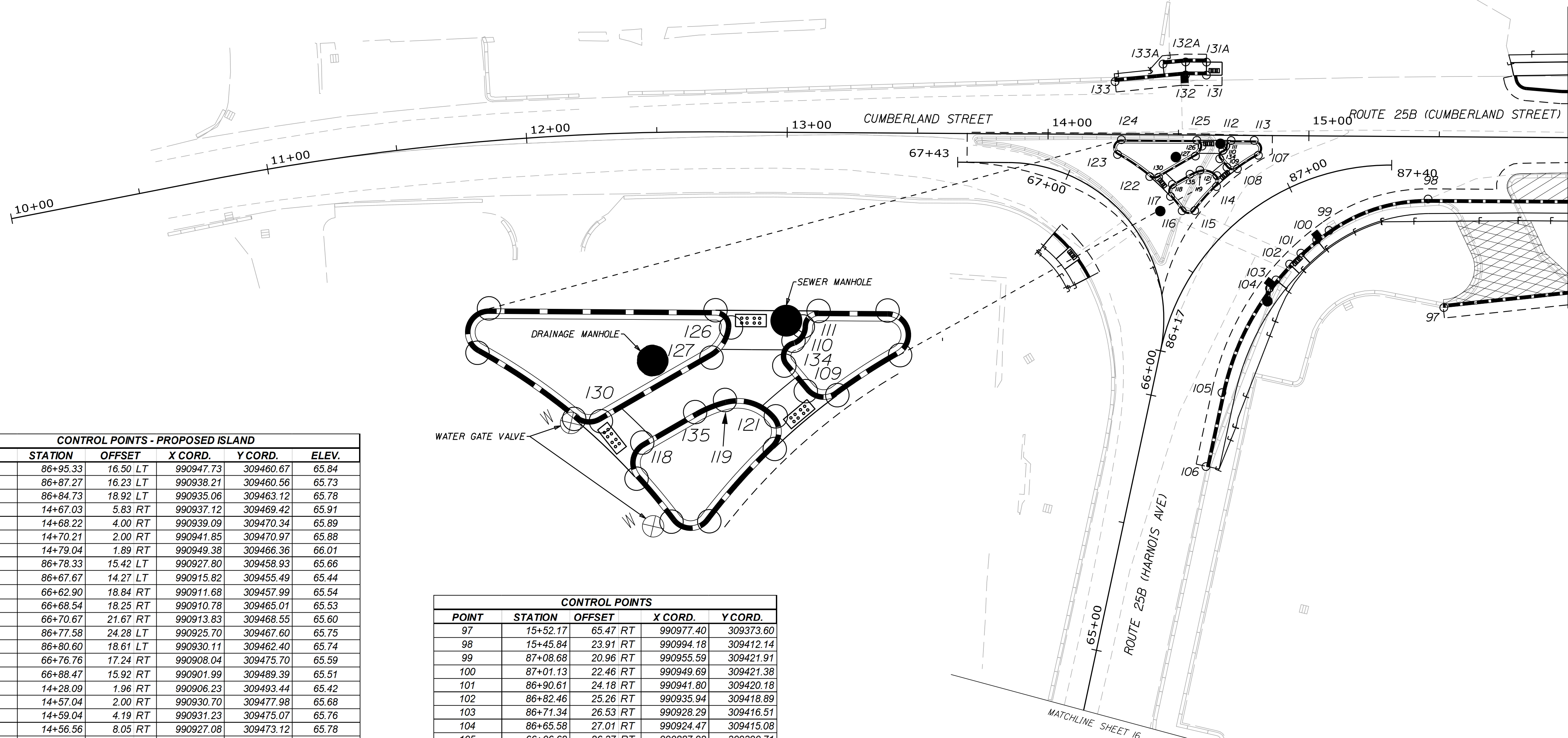

CONTROL POINTS - PROPOSED ISLAND					
POINT	STATION	OFFSET	X CORD.	Y CORD.	ELEV.
107	86+95.33	16.50 LT	990947.73	309460.67	65.84
108	86+87.27	16.23 LT	990938.21	309460.56	65.73
109	86+84.73	18.92 LT	990935.06	309463.12	65.78
110	14+67.03	5.83 RT	990937.12	309469.42	65.91
111	14+68.22	4.00 RT	990939.09	309470.34	65.89
112	14+70.21	2.00 RT	990941.85	309470.97	65.88
113	14+79.04	1.89 RT	990949.38	309466.36	66.01
114	86+78.33	15.42 LT	990927.80	309458.93	65.66
115	86+67.67	14.27 LT	990915.82	309455.49	65.44
116	66+62.90	18.84 RT	990911.68	309457.99	65.54
117	66+68.54	18.25 RT	990910.78	309465.01	65.53
118	66+70.67	21.67 RT	990913.83	309468.55	65.60
119	86+77.58	24.28 LT	990925.70	309467.60	65.75
121	86+80.60	18.61 LT	990930.11	309462.40	65.74
122	66+76.76	17.24 RT	990908.04	309475.70	65.59
123	66+88.47	15.92 RT	990901.99	309489.39	65.51
124	14+28.09	1.96 RT	990906.23	309493.44	65.42
125	14+57.04	2.00 RT	990930.70	309477.98	65.68
126	14+59.04	4.19 RT	990931.23	309475.07	65.76
127	14+56.56	8.05 RT	990927.08	309473.12	65.78
130	66+74.79	19.49 RT	990910.78	309473.65	65.62
134	14+65.88	9.01 LT	990934.45	309467.34	65.86
135	66+69.83	29.38 RT	990921.63	309468.29	65.70

CONTROL POINTS				
POINT	STATION	OFFSET	X CORD.	Y CORD.
97	15+52.17	65.47 RT	990977.40	309373.60
98	15+45.84	23.91 RT	990994.18	309412.14
99	87+08.68	20.96 RT	990955.59	309421.91
100	87+01.13	22.46 RT	990949.69	309421.38
101	86+90.61	24.18 RT	990941.80	309420.18
102	86+82.46	25.26 RT	990935.94	309418.89
103	86+71.34	26.53 RT	990928.29	309416.51
104	86+65.58	27.01 RT	990924.47	309415.08
105	66+06.62	26.37 RT	990887.92	309390.71
106	65+77.64	26.31 RT	990867.79	309369.86
131	14+60.53	23.00 LT	990946.98	309497.28
131A	14+60.55	28.00 LT	990949.66	309501.50
132	14+52.55	23.01 LT	990940.23	309501.54
132A	14+52.55	28.00 LT	990942.89	309505.76
133	14+25.56	20.28 LT	990915.93	309513.61
133A	14+43.88	27.15 LT	990935.10	309509.66

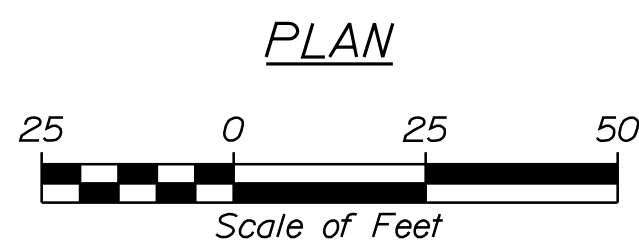

STATE OF MAINE
DEPARTMENT OF TRANSPORTATION
PROJECT NO. STP-1863(700)
WIN
18637.00
HIGHWAY PLANS



PROJ. MANAGER	B. KEEZER	DATE
DESIGN-DETAILED	ECF	05/19
CHECKED-REVIEWED		
DESIGN-DETAILED		
DESIGN-DETAILED		
REVISIONS 1		
REVISIONS 2		
REVISIONS 3		
REVISIONS 4		
FIELD CHANGES		

SIGNALIZATION OF
CUMBERLAND MILLS ROTARY
GEOMETRIC LAYOUT (4 OF 4)

SHEET NUMBER
19
OF 53

Date: 2/13/2020

Username: Kate.Maguire

Filename: ... \GEO\TECH\MSTA020_MAF&BLP1.dgn Division: GEOTECH

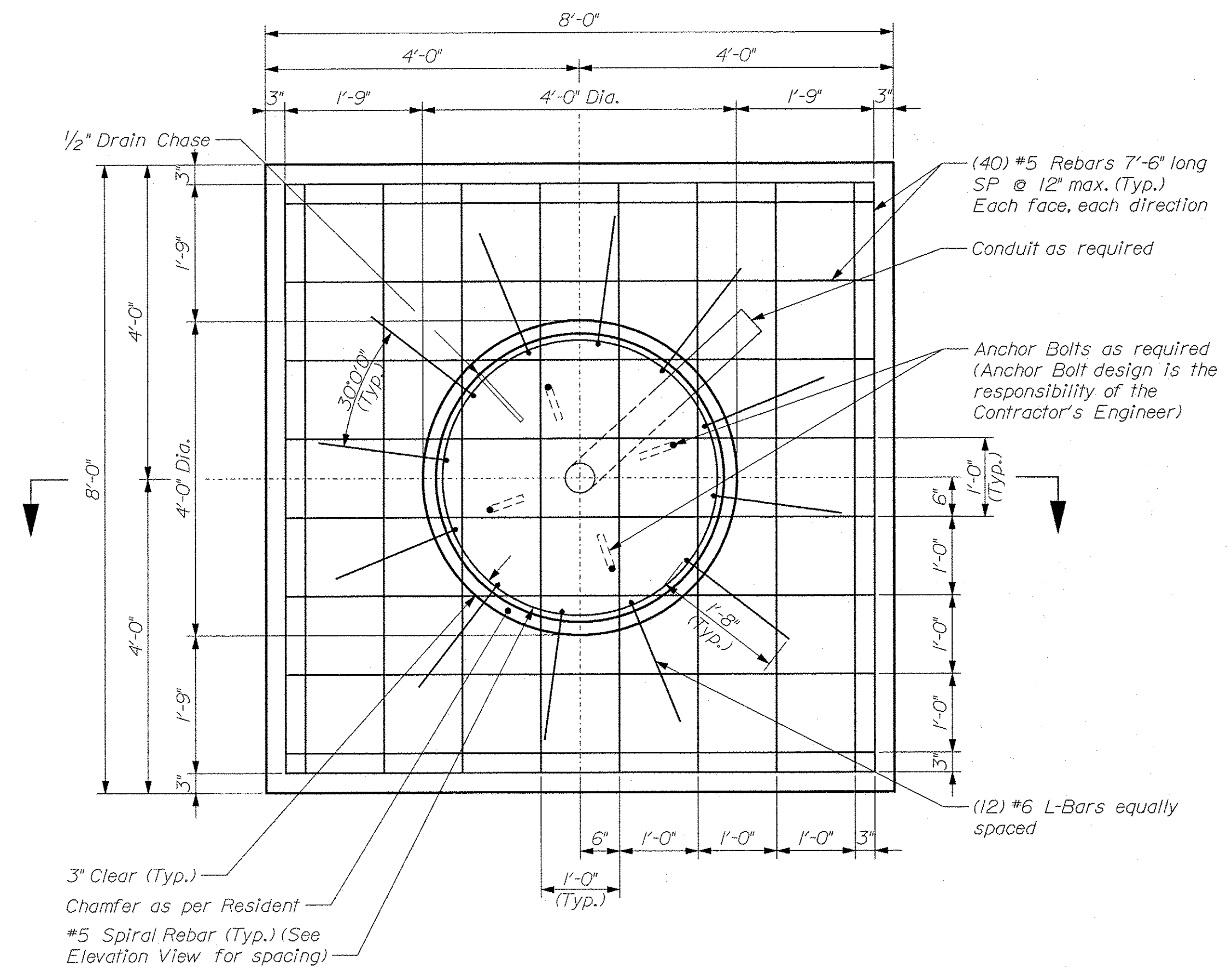

Spread Footing Plan View
Scale: 3/4" = 1'-0"

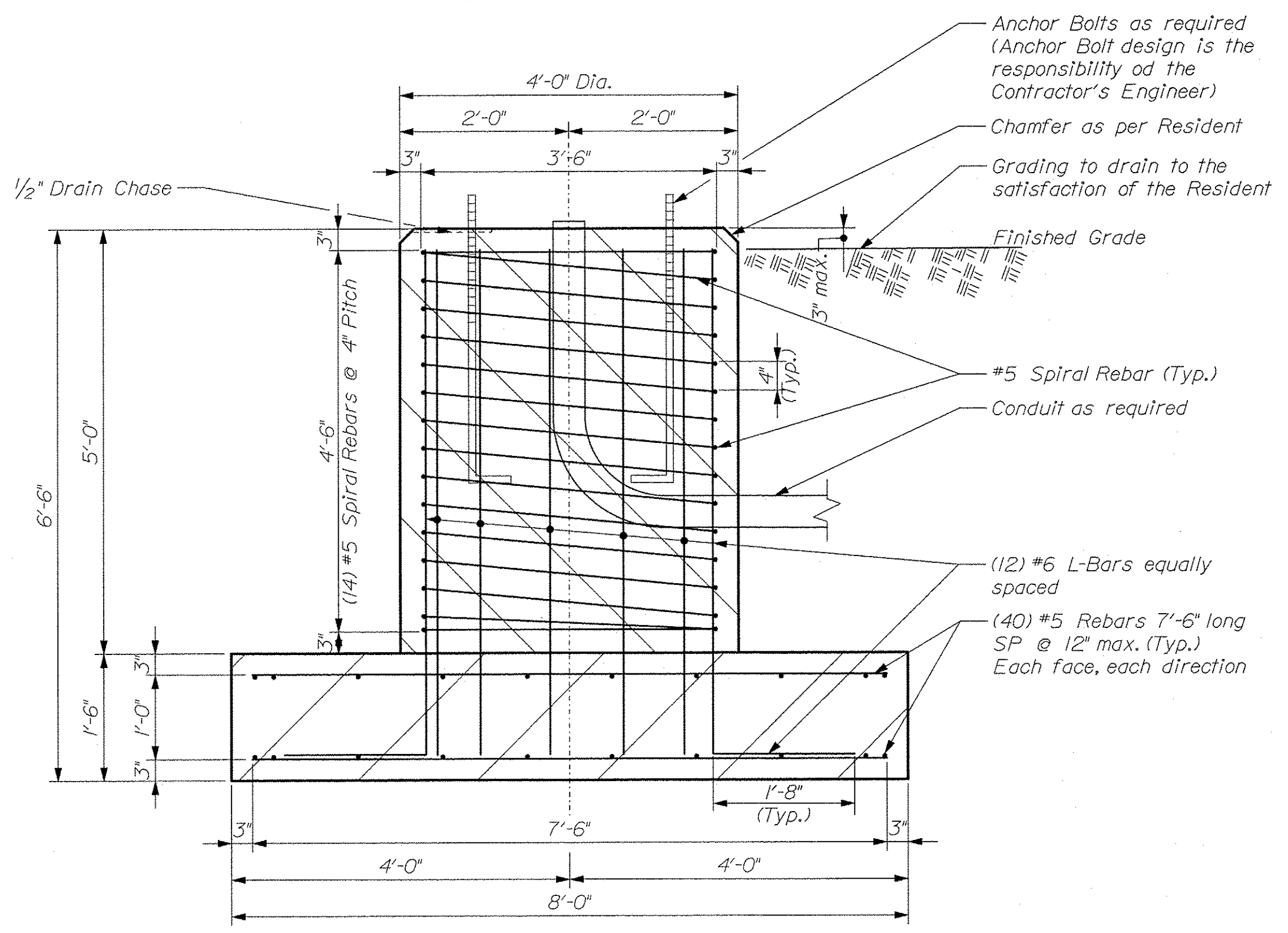

Spread Footing Elevation View
Scale: 3/4" = 1'-0"

MAST ARM A
Sta. 33+06, 18.8' Rt.

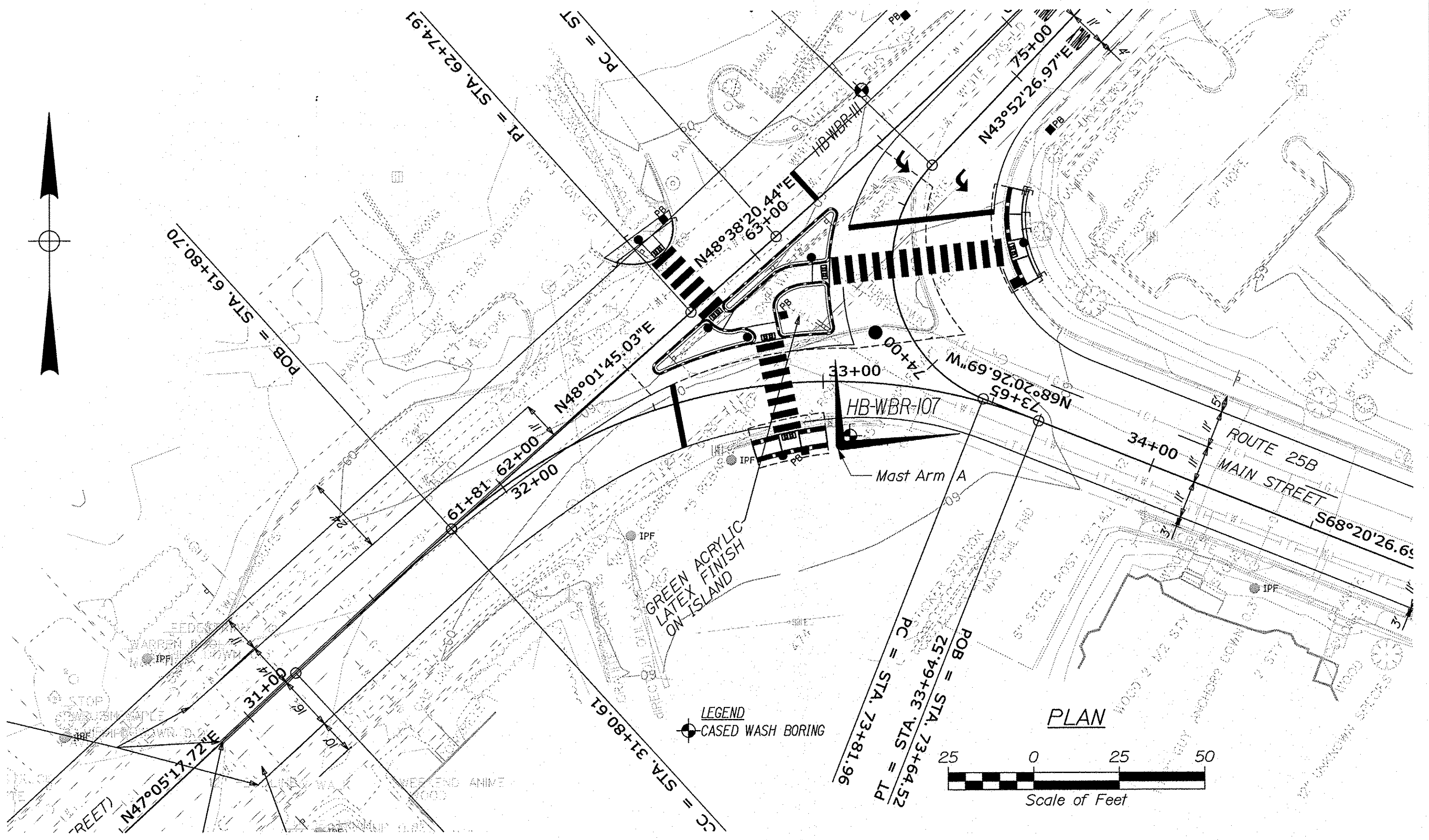

- NOTES:**
1. All reinforcing steel is to be grade 60 and conform to MaineDOT Standard Specification requirements along with any project specific Supplementals or Special Provisions.
 2. All rebar shall have 3" cover unless otherwise noted.
 3. For spread footing, L-Bars shall have a Min. 1'-8" Leg.
 4. Should there be a discrepancy between these Details and actual observed field conditions report it to the Resident immediately.
 5. Do not proceed with dependent work until any such discrepancy is resolved to the satisfaction of the Resident.
 6. Concrete to be Class LP with $f'c = 5,000$ PSI.

STATE OF MAINE DEPARTMENT OF TRANSPORTATION		STP-1863(700)	WIN 018637.00	HIGHWAY PLANS
PROJECT MANAGER DESIGN-DETAILED CHECKED-REVIEWED DESIGN2-DETAILED2 DESIGN3-DETAILED3 REVISIONS 1 REVISIONS 2 REVISIONS 3 REVISIONS 4 FIELD CHANGES	BY T. WHITE	DATE FEB 2020	SIGNATURE K. MAGUIRE	P.E. NUMBER 7120
WESTBROOK CUMBERLAND ROTARY MAST ARM FOUNDATION & BORING LOCATION PLAN				
SHEET NUMBER		20		
		OF 53		

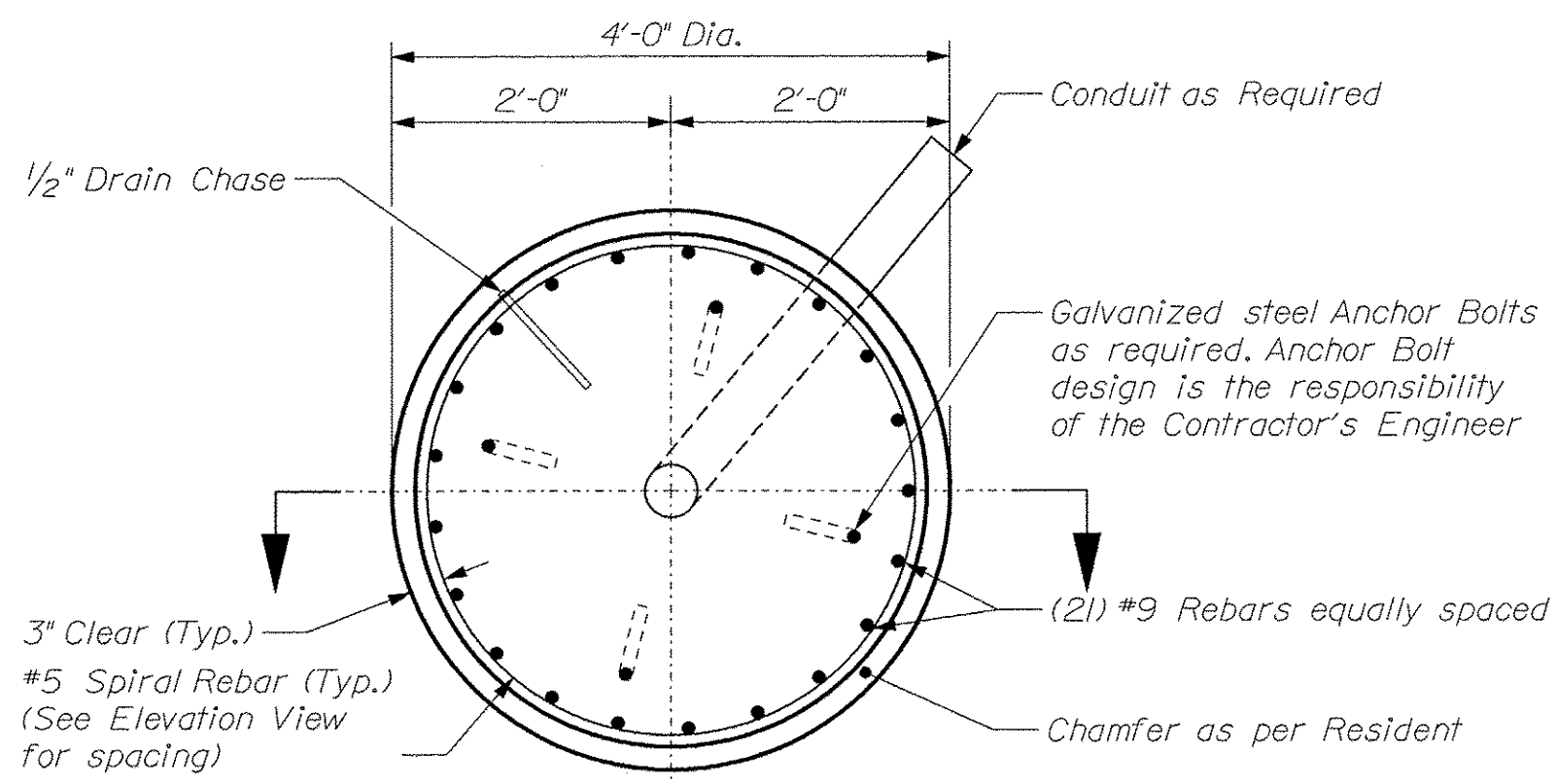

Drilled Shaft Plan View
Scale: 3/4" = 1'-0"

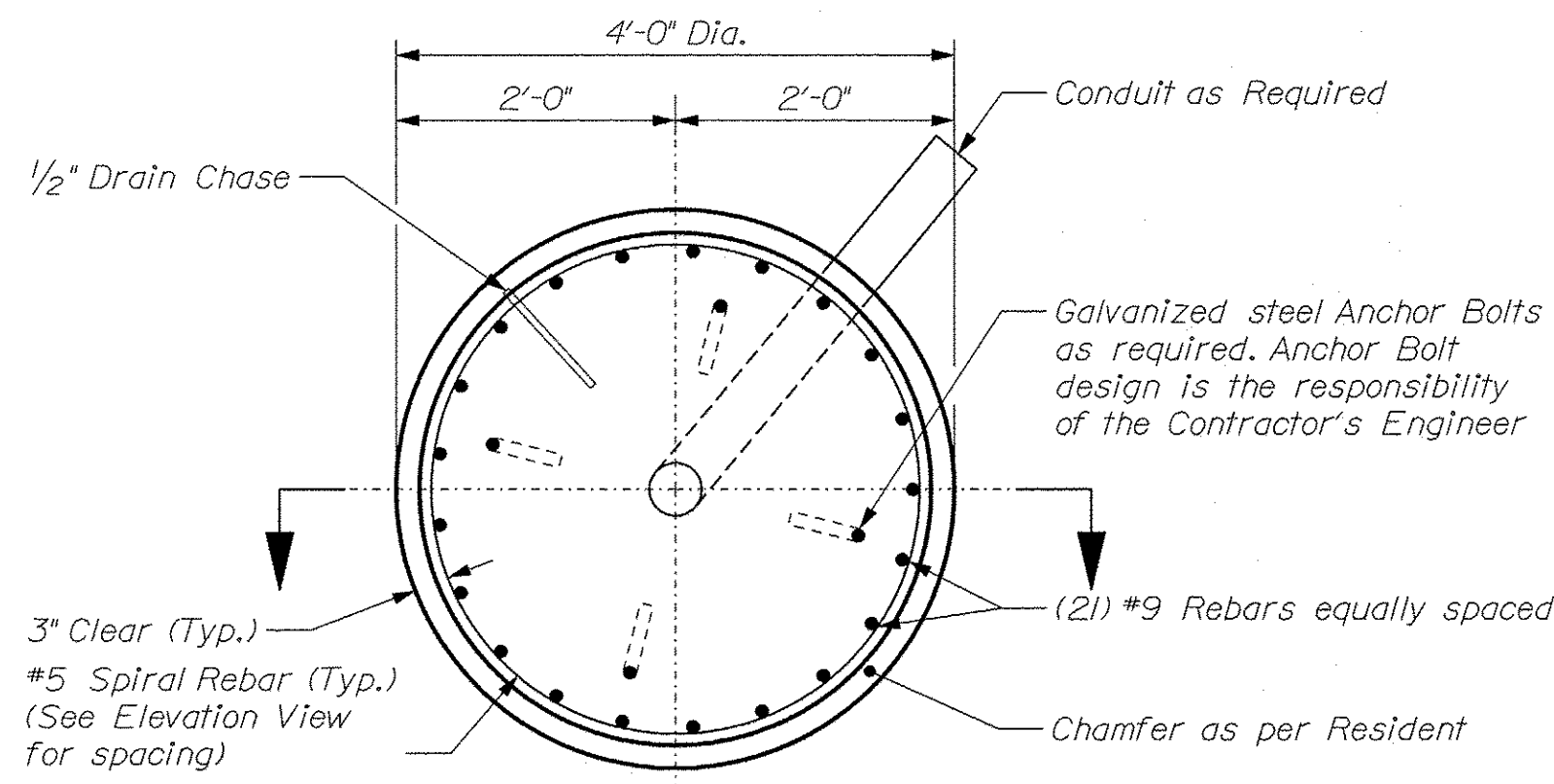

Drilled Shaft Plan View
Scale: 3/4" = 1'-0"

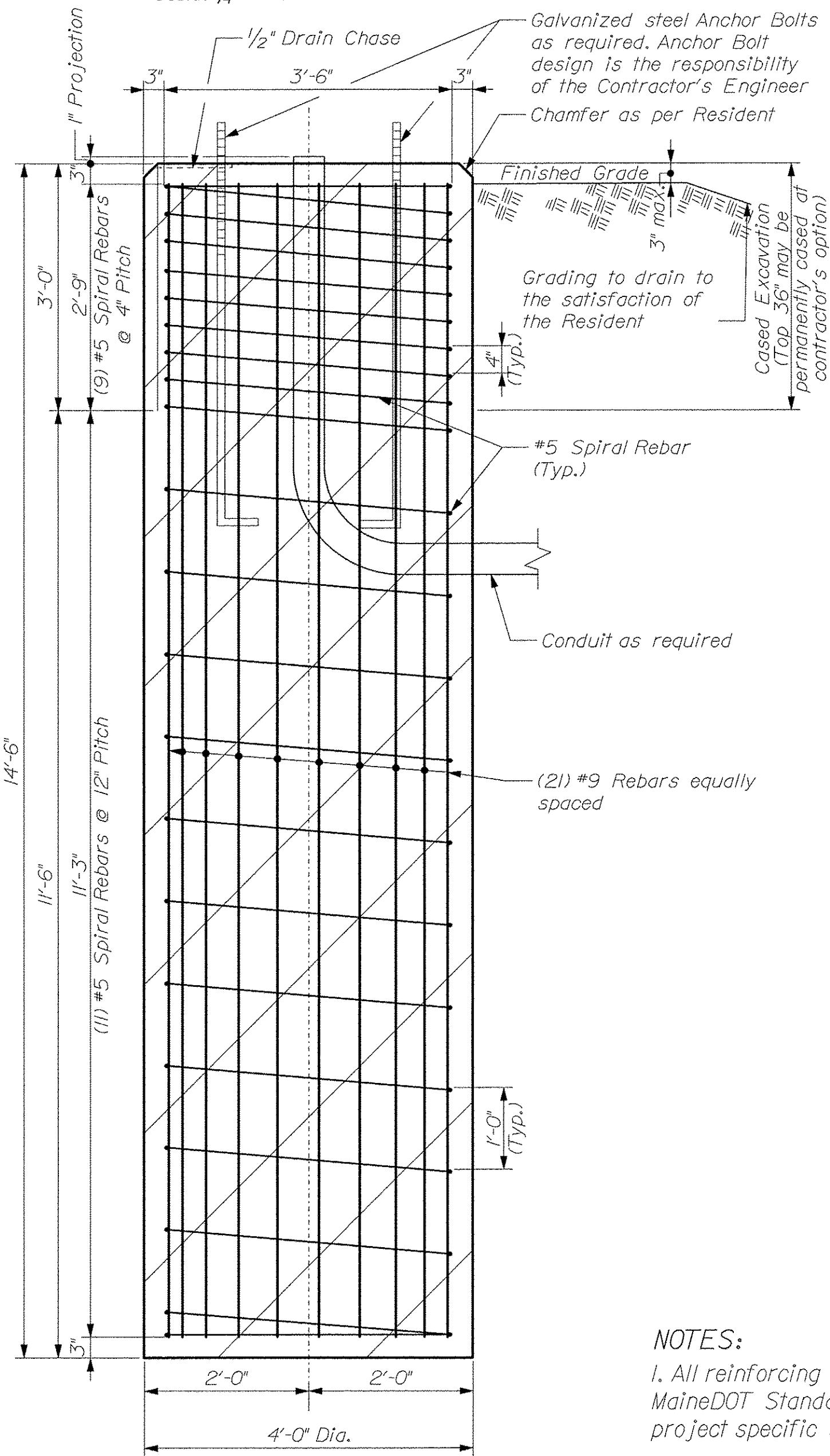

Drilled Shaft Elevation View
Scale: 3/4" = 1'-0"
MAST ARM A
Sta. 21+82, 20.8' Rt.

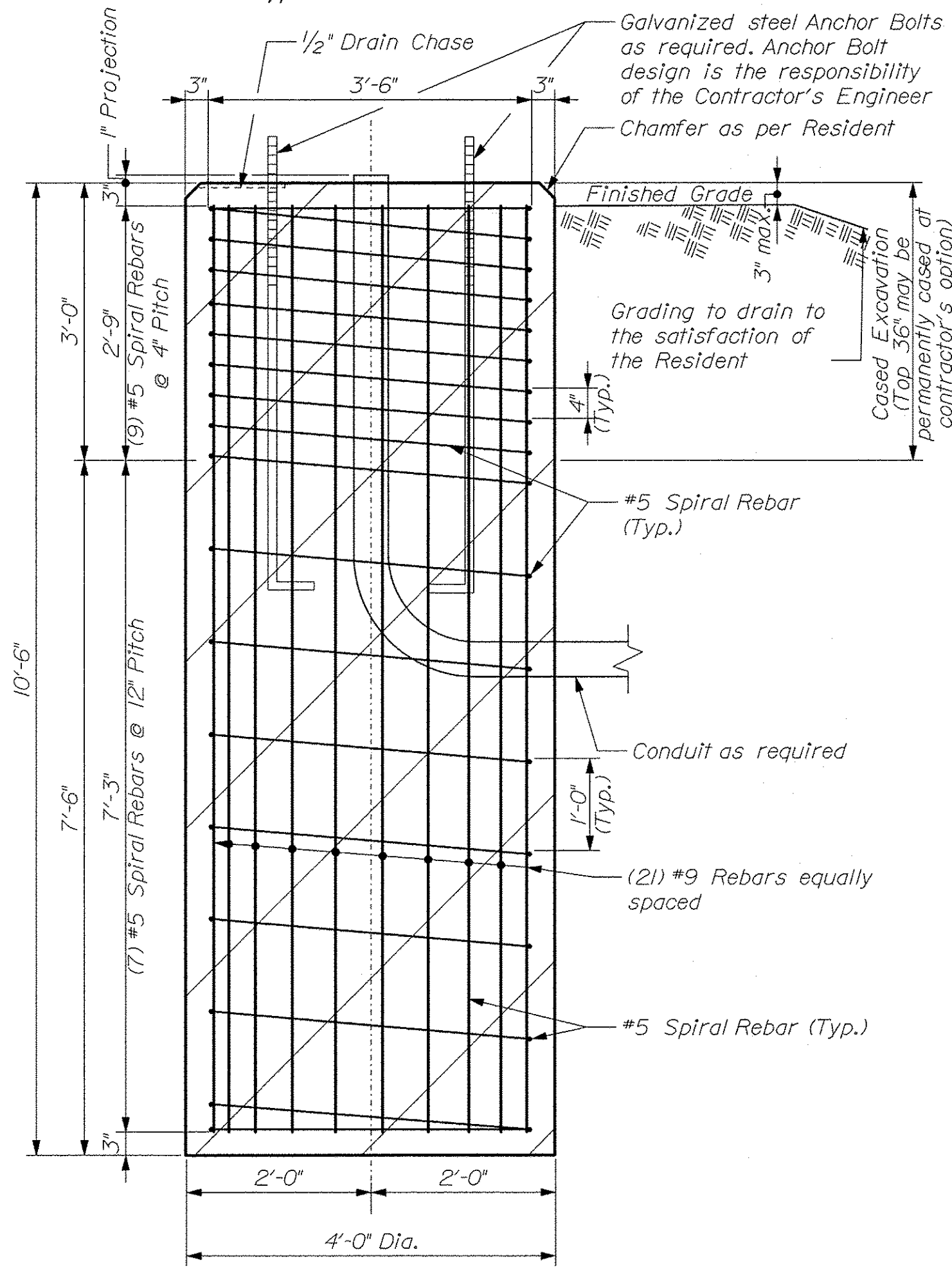

Drilled Shaft Elevation View
Scale: 3/4" = 1'-0"
MAST ARM B
Sta. 42+39, 11.8' Lt.

NOTES:

1. All reinforcing steel is to be grade 60 and conform to MaineDOT Standard Specification requirements along with any project specific Supplementals or Special Provisions.
2. All rebar shall have 3" cover unless otherwise noted.
3. Should there be a discrepancy between these Details and actual observed field conditions report it to the Resident immediately.
4. Do not proceed with dependent work until any such discrepancy is resolved to the satisfaction of the Resident.
5. Concrete to be Class LP with $f'c = 5,000$ PSI.

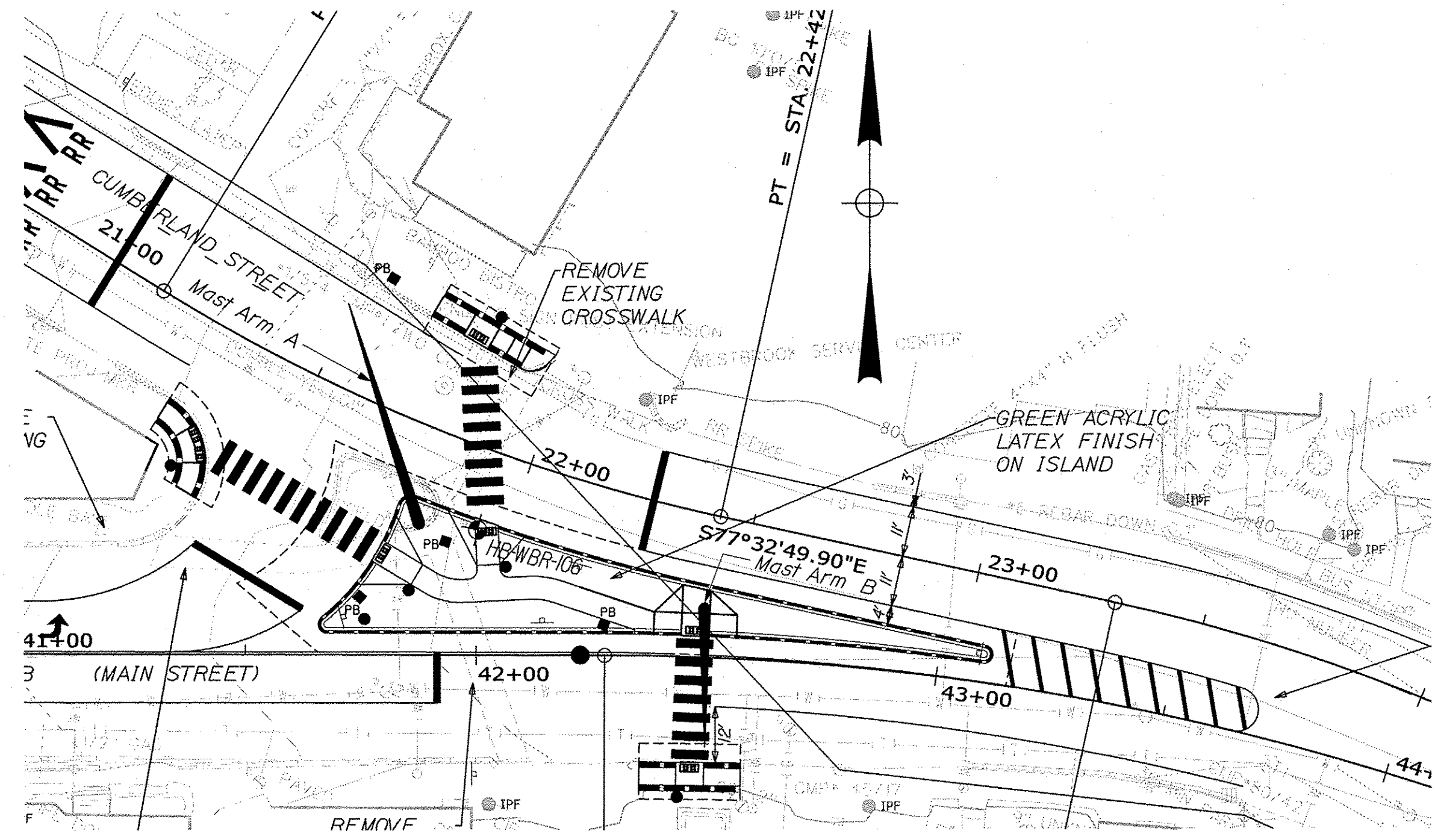

LEGEND
CASED WASH BORING
PLAN
Scale of Feet

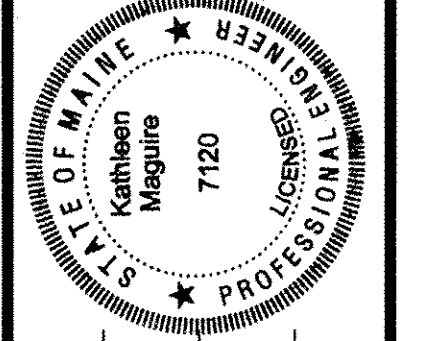

SIGNATURE: *Kathleen Maguire*
DATE: 2/13/2020
P.E. NUMBER: 7120

PROJ. MANAGER	DATE	BY
DESIGN-DETAILED		
CHECKED-REVIEWED		
DESIGN-DETAILED2	1-WHITE	FEB 2020
DESIGN-DETAILED3		
REVISIONS 1		
REVISIONS 2		
REVISIONS 3		
REVISIONS 4		
FIELD CHANGES		

WESTBROOK CUMBERLAND ROTARY
MAST ARM FOUNDATION & BORING LOCATION PLAN

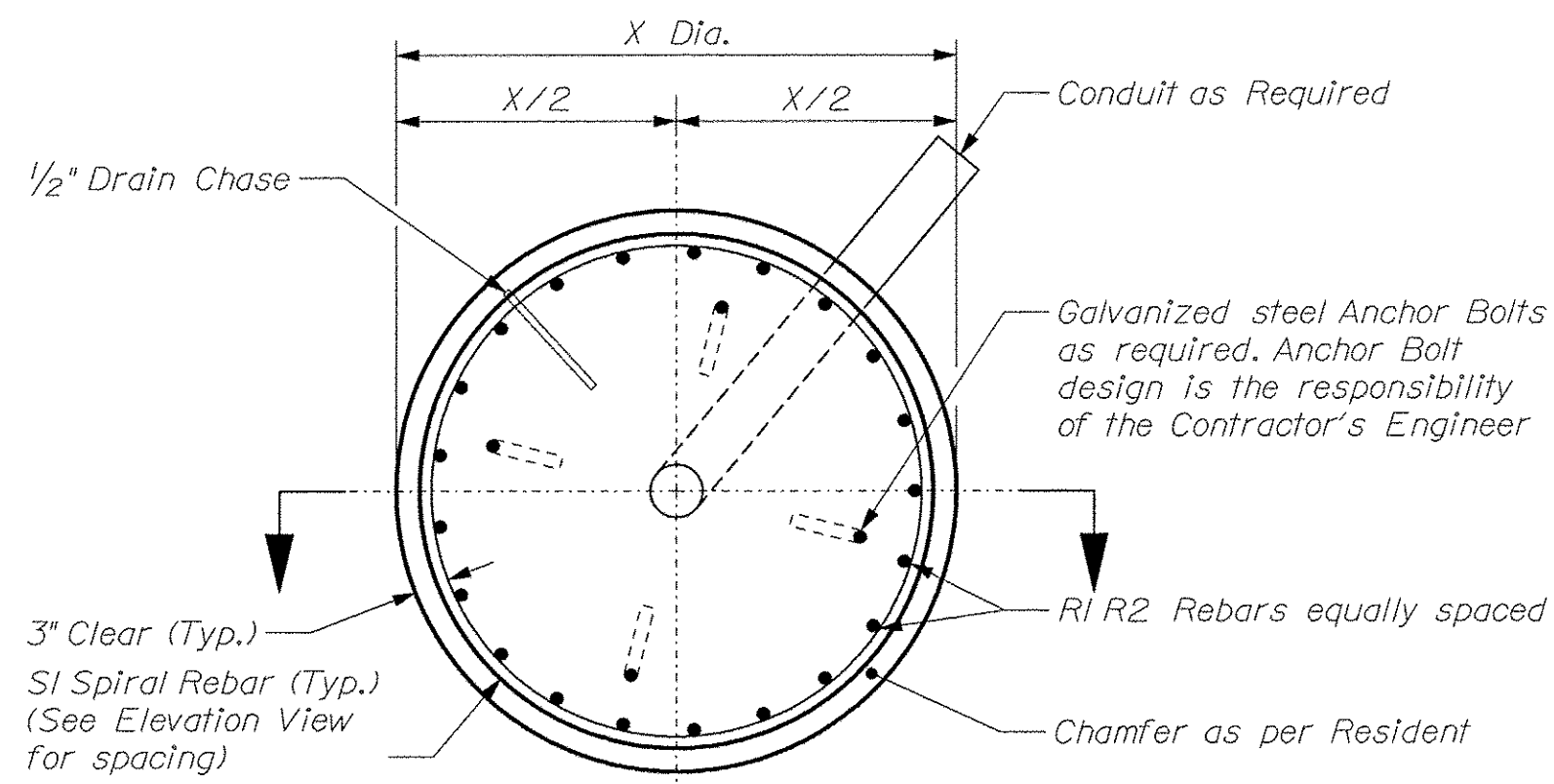

Drilled Shaft Plan View

Not to Scale (See Table for Drilled Shaft & Reinforcement Information)

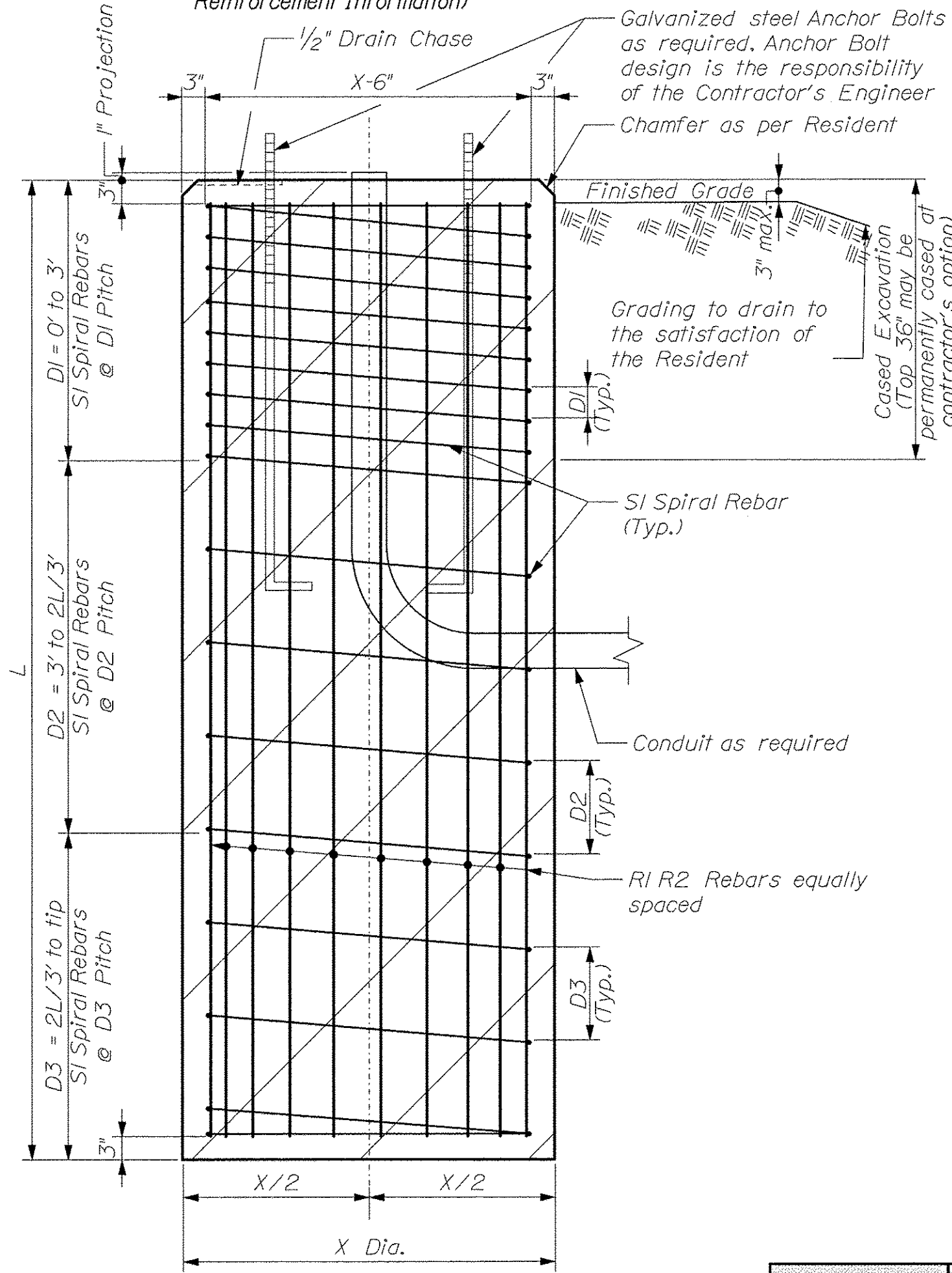

Drilled Shaft Elevation View

Not to Scale (See Table for Drilled Shaft & Reinforcement Information)

MAST ARMS A, B, C & D

- (A) Sta. 47+87, 31.5' Lt.
- (B) Sta. 48+54, 30.4' Rt.
- (C) Sta. 47+93, 43.5' Rt.
- (D) Sta. 48+39, 40.8' Lt.

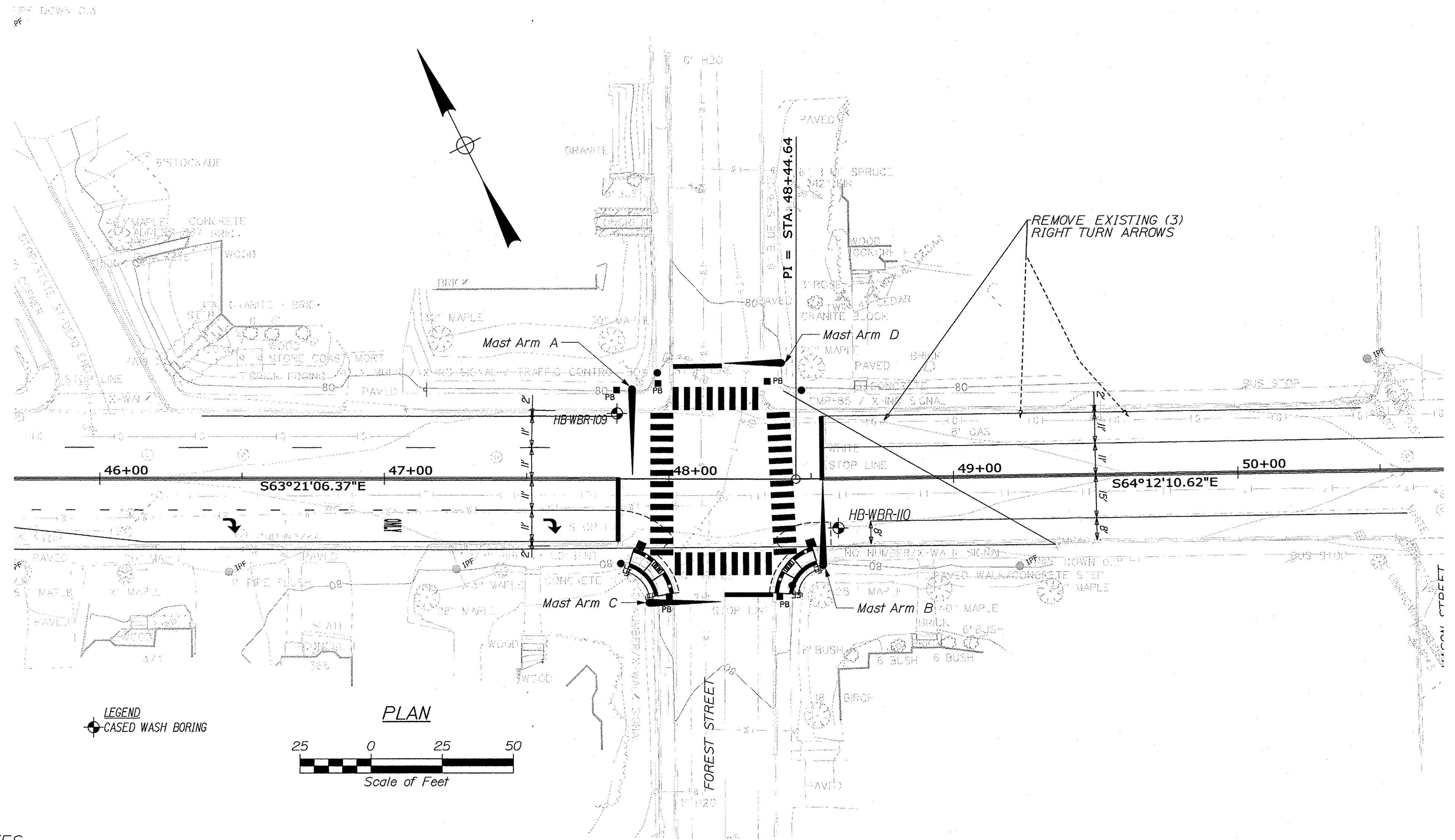

NOTES:

1. All reinforcing steel is to be grade 60 and conform to MaineDOT Standard Specification requirements along with any project specific Supplementals or Special Provisions.
2. All rebar shall have 3" cover unless otherwise noted.
3. Should there be a discrepancy between these Details and actual observed field conditions report it to the Resident immediately.
4. Do not proceed with dependent work until any such discrepancy is resolved to the satisfaction of the Resident.
5. Concrete to be Class LP with $f'c = 5,000$ PSI.

Mast Arm	Location	Approximate Station & Offset	X Diameter (feet)	L Length (feet)	R1 Longitudinal Rebars Quantity	R2 Longitudinal Rebars Size	S1 Spiral Rebars Size	Spiral Bar Spacing		
								D1 (in)	D2 (in)	D3 (in)
A	Main Street	47+87, 31.5' L	4.0	14.5	21	#9	#5	0 to 3 ft	3 ft to 2L/3 ft	2L/3 ft to tip
B	Main Street	48+54, 30.4' R	4.0	14.5	21	#9	#5	4	12	12
C	Main Street	47+93, 43.5' R	4.0	13.5	21	#9	#5	4	12	12
D	Main Street	48+39, 40.8' L	4.0	12.5	21	#9	#5	4	12	12

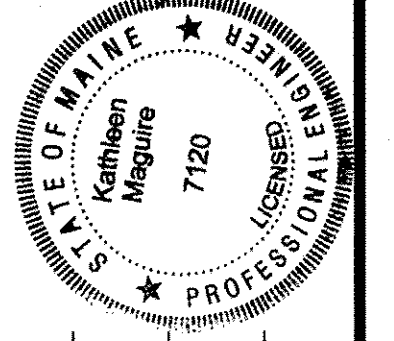

PROJ. MANAGER
DESIGN-DETAILED
CHECKED-REVIEWED
DESIGN-DETAILED
REVISIONS 1
REVISIONS 2
REVISIONS 3
REVISIONS 4
FIELD CHANGES

DATE	BY
FEB 2020	T. WHITE
FEB 2020	K. MAGUIRE

WESTBROOK
CUMBERLAND ROTARY
MAST ARM FOUNDATION & BORING LOCATION PLAN

SHEET NUMBER

23

OF 53

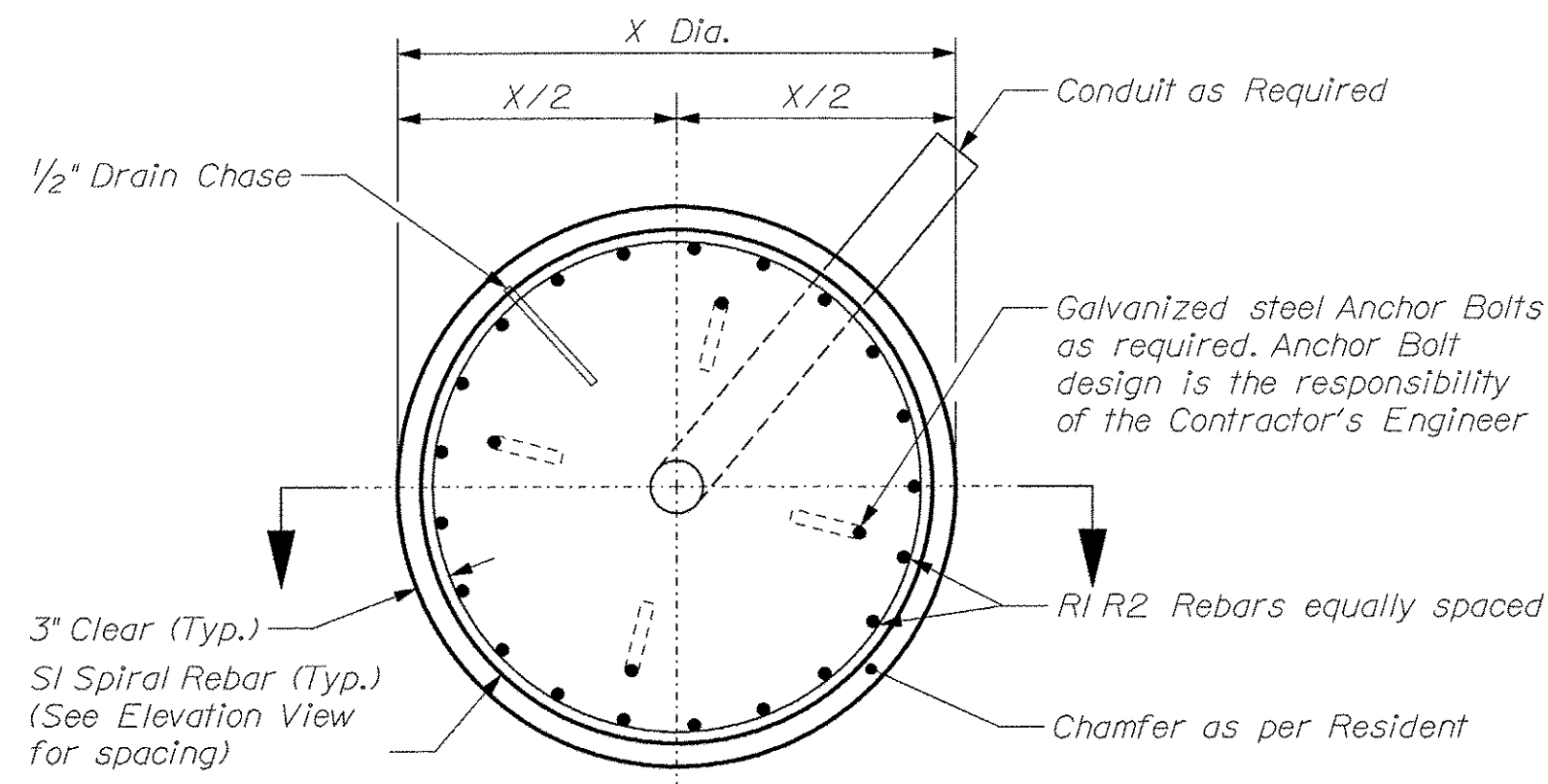

Drilled Shaft Plan View

Not to Scale (See Table for Drilled Shaft & Reinforcement Information)

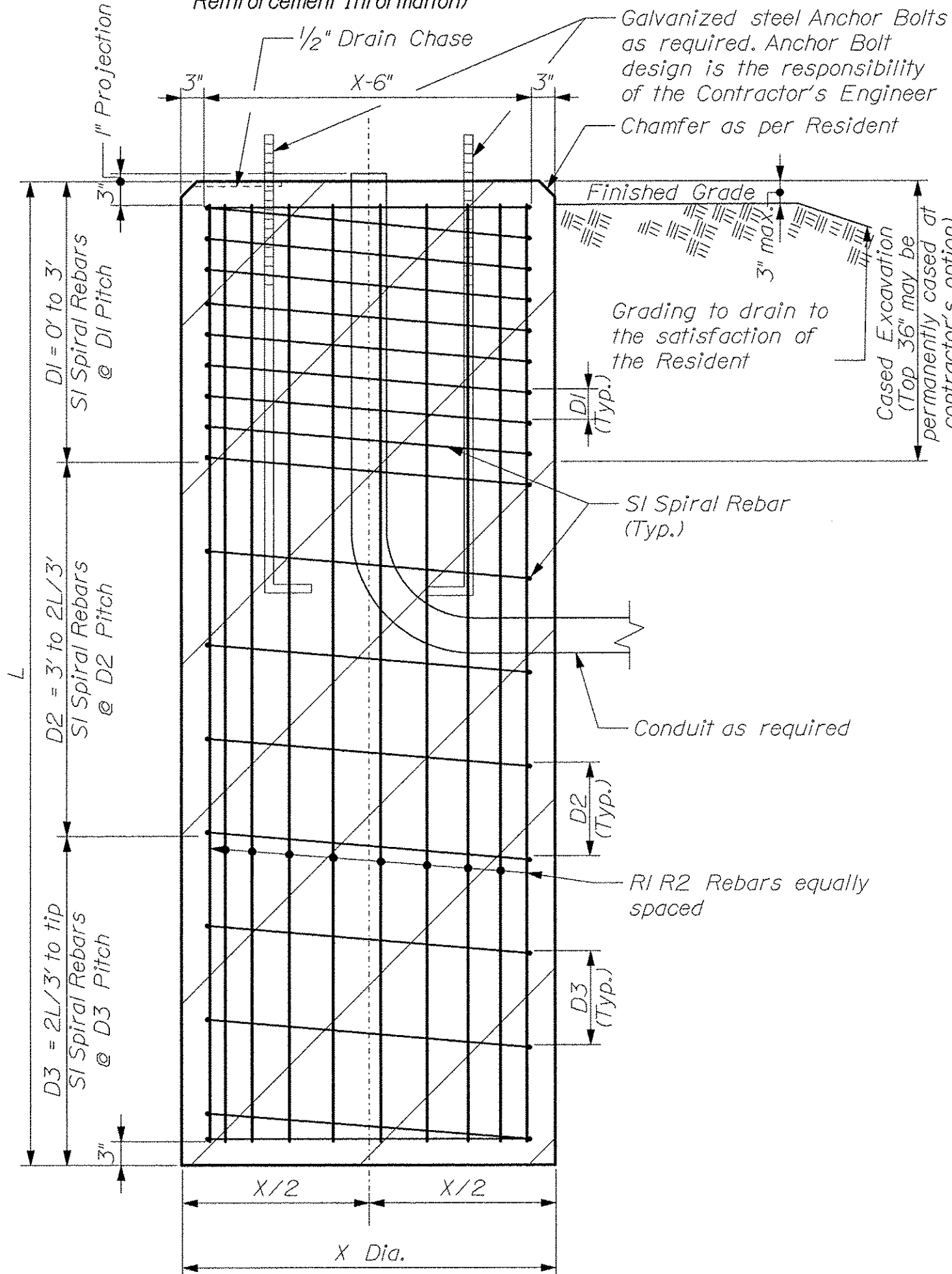

Drilled Shaft Elevation View

Not to Scale (See Table for Drilled Shaft & Reinforcement Information)

MAST ARMS A, B & C

- (A) Sta. 17+28, 17.1' Lt.
- (B) Sta. 16+39, 30.3' Rt.
- (C) Sta. 19+87, 26.3' Rt.

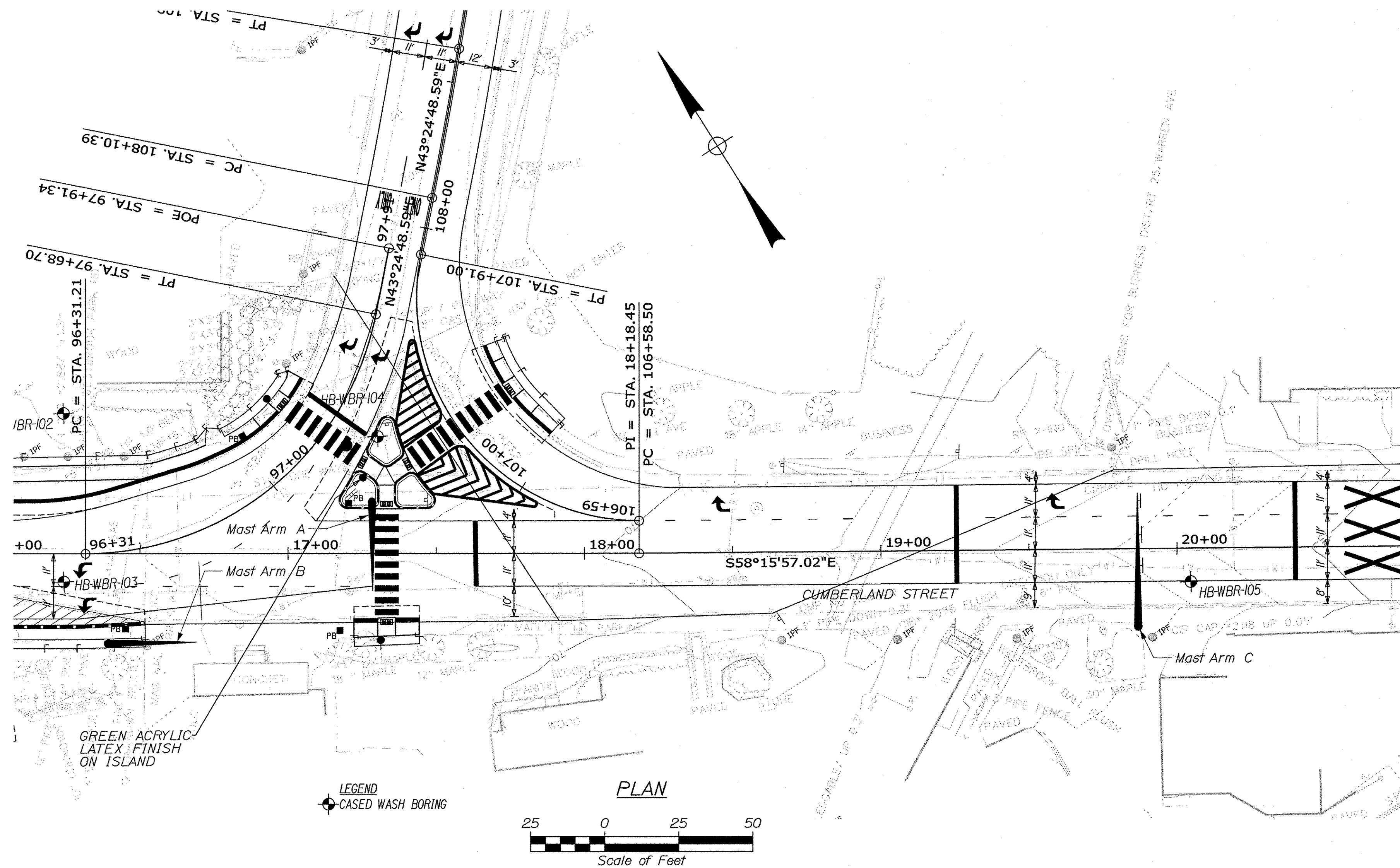

NOTES:

1. All reinforcing steel is to be grade 60 and conform to MaineDOT Standard Specification requirements along with any project specific Supplementals or Special Provisions.
2. All rebar shall have 3" cover unless otherwise noted.
3. Should there be a discrepancy between these Details and actual observed field conditions report it to the Resident immediately.
4. Do not proceed with dependent work until any such discrepancy is resolved to the satisfaction of the Resident.
5. Concrete to be Class LP with $f'c = 5,000$ PSI.

Mast Arm	Location	Approximate Station & Offset	X Diameter (feet)	L Length (feet)	R1 Longitudinal Rebars Quantity	R2 Longitudinal Rebars Size	S1 Spiral Rebars Size	Spiral Bar Spacing		
								D1 (in)	D2 (in)	D3 (in)
								0 to 3 ft	3 ft to 2L/3 ft	2L/3 ft to tip
A	Cumberland Street	17+28, 17.1' L	4.0	14.5	21	#9	#5	4	12	12
B	Cumberland Street	16+39, 30.3' R	4.0	13.5	21	#9	#5	4	12	12
C	Cumberland Street	19+87, 26.3' R	4.0	14.0	21	#9	#5	4	12	12

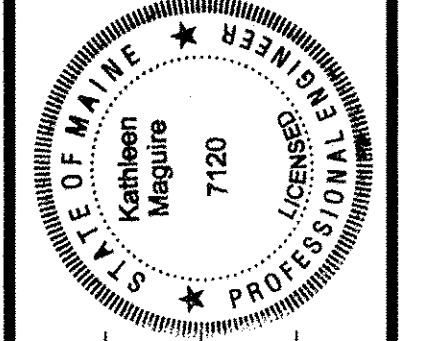

Signature: Kathleen Maguire
Date: 2/13/2020
P.E. Number: 7120

PROJ. MANAGER	DATE	BY
DESIGN-DETAILED		
CHECKED-REVIEWED		
DESIGN-DETAILED	FEB 2020	T. WHITE
DESIGN-DETAILED		
REVISIONS 1		
REVISIONS 2		
REVISIONS 3		
REVISIONS 4		
FIELD CHANGES		

WESTBROOK
CUMBERLAND ROTARY
MAST ARM FOUNDATION & BORING LOCATION PLAN

SHEET NUMBER

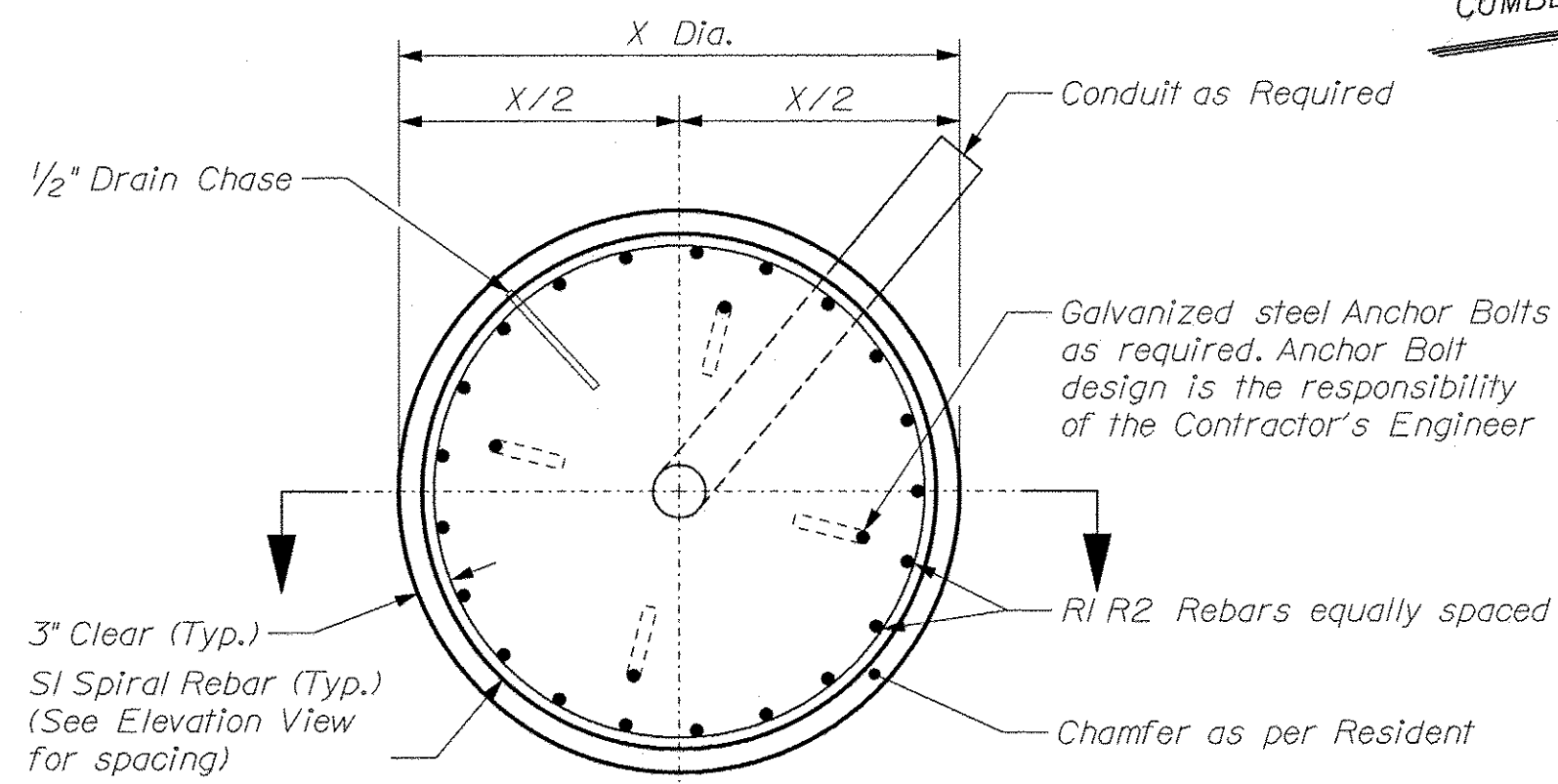

Drilled Shaft Plan View

Not to Scale (See Table for Drilled Shaft & Reinforcement Information)

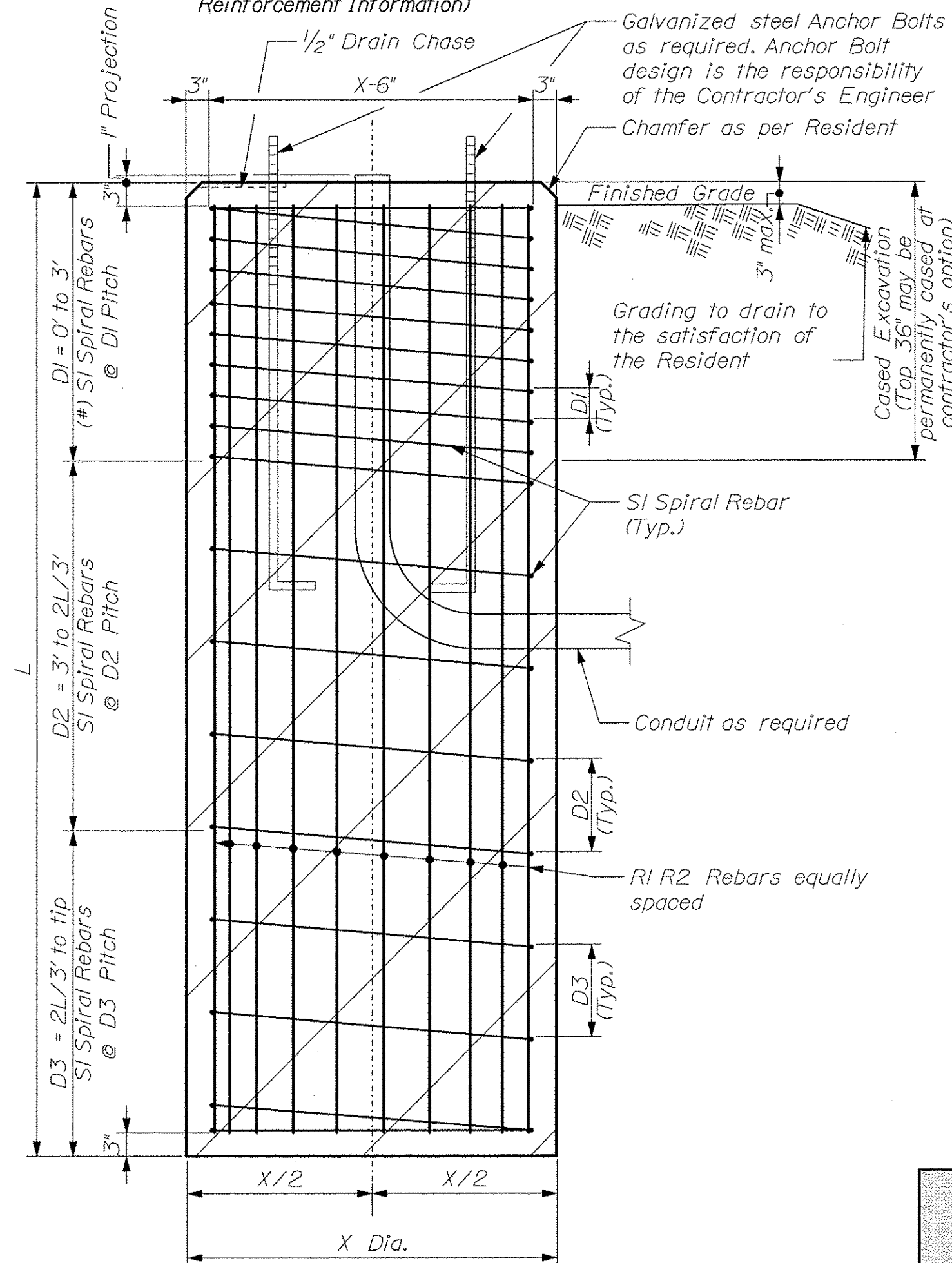

Drilled Shaft Elevation View

Not to Scale (See Table for Drilled Shaft & Reinforcement Information)

MAST ARMS A, B, C & D

- (A) Sta. 15+94, 30.4' Lt.
- (B) Sta. 64+85, 20.6' Rt.
- (C) Sta. 14+58, 4.2' Rt.
- (D) Sta. 86+42, 33.6' Rt.

NOTES:

1. All reinforcing steel is to be grade 60 and conform to MaineDOT Standard Specification requirements along with any project specific Supplementals or Special Provisions.
2. All rebar shall have 3" cover unless otherwise noted.
3. Should there be a discrepancy between these Details and actual observed field conditions report it to the Resident immediately.
4. Do not proceed with dependent work until any such discrepancy is resolved to the satisfaction of the Resident.
5. Concrete to be Class LP with $f'c = 5,000$ PSI.

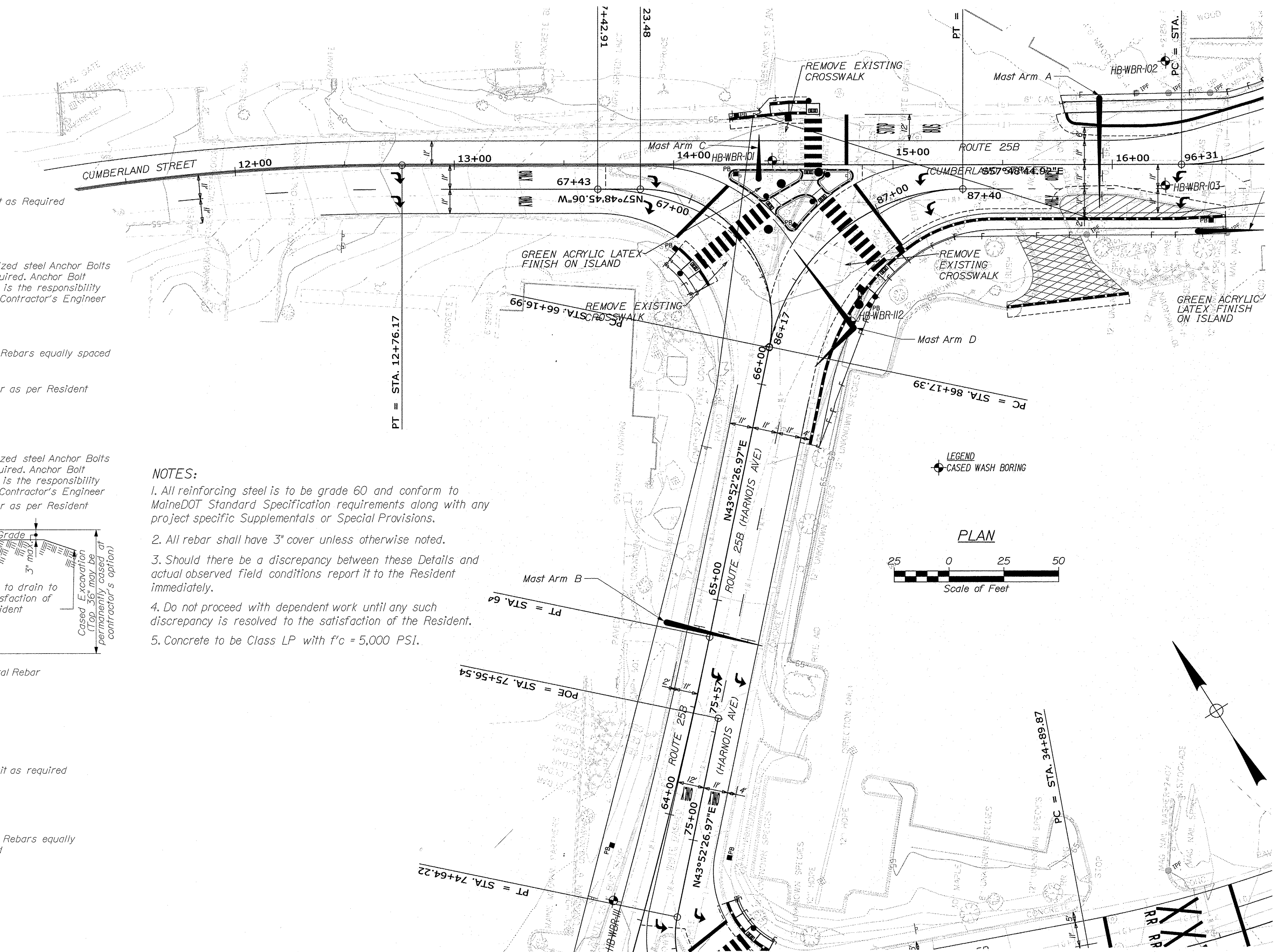

Mast Arm	Location	Approximate Station & Offset	X Diameter (feet)	L Length (feet)	R1 Longitudinal Rebars Quantity	R2 Longitudinal Rebars Size	S1 Spiral Rebars Size	Spiral Bar Spacing		
								D1 (in)	D2 (in)	D3 (in)
A	Cumberland Street	15+94, 30.4' L	4.0	15.5	21	#9	#5	4	12	12
B	Harnois Ave	64+85, 20.6' L	4.0	12.5	21	#9	#5	4	4	12
C	Cumberland Street	14+58, 4.2' R	4.0	8.5	21	#9	#5	4	4	12
D	Harnois Ave & Washington Street	86+42, 33.6' R	4.0	11.5	21	#9	#5	4	4	12

STATE OF MAINE
DEPARTMENT OF TRANSPORTATION
STP-1863(700)

WIN 018637.00
HIGHWAY PLANS

STATE OF MAINE
Professional Engineer
Kathleen Maguire
7120
2/13/2020

PROJ. MANAGER: [Signature]
DATE: [Signature]
BY: [Signature]
DATE: [Signature]

DESIGN-DETAILED
CHECKED-REVIEWED
DESIGN-DETAILED
DESIGN-DETAILED
REVISIONS 1
REVISIONS 2
REVISIONS 3
REVISIONS 4
FIELD CHANGES

WESTBROOK
CUMBERLAND ROTARY
MAST ARM FOUNDATION & BORING LOCATION PLAN

SHEET NUMBER
25
OF 53

Maine Department of Transportation Soil/Book Exploration Log US_CUSTOMARY_UNITS		Project: Intersection Improvements and Signalization of Cumberland Mills Location: Westbrook, Maine		Boring No.: HB-WBR-101 WIN: 018637.00																																																								
Driller: S. W. Cole Explorations, LLC	Elevation (ft.): 65.5	Auger ID/00: 5" Solid-Shaft	Operator: M. Leonard	Datum: NAVD83	Sampler: Standard Split Spoon																																																							
Logged By: J. Dubois	Rig Type: Diedrich D-50	Home Wt./Fall: 140W/30"	Drilling Method: Cased Wash	Core Barrel: N/A	Water Level: 27 ft (after drilling)																																																							
Date Start/Finish: 09-09-2018	Drilling Method: Cased Wash	Core Barrel: N/A	Water Level: 27 ft (after drilling)	Home Efficiency Factor: 0.918	Home Type: Automatic																																																							
Boring Location: 150' EMBR-11-20' L WESTBROOK STREET	Drilling Method: Cased Wash	Core Barrel: N/A	Water Level: 27 ft (after drilling)	Home Efficiency Factor: 0.918	Home Type: Automatic																																																							
<p>Definitions: S = Soil Spoon Sample, SA = Split Stem Auger, SS = Standard Split Spoon Sample Attempt, T = Thin Wall Tube Sample, M = Measured This Well Tube Sample Attempt, V = Field Vane Shear Test, W = Pocket Penetrometer WMC = Weight of Rod or Casing, H = Horizontal Field Shear Test, A = Blow Count, B = Blows per Foot</p> <p>Abbreviations: F = Rock Core Sample, S = Soil Spoon Sample, SA = Split Stem Auger, SS = Standard Split Spoon Sample Attempt, T = Thin Wall Tube Sample, M = Measured This Well Tube Sample Attempt, V = Field Vane Shear Test, W = Pocket Penetrometer WMC = Weight of Rod or Casing, H = Horizontal Field Shear Test, A = Blow Count, B = Blows per Foot</p>																																																												
<table border="1"> <thead> <tr> <th>Depth (ft.)</th> <th>Soil No.</th> <th>Pen./Frac. (ft)</th> <th>Depth (ft.)</th> <th>Pen./Frac. (ft)</th> <th>Soil Description and Remarks</th> <th>Laboratory Testing Result/AASHTO and Unified Class</th> </tr> </thead> <tbody> <tr> <td>10</td> <td>24/14</td> <td>0.90 - 2.90</td> <td>8/21/4</td> <td>12</td> <td>18</td> <td>55A</td> <td>3" of Pavement. Brown, damp, medium dense, SAND, little gravel, trace silt, fine to medium sand, (F111).</td> </tr> <tr> <td>20</td> <td>24/10</td> <td>2.90 - 4.90</td> <td>4/4/3/3</td> <td>7</td> <td>11</td> <td></td> <td>Brown, damp, medium dense, SAND, trace gravel, trace silt, fine to medium sand, (F111).</td> </tr> <tr> <td>30</td> <td>24/18</td> <td>5.00 - 7.00</td> <td>3/2/2/3</td> <td>4</td> <td>6</td> <td>24</td> <td>30A1: Similar to above. 30B1: Gray-brown, moist, medium stiff, silty CLAY, (Presumpscot Formation). PP4-0-2.5 ksf</td> </tr> <tr> <td>40</td> <td>24/24</td> <td>10.00 - 12.00</td> <td>3/2/3/4</td> <td>5</td> <td>8</td> <td>52</td> <td>Failed 55k10 mm vane attempt. Gray-brown, wet, medium stiff, silty CLAY, (Presumpscot Formation). PP4-0-2.5 ksf</td> </tr> <tr> <td>50</td> <td>24/17</td> <td>15.00 - 17.00</td> <td>5/6/1/2</td> <td>10</td> <td>15</td> <td>59</td> <td>50A1: Gray, wet, very stiff, silty CLAY, (Presumpscot Formation). 50B1: Gray, wet, medium dense, SAND, trace silt, (Presumpscot Formation).</td> </tr> <tr> <td>60</td> <td>1/0</td> <td>19.70 - 19.78</td> <td>50-1"</td> <td></td> <td></td> <td></td> <td>Casing refusal on cobble at 216.7 ft bgs. No recovery. Bottom of Exploration at 19.8 feet below ground surface. Soil Refusal.</td> </tr> </tbody> </table>						Depth (ft.)	Soil No.	Pen./Frac. (ft)	Depth (ft.)	Pen./Frac. (ft)	Soil Description and Remarks	Laboratory Testing Result/AASHTO and Unified Class	10	24/14	0.90 - 2.90	8/21/4	12	18	55A	3" of Pavement. Brown, damp, medium dense, SAND, little gravel, trace silt, fine to medium sand, (F111).	20	24/10	2.90 - 4.90	4/4/3/3	7	11		Brown, damp, medium dense, SAND, trace gravel, trace silt, fine to medium sand, (F111).	30	24/18	5.00 - 7.00	3/2/2/3	4	6	24	30A1: Similar to above. 30B1: Gray-brown, moist, medium stiff, silty CLAY, (Presumpscot Formation). PP4-0-2.5 ksf	40	24/24	10.00 - 12.00	3/2/3/4	5	8	52	Failed 55k10 mm vane attempt. Gray-brown, wet, medium stiff, silty CLAY, (Presumpscot Formation). PP4-0-2.5 ksf	50	24/17	15.00 - 17.00	5/6/1/2	10	15	59	50A1: Gray, wet, very stiff, silty CLAY, (Presumpscot Formation). 50B1: Gray, wet, medium dense, SAND, trace silt, (Presumpscot Formation).	60	1/0	19.70 - 19.78	50-1"				Casing refusal on cobble at 216.7 ft bgs. No recovery. Bottom of Exploration at 19.8 feet below ground surface. Soil Refusal.
Depth (ft.)	Soil No.	Pen./Frac. (ft)	Depth (ft.)	Pen./Frac. (ft)	Soil Description and Remarks	Laboratory Testing Result/AASHTO and Unified Class																																																						
10	24/14	0.90 - 2.90	8/21/4	12	18	55A	3" of Pavement. Brown, damp, medium dense, SAND, little gravel, trace silt, fine to medium sand, (F111).																																																					
20	24/10	2.90 - 4.90	4/4/3/3	7	11		Brown, damp, medium dense, SAND, trace gravel, trace silt, fine to medium sand, (F111).																																																					
30	24/18	5.00 - 7.00	3/2/2/3	4	6	24	30A1: Similar to above. 30B1: Gray-brown, moist, medium stiff, silty CLAY, (Presumpscot Formation). PP4-0-2.5 ksf																																																					
40	24/24	10.00 - 12.00	3/2/3/4	5	8	52	Failed 55k10 mm vane attempt. Gray-brown, wet, medium stiff, silty CLAY, (Presumpscot Formation). PP4-0-2.5 ksf																																																					
50	24/17	15.00 - 17.00	5/6/1/2	10	15	59	50A1: Gray, wet, very stiff, silty CLAY, (Presumpscot Formation). 50B1: Gray, wet, medium dense, SAND, trace silt, (Presumpscot Formation).																																																					
60	1/0	19.70 - 19.78	50-1"				Casing refusal on cobble at 216.7 ft bgs. No recovery. Bottom of Exploration at 19.8 feet below ground surface. Soil Refusal.																																																					

Maine Department of Transportation Soil/Book Exploration Log US_CUSTOMARY_UNITS		Project: Intersection Improvements and Signalization of Cumberland Mills Location: Westbrook, Maine		Boring No.: HB-WBR-102 WIN: 018637.00																																																								
Driller: S. W. Cole Explorations, LLC	Elevation (ft.): 68.2	Auger ID/00: 5" Solid-Shaft	Operator: M. Leonard	Datum: NAVD83	Sampler: Standard Split Spoon																																																							
Logged By: J. Dubois	Rig Type: Diedrich D-50	Home Wt./Fall: 140W/30"	Drilling Method: Cased Wash	Core Barrel: N/A	Water Level: 27 ft (after drilling)																																																							
Date Start/Finish: 09-12-2018	Drilling Method: Cased Wash	Core Barrel: N/A	Water Level: 27 ft (after drilling)	Home Efficiency Factor: 0.918	Home Type: Automatic																																																							
Boring Location: 150' EMBR-11-20' L WESTBROOK STREET	Drilling Method: Cased Wash	Core Barrel: N/A	Water Level: 27 ft (after drilling)	Home Efficiency Factor: 0.918	Home Type: Automatic																																																							
<p>Definitions: S = Soil Spoon Sample, SA = Split Stem Auger, SS = Standard Split Spoon Sample Attempt, T = Thin Wall Tube Sample, M = Measured This Well Tube Sample Attempt, V = Field Vane Shear Test, W = Pocket Penetrometer WMC = Weight of Rod or Casing, H = Horizontal Field Shear Test, A = Blow Count, B = Blows per Foot</p> <p>Abbreviations: F = Rock Core Sample, S = Soil Spoon Sample, SA = Split Stem Auger, SS = Standard Split Spoon Sample Attempt, T = Thin Wall Tube Sample, M = Measured This Well Tube Sample Attempt, V = Field Vane Shear Test, W = Pocket Penetrometer WMC = Weight of Rod or Casing, H = Horizontal Field Shear Test, A = Blow Count, B = Blows per Foot</p>																																																												
<table border="1"> <thead> <tr> <th>Depth (ft.)</th> <th>Soil No.</th> <th>Pen./Frac. (ft)</th> <th>Depth (ft.)</th> <th>Pen./Frac. (ft)</th> <th>Soil Description and Remarks</th> <th>Laboratory Testing Result/AASHTO and Unified Class</th> </tr> </thead> <tbody> <tr> <td>10</td> <td>24/10</td> <td>0.00 - 2.00</td> <td>2/3/3/2</td> <td>6</td> <td>9</td> <td>55A</td> <td>Dark brown, damp, stiff, sandy SILT, trace gravel, with organic (F011).</td> </tr> <tr> <td>20</td> <td>24/20</td> <td>2.00 - 4.00</td> <td>5/10/12/10</td> <td>22</td> <td>34</td> <td></td> <td>20A1: Brown, damp, dense, silty SAND, little gravel, (F111).</td> </tr> <tr> <td>30</td> <td>24/24</td> <td>5.00 - 7.00</td> <td>2/2/3/4</td> <td>5</td> <td>8</td> <td>30</td> <td>30A1: Similar to above. 30B1: Gray-brown, moist, medium stiff, silty CLAY, blocky structure, (Presumpscot Formation). PP4-0-5.5 ksf</td> </tr> <tr> <td>40</td> <td>24/24</td> <td>10.00 - 12.00</td> <td>1/1/1/1</td> <td>2</td> <td>3</td> <td>42</td> <td>Gray-brown, wet, soft, silty CLAY, (Presumpscot Formation). PP4-0-2.0 ksf</td> </tr> <tr> <td>50</td> <td>24/24</td> <td>15.00 - 17.00</td> <td>WBR-12"/WIP-12" Sun=67/27 pcf</td> <td></td> <td></td> <td>50</td> <td>Gray, wet, soft to medium stiff, silty CLAY, (Presumpscot Formation). 55k10 mm row torque readings: V1: 18.0/1.0 ft-lbs V2: 21.0/2.0 ft-lbs</td> </tr> <tr> <td>60</td> <td>24/24</td> <td>20.00 - 22.00</td> <td>WDR/WIP-18"</td> <td></td> <td></td> <td>PROBE</td> <td>Similar to above. Advanced by hydraulic pushed rod probe from 22 to 24.5 feet. Bottom of Exploration at 24.5 feet below ground surface. Rod Probe Refusal.</td> </tr> </tbody> </table>						Depth (ft.)	Soil No.	Pen./Frac. (ft)	Depth (ft.)	Pen./Frac. (ft)	Soil Description and Remarks	Laboratory Testing Result/AASHTO and Unified Class	10	24/10	0.00 - 2.00	2/3/3/2	6	9	55A	Dark brown, damp, stiff, sandy SILT, trace gravel, with organic (F011).	20	24/20	2.00 - 4.00	5/10/12/10	22	34		20A1: Brown, damp, dense, silty SAND, little gravel, (F111).	30	24/24	5.00 - 7.00	2/2/3/4	5	8	30	30A1: Similar to above. 30B1: Gray-brown, moist, medium stiff, silty CLAY, blocky structure, (Presumpscot Formation). PP4-0-5.5 ksf	40	24/24	10.00 - 12.00	1/1/1/1	2	3	42	Gray-brown, wet, soft, silty CLAY, (Presumpscot Formation). PP4-0-2.0 ksf	50	24/24	15.00 - 17.00	WBR-12"/WIP-12" Sun=67/27 pcf			50	Gray, wet, soft to medium stiff, silty CLAY, (Presumpscot Formation). 55k10 mm row torque readings: V1: 18.0/1.0 ft-lbs V2: 21.0/2.0 ft-lbs	60	24/24	20.00 - 22.00	WDR/WIP-18"			PROBE	Similar to above. Advanced by hydraulic pushed rod probe from 22 to 24.5 feet. Bottom of Exploration at 24.5 feet below ground surface. Rod Probe Refusal.
Depth (ft.)	Soil No.	Pen./Frac. (ft)	Depth (ft.)	Pen./Frac. (ft)	Soil Description and Remarks	Laboratory Testing Result/AASHTO and Unified Class																																																						
10	24/10	0.00 - 2.00	2/3/3/2	6	9	55A	Dark brown, damp, stiff, sandy SILT, trace gravel, with organic (F011).																																																					
20	24/20	2.00 - 4.00	5/10/12/10	22	34		20A1: Brown, damp, dense, silty SAND, little gravel, (F111).																																																					
30	24/24	5.00 - 7.00	2/2/3/4	5	8	30	30A1: Similar to above. 30B1: Gray-brown, moist, medium stiff, silty CLAY, blocky structure, (Presumpscot Formation). PP4-0-5.5 ksf																																																					
40	24/24	10.00 - 12.00	1/1/1/1	2	3	42	Gray-brown, wet, soft, silty CLAY, (Presumpscot Formation). PP4-0-2.0 ksf																																																					
50	24/24	15.00 - 17.00	WBR-12"/WIP-12" Sun=67/27 pcf			50	Gray, wet, soft to medium stiff, silty CLAY, (Presumpscot Formation). 55k10 mm row torque readings: V1: 18.0/1.0 ft-lbs V2: 21.0/2.0 ft-lbs																																																					
60	24/24	20.00 - 22.00	WDR/WIP-18"			PROBE	Similar to above. Advanced by hydraulic pushed rod probe from 22 to 24.5 feet. Bottom of Exploration at 24.5 feet below ground surface. Rod Probe Refusal.																																																					

Maine Department of Transportation Soil/Book Exploration Log US_CUSTOMARY_UNITS		Project: Intersection Improvements and Signalization of Cumberland Mills Location: Westbrook, Maine		Boring No.: HB-WBR-103 WIN: 018637.00																																																								
Driller: S. W. Cole Explorations, LLC	Elevation (ft.): 67.6	Auger ID/00: 5" Solid-Shaft	Operator: M. Leonard	Datum: NAVD83	Sampler: Standard Split Spoon																																																							
Logged By: J. Dubois	Rig Type: Diedrich D-50	Home Wt./Fall: 140W/30"	Drilling Method: Cased Wash	Core Barrel: N/A	Water Level: 27 ft (after drilling)																																																							
Date Start/Finish: 09-12-2018	Drilling Method: Cased Wash	Core Barrel: N/A	Water Level: 27 ft (after drilling)	Home Efficiency Factor: 0.918	Home Type: Automatic																																																							
Boring Location: 150' EMBR-11-20' L WESTBROOK STREET	Drilling Method: Cased Wash	Core Barrel: N/A	Water Level: 27 ft (after drilling)	Home Efficiency Factor: 0.918	Home Type: Automatic																																																							
<p>Definitions: S = Soil Spoon Sample, SA = Split Stem Auger, SS = Standard Split Spoon Sample Attempt, T = Thin Wall Tube Sample, M = Measured This Well Tube Sample Attempt, V = Field Vane Shear Test, W = Pocket Penetrometer WMC = Weight of Rod or Casing, H = Horizontal Field Shear Test, A = Blow Count, B = Blows per Foot</p> <p>Abbreviations: F = Rock Core Sample, S = Soil Spoon Sample, SA = Split Stem Auger, SS = Standard Split Spoon Sample Attempt, T = Thin Wall Tube Sample, M = Measured This Well Tube Sample Attempt, V = Field Vane Shear Test, W = Pocket Penetrometer WMC = Weight of Rod or Casing, H = Horizontal Field Shear Test, A = Blow Count, B = Blows per Foot</p>																																																												
<table border="1"> <thead> <tr> <th>Depth (ft.)</th> <th>Soil No.</th> <th>Pen./Frac. (ft)</th> <th>Depth (ft.)</th> <th>Pen./Frac. (ft)</th> <th>Soil Description and Remarks</th> <th>Laboratory Testing Result/AASHTO and Unified Class</th> </tr> </thead> <tbody> <tr> <td>10</td> <td>24/19</td> <td>0.80 - 2.80</td> <td>36/11/9/6</td> <td>20</td> <td>31</td> <td>55A</td> <td>7.5" of Pavement. 10A1: Gray, damp, dense, gravelly SAND, trace silt, (F111) - (Blow Count). 10B1: 5" of wood at 21.5 ft bgs. 10C1: Brown, damp, medium dense, silty SAND, little gravel, (F111). 20A1: Brown, damp, medium dense, SAND, same silt, fine to medium sand, (F111). 20B1: Gray-brown, moist, stiff, silty CLAY, blocky structure, (Presumpscot Formation). Similar to above. PP4-0-7.0 ksf</td> </tr> <tr> <td>20</td> <td>24/14</td> <td>2.80 - 4.80</td> <td>8/8/7/5</td> <td>15</td> <td>23</td> <td></td> <td></td> </tr> <tr> <td>30</td> <td>24/24</td> <td>5.00 - 7.00</td> <td>3/4/5/6</td> <td>9</td> <td>14</td> <td>40</td> <td>30A1: Similar to above. 30B1: Gray-brown, moist, stiff, silty CLAY, blocky structure, (Presumpscot Formation). PP4-0-2.5 ksf</td> </tr> <tr> <td>40</td> <td>24/24</td> <td>10.00 - 12.00</td> <td>1/1/1/2</td> <td>2</td> <td>3</td> <td>40</td> <td>40A1: (10.0-10.8 ft): Similar to above except gray and medium stiff to soft. 40B1: 5.0-6.0 ksf 40C1: (10.0-12.0 ft): Gray, wet, medium stiff to soft, silty CLAY, (Presumpscot Formation).</td> </tr> <tr> <td>50</td> <td>24/24</td> <td>15.00 - 17.00</td> <td>WBR-12"/WIP-12" Sun=67/27 pcf</td> <td></td> <td></td> <td>50</td> <td>Gray, wet, soft to medium stiff, silty CLAY, (Presumpscot Formation). 55k10 mm row torque readings: V1: 18.0/1.0 ft-lbs V2: 21.0/2.0 ft-lbs</td> </tr> <tr> <td>60</td> <td>24/24</td> <td>20.00 - 22.00</td> <td>WDR/WIP-18"</td> <td></td> <td></td> <td>PROBE</td> <td>Similar to above. Advanced by hydraulic pushed rod probe from 22 to 21.1 ft bgs. Bottom of Exploration at 21.6 feet below ground surface. Rod Probe Refusal.</td> </tr> </tbody> </table>						Depth (ft.)	Soil No.	Pen./Frac. (ft)	Depth (ft.)	Pen./Frac. (ft)	Soil Description and Remarks	Laboratory Testing Result/AASHTO and Unified Class	10	24/19	0.80 - 2.80	36/11/9/6	20	31	55A	7.5" of Pavement. 10A1: Gray, damp, dense, gravelly SAND, trace silt, (F111) - (Blow Count). 10B1: 5" of wood at 21.5 ft bgs. 10C1: Brown, damp, medium dense, silty SAND, little gravel, (F111). 20A1: Brown, damp, medium dense, SAND, same silt, fine to medium sand, (F111). 20B1: Gray-brown, moist, stiff, silty CLAY, blocky structure, (Presumpscot Formation). Similar to above. PP4-0-7.0 ksf	20	24/14	2.80 - 4.80	8/8/7/5	15	23			30	24/24	5.00 - 7.00	3/4/5/6	9	14	40	30A1: Similar to above. 30B1: Gray-brown, moist, stiff, silty CLAY, blocky structure, (Presumpscot Formation). PP4-0-2.5 ksf	40	24/24	10.00 - 12.00	1/1/1/2	2	3	40	40A1: (10.0-10.8 ft): Similar to above except gray and medium stiff to soft. 40B1: 5.0-6.0 ksf 40C1: (10.0-12.0 ft): Gray, wet, medium stiff to soft, silty CLAY, (Presumpscot Formation).	50	24/24	15.00 - 17.00	WBR-12"/WIP-12" Sun=67/27 pcf			50	Gray, wet, soft to medium stiff, silty CLAY, (Presumpscot Formation). 55k10 mm row torque readings: V1: 18.0/1.0 ft-lbs V2: 21.0/2.0 ft-lbs	60	24/24	20.00 - 22.00	WDR/WIP-18"			PROBE	Similar to above. Advanced by hydraulic pushed rod probe from 22 to 21.1 ft bgs. Bottom of Exploration at 21.6 feet below ground surface. Rod Probe Refusal.
Depth (ft.)	Soil No.	Pen./Frac. (ft)	Depth (ft.)	Pen./Frac. (ft)	Soil Description and Remarks	Laboratory Testing Result/AASHTO and Unified Class																																																						
10	24/19	0.80 - 2.80	36/11/9/6	20	31	55A	7.5" of Pavement. 10A1: Gray, damp, dense, gravelly SAND, trace silt, (F111) - (Blow Count). 10B1: 5" of wood at 21.5 ft bgs. 10C1: Brown, damp, medium dense, silty SAND, little gravel, (F111). 20A1: Brown, damp, medium dense, SAND, same silt, fine to medium sand, (F111). 20B1: Gray-brown, moist, stiff, silty CLAY, blocky structure, (Presumpscot Formation). Similar to above. PP4-0-7.0 ksf																																																					
20	24/14	2.80 - 4.80	8/8/7/5	15	23																																																							
30	24/24	5.00 - 7.00	3/4/5/6	9	14	40	30A1: Similar to above. 30B1: Gray-brown, moist, stiff, silty CLAY, blocky structure, (Presumpscot Formation). PP4-0-2.5 ksf																																																					
40	24/24	10.00 - 12.00	1/1/1/2	2	3	40	40A1: (10.0-10.8 ft): Similar to above except gray and medium stiff to soft. 40B1: 5.0-6.0 ksf 40C1: (10.0-12.0 ft): Gray, wet, medium stiff to soft, silty CLAY, (Presumpscot Formation).																																																					
50	24/24	15.00 - 17.00	WBR-12"/WIP-12" Sun=67/27 pcf			50	Gray, wet, soft to medium stiff, silty CLAY, (Presumpscot Formation). 55k10 mm row torque readings: V1: 18.0/1.0 ft-lbs V2: 21.0/2.0 ft-lbs																																																					
60	24/24	20.00 - 22.00	WDR/WIP-18"			PROBE	Similar to above. Advanced by hydraulic pushed rod probe from 22 to 21.1 ft bgs. Bottom of Exploration at 21.6 feet below ground surface. Rod Probe Refusal.																																																					

Maine Department of Transportation Soil/Book Exploration Log US_CUSTOMARY_UNITS		Project: Intersection Improvements and Signalization of Cumberland Mills Location: Westbrook, Maine		Boring No.: HB-WBR-104 WIN: 018637.00																																																								
Driller: S. W. Cole Explorations, LLC	Elevation (ft.): 68.7	Auger ID/00: 5" Solid-Shaft	Operator: M. Leonard	Datum: NAVD83	Sampler: Standard Split Spoon																																																							
Logged By: J. Dubois	Rig Type: Diedrich D-50	Home Wt./Fall: 140W/30"	Drilling Method: Cased Wash	Core Barrel: N/A	Water Level: 27 ft (after drilling)																																																							
Date Start/Finish: 09-11-2018/09-12-2018	Drilling Method: Cased Wash	Core Barrel: N/A	Water Level: 27 ft (after drilling)	Home Efficiency Factor: 0.918	Home Type: Automatic																																																							
Boring Location: 150' EMBR-11-20' L WESTBROOK STREET	Drilling Method: Cased Wash	Core Barrel: N/A	Water Level: 27 ft (after drilling)	Home Efficiency Factor: 0.918	Home Type: Automatic																																																							
<p>Definitions: S = Soil Spoon Sample, SA = Split Stem Auger, SS = Standard Split Spoon Sample Attempt, T = Thin Wall Tube Sample, M = Measured This Well Tube Sample Attempt, V = Field Vane Shear Test, W = Pocket Penetrometer WMC = Weight of Rod or Casing, H = Horizontal Field Shear Test, A = Blow Count, B = Blows per Foot</p> <p>Abbreviations: F = Rock Core Sample, S = Soil Spoon Sample, SA = Split Stem Auger, SS = Standard Split Spoon Sample Attempt, T = Thin Wall Tube Sample, M = Measured This Well Tube Sample Attempt, V = Field Vane Shear Test, W = Pocket Penetrometer WMC = Weight of Rod or Casing, H = Horizontal Field Shear Test, A = Blow Count, B = Blows per Foot</p>																																																												
<table border="1"> <thead> <tr> <th>Depth (ft.)</th> <th>Soil No.</th> <th>Pen./Frac. (ft)</th> <th>Depth (ft.)</th> <th>Pen./Frac. (ft)</th> <th>Soil Description and Remarks</th> <th>Laboratory Testing Result/AASHTO and Unified Class</th> </tr> </thead> <tbody> <tr> <td>10</td> <td>24/6</td> <td>1.00 - 3.00</td> <td>6/11/2/9</td> <td>23</td> <td>35</td> <td></td> <td>8" of Pavement. Brown, damp, dense, gravelly SAND, trace silt, (F111).</td> </tr> <tr> <td>20</td> <td>24/15</td> <td>3.00 - 5.00</td> <td>9/9/10/8</td> <td>19</td> <td>29</td> <td></td> <td>Brown, moist, medium dense, SAND, trace silt, (F111).</td> </tr> <tr> <td>30</td> <td>24/22</td> <td>5.00 - 7.00</td> <td>3/3/3/4</td> <td>6</td> <td>9</td> <td>25</td> <td>30A1: Gray-brown, moist, stiff to very stiff, silty CLAY, blocky structure, (Presumpscot Formation). 30B1: Similar to above. 30C1: (5.0-6.0 ft): Gray, moist, medium stiff, silty CLAY, (Presumpscot Formation). PP4-0-2.5 ksf</td> </tr> <tr> <td>40</td> <td>24/24</td> <td>10.00 - 12.00</td> <td>WBR-12"/WIP-12" Sun=67/27 pcf</td> <td></td> <td></td> <td>40</td> <td>Gray, wet, very soft, silty CLAY, (Presumpscot Formation).</td> </tr> <tr> <td>50</td> <td>24/24</td> <td>15.00 - 17.00</td> <td>WBR-12"/WIP-12" Sun=67/27 pcf</td> <td></td> <td></td> <td>50</td> <td>Gray, wet, very soft to soft, silty CLAY, (Presumpscot Formation). 55k10 mm row torque readings: V1: 14.0/1.0 ft-lbs V2: 16.0/2.0 ft-lbs</td> </tr> <tr> <td>60</td> <td>24/24</td> <td>20.00 - 22.00</td> <td>WDR/WIP-18" Sun=67/27 pcf</td> <td></td> <td></td> <td>PROBE</td> <td>Similar to above, except soft to medium stiff. 55k10 mm row torque readings: V1: 14.0/1.0 ft-lbs V2: 16.0/2.0 ft-lbs Advanced by hydraulic pushed rod probe from 22 to 29.4 ft bgs.</td> </tr> </tbody> </table>						Depth (ft.)	Soil No.	Pen./Frac. (ft)	Depth (ft.)	Pen./Frac. (ft)	Soil Description and Remarks	Laboratory Testing Result/AASHTO and Unified Class	10	24/6	1.00 - 3.00	6/11/2/9	23	35		8" of Pavement. Brown, damp, dense, gravelly SAND, trace silt, (F111).	20	24/15	3.00 - 5.00	9/9/10/8	19	29		Brown, moist, medium dense, SAND, trace silt, (F111).	30	24/22	5.00 - 7.00	3/3/3/4	6	9	25	30A1: Gray-brown, moist, stiff to very stiff, silty CLAY, blocky structure, (Presumpscot Formation). 30B1: Similar to above. 30C1: (5.0-6.0 ft): Gray, moist, medium stiff, silty CLAY, (Presumpscot Formation). PP4-0-2.5 ksf	40	24/24	10.00 - 12.00	WBR-12"/WIP-12" Sun=67/27 pcf			40	Gray, wet, very soft, silty CLAY, (Presumpscot Formation).	50	24/24	15.00 - 17.00	WBR-12"/WIP-12" Sun=67/27 pcf			50	Gray, wet, very soft to soft, silty CLAY, (Presumpscot Formation). 55k10 mm row torque readings: V1: 14.0/1.0 ft-lbs V2: 16.0/2.0 ft-lbs	60	24/24	20.00 - 22.00	WDR/WIP-18" Sun=67/27 pcf			PROBE	Similar to above, except soft to medium stiff. 55k10 mm row torque readings: V1: 14.0/1.0 ft-lbs V2: 16.0/2.0 ft-lbs Advanced by hydraulic pushed rod probe from 22 to 29.4 ft bgs.
Depth (ft.)	Soil No.	Pen./Frac. (ft)	Depth (ft.)	Pen./Frac. (ft)	Soil Description and Remarks	Laboratory Testing Result/AASHTO and Unified Class																																																						
10	24/6	1.00 - 3.00	6/11/2/9	23	35		8" of Pavement. Brown, damp, dense, gravelly SAND, trace silt, (F111).																																																					
20	24/15	3.00 - 5.00	9/9/10/8	19	29		Brown, moist, medium dense, SAND, trace silt, (F111).																																																					
30	24/22	5.00 - 7.00	3/3/3/4	6	9	25	30A1: Gray-brown, moist, stiff to very stiff, silty CLAY, blocky structure, (Presumpscot Formation). 30B1: Similar to above. 30C1: (5.0-6.0 ft): Gray, moist, medium stiff, silty CLAY, (Presumpscot Formation). PP4-0-2.5 ksf																																																					
40	24/24	10.00 - 12.00	WBR-12"/WIP-12" Sun=67/27 pcf			40	Gray, wet, very soft, silty CLAY, (Presumpscot Formation).																																																					
50	24/24	15.00 - 17.00	WBR-12"/WIP-12" Sun=67/27 pcf			50	Gray, wet, very soft to soft, silty CLAY, (Presumpscot Formation). 55k10 mm row torque readings: V1: 14.0/1.0 ft-lbs V2: 16.0/2.0 ft-lbs																																																					
60	24/24	20.00 - 22.00	WDR/WIP-18" Sun=67/27 pcf			PROBE	Similar to above, except soft to medium stiff. 55k10 mm row torque readings: V1: 14.0/1.0 ft-lbs V2: 16.0/2.0 ft-lbs Advanced by hydraulic pushed rod probe from 22 to 29.4 ft bgs.																																																					

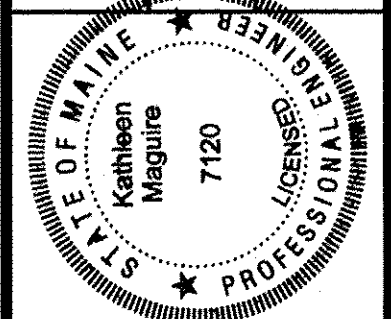

PROJ. MANAGER: [Signature]
DATE: 2/13/2020
SIGNATURE: [Signature]
DATE: 2/13/2020
P.E. NUMBER: [Blank]
DATE: [Blank]

DATE	BY	REVISIONS
7/20	WHITE	DESIGN-DETAILED
		CHECKED-REVIEWED
		DESIGN-DETAILED
		DESIGN-DETAILED
		REVISIONS 1
		REVISIONS 2
		REVISIONS 3
		REVISIONS 4
		FIELD CHANGES

WESTBROOK
CUMBERLAND ROTARY
BORING LOGS

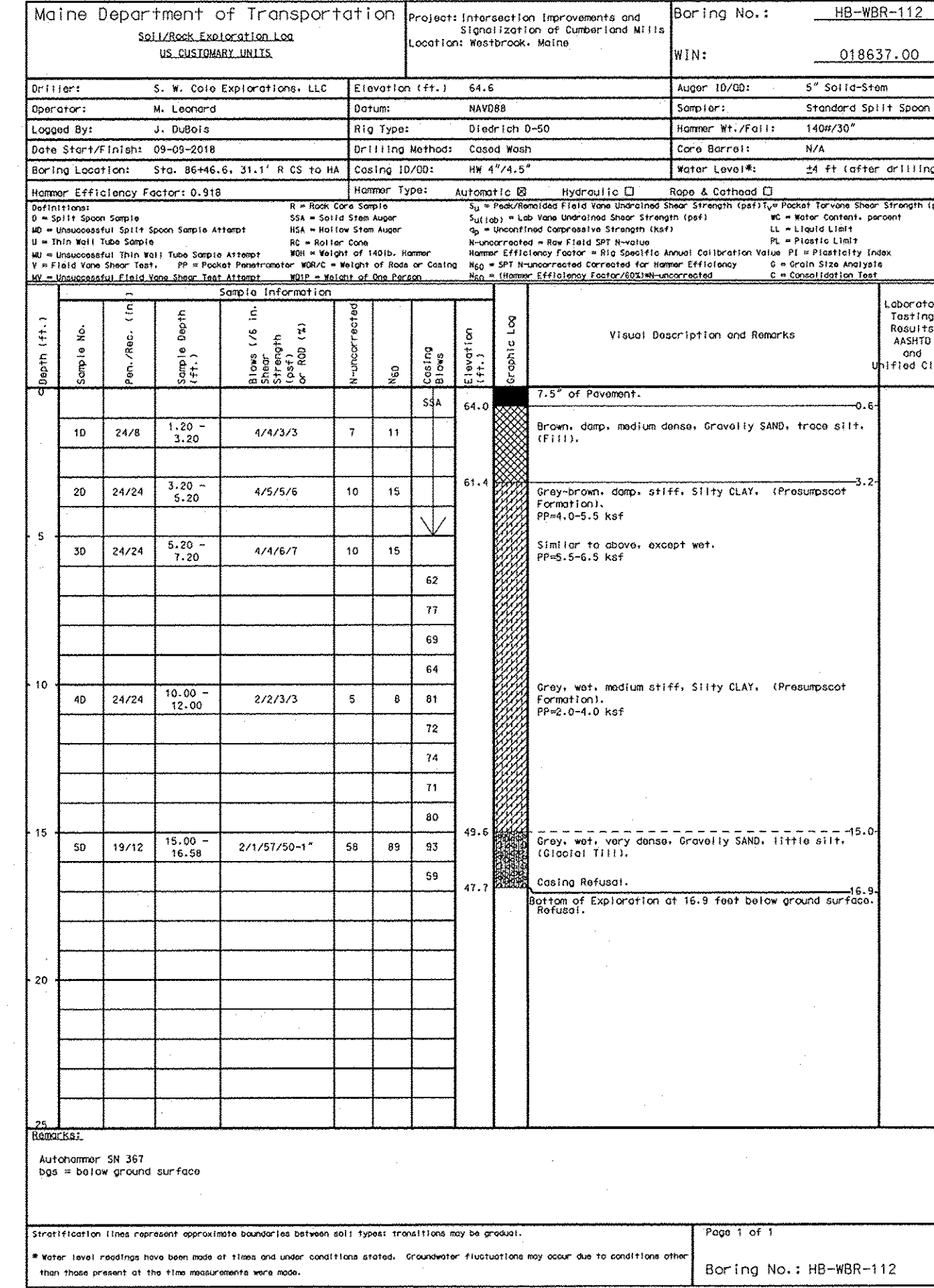
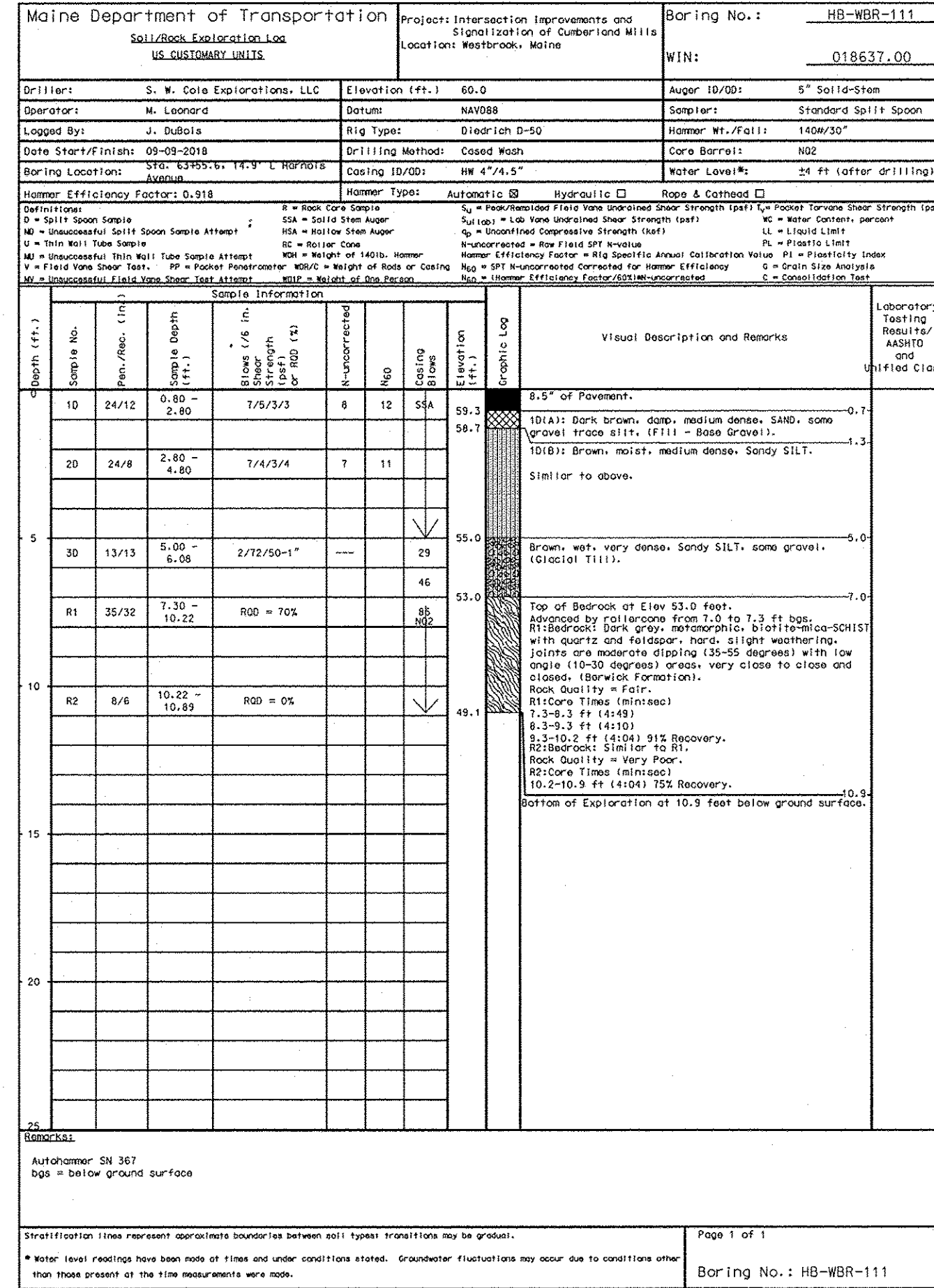
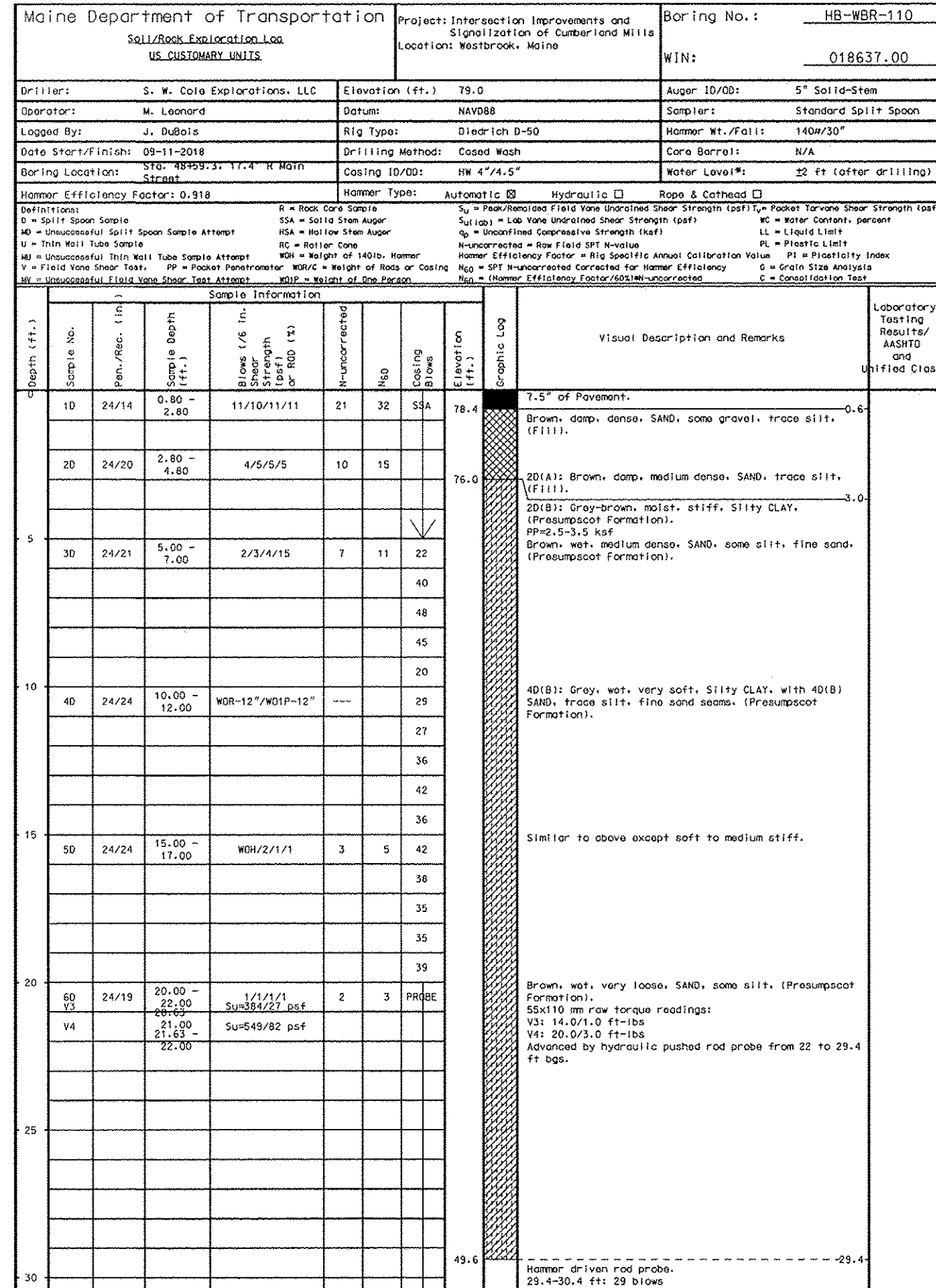
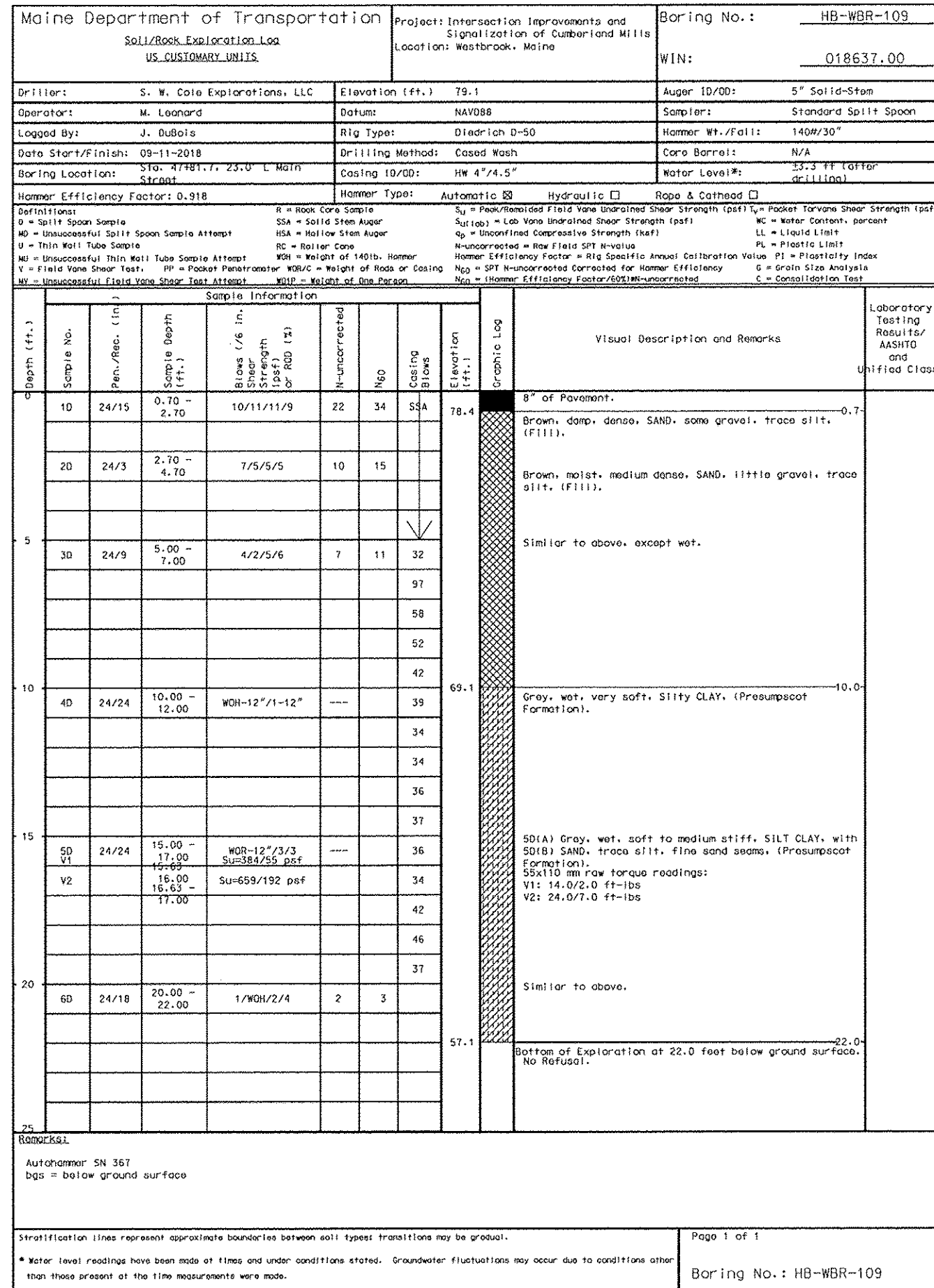

STATE OF MAINE
DEPARTMENT OF TRANSPORTATION
STP-1863(700)

WESTBROOK
CUMBERLAND ROTARY
BORING LOGS

SHEET NUMBER
28
OF 53

HIGHWAY PLANS
WIN
018637.00

PROJ. MANAGER: _____ DATE: _____

DESIGN-DETAILED: _____

CHECKED-REVIEWED: _____

DESIGN-DETAILED2: K.MAGUIRE T.WHITE FEB 2020

DESIGN-DETAILED3: _____

REVISIONS: 1

REVISIONS: 2

REVISIONS: 3

REVISIONS: 4

FIELD CHANGES

Signature: _____
KATHLEEN MAGUIRE
Professional Engineer
License No. 7120
Date: 2/13/2020

Identification Number	Size of Sign		Text	Text Dimensions (Inches)			Number of Signs Required	Color		Border Radius	Area in Square Feet	Post
	Width	Height		Letter Height	Vertical Spacing	Arrow RTE.MKR.		Back-ground	Legend Border			
MI-5(25)	24"	24"		SHSB	SHSB	SHSB	8	WHITE	BLACK	SHSB	4.00 (32.00)	U-CHANNEL POST
M3-2	24"	12"					4	WHITE	BLACK		2.00 (8.00)	MOUNT ABOVE M4-3
M3-4	24"	12"					4	WHITE	BLACK		2.00 (8.00)	MOUNT ABOVE M4-3
M4-3	24"	12"					8	WHITE	BLACK		2.00 (16.00)	MOUNT ABOVE MI-5(25)
M5-4	24"	18"					2	WHITE	BLACK		3.00 (6.00)	MOUNT BELOW MI-5(25)
M5-6	24"	18"					2	WHITE	BLACK		3.00 (6.00)	MOUNT BELOW MI-5(25)
M6-3	21"	15"					2	WHITE	BLACK		2.19 (4.38)	MOUNT BELOW MI-5(25)
R1-1	30"	30"					1	RED	WHITE		6.25 (25.00)	U-CHANNEL POST
R2-1(25)	24"	30"					2	WHITE	BLACK		5.00 (15.00)	MOUNT TO SIGN SUPPORT UPRIGHT
							1					U-CHANNEL POST
R3-2	24"	24"					3	WHITE	BLACK		4.00 (12.00)	MOUNT TO MAST ARM UPRIGHT
R3-5a	30"	36"					4	WHITE	BLACK		7.50 (30.00)	MOUNT TO MAST ARMS
R3-5L	30"	36"					5	WHITE	BLACK		7.50 (37.50)	MOUNT TO MAST ARMS
R3-5R	30"	36"					6	WHITE	BLACK		7.50 (45.00)	MOUNT TO MAST ARMS
R3-6L	30"	36"					2	WHITE	BLACK		7.50 (15.00)	MOUNT TO MAST ARMS
R3-6R	30"	36"					3	WHITE	BLACK		7.50 (22.50)	MOUNT TO MAST ARMS

SHSB - Text Dimensions Shall Conform to "Standard Highway Signs Book" - 2012 Edition.

Identification Number	Size of Sign		Text	Text Dimensions (Inches)			Number of Signs Required	Color		Border Radius	Area in Square Feet	Post
	Width	Height		Letter Height	Vertical Spacing	Arrow RTE.MKR.		Back-ground	Legend Border			
R3-8	42"	30"		SHSB	SHSB	SHSB	1	WHITE	BLACK	SHSB	8.75 (8.75)	2 U-CHANNEL POSTS
R3-8	42"	30"					1	WHITE	BLACK		8.75 (8.75)	2 U-CHANNEL POSTS
R3-8	36"	30"					1	WHITE	BLACK		7.50 (7.50)	U-CHANNEL POST
R3-8	36"	30"					1	WHITE	BLACK		7.50 (7.50)	U-CHANNEL POST
R4-7	24"	30"					4	BLACK	WHITE		3.00 (6.00)	U-CHANNEL POST
R4-11	30"	30"					4	WHITE	BLACK		6.25 (25.00)	U-CHANNEL POST
R5-1	30"	30"					1	WHITE	RED		6.25 (6.25)	U-CHANNEL POST
R6-1R	36"	12"					5	BLACK	WHITE		3.00 (15.00)	U-CHANNEL POST
R6-1L	36"	12"					2	BLACK	WHITE		3.00 (9.00)	MOUNT BACK TO BACK WITH R6-1R
							1					U-CHANNEL POST
R7-1	12"	18"					2	WHITE	RED		1.50 (3.00)	U-CHANNEL POST
R7-1L	12"	18"					1	WHITE	RED		1.50 (1.50)	U-CHANNEL POST
R7-108	12"	18"					2	WHITE	GREEN		1.50 (3.00)	U-CHANNEL POST
R10-12	30"	36"					2	WHITE	BLACK		7.50 (15.00)	MOUNT TO MAST ARM
R10-15	30"	30"					4	WHITE / YELLOW	BLACK / RED		6.25 (25.00)	MOUNT TO MAST ARM
R10-15R	30"	30"					1	WHITE / YELLOW	BLACK / RED		6.25 (25.00)	U-CHANNEL POST
							3					MOUNT TO MAST ARM
R15-1	48"	9"					4	WHITE	BLACK		6.00 (24.00)	POST WITH RETROREFLECTIVE STRIPS

SHSB - Text Dimensions Shall Conform to "Standard Highway Signs Book" - 2012 Edition.



PROJ. MANAGER	B. KEEZER	BY	DATE
DESIGN-DETAILED	MJC	JAR	04/19
CHECKED-REVIEWED	MOS	CMB	04/19
DESIGNS-DETAILED			
DESIGNS-DETAILED			
REVISIONS 1			
REVISIONS 2			
REVISIONS 3			
REVISIONS 4			
FIELD CHANGES			

SIGNALIZATION OF
CUMBERLAND MILLS ROTARY
SIGN SUMMARY SHEET
(1 OF 2)

SHEET NUMBER

29

Identification Number	Size of Sign		Text	Text Dimensions (Inches)			Number of Signs Required	Color		Border Radius	Area in Square Feet	Post
	Width	Height		Letter Height	Vertical Spacing	Arrow RTE.MKR.		Back-ground	Legend Border			
GS-1	30"	48"		5D 5D 5D 5D	5.6" 4" 4" 5.6"		1	YELLOW	BLACK	1.5"	10.00 (10.00)	MOUNT TO MAST ARM
GS-2	84"	54"		6D 8/6D 8/6D	5.6" 6" 5.5" 4.7"	12"x8.2"	1	GREEN	WHITE	3"	31.50 (31.50)	MOUNT TO MAST ARM
GS-3	48"	60"		5B 8/6D	7" 3" 3" 4.8"	9"x6.2"	1	GREEN	WHITE	3"	20.00 (20.00)	MOUNT TO MAST ARM
GS-4	72"	12"		6/4.5C	3" 3"	6"x9"	1	GREEN	WHITE	1"	6.00 (6.00)	2 U-CHANNEL POSTS
GS-5	60"	60"		8/6D 7/6D	6" 3" 3" 5"	12"x8.2"	3	GREEN	WHITE	3"	25.00 (25.00)	MOUNT TO MAST ARM
GS-6	66"	24"		6/4.5D, 5D	4.5" 4" 3.3"	9"x6.2"	2	GREEN	WHITE	1.75"	11.00 (11.00)	MOUNT TO MAST ARM
GS-7	54"	24"		6/4.5D	4" 4" 4"	6"x9"	1	GREEN	WHITE	1.75"	9.00 (9.00)	MOUNT TO MAST ARM
GS-8	66"	24"		6/4.5D 5D	4" 5.5" 3.5"		1	GREEN	WHITE	1.75"	11.00 (11.00)	2 U-CHANNEL POSTS
GS-9	48"	48"		6D 6D 6D	4.5" 5" 5" 4.5"	6"x9"	1	YELLOW	BLACK	3"	16.00 (16.00)	MOUNT TO MAST ARM
GS-10	78"	30"		6D, 8/6D	6.2" 4.9" 4.7"	9"x6.2"	1	GREEN	WHITE	2.25"	16.25 (16.25)	MOUNT TO MAST ARM
GS-11	60"	60"		8/6D 7/6D	6" 3" 3" 5"	12"x8.2"	1	GREEN	WHITE	3"	25.00 (25.00)	MOUNT TO MAST ARM

SHSB - Text Dimensions Shall Conform to "Standard Highway Signs Book" - 2012 Edition.

Identification Number	Size of Sign		Text	Text Dimensions (Inches)			Number of Signs Required	Color		Border Radius	Area in Square Feet	Post
	Width	Height		Letter Height	Vertical Spacing	Arrow RTE.MKR.		Back-ground	Legend Border			
D3-1a	42"	12"		6/4.5D	3" 3"		1	GREEN	WHITE	1"	3.50 (3.50)	U-CHANNEL POST DOUBLE SIDED
D3-1b	48"	18"		8/6D	6" 6"		1	GREEN	WHITE	1.5"	6.00 (6.00)	MOUNT TO MAST ARM
D3-1c	54"	18"		8/6D	6" 6"		1	GREEN	WHITE	1.5"	6.75 (6.75)	MOUNT TO MAST ARM
D3-1d	60"	18"		8/6D	6" 6"		1	GREEN	WHITE	1.5"	7.50 (7.50)	MOUNT TO MAST ARM
D3-1e	84"	18"		8/6D	6" 6"		1	GREEN	WHITE	1.5"	10.50 (10.50)	MOUNT TO MAST ARM
D3-1f	66"	18"		8/6D	6" 6"		1	GREEN	WHITE	1.5"	8.25 (8.25)	MOUNT TO MAST ARM
D3-1g	42"	12"		6/4.5D	3" 3"		1	GREEN	WHITE	1"	3.50 (3.50)	MOUNT ABOVE RI-1
W3-3	36"	36"		SHSB	SHSB	SHSB	3	YELLOW	BLACK	SHSB	9.00 (27.00)	U-CHANNEL POST
W4-2L	36"	36"					1	YELLOW	BLACK		9.00 (9.00)	U-CHANNEL POST
W10-1	36" DIA						1	YELLOW	BLACK		7.10 (7.10)	U-CHANNEL POST
W10-9P	30"	24"					1	YELLOW	BLACK		5.00 (5.00)	MOUNT BELOW W10-1
W11-2	30"	30"					2	FLUORESCENT YELLOW	BLACK		6.25 (12.50)	MOUNT TO PEDESTAL POLE/U-CHANNEL POST
W12-1	36"	36"					4	YELLOW	BLACK		9.00 (36.00)	U-CHANNEL POST
W16-7PR	24"	12"					1	FLUORESCENT YELLOW	BLACK		2.00 (2.00)	MOUNT BELOW W11-2
W16-7PL	24"	12"					1	FLUORESCENT YELLOW	BLACK		2.00 (2.00)	MOUNT BELOW W11-2

SHSB - Text Dimensions Shall Conform to "Standard Highway Signs Book" - 2012 Edition.

STATE OF MAINE
DEPARTMENT OF TRANSPORTATION

PROJECT NO. STP-1863(700)
HIGHWAY PLANS

WIN
18637.00

PROJ. MANAGER	B. KEEZER	DATE
DESIGN DETAILED	MJC	04/19
CHECKED/REVIEWED	JAR	04/19
DESIGNS DETAILED	CMB	
DESIGNS DETAILED		
REVISIONS 1		
REVISIONS 2		
REVISIONS 3		
REVISIONS 4		
FIELD CHANGES		

SIGNALIZATION OF
 CUMBERLAND MILLS ROTARY
 SIGN SUMMARY SHEET
 (2 OF 2)

SHEET NUMBER
30

OF 53

LIST OF MAJOR ITEMS

EQUIPMENT AND WORK ITEMS	QUANTITY
FURNISH AND INSTALL 48-INCH DIAMETER, 54-INCH DIAMETER, 60-INCH DIAMETER FOUNDATIONS (ITEM 626.333)	26 CY
FURNISH AND INSTALL GALVANIZED STEEL MAST ARM POLE PAINTED BLACK WITH 45-FOOT SIGN ARM (ITEM 643.91)	3
FURNISH AND INSTALL GALVANIZED STEEL MAST ARM POLE PAINTED BLACK WITH 50-FOOT SIGN ARM (ITEM 643.91)	1

THE LISTED QUANTITIES ARE APPROXIMATE AND ARE FURNISHED FOR INFORMATION ONLY.

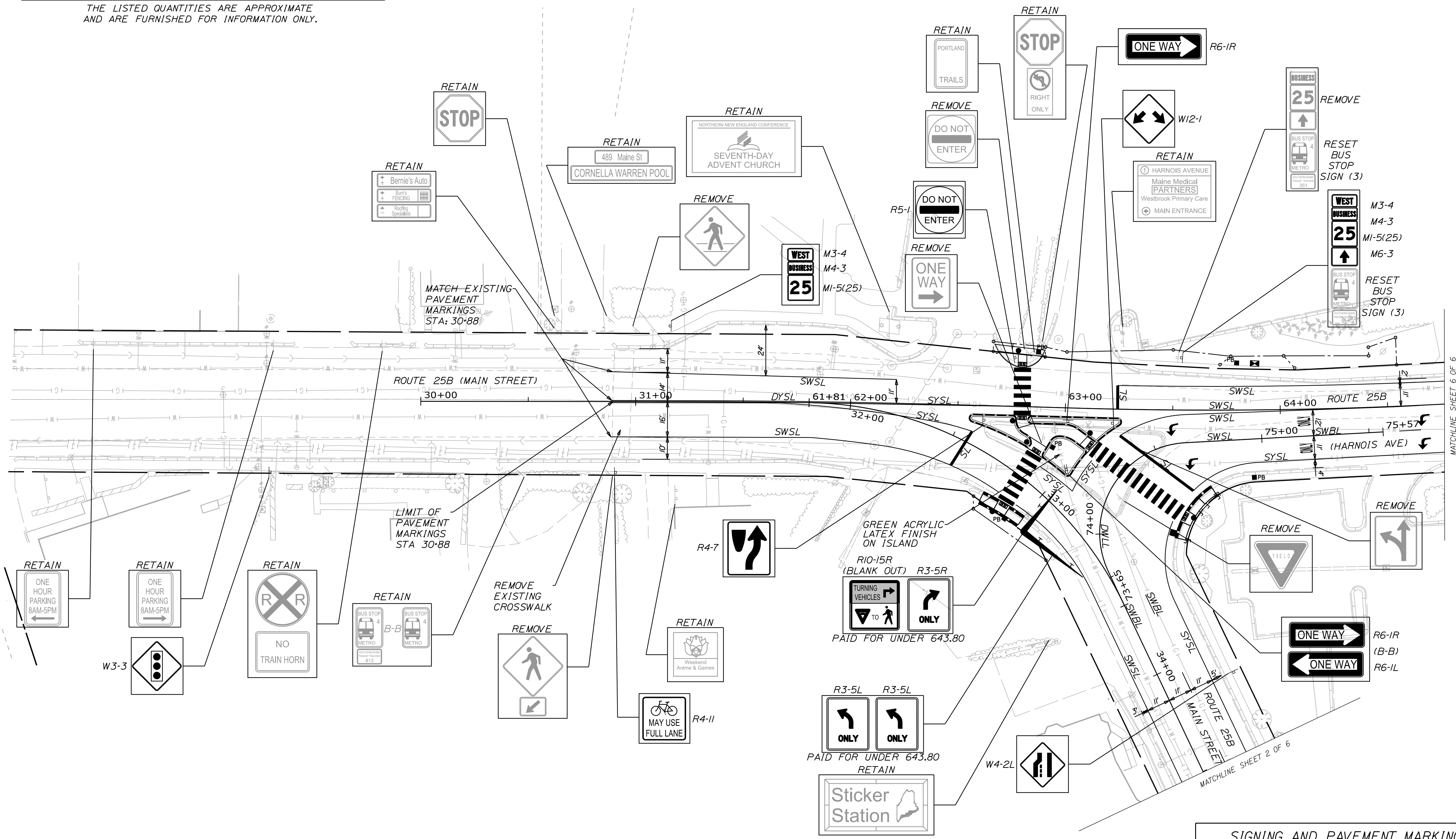
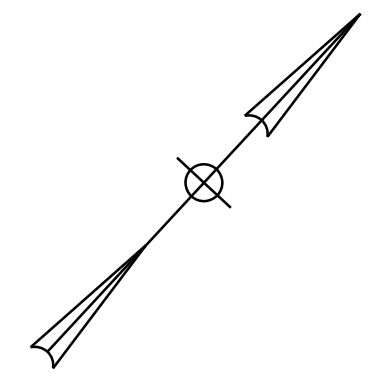

SIGNALING AND PAVEMENT MARKING LEGEND

- SWSL - SINGLE WHITE SOLID LINE
- SWBL - SINGLE WHITE BROKEN LINE (10' LINE 30' SPACE)
- SYSL - SINGLE YELLOW SOLID LINE
- DYSL - DOUBLE YELLOW SOLID LINE
- SL - SINGLE SOLID LINE - STOPLINE (12')
- DWLL - DOTTED WHITE LANE LINE WITH TAPE (3' LINE 9' SPACE)
- ☞ - WHITE PAVEMENT MARKING SYMBOLS (SEE NOTE 5)

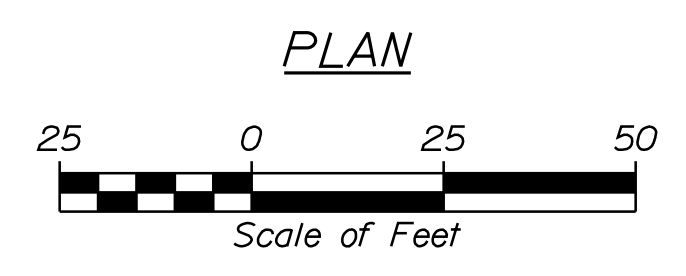

Filename: ... \MSTA031_SignStripe_1.dgn
 Division: HIGHWAY
 Username: jrobert
 Date: 2/17/2020

STATE OF MAINE DEPARTMENT OF TRANSPORTATION PROJECT NO. STP-1863(700) WIN 18637.00 HIGHWAY PLANS
SIGNALIZATION OF CUMBERLAND MILLS ROTARY SIGNING AND STRIPING PLANS (1 OF 6)
SHEET NUMBER 31 OF 53

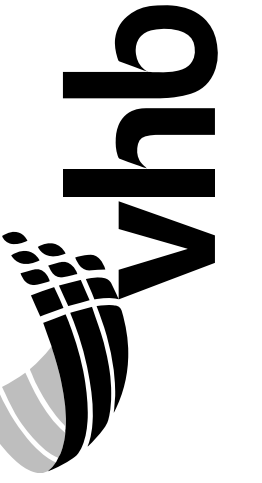
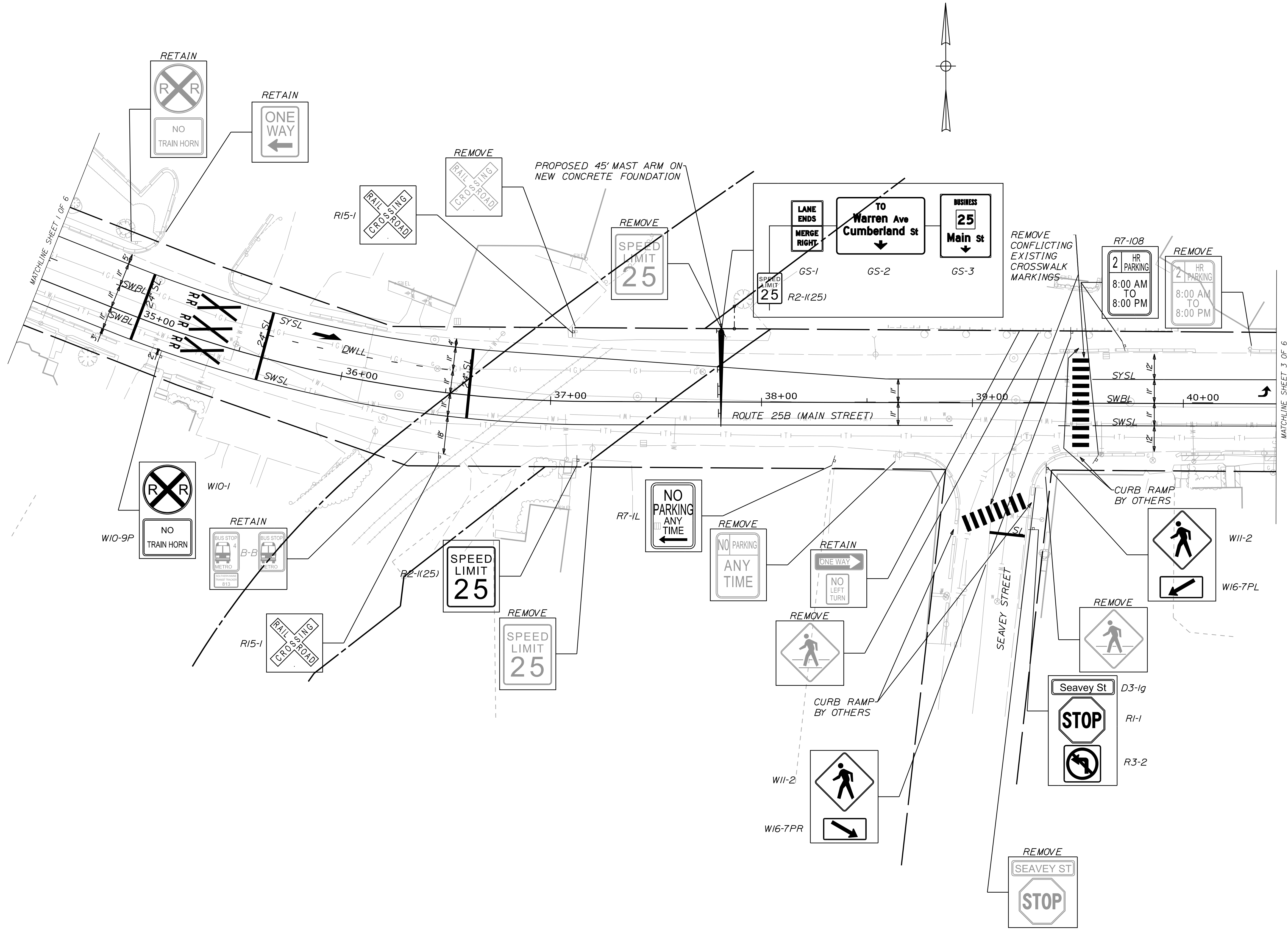
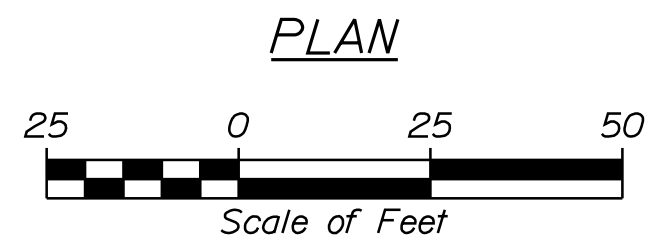

PROJ. MANAGER	B. KEEZER	BY	DATE
DESIGN DETAILED	MLC	JAR	04/19
CHECKED/REVIEWED	MOS	CMB	04/19
DESIGN DETAILED			
DESIGN DETAILED			
REVISIONS 1			
REVISIONS 2			
REVISIONS 3			
REVISIONS 4			
FIELD CHANGES			

SIGNALIZATION OF
CUMBERLAND MILLS ROTARY
SIGNING AND STRIPING
PLANS (2 OF 6)

SHEET NUMBER

32

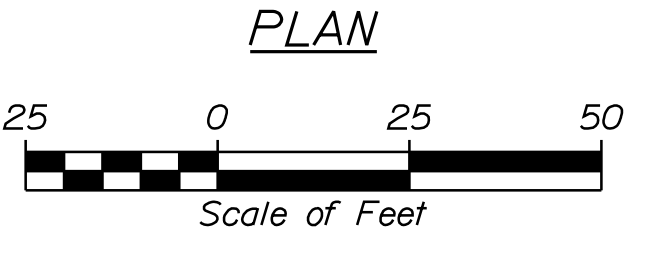
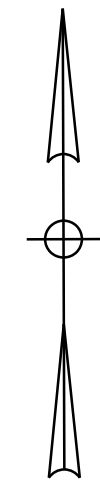
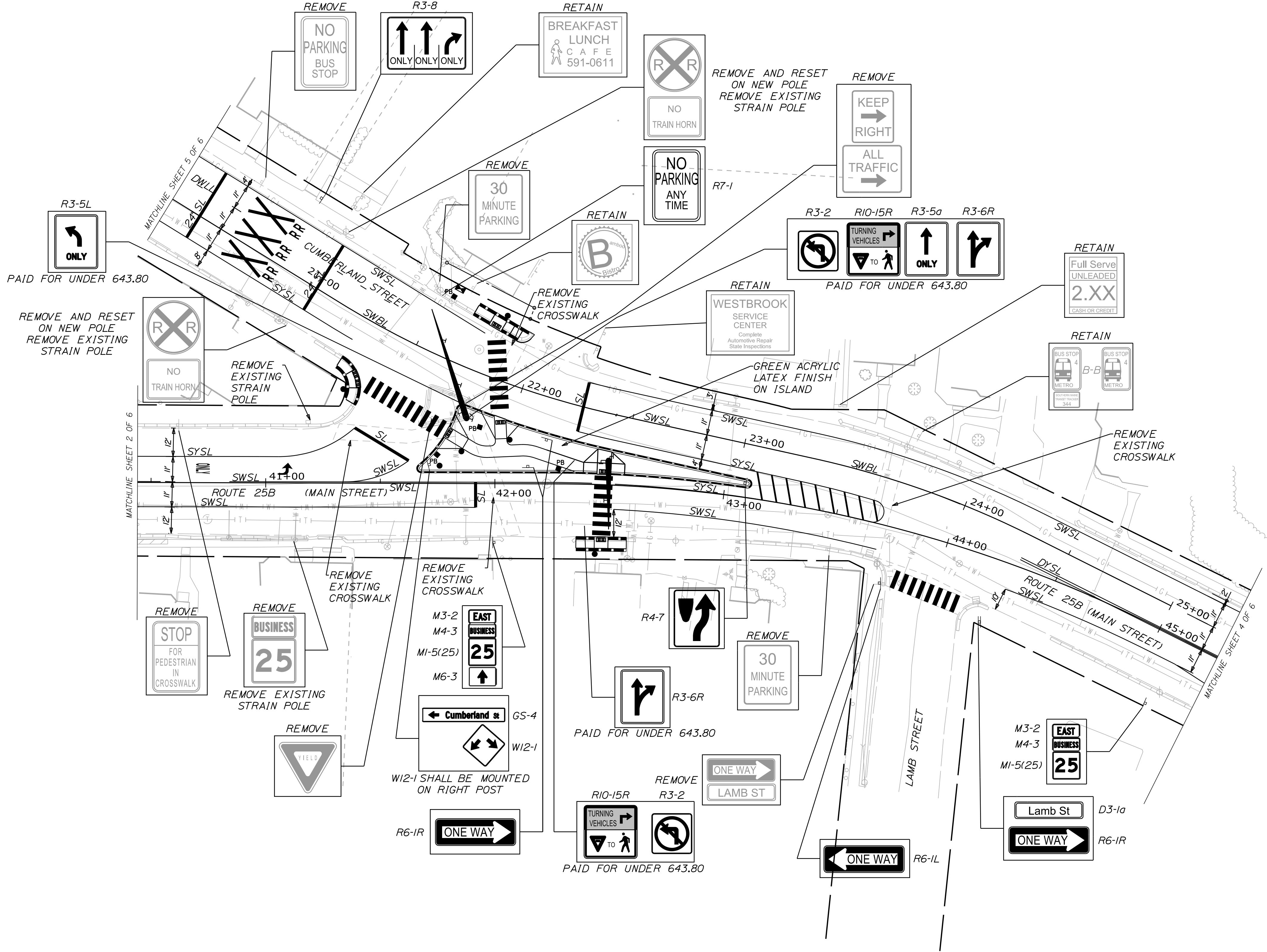

PROJ. MANAGER	B. KEEZER	BY	DATE
DESIGN DETAILED	MJC	JAR	04/19
CHECKED-REVIEWED	MOS	CMB	04/19
DESIGNS DETAILED			
REVISIONS 1			
REVISIONS 2			
REVISIONS 3			
REVISIONS 4			
FIELD CHANGES			

SIGNALIZATION OF
CUMBERLAND MILLS ROTARY
SIGNING AND STRIPING
PLANS (3 OF 6)

Date: 2/17/2020

Username: jrobert

Division: HIGHWAY

Filename: ... \MSTA\034_SignStripe_4.dgn

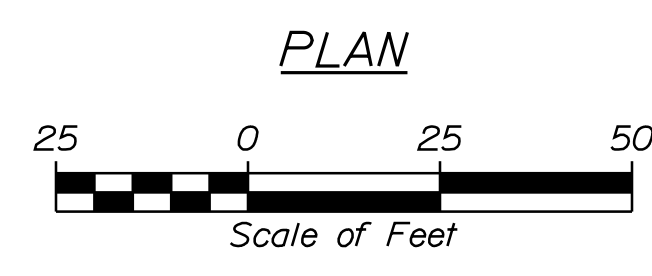
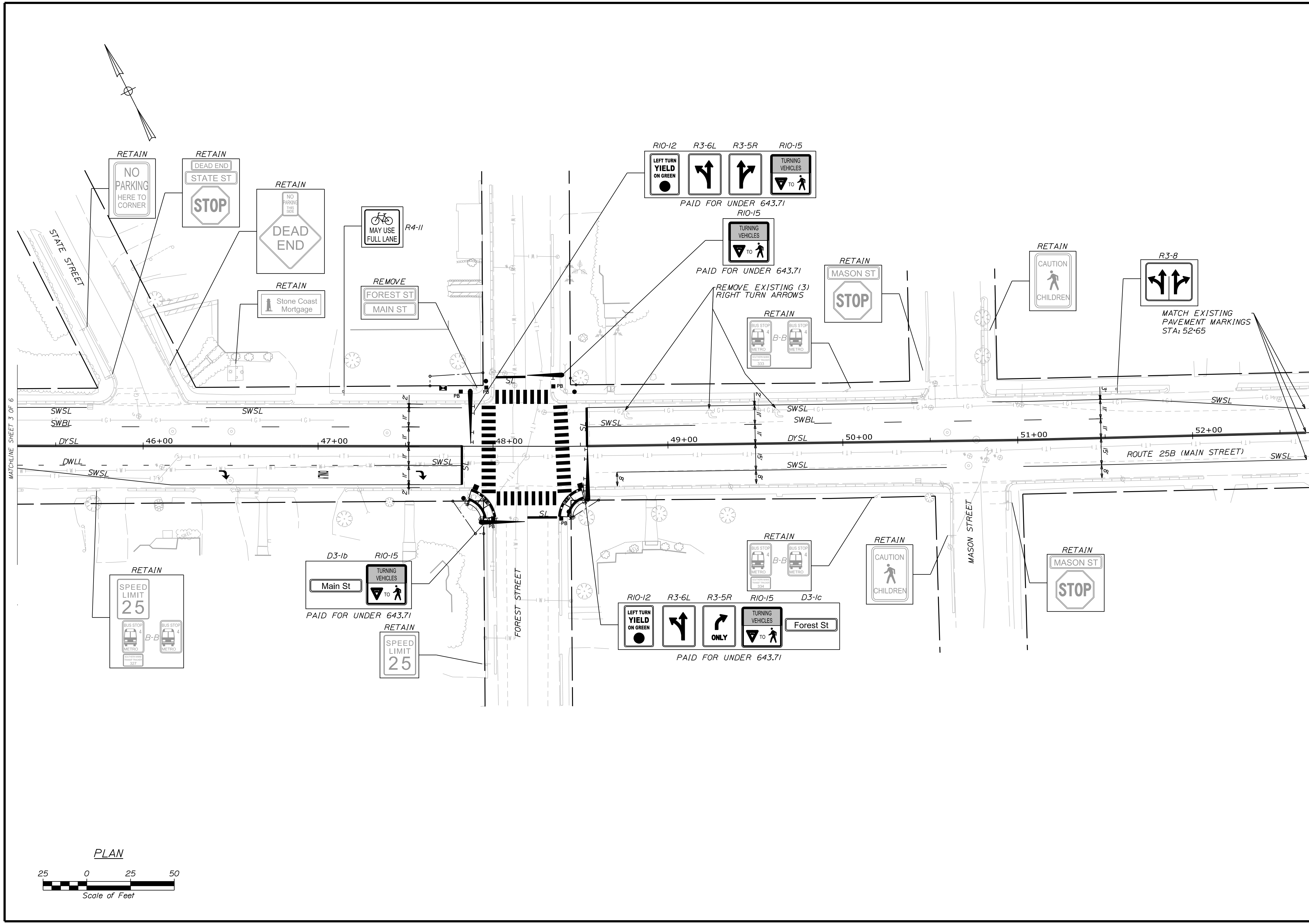

STATE OF MAINE
 DEPARTMENT OF TRANSPORTATION
 PROJECT NO. STP-1863(700)



PROJ. MANAGER	B. KEIZER	DATE
DESIGN DETAILED	MLC	04/19
CHECKED/REVIEWED	JAR	04/19
DESIGN DETAILED	CMB	
DESIGN DETAILED		
REVISIONS 1		
REVISIONS 2		
REVISIONS 3		
REVISIONS 4		
FIELD CHANGES		

SIGNALIZATION OF
 CUMBERLAND MILLS ROTARY
 SIGNING AND STRIPING
 PLANS (4 OF 6)

SHEET NUMBER
34
 OF 53

WIN
 18637.00
 HIGHWAY PLANS

Date: 2/17/2020

Username: jrobert

Division: HIGHWAY

Filename: ... \MSTA\036_SignStripe_6.dgn

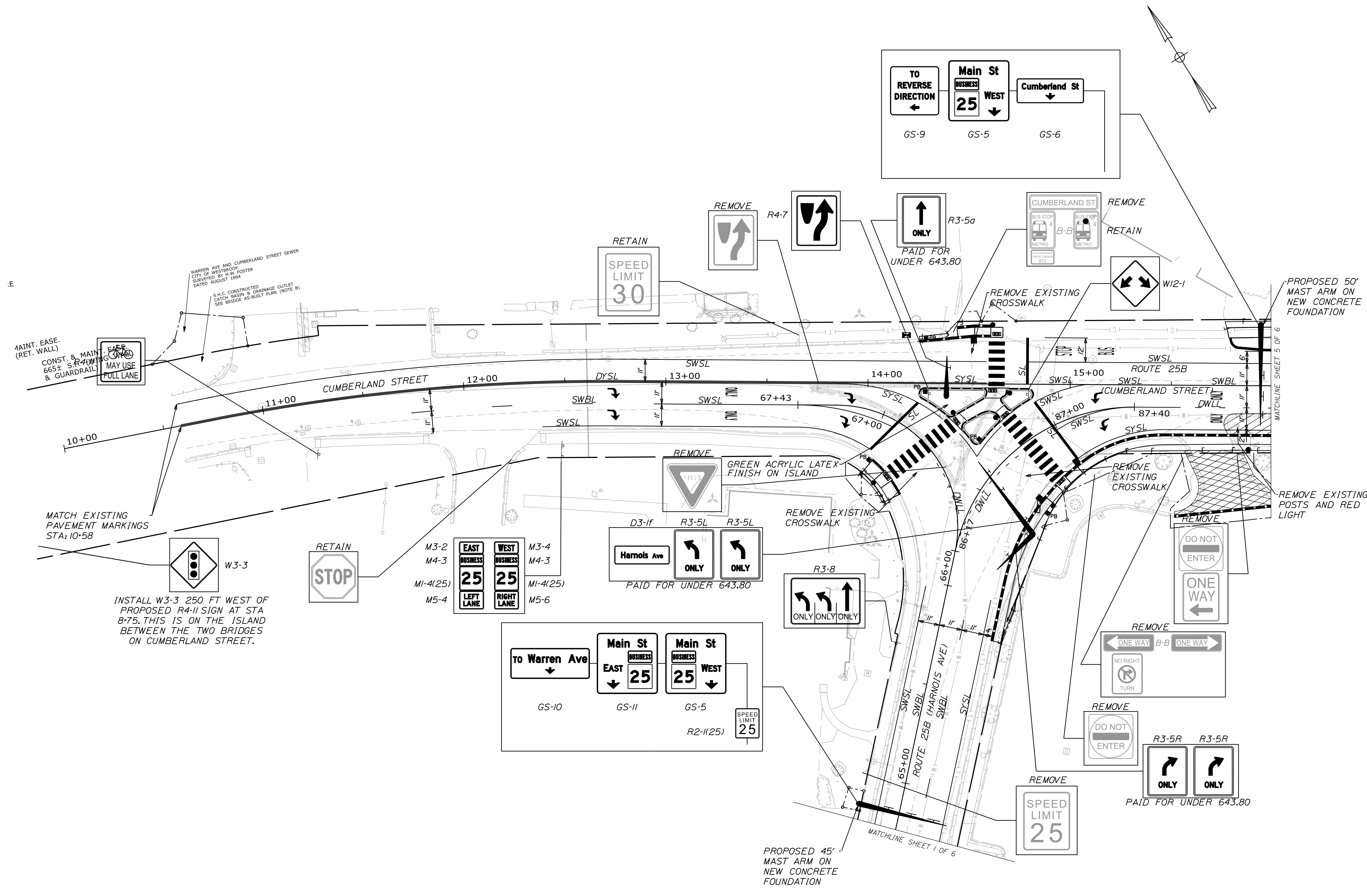

PLAN

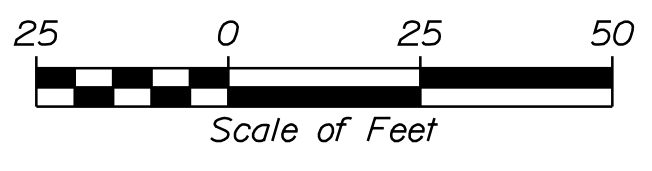

PROJ. MANAGER	DATE	BY	DATE
DESIGN-DETAILED	04/19	JAR	04/19
CHECKED-REVIEWED	MIS	CMB	04/19
DESIGN-DETAILED			
DESIGN-DETAILED			
REVISIONS 1			
REVISIONS 2			
REVISIONS 3			
REVISIONS 4			
FIELD CHANGES			

SIGNALIZATION OF
 CUMBERLAND MILLS ROTARY
 SIGNING AND STRIPING
 PLANS (6 OF 6)

SHEET NUMBER

36

OF 53

SIGNAL PLAN NOTES:

1. THE CONTRACTOR SHALL MEET ALL REQUIREMENTS OF THE UTILITY COMPANIES WHEN INSTALLING EQUIPMENT ON THEIR POLES. THE CONTRACTOR SHALL BE RESPONSIBLE FOR CONTACTING THE UTILITY COMPANIES TO DETERMINE THEIR REQUIREMENTS.
2. THE LOCATIONS OF ALL EQUIPMENT SHOWN ARE APPROXIMATE. FINAL LOCATIONS SHALL BE DETERMINED IN THE FIELD BY THE CONSTRUCTION MANAGER.
3. THE COST OF POLE RISERS SHALL BE INCIDENTAL TO ITEM 643.90.
4. THE COST OF OVERHEAD SIGNS ON THE MAST ARMS SHALL BE INCIDENTAL TO ITEM 643.71 OR ITEM 643.80, AS APPLICABLE.
5. THE CONTRACTOR SHALL BE RESPONSIBLE FOR FINAL STRUCTURAL DESIGN OF THE MAST ARMS AND THE CONNECTION OF THE MAST ARMS TO THEIR FOUNDATIONS. ALL DESIGNS SHALL BE PREPARED AND STAMPED BY A PROFESSIONAL ENGINEER LICENSED IN THE STATE OF MAINE. DESIGN COMPUTATIONS, INCLUDING DESIGN LOADS (OVERTURNING MOMENT, TORSION, SHEAR FORCE AND AXIAL LOAD) AT THE TOP OF THE FOUNDATIONS, AND SHOP DRAWINGS SHALL BE SUBMITTED FOR APPROVAL BY THE DEPARTMENT. NO MATERIALS SHALL BE ORDERED OR FABRICATED UNTIL THE DESIGN HAS BEEN APPROVED.
6. FOUNDATIONS SHALL CONSIST OF CAST-IN-PLACE REINFORCED CONCRETE DRILLED SHAFTS: ONE NEW DRILLED SHAFT PER MAST ARM OR DUAL PURPOSE POLE AS SET FORTH IN SPECIAL PROVISION 643. FOUNDATION SIZES SHALL BE SELECTED BY THE CONTRACTOR BASED UPON ACTUAL COMPUTED BENDING MOMENTS AND TORSION IN ACCORDANCE WITH SPECIAL PROVISION 643. ACTUAL DESIGN LOADS AT THE TOP OF THE FOUNDATION THAT ARE PROVIDED BY THE CONTRACTOR AS PART OF THEIR STRUCTURAL SUBMITTAL WILL BE USED BY THE DEPARTMENT TO CHECK THE SPECIFIED SIZE OF THE DRILLED SHAFTS. A BORING WAS TAKEN AS PART OF THIS PROJECT FOR THE FOUNDATION DESIGN. THE BORING LOCATIONS AND LOG CAN BE FOUND ON THE BORING LOCATION PLANS WITH FOUNDATION DESIGN REQUIREMENTS.
7. WHERE NOTED ON THE PLANS, ALL NEW VEHICULAR SIGNAL HEADS SHALL BE EQUIPPED WITH NEW LED LENSES 12 INCHES IN DIAMETER AND EQUIPPED WITH NEW 5-INCH LOUVERED BACK PLATES, INCLUDING RETROREFLECTIVITY.
8. TWO COPIES OF AS-BUILT PLANS, WIRING DIAGRAMS, BOX PRINTS, AND EQUIPMENT MANUALS SHALL BE LEFT IN EACH OF THE CONTROLLER CABINETS.
9. TRAFFIC SIGNAL WORK SHALL BE COMPLETED IN A MANNER AND ORDER THAT WILL CAUSE THE MINIMUM DISRUPTION TO TRAFFIC.
10. ALL MATERIAL SCHEDULES SHOWN ON THE PLANS ARE FOR GENERAL INFORMATION ONLY. THE CONTRACTOR SHALL PREPARE HIS OWN MATERIAL SCHEDULES BASED UPON HIS PLAN REVIEW. ALL SCHEDULES SHALL BE VERIFIED IN THE FIELD BY THE CONTRACTOR PRIOR TO ORDERING MATERIALS OR PERFORMING WORK.
11. ALL NON-PAVED AREAS DISTURBED DURING CONSTRUCTION SHALL BE LOAMED AND SEEDED, UNLESS OTHERWISE DIRECTED BY THE OWNER. ALL PAVED AREAS DISTURBED DURING CONSTRUCTION SHALL BE REPAIRED BY THE CONTRACTOR. COSTS FOR REPAIR OF DISTURBED AREAS SHALL BE INCIDENTAL TO OTHER CONTRACT ITEMS.
12. CONTRACTOR FURNISHED EQUIPMENT-THE TRAFFIC SIGNAL CONTROLLERS AND VARIOUS OTHER EQUIPMENT ITEMS SHOWN ON THE PLANS SHALL BE FURNISHED AND INSTALLED BY THE CONTRACTOR. PER PORTLAND AREA COMPREHENSIVE TRANSPORTATION SYSTEMS (PACTS) REGIONAL TRANSPORTATION MANAGEMENT SYSTEMS (RTMS) SPECIFICATIONS, THE TRAFFIC SIGNAL CONTROLLERS SUPPLIED UNDER THIS CONTRACT SHALL BE ETHERNET EQUIPPED TRAFFICWARE NEMA ATC TS-2, TYPE 1 WITH THE CAPABILITY OF SUPPORTING NTCIP PROTOCOLS. TRAFFIC SIGNAL CONTROLLERS SHALL SUPPORT DIRECT ETHERNET COMMUNICATIONS FROM A PROPOSED ETHERNET SWITCH TO THE CONTROLLERS ETHERNET PORT. THE COMMUNICATIONS SYSTEM SHALL BE CAPABLE OF INTEGRATING WITH THE ETHERNET COMMUNICATIONS SYSTEM BACK TO THE EXISTING ADVANCED TRAFFIC SIGNAL MANAGEMENT SYSTEM (ATMS) SERVER.

THE SYSTEM SHALL EMPLOY AN IP-BASED COMMUNICATIONS NETWORK TO AND FROM THE EXISTING CENTRAL SYSTEM CONTROL COMPUTER. THE EQUIPMENT SUPPLIED AND INSTALLED SHALL BE CAPABLE OF UPLOAD TO AND DOWNLOAD FROM EACH OF THE SYSTEM'S TRAFFIC SIGNAL CONTROLLER DATABASES, REMOTELY ACCESS LOCAL INTERSECTION REPORTS, REMOTELY ACCESS PROCESSED VEHICLE DETECTOR DATA, AND PROVIDE REAL TIME INTERSECTION STATUS TO SUPPORT GRAPHICAL LOCAL AND SYSTEM MAPS.

THE CONTRACTOR SHALL BE SOLELY RESPONSIBLE FOR PROVIDING THE PROJECT WITH WORKING AND FULLY CONFIGURED CONTROLLERS FOR EACH INTERSECTION, DELIVERY AND COMPLETE SET-UP OF THE CENTRAL SYSTEM, INSTALLATION OF THE CENTRAL AND LOCAL INTERSECTION COMMUNICATIONS INTERFACE, AND COORDINATION WITH THE INFORMATION TECHNOLOGY (IT) PERSONNEL. THE CONTRACTOR IS FURTHER RESPONSIBLE FOR ANY LOCAL WIRING AT SYSTEM COMPUTER LOCATION, SYSTEM START-UP AND SYSTEM LOADING, ACCEPTANCE TESTING, TRAINING AND SYSTEM MAINTENANCE. IN ADDITION, THE CONTRACTOR SHALL FURNISH AND INSTALL AND/OR EXPAND THE EXISTING LIGHT-BASED EMERGENCY VEHICLE PREEMPTION SYSTEM COMPATIBLE WITH THE PREEMPTION EMITTERS OWNED BY THE CITY FIRE DEPARTMENT.

THE CONTRACTOR SHALL BE SOLELY RESPONSIBLE FOR FURNISHING AND INSTALLING ALL OTHER EQUIPMENT TO INCLUDE VEHICLE TRAFFIC SIGNALS, PEDESTRIAN SIGNALS, APS PEDESTRIAN BUTTONS AND SIGNS, EMERGENCY VEHICLE PREEMPTION PHASE SELECTORS (PACTS) REGIONAL TRANSPORTATION MANAGEMENT SYSTEMS (RTMS) SPECIFICATIONS, VIDEO DETECTION CAMERAS, VIDEO-BASED PRESENCE DETECTION SENSORS WITH BICYCLE ALGORITHM, FIELD WIRING, AND ALL OTHER EQUIPMENT NECESSARY TO PROVIDE COMPLETE AND OPERATIONAL TRAFFIC SIGNAL SYSTEMS. THE CONTRACTOR SHALL BE AWARE OF AND CONFORM TO ALL DETAILS FOR THE MATERIAL SPECIFICATIONS IN SPECIAL PROVISION 718.
13. ALL TRAFFIC SIGNAL CONTROLLER TIMING PARAMETERS SHALL BE PROGRAMMED TO PROVIDE OPTIMIZED FREE AND COORDINATED OPERATIONS. GIVEN THE COMPLEXITY TO MAINTAIN TRAFFIC FLOW AROUND THE CUMBERLAND MILLS AREA, PEER-TO-PEER OPERATIONS MAY BE DESIGNED AND IMPLEMENTED DURING SIGNAL SYSTEM START-UP IF IT IS DETERMINED NECESSARY TO IMPROVE TRAFFIC FLOW BEYOND THE PROPOSED COORDINATION SETTINGS. IF APPLICABLE, PEER-TO-PEER SETTINGS WILL BE FORMULATED AND INSTALLED BY THE SIGNAL CONTROLLER SUPPLIER/INTEGRATOR WITH INPUT FROM THE ENGINEER.
14. VIDEO DETECTION INSTALLATION-THE ENGINEER RESERVES THE RIGHT TO DIRECT THE CONTRACTOR TO FIELD ADJUST THE VIDEO DETECTOR MOUNTING HEIGHT FOR LOCAL CONDITIONS IDENTIFIED DURING OR AFTER INSTALLATION. NO ADDITIONAL COST WILL BE ALLOWED FOR FIELD ADJUSTING THE PIPE EXTENSIONS OR REWIRING AS NECESSARY. THIS WORK WILL BE INCIDENTAL TO THE 643.83 VIDEO DETECTION SYSTEM ITEMS.
15. THE CONTRACTOR SHALL BE RESPONSIBLE FOR SUBMITTING RED-LINE AS-BUILT DRAWINGS OF THE FINAL WORK TO THE ENGINEER. THOSE DRAWINGS SHALL BE ON A CLEAN SET OF PLANS SHOWING ALL CHANGES OR MODIFICATIONS TO THE BID PLANS.
16. THE CONTRACTOR SHALL PERFORM THE WORK IN A MANNER THAT WILL REQUIRE THE LEAST AMOUNT OF DOWNTIME TO THE EXISTING TRAFFIC SIGNAL OPERATIONS AT MAIN STREET AND FOREST STREET. ANY POLICE DETAIL REQUIRED (AS DEEMED NECESSARY BY THE RESIDENT ENGINEER) WILL BE PAID FOR BY THE CONTRACTOR.
17. THE CONTRACTOR IS DIRECTED TO PROJECT SPECIAL PROVISION 718 FOR ADDITIONAL INFORMATION RELATED TO THE FOLLOWING:
 -
 - 718.07 TRAFFIC CONTROLLER
 - 718.13 TRAFFIC SIGNAL CONTROL SYSTEM, INCLUDING DETAILS FOR START-UP AND SYSTEM LOADING, ACCEPTANCE TESTING, TRAINING, AND TECHNICAL SUPPORT
 - 718.14 EMERGENCY VEHICLE PREEMPTION SYSTEM
 - 718.15 SINGLE MODE FIBER OPTIC CABLE
 - 718.16 TWELVE (12) POSITION FIBER OPTIC PATCH PANEL
 - 718.17 ETHERNET SWITCH WITH FIBER OPTIC INTERFACES
 - 718.18 PEDESTRIAN CROSSING SYSTEM

SPECIAL PROVISION 718 EXPANDS UPON THE INFORMATION FOUND IN THESE SIGNAL NOTES. AS SUCH, THE MORE RESTRICTIVE LANGUAGE BETWEEN THESE NOTES AND SPECIAL PROVISION 718 SHALL GOVERN THE WORK TO BE PERFORMED UNDER THIS PROJECT.

DAILY AND WEEKLY COORDINATION SCHEDULE

	MON.-FRI.	SATURDAY	SUNDAY
NTCIP PLAN 254 FREE OPERATIONS MAX 1	0000 - 0630 1930 - 2400	0000 - 1000 1700 - 2400	0000 - 1000 1700 - 2400
PLAN 1 65 SECS (MIDDAY/SAT/SUN) MAX 2	1015 - 1530 1830 - 1930	1000 - 1700	1000 - 1700
PLAN 3 70 SECS (AM) MAX 2	0630 - 1015	-	-
PLAN 3 75 SECS (PM) MAX 2	1530 - 1830	-	-

WEEK	DAY OF WEEK						
PROG	SUN	MON	TUE	WED	THU	FRI	SAT
JAN-DEC	2	1	1	1	1	1	2

EVENT	TIME			ACTION
	HR	MIN	SEC	
DAY PLAN 1				
1	00	00	00	54
2	06	30	00	2
3	08	45	00	1
4	10	15	00	1
5	15	30	00	3
6	18	30	00	1
7	19	30	00	54
DAY PLAN 2				
1	00	00	00	54
2	10	00	00	1
3	17	00	00	54



STATE OF MAINE
DEPARTMENT OF TRANSPORTATION
PROJECT NO. STP-1863(700)
WIN
18637.00
HIGHWAY PLANS

PROJ. MANAGER	B. KEEZER	DATE
DESIGN-DETAILED	JAR	04/19
CHECKED-REVIEWED	CMB	04/19
DESIGN-DETAILED		
REVISIONS 1		
REVISIONS 2		
REVISIONS 3		
REVISIONS 4		
FIELD CHANGES		

SIGNALIZATION OF
CUMBERLAND MILLS ROTARY
TRAFFIC SIGNAL NOTES

SHEET NUMBER
37
OF 53

Date: 2/17/2020

Username: jrobert

Division: HIGHWAY

Filename: ... \HIGHWAY\MSTA\037_Signal_1.dgn

LIST OF MAJOR ITEMS

EQUIPMENT AND WORK ITEMS 643.80	QUANTITY	EQUIPMENT AND WORK ITEMS 643.80	QUANTITY
FURNISH AND INSTALL NEW P-TYPE BASE MOUNTED NEMA TS2, TYPE 1 METERED MAINEDOT SPEC CABINET PAINTED BLACK ENAMEL COMPLETE WITH GENERATOR TRANSFER SWITCH AND ALL ANCILLARY EQUIPMENT AND WIRING	1	FURNISH AND INSTALL PREEMPTION CONFIRMATION RED STROBE WITH CABLE	1
FURNISH AND INSTALL NEW NEMA ATC TRAFFIC SIGNAL CONTROLLER	1	FURNISH AND INSTALL 12-POSITION PATCH PANEL	1
FURNISH AND INSTALL NEW 16-CHANNEL ETHERNET EQUIPPED ENHANCED MALFUNCTION MANAGEMENT UNIT (MMU)	1	FURNISH AND INSTALL ENVIRONMENTALLY HARDENED FIBER OPTIC ETHERNET SWITCH WITH FIBER OPTIC INTERFACES	1
FURNISH AND INSTALL ONE-WAY, 3-SECTION, 12-INCH BLACK SIGNAL HEADS WITH LED MODULES WITH BLACK TUNNEL VISORS AND 5-INCH RETROREFLECTIVE LOUVERED BACKPLATES MOUNTED ON MAST ARMS WITH ASTROBRACKETS	4	FURNISH AND INSTALL MAST ARM AND BRACKET MOUNTED SIGNS	3
FURNISH AND INSTALL ONE-WAY, 3-SECTION, 12-INCH BLACK SIGNAL HEADS WITH LED MODULES WITH BLACK TUNNEL VISORS AND 5-INCH RETROREFLECTIVE LOUVERED BACKPLATES MOUNTED ON POSTS OR POLES	4	FURNISH AND INSTALL BLANK-OUT SIGN	1
FURNISH AND INSTALL ONE-WAY, 16 X 18 INCH LED BRACKET MOUNTED BLACK COUNTDOWN PEDESTRIAN SIGNAL HEADS	3	FURNISH AND INSTALL ELECTRICAL SERVICE	1
FURNISH AND INSTALL ONE-WAY, 16 X 18 INCH LED TOP OF POST MOUNTED BLACK COUNTDOWN PEDESTRIAN SIGNAL HEADS	3	FURNISH AND INSTALL NEW SIGNAL CABLE	-
FURNISH AND INSTALL ADA COMPLIANT ACCESSIBLE PEDESTRIAN SIGNAL (APS) PUSH BUTTON WITH RIO-3E INFORMATIONAL SIGN	6	FURNISH AND INSTALL PATCH CABLES AND IMPLEMENT REMOTE VIDEO, CONTROLLER, PREEMPTION, AND MMU COMMUNICATIONS TO EXISTING ADVANCED TRAFFIC MANAGEMENT SYSTEM	-
FURNISH AND INSTALL 4-CHANNEL PREEMPTION PHASE SELECTOR WITH SYSTEM CHASSIS	1	IMPLEMENT SYSTEM BASED AND LOCAL SIGNAL TIMINGS	-
FURNISH AND INSTALL LIGHT-BASED PREEMPTION RECEIVERS WITH DETECTOR CABLE	2		

THE LISTED QUANTITIES ARE APPROXIMATE AND ARE FURNISHED FOR INFORMATION ONLY.

PROPOSED 15' TRAFFIC SIGNAL POST WITH PEDESTRIAN SIGNAL HEAD, APS PUSHBUTTON, RIO-3EL INFORMATIONAL SIGN, AND VEHICULAR SIGNAL HEAD ON OFFSET BRACKET SO WOOD POLE DOES NOT OCCLUDE SIGNAL INDICATIONS

PROPOSED 10' PEDESTAL POST WITH VEHICULAR SIGNAL HEADS, PEDESTRIAN SIGNAL HEAD, APS PUSHBUTTON, AND RIO-3ER INFORMATIONAL SIGN AND TOP MOUNTED PREEMPTION RECEIVERS

PROPOSED 8' PEDESTAL POST WITH PEDESTRIAN SIGNAL HEAD, APS PUSHBUTTON, AND RIO-3EL AND RIO-3ER INFORMATIONAL SIGN

PROPOSED TWIN MAST ARM POLE WITH 35' ARM AND 25' ARM ON NEW FOUNDATION

PROPOSED NEMA TS2-1 ETHERNET EQUIPPED ATC TRAFFIC SIGNAL CONTROLLER IN NEW METERED P-TYPE CABINET COMPLETE WITH ANCILLARY EQUIPMENT INCLUDING MMU, ETHERNET SWITCH AND PATCH PANEL MOUNTED ON A CONCRETE FOUNDATION. PROGRAM CONTROLLER WITH LOCAL AND SYSTEM TIMINGS. PROVIDE NEW WIRED FIBER OPTIC INTERCONNECT CABLE IMPLEMENT REMOTE VIDEO, CONTROLLER, PREEMPTION AND MMU COMMUNICATION TO EXISTING ATMS.

POWER FROM EXISTING UTILITY POLE WITH PROPOSED RISER

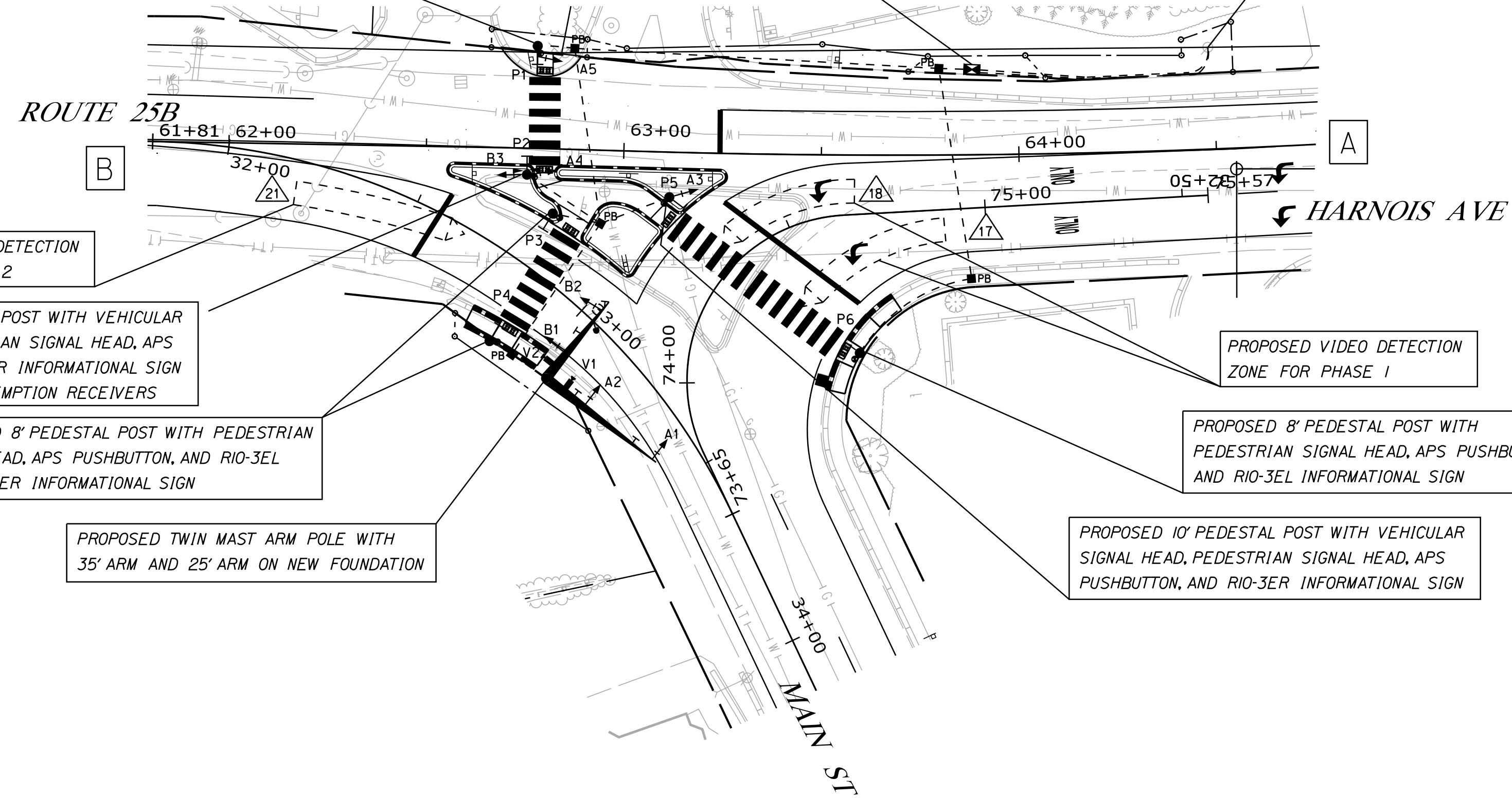

PROPOSED INDICATIONS

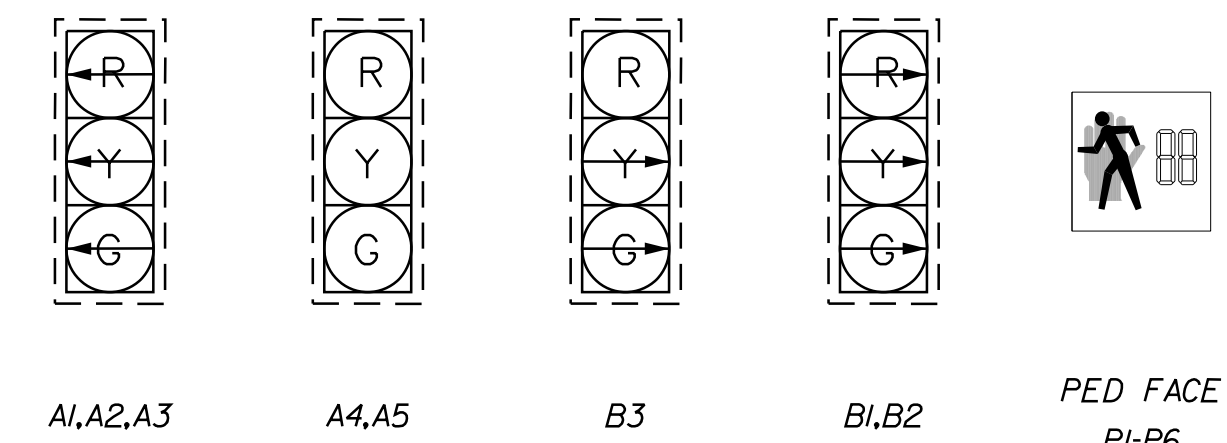

NOTE: ALL INDICATIONS SHALL BE 12' LIGHT EMITTING DIODES (LED'S) WITH 5' LOUVERED RETROREFLECTIVE BACKPLATES

PHASE DIAGRAM

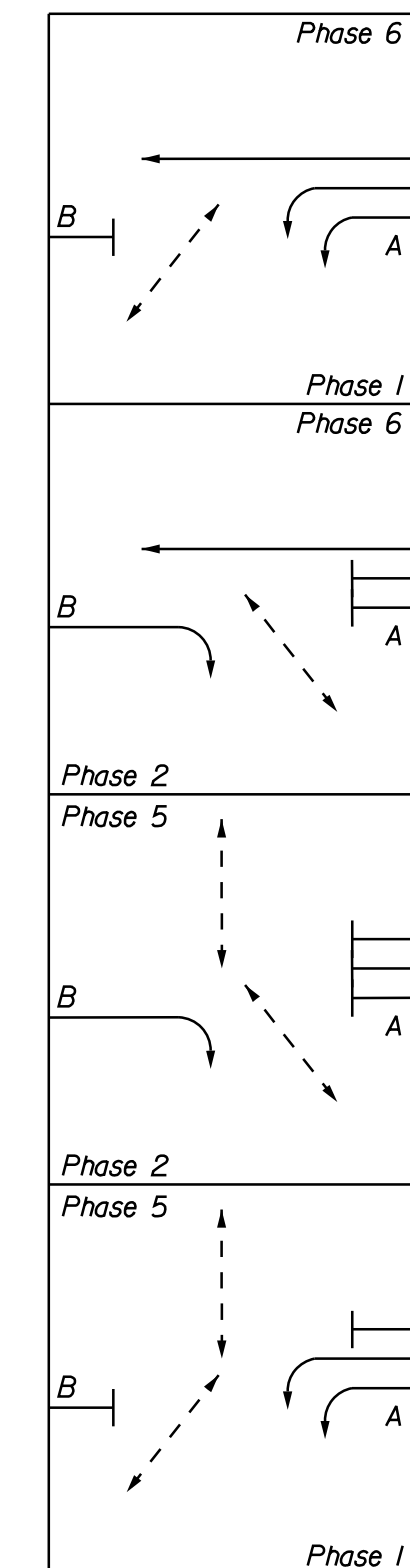

WHERE:
 → PROTECTED TRAFFIC MOVEMENT
 ⇄ PEDESTRIAN MOVEMENT

SIGNAL TIMING

	PHASE 1	PHASE 2	PHASE 5	PHASE 6
MINIMUM INITIAL	7	5	5	7
PASSAGE TIME	3.0	3.0	1.0	3.0
MAXIMUM 1	33	27	13	50
MAXIMUM 2	25	25	13	40
YELLOW	3.0	3.0	3.0	3.0
ALL RED	2.0	2.0	0.0	2.0
PED WALK	5	5	5	-
PED CLEAR	7	13	7	-
RECALL	SOFT	OFF	OFF	SOFT
DETECTOR	PR	PR	PED	PR
PREEMPT PRIORITY	4.6	3	-	3,4,6
FLASH	Y	R	OFF	Y
DUAL ENTRY	OFF	ON	OFF	ON

NOTE:
 1. IN THE EVENT OF A CONFLICT OR MALFUNCTION PHASES 1 AND 6 SHALL FLASH YELLOW AND ALL OTHER PHASES SHALL FLASH RED. PEDESTRIAN SIGNAL HEADS SHALL BE BLANK DURING FLASHING OPERATIONS.
 2. PR = STOPLINE PRESENCE DETECTION

DETECTOR SCHEDULE

CAMERA	DETECTOR				DETECTOR CARD IN VEHICLE DETECTION RACK				
	PLAN ID	STREET	DIRECTION	LANE	φ	TYPE	SLOT NO	DETECTOR NO	CHANNEL
CAMERA V1	17	HARNOIS AVE	SOUTHBOUND	LEFT	1	FULL VIDEO THERMAL	1	17	1
	18	HARNOIS AVE	SOUTHBOUND	LEFT	1		18		
CAMERA V2	21	MAIN ST	EASTBOUND	RIGHT	2	FULL VIDEO THERMAL	1	21	2
	22-24	SPARE							

DETECTOR NOTES:
 DETECTORS 1-16 SHALL BE CONNECTED TO DETECTOR PANEL TEST INPUT BUTTONS
 CONTRACTOR SHALL COMPLETE THE DETECTOR SCHEDULE FOR RECORD OF DETECTION PROGRAMMING INTO THE TRAFFIC SIGNAL CONTROLLER

COORDINATION CYCLE/SPLIT/OFFSET SCHEDULE
 ALL ENTRIES IN SECONDS

	PLAN 1	PLAN 2	PLAN 3	PLAN 4
CYCLE LENGTH	65	70	75	80
OFFSET (End Grn)	49	2	58	59
COORDINATED φ	φ 1	φ 1	φ 1	φ 1
SPLIT TIME φ 1	30	35	35	36
SPLIT TIME φ 2	35	35	40	44
SPLIT TIME φ 3	0	0	0	0
SPLIT TIME φ 4	0	0	0	0
SPLIT TIME φ 5	16	16	16	16
SPLIT TIME φ 6	49	54	59	64
SPLIT TIME φ 7	0	0	0	0
SPLIT TIME φ 8	0	0	0	0

COORDINATION NOTES:
 1. OFFSET IS REFERENCED TO THE END OF THE COORDINATED PHASE GREEN (SEE TABLE ABOVE).
 2. COORDINATION TO OPERATE BY TIME-OF-DAY (SEE DAILY AND WEEKLY COORDINATION SCHEDULE)

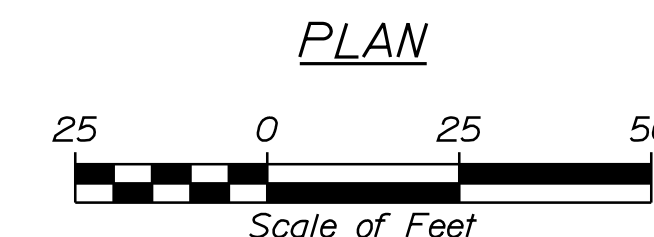

STATE OF MAINE
 DEPARTMENT OF TRANSPORTATION
 PROJECT NO. STP-1863(700)
 WIN 18637.00
 HIGHWAY PLANS

SIGNALIZATION OF
 CUMBERLAND MILLS ROTARY
 TRAFFIC SIGNAL PLAN
 (1 OF 10)

SHEET NUMBER
 38
 OF 53

PROJ. MANAGER	DATE	BY	REVISIONS
DESIGN-DETAILED	04/19	JAR	1
CHECKED-REVIEWED	04/19	CMB	2
DESIGN-DETAILED			3
DESIGN-DETAILED			4
REVISIONS 1			5
REVISIONS 2			6
REVISIONS 3			7
REVISIONS 4			8
FIELD CHANGES			9

LIST OF MAJOR ITEMS

EQUIPMENT AND WORK ITEMS	QUANTITY
FURNISH AND INSTALL PRECAST JUNCTION BOX (ITEM 626.11)	5
FURNISH AND INSTALL METALLIC CONDUIT (ITEM 626.21)	65 LF
FURNISH AND INSTALL (3-INCH) NON-METALLIC CONDUIT (ITEM 626.22)	530 LF
FURNISH AND INSTALL 24-INCH FOUNDATION (ITEM 626.31)	7
FURNISH AND INSTALL 48-INCH DIAMETER, 54-INCH DIAMETER, 60-INCH DIAMETER FOUNDATIONS (ITEM 626.333)	6.5 CY
FURNISH AND INSTALL CONTROLLER CABINET FOUNDATION (ITEM 626.35)	1
FURNISH AND INSTALL VIDEO DETECTION SYSTEM (ITEM 643.83)	1
FURNISH AND INSTALL POLE RISER (ITEM 643.90)	1
FURNISH AND INSTALL APPROXIMATELY 1720 LINEAR FEET OF 12-STRAND FIBER OPTIC INTERCONNECT CABLE FROM CONTROLLER CABINET AT MAIN STREET/ WESTBROOK ARTERIAL TO CONTROLLER CABINET (ITEM 643.90)	1
FURNISH AND INSTALL GALVANIZED STEEL TWIN MAST ARM POLE PAINTED BLACK ENAMEL WITH 35-FOOT AND 25-FOOT SIGNAL ARMS (ITEM 643.91)	1
FURNISH AND INSTALL (8-FOOT) PEDESTAL POLE PAINTED BLACK ENAMEL (ITEM 643.92)	3
FURNISH AND INSTALL (10-FOOT) PEDESTAL POLE PAINTED BLACK ENAMEL (ITEM 643.92)	2
FURNISH AND INSTALL (15-FOOT) PEDESTAL POLE PAINTED BLACK ENAMEL (ITEM 643.92)	1

THE LISTED QUANTITIES ARE APPROXIMATE AND ARE FURNISHED FOR INFORMATION ONLY.

PROPOSED AERIAL MOUNTED FIBER OPTIC CABLE

ROUTE 25B

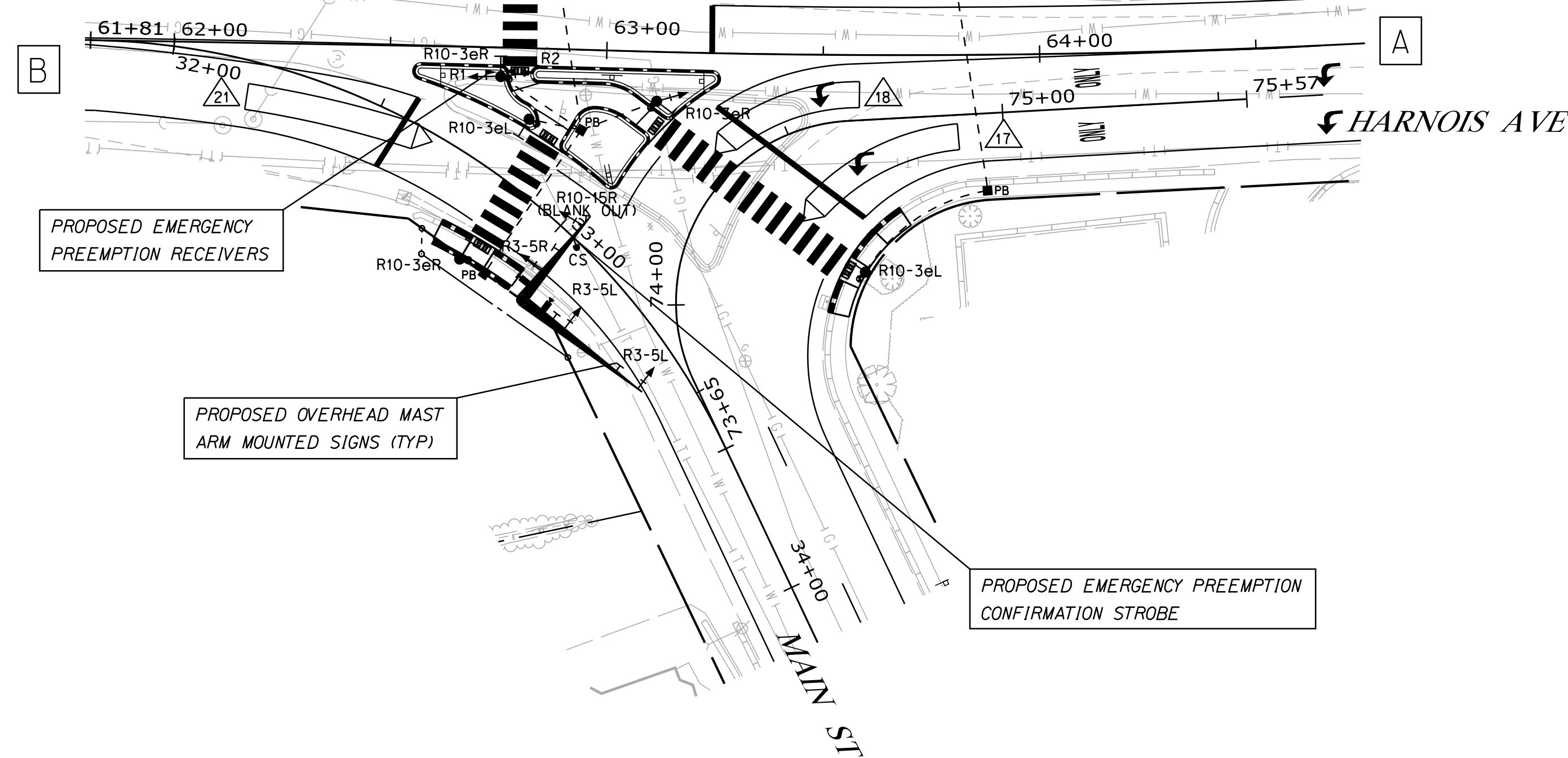

INSTALL RISER FOR FIBER OPTIC CABLE ON EXISTING POLE

PROPOSED AERIAL MOUNTED FIBER OPTIC CABLE

PROPOSED EMERGENCY PREEMPTION RECEIVERS

PROPOSED OVERHEAD MAST ARM MOUNTED SIGNS (TYP)

PROPOSED EMERGENCY PREEMPTION CONFIRMATION STROBE

PROPOSED SIGNS

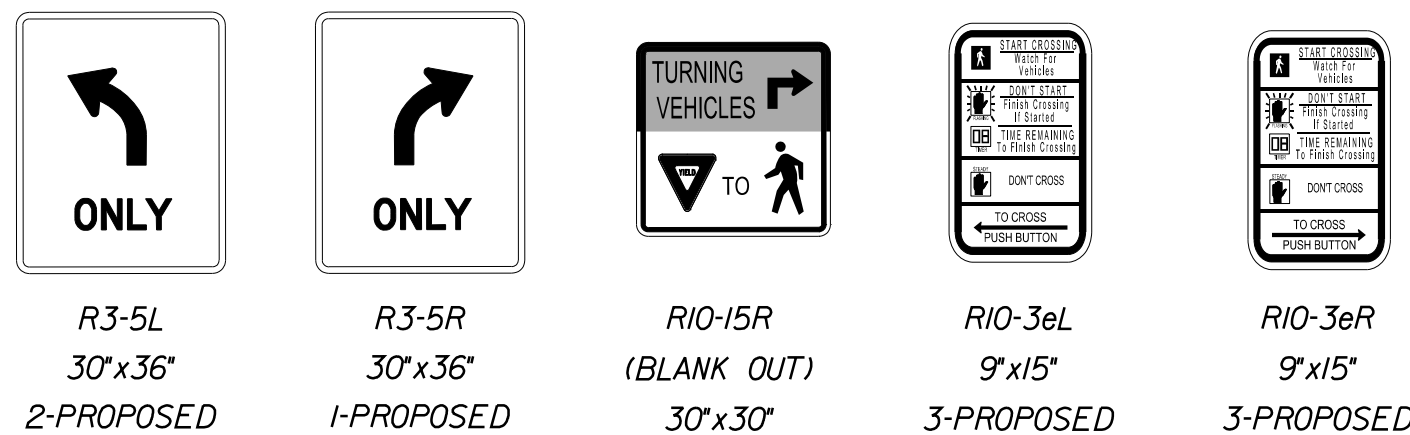

1-PROPOSED

NOTE:
BLANK OUT SIGN SHALL BE LINKED TO PHASE 5 AND BE ON ONLY WHEN THE MAIN STREET PEDESTRIAN CROSSING IS ACTIVE

PLAN

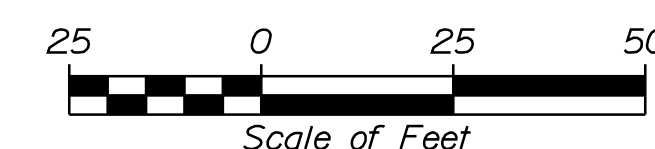

EMERGENCY VEHICLE PREEMPTION OPERATION

ID	PREEMPT ASSIGNMENT	RECEIVER PRIORITY	ACTIVE PHASE
R1	1	3	φ 2 & φ 6
R2	2	4	φ 1 & φ 6
		5	NOT USED
R2 (WARREN)		6	φ 1 & φ 6

EMERGENCY VEHICLE PRE-EMPTION NOTES:

- EMERGENCY VEHICLE PRE-EMPTION SIGNALS SHALL BE TRANSMITTED BY OPTICAL EMITTERS (PROVIDED BY OTHERS) MOUNTED IN EMERGENCY VEHICLES AND RECEIVED BY OPTICAL DETECTORS LOCATED AT THE INTERSECTION.
- PRE-EMPTION SIGNALS SHALL BE SERVICED ON A PRIORITY BASIS WITH RECEIVERS ASSIGNED DESCENDING PRIORITIES (3 = HIGHEST, 6 = LOWEST), NOTING 5 IS NOT USED.
- IN RESPONSE TO A PRE-EMPTION SIGNAL RECEIVED AT AN INTERSECTION BY AN OPTICAL DETECTOR, THE CONTROLLER SHALL HOLD OR ADVANCE TO AND HOLD THE EMERGENCY ACTIVE PHASE GREEN FOR A MINIMUM OF 10 SECONDS OR UNTIL THE PRE-EMPTION SIGNAL CEASES. THE CONTROLLER SHALL THEN TIME PRE-EMPTION PHASE CLEARANCE (3.0 SECONDS YELLOW AND 2.0 SECONDS ALL RED) AND SERVICE SUBSEQUENT EMERGENCY ACTIVE PHASES AS NECESSARY. AT THE COMPLETION OF THE PRE-EMPTION CYCLE, THE CONTROLLER SHALL TIME THE PRE-EMPTION CLEARANCE AND RESUME NORMAL SIGNAL OPERATION.
- MINIMUM GREEN AND NORMAL VEHICLE CLEARANCE SHALL BE PROVIDED ON PHASES THAT ARE TO BE TERMINATED BY PRE-EMPTION DEMAND.
- CONFIRMATION STROBES SHALL BE ILLUMINATED WHENEVER ANY EMERGENCY VEHICLE PREEMPTION GREEN IS ON.
- PREEMPTION SETTINGS SHALL BE PROGRAMMED SO THAT DURING PREEMPT, IF THE TRAFFIC CONTROLLER IS OPERATING UNDER COORDINATION THAT THE COORDINATION CONTINUES TO TIME IN THE BACKGROUND AND COORDINATED OPERATIONS RESUME FOLLOWING PREEMPTION WITHOUT CONTROLLER RESYNCHRONIZATION.
- φ 1 & φ 6 PREEMPTION SHALL BE PROGRAMMED AND TRIGGERED BY A WARREN AVENUE PREEMPTION.

LEGEND	
	PROPOSED MAST ARM
	PROPOSED VEHICULAR HEAD WITH BACKPLATE
	PROPOSED PEDESTAL POLE
	PROPOSED PEDESTRIAN SIGNAL HEAD WITH APS PUSHBUTTON AND INFORMATIONAL SIGN
	PROPOSED CABINET WITH CONTROLLER
	PROPOSED ELECTRICAL JUNCTION BOX
	PROPOSED SIGNAL CONDUIT
	PROPOSED COMMUNICATIONS
	PROPOSED PREEMPTION RECEIVER
	PROPOSED CONFIRMATION STROBE
	PROPOSED VIDEO DETECTION ZONE
	PROPOSED VIDEO DETECTION CAMERA
	PROPOSED METER PEDESTAL

STATE OF MAINE
DEPARTMENT OF TRANSPORTATION
PROJECT NO. STP-1863(700)

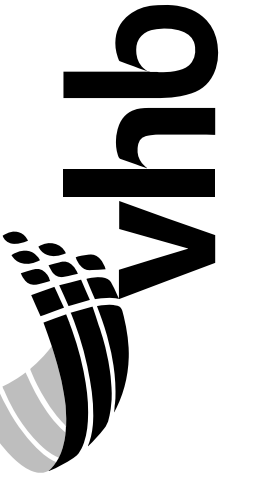

PROJ. MANAGER	B. KEEZER	DATE
DESIGN DETAILED	MLC	04/19
CHECKED/REVIEWED	JAR	04/19
DESIGNED/REVIEWED	CMB	
DESIGNS DETAILED		
REVISIONS 1		
REVISIONS 2		
REVISIONS 3		
REVISIONS 4		
FIELD CHANGES		

SIGNALIZATION OF
CUMBERLAND MILLS ROTARY
TRAFFIC SIGNAL PLAN
(2 OF 10)

SHEET NUMBER
39
OF 53

LIST OF MAJOR ITEMS

EQUIPMENT AND WORK ITEMS 643.80	QUANTITY	EQUIPMENT AND WORK ITEMS 643.80	QUANTITY
FURNISH AND INSTALL NEW P-TYPE BASE MOUNTED NEMA TS2, TYPE 1 METERED MAINDOT SPEC CABINET PAINTED BLACK ENAMEL COMPLETE WITH GENERATOR TRANSFER SWITCH AND ALL ANCILLARY EQUIPMENT AND WIRING	1	FURNISH AND INSTALL PREEMPTION CONFIRMATION RED STROBE WITH CABLE	1
FURNISH AND INSTALL NEW NEMA ATC TRAFFIC SIGNAL CONTROLLER	1	FURNISH AND INSTALL 12-POSITION PATCH PANEL	1
FURNISH AND INSTALL NEW 16-CHANNEL ETHERNET EQUIPPED ENHANCED MALFUNCTION MANAGEMENT UNIT (MMU)	1	FURNISH AND INSTALL ENVIRONMENTALLY HARDENED FIBER OPTIC ETHERNET SWITCH WITH FIBER OPTIC INTERFACES	1
FURNISH AND INSTALL ONE-WAY, 3-SECTION, 12-INCH BLACK SIGNAL HEADS WITH LED MODULES WITH BLACK TUNNEL VISORS AND 5-INCH RETROREFLECTIVE LOUVERED BACKPLATES MOUNTED ON MAST ARMS WITH ASTROBRACKETS	6	FURNISH AND INSTALL MAST ARM AND BRACKET MOUNTED SIGNS	6
FURNISH AND INSTALL ONE-WAY, 3-SECTION, 12-INCH BLACK SIGNAL HEADS WITH LED MODULES WITH BLACK TUNNEL VISORS AND 5-INCH RETROREFLECTIVE LOUVERED BACKPLATES MOUNTED ON POST OR POLES	2	FURNISH AND INSTALL ELECTRICAL SERVICE	1
FURNISH AND INSTALL ONE-WAY, 16 X 18 INCH LED BRACKET MOUNTED BLACK COUNTDOWN PEDESTRIAN SIGNAL HEADS	2	FURNISH AND INSTALL NEW SIGNAL CABLE	-
FURNISH AND INSTALL ONE-WAY, 16 X 18 INCH LED TOP OF POST MOUNTED BLACK COUNTDOWN PEDESTRIAN SIGNAL HEADS	4	FURNISH AND INSTALL PATCH CABLES AND IMPLEMENT REMOTE VIDEO, CONTROLLER, PREEMPTION, AND MMU COMMUNICATIONS TO EXISTING ADVANCED TRAFFIC MANAGEMENT SYSTEM	-
FURNISH AND INSTALL ADA COMPLIANT ACCESSIBLE PEDESTRIAN SIGNAL (APS) PUSH BUTTON WITH RIO-3E INFORMATIONAL SIGN	6	IMPLEMENT SYSTEM BASED AND LOCAL SIGNAL TIMINGS	-
FURNISH AND INSTALL 4-CHANNEL PREEMPTION PHASE SELECTOR WITH SYSTEM CHASSIS	1		
FURNISH AND INSTALL LIGHT-BASED PREEMPTION RECEIVERS WITH DETECTOR CABLE	2		

THE LISTED QUANTITIES ARE APPROXIMATE AND ARE FURNISHED FOR INFORMATION ONLY.

PROPOSED NEMA TS2-1 ETHERNET EQUIPPED ATC TRAFFIC SIGNAL CONTROLLER IN NEW METERED P-TYPE CABINET COMPLETE WITH ANCILLARY EQUIPMENT INCLUDING MMU, ETHERNET SWITCH AND PATCH PANEL MOUNTED ON A CONCRETE FOUNDATION. PROGRAM CONTROLLER WITH LOCAL AND SYSTEM TIMINGS. PROVIDE NEW WIRED FIBER OPTIC INTERCONNECT CABLE IMPLEMENT REMOTE VIDEO, CONTROLLER, PREEMPTION AND MMU COMMUNICATION TO EXISTING ATMS.

POWER FROM EXISTING UTILITY POLE WITH PROPOSED RISER

PROPOSED 20' MAST ARM POLE ON NEW FOUNDATION

PROPOSED 10' PEDESTAL POST WITH VEHICULAR SIGNAL HEAD, PEDESTRIAN SIGNAL HEAD, APS PUSHBUTTON, AND RIO-3EL INFORMATIONAL SIGN

OVERHEAD SIGN MAST ARM. SEE SIGNING AND PAVEMENT MARKING PLANS FOR DETAILS

PROPOSED VIDEO DETECTION ZONES FOR PHASE 2

PROPOSED 8' PEDESTAL POST WITH PEDESTRIAN SIGNAL HEAD, APS PUSHBUTTON, AND RIO-3EL INFORMATIONAL SIGN

PROPOSED 8' PEDESTAL POST WITH PEDESTRIAN SIGNAL HEAD, APS PUSHBUTTON, AND RIO-3ER INFORMATIONAL SIGN

PROPOSED VIDEO DETECTION ZONES FOR PHASE 1

PROPOSED 8' PEDESTAL POST WITH PEDESTRIAN SIGNAL HEAD, APS PUSHBUTTON, AND RIO-3EL INFORMATIONAL SIGN

PROPOSED TWIN MAST ARM POLE WITH 25' ARM AND 45' ARM ON NEW FOUNDATION

PROPOSED INDICATIONS

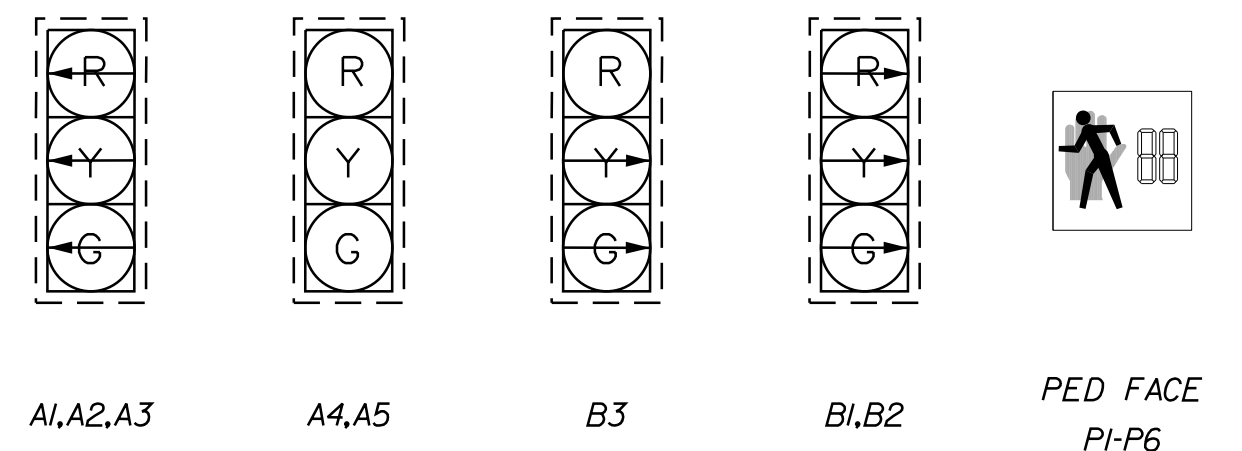

NOTE: ALL INDICATIONS SHALL BE 12" LIGHT EMITTING DIODES (LED'S) WITH 5" LOUVERED RETROREFLECTIVE BACKPLATES

PHASE DIAGRAM

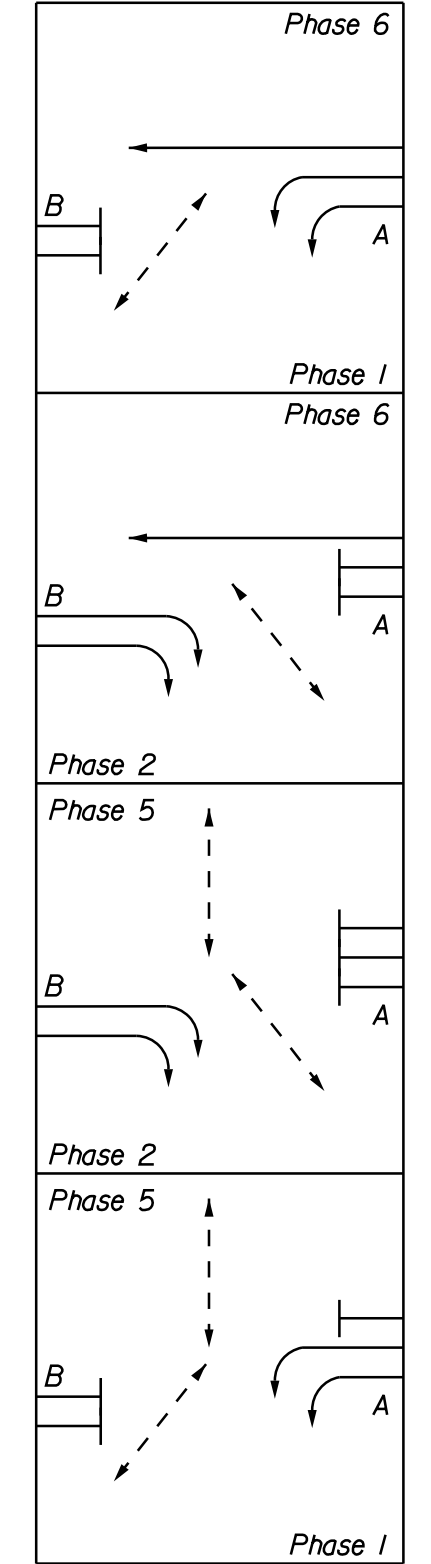

WHERE:
 -> PROTECTED TRAFFIC MOVEMENT
 - - -> PEDESTRIAN MOVEMENT

LEGEND

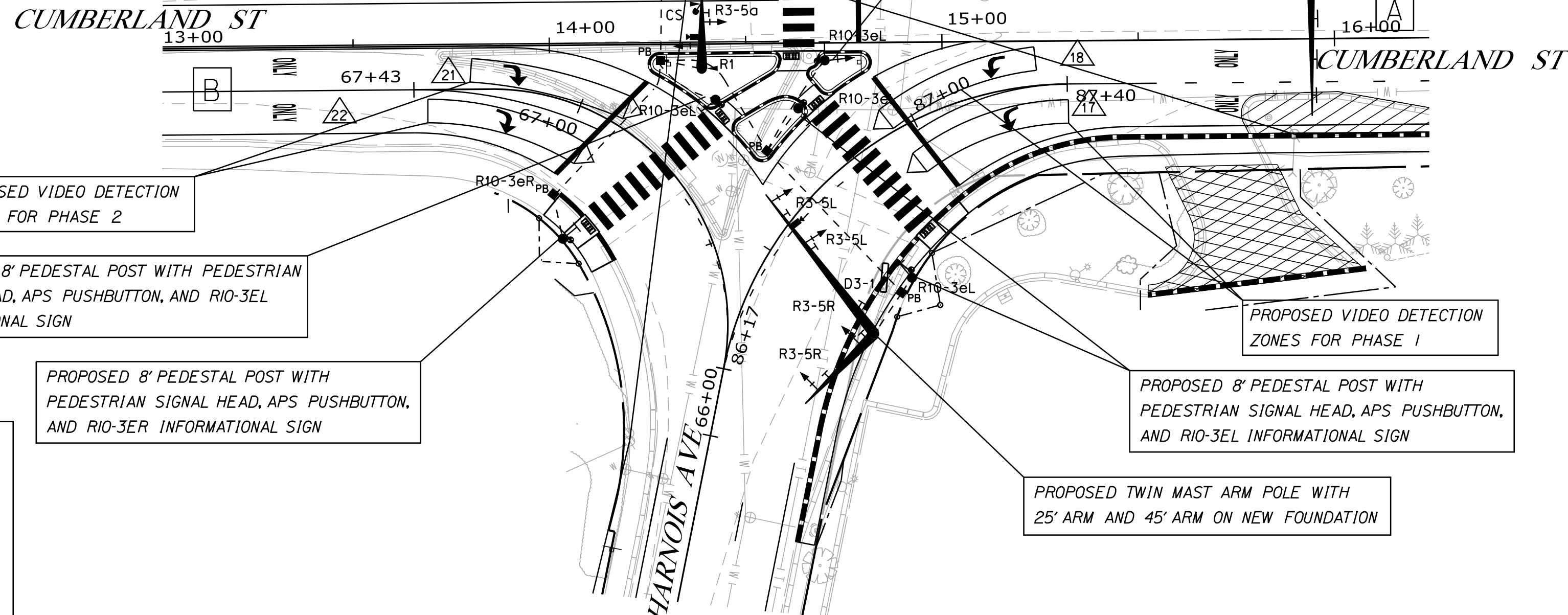
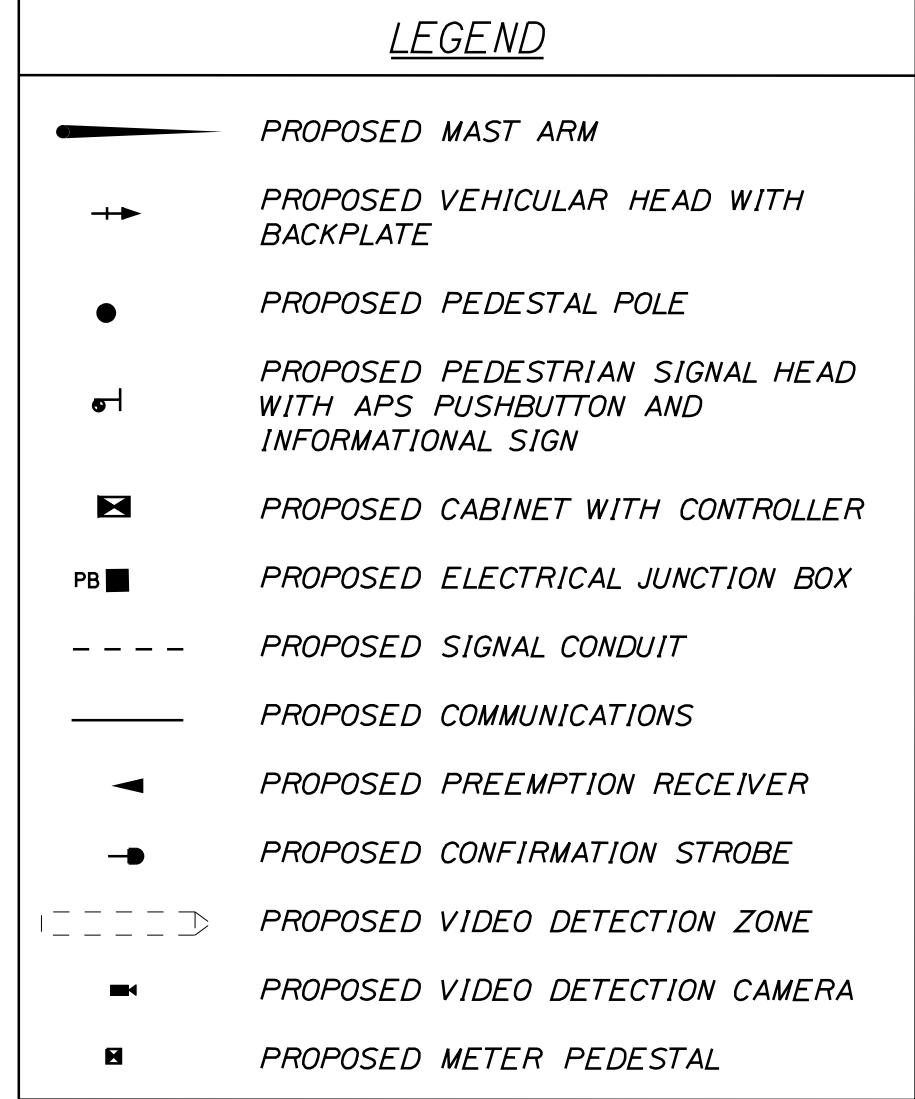

SIGNAL TIMING

	PHASE 1	PHASE 2	PHASE 5	PHASE 6
MINIMUM INITIAL	7	5	5	7
PASSAGE TIME	3.0	3.0	1.0	3.0
MAXIMUM 1	25	25	13	40
MAXIMUM 2	35	25	13	50
YELLOW	3.0	3.0	3.0	3.0
ALL RED	2.0	2.0	0.0	2.0
PED WALK	5	5	5	-
PED CLEAR	10	10	7	-
RECALL	SOFT	OFF	OFF	SOFT
DETECTOR	PR	PR	PED	PR
PREEMPT PRIORITY	3,6	4	-	3,4,6
FLASH	Y	R	OFF	Y
DUAL ENTRY	OFF	ON	OFF	ON

NOTE:
 1. IN THE EVENT OF A CONFLICT OR MALFUNCTION PHASES 1 AND 6 SHALL FLASH YELLOW AND ALL OTHER PHASES SHALL FLASH RED. PEDESTRIAN SIGNAL HEADS SHALL BE BLANK DURING FLASHING OPERATIONS.
 2. PR = STOPLINE PRESENCE DETECTION.

DETECTOR SCHEDULE

CAMERA	DETECTOR				DETECTOR CARD IN VEHICLE DETECTION RACK					
	PLAN ID	STREET	DIRECTION	LANE	φ	TYPE	SLOT NO	DETECTOR NO	CHANNEL	
VI	17	CUMBERLAND ST	WESTBOUND	LEFT	1	FULL VIDEO THERMAL	1	17	1	
	18	CUMBERLAND ST	WESTBOUND	LEFT	1				18	
	(19-20)	SPARE								
V2	21	CUMBERLAND ST	EASTBOUND	RIGHT	2	FULL VIDEO THERMAL	1	21	2	
	22	CUMBERLAND ST	EASTBOUND	RIGHT	2				22	
	(23-24)	SPARE								

DETECTOR NOTES:
 DETECTORS 1-16 SHALL BE CONNECTED TO DETECTOR PANEL TEST INPUT BUTTONS
 CONTRACTOR SHALL COMPLETE THE DETECTOR SCHEDULE FOR RECORD OF DETECTION PROGRAMMING INTO THE TRAFFIC SIGNAL CONTROLLER

COORDINATION CYCLE/SPLIT/OFFSET SCHEDULE
 ALL ENTRIES IN SECONDS

	PLAN 1	PLAN 2	PLAN 3	PLAN 4	COORDINATION MODE SET TO FIXED FORCE-OFF
CYCLE LENGTH	65	70	75	80	
OFFSET (End Grn)	49	2	58	59	
COORDINATED φ	φ1	φ1	φ1	φ1	
SPLIT TIME φ1	30	35	35	36	
SPLIT TIME φ2	35	35	40	44	
SPLIT TIME φ3	0	0	0	0	
SPLIT TIME φ4	0	0	0	0	
SPLIT TIME φ5	16	16	16	16	
SPLIT TIME φ6	49	54	59	64	
SPLIT TIME φ7	0	0	0	0	
SPLIT TIME φ8	0	0	0	0	

COORDINATION NOTES:
 1. OFFSET IS REFERENCED TO THE END OF THE COORDINATED PHASE GREEN (SEE TABLE ABOVE).
 2. COORDINATION TO OPERATE BY TIME-OF-DAY (SEE DAILY AND WEEKLY COORDINATION SCHEDULE)

PLAN

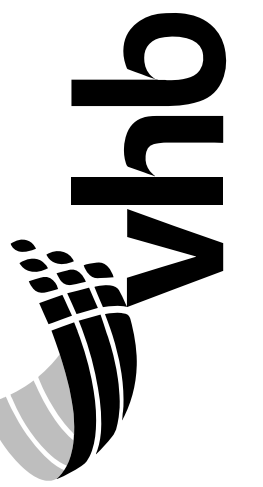
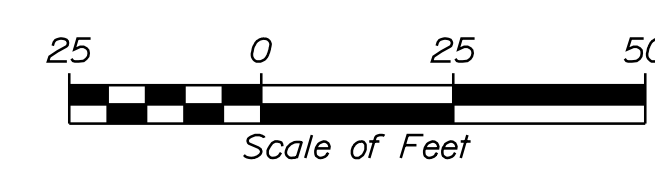

PROJ. MANAGER	DATE	BY	DATE
DESIGN-DETAILED	04/19	JAR	04/19
CHECKED-REVIEWED		CMB	
DESIGN-DETAILED			
DESIGN-DETAILED			
REVISIONS 1			
REVISIONS 2			
REVISIONS 3			
REVISIONS 4			
FIELD CHANGES			

SIGNALIZATION OF
 CUMBERLAND MILLS ROTARY
 TRAFFIC SIGNAL PLAN
 (3 OF 10)

LIST OF MAJOR ITEMS

EQUIPMENT AND WORK ITEMS	QUANTITY
FURNISH AND INSTALL PRECAST JUNCTION BOX (ITEM 626.11)	5
FURNISH AND INSTALL METALLIC CONDUIT (ITEM 626.21)	20 LF
FURNISH AND INSTALL (3-INCH) NON-METALLIC CONDUIT (ITEM 626.22)	355 LF
FURNISH AND INSTALL 24-INCH FOUNDATION (ITEM 626.32)	6
FURNISH AND INSTALL 30-INCH DIAMETER, GREATER THAN 8-FEET LONG AND ALL 36-INCH AND 42-INCH DIAMETER FOUNDATIONS (ITEM 626.332)	3.5 CY
FURNISH AND INSTALL 48-INCH DIAMETER, 54-INCH DIAMETER, 60-INCH DIAMETER FOUNDATIONS (ITEM 626.333)	9.5 CY
FURNISH AND INSTALL CONTROLLER CABINET FOUNDATION (ITEM 626.35)	1
FURNISH AND INSTALL VIDEO DETECTION SYSTEM (ITEM 643.83)	1
FURNISH AND INSTALL POLE RISER (ITEM 643.90)	1
FURNISH AND INSTALL APPROXIMATELY 450 LINEAR FEET OF 12-STRAND FIBER OPTIC INTERCONNECT CABLE FROM CONTROLLER CABINET AT HARNOIS AVENUE AND MAIN STREET TO CONTROLLER CABINET (ITEM 643.90)	1
FURNISH AND INSTALL GALVANIZED STEEL TWIN MAST ARM POLE PAINTED BLACK WITH 25-FOOT AND 45-FOOT SIGNAL ARMS (ITEM 643.91)	1
FURNISH AND INSTALL GALVANIZED STEEL MAST ARM POLE PAINTED BLACK ENAMEL WITH 20-FOOT SIGNAL ARM (ITEM 643.91)	1
FURNISH AND INSTALL (8-FOOT) PEDESTAL POLE PAINTED BLACK ENAMEL (ITEM 643.92)	4
FURNISH AND INSTALL (10-FOOT) PEDESTAL POLE PAINTED BLACK ENAMEL (ITEM 643.92)	2

THE LISTED QUANTITIES ARE APPROXIMATE AND ARE FURNISHED FOR INFORMATION ONLY.

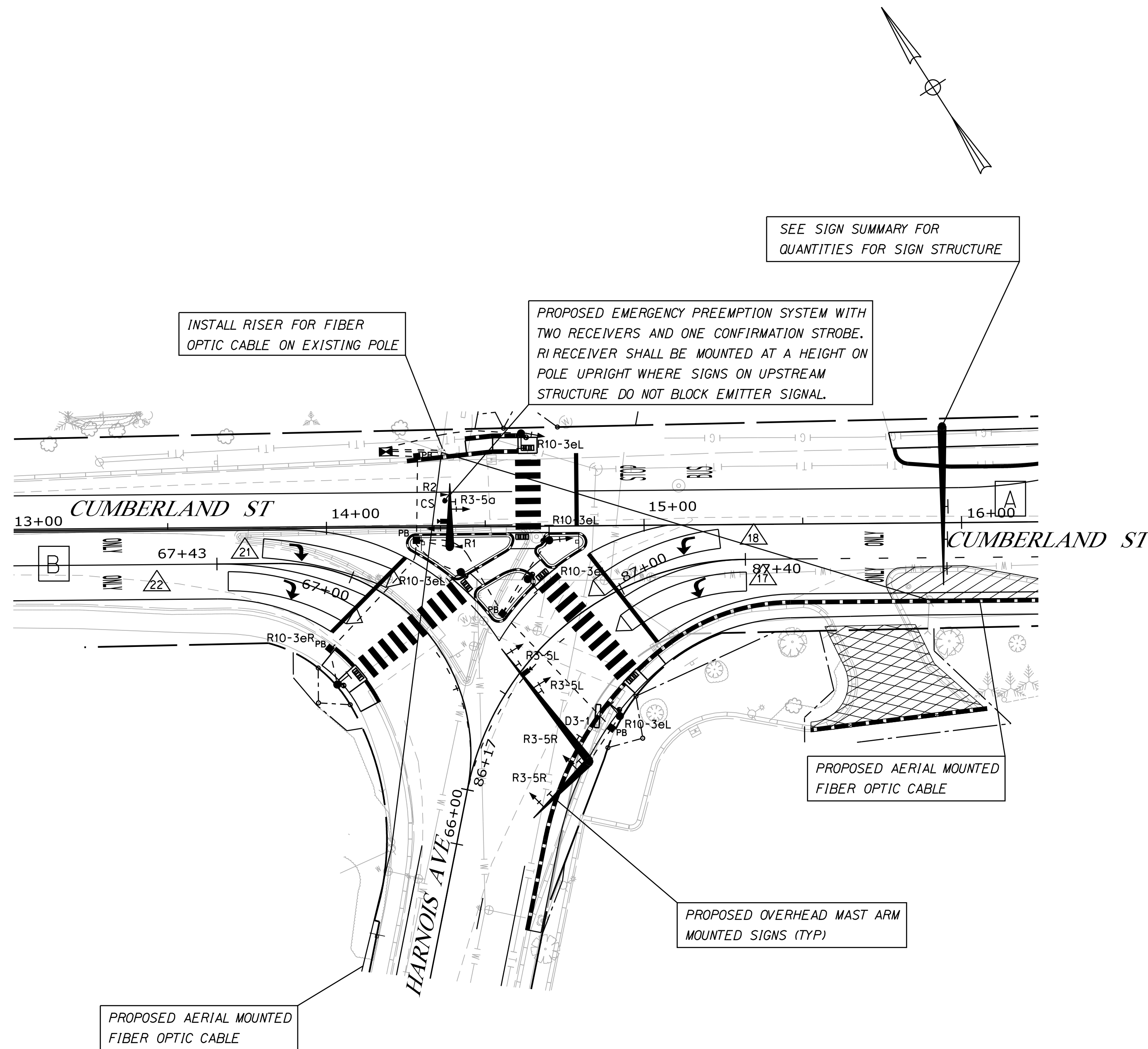

SEE SIGN SUMMARY FOR QUANTITIES FOR SIGN STRUCTURE

INSTALL RISER FOR FIBER OPTIC CABLE ON EXISTING POLE

PROPOSED EMERGENCY PREEMPTION SYSTEM WITH TWO RECEIVERS AND ONE CONFIRMATION STROBE. R1 RECEIVER SHALL BE MOUNTED AT A HEIGHT ON POLE UPRIGHT WHERE SIGNS ON UPSTREAM STRUCTURE DO NOT BLOCK EMITTER SIGNAL.

PROPOSED AERIAL MOUNTED FIBER OPTIC CABLE

PROPOSED OVERHEAD MAST ARM MOUNTED SIGNS (TYP)

PROPOSED AERIAL MOUNTED FIBER OPTIC CABLE

PROPOSED SIGNS

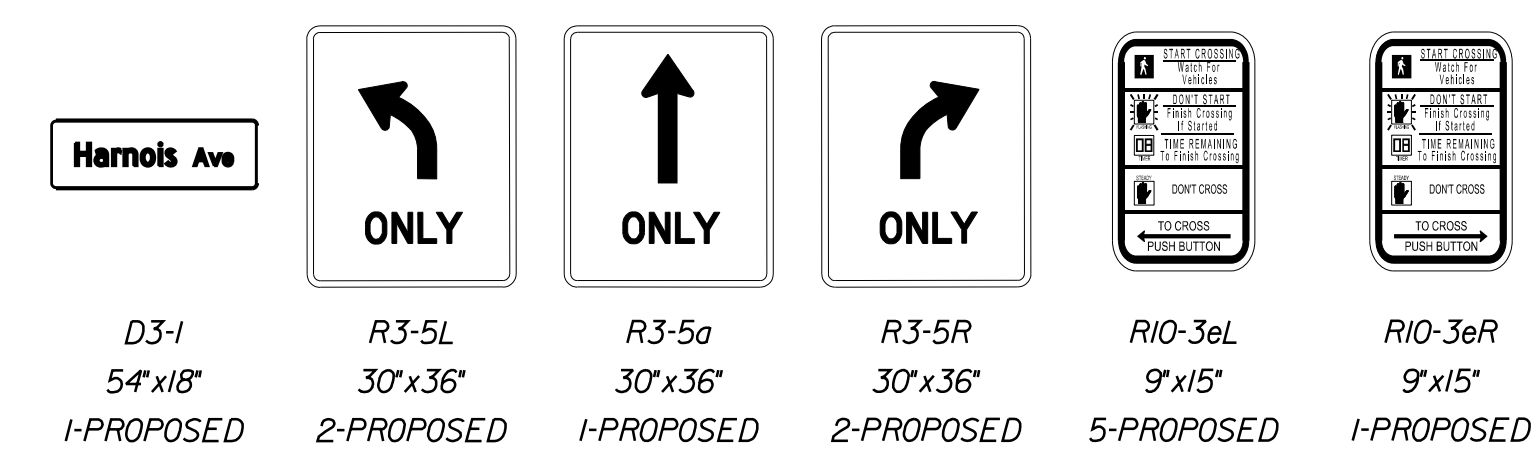

EMERGENCY VEHICLE PREEMPTION OPERATION

ID	PREEMPT ASSIGNMENT	RECEIVER PRIORITY	ACTIVE PHASE
R1	1	3	φ1 & φ6
R2	2	4	φ2 & φ6
		5	NOT USED
R2 (WARREN)		6	φ1 & φ6

EMERGENCY VEHICLE PRE-EMPTION NOTES:

- EMERGENCY VEHICLE PRE-EMPTION SIGNALS SHALL BE TRANSMITTED BY OPTICAL EMITTERS (PROVIDED BY OTHERS) MOUNTED IN EMERGENCY VEHICLES AND RECEIVED BY OPTICAL DETECTORS LOCATED AT THE INTERSECTION.
- PRE-EMPTION SIGNALS SHALL BE SERVICED ON A PRIORITY BASIS WITH RECEIVERS ASSIGNED DESCENDING PRIORITIES (3 = HIGHEST, 6 = LOWEST), NOTING 5 IS NOT USED.
- IN RESPONSE TO A PRE-EMPTION SIGNAL RECEIVED AT AN INTERSECTION BY AN OPTICAL DETECTOR, THE CONTROLLER SHALL HOLD OR ADVANCE TO AND HOLD THE EMERGENCY ACTIVE PHASE GREEN FOR A MINIMUM OF 10 SECONDS OR UNTIL THE PRE-EMPTION SIGNAL CEASES. THE CONTROLLER SHALL THEN TIME PRE-EMPTION PHASE CLEARANCE (3.0 SECONDS YELLOW AND 2.0 SECONDS ALL RED) AND SERVICE SUBSEQUENT EMERGENCY ACTIVE PHASES AS NECESSARY. AT THE COMPLETION OF THE PRE-EMPTION CYCLE, THE CONTROLLER SHALL TIME THE PRE-EMPTION CLEARANCE AND RESUME NORMAL SIGNAL OPERATION.
- MINIMUM GREEN AND NORMAL VEHICLE CLEARANCE SHALL BE PROVIDED ON PHASES THAT ARE TO BE TERMINATED BY PRE-EMPTION DEMAND.
- CONFIRMATION STROBES SHALL BE ILLUMINATED WHENEVER ANY EMERGENCY VEHICLE PREEMPTION GREEN IS ON.
- PREEMPTION SETTINGS SHALL BE PROGRAMMED SO THAT DURING PREEMPT, IF THE TRAFFIC CONTROLLER IS OPERATING UNDER COORDINATION THAT THE COORDINATION CONTINUES TO TIME IN THE BACKGROUND AND COORDINATED OPERATIONS RESUME FOLLOWING PREEMPTION WITHOUT CONTROLLER RESYNCHRONIZATION.
- φ1 & φ6 PREEMPTION SHALL BE CONNECTED TO AND TRIGGERED BY A WARREN AVENUE PREEMPTION.

LEGEND

	PROPOSED MAST ARM
	PROPOSED VEHICULAR HEAD WITH BACKPLATE
	PROPOSED PEDESTAL POLE
	PROPOSED PEDESTRIAN SIGNAL HEAD WITH APS PUSHBUTTON AND INFORMATIONAL SIGN
	PROPOSED CABINET WITH CONTROLLER
	PROPOSED ELECTRICAL JUNCTION BOX
	PROPOSED SIGNAL CONDUIT
	PROPOSED COMMUNICATIONS
	PROPOSED PREEMPTION RECEIVER
	PROPOSED CONFIRMATION STROBE
	PROPOSED VIDEO DETECTION ZONE
	PROPOSED VIDEO DETECTION CAMERA
	PROPOSED METER PEDESTAL

PLAN

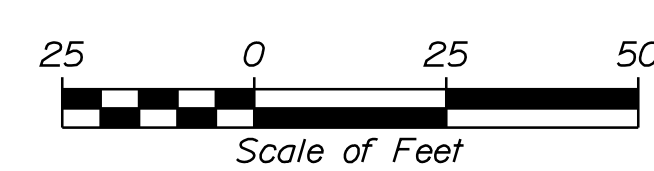

Date: 2/17/2020

Username: jrobert

Division: HIGHWAY

Filename: ... \HIGHWAY\MSTA\041_Signal_5.dgn

STATE OF MAINE
DEPARTMENT OF TRANSPORTATION
PROJECT NO. STP-1863(700)
WIN
18637.00
HIGHWAY PLANS



PROJ. MANAGER	B. KEEZER	DATE
DESIGN DETAILED	JAR	04/19
CHECKED/REVIEWED	CMB	04/19
M/G		
DESIGN REVIEWED		
DESIGN DETAILED		
REVISIONS 1		
REVISIONS 2		
REVISIONS 3		
REVISIONS 4		
FIELD CHANGES		

SIGNALIZATION OF
CUMBERLAND MILLS ROTARY
TRAFFIC SIGNAL PLAN
(4 OF 10)

SHEET NUMBER

41

OF 53

LIST OF MAJOR ITEMS

EQUIPMENT AND WORK ITEMS 643.80	QUANTITY	EQUIPMENT AND WORK ITEMS 643.80	QUANTITY
FURNISH AND INSTALL NEW P-TYPE BASE MOUNTED NEMA TS2, TYPE 1 METERED MAIN DOT SPEC CABINET PAINTED BLACK ENAMEL COMPLETE WITH GENERATOR TRANSFER SWITCH AND ALL ANCILLARY EQUIPMENT AND WIRING	1	FURNISH AND INSTALL PREEMPTION CONFIRMATION RED STROBE WITH CABLE	1
FURNISH AND INSTALL NEW NEMA ATC TRAFFIC SIGNAL CONTROLLER	1	FURNISH AND INSTALL 12-POSITION PATCH PANEL	1
FURNISH AND INSTALL NEW 16-CHANNEL ETHERNET EQUIPPED ENHANCED MALFUNCTION MANAGEMENT UNIT (MMU)	1	FURNISH AND INSTALL ENVIRONMENTALLY HARDENED FIBER OPTIC ETHERNET SWITCH WITH FIBER OPTIC INTERFACES	1
FURNISH AND INSTALL ONE-WAY, 3-SECTION, 12-INCH BLACK SIGNAL HEADS WITH LED MODULES WITH BLACK TUNNEL VISORS AND 5-INCH RETROREFLECTIVE LOUVERED BACKPLATES MOUNTED ON MAST ARMS WITH ASTROBRACKETS	4	FURNISH AND INSTALL MAST ARM AND BRACKET MOUNTED SIGNS	6
FURNISH AND INSTALL ONE-WAY, 3-SECTION, 12-INCH BLACK SIGNAL HEADS WITH LED MODULES WITH BLACK TUNNEL VISORS AND 5-INCH RETROREFLECTIVE LOUVERED BACKPLATES MOUNTED ON POST	1	FURNISH AND INSTALL ELECTRICAL SERVICE	1
FURNISH AND INSTALL ONE-WAY, 16 X 18 INCH LED BRACKET MOUNTED BLACK COUNTDOWN PEDESTRIAN SIGNAL HEADS	2	FURNISH AND INSTALL NEW SIGNAL CABLE	-
FURNISH AND INSTALL ONE-WAY, 16 X 18 INCH LED TOP OF POST MOUNTED BLACK COUNTDOWN PEDESTRIAN SIGNAL HEADS	2	FURNISH AND INSTALL PATCH CABLES AND IMPLEMENT REMOTE VIDEO, CONTROLLER, PREEMPTION, AND MMU COMMUNICATIONS TO EXISTING ADVANCED TRAFFIC MANAGEMENT SYSTEM	-
FURNISH AND INSTALL ADA COMPLIANT ACCESSIBLE PEDESTRIAN SIGNAL (APS) PUSH BUTTON WITH RIO-3E INFORMATIONAL SIGN	4	IMPLEMENT SYSTEM BASED AND LOCAL SIGNAL TIMINGS	-
FURNISH AND INSTALL 4-CHANNEL PREEMPTION PHASE SELECTOR WITH SYSTEM CHASSIS	1		
FURNISH AND INSTALL LIGHT-BASED PREEMPTION RECEIVERS WITH DETECTOR CABLE	2		

THE LISTED QUANTITIES ARE APPROXIMATE AND ARE FURNISHED FOR INFORMATION ONLY.

PROPOSED NEMA TS2-1 ETHERNET EQUIPPED ATC TRAFFIC SIGNAL CONTROLLER IN NEW METERED P-TYPE CABINET COMPLETE WITH ANCILLARY EQUIPMENT INCLUDING MMU, ETHERNET SWITCH AND PATCH PANEL MOUNTED ON A CONCRETE FOUNDATION. PROGRAM CONTROLLER WITH LOCAL AND SYSTEM TIMINGS. PROVIDE NEW WIRED FIBER OPTIC INTERCONNECT CABLE IMPLEMENT REMOTE VIDEO, CONTROLLER, PREEMPTION AND MMU COMMUNICATION TO EXISTING ATMS.

PROPOSED 8' PEDESTAL POST WITH PEDESTRIAN SIGNAL HEAD, APS PUSHBUTTON, AND RIO-3EL INFORMATIONAL SIGN

OVERHEAD SIGN MAST ARM. SEE SIGNING AND PAVEMENT MARKING PLANS FOR DETAILS

PROPOSED VIDEO DETECTION ZONES FOR PHASE 2

PROPOSED 10' PEDESTAL POST WITH VEHICULAR SIGNAL HEAD, PEDESTRIAN SIGNAL HEAD, APS PUSHBUTTON, AND RIO-3ER INFORMATIONAL SIGN

PROPOSED 30' MAST ARM POLE ON NEW FOUNDATION WITH PEDESTRIAN SIGNAL HEAD, APS PUSHBUTTON, AND RIO-3EL INFORMATIONAL SIGN

PROPOSED 30' MAST ARM POLE ON NEW FOUNDATION USE EXTRA LONG ASTROBRACKETS TO ENSURE SIGNAL HEADS ARE NOT BLOCKED

PROPOSED 8' PEDESTAL POST WITH PEDESTRIAN SIGNAL HEAD, APS PUSHBUTTON, AND RIO-3ER INFORMATIONAL SIGN

PROPOSED INDICATIONS

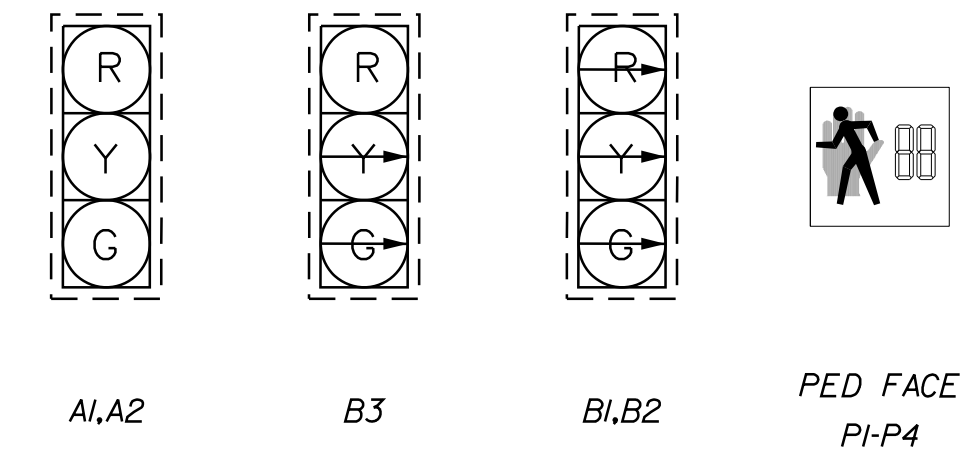

NOTE: ALL INDICATIONS SHALL BE 12" LIGHT EMITTING DIODES (LED'S) WITH 5" LOUVERED RETROREFLECTIVE BACKPLATES

PHASE DIAGRAM

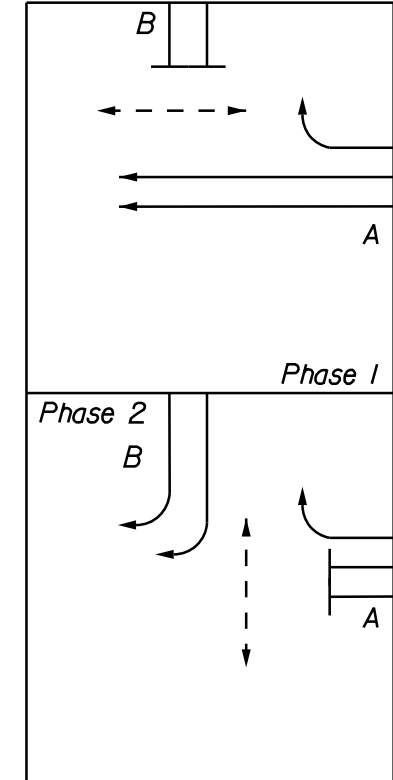

WHERE:
 → PROTECTED TRAFFIC MOVEMENT
 ⇄ PEDESTRIAN MOVEMENT

SIGNAL TIMING

	PHASE 1	PHASE 2
MINIMUM INITIAL	7	5
PASSAGE TIME	3.0	3.0
MAXIMUM 1	30	20
MAXIMUM 2	45	20
YELLOW	3.0	3.0
ALL RED	2.0	2.0
PED WALK	5	5
PED CLEAR	7	9
RECALL	SOFT	OFF
DETECTOR	PR	PR
PREEMPT PRIORITY	3.4	6
FLASH	Y	R
DUAL ENTRY	OFF	OFF

NOTE:
 1. IN THE EVENT OF A CONFLICT OR MALFUNCTION PHASE 1 SHALL FLASH YELLOW AND PHASE 2 SHALL FLASH RED. PEDESTRIAN SIGNAL HEADS SHALL BE BLANK DURING FLASHING OPERATIONS.
 2. PR - STOPLINE PRESENCE DETECTION.

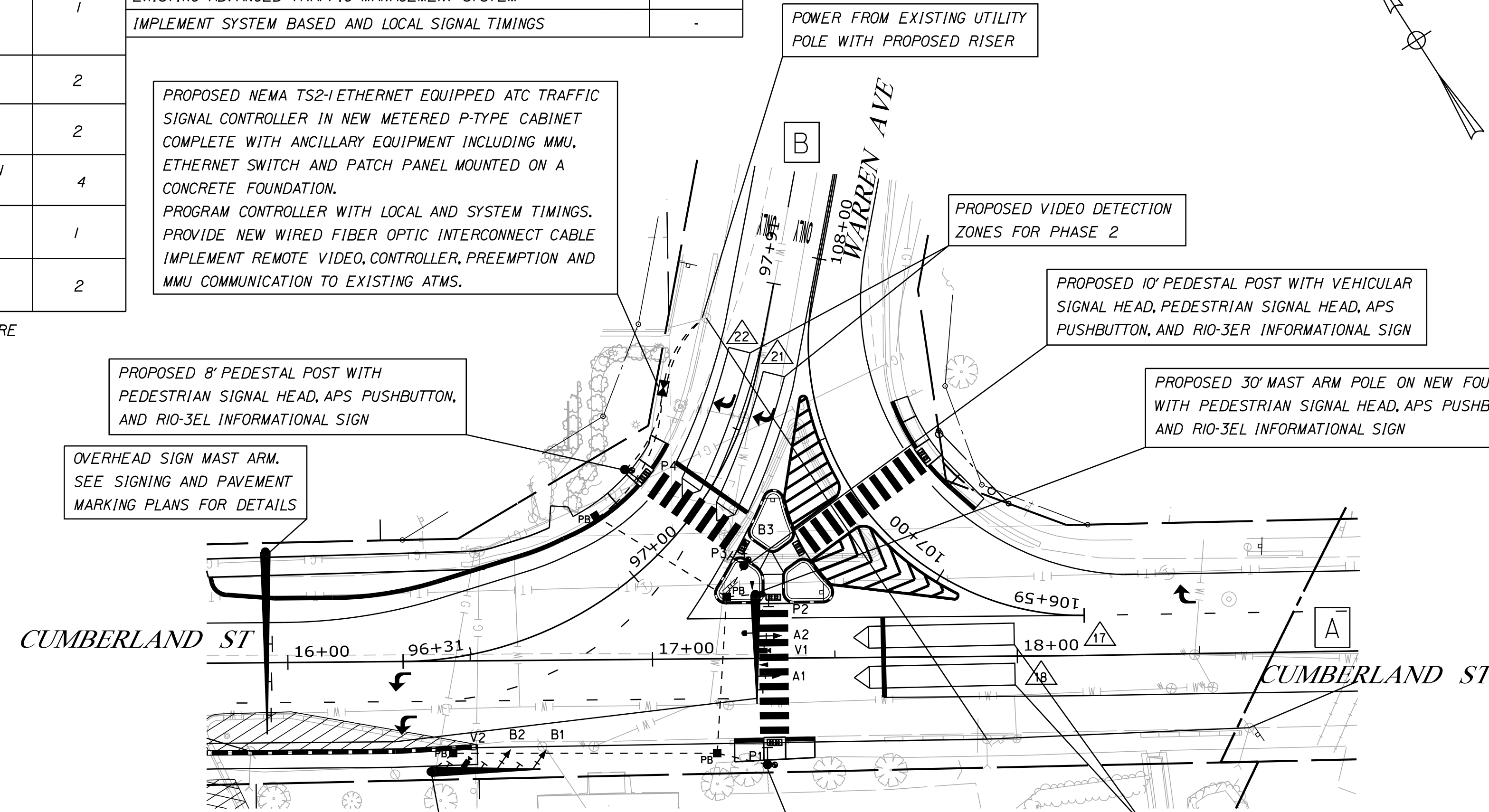

COORDINATION CYCLE/SPLIT/OFFSET SCHEDULE
 ALL ENTRIES IN SECONDS

	PLAN 1	PLAN 2	PLAN 3	PLAN 4	COORDINATION MODE SET TO FIXED FORCE-OFF
CYCLE LENGTH	65	70	75	80	
OFFSET (End Grn)	0	7	14	11	
COORDINATED ϕ	$\phi 1$	$\phi 1$	$\phi 1$	$\phi 1$	
SPLIT TIME $\phi 1$	30	35	25	28	
SPLIT TIME $\phi 2$	35	35	50	52	
SPLIT TIME $\phi 3$	0	0	0	0	
SPLIT TIME $\phi 4$	0	0	0	0	
SPLIT TIME $\phi 5$	0	0	0	0	
SPLIT TIME $\phi 6$	0	0	0	0	
SPLIT TIME $\phi 7$	0	0	0	0	
SPLIT TIME $\phi 8$	0	0	0	0	

COORDINATION NOTES:
 1. OFFSET IS REFERENCED TO THE END OF THE COORDINATED PHASE GREEN (SEE TABLE ABOVE).
 2. COORDINATION TO OPERATE BY TIME-OF-DAY (SEE DAILY AND WEEKLY COORDINATION SCHEDULE)

DETECTOR SCHEDULE

CAMERA	DETECTOR				DETECTOR CARD IN VEHICLE DETECTION RACK					
	PLAN ID	STREET	DIRECTION	LANE	ϕ	TYPE	SLOT NO	DETECTOR NO	CHANNEL	
VI	17	CUMBERLAND ST	WESTBOUND	THROUGH	1	FULL VIDEO THERMAL	1	17	1	
	18	CUMBERLAND ST	WESTBOUND	THROUGH	1				18	
	(19-20)	SPARE								
V2	21	WARREN AVE	SOUTHBOUND	RIGHT	2	FULL VIDEO THERMAL	1	21	2	
	22	WARREN AVE	SOUTHBOUND	RIGHT	2				22	
	(23-24)	SPARE								

DETECTOR NOTES:
 DETECTORS 1-16 SHALL BE CONNECTED TO DETECTOR PANEL TEST INPUT BUTTONS
 CONTRACTOR SHALL COMPLETE THE DETECTOR SCHEDULE FOR RECORD OF DETECTION PROGRAMMING INTO THE TRAFFIC SIGNAL CONTROLLER

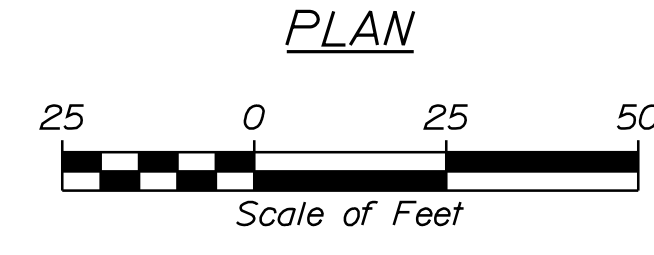

LEGEND

- PROPOSED MAST ARM
- PROPOSED VEHICULAR HEAD WITH BACKPLATE
- PROPOSED PEDESTAL POLE
- ⊥ PROPOSED PEDESTRIAN SIGNAL HEAD WITH APS PUSHBUTTON AND INFORMATIONAL SIGN
- ▣ PROPOSED CABINET WITH CONTROLLER
- PB ■ PROPOSED ELECTRICAL JUNCTION BOX
- - - PROPOSED SIGNAL CONDUIT
- PROPOSED COMMUNICATIONS
- ▲ PROPOSED PREEMPTION RECEIVER
- PROPOSED CONFIRMATION STROBE
- ⊔ PROPOSED VIDEO DETECTION ZONE
- PROPOSED VIDEO DETECTION CAMERA
- PROPOSED METER PEDESTAL



PROJ. MANAGER	B. KEEZER	DATE
DESIGN-DETAILED	MLC	04/19
CHECKED-REVIEWED	MIS	04/19
DESIGN-DETAILED	CMB	
DESIGN-DETAILED		
REVISIONS 1		
REVISIONS 2		
REVISIONS 3		
REVISIONS 4		
FIELD CHANGES		

SIGNALIZATION OF
 CUMBERLAND MILLS ROTARY
 TRAFFIC SIGNAL PLAN
 (5 OF 10)

SHEET NUMBER

42

OF 53

LIST OF MAJOR ITEMS

EQUIPMENT AND WORK ITEMS	QUANTITY
FURNISH AND INSTALL PRECAST JUNCTION BOX (ITEM 626.11)	4
FURNISH AND INSTALL METALLIC CONDUIT (ITEM 626.21)	25 LF
FURNISH AND INSTALL (3-INCH) NON-METALLIC CONDUIT (ITEM 626.22)	305 LF
FURNISH AND INSTALL 24-INCH FOUNDATION (ITEM 626.32)	3
FURNISH AND INSTALL 30-INCH DIAMETER, GREATER THAN 8-FEET LONG AND ALL 36-INCH AND 42-INCH DIAMETER FOUNDATIONS (ITEM 626.332)	8.5 CY
FURNISH AND INSTALL CONTROLLER CABINET FOUNDATION (ITEM 626.35)	1
FURNISH AND INSTALL VIDEO DETECTION SYSTEM (ITEM 643.83)	1
FURNISH AND INSTALL POLE RISER (ITEM 643.90)	1
FURNISH AND INSTALL APPROXIMATELY 665 LINEAR FEET OF 12-STRAND FIBER OPTIC INTERCONNECT CABLE FROM CONTROLLER CABINET AT CUMBERLAND STREET/ HARNOS AVENUE TO CONTROLLER CABINET (ITEM 643.90)	1
FURNISH AND INSTALL GALVANIZED STEEL MAST ARM POLE PAINTED BLACK ENAMEL WITH 30-FOOT SIGNAL ARM (ITEM 643.91)	2
FURNISH AND INSTALL (8-FOOT) PEDESTAL POLE PAINTED BLACK ENAMEL (ITEM 643.92)	2
FURNISH AND INSTALL (10-FOOT) PEDESTAL POLE PAINTED BLACK ENAMEL (ITEM 643.92)	1

THE LISTED QUANTITIES ARE APPROXIMATE AND ARE FURNISHED FOR INFORMATION ONLY.

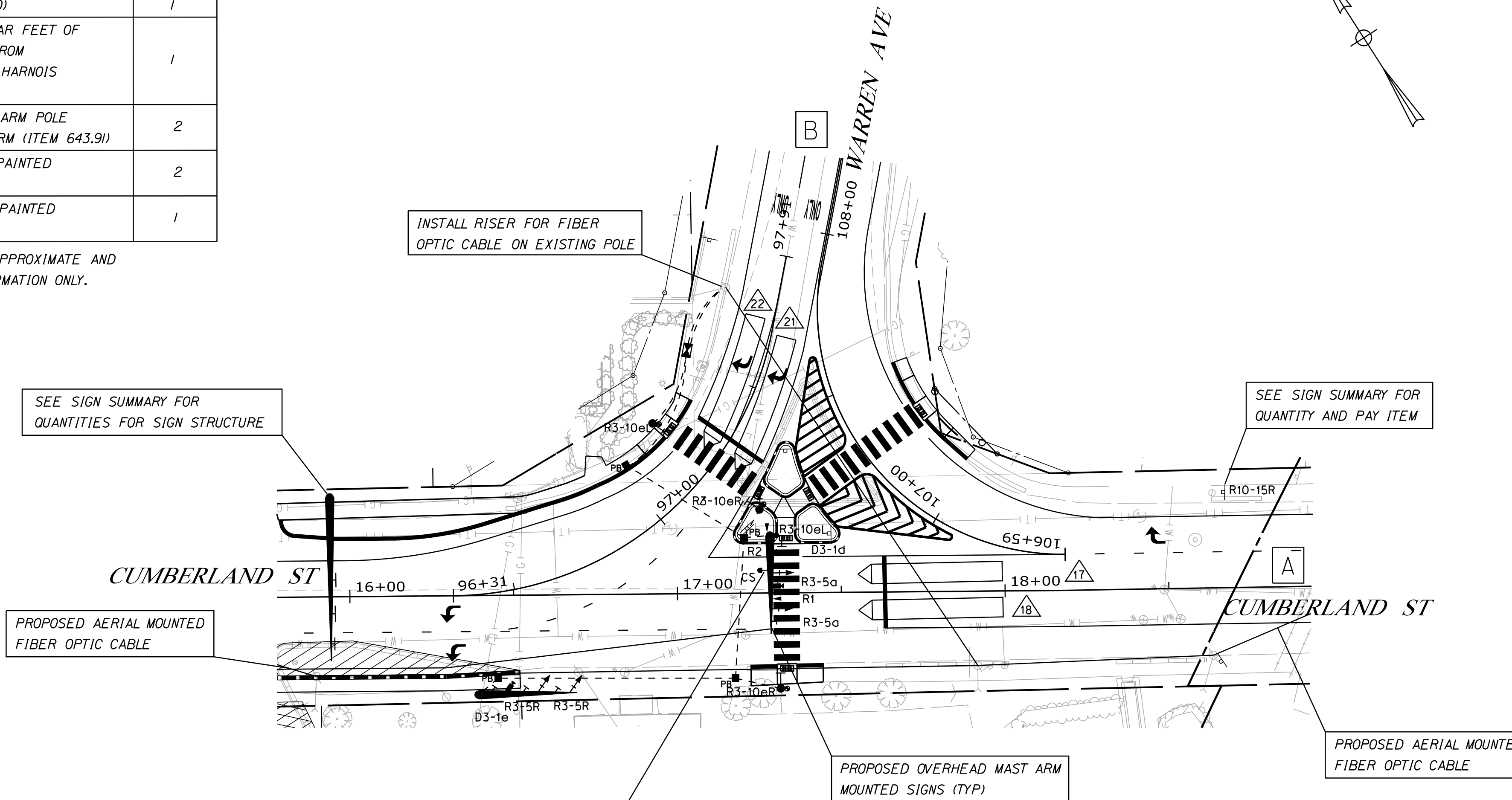

PROPOSED EMERGENCY PREEMPTION SYSTEM WITH TWO RECEIVERS AND ONE CONFIRMATION STROBE

PROPOSED SIGNS

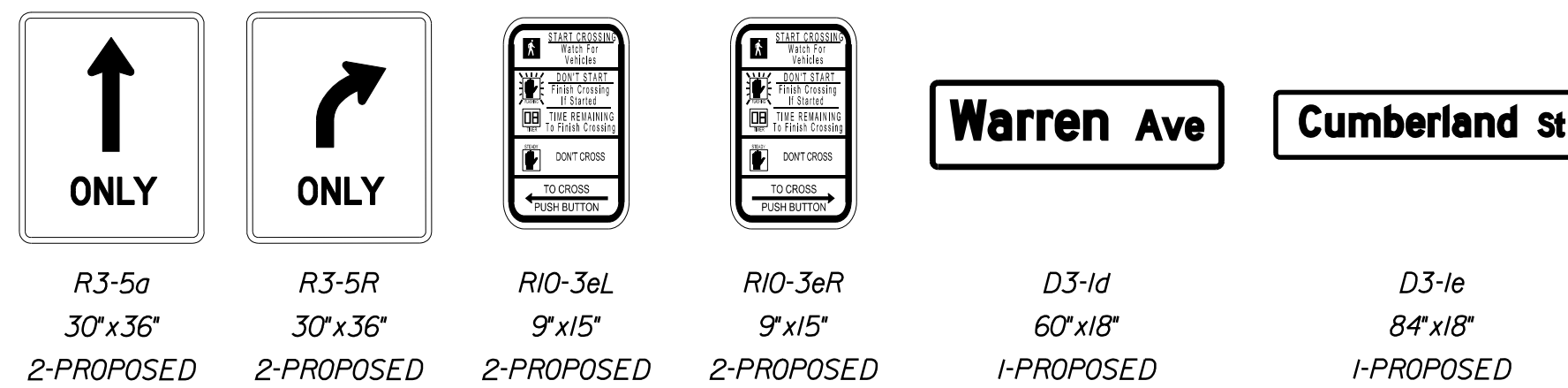

EMERGENCY VEHICLE PREEMPTION OPERATION

ID	PREEMPT ASSIGNMENT	RECEIVER PRIORITY	ACTIVE PHASE
R1	1	3	φ1
		4	φ1
		5	NOT USED
R2	2	6	φ2

EMERGENCY VEHICLE PRE-EMPTION NOTES:

- EMERGENCY VEHICLE PRE-EMPTION SIGNALS SHALL BE TRANSMITTED BY OPTICAL EMITTERS (PROVIDED BY OTHERS) MOUNTED IN EMERGENCY VEHICLES AND RECEIVED BY OPTICAL DETECTORS LOCATED AT THE INTERSECTION.
- PRE-EMPTION SIGNALS SHALL BE SERVICED ON A PRIORITY BASIS WITH RECEIVERS ASSIGNED DESCENDING PRIORITIES (3 = HIGHEST, 6 = LOWEST), NOTING 4 IS PROGRAMMED ASSIGNMENT ONLY AND 5 IS NOT USED.
- IN RESPONSE TO A PRE-EMPTION SIGNAL RECEIVED AT AN INTERSECTION BY AN OPTICAL DETECTOR, THE CONTROLLER SHALL HOLD OR ADVANCE TO AND HOLD THE EMERGENCY ACTIVE PHASE GREEN FOR A MINIMUM OF 10 SECONDS OR UNTIL THE PRE-EMPTION SIGNAL CEASES. THE CONTROLLER SHALL THEN TIME PRE-EMPTION PHASE CLEARANCE (3.0 SECONDS YELLOW AND 2.0 SECONDS ALL RED) AND SERVICE SUBSEQUENT EMERGENCY ACTIVE PHASES AS NECESSARY. AT THE COMPLETION OF THE PRE-EMPTION CYCLE, THE CONTROLLER SHALL TIME THE PRE-EMPTION CLEARANCE AND RESUME NORMAL SIGNAL OPERATION.
- MINIMUM GREEN AND NORMAL VEHICLE CLEARANCE SHALL BE PROVIDED ON PHASES THAT ARE TO BE TERMINATED BY PRE-EMPTION DEMAND.
- CONFIRMATION STROBES SHALL BE ILLUMINATED WHENEVER ANY EMERGENCY VEHICLE PREEMPTION GREEN IS ON.
- PREEMPTION SETTINGS SHALL BE PROGRAMMED SO THAT DURING PREEMPT, IF THE TRAFFIC CONTROLLER IS OPERATING UNDER COORDINATION THAT THE COORDINATION CONTINUES TO TIME IN THE BACKGROUND AND COORDINATED OPERATIONS RESUME FOLLOWING PREEMPTION WITHOUT CONTROLLER RESYNCHRONIZATION.
- φ2 PREEMPTION SHALL BE CONNECTED TO AND TRIGGER φ1 & φ6 PREEMPTION AT CUMBERLAND/HARNOS INTERSECTION.

LEGEND	
	PROPOSED MAST ARM
	PROPOSED VEHICULAR HEAD WITH BACKPLATE
	PROPOSED PEDESTAL POLE
	PROPOSED PEDESTRIAN SIGNAL HEAD WITH APS PUSHBUTTON AND INFORMATIONAL SIGN
	PROPOSED CABINET WITH CONTROLLER
	PROPOSED ELECTRICAL JUNCTION BOX
	PROPOSED SIGNAL CONDUIT
	PROPOSED COMMUNICATIONS
	PROPOSED PREEMPTION RECEIVER
	PROPOSED CONFIRMATION STROBE
	PROPOSED VIDEO DETECTION ZONE
	PROPOSED VIDEO DETECTION CAMERA
	PROPOSED METER PEDESTAL

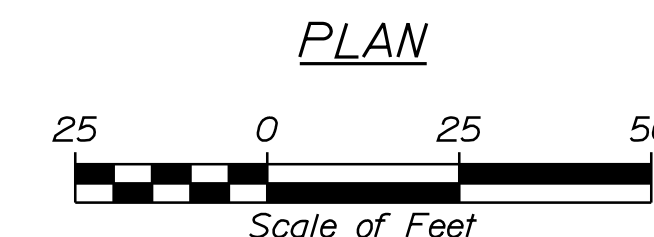

Date: 2/17/2020

Username: jrobert

Division: HIGHWAY

Filename: ... \HIGHWAY\MSTA\043_Signal_7.dgn

STATE OF MAINE
DEPARTMENT OF TRANSPORTATION
PROJECT NO. STP-1863(700)

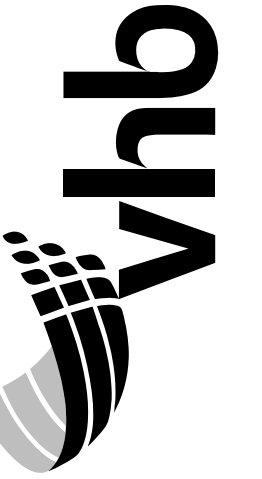

PROJ. MANAGER	B. KEEZER	DATE
DESIGN-DETAILED	MJC	04/19
CHECKED-REVIEWED	JAR	04/19
DESIGN-DETAILED	CMB	
DESIGN-DETAILED		
REVISIONS 1		
REVISIONS 2		
REVISIONS 3		
REVISIONS 4		
FIELD CHANGES		

SIGNALIZATION OF
CUMBERLAND MILLS ROTARY
TRAFFIC SIGNAL PLAN
(6 OF 10)

SHEET NUMBER
43
OF 53

HIGHWAY PLANS
WIN
18637.00

LIST OF MAJOR ITEMS

EQUIPMENT AND WORK ITEMS 643.80	QUANTITY	EQUIPMENT AND WORK ITEMS 643.80	QUANTITY
FURNISH AND INSTALL NEW P-TYPE BASE MOUNTED NEMA TS2, TYPE 1 METERED MAINE DOT SPEC CABINET PAINTED BLACK ENAMEL COMPLETE WITH GENERATOR TRANSFER SWITCH AND ALL ANCILLARY EQUIPMENT AND WIRING	1	FURNISH AND INSTALL PREEMPTION CONFIRMATION RED STROBE WITH CABLE	1
FURNISH AND INSTALL NEW NEMA ATC TRAFFIC SIGNAL CONTROLLER	1	FURNISH AND INSTALL 12-POSITION PATCH PANEL	1
FURNISH AND INSTALL NEW 16-CHANNEL ETHERNET EQUIPPED ENHANCED MALFUNCTION MANAGEMENT UNIT (MMU)	1	FURNISH AND INSTALL ENVIRONMENTALLY HARDENED FIBER OPTIC ETHERNET SWITCH WITH FIBER OPTIC INTERFACES	1
FURNISH AND INSTALL ONE-WAY, 3-SECTION, 12-INCH BLACK SIGNAL HEADS WITH LED MODULES WITH BLACK TUNNEL VISORS AND 5-INCH RETROREFLECTIVE LOUVERED BACKPLATES MOUNTED ON MAST ARMS WITH ASTROBRACKETS	7	FURNISH AND INSTALL MAST ARM AND BRACKET MOUNTED SIGNS	8
FURNISH AND INSTALL ONE-WAY, 3-SECTION, 12-INCH BLACK SIGNAL HEADS WITH LED MODULES WITH BLACK TUNNEL VISORS AND 5-INCH RETROREFLECTIVE LOUVERED BACKPLATES MOUNTED ON POST	1	FURNISH AND INSTALL ELECTRICAL SERVICE	1
FURNISH AND INSTALL ONE-WAY, 16 X 18 INCH LED BRACKET MOUNTED BLACK COUNTDOWN PEDESTRIAN SIGNAL HEADS	1	FURNISH AND INSTALL NEW SIGNAL CABLE	-
FURNISH AND INSTALL ONE-WAY, 16 X 18 INCH LED TOP OF POST MOUNTED BLACK COUNTDOWN PEDESTRIAN SIGNAL HEADS	5	FURNISH AND INSTALL PATCH CABLES AND IMPLEMENT REMOTE VIDEO, CONTROLLER, PREEMPTION, AND MMU COMMUNICATIONS TO EXISTING ADVANCED TRAFFIC MANAGEMENT SYSTEM	-
FURNISH AND INSTALL ADA COMPLIANT ACCESSIBLE PEDESTRIAN SIGNAL (APS) PUSH BUTTON WITH RIO-3E INFORMATIONAL SIGN	6	IMPLEMENT SYSTEM BASED AND LOCAL SIGNAL TIMINGS	-
FURNISH AND INSTALL 4-CHANNEL PREEMPTION PHASE SELECTOR WITH SYSTEM CHASSIS	1		
FURNISH AND INSTALL LIGHT-BASED PREEMPTION RECEIVERS WITH DETECTOR CABLE	2		

THE LISTED QUANTITIES ARE APPROXIMATE AND ARE FURNISHED FOR INFORMATION ONLY.

PROPOSED INDICATIONS

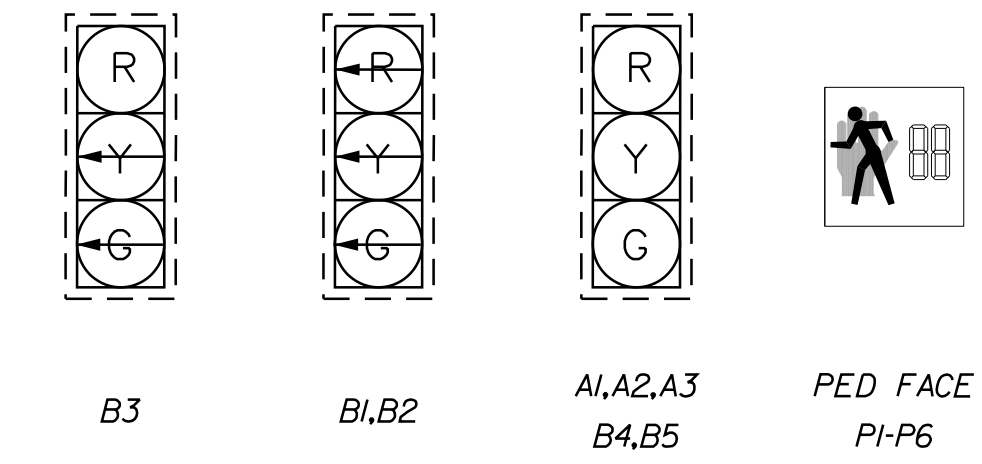

NOTE: ALL INDICATIONS SHALL BE 12" LIGHT EMITTING DIODES (LED'S) WITH 5" LOUVERED RETROREFLECTIVE BACKPLATES

PHASE DIAGRAM

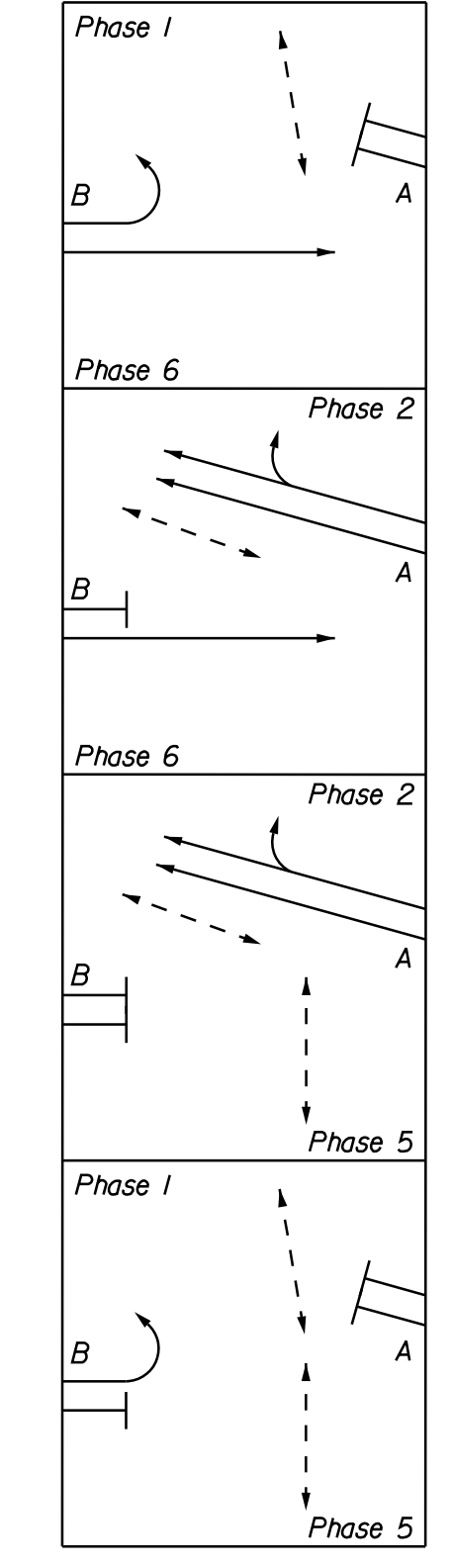

WHERE:
 -> PROTECTED TRAFFIC MOVEMENT
 - - -> PEDESTRIAN MOVEMENT

SIGNAL TIMING

	PHASE 1	PHASE 2	PHASE 5	PHASE 6
MINIMUM INITIAL PASSAGE TIME	7	7	5	7
MAXIMUM 1	25	25	13	40
MAXIMUM 2	25	35	13	50
YELLOW	3.0	3.0	3.0	3.0
ALL RED	2.0	2.0	0.0	2.0
PED WALK	5	5	5	-
PED CLEAR	10	12	7	-
RECALL	OFF	SOFT	OFF	SOFT
DETECTOR	PR	PR	PR	PR
PREEMPT PRIORITY	3	4	-	3,4
FLASH	R	Y	DARK	Y
DUAL ENTRY	OFF	ON	OFF	ON

NOTE:
 1. IN THE EVENT OF A CONFLICT OR MALFUNCTION PHASES 2 AND 6 SHALL FLASH YELLOW AND ALL OTHER PHASES SHALL FLASH RED. PEDESTRIAN SIGNAL HEADS SHALL BE BLANK DURING FLASHING OPERATIONS.
 2. PR = STOPLINE PRESENCE DETECTION.

DETECTOR SCHEDULE

	DETECTOR					DETECTOR CARD IN VEHICLE DETECTION RACK			
	PLAN ID	STREET	DIRECTION	LANE	φ	TYPE	SLOT NO	DETECTOR NO	CHANNEL
CAMERA V1	17	MAIN ST	EASTBOUND	LEFT	1	FULL VIDEO	1	17	1
	(18-20)	SPARE				THERMAL			
CAMERA V2	21	MAIN ST	WESTBOUND	THROUGH	2	FULL VIDEO	1	21	2
	(23-24)	SPARE				THERMAL		22	

DETECTOR NOTES:
 DETECTORS 1-16 SHALL BE CONNECTED TO DETECTOR PANEL TEST INPUT BUTTONS
 CONTRACTOR SHALL COMPLETE THE DETECTOR SCHEDULE FOR RECORD OF DETECTION PROGRAMMING INTO THE TRAFFIC SIGNAL CONTROLLER

COORDINATION CYCLE/SPLIT/OFFSET SCHEDULE
 ALL ENTRIES IN SECONDS

	PLAN 1	PLAN 2	PLAN 3	PLAN 4	COORDINATION MODE SET TO FIXED FORCE-OFF
CYCLE LENGTH	65	70	75	80	
OFFSET (End Grn)	0	0	0	0	
COORDINATED φ	φ 2	φ 2	φ 2	φ 2	
SPLIT TIME φ 1	31	35	30	32	
SPLIT TIME φ 2	34	35	45	48	
SPLIT TIME φ 3	0	0	0	0	
SPLIT TIME φ 4	0	0	0	0	
SPLIT TIME φ 5	17	17	17	17	
SPLIT TIME φ 6	48	53	58	63	
SPLIT TIME φ 7	0	0	0	0	
SPLIT TIME φ 8	0	0	0	0	

COORDINATION NOTES:
 1. OFFSET IS REFERENCED TO THE END OF THE COORDINATED PHASE GREEN (SEE TABLE ABOVE).
 2. COORDINATION TO OPERATE BY TIME-OF-DAY (SEE DAILY AND WEEKLY COORDINATION SCHEDULE)

PLAN

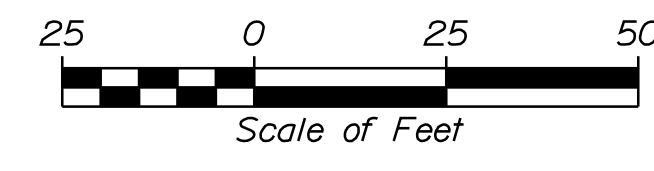

LEGEND

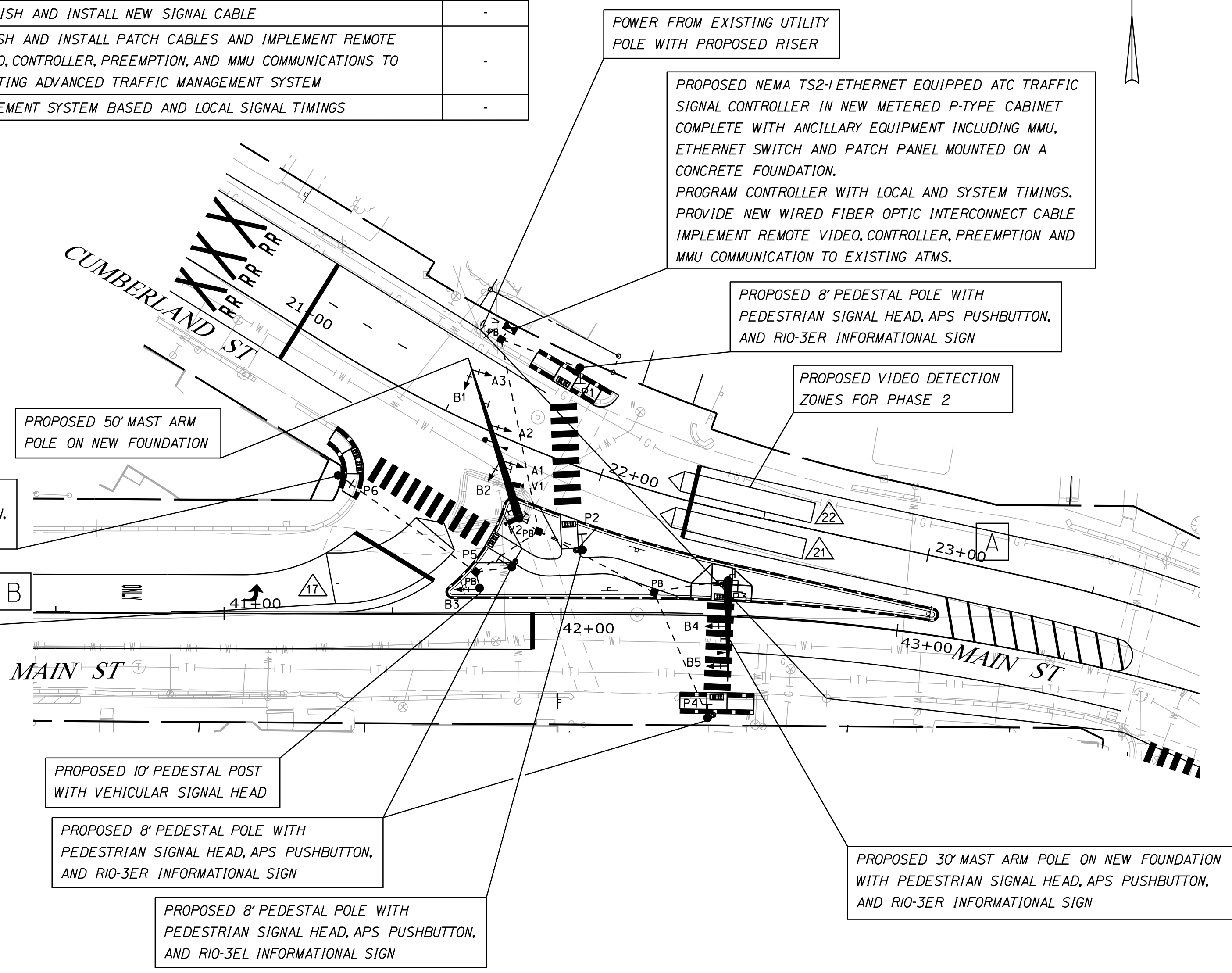
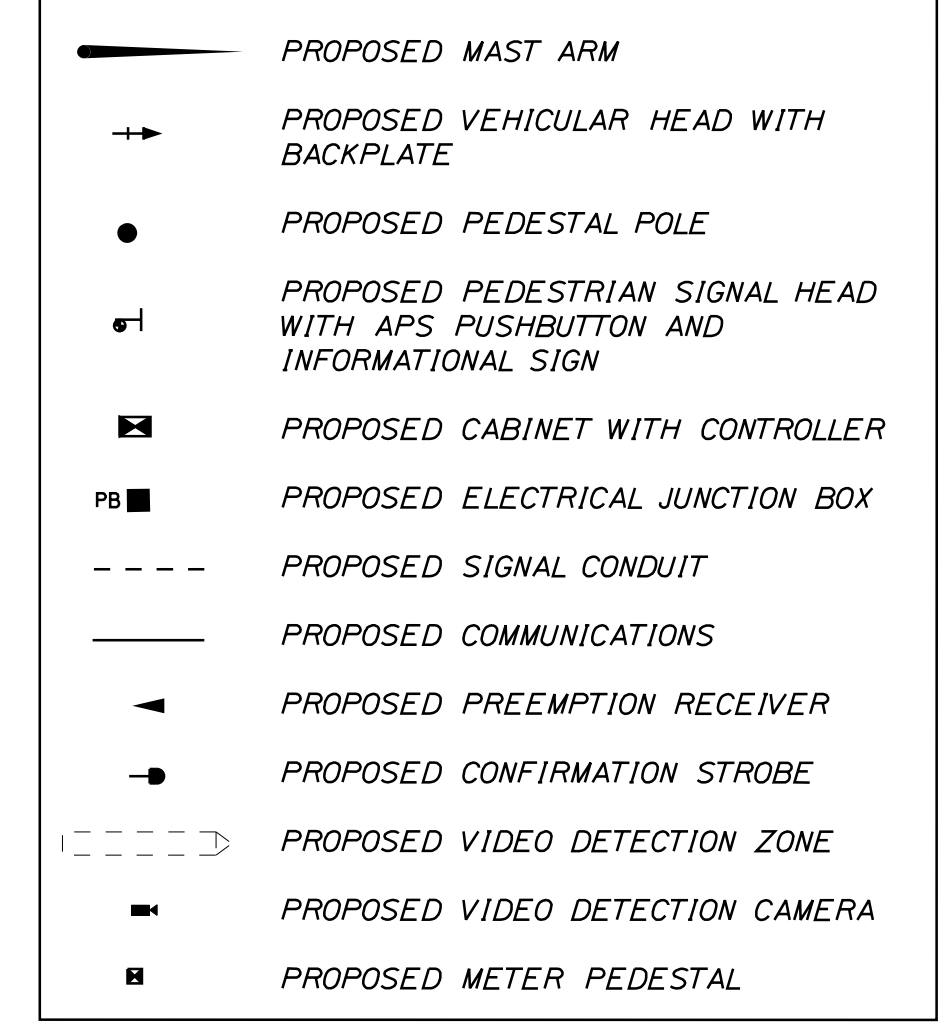

PROJ. MANAGER	B. KEEZER	DATE
DESIGN-DETAILED	JAR	04/19
CHECKED-REVIEWED	CMB	04/19
DESIGN-DETAILED		
DESIGN-DETAILED		
REVISIONS 1		
REVISIONS 2		
REVISIONS 3		
REVISIONS 4		
FIELD CHANGES		

SIGNALIZATION OF
 CUMBERLAND MILLS ROTARY
 TRAFFIC SIGNAL PLAN
 (7 OF 10)

LIST OF MAJOR ITEMS

EQUIPMENT AND WORK ITEMS	QUANTITY
FURNISH AND INSTALL PRECAST JUNCTION BOX (ITEM 626.11)	4
FURNISH AND INSTALL METALLIC CONDUIT (ITEM 626.21)	10 LF
FURNISH AND INSTALL (3-INCH) NON-METALLIC CONDUIT (ITEM 626.22)	315 LF
FURNISH AND INSTALL 24-INCH FOUNDATION (ITEM 626.32)	6
FURNISH AND INSTALL 30-INCH DIAMETER, GREATER THAN 8- FEET LONG AND ALL 36-INCH AND 42-INCH DIAMTER FOUNDATIONS (ITEM 626.332)	4.5 CY
FURNISH AND INSTALL 48-INCH DIAMETER, 54-INCH DIAMETER, 60-INCH DIAMETER FOUNDATIONS (ITEM 626.333)	6.5 CY
FURNISH AND INSTALL CONTROLLER CABINET FOUNDATION (ITEM 626.35)	1
FURNISH AND INSTALL VIDEO DETECTION SYSTEM (ITEM 643.83)	1
FURNISH AND INSTALL POLE RISER (ITEM 643.90)	1
FURNISH AND INSTALL APPROXIMATELY 660 LINEAR FEET OF 12-STRAND FIBER OPTIC INTERCONNECT CABLE FROM CONTROLLER CABINET AT CUMBERLAND STREET/ WARREN AVENUE TO CONTROLLER CABINET (ITEM 643.90)	1
FURNISH AND INSTALL GALVANIZED STEEL MAST ARM POLE PAINTED BLACK ENAMEL WITH 50-FOOT SIGNAL ARM (ITEM 643.91)	1
FURNISH AND INSTALL GALVANIZED STEEL MAST ARM POLE PAINTED BLACK ENAMEL WITH 30-FOOT SIGNAL ARM (ITEM 643.91)	1
FURNISH AND INSTALL (8-FOOT) PEDESTAL POLE PAINTED BLACK ENAMEL (ITEM 643.92)	5
FURNISH AND INSTALL (10-FOOT) PEDESTAL POLE PAINTED BLACK ENAMEL (ITEM 643.92)	1

THE LISTED QUANTITIES ARE APPROXIMATE AND ARE FURNISHED FOR INFORMATION ONLY.

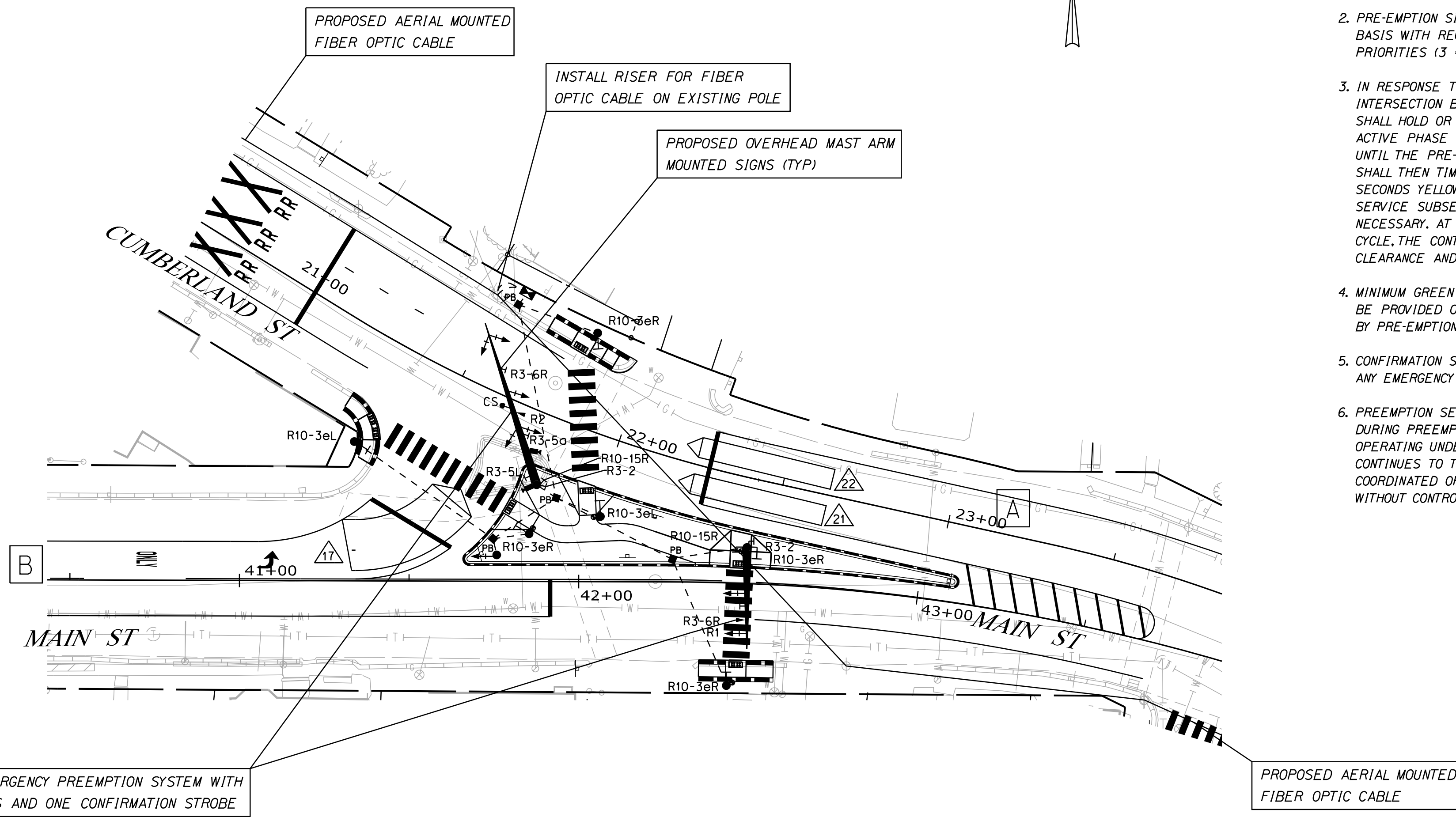

PROPOSED EMERGENCY PREEMPTION SYSTEM WITH TWO RECEIVERS AND ONE CONFIRMATION STROBE

PROPOSED AERIAL MOUNTED FIBER OPTIC CABLE

PROPOSED SIGNS

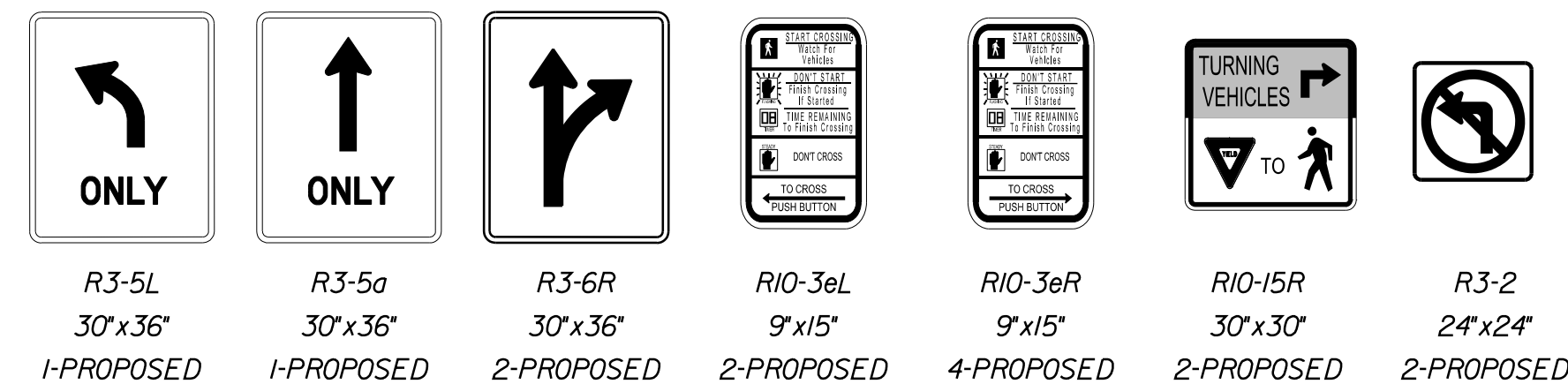

EMERGENCY VEHICLE PREEMPTION OPERATION

ID	PREEMPT ASSIGNMENT	RECEIVER PRIORITY	ACTIVE PHASE
R1	1	3	φ1 & φ6
R2	2	4	φ2 & φ6

- EMERGENCY VEHICLE PRE-EMPTION NOTES:**
- EMERGENCY VEHICLE PRE-EMPTION SIGNALS SHALL BE TRANSMITTED BY OPTICAL EMITTERS (PROVIDED BY OTHERS) MOUNTED IN EMERGENCY VEHICLES AND RECEIVED BY OPTICAL DETECTORS LOCATED AT THE INTERSECTION.
 - PRE-EMPTION SIGNALS SHALL BE SERVICED ON A PRIORITY BASIS WITH RECEIVERS ASSIGNED DESCENDING PRIORITIES (3 = HIGHEST, 4 = LOWEST)
 - IN RESPONSE TO A PRE-EMPTION SIGNAL RECEIVED AT AN INTERSECTION BY AN OPTICAL DETECTOR, THE CONTROLLER SHALL HOLD OR ADVANCE TO AND HOLD THE EMERGENCY ACTIVE PHASE GREEN FOR A MINIMUM OF 10 SECONDS OR UNTIL THE PRE-EMPTION SIGNAL CEASES. THE CONTROLLER SHALL THEN TIME PRE-EMPTION PHASE CLEARANCE (3.0 SECONDS YELLOW AND 2.0 SECONDS ALL RED) AND SERVICE SUBSEQUENT EMERGENCY ACTIVE PHASES AS NECESSARY. AT THE COMPLETION OF THE PRE-EMPTION CYCLE, THE CONTROLLER SHALL TIME THE PRE-EMPTION CLEARANCE AND RESUME NORMAL SIGNAL OPERATION.
 - MINIMUM GREEN AND NORMAL VEHICLE CLEARANCE SHALL BE PROVIDED ON PHASES THAT ARE TO BE TERMINATED BY PRE-EMPTION DEMAND.
 - CONFIRMATION STROBES SHALL BE ILLUMINATED WHENEVER ANY EMERGENCY VEHICLE PREEMPTION GREEN IS ON.
 - PREEMPTION SETTINGS SHALL BE PROGRAMMED SO THAT DURING PREEMPT, IF THE TRAFFIC CONTROLLER IS OPERATING UNDER COORDINATION THAT THE COORDINATION CONTINUES TO TIME IN THE BACKGROUND AND COORDINATED OPERATIONS RESUME FOLLOWING PREEMPTION WITHOUT CONTROLLER RESYNCHRONIZATION.

LEGEND	
	PROPOSED MAST ARM
	PROPOSED VEHICULAR HEAD WITH BACKPLATE
	PROPOSED PEDESTAL POLE
	PROPOSED PEDESTRIAN SIGNAL HEAD WITH APS PUSHBUTTON AND INFORMATIONAL SIGN
	PROPOSED CABINET WITH CONTROLLER
	PROPOSED ELECTRICAL JUNCTION BOX
	PROPOSED SIGNAL CONDUIT
	PROPOSED COMMUNICATIONS
	PROPOSED PREEMPTION RECEIVER
	PROPOSED CONFIRMATION STROBE
	PROPOSED VIDEO DETECTION ZONE
	PROPOSED VIDEO DETECTION CAMERA
	PROPOSED METER PEDESTAL

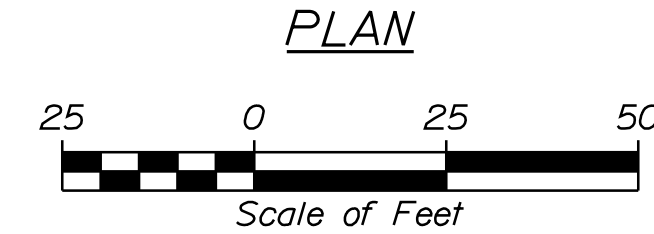

STATE OF MAINE
DEPARTMENT OF TRANSPORTATION

PROJECT NO. STP-1863(700)

HIGHWAY PLANS
WIN
18637.00

PROJ. MANAGER	B. KEEZER	DATE
DESIGN/DETAILED	MLC	04/19
CHECKED/REVIEWED	JAR	04/19
DESIGNED/DETAILED	CMB	
DESIGNED/DETAILED		
REVISIONS 1		
REVISIONS 2		
REVISIONS 3		
REVISIONS 4		
FIELD CHANGES		

SIGNALIZATION OF
CUMBERLAND MILLS ROTARY

TRAFFIC SIGNAL PLAN
(8 OF 10)

SHEET NUMBER

45

OF 53

Date: 2/17/2020

Username: jrobert

Division: HIGHWAY

Filename: ... \HIGHWAY\MSTA\045_Signal_9.dgn

LIST OF MAJOR ITEMS

EQUIPMENT AND WORK ITEMS 643.71	QUANTITY	EQUIPMENT AND WORK ITEMS 643.71	QUANTITY
FURNISH AND INSTALL NEW P-TYPE BASE MOUNTED NEMA TS2, TYPE 1 METERED MAINEDOT SPEC CABINET PAINTED BLACK ENAMEL COMPLETE WITH GENERATOR TRANSFER SWITCH AND ALL ANCILLARY EQUIPMENT AND WIRING	1	FURNISH AND INSTALL PREEMPTION CONFIRMATION RED STROBE WITH CABLE	1
FURNISH AND INSTALL NEW NEMA ATC TRAFFIC SIGNAL CONTROLLER	1	FURNISH AND INSTALL 12-POSITION PATCH PANEL	1
FURNISH AND INSTALL NEW 16-CHANNEL ETHERNET EQUIPPED ENHANCED MALFUNCTION MANAGEMENT UNIT (MMU)	1	FURNISH AND INSTALL ENVIRONMENTALLY HARDENED FIBER OPTIC ETHERNET SWITCH WITH FIBER OPTIC INTERFACES	1
FURNISH AND INSTALL ONE-WAY, 3-SECTION, 12-INCH BLACK SIGNAL HEADS WITH LED MODULES WITH BLACK TUNNEL VISORS AND 5-INCH RETROREFLECTIVE LOUVERED BACKPLATES MOUNTED ON MAST ARMS WITH ASTROBRACKETS	8	FURNISH AND INSTALL MAST ARM AND BRACKET MOUNTED SIGNS	12
FURNISH AND INSTALL ONE-WAY, 16 X 18 INCH LED BRACKET MOUNTED BLACK COUNTDOWN PEDESTRIAN SIGNAL HEADS	4	FURNISH AND INSTALL ELECTRICAL SERVICE	1
FURNISH AND INSTALL ONE-WAY, 16 X 18 INCH LED TOP OF POST MOUNTED BLACK COUNTDOWN PEDESTRIAN SIGNAL HEADS	4	FURNISH AND INSTALL NEW SIGNAL CABLE	-
FURNISH AND INSTALL ADA COMPLIANT ACCESSIBLE PEDESTRIAN SIGNAL (APS) PUSH BUTTON WITH RIO-3E INFORMATIONAL SIGN	8	FURNISH AND INSTALL PATCH CABLES AND IMPLEMENT REMOTE VIDEO, CONTROLLER, PREEMPTION, AND MMU COMMUNICATIONS TO EXISTING ADVANCED TRAFFIC MANAGEMENT SYSTEM	-
FURNISH AND INSTALL 4-CHANNEL PREEMPTION PHASE SELECTOR WITH SYSTEM CHASSIS	1	IMPLEMENT SYSTEM BASED AND LOCAL SIGNAL TIMINGS	-
FURNISH AND INSTALL LIGHT-BASED PREEMPTION RECEIVERS WITH DETECTOR CABLE	4		

THE LISTED QUANTITIES ARE APPROXIMATE AND ARE FURNISHED FOR INFORMATION ONLY.

PHASE DIAGRAM

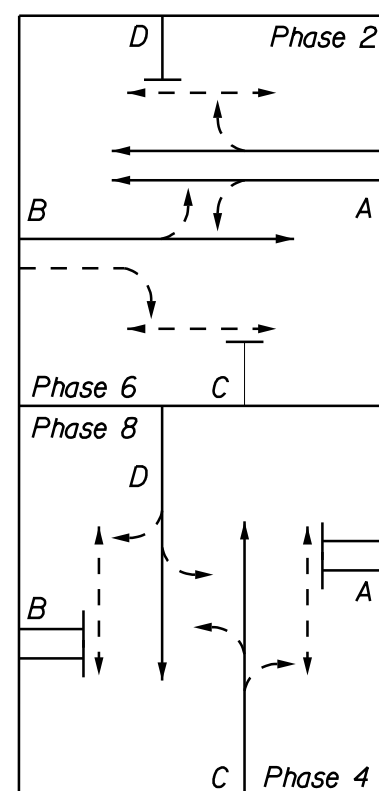

WHERE:

- PROTECTED TRAFFIC MOVEMENT
- - - PERMISSIVE TRAFFIC MOVEMENT
- ↔ CONCURRENT PEDESTRIAN MOVEMENT UPON PUSHBUTTON ACTIVATION

DETECTOR SCHEDULE

	DETECTOR				DETECTOR CARD IN VEHICLE DETECTION RACK				
	PLAN ID	STREET	DIRECTION	LANE	φ	TYPE	SLOT NO	DETECTOR NO	CHANNEL
CAMERA V1	17	MAIN ST	WESTBOUND	LEFT-THROUGH	2	FULL VIDEO THERMAL	1	17	1
	18	MAIN ST	WESTBOUND	THROUGH-RIGHT	2		1	18	1
	(19-20)	SPARE							
CAMERA V2	21	MAIN ST	EASTBOUND	LEFT-THROUGH	6	FULL VIDEO THERMAL	1	21	2
	22	MAIN ST	EASTBOUND	RIGHT	6		1	22	2
	(23-24)	SPARE							
CAMERA V3	25	FOREST ST	NORTHBOUND	LEFT-THRU-RIGHT	4	FULL VIDEO THERMAL	1	25	1
	(26-28)	SPARE							
CAMERA V4	29	FOREST ST	SOUTHBOUND	LEFT-THRU-RIGHT	8	FULL VIDEO THERMAL	1	29	1

DETECTOR NOTES:

DETECTORS 1-16 SHALL BE CONNECTED TO DETECTOR PANEL TEST INPUT BUTTONS. CONTRACTOR SHALL COMPLETE THE DETECTOR SCHEDULE FOR RECORD OF DETECTION PROGRAMMING INTO THE TRAFFIC SIGNAL CONTROLLER.

COORDINATION CYCLE/SPLIT/OFFSET SCHEDULE

	PLAN 1	PLAN 2	PLAN 3	PLAN 4	COORDINATION MODE SET TO FIXED FORCE-OFF
CYCLE LENGTH	65	70	75	80	
OFFSET (End Grn)	54	62	59	70	
COORDINATED φ	φ 2	φ 2	φ 2	φ 2	
SPLIT TIME φ 1	0	0	0	0	
SPLIT TIME φ 2	38	45	45	48	
SPLIT TIME φ 3	0	0	0	0	
SPLIT TIME φ 4	27	25	30	32	
SPLIT TIME φ 5	0	0	0	0	
SPLIT TIME φ 6	38	45	45	48	
SPLIT TIME φ 7	0	0	0	0	
SPLIT TIME φ 8	27	25	30	32	

COORDINATION NOTES:

- OFFSET IS REFERENCED TO THE END OF THE COORDINATED PHASE GREEN (SEE TABLE ABOVE).
- COORDINATION TO OPERATE BY TIME-OF-DAY (SEE DAILY AND WEEKLY COORDINATION SCHEDULE)

PLAN

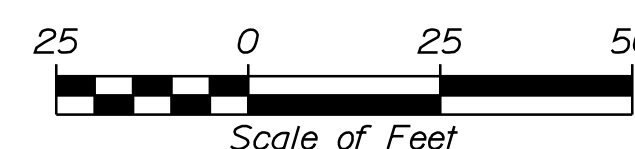

PROPOSED INDICATIONS

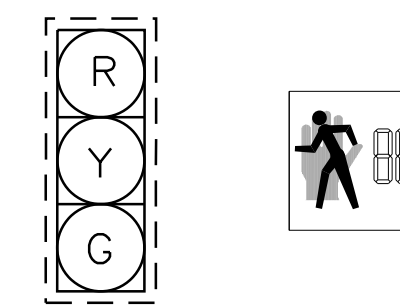

A1,A2,B1,B2
C1,C2,D1,D2
PED FACE
PI-P8

NOTE:

ALL INDICATIONS SHALL BE 12" LIGHT EMITTING DIODES (LED'S) WITH 5" LOUVERED RETROREFLECTIVE BACKPLATES

SIGNAL TIMING

	PHASE 2	PHASE 4	PHASE 6	PHASE 8
MINIMUM INITIAL PASSAGE TIME	7	5	7	5
MAXIMUM 1	37	18	37	18
MAXIMUM 2	50	45	50	45
YELLOW	3.0	3.0	3.0	3.0
ALL RED	2.0	2.0	2.0	2.0
PED WALK	7	5	7	5
PED CLEAR	10	13	10	13
RECALL	SOFT	OFF	SOFT	OFF
DETECTOR	PR	PR	PR	PR
PREEMPT PRIORITY	4	5	3	6
FLASH	Y	R	Y	R
DUAL ENTRY	ON	ON	ON	ON

NOTE:

- IN THE EVENT OF A CONFLICT OR MALFUNCTION PHASES 2 AND 6 SHALL FLASH YELLOW AND ALL OTHER PHASES SHALL FLASH RED. PEDESTRIAN SIGNAL HEADS SHALL BE BLANK DURING FLASHING OPERATIONS.
- PR = STOPLINE PRESENCE DETECTION.

LEGEND

- PROPOSED MAST ARM
- PROPOSED VEHICULAR HEAD WITH BACKPLATE
- PROPOSED PEDESTAL POLE
- ⊥ PROPOSED PEDESTRIAN SIGNAL HEAD WITH APS PUSHBUTTON AND INFORMATIONAL SIGN
- ▣ PROPOSED CABINET WITH CONTROLLER
- PB ■ PROPOSED ELECTRICAL JUNCTION BOX
- - - PROPOSED SIGNAL CONDUIT
- PROPOSED COMMUNICATIONS
- ▲ PROPOSED PREEMPTION RECEIVER
- PROPOSED CONFIRMATION STROBE
- PROPOSED VIDEO DETECTION ZONE
- PROPOSED VIDEO DETECTION CAMERA
- PROPOSED METER PEDESTAL

STATE OF MAINE
DEPARTMENT OF TRANSPORTATION
PROJECT NO. STP-1863(700)
WIN 18637.00
HIGHWAY PLANS

vhb

PROJ. MANAGER	DATE	BY	REVISIONS
DESIGN DETAILED	04/19	JAR	1
CHECKED/REVIEWED	04/19	CMB	2
DESIGNS DETAILED			3
REVISIONS 1			4
REVISIONS 2			5
REVISIONS 3			6
REVISIONS 4			7
FIELD CHANGES			8

SIGNALIZATION OF
CUMBERLAND MILLS ROTARY
TRAFFIC SIGNAL PLAN
(9 OF 10)

SHEET NUMBER
46
OF 53

LIST OF MAJOR ITEMS

EQUIPMENT AND WORK ITEMS	QUANTITY
FURNISH AND INSTALL PRECAST JUNCTION BOX (ITEM 626.11)	5
FURNISH AND INSTALL METALLIC CONDUIT (ITEM 626.21)	70 LF
FURNISH AND INSTALL (3-INCH) NON-METALLIC CONDUIT (ITEM 626.22)	345 LF
FURNISH AND INSTALL 24-INCH FOUNDATION (ITEM 626.32)	4
FURNISH AND INSTALL 30-INCH DIAMETER, GREATER THAN 8-FEET LONG AND ALL 36-INCH AND 42-INCH DIAMETER FOUNDATIONS (ITEM 626.332)	15 CY
FURNISH AND INSTALL CONTROLLER CABINET FOUNDATION (ITEM 626.35)	1
FURNISH AND INSTALL VIDEO DETECTION SYSTEM (ITEM 643.83)	1
FURNISH AND INSTALL POLE RISER (ITEM 643.90)	1
FURNISH AND INSTALL APPROXIMATELY 1150 LINEAR FEET OF 12-STRAND FIBER OPTIC INTERCONNECT CABLE FROM CONTROLLER CABINET AT MAIN STRET/ CUMBERLAND STREET TO CONTROLLER CABINET (ITEM 643.90)	1
FURNISH AND INSTALL GALVANIZED STEEL MAST ARM POLE PAINTED BLACK ENAMEL WITH 20-FOOT SIGNAL ARM (ITEM 643.91)	1
FURNISH AND INSTALL GALVANIZED STEEL MAST ARM POLE PAINTED BLACK ENAMEL WITH 25-FOOT SIGNAL ARM (ITEM 643.91)	1
FURNISH AND INSTALL GALVANIZED STEEL MAST ARM POLE PAINTED BLACK ENAMEL WITH 30-FOOT SIGNAL ARM (ITEM 643.91)	2
FURNISH AND INSTALL (8-FOOT) PEDESTAL POLE PAINTED BLACK ENAMEL (ITEM 643.92)	4

THE LISTED QUANTITIES ARE APPROXIMATE AND ARE FURNISHED FOR INFORMATION ONLY.

SIGNAL PLAN NOTES:

- THE COST FOR REMOVAL OF THE EXISTING SPAN WIRE AND SUPPORT POLES SHALL BE INCIDENTAL TO ITEM 643.71.

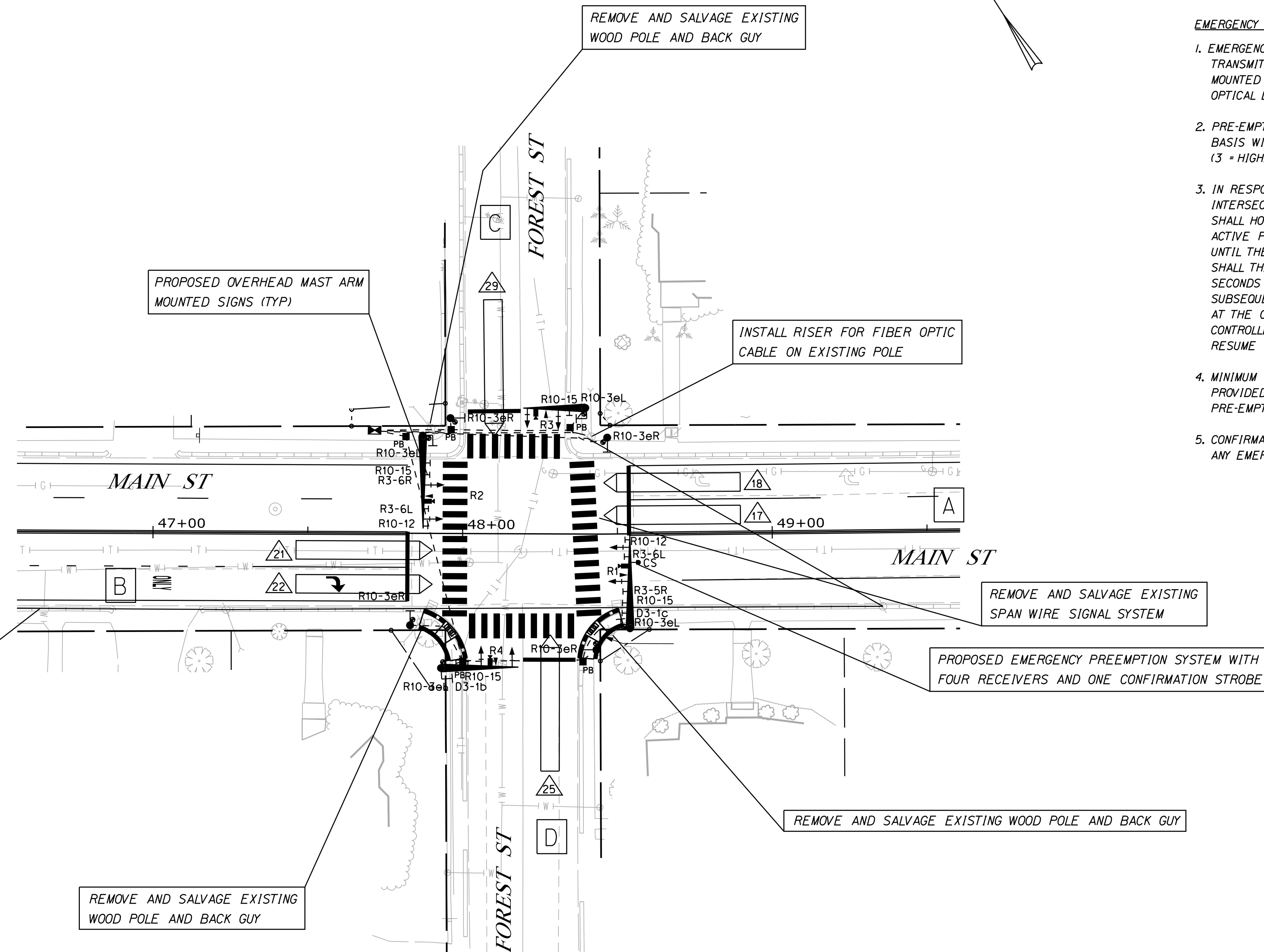

PROPOSED AERIAL MOUNTED FIBER OPTIC CABLE

REMOVE AND SALVAGE EXISTING WOOD POLE AND BACK GUY

PROPOSED SIGNS

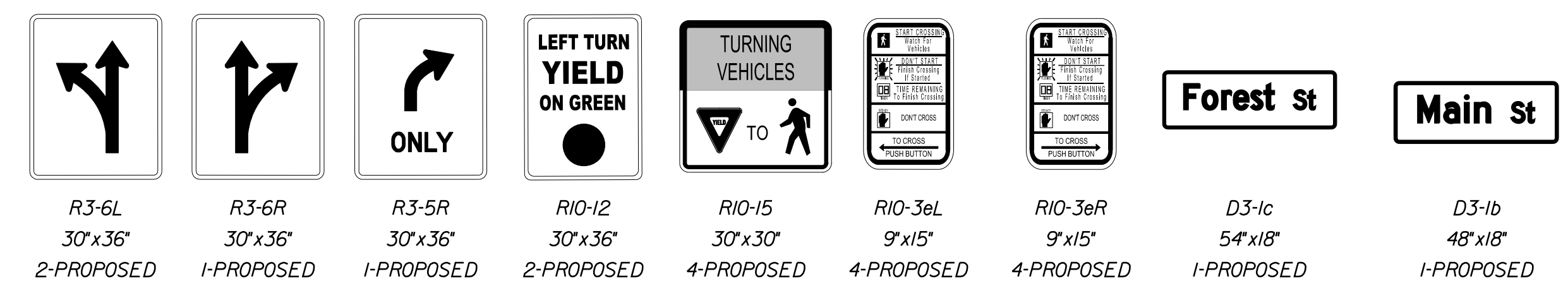

EMERGENCY VEHICLE PREEMPTION OPERATION

ID	PREEMPT ASSIGNMENT	RECEIVER PRIORITY	ACTIVE PHASE
R1	1	3	φ 6
R2	2	4	φ 2
R3	3	5	φ 4
R4	4	6	φ 8

EMERGENCY VEHICLE PRE-EMPTION NOTES:

- EMERGENCY VEHICLE PRE-EMPTION SIGNALS SHALL BE TRANSMITTED BY OPTICAL EMITTERS (PROVIDED BY OTHERS) MOUNTED IN EMERGENCY VEHICLES AND RECEIVED BY OPTICAL DETECTORS LOCATED AT THE INTERSECTION.
- PRE-EMPTION SIGNALS SHALL BE SERVICED ON A PRIORITY BASIS WITH RECEIVERS ASSIGNED DESCENDING PRIORITIES (3 = HIGHEST, 6 = LOWEST)
- IN RESPONSE TO A PRE-EMPTION SIGNAL RECEIVED AT AN INTERSECTION BY AN OPTICAL DETECTOR, THE CONTROLLER SHALL HOLD OR ADVANCE TO AND HOLD THE EMERGENCY ACTIVE PHASE GREEN FOR A MINIMUM OF 10 SECONDS OR UNTIL THE PRE-EMPTION SIGNAL CEASES. THE CONTROLLER SHALL THEN TIME PRE-EMPTION PHASE CLEARANCE (3.0 SECONDS YELLOW AND 2.0 SECONDS ALL RED) AND SERVICE SUBSEQUENT EMERGENCY ACTIVE PHASES AS NECESSARY. AT THE COMPLETION OF THE PRE-EMPTION CYCLE, THE CONTROLLER SHALL TIME THE PRE-EMPTION CLEARANCE AND RESUME NORMAL SIGNAL OPERATION.
- MINIMUM GREEN AND NORMAL VEHICLE CLEARANCE SHALL BE PROVIDED ON PHASES THAT ARE TO BE TERMINATED BY PRE-EMPTION DEMAND.
- CONFIRMATION STROBES SHALL BE ILLUMINATED WHENEVER ANY EMERGENCY VEHICLE PREEMPTION GREEN IS ON.

LEGEND	
	PROPOSED MAST ARM
	PROPOSED VEHICULAR HEAD WITH BACKPLATE
	PROPOSED PEDESTAL POLE
	PROPOSED PEDESTRIAN SIGNAL HEAD WITH APS PUSHBUTTON AND INFORMATIONAL SIGN
	PROPOSED CABINET WITH CONTROLLER
	PROPOSED ELECTRICAL JUNCTION BOX
	PROPOSED SIGNAL CONDUIT
	PROPOSED COMMUNICATIONS
	PROPOSED PREEMPTION RECEIVER
	PROPOSED CONFIRMATION STROBE
	PROPOSED VIDEO DETECTION ZONE
	PROPOSED VIDEO DETECTION CAMERA
	PROPOSED METER PEDESTAL

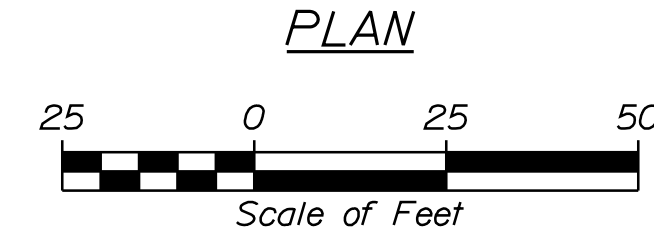

Date: 2/17/2020

Username: jrobert

Division: HIGHWAY

Filename: ... \HIGHWAY\MSTA\047_Signal_11.dgn

STATE OF MAINE
DEPARTMENT OF TRANSPORTATION
PROJECT NO. STP-1863(700)
WIN
18637.00
HIGHWAY PLANS



PROJ. MANAGER	B. KEEZER	DATE
DESIGN DETAILED	MLC	04/19
CHECKED/REVIEWED	JAR	04/19
DESIGN DETAILED	CMB	
DESIGN DETAILED		
REVISIONS 1		
REVISIONS 2		
REVISIONS 3		
REVISIONS 4		
FIELD CHANGES		

SIGNALIZATION OF
CUMBERLAND MILLS ROTARY
TRAFFIC SIGNAL PLAN
(10 OF 10)

SHEET NUMBER
47
OF 53

- FIBER OPTIC INTERCONNECT NOTES:**
1. AT LOCATIONS CALLING FOR PROPOSED FIBER OPTIC CABLE ATTACHMENT TO EXISTING FIBER OPTIC CABLE, CONTRACTOR SHALL COORDINATE ALL WORK WITH THE CITY OF WESTBROOK IT DEPARTMENT. NO WORK SHALL BE CONDUCTED ON THE EXISTING FIBER OPTIC CABLE WITHOUT THE PERMISSION OF THE CITY OF WESTBROOK. CONTRACTOR SHALL NOT CUT NOR DISRUPT IN ANY WAY THE EXISTING FIBER OPTIC CABLE STRANDS THAT ARE NOT USED FOR ATTACHMENT TO THE PROPOSED 12F CABLE.
 2. CONTRACTOR SHALL INSTALL 50 FEET OF FIBER OPTIC CABLE SLACK, MINIMUM, AT EACH CONTROL CABINET.
 3. ALL STRANDS OF THE CABLE SHALL BE TERMINATED ON A FIBER OPTIC PATCH PANEL INSIDE THE CONTROLLER CABINET.
 4. NUMBERS SHOWN ON FIBER OPTIC ARCHITECTURE DIAGRAM INSIDE SPLICE ENCLOSURES AND PATCH PANELS ARE FIBER OPTIC CABLE STRAND NUMBERS. THEY DO NOT REFLECT PATCH PANEL POSITION NUMBERS.
 5. THE CONTRACTOR SHALL NOT CUT NOR DISRUPT IN ANY WAY EXISTING FIBER OPTIC CABLE STRANDS THAT ARE NOT SHOWN IN THESE PLANS.

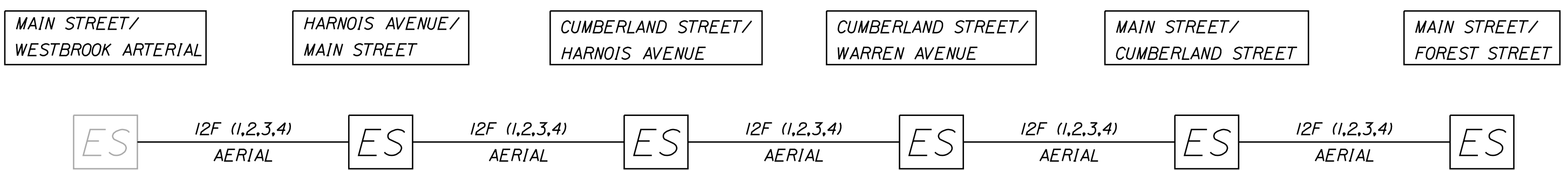
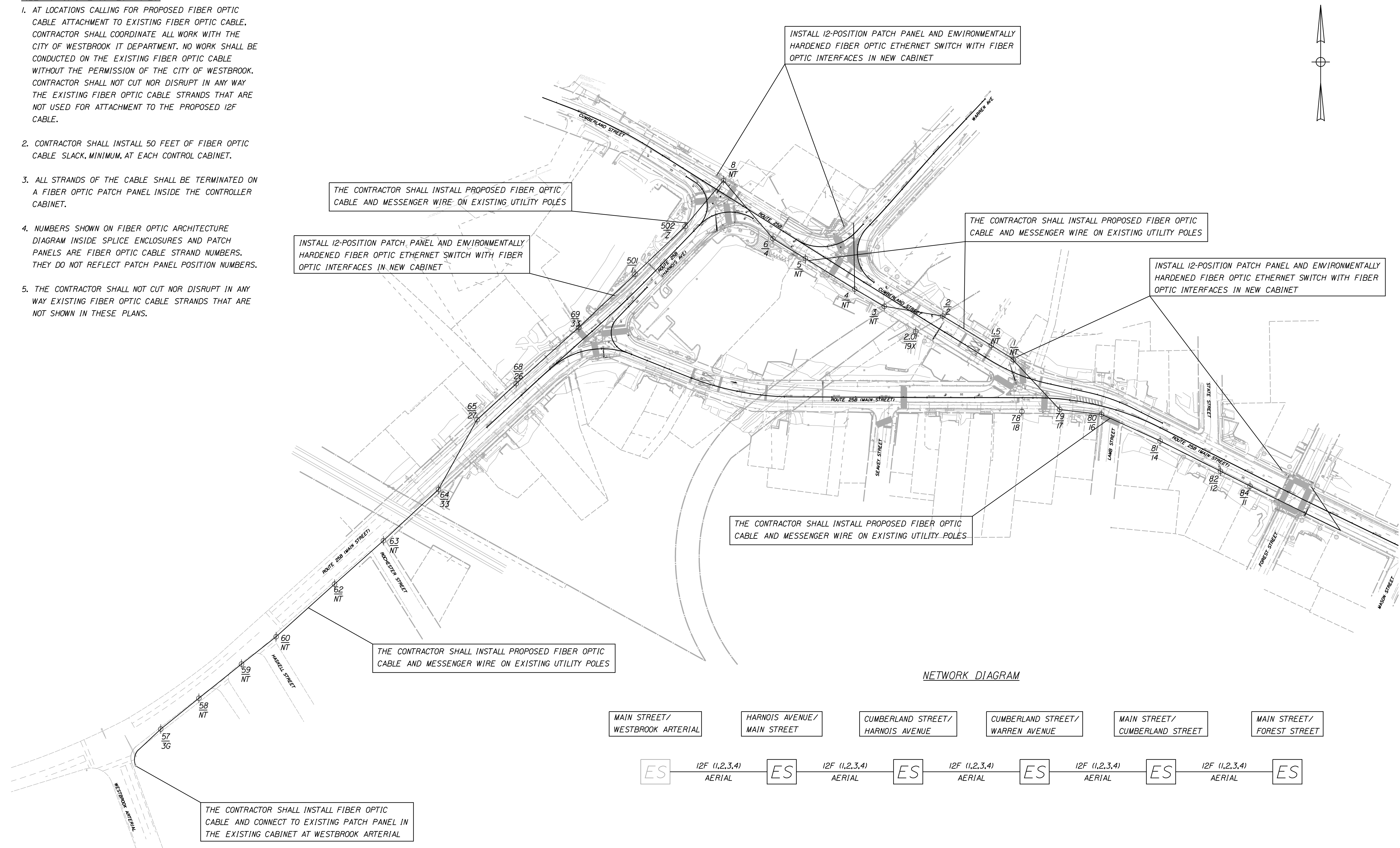

THE CONTRACTOR SHALL INSTALL FIBER OPTIC CABLE AND CONNECT TO EXISTING PATCH PANEL IN THE EXISTING CABINET AT WESTBROOK ARTERIAL

THE CONTRACTOR SHALL INSTALL PROPOSED FIBER OPTIC CABLE AND MESSENGER WIRE ON EXISTING UTILITY POLES

INSTALL 12-POSITION PATCH PANEL AND ENVIRONMENTALLY HARDENED FIBER OPTIC ETHERNET SWITCH WITH FIBER OPTIC INTERFACES IN NEW CABINET

INSTALL 12-POSITION PATCH PANEL AND ENVIRONMENTALLY HARDENED FIBER OPTIC ETHERNET SWITCH WITH FIBER OPTIC INTERFACES IN NEW CABINET

THE CONTRACTOR SHALL INSTALL PROPOSED FIBER OPTIC CABLE AND MESSENGER WIRE ON EXISTING UTILITY POLES

INSTALL 12-POSITION PATCH PANEL AND ENVIRONMENTALLY HARDENED FIBER OPTIC ETHERNET SWITCH WITH FIBER OPTIC INTERFACES IN NEW CABINET

THE CONTRACTOR SHALL INSTALL PROPOSED FIBER OPTIC CABLE AND MESSENGER WIRE ON EXISTING UTILITY POLES

THE CONTRACTOR SHALL INSTALL PROPOSED FIBER OPTIC CABLE AND MESSENGER WIRE ON EXISTING UTILITY POLES

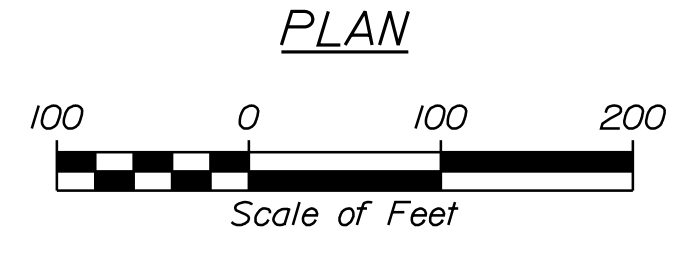

LEGEND

	PROPOSED FIBER OPTIC CABLE
	EXISTING FIBER OPTIC CABLE
	PROPOSED CABINET WITH CONTROLLER
	EXISTING CABINET WITH CONTROLLER



PROJ. MANAGER	B. KEEZER	BY	DATE
DESIGN-DETAILED	MLC	JAR	04/19
CHECKED-REVIEWED	MOS	CMB	04/19
DESIGNS DET AILED			
DESIGNS DET AILED			
REVISIONS 1			
REVISIONS 2			
REVISIONS 3			
REVISIONS 4			
FIELD CHANGES			

**SIGNALIZATION OF
CUMBERLAND MILLS ROTARY
INTERCONNECT PLAN**

MAIN ST / WESTBROOK ARTERIAL

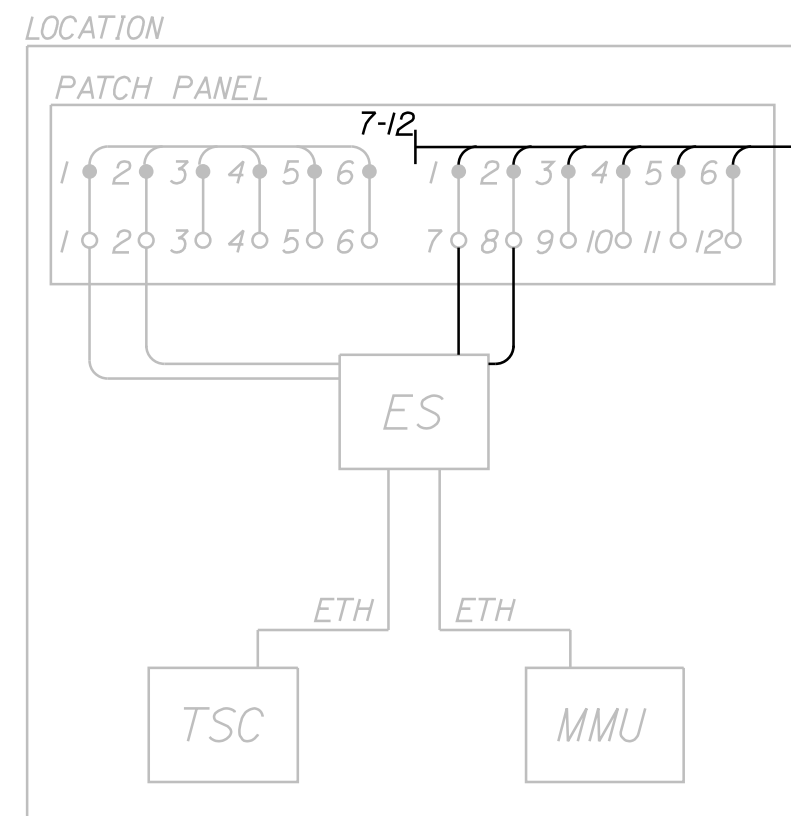

HARNOIS AVE / MAIN ST

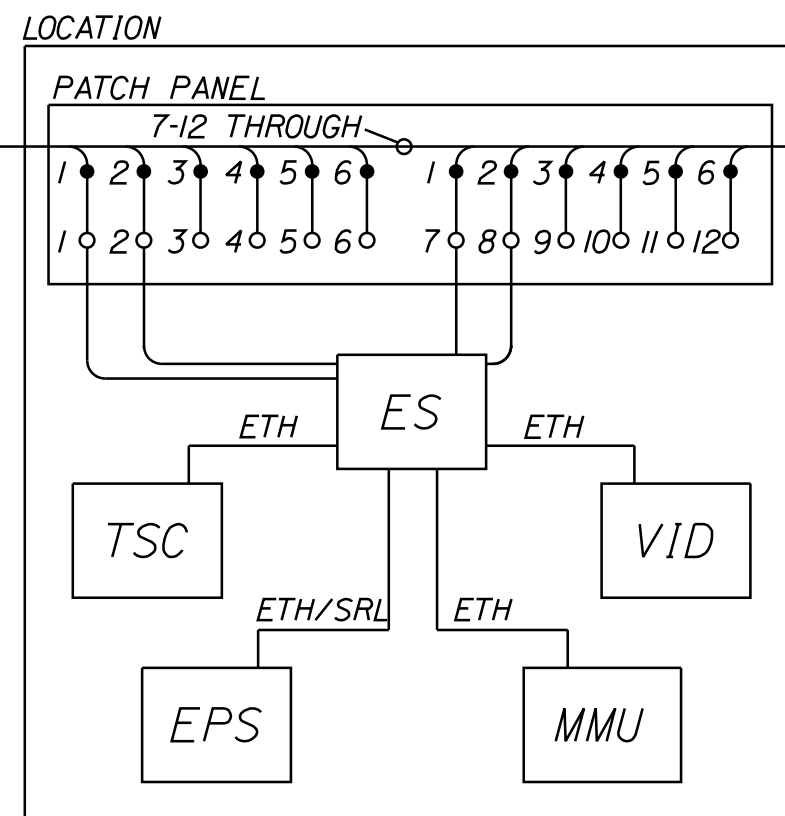

CUMBERLAND ST / HARNOIS AVE

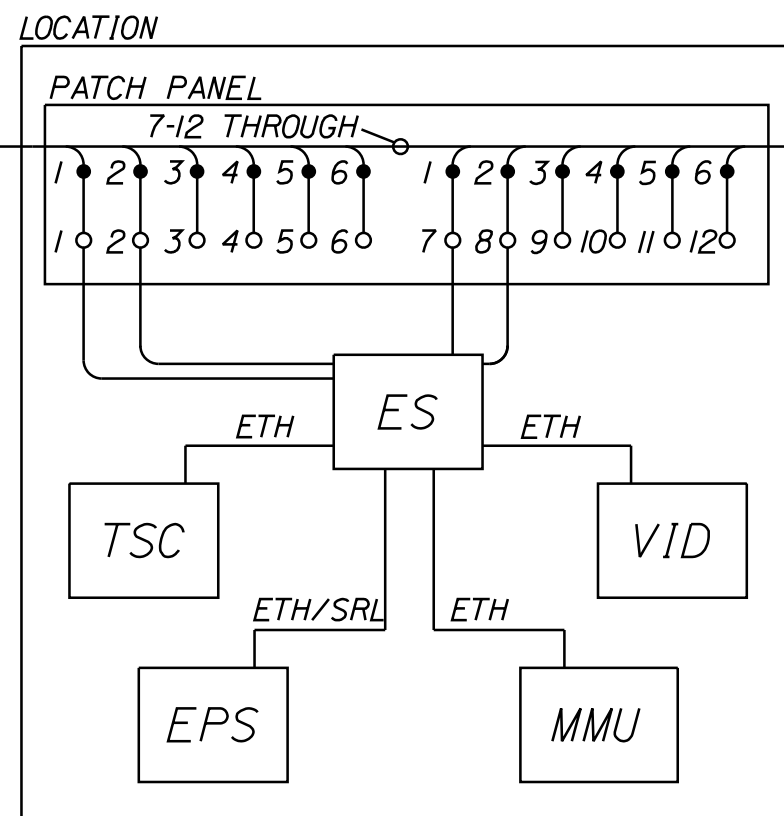

CUMBERLAND ST / WARREN AVE

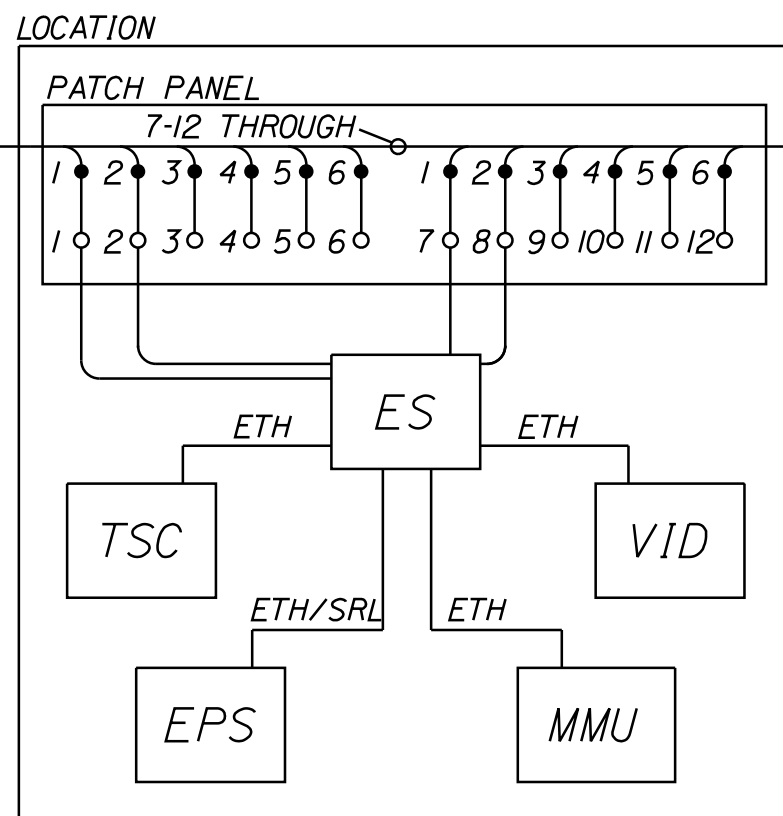

MAIN ST / CUMBERLAND ST

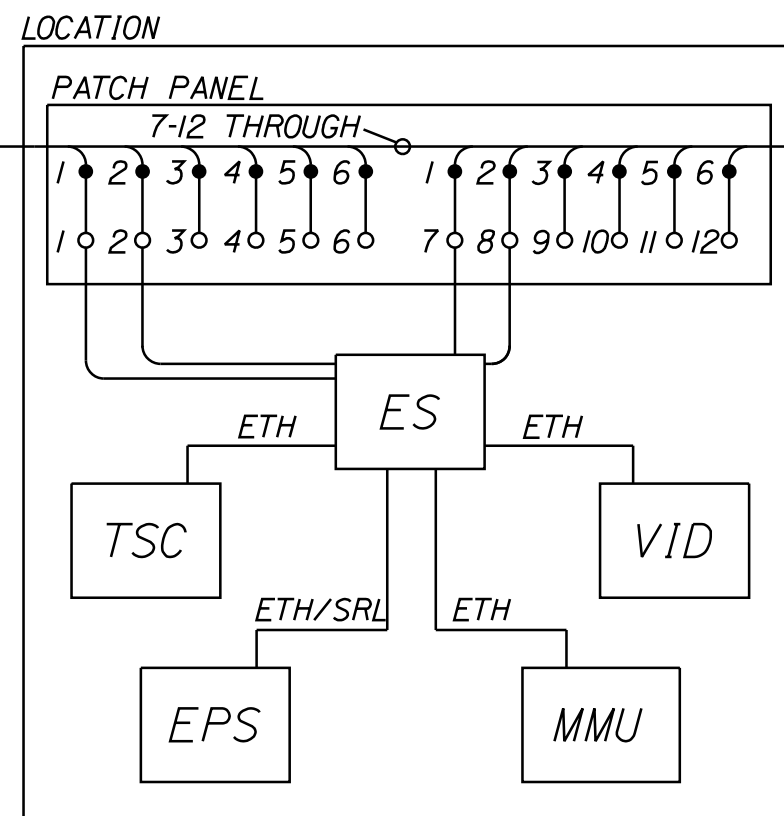

MAIN ST / FOREST ST

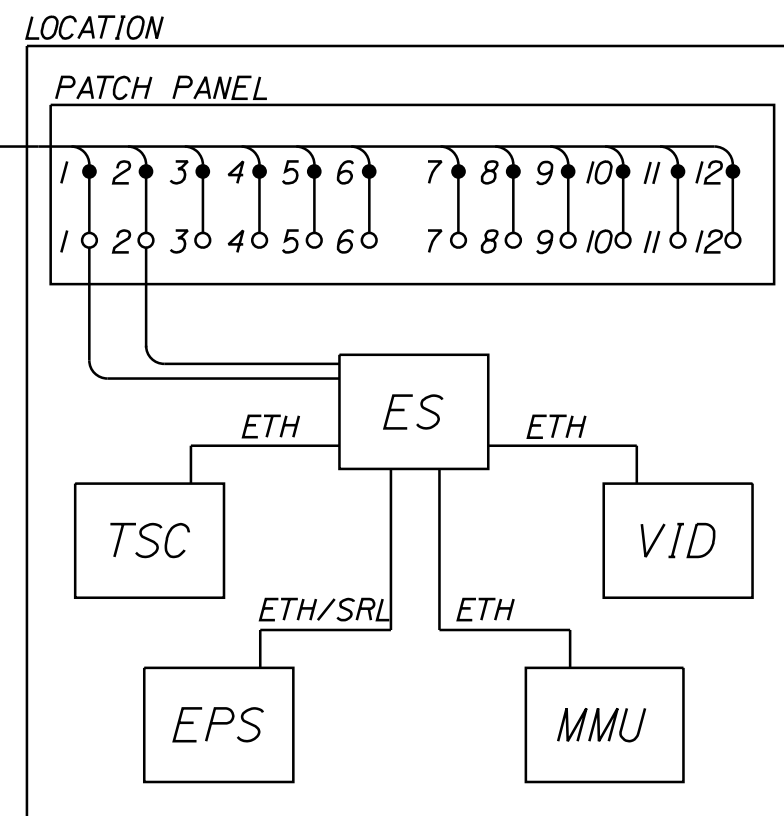

LEGEND

- FIBER OPTIC PIGTAIL
- FIBER OPTIC SPLICE
- ES - FIBER ETHERNET SWITCH
- ETH - ETHERNET CABLE
- ETH/SRL - SERIAL-TO-ETHERNET CONNECTIVITY CABLE (PER MANUFACTURERS RECOMMENDATION)
- EPS - EMERGENCY PREEMPTION SYSTEM
- MMU - MALFUNCTION MANAGEMENT UNIT
- PP - PATCH PANEL
- SE - SPLICE ENCLOSURE
- TSC - TRAFFIC SIGNAL CONTROLLER
- VID - VIDEO DETECTION CONTROL UNIT
- EXISTING EQUIPMENT



PROJ. MANAGER	B. KEEZER	BY	DATE
DESIGN-DETAILED	MJC	JAR	04/19
CHECKED-REVIEWED	MOS	CMB	04/19
DESIGN-DETAILED			
DESIGN-DETAILED			
REVISIONS 1			
REVISIONS 2			
REVISIONS 3			
REVISIONS 4			
FIELD CHANGES			

**SIGNALIZATION OF
CUMBERLAND MILLS ROTARY
SYSTEM ARCHITECTURE
DIAGRAM**

SHEET NUMBER

49

OF 53

**MAIN ST AT WESTBROOK ARTERIAL
FIBER OPTIC SPLICE TABLE**

	CABLE	STRAND	CONNECTION TYPE	CABLE	STRAND	DESCRIPTION
PATCH PANEL AT CONTROLLER CABINET (MAIN ST / WESTBROOK ARTERIAL)	12F (EXISTING) FROM CABINET	1	SPLICE	12F (EXISTING)	-	ACTIVE STRAND
	12F (EXISTING) FROM CABINET	2	SPLICE	12F (EXISTING)	-	ACTIVE STRAND
	12F (EXISTING) FROM CABINET	3	SPLICE	PIGTAIL	-	SPARE, PP POSITION 3
	12F (EXISTING) FROM CABINET	4	SPLICE	PIGTAIL	-	SPARE, PP POSITION 4
	12F (EXISTING) FROM CABINET	5	SPLICE	PIGTAIL	-	SPARE, PP POSITION 5
	12F (EXISTING) FROM CABINET	6	SPLICE	PIGTAIL	-	SPARE, PP POSITION 6
	12F (EXISTING) FROM CABINET	7-12	SPLICE	PIGTAIL	-	-
	12F TO MAIN ST	1	SPLICE	PIGTAIL	-	ES, PP POSITION 7
	12F TO MAIN ST	2	SPLICE	PIGTAIL	-	ES, PP POSITION 8
	12F TO MAIN ST	3	SPLICE	PIGTAIL	-	SPARE, PP POSITION 9
	12F TO MAIN ST	4	SPLICE	PIGTAIL	-	SPARE, PP POSITION 10
	12F TO MAIN ST	5	SPLICE	PIGTAIL	-	SPARE, PP POSITION 11
	12F TO MAIN ST	6	SPLICE	PIGTAIL	-	SPARE, PP POSITION 12

**HARNOIS AVE AT MAIN ST
FIBER OPTIC SPLICE TABLE**

	CABLE	STRAND	CONNECTION TYPE	CABLE	STRAND	DESCRIPTION
PATCH PANEL AT CONTROLLER CABINET (HARNOIS AVE / MAIN ST)	12F FROM WESTBROOK ARTERIAL	1	SPLICE	PIGTAIL	-	ES, PP POSITION 1
	12F FROM WESTBROOK ARTERIAL	2	SPLICE	PIGTAIL	-	ES, PP POSITION 2
	12F FROM WESTBROOK ARTERIAL	3	SPLICE	PIGTAIL	-	SPARE, PP POSITION 3
	12F FROM WESTBROOK ARTERIAL	4	SPLICE	PIGTAIL	-	SPARE, PP POSITION 4
	12F FROM WESTBROOK ARTERIAL	5	SPLICE	PIGTAIL	-	SPARE, PP POSITION 5
	12F FROM WESTBROOK ARTERIAL	6	SPLICE	PIGTAIL	-	SPARE, PP POSITION 6
	12F FROM WESTBROOK ARTERIAL	7-12	THROUGH	12 F TO CUMBERLAND ST/HARNOIS AVE	-	-
	12F TO CUMBERLAND ST/HARNOIS AVE	1	SPLICE	PIGTAIL	-	ES, PP POSITION 1
	12F TO CUMBERLAND ST/HARNOIS AVE	2	SPLICE	PIGTAIL	-	ES, PP POSITION 2
	12F TO CUMBERLAND ST/HARNOIS AVE	3	SPLICE	PIGTAIL	-	SPARE, PP POSITION 3
	12F TO CUMBERLAND ST/HARNOIS AVE	4	SPLICE	PIGTAIL	-	SPARE, PP POSITION 4
	12F TO CUMBERLAND ST/HARNOIS AVE	5	SPLICE	PIGTAIL	-	SPARE, PP POSITION 5
	12F TO CUMBERLAND ST/HARNOIS AVE	6	SPLICE	PIGTAIL	-	SPARE, PP POSITION 6

**CUMBERLAND ST AT HARNOIS AVE
FIBER OPTIC SPLICE TABLE**

	CABLE	STRAND	CONNECTION TYPE	CABLE	STRAND	DESCRIPTION
PATCH PANEL AT CONTROLLER CABINET (CUMBERLAND ST / HARNOIS AVE)	12F FROM HARNOIS AVE/ MAIN ST	1	SPLICE	PIGTAIL	-	ES, PP POSITION 1
	12F FROM HARNOIS AVE/ MAIN ST	2	SPLICE	PIGTAIL	-	ES, PP POSITION 2
	12F FROM HARNOIS AVE/ MAIN ST	3	SPLICE	PIGTAIL	-	SPARE, PP POSITION 3
	12F FROM HARNOIS AVE/ MAIN ST	4	SPLICE	PIGTAIL	-	SPARE, PP POSITION 4
	12F FROM HARNOIS AVE/ MAIN ST	5	SPLICE	PIGTAIL	-	SPARE, PP POSITION 5
	12F FROM HARNOIS AVE/ MAIN ST	6	SPLICE	PIGTAIL	-	SPARE, PP POSITION 6
	12F FROM HARNOIS AVE/ MAIN ST	7-12	THROUGH	12 F TO WARREN AVE	-	-
	12F TO WARREN AVE	1	SPLICE	PIGTAIL	-	ES, PP POSITION 1
	12F TO WARREN AVE	2	SPLICE	PIGTAIL	-	ES, PP POSITION 2
	12F TO WARREN AVE	3	SPLICE	PIGTAIL	-	SPARE, PP POSITION 3
	12F TO WARREN AVE	4	SPLICE	PIGTAIL	-	SPARE, PP POSITION 4
	12F TO WARREN AVE	5	SPLICE	PIGTAIL	-	SPARE, PP POSITION 5
	12F TO WARREN AVE	6	SPLICE	PIGTAIL	-	SPARE, PP POSITION 6

**CUMBERLAND ST AT WARREN AVE
FIBER OPTIC SPLICE TABLE**

	CABLE	STRAND	CONNECTION TYPE	CABLE	STRAND	DESCRIPTION
PATCH PANEL AT CONTROLLER CABINET (CUMBERLAND ST / WARREN AVE)	12F FROM CUMBERLAND ST /HARNOIS AVE	1	SPLICE	PIGTAIL	-	ES, PP POSITION 1
	12F FROM CUMBERLAND ST /HARNOIS AVE	2	SPLICE	PIGTAIL	-	ES, PP POSITION 2
	12F FROM CUMBERLAND ST /HARNOIS AVE	3	SPLICE	PIGTAIL	-	SPARE, PP POSITION 3
	12F FROM CUMBERLAND ST /HARNOIS AVE	4	SPLICE	PIGTAIL	-	SPARE, PP POSITION 4
	12F FROM CUMBERLAND ST /HARNOIS AVE	5	SPLICE	PIGTAIL	-	SPARE, PP POSITION 5
	12F FROM CUMBERLAND ST /HARNOIS AVE	6	SPLICE	PIGTAIL	-	SPARE, PP POSITION 6
	12F FROM CUMBERLAND ST /HARNOIS AVE	7-12	THROUGH	12 F TO MAIN ST/CUMBERLAND ST	-	-
	12F TO MAIN ST/ CUMBERLAND ST	1	SPLICE	PIGTAIL	-	ES, PP POSITION 1
	12F TO MAIN ST/ CUMBERLAND ST	2	SPLICE	PIGTAIL	-	ES, PP POSITION 2
	12F TO MAIN ST/ CUMBERLAND ST	3	SPLICE	PIGTAIL	-	SPARE, PP POSITION 3
	12F TO MAIN ST/ CUMBERLAND ST	4	SPLICE	PIGTAIL	-	SPARE, PP POSITION 4
	12F TO MAIN ST/ CUMBERLAND ST	5	SPLICE	PIGTAIL	-	SPARE, PP POSITION 5
	12F TO MAIN ST/ CUMBERLAND ST	6	SPLICE	PIGTAIL	-	SPARE, PP POSITION 6

**MAIN ST AT CUMBERLAND ST
FIBER OPTIC SPLICE TABLE**

	CABLE	STRAND	CONNECTION TYPE	CABLE	STRAND	DESCRIPTION
PATCH PANEL AT CONTROLLER CABINET (MAIN ST / CUMBERLAND ST)	12F FROM WARREN AVE	1	SPLICE	PIGTAIL	-	ES, PP POSITION 1
	12F FROM WARREN AVE	2	SPLICE	PIGTAIL	-	ES, PP POSITION 2
	12F FROM WARREN AVE	3	SPLICE	PIGTAIL	-	SPARE, PP POSITION 3
	12F FROM WARREN AVE	4	SPLICE	PIGTAIL	-	SPARE, PP POSITION 4
	12F FROM WARREN AVE	5	SPLICE	PIGTAIL	-	SPARE, PP POSITION 5
	12F FROM WARREN AVE	6	SPLICE	PIGTAIL	-	SPARE, PP POSITION 6
	12F FROM WARREN AVE	7-12	THROUGH	12 F TO FOREST ST	-	-
	12F TO FOREST ST	1	SPLICE	PIGTAIL	-	ES, PP POSITION 1
	12F TO FOREST ST	2	SPLICE	PIGTAIL	-	ES, PP POSITION 2
	12F TO FOREST ST	3	SPLICE	PIGTAIL	-	SPARE, PP POSITION 3
	12F TO FOREST ST	4	SPLICE	PIGTAIL	-	SPARE, PP POSITION 4
	12F TO FOREST ST	5	SPLICE	PIGTAIL	-	SPARE, PP POSITION 5
	12F TO FOREST ST	6	SPLICE	PIGTAIL	-	SPARE, PP POSITION 6

**MAIN ST AT FOREST ST
FIBER OPTIC SPLICE TABLE**

	CABLE	STRAND	CONNECTION TYPE	CABLE	STRAND	DESCRIPTION
PATCH PANEL AT CONTROLLER CABINET (MAIN ST / FOREST ST)	12F FROM MAIN ST /CUMBERLAND ST	1	SPLICE	PIGTAIL	-	ES, PP POSITION 1
	12F FROM MAIN ST /CUMBERLAND ST	2	SPLICE	PIGTAIL	-	ES, PP POSITION 2
	12F FROM MAIN ST /CUMBERLAND ST	3	SPLICE	PIGTAIL	-	SPARE, PP POSITION 3
	12F FROM MAIN ST /CUMBERLAND ST	4	SPLICE	PIGTAIL	-	SPARE, PP POSITION 4
	12F FROM MAIN ST /CUMBERLAND ST	5	SPLICE	PIGTAIL	-	SPARE, PP POSITION 5
	12F FROM MAIN ST /CUMBERLAND ST	6	SPLICE	PIGTAIL	-	SPARE, PP POSITION 6
	12F FROM MAIN ST /CUMBERLAND ST	7	SPLICE	PIGTAIL	-	SPARE, PP POSITION 7
	12F FROM MAIN ST /CUMBERLAND ST	8	SPLICE	PIGTAIL	-	SPARE, PP POSITION 8
	12F FROM MAIN ST /CUMBERLAND ST	9	SPLICE	PIGTAIL	-	SPARE, PP POSITION 9
	12F FROM MAIN ST /CUMBERLAND ST	10	SPLICE	PIGTAIL	-	SPARE, PP POSITION 10
	12F FROM MAIN ST /CUMBERLAND ST	11	SPLICE	PIGTAIL	-	SPARE, PP POSITION 11
	12F FROM MAIN ST /CUMBERLAND ST	12	SPLICE	PIGTAIL	-	SPARE, PP POSITION 12

NOTES:

- ALL FIBER OPTIC PIGTAILS SHALL BE TERMINATED ON PATCH PANELS.
- FIBER OPTIC CABLE BENDS SHALL EXCEED THE MINIMUM BENDING RADIUS FOR THE CABLE AT ALL TIMES DURING THE INSTALLATION, MODIFICATION, REPAIR, SPLICING OR IN THE PERMANENT CONDITION.
- FIBER OPTIC CABLE SHALL NOT BE SPLICED EXCEPT AS SHOWN ON THE PLANS. FIBERS NOT TERMINATED IN A SPLICE ENCLOSURE, PATCH PANEL, OR SHOWN AS THROUGH FIBERS SHALL NOT BE CUT.

LEGEND	
	FIBER OPTIC PIGTAIL
	FIBER OPTIC SPLICE
ES -	FIBER ETHERNET SWITCH
ETH -	ETHERNET CABLE
ETH/SRL -	SERIAL-TO-ETHERNET CONNECTIVITY CABLE (PER MANUFACTURERS RECOMMENDATION)
EPS -	EMERGENCY PREEMPTION SYSTEM
MMU -	MALFUNCTION MANAGEMENT UNIT
PP -	PATCH PANEL
SE -	SPLICE ENCLOSURE
TSC -	TRAFFIC SIGNAL CONTROLLER
VID -	VIDEO DETECTION CONTROL UNIT
	EXISTING EQUIPMENT



PLAN LEGEND

Existing	Proposed	Existing	Proposed
Sanitary Sewer	Telephone Line	Traveled Way	Ditch
Electric Line	Water Line	Catch Basin	Manhole
Underdrain Line	Gas Line	Sewer Manhole	Utility Pole
Guardrail	Culvert	Fire Hydrant	Curbing

STATE OF MAINE
REGISTRY OF DEEDS

COUNTY RECEIVED _____
at _____ h _____ m _____ M and recorded in _____
Plan Book _____, Page _____
Attest: _____ REGISTER

THIS PLAN WAS PREPARED IN CONNECTION WITH THE DEPARTMENT'S ACQUISITION OF REAL PROPERTY FOR TRANSPORTATION PURPOSES. IT CANNOT BE USED TO ESTABLISH LEGAL BOUNDARIES BETWEEN ADJACENT PROPERTY OWNERS.

Scale of Feet: 0, 25, 50, 75, 100

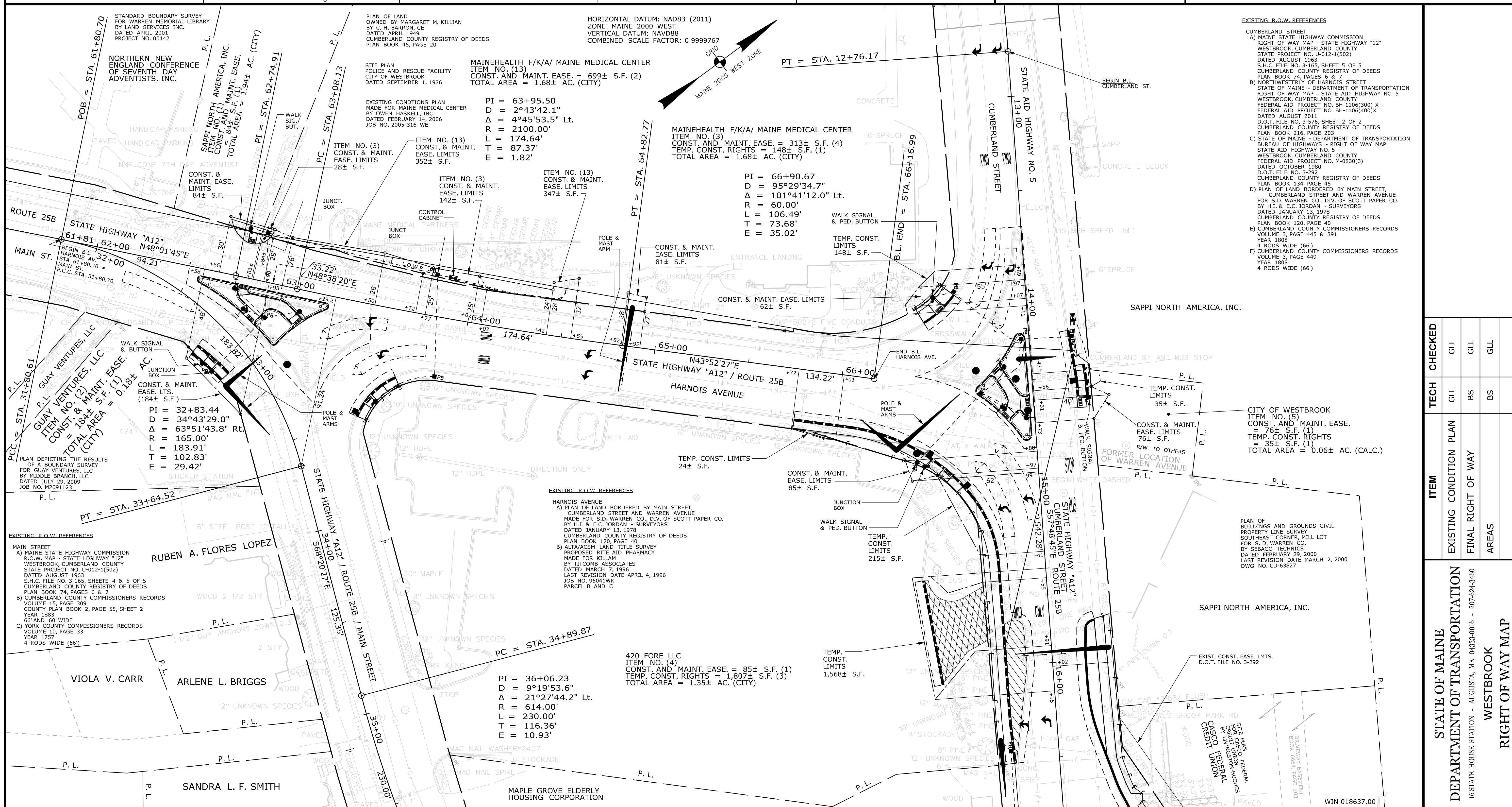

Date: 2/13/2020
Username: Guy.Ladd
Division: ROW
Filename: ... \001\ROW\MSTA051_RWP\LANI.dgn

ITEM	TECH	CHECKED
EXISTING CONDITION PLAN	BS	BS
FINAL RIGHT OF WAY	BS	BS
AREAS	BS	BS

STATE OF MAINE
DEPARTMENT OF TRANSPORTATION
16 STATE HOUSE STATION - AUGUSTA, ME 04333-0016 - 207-624-3460
WESTBROOK
RIGHT OF WAY MAP

REVISIONS			PLAN FILED IN PLAN BOOK				PAGE			COUNTY RECORD		
NO.	DATE	DESCRIPTION	BY	NO.	GRANTOR	INSTRUMENT	DATE	BOOK	PAGE			
1	5/2019	ADDED NEW CONST. & MAINT. EASE. FOR NEW ITEM (13)	B.S.	13	MAINEHEALTH f/k/a MAINE MEDICAL CENTER	COND. C.M.E.	4/29/19	35605	159			
							6/17/19	35903	231			

BRUCE A. VAN NOTE
COMMISSIONER
JOYCE NOEL TAYLOR
CHIEF ENGINEER
DATE

STATE HWY. "A12" & STATE AID HWY. NO. 5
CUMBERLAND ST. / MAIN ST. / HARNOIS AVE.
WESTBROOK CUMBERLAND COUNTY
FEDERAL AID PROJECT NO. STP-1863(700)

JUNE 2018
SCALE 1" = 25'

RIGHT-OF-WAY MAP
SHEET 1 OF 3

D.O.T. FILE NO. 3-629

SHEET NUMBER
51
OF 53

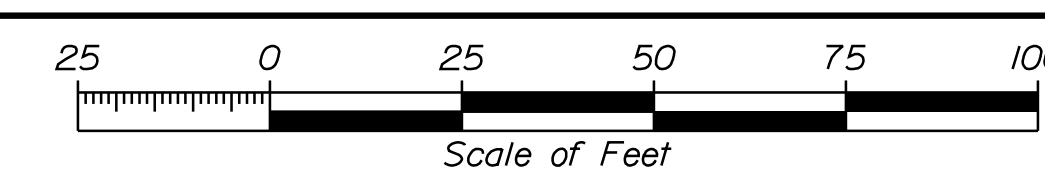
Town, County, State _____ Approx. Property Lines _____ P.L. Existing Right of Way _____ Limits of Wrought Portion _____ L.O.W.P. Control Of Access _____ C.O.A. New Right of Way _____ New Easement _____ New Temporary Rights _____ New R/W Within Existing R/W _____	PLAN LEGEND <table border="0" style="width:100%;"> <tr> <td>Existing</td><td>Proposed</td></tr> <tr> <td>Sanitary Sewer</td><td>Telephone Line</td></tr> <tr> <td>Electric Line</td><td>Traveled Way</td></tr> <tr> <td>Water Line</td><td>Ditch</td></tr> <tr> <td>Underdrain Line</td><td>Catch Basin</td></tr> <tr> <td>Gas Line</td><td>Manhole</td></tr> <tr> <td>Guardrail</td><td>Sewer Manhole</td></tr> <tr> <td>Culvert</td><td>Utility Pole</td></tr> <tr> <td></td><td>Fire Hydrant</td></tr> <tr> <td></td><td>Curbing</td></tr> </table>	Existing	Proposed	Sanitary Sewer	Telephone Line	Electric Line	Traveled Way	Water Line	Ditch	Underdrain Line	Catch Basin	Gas Line	Manhole	Guardrail	Sewer Manhole	Culvert	Utility Pole		Fire Hydrant		Curbing	STATE OF MAINE REGISTRY OF DEEDS COUNTY _____ RECEIVED _____ at _____ h _____ m _____ M and recorded in Plan Book _____, Page _____ Attest: _____ REGISTER	THIS PLAN WAS PREPARED IN CONNECTION WITH THE DEPARTMENT'S ACQUISITION OF REAL PROPERTY FOR TRANSPORTATION PURPOSES. IT CANNOT BE USED TO ESTABLISH LEGAL BOUNDARIES BETWEEN ABUTTING PROPERTY OWNERS. 
Existing	Proposed																						
Sanitary Sewer	Telephone Line																						
Electric Line	Traveled Way																						
Water Line	Ditch																						
Underdrain Line	Catch Basin																						
Gas Line	Manhole																						
Guardrail	Sewer Manhole																						
Culvert	Utility Pole																						
	Fire Hydrant																						
	Curbing																						

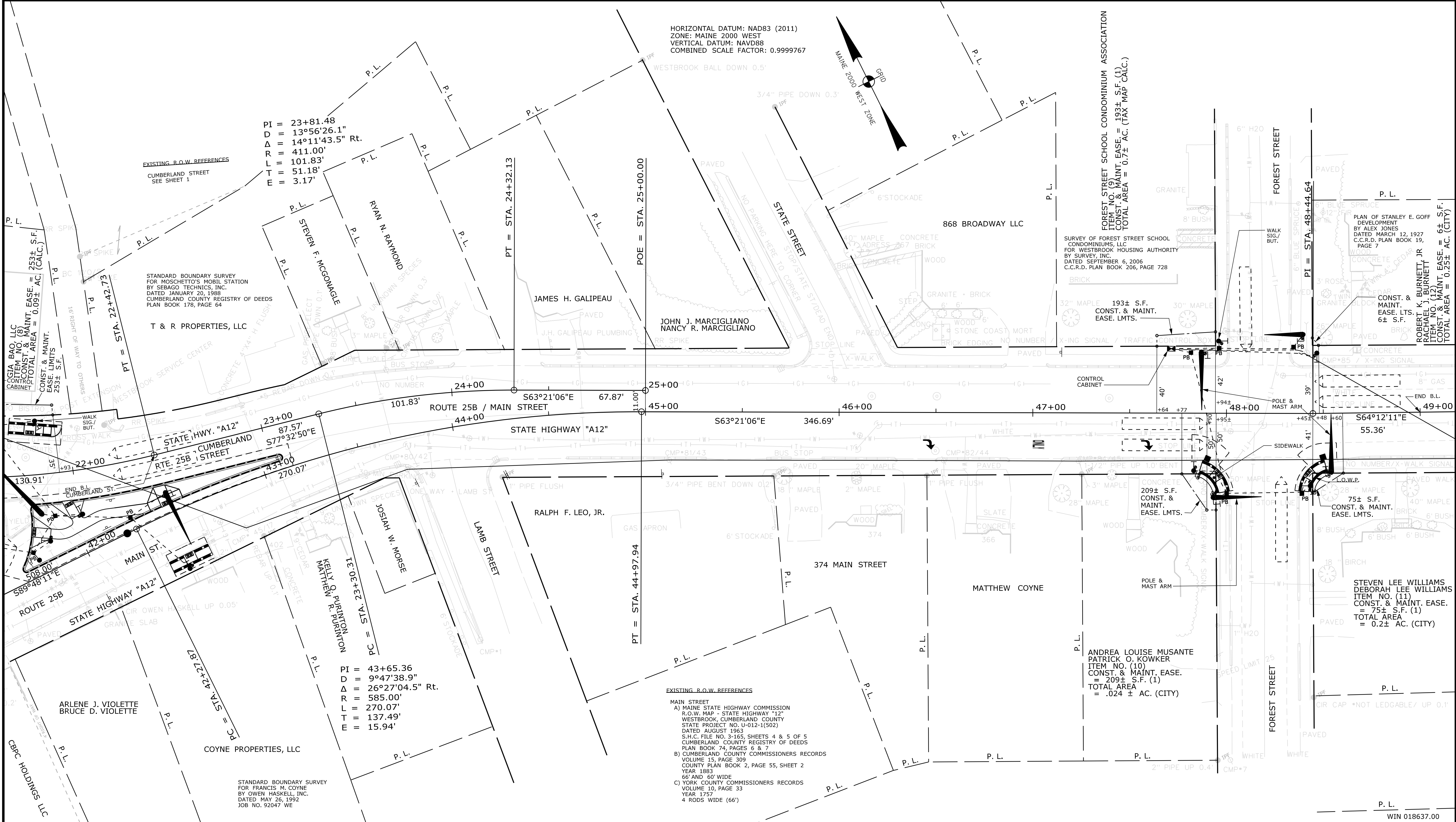

	TECH	CHECKED		
EXISTING CONDITION PLAN	G.L.L.	G.L.L.	G.L.L.	G.L.L.
FINAL RIGHT OF WAY AREAS	BS	BS	BS	BS
STATE OF MAINE DEPARTMENT OF TRANSPORTATION 16 STATE HOUSE STATION - AUGUSTA, ME 04333-0016 - 207-624-3460	STATE OF MAINE DEPARTMENT OF TRANSPORTATION WESTBROOK RIGHT OF WAY MAP	SHEET NUMBER	53	
		JUNE 2018 SCALE 1" = 25'	RIGHT-OF-WAY MAP SHEET 3 OF 3	D.O.T. FILE NO. 3-629 OF 53

REVISIONS			PLAN FILED IN PLAN BOOK				PAGE COUNTY RECORD				BRUCE A. VAN NOTE COMMISSIONER JOYCE NOEL TAYLOR CHIEF ENGINEER DATE		
NO.	DATE	DESCRIPTION	NO.	GRANTOR	INSTRUMENT	DATE	BOOK	PAGE	COND.	4/29/19		35605	159

Filename: ... \00\ROW\WSTA053_RWPLAN3.dgn
 Division: ROW
 Username: Guy.Lodd
 Date: 2/13/2020