



STATE OF MAINE
DEPARTMENT OF TRANSPORTATION
16 STATE HOUSE STATION
AUGUSTA, MAINE 04333-0016

Janet T. Mills
GOVERNOR

Dale F. Doughty
COMMISSIONER

February 11, 2026
Subject: Crew Quarters
WIN: 028559.00
Location: Waldoboro
Amendment No. 2

Dear Sir/Ms.:

The following questions have been received:

Question: The gear for these buildings state 65AIC Rated on panels, is it fully rated or series rated? There is a large cost difference between the two

Response: The panels are series rated.

Question: Does this project require compliance with BABBAA?

Response: BABBAA is not required for this project.

Question: They are asking for Maple Veneer clear finish. Is prefinished maple acceptable with them?

Response: Shop finishing is to be provided. See specification section 064023-Section 2.10 for additional information.

Question: Is there an HHE-200 available for the septic design

Response: The HHE-200 is included in the Contract Bid Book

Question: We do not have Type 1 L cement as mentioned in the specifications. We utilize Type 1-2 cement, is this acceptable?

Response: Please provide Type 1 L cement for the project.

Question: Is it acceptable to use Densepack Cellulose in the Roof and the Exterior Walls instead of Densepack Cellulose in the Roof System and Densepack Timber HP in the Exterior Walls?

Response: Yes. Provide Cellulose Blown-In Insulation at the exterior wall and roof locations as specified. Delete specifications sections 072100 Item 2.1 and 2.2 in reference to Wood Fiber insulation.

Question: Are we quoting Sound Batts in any or all of the Interior Partitions?

Response: Please provide sound batt insulation on all interior walls of all toilet rooms, shower, offices and training room. Sound batt insulation to be equal to Owens Corning, Unfaced Sound Attenuation Batts, Type 1 ASTM C 665. Insulation to fill depth and width of framing bays.

Question: Per Everlast the 20-year weathertight warranty is not available for the NS-100 panel as specified, it's only offered on the DL-150 mechanical seamed panel

Response: Please see communications with Everlast Metals below. Contractor to include warranty pricing and warranty with roofing bid.

We can provide a 20-year WTW for the NS 100 line.

We outsource this to a company that will come out and inspect the work progress and finish. This is done both virtually for the progress and in person for the final.

To get pricing, we need a drawing of the project and the product specifications.

Please feel free to call or email if you would like to discuss in more detail.

We look forward to working with you and your client.

Thank you



Question: I am looking for details regarding the propane tanks for Waldoboro & Eddington, are they buried or above ground? If they are above ground is there a detail for the pad it sits on? Also, is there a detail for the generator pads?

Response: All crew quarters projects propane tanks are to be placed above ground. Please see slab details for both propane and generator slabs for all locations. Please see drawing ASK-2

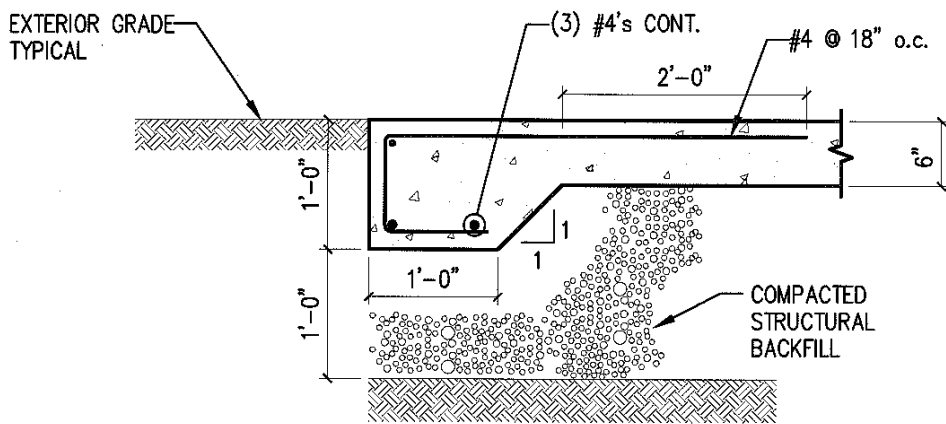

NOTES:

1. CONCRETE PAD TO BE 12 INCHES LARGER THAN THE EXTERIOR DIMENSIONS OF THE PROPANE TANKS.
2. TOP SURFACE OF THE CONCRETE PAD TO BE BROOM FINISHED.
3. CONCRETE PAD EDGES TO HAVE A TOOLED UNIFORM RADIUS.
4. PROVIDE 4,500 PSI CONCRETE FOR EXTERIOR CONCRETE PAD.

TYPICAL CONCRETE PAD DETAIL

MDOT CREW QUARTERS

PROPANE SLAB DETAIL

CLIENT:
MAINE DOT
AUGUSTA, MAINE

TRILLIUM
ENGINEERING GROUP
251 US ROUTE ONE SUITE 0-2
FALMOUTH, ME 04105

SCALE:	3/4"=1'-0"
DESIGNED:	ED
DRAWN:	ED
DATE:	02-09-20
PROJECT NUMBER:	25-033

ASK-02

Question: Specification 271500-1.8-A states the communication cabling shall be installed by a BICSI certified technician. Is it acceptable to have a non-BICSI certified technician install the communication cabling for these projects?

Response: The Office of Information and Technology (OIT) and their authorized contractors will be doing all installs for all communications/data cabling and any related panels/ hardware for such. The winning contractor(s) is responsible only for installing the conduits, and associated pull strings shown in the plan sets for such lines.

Consider these changes and information prior to submitting your bid on **February 18, 2026.**

Sincerely,



George M. A. Macdougall P.E.
Contracts & Specifications Engineer