



STATE OF MAINE
DEPARTMENT OF TRANSPORTATION
16 STATE HOUSE STATION
AUGUSTA, MAINE 04333-0016

Janet T. Mills
GOVERNOR

Bruce A. Van Note
COMMISSIONER

April 8, 2022
Subject: HMA Overlay with Drainage
Improvements
State WINs: 024991.00 & 024993.00
Location: **Scarborough**
Amendment No. 2

Dear Sir/Ms.:

Make the following changes to the Bid Documents:

In the Bid Book:

ADD the attached "SELFLEVEL Assembly" Detail, 1 page.

The following questions have been received:

Question: Please supply more information/shop drawings for the 10 self leveling sewer manhole covers.

Response: See attached "SELFLEVEL Assembly" Detail.

Question: How does the installation of these differ from the standard manhole frames/covers?

Response: See attached "SELFLEVEL Assembly" Detail.

Consider these changes and information prior to submitting your bid on **April 13, 2022**.

Sincerely,

A handwritten signature in blue ink that reads "George Macdougall".

George M. A. Macdougall P.E.
Contracts & Specifications Engineer

SELFLEVEL Assembly

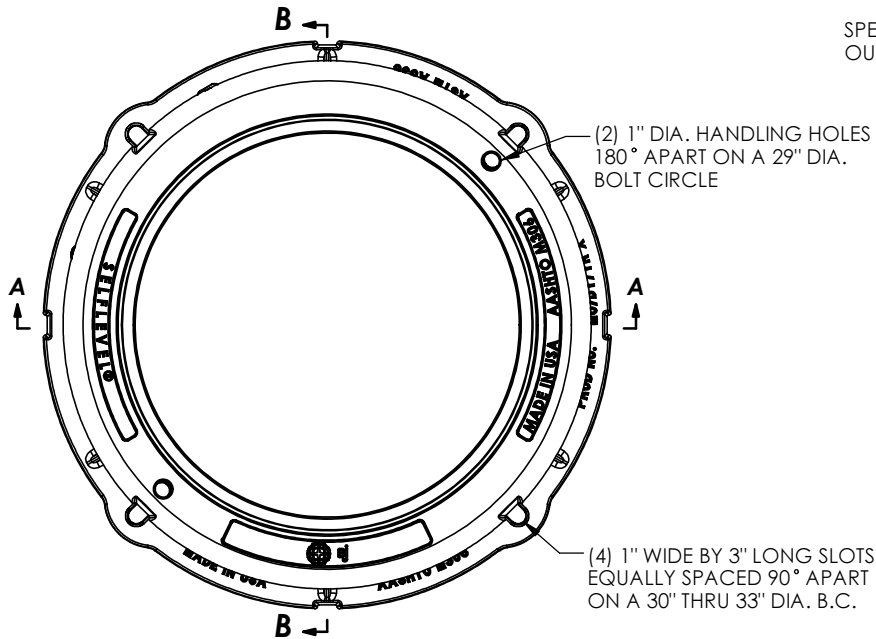

SPECIAL GASKET FOR KEEPING
OUT DEBRIS & STILL ALLOWING
FULL RANGE OF MOTION

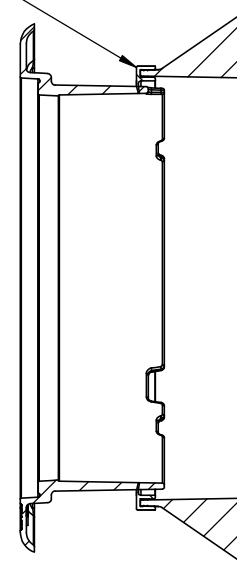

SECTION B-B

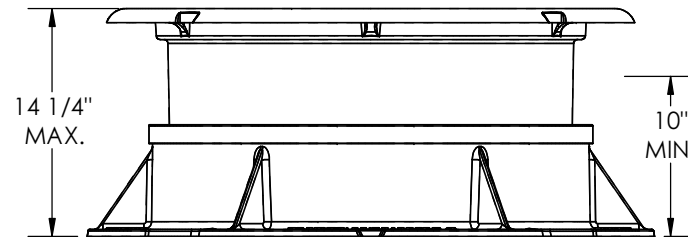
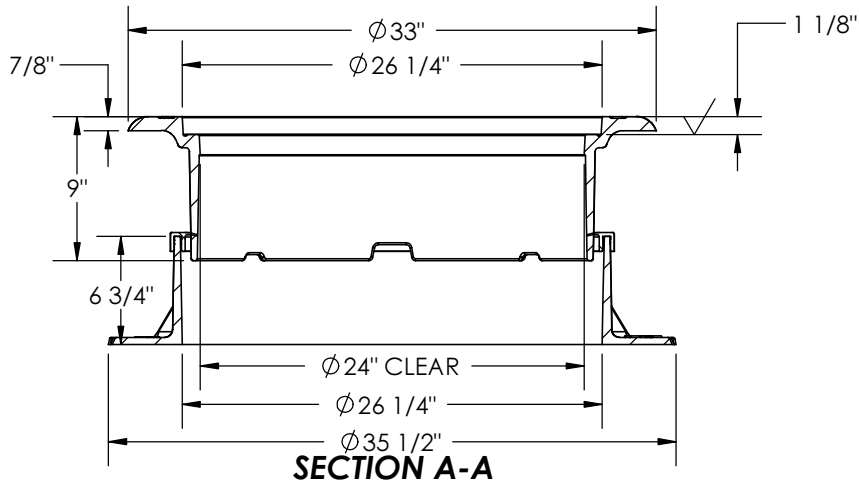

**SIDE VIEW
(SHOWING TRAVEL OF UPPER FRAME)**

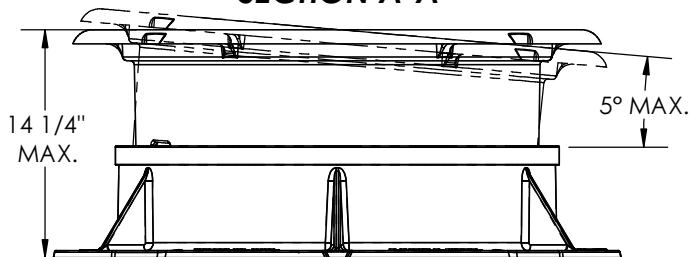

**FRONT VIEW
(SHOWING MAXIMUM TIP @ 5° ANGLE)**

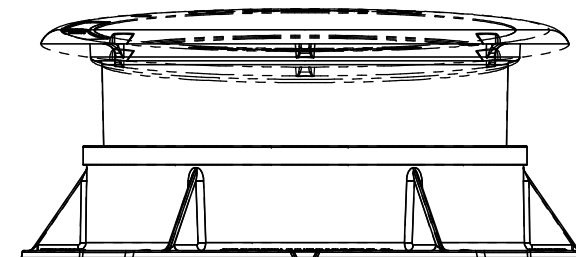

**SIDE VIEW
(SHOWING MAXIMUM TIP @ 5° ANGLE)**

Product Number

00302429A01

Design Features

- Materials
- Frame Ductile Iron (80-55-06)
- Frame Ductile Iron (80-55-06)

- Design Load Heavy Duty
- Open Area n/a
- Coating Undipped
- √ Designates Machined Surface

Certification

- ASTM A536
-
- Country of Origin: USA

Major Components

- 00302429
- 00302417

Drawing Revision

- 5/21/2008 Designer: SBB
- 3/8/2019 Revised By: DAE

Disclaimer

Weights (lbs/kg), dimensions (inches/mm) and drawings provided for your guidance. We reserve the right to modify specifications without prior notice.

CONFIDENTIAL: This drawing is the property of EJ Group, Inc. and embodies confidential information, registered marks, patents, trade secret information, and/or know-how that is the property of EJ Group, Inc. Copyright © 2011 EJ Group, Inc. All rights reserved.

Contact

800.626.4653
ejco.com