

ON CALL
MAINTENANCE PAVING
(NO WIN PROJECT)
REGIONS 1 - 5
2022

Updated 05/15/2020

STATE PROJECT

MAINTENANCE & OPERATIONS

BIDDING INSTRUCTIONS

1. Use pen and ink to complete all paper Bids. Signatures shall be original. Stamped and copied signatures will not be accepted. Bids are not accepted by email or FAX.

NOTE: Electronic Bids will not be accepted for this bid.

2. As a minimum, the following should be received prior to the time of Bid opening: a) a copy of the Notice to Contractors, b) the completed Acknowledgement of Bid Amendments form, c) the completed Schedule of Items, d) two copies of the completed and signed Contract Agreement form, e) the completed Contractor Information Sheet, and f) any other certifications or Bid requirements listed in the Bid Documents as due by Bid opening.
3. Include prices for all items in the Schedule of Items for each Region bid.
4. All Bid Packages which are mailed or sent express, shall be provided in double (one envelope inside the other) envelopes, for security and other reasons. The *Inner Envelope* shall have the following information provided on it:

Bid Enclosed - Do Not Open

Title: On Call Maintenance Paving

Location: Regions 1 - 5

Date of Bid Opening: _____

Name of Contractor with mailing address and telephone number:

In Addition to the usual address information, the *Outer Envelope* should have written or typed on it:

Double Envelope: Bid Enclosed

Title: On Call Maintenance Paving

Location: Regions 1 - 5

Date of Bid Opening: _____

Name of Contractor:

If a paper Bid is to be sent express, please take note that overnight services do not always arrive in time and that delivery may be affected by carrier volume, weather and other factors.

Packages using express services should be sent directly to the DOT Headquarters Building, Maine Department of Transportation, 24 Child Street, Augusta. "FedEx First Overnight" delivery is suggested as the package is delivered directly to the DOT Headquarters Building, Mailroom, 24 Child Street, Augusta. Allow extra days for U.S. Postal Service Express Mail which has proven not to be reliable and sometimes does not deliver directly to the DOT Headquarters Building but instead delivers to the State of Maine Mail Distribution Center.

If a paper bid is to be mailed, the mailing address is Maine Department of Transportation, 16 State House Station, Augusta, ME 04333-0016. Allow additional working days for this mail to pass through the state mail system in addition to the US Postal Service as this mail is not delivered directly to the Department of Transportation.

If a paper Bid is to be hand carried, deliver directly to the "Public Entrance" which is located on the Capitol Street side of the DOT Headquarters Building in Augusta. <http://www.maine.gov/mdot/contact>. Hand-carried Bids may be in one envelope, and should be marked with the following information:

Bid Enclosed: Do Not Open

Title: On Call Maintenance Paving

Location: Regions 1 - 5

Date of Bid Opening: _____

Name of Contractor:

If you need further information regarding Bid preparation, call the DOT Contracts Section at (207) 624-3410.

For complete bidding requirements, refer to Section 102 of the Maine Department of Transportation, Standard Specifications, March 2020 Edition.

NOTICE

The Maine Department of Transportation is attempting to improve the way Bid Amendments/Addendums are handled, and allow for an electronic downloading of bid packages from our website, while continuing to maintain an optional plan holders list.

Prospective bidders, subcontractors or suppliers who wish to download a copy of the bid package and receive a courtesy notification of project specific bid amendments must fill out the on-line plan holder registration form and provide an email address to the MDOT Contracts mailbox at: MDOT.contracts@maine.gov. Each bid package will require a separate request.

Additionally, interested parties will be responsible for reviewing and retrieving the Bid Amendments from our web site, and acknowledging receipt and incorporating those Bid Amendments in their bids using the Acknowledgement of Bid Amendment Form.

NOTICE

Bidders:

Please use the attached “Request for Information” form when submitting questions concerning specific Contracts that have been advertised for Bid, include additional numbered pages as required. RFI’s may be faxed to 207-624-3431, submitted electronically through the Departments web page of advertised projects by selecting the RFI tab on the project details page or via e-mail to RFI-Contracts.MDOT@maine.gov.

These are the only allowable mechanisms for answering Project specific questions. Maine DOT will not be bound to any answers to Project specific questions received during the Bidding phase through other processes.

When submitting RFIs by Email please follow the same guidelines as stated on the “Request for Information” form and include the word “RFI” along with the Project name and Identification number in the subject line.

Vendor Registration

Prospective Bidders must register as a vendor with the Department of Administrative & Financial Services if the vendor is awarded a contract. Vendors will not be able to receive payment without first being registered. Vendors/Contractors will find information and register through the following link –

<http://www.maine.gov/purchases/venbid/index.shtml>

CONTRACTOR INFORMATION

Contractor Name: _____

Mailing Address: _____

Vendor Customer Number: _____

Contact Information (Primary Contact): _____

Phone: _____ **Cell Phone:** _____

Fax: _____

Email: _____

Mailing Address (if different from above): _____

The company has the following organizational structure:

Sole Proprietorship

Limited Liability Company

Partnership

Joint Venture

Corporation

Other: _____

(Date)

(Signature)

(Name and Title Printed)

STATE OF MAINE DEPARTMENT OF TRANSPORTATION NOTICE TO CONTRACTORS

Sealed Bids addressed to the Maine Department of Transportation, Augusta, Maine 04333 and endorsed on the wrapper “Bids for **On Call Maintenance Paving** in **REGIONS 1–5**” will be received from contractors at the Reception Desk, MaineDOT Building, Capitol Street, Augusta, Maine, until 11:00 o’clock A.M. (prevailing time) on **March 23, 2022**, and at that time and place, publicly opened and read. Bids will be accepted from all bidders. All responsive bidders must demonstrate successful completion of projects of similar size and scope to be considered for the award of this contract. **Electronic Bidding will not be available for this bid.**

Description: On Call Maintenance Paving

Location: In Regions 1 – 5

Outline of Work: Placing Hot Mix Asphalt Pavement or Plant Mix Recycled Asphalt Pavement, furnishing and operating equipment in conjunction with HMA or PMRAP placement, and other incidental work.

A bidder is not required to bid all zones or Regions, but may bid on one or more zones. Contracts may be awarded by zone, to each responsive, responsible bidder that meets the requirements and specifications.

For general information regarding Bidding and Contracting procedures, contact George Macdougall at (207) 624-3410. Our webpage at <http://www.maine.gov/mdot/contractors/> contains a copy of the Schedule of Items, Plan Holders List, written portions of bid amendments, bid results and an electronic form for RFI submittal. For Project-specific information fax all questions to **Gail Iler** at (207) 624-3431, use electronic RFI form or email questions to RFI-Contracts.MDOT@maine.gov, project name and identification number should be in the subject line. Questions received after 12:00 noon of Friday prior to bid date will not be answered. Bidders shall not contact any other Departmental staff for clarification of Contract provisions, and the Department will not be responsible for any interpretations so obtained. TTY users call Maine Relay 711.

Bid Documents, specifications and bid forms can be viewed and obtained digitally at no cost at <http://www.maine.gov/mdot/contractors/>. They may be seen at the MaineDOT Building in Augusta, Maine and at the Department of Transportation’s Regional Offices in Scarborough, Augusta, Wilton, Bangor and Presque Isle. They can be obtained at no cost at the Department at 24 Child Street, Augusta, ME, between the hours of 8:00 a.m. to 4:30 p.m., may be requested by telephone at (207) 624-3536 between the hours of 8:00 a.m. to 4:30 p.m., or from Maine Department of Transportation, Attn.: Mailroom, 16 State House Station, Augusta, Maine 04333-0016.

There will be no bid bond, performance bond or payment bond required.

Each Bid must be made upon blank forms provided by the Department.

This Contract is subject to all applicable State Laws.

All work shall be governed by *State of Maine, Department of Transportation, Standard Specifications, March 2020 Edition*, price \$10 [\$15 by mail], and *Standard Details, March 2020 Edition*, price \$10 [\$15 by mail]. They also may be purchased by telephone at (207) 624-3536 between the hours of 8:00 a.m. to 4:30 p.m. *Standard Detail* updates can be found at <http://www.maine.gov/mdot/contractors/publications/>.

The right is hereby reserved to the MaineDOT to reject any or all bids.

Augusta, Maine
March 2, 2022



DAVID BERNHARDT
DIRECTOR
BUREAU OF MAINTENANCE & OPERATIONS

**SPECIAL PROVISION 102.7.3
 ACKNOWLEDGMENT OF BID AMENDMENTS**

With this form, the Bidder acknowledges its responsibility to check for all Amendments to the Bid Package. For each Project under Advertisement, Amendments are located at <http://www.maine.gov/mdot/contractors/> . It is the responsibility of the Bidder to determine if there are Amendments to the Project, to download them, to incorporate them into their Bid Package, and to reference the Amendment number and the date on the form below. The Maine DOT will not post Bid Amendments any later than noon the day before Bid opening without individually notifying all the planholders.

Amendment Number	Date

The Contractor, for itself, its successors and assigns, hereby acknowledges that it has received all of the above referenced Amendments to the Bid Package.

CONTRACTOR

_____ Date

_____ Signature of authorized representative

_____ (Name and Title Printed)

**Maine Department of Transportation
 On Call Maintenance Paving 2022
 Schedule of Items**

<u>AREA</u>	<u>CLASS I PAVING TRAIN</u>	<u>CLASS II PAVING TRAIN</u>	<u>CLASS III PAVING TRAIN</u>
<u>REGION 1</u>			
ZONE 1	_____ per hour	_____ per hour	_____ per hour
<u>REGION 2</u>			
ZONE 2	_____ per hour	_____ per hour	_____ per hour
ZONE 3	_____ per hour	_____ per hour	_____ per hour
ZONE 4	_____ per hour	_____ per hour	_____ per hour
<u>REGION 3</u>			
ZONE 5	_____ per hour	_____ per hour	_____ per hour
ZONE 6	_____ per hour	_____ per hour	_____ per hour

By signing below, the Bidder (1) represents that the Bidder has examined the Contract Agreement contained in the Bid Documents, the Contract, all documents referenced in said Contract, and the site and scope of work, (2) does hereby bid and offer to enter into this contract to construct and/or perform the Work in strict accordance with the terms and conditions of this Contract at the unit prices bid in the attached "Schedule of Items", (3) represents that the Bidder has given the Department notice of any errors or ambiguities related to the documents or the work that have been discovered by the Bidder, (4) represents that the above-named organization is the legal entity entering into the resulting contract with the Department if they are awarded the contract and, (5) represents that the undersigned is authorized to enter contractual obligations on behalf of the above-named organization.

Bidder acknowledges that the properly completed and signed Schedule of Items provided with the Bid constitutes the Bidder's offer and that this offer shall remain open for 30 calendar days after the date of opening of bids.

The Bidder hereby certifies, to the best of its knowledge and belief that: the Bidder has not, either directly or indirectly, entered into any agreement, participated in any collusion, or otherwise taken any action in restraint of competitive bidding in connection with its bid, and its subsequent contract with the Department.

Use pen and ink to complete paper bids. Signatures shall be original. Stamped and copied signatures will not be accepted.

_____ _____
Signature *Date*

 (Print Bidder's Name and Title)

**Maine Department of Transportation
On Call Maintenance Paving 2022
Schedule of Items**

<u>AREA</u>	<u>CLASS I PAVING TRAIN</u>	<u>CLASS II PAVING TRAIN</u>	<u>CLASS III PAVING TRAIN</u>
<u>REGION 4</u>			
ZONE 7	_____ per hour	_____ per hour	_____ per hour
ZONE 8	_____ per hour	_____ per hour	_____ per hour
ZONE 9	_____ per hour	_____ per hour	_____ per hour
<u>REGION 5</u>			
ZONE 10	_____ per hour	_____ per hour	_____ per hour
ZONE 11	_____ per hour	_____ per hour	_____ per hour
ZONE 12	_____ per hour	_____ per hour	_____ per hour

By signing below, the Bidder (1) represents that the Bidder has examined the Contract Agreement contained in the Bid Documents, the Contract, all documents referenced in said Contract, and the site and scope of work, (2) does hereby bid and offer to enter into this contract to construct and/or perform the Work in strict accordance with the terms and conditions of this Contract at the unit prices bid in the attached "Schedule of Items", (3) represents that the Bidder has given the Department notice of any errors or ambiguities related to the documents or the work that have been discovered by the Bidder, (4) represents that the above-named organization is the legal entity entering into the resulting contract with the Department if they are awarded the contract and, (5) represents that the undersigned is authorized to enter contractual obligations on behalf of the above-named organization.

Bidder acknowledges that the properly completed and signed Schedule of Items provided with the Bid constitutes the Bidder's offer and that this offer shall remain open for 30 calendar days after the date of opening of bids.

The Bidder hereby certifies, to the best of its knowledge and belief that: the Bidder has not, either directly or indirectly, entered into any agreement, participated in any collusion, or otherwise taken any action in restraint of competitive bidding in connection with its bid, and its subsequent contract with the Department.

Use pen and ink to complete paper bids. Signatures shall be original. Stamped and copied signatures will not be accepted.

Signature

Date

(Print Bidder's Name and Title)

**Maine Department of Transportation
On Call Maintenance Paving 2022
Schedule of Items**

<u>AREA</u>	<u>CLASS IV HAND CREW</u>	<u>ITEM 631.133 SKID STEER</u>	<u>ITEM 631.172 TRUCK - LARGE</u>
<u>REGION 1</u>			
ZONE 1	_____ per hour	_____ per hour	_____ per hour
<u>REGION 2</u>			
ZONE 2	_____ per hour	_____ per hour	_____ per hour
ZONE 3	_____ per hour	_____ per hour	_____ per hour
ZONE 4	_____ per hour	_____ per hour	_____ per hour
<u>REGION 3</u>			
ZONE 5	_____ per hour	_____ per hour	_____ per hour
ZONE 6	_____ per hour	_____ per hour	_____ per hour

By signing below, the Bidder (1) represents that the Bidder has examined the Contract Agreement contained in the Bid Documents, the Contract, all documents referenced in said Contract, and the site and scope of work, (2) does hereby bid and offer to enter into this contract to construct and/or perform the Work in strict accordance with the terms and conditions of this Contract at the unit prices bid in the attached "Schedule of Items", (3) represents that the Bidder has given the Department notice of any errors or ambiguities related to the documents or the work that have been discovered by the Bidder, (4) represents that the above-named organization is the legal entity entering into the resulting contract with the Department if they are awarded the contract and, (5) represents that the undersigned is authorized to enter contractual obligations on behalf of the above-named organization.

Bidder acknowledges that the properly completed and signed Schedule of Items provided with the Bid constitutes the Bidder's offer and that this offer shall remain open for 30 calendar days after the date of opening of bids.

The Bidder hereby certifies, to the best of its knowledge and belief that: the Bidder has not, either directly or indirectly, entered into any agreement, participated in any collusion, or otherwise taken any action in restraint of competitive bidding in connection with its bid, and its subsequent contract with the Department.

Use pen and ink to complete paper bids. Signatures shall be original. Stamped and copied signatures will not be accepted.

_____ _____
Signature *Date*

(Print Bidder's Name and Title)

**Maine Department of Transportation
On Call Maintenance Paving 2022
Schedule of Items**

<u>AREA</u>	<u>CLASS IV HAND CREW</u>	<u>ITEM 631.133 SKID STEER</u>	<u>ITEM 631.172 TRUCK - LARGE</u>
<u>REGION 4</u>			
ZONE 7	_____ per hour	_____ per hour	_____ per hour
ZONE 8	_____ per hour	_____ per hour	_____ per hour
ZONE 9	_____ per hour	_____ per hour	_____ per hour
<u>REGION 5</u>			
ZONE 10	_____ per hour	_____ per hour	_____ per hour
ZONE 11	_____ per hour	_____ per hour	_____ per hour
ZONE 12	_____ per hour	_____ per hour	_____ per hour

By signing below, the Bidder (1) represents that the Bidder has examined the Contract Agreement contained in the Bid Documents, the Contract, all documents referenced in said Contract, and the site and scope of work, (2) does hereby bid and offer to enter into this contract to construct and/or perform the Work in strict accordance with the terms and conditions of this Contract at the unit prices bid in the attached "Schedule of Items", (3) represents that the Bidder has given the Department notice of any errors or ambiguities related to the documents or the work that have been discovered by the Bidder, (4) represents that the above-named organization is the legal entity entering into the resulting contract with the Department if they are awarded the contract and, (5) represents that the undersigned is authorized to enter contractual obligations on behalf of the above-named organization.

Bidder acknowledges that the properly completed and signed Schedule of Items provided with the Bid constitutes the Bidder's offer and that this offer shall remain open for 30 calendar days after the date of opening of bids.

The Bidder hereby certifies, to the best of its knowledge and belief that: the Bidder has not, either directly or indirectly, entered into any agreement, participated in any collusion, or otherwise taken any action in restraint of competitive bidding in connection with its bid, and its subsequent contract with the Department.

Use pen and ink to complete paper bids. Signatures shall be original. Stamped and copied signatures will not be accepted.

Signature

Date

(Print Bidder's Name and Title)

**Maine Department of Transportation
On Call Maintenance Paving 2022
Schedule of Items**

<u>AREA</u>	<u>ITEM 659.11 MOBILIZATION HOURLY</u>	<u>ITEM 659.12 MOBILIZATION OVERNIGHT</u>	<u>ITEM 659.13 MOBILIZATION NIGHT WORK</u>
<u>REGION 1</u>			
ZONE 1	_____ per hour	_____ per CD	_____ per CD
<u>REGION 2</u>			
ZONE 2	_____ per hour	_____ per CD	_____ per CD
ZONE 3	_____ per hour	_____ per CD	_____ per CD
ZONE 4	_____ per hour	_____ per CD	_____ per CD
<u>REGION 3</u>			
ZONE 5	_____ per hour	_____ per CD	_____ per CD
ZONE 6	_____ per hour	_____ per CD	_____ per CD

By signing below, the Bidder (1) represents that the Bidder has examined the Contract Agreement contained in the Bid Documents, the Contract, all documents referenced in said Contract, and the site and scope of work, (2) does hereby bid and offer to enter into this contract to construct and/or perform the Work in strict accordance with the terms and conditions of this Contract at the unit prices bid in the attached "Schedule of Items", (3) represents that the Bidder has given the Department notice of any errors or ambiguities related to the documents or the work that have been discovered by the Bidder, (4) represents that the above-named organization is the legal entity entering into the resulting contract with the Department if they are awarded the contract and, (5) represents that the undersigned is authorized to enter contractual obligations on behalf of the above-named organization.

Bidder acknowledges that the properly completed and signed Schedule of Items provided with the Bid constitutes the Bidder's offer and that this offer shall remain open for 30 calendar days after the date of opening of bids.

The Bidder hereby certifies, to the best of its knowledge and belief that: the Bidder has not, either directly or indirectly, entered into any agreement, participated in any collusion, or otherwise taken any action in restraint of competitive bidding in connection with its bid, and its subsequent contract with the Department.

Use pen and ink to complete paper bids. Signatures shall be original. Stamped and copied signatures will not be accepted.

Signature

Date

(Print Bidder's Name and Title)

**Maine Department of Transportation
On Call Maintenance Paving 2022
Schedule of Items**

<u>AREA</u>	<u>ITEM 659.11 MOBILIZATION HOURLY</u>	<u>ITEM 659.12 MOBILIZATION OVERNIGHT</u>	<u>ITEM 659.13 MOBILIZATION NIGHT WORK</u>
<u>REGION 4</u>			
ZONE 7	_____ per hour	_____ per CD	_____ per CD
ZONE 8	_____ per hour	_____ per CD	_____ per CD
ZONE 9	_____ per hour	_____ per CD	_____ per CD
<u>REGION 5</u>			
ZONE 10	_____ per hour	_____ per CD	_____ per CD
ZONE 11	_____ per hour	_____ per CD	_____ per CD
ZONE 12	_____ per hour	_____ per CD	_____ per CD

By signing below, the Bidder (1) represents that the Bidder has examined the Contract Agreement contained in the Bid Documents, the Contract, all documents referenced in said Contract, and the site and scope of work, (2) does hereby bid and offer to enter into this contract to construct and/or perform the Work in strict accordance with the terms and conditions of this Contract at the unit prices bid in the attached "Schedule of Items", (3) represents that the Bidder has given the Department notice of any errors or ambiguities related to the documents or the work that have been discovered by the Bidder, (4) represents that the above-named organization is the legal entity entering into the resulting contract with the Department if they are awarded the contract and, (5) represents that the undersigned is authorized to enter contractual obligations on behalf of the above-named organization.

Bidder acknowledges that the properly completed and signed Schedule of Items provided with the Bid constitutes the Bidder's offer and that this offer shall remain open for 30 calendar days after the date of opening of bids.

The Bidder hereby certifies, to the best of its knowledge and belief that: the Bidder has not, either directly or indirectly, entered into any agreement, participated in any collusion, or otherwise taken any action in restraint of competitive bidding in connection with its bid, and its subsequent contract with the Department.

Use pen and ink to complete paper bids. Signatures shall be original. Stamped and copied signatures will not be accepted.

_____ _____
Signature *Date*

(Print Bidder's Name and Title)

**Maine Department of Transportation
 On Call Maintenance Paving 2022
 Schedule of Items**

<u>AREA</u>	<u>ITEM 409.15 TACK</u>	<u>DISTRIBUTOR TRUCK</u>
<u>REGION 1</u>		
ZONE 1	_____ per gallon	_____ per hour
<u>REGION 2</u>		
ZONE 2	_____ per gallon	_____ per hour
ZONE 3	_____ per gallon	_____ per hour
ZONE 4	_____ per gallon	_____ per hour
<u>REGION 3</u>		
ZONE 5	_____ per gallon	_____ per hour
ZONE 6	_____ per gallon	_____ per hour

By signing below, the Bidder (1) represents that the Bidder has examined the Contract Agreement contained in the Bid Documents, the Contract, all documents referenced in said Contract, and the site and scope of work, (2) does hereby bid and offer to enter into this contract to construct and/or perform the Work in strict accordance with the terms and conditions of this Contract at the unit prices bid in the attached "Schedule of Items", (3) represents that the Bidder has given the Department notice of any errors or ambiguities related to the documents or the work that have been discovered by the Bidder, (4) represents that the above-named organization is the legal entity entering into the resulting contract with the Department if they are awarded the contract and, (5) represents that the undersigned is authorized to enter contractual obligations on behalf of the above-named organization.

Bidder acknowledges that the properly completed and signed Schedule of Items provided with the Bid constitutes the Bidder's offer and that this offer shall remain open for 30 calendar days after the date of opening of bids.

The Bidder hereby certifies, to the best of its knowledge and belief that: the Bidder has not, either directly or indirectly, entered into any agreement, participated in any collusion, or otherwise taken any action in restraint of competitive bidding in connection with its bid, and its subsequent contract with the Department.

Use pen and ink to complete paper bids. Signatures shall be original. Stamped and copied signatures will not be accepted.

_____ _____
Signature *Date*

(Print Bidder's Name and Title)

**Maine Department of Transportation
On Call Maintenance Paving 2022
Schedule of Items**

<u>AREA</u>	<u>ITEM 409.15 TACK</u>	<u>DISTRIBUTOR TRUCK</u>
<u>REGION 4</u>		
ZONE 7	_____ per gallon	_____ per hour
ZONE 8	_____ per gallon	_____ per hour
ZONE 9	_____ per gallon	_____ per hour
<u>REGION 5</u>		
ZONE 10	_____ per gallon	_____ per hour
ZONE 11	_____ per gallon	_____ per hour
ZONE 12	_____ per gallon	_____ per hour

By signing below, the Bidder (1) represents that the Bidder has examined the Contract Agreement contained in the Bid Documents, the Contract, all documents referenced in said Contract, and the site and scope of work, (2) does hereby bid and offer to enter into this contract to construct and/or perform the Work in strict accordance with the terms and conditions of this Contract at the unit prices bid in the attached "Schedule of Items", (3) represents that the Bidder has given the Department notice of any errors or ambiguities related to the documents or the work that have been discovered by the Bidder, (4) represents that the above-named organization is the legal entity entering into the resulting contract with the Department if they are awarded the contract and, (5) represents that the undersigned is authorized to enter contractual obligations on behalf of the above-named organization.

Bidder acknowledges that the properly completed and signed Schedule of Items provided with the Bid constitutes the Bidder's offer and that this offer shall remain open for 30 calendar days after the date of opening of bids.

The Bidder hereby certifies, to the best of its knowledge and belief that: the Bidder has not, either directly or indirectly, entered into any agreement, participated in any collusion, or otherwise taken any action in restraint of competitive bidding in connection with its bid, and its subsequent contract with the Department.

Use pen and ink to complete paper bids. Signatures shall be original. Stamped and copied signatures will not be accepted.

Signature _____ *Date*

(Print Bidder's Name and Title)

**Maine Department of Transportation
On Call Maintenance Paving 2022
Schedule of Items**

<u>AREA</u>	<u>PAVEMENT BUTT JOINT LESS THAN 250 SY</u>	<u>PAVEMENT BUTT JOINT GREATER THAN 250 SY</u>	<u>ITEM 609.31 BITUMINOUS CURB</u>
<u>REGION 1</u>			
ZONE 1	_____ per SY	_____ per SY	_____ per foot
<u>REGION 2</u>			
ZONE 2	_____ per SY	_____ per SY	_____ per foot
ZONE 3	_____ per SY	_____ per SY	_____ per foot
ZONE 4	_____ per SY	_____ per SY	_____ per foot
<u>REGION 3</u>			
ZONE 5	_____ per SY	_____ per SY	_____ per foot
ZONE 6	_____ per SY	_____ per SY	_____ per foot

By signing below, the Bidder (1) represents that the Bidder has examined the Contract Agreement contained in the Bid Documents, the Contract, all documents referenced in said Contract, and the site and scope of work, (2) does hereby bid and offer to enter into this contract to construct and/or perform the Work in strict accordance with the terms and conditions of this Contract at the unit prices bid in the attached "Schedule of Items", (3) represents that the Bidder has given the Department notice of any errors or ambiguities related to the documents or the work that have been discovered by the Bidder, (4) represents that the above-named organization is the legal entity entering into the resulting contract with the Department if they are awarded the contract and, (5) represents that the undersigned is authorized to enter contractual obligations on behalf of the above-named organization.

Bidder acknowledges that the properly completed and signed Schedule of Items provided with the Bid constitutes the Bidder's offer and that this offer shall remain open for 30 calendar days after the date of opening of bids.

The Bidder hereby certifies, to the best of its knowledge and belief that: the Bidder has not, either directly or indirectly, entered into any agreement, participated in any collusion, or otherwise taken any action in restraint of competitive bidding in connection with its bid, and its subsequent contract with the Department.

Use pen and ink to complete paper bids. Signatures shall be original. Stamped and copied signatures will not be accepted.

_____ _____
Signature *Date*

(Print Bidder's Name and Title)

**Maine Department of Transportation
On Call Maintenance Paving 2022
Schedule of Items**

<u>AREA</u>	<u>PAVEMENT BUTT JOINT LESS THAN 250 SY</u>	<u>PAVEMENT BUTT JOINT GREATER THAN 250 SY</u>	<u>ITEM 609.31 BITUMINOUS CURB</u>
 <u>REGION 4</u>			
ZONE 7	_____ per SY	_____ per SY	_____ per foot
ZONE 8	_____ per SY	_____ per SY	_____ per foot
ZONE 9	_____ per SY	_____ per SY	_____ per foot
 <u>REGION 5</u>			
ZONE 10	_____ per SY	_____ per SY	_____ per foot
ZONE 11	_____ per SY	_____ per SY	_____ per foot
ZONE 12	_____ per SY	_____ per SY	_____ per foot

By signing below, the Bidder (1) represents that the Bidder has examined the Contract Agreement contained in the Bid Documents, the Contract, all documents referenced in said Contract, and the site and scope of work, (2) does hereby bid and offer to enter into this contract to construct and/or perform the Work in strict accordance with the terms and conditions of this Contract at the unit prices bid in the attached "Schedule of Items", (3) represents that the Bidder has given the Department notice of any errors or ambiguities related to the documents or the work that have been discovered by the Bidder, (4) represents that the above-named organization is the legal entity entering into the resulting contract with the Department if they are awarded the contract and, (5) represents that the undersigned is authorized to enter contractual obligations on behalf of the above-named organization.

Bidder acknowledges that the properly completed and signed Schedule of Items provided with the Bid constitutes the Bidder's offer and that this offer shall remain open for 30 calendar days after the date of opening of bids.

The Bidder hereby certifies, to the best of its knowledge and belief that: the Bidder has not, either directly or indirectly, entered into any agreement, participated in any collusion, or otherwise taken any action in restraint of competitive bidding in connection with its bid, and its subsequent contract with the Department.

Use pen and ink to complete paper bids. Signatures shall be original. Stamped and copied signatures will not be accepted.

_____ _____
Signature *Date*

(Print Bidder's Name and Title)

**Electronic bidding will NOT be available
for this bid.**

**Bids will NOT be accepted
by email or fax.**

**SIGNED PAPER BIDS ARE REQUIRED
and may be
mailed, sent express or hand delivered.**

For further information, see “BIDDING INSTRUCTIONS”
which are located near the front of the bid book.

CONTRACT AGREEMENT, OFFER & AWARD

AGREEMENT made on the date last signed below, by and between the State of Maine, acting through and by its Department of Transportation (Department), an agency of state government with its principal administrative offices located at Child Street, Augusta, Maine, with a mailing address at 16 State House Station, Augusta, Maine 04333-0016, and _____ (Contractor) a corporation or other legal entity organized under the laws of the State of _____, with its principal place of business located at _____.

The Department and the Contractor, in consideration of the mutual promises set forth in this Agreement (the "Contract"), hereby agree as follows:

A. The Work.

The Contractor agrees to complete all Work as specified or indicated in the Contract including Extra Work in conformity with the Contract, **On Call Maintenance Paving**, in the zones awarded in the State of Maine. The Work includes construction, maintenance during construction, warranty as provided in the Contract, and other incidental work.

The Contractor shall be responsible for furnishing all supervision, labor, equipment, tools supplies, permanent materials and temporary materials required to perform the Work including construction quality control including inspection, testing and documentation, all required documentation at the conclusion of the project, warranting its work and performing all other work indicated in the Contract.

The Department shall have the right to alter the nature and extent of the Work as provided in the Contract; payment to be made as provided in the same.

B. Time.

The Contractor agrees to complete all Work, beginning after contract execution or **April 1, 2022** whichever is latest and continuing until this contract expires on **March 31, 2023**.

C. Price.

The regions in which Bids are received and accepted and Special Provision Section 103 Basis of Award will be used as the basis for determining the original Contract amount. The Department does not guarantee the use of any or all of the Contract amount. The final Contract amount will be determined by the actual work authorized and performed at bid prices.

D. Contract.

This Contract, which may be amended, modified, or supplemented in writing only, consists of the Contract documents as defined in the Plans, *Standard Specifications, March 2020 Edition, Standard Details March 2020 Edition* as updated through advertisement, Supplemental Specifications, Special Provisions, and Contract Agreement. It is agreed and understood that this Contract will be governed by the documents listed above.

E. Certifications.

By signing below, the Contractor hereby certifies that to the best of the Contractor's knowledge and belief:

1. All of the statements, representations, covenants, and/or certifications required or set forth in the Bid and the Bid Documents, including those in the Contract are still complete and accurate as of the date of this Agreement.
2. The Contractor knows of no legal, contractual, or financial impediment to entering into this Contract.
3. The person signing below is legally authorized by the Contractor to sign this Contract on behalf of the Contractor and to legally bind the Contractor to the terms of the Contract.

F. Offer.

The undersigned, having carefully examined the site of work, the Plans, *Standard Specifications March 2020 Edition*, *Standard Details March 2020 Edition* as updated through advertisement, Supplemental Specifications, Special Provisions, and Contract Agreement; contained herein for **On Call Maintenance Paving** in the Regions awarded in the State of Maine, on which bids will be received until the time specified in the “Notice to Contractors” do(es) hereby bid and offer to enter into this contract to supply all the materials, tools, equipment and labor to construct the whole of the Work in strict accordance with the terms and conditions of this Contract at the unit prices in the attached “Schedule of Items.”

The Offeror agrees to perform the work required at the price specified above and in accordance with the bids provided in the attached “Schedule of Items” in strict accordance with the terms of this solicitation, and to provide the appropriate insurance if this offer is accepted by the Government in writing.

As Offeror also agrees:

First: To do any extra work, not covered by the attached “Schedule of Items,” which may be ordered by the Resident, and to accept as full compensation the amount determined upon a “Force Account” basis as provided in the *Standard Specifications, March 2020 Edition*, and as addressed in the contract documents.

Second: That this offer shall remain open for 30 calendar days after the date of opening of bids.

Third: The Bidder hereby certifies, to the best of its knowledge and belief that: the Bidder has not, either directly or indirectly, entered into any agreement, participated in any collusion, or otherwise taken any action in restraint of competitive bidding in connection with its bid, and its subsequent contract with the Department.

IN WITNESS WHEREOF, the Contractor, for itself, its successors and assigns, hereby execute this Agreement and thereby binds itself to all covenants, terms, and obligations contained in the Contract Documents.

CONTRACTOR

Date

(Signature of Legally Authorized Representative
of the Contractor)

Witness

(Name and Title Printed)

G. Award.

Your offer is hereby accepted for (see marked boxes):

Region 1 Zone 1

Region 2 Zone 2

 Zone 3

 Zone 4

Region 3 Zone 5

 Zone 6

Region 4 Zone 7

 Zone 8

 Zone 9

Region 5 Zone 10

 Zone 11

 Zone 12

The original contract amount is: \$ _____

_____.

This award consummates the Contract, and the documents referenced herein.

MAINE DEPARTMENT OF TRANSPORTATION

Date

By: David Bernhardt
Director
Bureau of Maintenance & Operations

CONTRACT AGREEMENT, OFFER & AWARD

AGREEMENT made on the date last signed below, by and between the State of Maine, acting through and by its Department of Transportation (Department), an agency of state government with its principal administrative offices located at Child Street, Augusta, Maine, with a mailing address at 16 State House Station, Augusta, Maine 04333-0016, and _____ (Contractor) a corporation or other legal entity organized under the laws of the State of _____, with its principal place of business located at _____.

The Department and the Contractor, in consideration of the mutual promises set forth in this Agreement (the "Contract"), hereby agree as follows:

A. The Work.

The Contractor agrees to complete all Work as specified or indicated in the Contract including Extra Work in conformity with the Contract, **On Call Maintenance Paving**, in the zones awarded in the State of Maine. The Work includes construction, maintenance during construction, warranty as provided in the Contract, and other incidental work.

The Contractor shall be responsible for furnishing all supervision, labor, equipment, tools supplies, permanent materials and temporary materials required to perform the Work including construction quality control including inspection, testing and documentation, all required documentation at the conclusion of the project, warranting its work and performing all other work indicated in the Contract.

The Department shall have the right to alter the nature and extent of the Work as provided in the Contract; payment to be made as provided in the same.

B. Time.

The Contractor agrees to complete all Work, beginning after contract execution or **April 1, 2022** whichever is latest and continuing until this contract expires on **March 31, 2023**.

C. Price.

The regions in which Bids are received and accepted and Special Provision Section 103 Basis of Award will be used as the basis for determining the original Contract amount. The Department does not guarantee the use of any or all of the Contract amount. The final Contract amount will be determined by the actual work authorized and performed at bid prices.

D. Contract.

This Contract, which may be amended, modified, or supplemented in writing only, consists of the Contract documents as defined in the Plans, *Standard Specifications, March 2020 Edition, Standard Details March 2020 Edition* as updated through advertisement, Supplemental Specifications, Special Provisions, and Contract Agreement. It is agreed and understood that this Contract will be governed by the documents listed above.

E. Certifications.

By signing below, the Contractor hereby certifies that to the best of the Contractor's knowledge and belief:

1. All of the statements, representations, covenants, and/or certifications required or set forth in the Bid and the Bid Documents, including those in the Contract are still complete and accurate as of the date of this Agreement.
2. The Contractor knows of no legal, contractual, or financial impediment to entering into this Contract.
3. The person signing below is legally authorized by the Contractor to sign this Contract on behalf of the Contractor and to legally bind the Contractor to the terms of the Contract.

F. Offer.

The undersigned, having carefully examined the site of work, the Plans, *Standard Specifications March 2020 Edition*, *Standard Details March 2020 Edition* as updated through advertisement, Supplemental Specifications, Special Provisions, and Contract Agreement; contained herein for **On Call Maintenance Paving** in the Regions awarded in the State of Maine, on which bids will be received until the time specified in the “Notice to Contractors” do(es) hereby bid and offer to enter into this contract to supply all the materials, tools, equipment and labor to construct the whole of the Work in strict accordance with the terms and conditions of this Contract at the unit prices in the attached “Schedule of Items.”

The Offeror agrees to perform the work required at the price specified above and in accordance with the bids provided in the attached “Schedule of Items” in strict accordance with the terms of this solicitation, and to provide the appropriate insurance if this offer is accepted by the Government in writing.

As Offeror also agrees:

First: To do any extra work, not covered by the attached “Schedule of Items,” which may be ordered by the Resident, and to accept as full compensation the amount determined upon a “Force Account” basis as provided in the *Standard Specifications, March 2020 Edition*, and as addressed in the contract documents.

Second: That this offer shall remain open for 30 calendar days after the date of opening of bids.

Third: The Bidder hereby certifies, to the best of its knowledge and belief that: the Bidder has not, either directly or indirectly, entered into any agreement, participated in any collusion, or otherwise taken any action in restraint of competitive bidding in connection with its bid, and its subsequent contract with the Department.

IN WITNESS WHEREOF, the Contractor, for itself, its successors and assigns, hereby execute this Agreement and thereby binds itself to all covenants, terms, and obligations contained in the Contract Documents.

CONTRACTOR

Date

(Signature of Legally Authorized Representative
of the Contractor)

Witness

(Name and Title Printed)

G. Award.

Your offer is hereby accepted for (see marked boxes):

Region 1 Zone 1

Region 2 Zone 2

Zone 3

Zone 4

Region 3 Zone 5

Zone 6

Region 4 Zone 7

Zone 8

Zone 9

Region 5 Zone 10

Zone 11

Zone 12

The original contract amount is: \$ _____

_____.

This award consummates the Contract, and the documents referenced herein.

MAINE DEPARTMENT OF TRANSPORTATION

Date

By: David Bernhardt
Director
Bureau of Maintenance & Operations

CONTRACT AGREEMENT, OFFER & AWARD

AGREEMENT made on the date last signed below, by and between the State of Maine, acting through and by its Department of Transportation (Department), an agency of state government with its principal administrative offices located at Child Street, Augusta, Maine, with a mailing address at 16 State House Station, Augusta, Maine 04333-0016, and _____ **(Name of the firm bidding the job)** **(Contractor)** a corporation or other legal entity organized under the laws of the State of Maine, with its principal place of business located at _____ **(address of the firm bidding the job)**

The Department and the Contractor, in consideration of the mutual promises set forth in this Agreement (the "Contract"), hereby agree as follows:

A. The Work.

The Contractor agrees to complete all Work as specified or indicated in the Contract including Extra Work in conformity with the Contract, **WIN 12345.00**, for the **Hot Mix Asphalt Overlay** in the town/city of **South Nowhere**, County of **Washington**, Maine. The Work includes construction, maintenance during construction, warranty as provided in the Contract, and other incidental work.

The Contractor shall be responsible for furnishing all supervision, labor, equipment, tools supplies, permanent materials and temporary materials required to perform the Work including construction quality control including inspection, testing and documentation, all required documentation at the conclusion of the project, warranting its work and performing all other work indicated in the Contract.

The Department shall have the right to alter the nature and extent of the Work as provided in the Contract; payment to be made as provided in the same.

B. Time.

The Contractor agrees to complete all Work, except warranty work, on or before **November 15, 2006**. Further, the Department may deduct from moneys otherwise due the Contractor, not as a penalty, but as Liquidated Damages in accordance with Sections 107.7 and 107.8 of the *State of Maine Department of Transportation Standard Specifications, March 2020 Edition* and related Special Provisions.

C. Price.

The quantities given in the Schedule of Items of the Bid Package will be used as the basis for determining the original Contract amount and for determining the amounts of the required Performance Surety Bond and Payment Surety Bond, and that the amount of this offer is

Section 1 - \$ (Place bid here in alphabetical form such as One Hundred Two dollars)

\$ (repeat bid here in numerical terms, such as \$102.00)

Section 2 \$ (Place bid here in alphabetical form such as Two Hundred dollars)

\$ (repeat bid here in numerical terms, such as \$200.00)

Performance Bond and Payment Bond each being 100% of the amount of this Contract.

D. Contract.

This Contract, which may be amended, modified, or supplemented in writing only, consists of the Contract documents as defined in the Plans, *Standard Specifications, March 2020 Edition, Standard Details March 2020 Edition*, Supplemental Specifications, Special Provisions, Contract Agreement; and Contract Bonds. It is agreed and understood that this Contract will be governed by the documents listed above.

E. Certifications.

By signing below, the Contractor hereby certifies that to the best of the Contractor's knowledge and belief:

1. All of the statements, representations, covenants, and/or certifications required or set forth in the Bid and the Bid Documents, including those in Appendix A to Division 100 of the *Standard Specifications March 2020 Edition* (Federal Contract Provisions Supplement), and the Contract are still complete and accurate as of the date of this Agreement.
2. The Contractor knows of no legal, contractual, or financial impediment to entering into this Contract.
3. The person signing below is legally authorized by the Contractor to sign this Contract on behalf of the Contractor and to legally bind the Contractor to the terms of the Contract.

F. Offer.

The undersigned, having carefully examined the site of work, the Plans, *Standard Specifications, March 2020 Edition, Standard Details March 2020 Edition, Supplemental Specifications, Special Provisions, Contract Agreement; and Contract Bonds* contained herein for construction of:

WIN 012345.00 South Nowhere, Hot Mix Asphalt Overlay

State of Maine, on which bids will be received until the time specified in the “Notice to Contractors” do(es) hereby bid and offer to enter into this contract to supply all the materials, tools, equipment and labor to construct the whole of the Work in strict accordance with the terms and conditions of this Contract at the unit prices in the attached “Schedule of Items.”

The Offeror agrees to perform the work required at the price specified above and in accordance with the bids provided in the attached “Schedule of Items” in strict accordance with the terms of this solicitation, and to provide the appropriate insurance and bonds if this offer is accepted by the Government in writing.

As Offeror also agrees:

First: To do any extra work, not covered by the attached “Schedule of Items,” which may be ordered by the Resident, and to accept as full compensation the amount determined upon a “Force Account” basis as provided in the *Standard Specifications, March 2020 Edition*, and as addressed in the contract documents.

Second: That the bid bond at 5% of the bid amount or the official bank check, cashier’s check, certificate of deposit or U. S. Postal Money Order in the amount given in the “Notice to Contractors”, payable to the Treasurer of the State of Maine and accompanying this bid, shall be forfeited, as liquidated damages, if in case this bid is accepted, and the undersigned shall fail to abide by the terms and conditions of the offer and fail to furnish satisfactory insurance and Contract bonds under the conditions stipulated in the Specifications within 15 days of notice of intent to award the contract.

Third: To begin the Work as stated in Section 107.2 of the *Standard Specifications March 2020 Edition* and complete the Work within the time limits given in the Special Provisions of this Contract.

Fourth: The Contractor will be bound to the Disadvantaged Business Enterprise (DBE) Requirements contained in the attached Notice (Additional Instructions to Bidders) and submit a completed Contractor’s Disadvantaged Business Enterprise Utilization Plan with their bid.

Fifth: That this offer shall remain open for 30 calendar days after the date of opening of bids.

Sixth: The Bidder hereby certifies, to the best of its knowledge and belief that: the Bidder has not, either directly or indirectly, entered into any agreement, participated in any collusion, or otherwise taken any action in restraint of competitive bidding in connection with its bid, and its subsequent contract with the Department.

IN WITNESS WHEREOF, the Contractor, for itself, its successors and assigns, hereby execute this Agreement and thereby binds itself to all covenants, terms, and obligations contained in the Contract Documents.

(Print Date here)
Date

(Sign Here)
(Signature of Legally Authorized Representative of the Contractor)

(Witness Sign Here)
Witness

(Print Name Here)
(Name and Title Printed)

G. Award.

Your offer is hereby accepted for (see checked boxes):

- Section 1
- Section 2

The original contract amount is: \$ _____

_____.

MAINE DEPARTMENT OF TRANSPORTATION

Date

By: Brian T. Burne
Highway Maintenance Engineer
Bureau of Maintenance & Operations

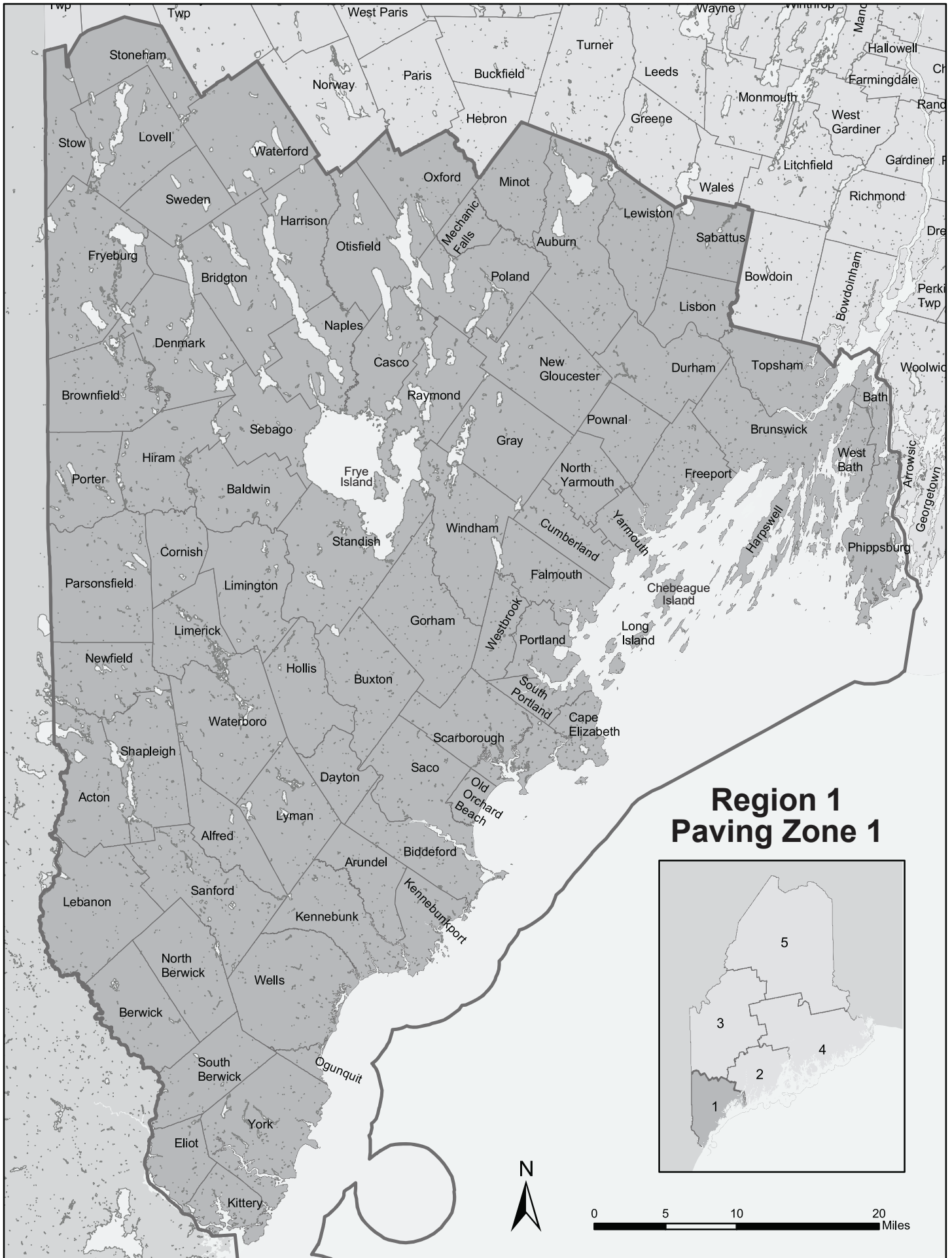

Region 2 Paving Zone 2

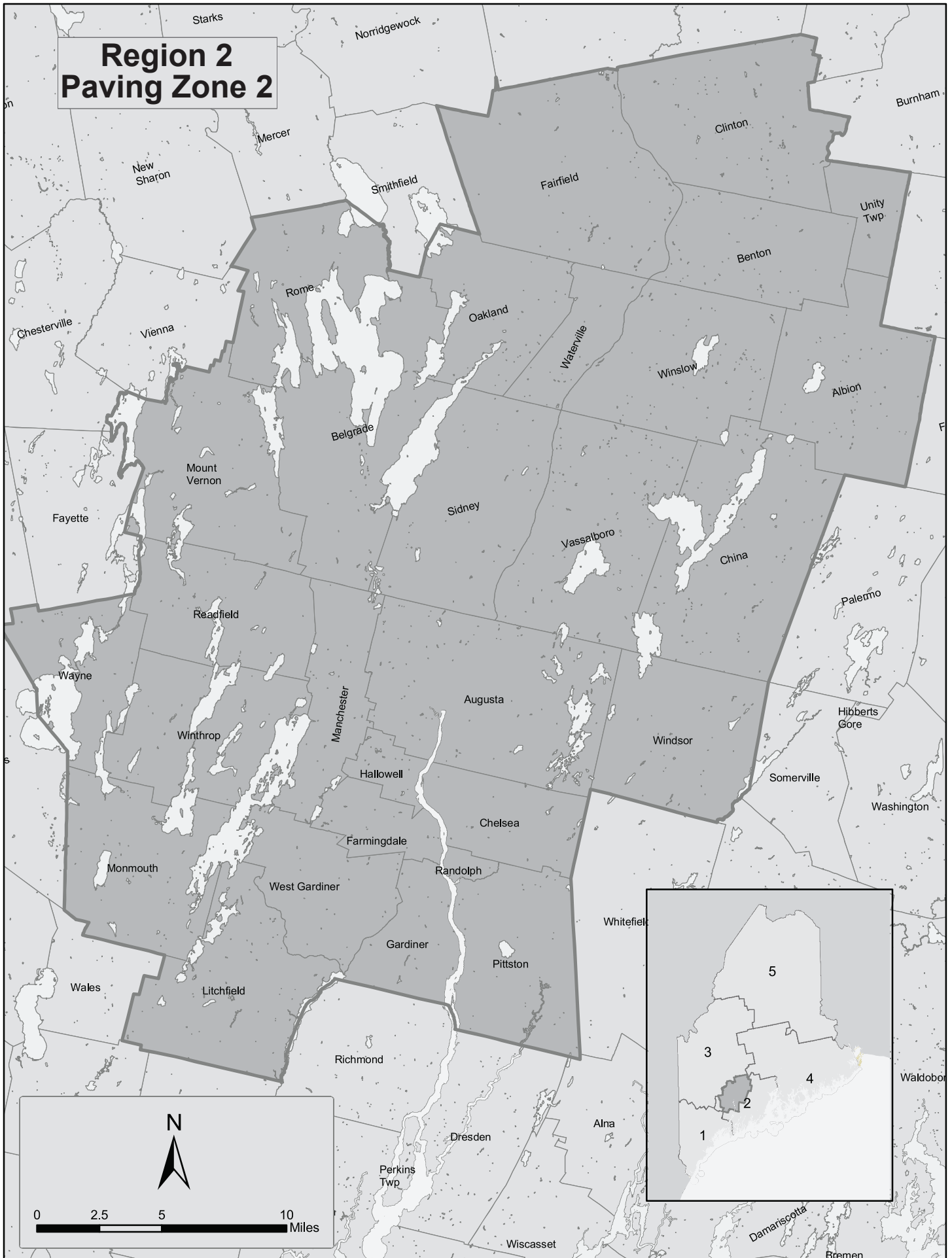

Region 2 Paving Zone 3

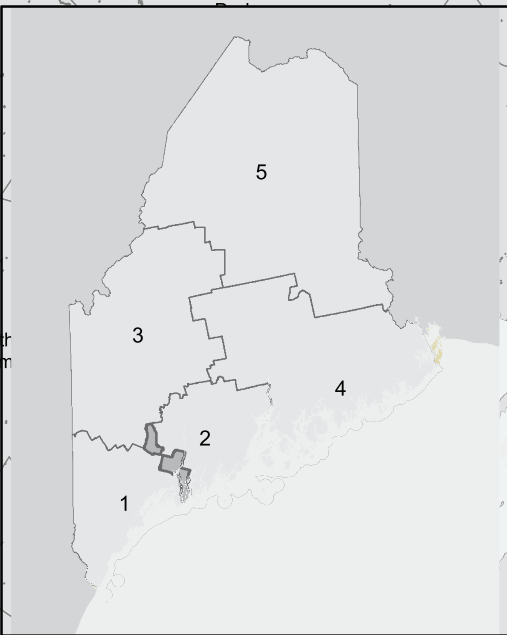
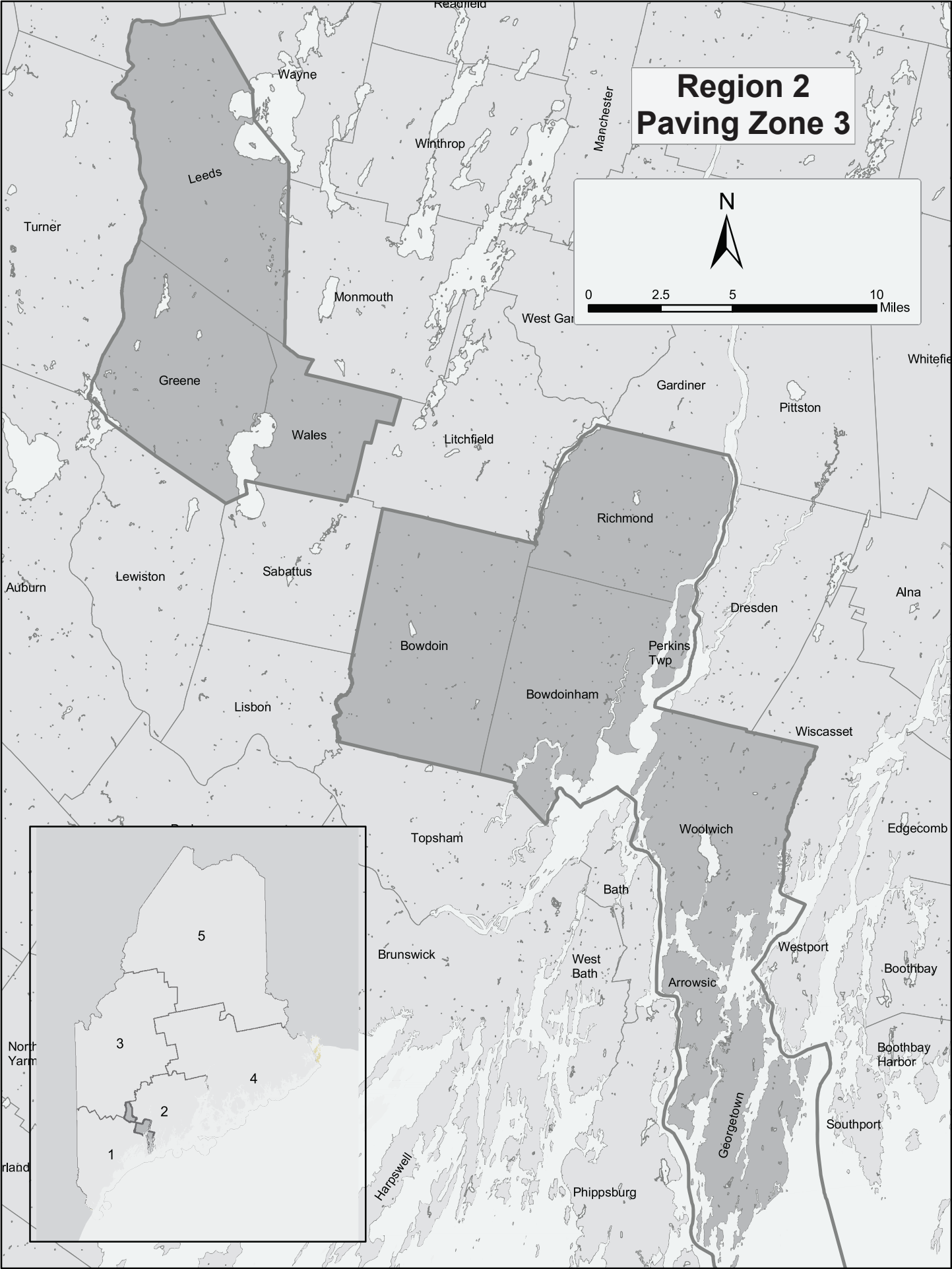
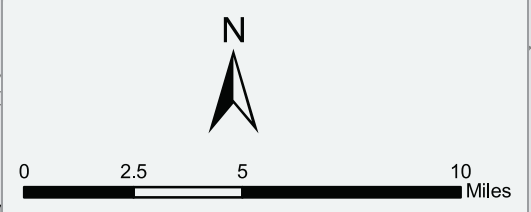

Region 2 Paving Zone 4

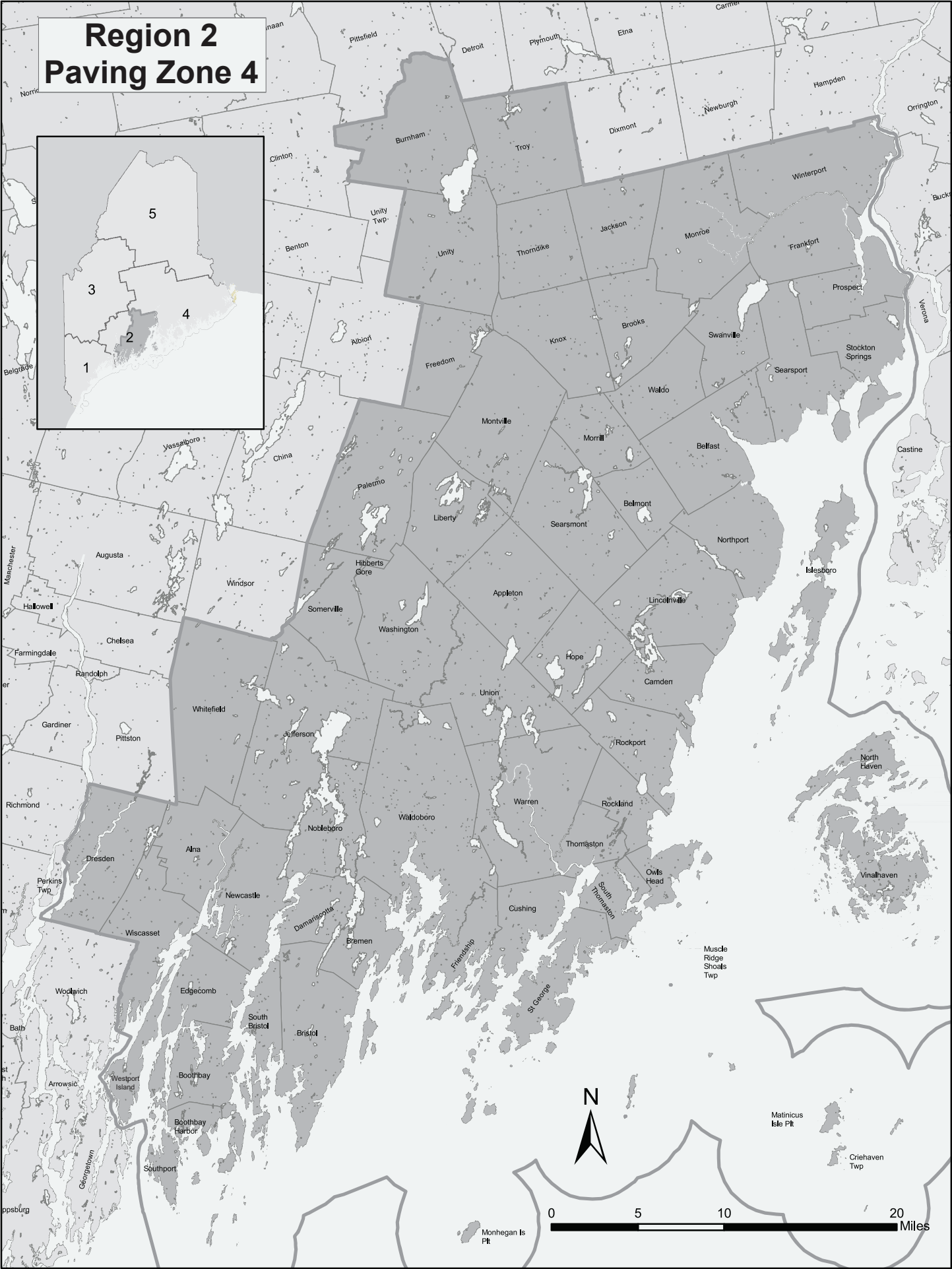
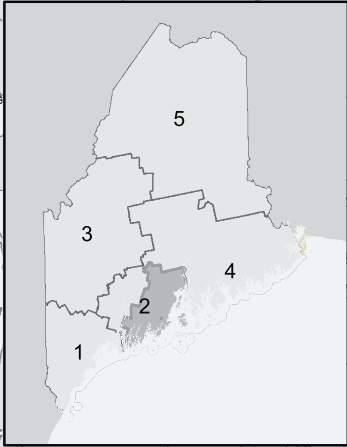

Region 3 Paving Zone 5

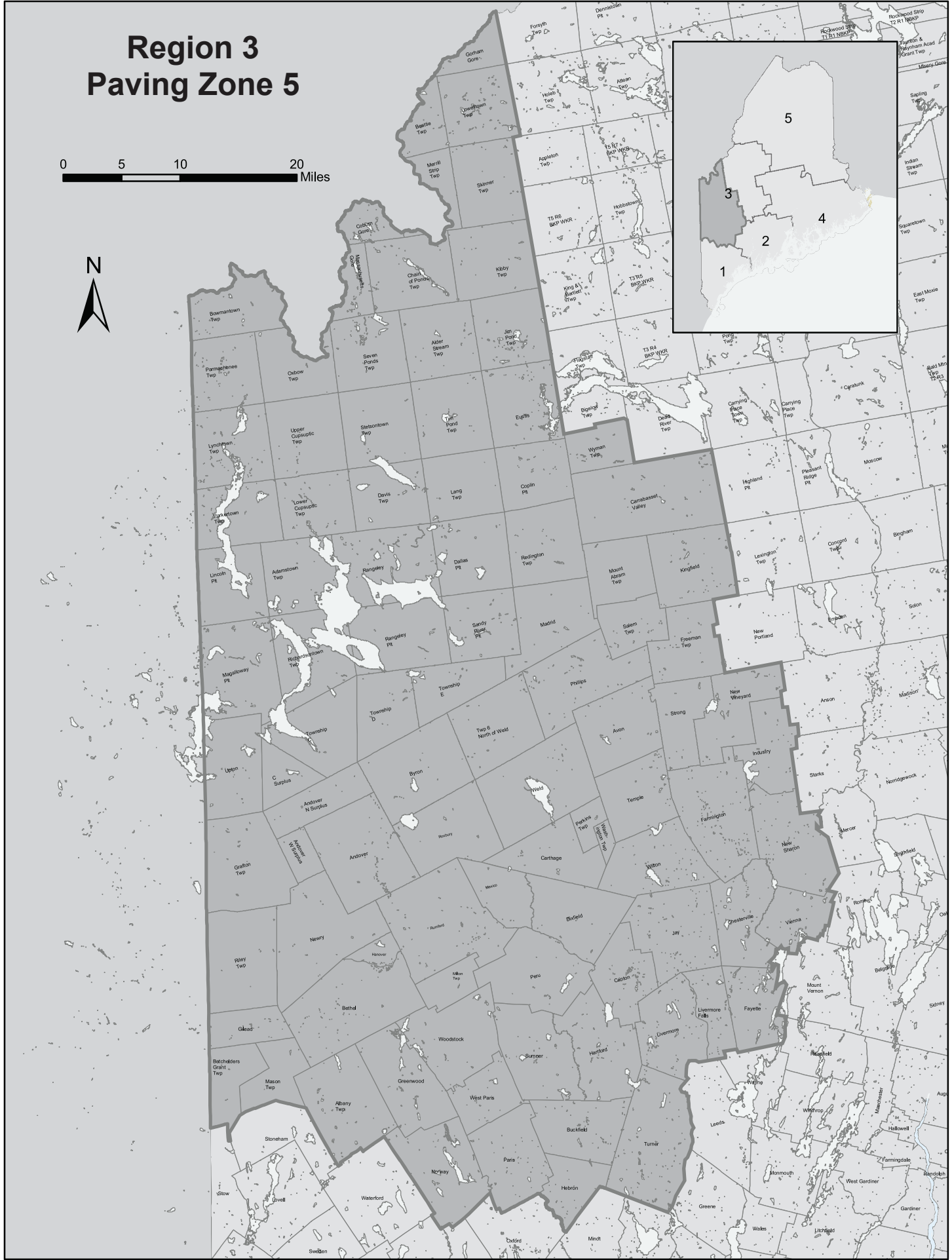
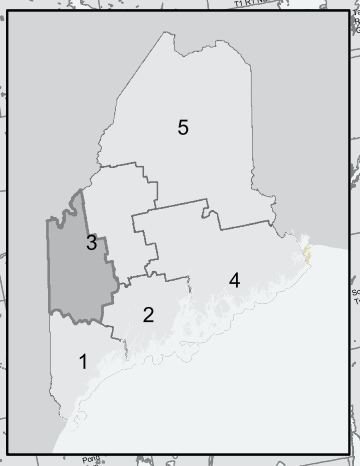

Region 3 Paving Zone 6

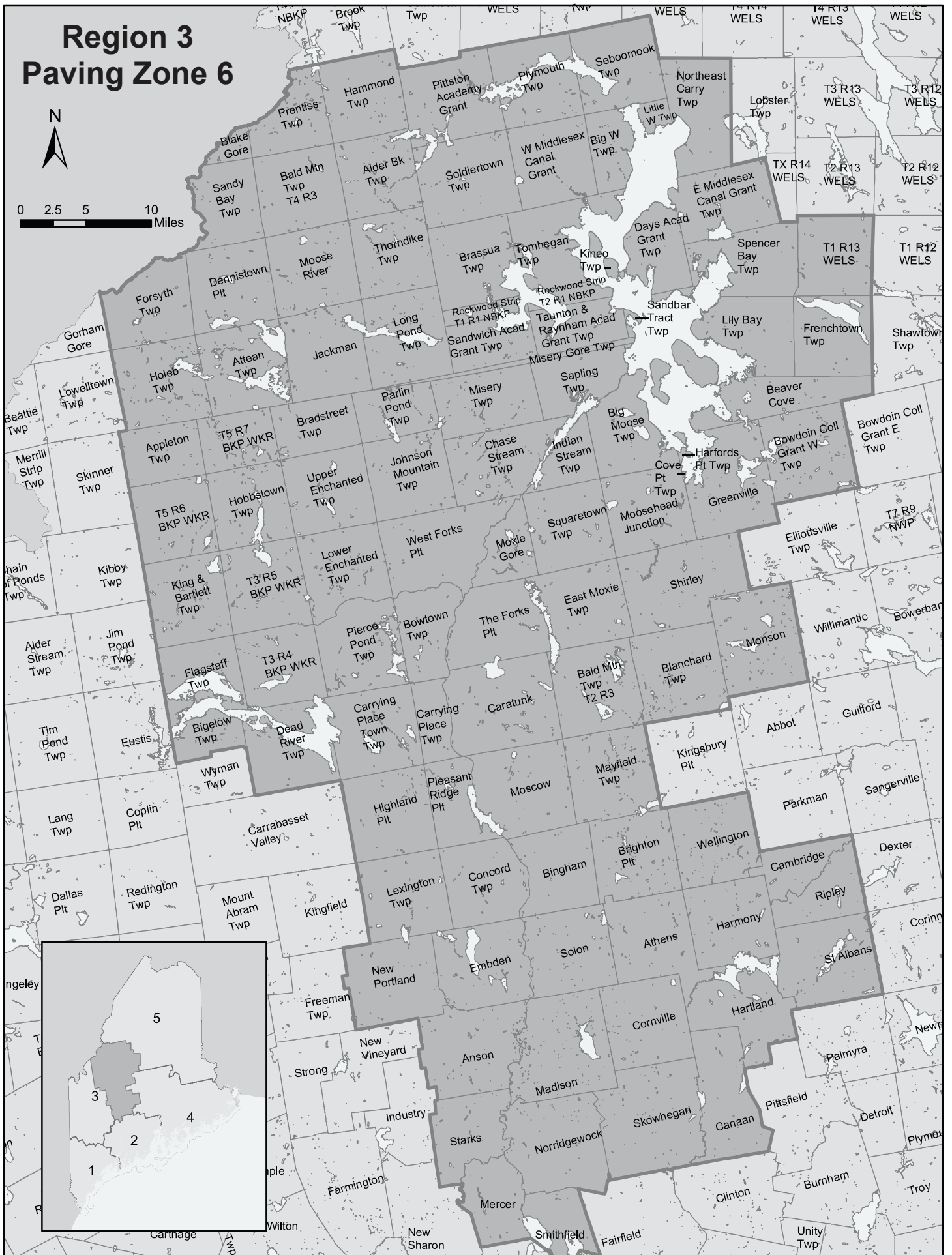

Region 4 Paving Zone 7

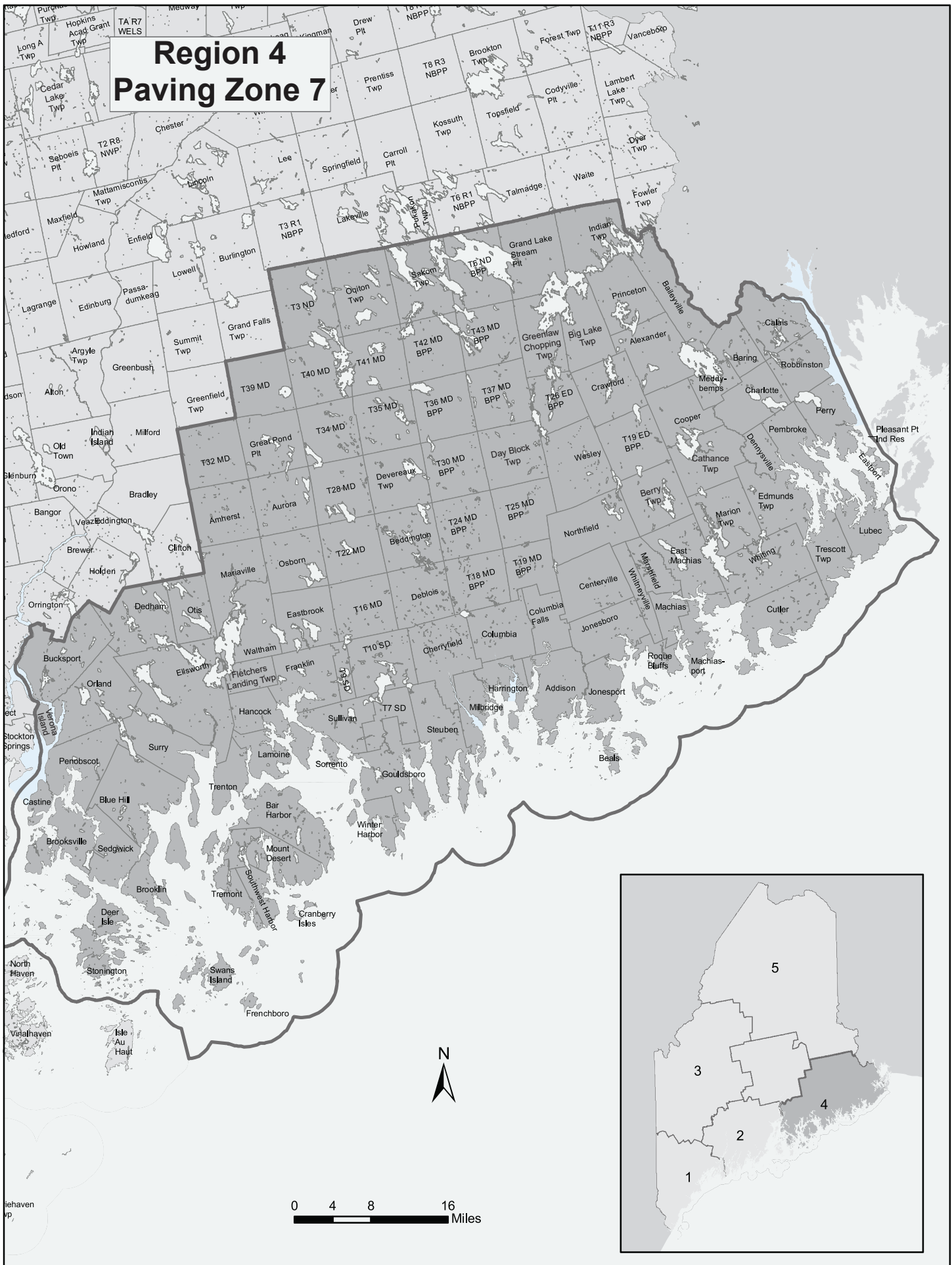

**Region 4
Paving Zone 8**

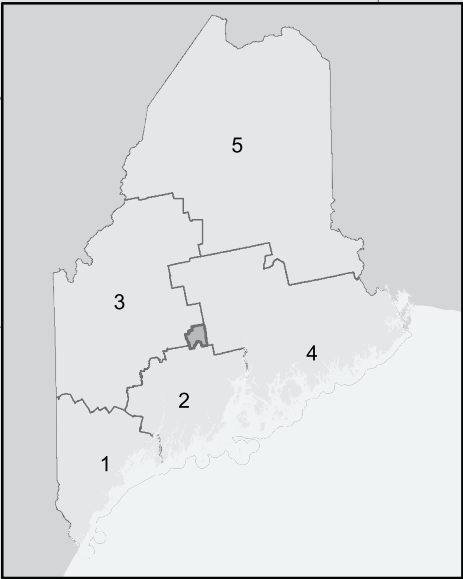
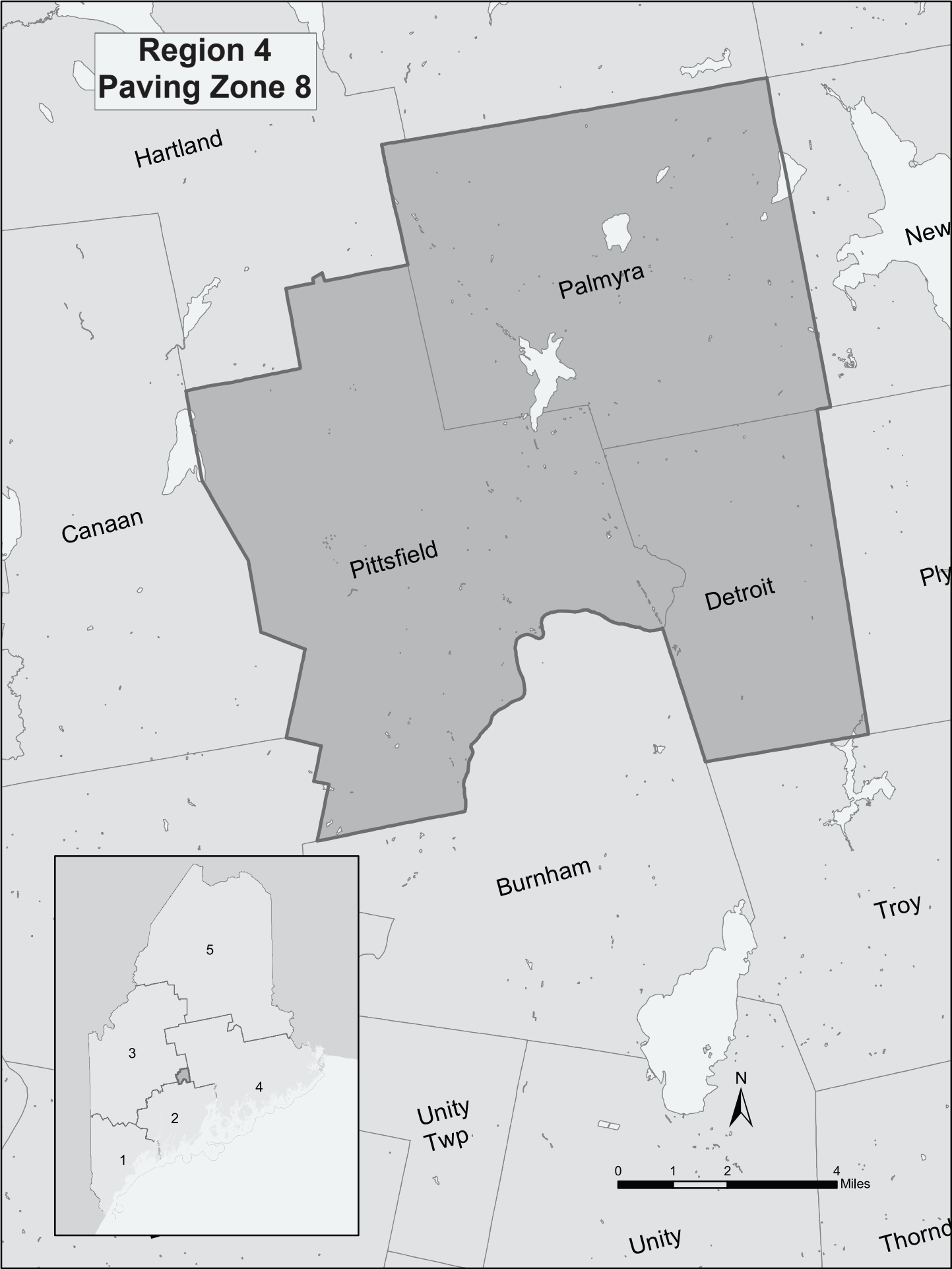

Region 5 Paving Zone 10

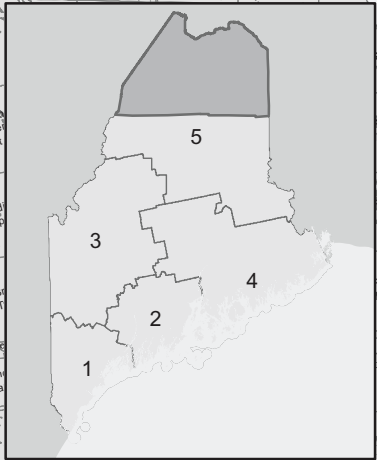
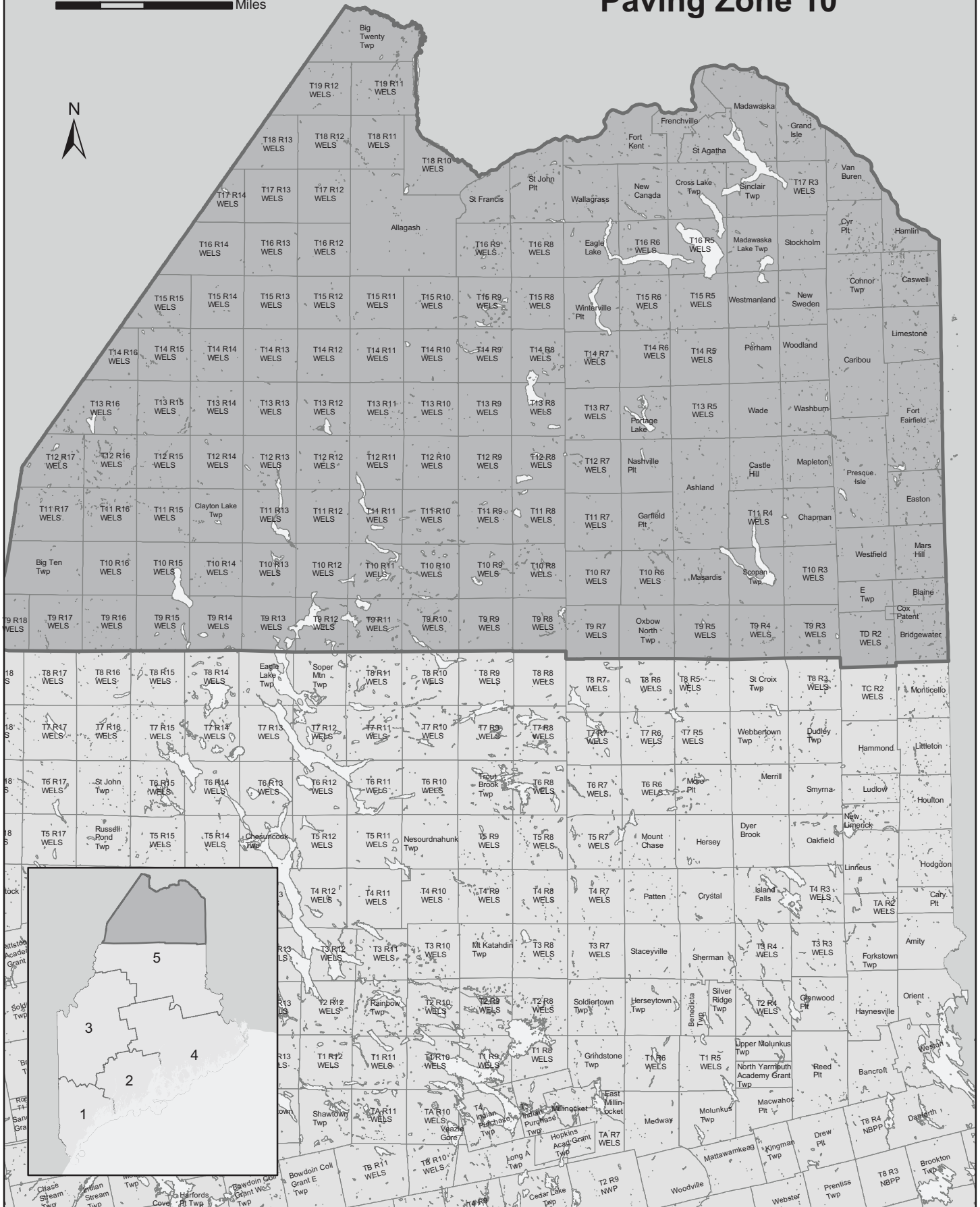

State of Maine
 Department of Labor
 Bureau of Labor Standards
 Augusta, Maine 04333-0045
 Telephone (207) 623-7906

Wage Determination - In accordance with 26 MRS §1301 et. seq., this is a determination by the Bureau of Labor Standards, of the fair minimum wage rate to be paid to laborers and workers employed on the below titled project.

**2022 Fair Minimum Wage Rates
 Highway & Earth Statewide**

Occupational Title	Minimum Wage	Minimum Benefit	Total
Carpenter	\$25.79	\$4.37	\$30.16
Cement Masons And Concrete Finisher	\$20.00	\$0.00	\$20.00
Commercial Divers	\$28.00	\$2.50	\$30.50
Construction And Maintenance Painters	\$23.34	\$2.53	\$25.87
Construction Laborer	\$21.50	\$0.37	\$21.87
Control And Valve Installers And Repairers - Except Mechanical Door	\$26.00	\$5.49	\$31.49
Conveyor Operators And Tenders	\$18.00	\$2.71	\$20.71
Crane And Tower Operators	\$31.54	\$6.68	\$38.22
Crushing Grinding And Polishing Machine Operators	\$21.00	\$4.52	\$25.52
Earth Drillers - Except Oil And Gas	\$23.25	\$5.53	\$28.78
Electricians	\$39.27	\$20.31	\$59.58
Excavating And Loading Machine And Dragline Operators	\$26.15	\$4.38	\$30.53
Fence Erectors	\$18.00	\$0.72	\$18.72
Flaggers	\$17.00	\$0.00	\$17.00
Heating And Air Conditioning And Refrigeration Mechanics And Installers	\$26.33	\$4.06	\$30.39
Heavy And Tractor - Trailer Truck Drivers	\$22.18	\$3.16	\$25.34
Highway Maintenance Workers	\$21.09	\$2.90	\$23.99
Industrial Machinery Mechanics	\$26.00	\$5.19	\$31.19
Industrial Truck And Tractor Operators	\$24.00	\$5.61	\$29.61
Light Truck Or Delivery Services Drivers	\$20.00	\$2.30	\$22.30
Millwrights	\$25.13	\$3.51	\$28.64
Mixing And Blending Machine Operators	\$24.71	\$8.59	\$33.30
Mobile Heavy Equipment Mechanics - Except Engines	\$25.00	\$3.37	\$28.37
Operating Engineers And Other Equipment Operators	\$30.90	\$2.74	\$33.64
Paving Surfacing And Tamping Equipment Operators	\$24.71	\$4.42	\$29.13
Pipelayers	\$28.00	\$7.20	\$35.20
Plumbers Pipe Fitters And Steamfitters	\$26.00	\$2.93	\$28.93
Reinforcing Iron And Rebar Workers	\$48.58	\$0.00	\$48.58
Structural Iron And Steel Workers	\$24.00	\$1.36	\$25.36

Welders are classified as the trade to which welding is incidental (e.g. welding structural steel is Structural Iron and Steel Worker)

Apprentices – The minimum wage rate for registered apprentices are those set forth in the standards and policies of the Maine State Apprenticeship and Training Council for approved apprenticeship programs.

For any other specific trade on this project not listed above, contact the Bureau of Labor Standards for further clarification.

Title 26 §1310 requires that a clearly legible statement of all fair minimum wage and benefits rates to be paid the several classes of laborers, workers and mechanics employed on the construction on the public work must be kept posted in a prominent and easily accessible place at the site by each contractor and subcontractor subject to sections 1304 to 1313.

Appeal – Any person affected by the determination of these rates may appeal to the Commissioner of Labor by filing a written notice with the Commissioner stating the specific grounds of the objection within ten (10) days from the filing of these rates.

A true copy

Attest: 
 Scott R. Cotnoir
 Wage & Hour Director
 Bureau of Labor Standards

Expiration Date: 12-31-2022

NOTICE TO CONTRACTORS - PREFERRED EMPLOYEES

Sec. 1303. Public Works; minimum wage

In the employment of laborers in the construction of public works, including state highways, by the State or by persons contracting for the construction, preference must first be given to citizens of the State who are qualified to perform the work to which the employment relates and, if they can not be obtained in sufficient numbers, then to citizens of the United States. Every contract for public works construction must contain a provision for employing citizens of this State or the United States. The hourly wage and benefit rate paid to laborers employed in the construction of public works, including state highways, may not be less than the fair minimum rate as determined in accordance with section 1308. Any contractor who knowingly and willfully violates this section is subject to a fine of not less than \$250 per employee violation. Each day that any contractor employs a laborer at less than the wage and benefit minimum stipulated in this section constitutes a separate violation of this section. [1997, c. 757, §1 (amd).]

SPECIAL PROVISION
SECTION 103
AWARD AND CONTRACTING
(Basis of Award)

Bids are requested from Contractors desiring to perform maintenance paving Work for some MaineDOT maintenance work zones and small construction work sites between contract execution and March 31, 2022.

A Bidder is not required to bid all Regions or zones and may bid on one or more zones(s). Bidders are not required to bid all items.

The dollar amount of this Contract does not guarantee that the Department will assign Work for any or all of the total amount.

The Department and each responsive bidder may enter into a Contract that will obligate each bidder to perform work pursuant to Assignment Letters at prices listed by the bidder in the Schedule of Items depending upon the needs of the Department and according to the following terms. Work will be assigned under these contracts according to the following process. The Department will estimate the Contractor with the lowest cost for the particular Work (the "Assignment") based on the unit prices bid for the total quantity of estimated work in that Assignment.

The Department will offer to assign the Work to the Contractor with the lowest estimated cost for the particular the Assignment, and that Contractor will have first option to perform the Work within the schedule specified in the offer of the Assignment. The Contractor shall have five business days to accept an Assignment unless otherwise stated in the offer to assign work. If the Department has determined that the Assignment is an emergency, the Contractor shall have one hour to respond. Contractors are not required to accept Assignments offered. If Contractors do not respond to requests for assignments in the allotted time, The Department shall proceed as if the Contractor has declined the assignment.

If this Contractor does not accept the Assignment, then the Department will contact the Contractor that is estimated to have the next lowest Assignment cost to see if that Contractor will accept the Assignment and subsequent Contractors in ascending order of the amount of their bids, until a Contractor accepts the Assignment.

Upon mutual agreement, an Assignment Letter stating the quantities and schedules will then be sent to the successful Contractor. The Work described in this letter will become part of the Contract.

If, a Contractor fails to work when required or performs it in an unsatisfactory manner, or fails to meet other contractual requirements, the Department may issue a written warning.

If the Contractor subsequently fails to work when required or performs it in an unsatisfactory manner, or fails to meet other contractual requirements, the Department reserves the right to immediately terminate the Contract by written Notice of Termination. In this event, the Department may complete the work with its own forces or enter into an Assignment with another entity for the completion of the work, or use such other methods as in the opinion of the Department are required for to complete the Assignment. If a party under an assignment letter contract with the Department continually refuses Assignment Letter work, their contract shall be subject to termination.

The accepted quantities will be paid for in accordance with Special Provisions. The dollar amount of this Contract does not guarantee that the Department will assign Work for any or all of the total amount. The regions in which bids are received and accepted and the following estimates will be used to determine the original contract amount. The following estimates are based on previously contracted expenditures.

Region 1 - \$50,000
Region 2 - \$150,000
Region 3 - \$200,000
Region 4 - \$20,000
Region 5 - \$100,000

Not all paving work will be done under these contracts. These Contracts will not include Work that falls under Work Plan or Program projects, and separately advertised projects. Work may also be done by the Department. Emergency Work may be done by other means not associated with this solicitation.

SPECIAL PROVISION
SECTION 104
GENERAL RIGHTS AND RESPONSIBILITIES
(Wage Rates)

104.3.8B State Wage Rates and Labor Laws The State Wage Rates enclosed apply to this work. Federal Wage Rates do not apply to this work.

SPECIAL PROVISION
SECTION 107
TIME
(Contract Time)

The Contract shall commence no sooner than April 1, 2022.

Work will be assigned under these contracts beginning after contract execution and continuing until March 31, 2023.

SPECIAL PROVISION
SECTION 107
TIME
(Project Closeout)

Delete the entire Section 107.9 Project Closeout and replace with the following:

107.9.4 Closeout Documentation. Upon receipt and approval of the itemized invoice submitted by the Contractor as specified in Special Provision Section 108, Payment, Invoices and Payment, the Assignment will be considered Physically Complete.

107.9.5 Final Acceptance. Within 30 days of the acceptance of the invoice, the Contractor shall provide the All Bills Paid Letter and Certified Payroll Reports confirming compliance to Section 104.3.8 Wage Rates and Labor Laws.

If the Contractor fails to resolve issues and deliver Closeout Documentation within the 30 Days provided in Section 107.9.5, the Department may provide a final notice informing the Contractor in writing that unless the Contractor Delivers all Closeout Documentation within 30 Days of the date of Receipt of final notice, the Contractor shall be in Default under the Contract. The Contractor may be refused the opportunity to accept the next assignment under the Contract. The Department may then pursue all remedies provided by the Contract or by law, including withholding payment on future assignments within the Contract. For a related provision, see Section 102.1.1 - Eligibility to Bid - Basic Requirements.

SPECIAL PROVISION
SECTION 108
PAYMENT
(Invoices and Payment)

The Contractor shall submit an itemized invoice to the Department for services monthly and at the completion of the Work or as otherwise noted in the Contract documents for approval and payment.

At a minimum, invoices shall be on a Contractor's letterhead and shall include the following information:

- Contractor name, address & Contract Number
- Invoice Date & Number
- Period during which Work was performed or Dates of Service
- Description and Location of Work or Service
- Quantities at the Prices contained in the Contractor's Bid
- Extra Work agreed to by written Contract Modification
- Total amount due

The Department will make payments based upon approved complete and correct invoices for accepted Work invoiced at bid prices. No such payment will be made if, in the judgment of the Department, the Work is not in accordance with the provisions of the Contract.

Payments to the Contractor shall be full compensation for furnishing all labor, equipment, materials, services, and incidentals used to perform all Work under the Contract in a complete and acceptable manner, and for all risk, loss, damage, or expense of any kind arising from the nature or execution of the Work. The Contractor shall pay all taxes, charges, fees, and allowances. Except as expressly provided otherwise in this Contract, all such taxes, charges, fees, and allowances are Incidental to the Contract. Most items are exempt from Maine sales tax. The Contractor shall Bid in accordance with the Maine statutory exemption from sales tax. No payments due the Contractor will be adjusted for inflation. No interest shall be due and payable on any payment due the Contractor. The Department may require that the Contractor submit backup documentation including copies of receipts, invoices, and itemized payments to Subcontractors.

The Department may withhold payments claimed by the Contractor on account of:

- A. Incomplete, Inaccurate or Incorrect Invoices,
- B. Defective Work or non-conforming Work,
- C. Damages for Non-conforming, Defective or Unauthorized Work or Equipment,
- D. Damage to a third party,
- E. Claims filed or reasonable evidence indicating probable filing of claims,
- F. Failure of the Contractor to make payments to Subcontractors or for Materials or labor,

- G. Regulatory non-compliance or enforcement,
- H. Failure to submit Documentation
- I. Repetitive breakdowns
- J. All other causes that the Department reasonably determines negatively affect the State's interest.

The Department may hold, temporarily or permanently, retainage as needed to assure timely Completion of the Work and payment of all Subcontractors and Suppliers in Conformity with the Contract.

The Acceptance by the Contractor of the final payment, as evidenced by cashing of the final payment check, constitutes a release to the Department from all claims and liability under the Contract. Upon Final Acceptance, the Contractor is released from further obligation, except for warranty obligations provided for in this Contract.

**SPECIAL PROVISION
(PAVING TRAINS)**

This work shall consist of providing all equipment and personnel to place and compact Hot Mix Asphalt Pavement or Plant Mix Recycled Asphalt Pavement (PMRAP) as directed. The equipment shall be of sufficient size and in good operating condition.

Class I Paving Train One paver with a 10-foot activated heated main screed with activated extensions. The paver shall be equipped with automatic grade and slope controls. The paver shall conform to Standard Specifications 401.09 Pavers. Two 10-ton steel rollers with at least one being vibratory shall be required. One pneumatic tire roller weighing at least 16 ton shall be required. All rollers shall conform to Standard Specifications 401.10 Rollers.

Class II Paving Train One paver with a minimum 8-foot activated heated main screed with activated extensions. The paver shall be equipped with automatic grade and slope controls. The paver shall conform to Standard Specifications 401.09 Pavers. Two 10-ton steel rollers with at least one being vibratory shall be required. One pneumatic tire roller weighing at least 10 ton shall be required. All rollers shall conform to Standard Specifications 401.10 Rollers.

Class III Paving Train One paver with a minimum 8 foot activated heated main screed with activated extensions. One 10-ton vibratory steel roller conforming to Standard Specifications 401.10 Rollers shall be required.

Class IV Paving Train One paver with a minimum 40 inch activated heated main screed with activated extensions. One 10-ton vibratory steel roller conforming to Standard Specifications 401.10 Rollers shall be required.

Class V Hand Crew One dual axle gated wheeler capable of hauling 12 tons or greater. One 3-5 ton vibratory steel roller conforming to Standard Specifications 401.10 Rollers shall be required. The minimum crew shall include one raker, two laborers, a working supervisor, a roller operator and a truck driver.

Method of Measurement: Paving Train and Hand Crew, will be measured by the hour to the nearest ½ hour.

Prior to assigning work, the Department and the Contractor shall mutually agree to the assignment location(s), dates, time, duration, and criteria establishing payment hours.

Hourly work will be measured for payment in accordance with the criteria for payment hours established at the time the Contractor accepted the assignment and the contract.

SPECIAL PROVISION (PAVING TRAINS)

This criteria for the hour at which payment begins could include:

- the scheduled show up time,
- the time the Contractor was on site and ready to work,
- the time physical work under this contract commenced,
- or other such time determined by the Department.

This criteria for the hour at which payment ends could include:

- the scheduled time,
- the time when work under this contract was done for the day,
- or other such time determined by the Department.

Hours to be measured for payment will be determined by the Department.

At the Departments discretion, the Contractor may be paid for hours spent in requested standby, for hours not worked during a scheduled day due to delays and schedule changes caused by the Department, and other circumstances for which the Contractor may be due compensation.

Equipment down time resulting from equipment failure will not be measurable for payment and not be included in payments for the day's work. The number of work hours will be reduced to exclude the down time. The minimum reduction shall be one-half hour.

Supervision required for the successful performance of hourly work will not be measured for payment but shall be considered incidental to the contract. This does not relieve the Contractor of the responsibility of supervising and coordinating the work.

Basis of Payment: The accepted quantity of Paving Train and Hand Crew shall be paid for at the contract unit price per hour. Payment shall include supplying all equipment, operators, hand tools, personnel, water/service truck, fuel, grease, equipment maintenance and all other incidentals necessary to operate the equipment to successfully complete the work.

**SPECIAL PROVISION
(SKID STEERS AND TRUCKS)**

This work consists of furnishing and operating equipment in conjunction with placing Hot Mix Asphalt Pavement or Plant Mix Recycled Asphalt Pavement (PMRAP) when required by the MaineDOT. The equipment shall be of sufficient size and in good operating condition.

The Contractor shall be responsible for all fuel, grease, oil, maintenance, servicing, operation, protection required for their equipment, in addition to mobilization and all other incidentals. Contractor shall provide for the required vehicle insurance, registration and licensing of any equipment used to perform the services herein.

Skid Steer (including operator) Front end scoop mounted on crawler or pneumatic tires. Minimum size of 46hp with a 10cf heaped capacity bucket. To be provided when directed by MaineDOT.

Truck – Large (including operator) Dump body with a rated capacity on pneumatic tires. Dump shall be manufacturer rated at eight (8) cy or greater. To be provided when required by MaineDOT.

Method of Measurement: Skid Steer and Truck will be measured by the hour to the nearest ½ hour. Supervision required for the successful performance of hourly work will not be measured for payment but shall be considered incidental to the contract. This does not relieve the contractor of the responsibility of supervising and coordinating the work.

Basis of Payment: The accepted quantity of Skid Steer and Truck shall be paid for at the contract unit price per hour. Payment shall include supplying all equipment, operators, personnel, fuel, grease, equipment maintenance and all other incidentals necessary to operate the equipment to successfully complete the work.

Payment will be made under:

<u>Pay Item</u>		<u>Pay Unit</u>
631.133	Skid Steer (including operator)	Hour
631.172	Truck – Large (including operator)	Hour

**SPECIAL PROVISION
(MOBILIZATION)**

NOTE: The Contractor and Department shall agree upon the type of Mobilization prior to beginning any work assignment.

Mobilization - Hourly

The Contractor shall be paid for mobilization by the hour for each day they perform Work for the Department with a Class I, II, or III paving train or a Class IV hand crew, skid steer or curb where the crew is not in overnight status. The contractor will be paid by the hour for the time it takes to travel to and from the work site. The hours will be measured from the company's closest base of operations to the project site. The total number of hours will be rounded off to the nearest ½ hour. This may involve work at multiple sites within the specified area on the same day. The Contractor shall be paid for mobilization by the hour for time they travel to or from the project site. All of the Equipment specified in the Assignment Letter and Contract must be on site within one hour of the scheduled time and accepted in order for mobilization to be paid for that day.

Mobilization - Overnight

The Contractor shall be paid one calendar day of mobilization for each day they perform Work for the Department with Class I, II, or III paving trains where the work requires more than one day to complete and requires the crew to spend the night away from home. This may involve work at multiple sites within the specified area on the same day. All travel time will be paid for with the hourly mobilization Item 659.11. All of the Equipment specified in the Assignment Letter and Contract must be on site within one hour of the scheduled time and accepted in order for mobilization to be paid for that day.

Mobilization - Night Time

In addition to 659.11 Mobilization - Hourly and/or 659.12 Mobilization – Overnight, the Contractor shall be paid for one calendar day of night time mobilization for each night they provide services to the Maine DOT for paving services when the work or any portion thereof is conducted between sunset and ½ hour before sunrise according to the Sunrise/Sunset Table at <http://www.sunrisesunset.com/usa/Maine>. If the project town is not listed, the closest town on the list will be used as agreed.

Pay Item

659.11 Mobilization - Hourly
659.12 Mobilization - Overnight
659.13 Mobilization – Night Work

Pay Unit

Hour
Calendar Day
Calendar Day

**SPECIAL PROVISION
(BITUMINOUS TACK COAT)**

This work consists of furnishing and applying one uniform application of liquid bituminous material on an approved surface in accordance with these specifications. The bituminous material shall meet the applicable requirements of Standard Specification, Section 702 - Bituminous Materials. The Contractor shall provide RS-1 or HMFS-1 emulsified asphalt and a distributor truck that conforms to Standard Specifications 409.05 to apply the emulsified asphalt. Bituminous material shall be applied by a pressure distributor in a uniform, continuous spread over the area to be treated. The Contractor will be paid by the hour for the distributor truck and by the gallon for the emulsified asphalt.

Method of Measurement: The Distributor Truck will be measured by the hour to the nearest ½ hour when working on the project site. Supervision required for the successful performance of hourly work will not be measured for payment but shall be considered incidental to the contract. This does not relieve the Contractor of the responsibility of supervising and coordinating the work. Emulsified Asphalt (Tack) will be measured to the nearest gallon.

Basis of Payment: The accepted quantity of Distributor Truck shall be paid for at the contract unit price per hour. Payment shall include supplying all equipment, an operator, fuel, grease, equipment maintenance and all other incidentals necessary to operate the equipment to successfully complete the work.

The accepted quantity of Emulsified Asphalt (Tack) shall be paid for at the contract unit price per gallon. Payment shall include the delivery of Emulsified Asphalt (Tack) to the project site.

<u>Pay Item</u>	<u>Pay Unit</u>
409.15 Bituminous Tack Coat	Gallon
Distributor	Hour

SPECIAL PROVISION
PAVEMENT GRINDING
(Butt Joints)

This work shall consist of providing all the equipment and personnel required to remove existing bituminous asphalt pavement to create a butt joint and/or around structures. Existing pavement shall be removed to a depth of between 1 inch and 3 inches depending on the depth of new pavement to be placed.

The Department will be responsible for all work area signs, traffic control, and hauling of all pavement grindings.

Method of Measurement: Removal of existing bituminous asphalt pavement by grinding will be measured by the square yard.

Basis of Payment: Removal of existing bituminous asphalt pavement by grinding will be paid for at the contract unit price for the number of square yards removed as directed which will be full compensation for providing all equipment and labor necessary to remove the existing bituminous asphalt pavement and for loading it into trucks. No separate payment will be made for Mobilization.

Payment will be made under:

<u>Pay Item</u>	<u>Pay Unit</u>
Butt Joints (less than 250 SY)	Square Yards
Butt Joints (greater than or equal to 250 SY)	Square Yards

SPECIAL PROVISION
(BITUMINOUS CURB)

This work shall consist of providing all equipment and personnel to install Bituminous Curb. The equipment shall be in good operating condition.

Preparation of Base Before placing curb, the foundation course shall be thoroughly cleaned of all foreign and objectionable material. String or chalk lines shall be positioned on the prepared base to provide guide lines. The foundation shall be uniformly painted with tack coat at a rate of 0.04 to 0.14 gal/yd².

Placing The curb shall be placed by an approved power operated extruding type machine using the shape mold called for, mold 1, mold 2, or mold 3 as shown in Supplemental Standard Detail 609(03). A tight bond shall be obtained between the base and the curb. MaineDOT may permit the placing of curb by other than mechanical curb placing machine when short sections or sections with short radii are required. The resulting curbing shall conform in all respects to the curbing produced by the machine.

Acceptance Curb may be accepted or rejected based on appearance concerning texture, alignment, or both. All damaged curb shall be removed and replaced at the contractor's expense.

Polyester fibers Polyester fibers shall be uniformly incorporated into the dry mix at a rate of 0.25 percent of the total batch weight.

Method of Measurement Bituminous Curb will be measured by the linear foot along the front face of the curb at the elevation of the finished pavement, complete in place and accepted. Supervision required for the successful performance of the work shall be considered incidental to the contract. This does not relieve the contractor of the responsibility of supervising and coordinating the work.

Basis of Payment The accepted quantity of Bituminous curbing shall be paid for at the contract unit price per linear foot. Payment shall include supplying all bituminous curb mix, equipment, operators, hand tools, personnel, service truck, fuel, grease, equipment maintenance and all other incidentals necessary to operate the equipment to successfully complete the work. There will be no separate payment for tack coat or cutting and shaping terminal ends, but these will be considered included in the work of the curb installation.

Payment will be made under:

<u>Pay Item</u>	<u>Pay Unit</u>
609.31 Bituminous Curb	Linear Foot

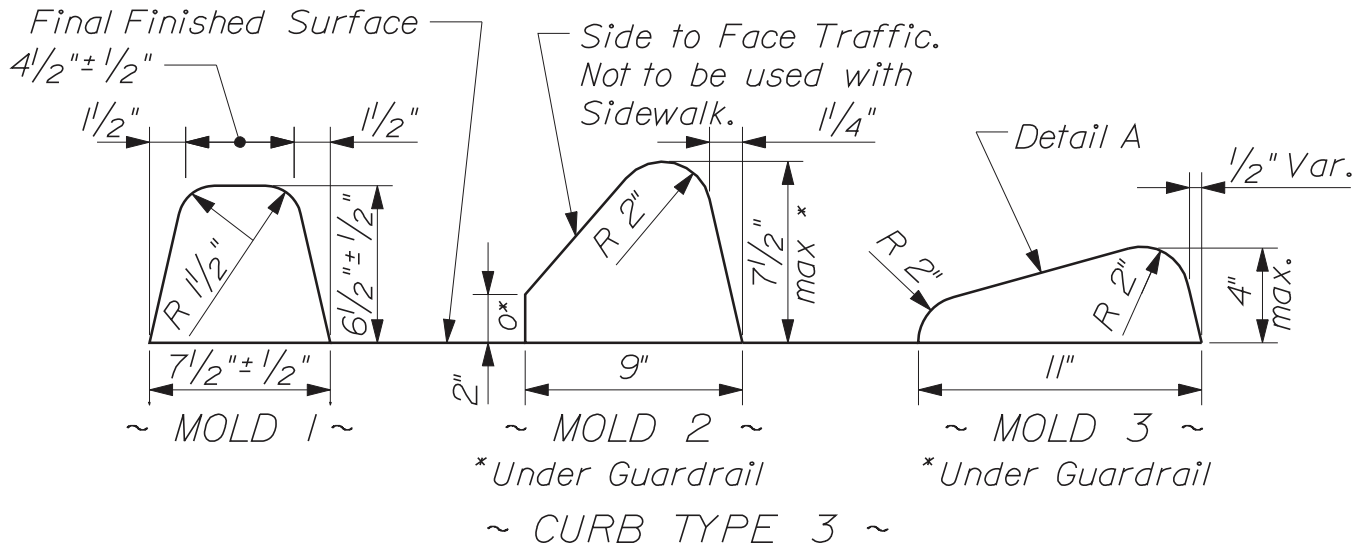
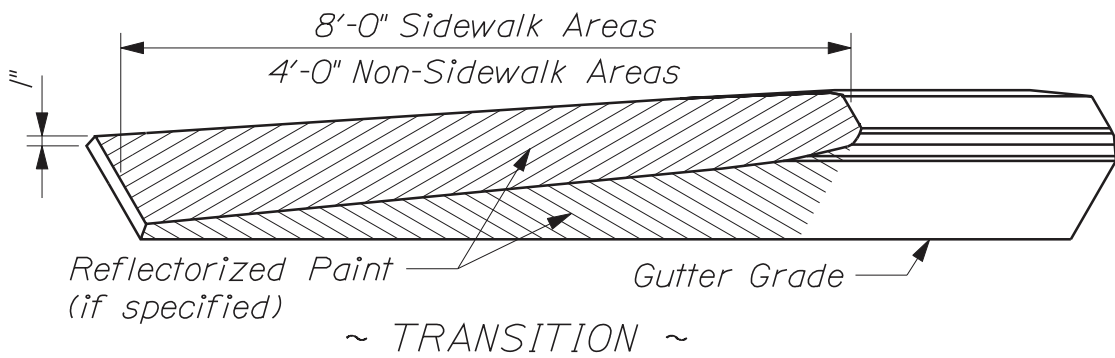

Curb Mold 2 or 3 shall be used in all situations except for where the curb forms the edge of the sidewalk. Mold 1 shall be used in conjunction with sidewalks or where there is a potential for sidewalks. Mold 3 shall be used in situations where the design speed exceeds 45 mph. Maximum height of Curb under Guardrail shall not exceed 4".

~ DETAIL A ~

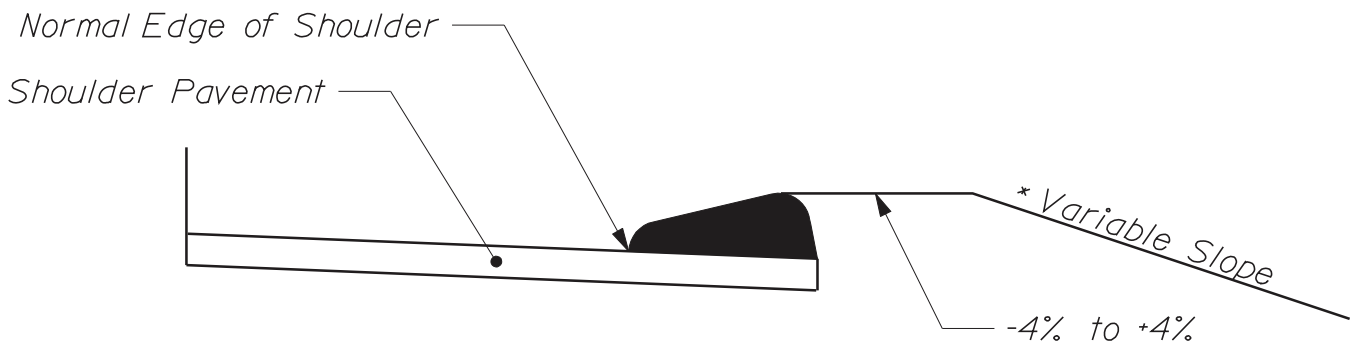

* See Typical Sections for Project

CURB TYPE 3
609(03)

SPECIAL PROVISIONS
ADDITIONS AND REVISIONS TO STANDARD SPECIFICATIONS
DIVISION 100

SPECIAL PROVISION SECTION 101
CONTRACT INTERPRETATION

101.2 Definitions Add the following:

“MaineDOT The Department of Transportation of the State of Maine, as established by 23 MRSA §4205 et seq. for the administration of Highway, Bridge, and other public Works; acting through the Commissioner and his/her duly authorized representatives.”

101.2 Definitions Apparent Successful Bidder Delete the section in its entirety and replace with the following:

“All Bidders with the responsive responsible Bids as determined by the Department. A responsive responsible Bidder, that is Awarded the Contract. The Department may not execute the Contract with the Apparent Successful Bidders if a) the Apparent Successful Bidder fails to comply with all applicable pre-Award conditions or other pre-execution requirements of the Contract or b) if the Department chooses not to Award a Contract.”

101.2 Definitions Add the following:

“Contract Agreement form The Contract Agreement, Offer and Award, the Maine Department of Transportation Contract Agreement Transportation Related Maintenance Work, the Maine Department of Transportation Contract Agreement to Purchase Supplies, Materials and/or Equipment for a Specific Project, Contract Agreement to Purchase Materials and/or Equipment for a Project and Related Work, the Maine Department of Transportation Private Equipment Rental Agreement – with an Operator, the Maine Department of Transportation Private Equipment Rental Agreement – without an Operator, or other contract agreement contained in the bid documents.”

101.2 Definitions Successful Bidder Delete the section in its entirety and replace with the following:

“All responsive, responsible bidders to whom the Department intends to award the Contract. This status is evidenced by a “Notice of Intent to Award” Letter sent to the Successful Bidders.”

SPECIAL PROVISION SECTION 102
BIDDING

102.6 Bid Guaranty Delete the entire section 102.6.

102.7.1 Location and Time Delete the entire section and replace with the following:

“The Bidder must Deliver its Bid and Bid Guaranty in a sealed envelope to the exact location and before the precise time (as determined by the Department) specified in the Notice to Contractors or any applicable Bid Amendment. The sealed envelope must be labeled with the Bidder's name, the Work location, Title, and the words “Bid Enclosed”. As a minimum, the Bidder will submit a Bid Package consisting of the Notice to Contractors, the completed Acknowledgement of Bid Amendments form, the completed Schedule of Items, 2 copies of the completed Contract form, and any other Certifications or Bid Requirements listed in the Bid Book. For a related provision, see Section 102.11 - "Bid Responsiveness".

102.9 Bid Opening Delete the section in its entirety and replace with the following:

“Bids will be opened and publicly read at the time and place specified in the Notice to Contractors or any applicable Bid Amendments. The Department will read only the names of the Bidders. No other information will be made available prior to evaluation and award notification. Unit and lump sum prices are available for inspection by the Bidders immediately after Award. All Bids shall be sequestered until notification of award by the contracting agency after which time they become public record.

If, after the scheduled opening, the Department determines that there is not sufficient coverage of On-Call Services of the entire area being bid on, the Department may schedule a second bid opening date which extends the advertisement period of this Contract. Contractors will be notified of the new opening date by the normal Bid Amendment process. If the Bid Opening date is extended, any Bidders that have previously submitted Bids may choose **to** revise or **not to** revise their Bids. If the Bidder chooses to revise their Bid, they must resubmit a complete Bid Package which shall include a Bid and all other documents required in the Bid Documents and the original Bid will be returned to the Bidder. The Bid Package with the latest (newest) date shall replace all previously submitted packages.

The public reading of a Bid does not constitute a determination by the Department of whether the Bid is responsive or of whether the Bidder is responsible, though the Department may refuse to read Bids that are obviously non-responsive. Accordingly, the Department may reject a Bid as non-responsive and/or determine a Bidder is not responsible or ineligible to Bid even if that Bidder’s Bid is read at Bid Opening.”

102.11.1 Non-curable Bid Defects Revise the item on the list of non-curable Bid Defects for which the Department will reject Bids as non-responsive that reads “The Bid is not signed by a duly authorized representative of the Bidder.” by replacing it with the following:

“The Bid is not signed by a duly authorized representative of the Bidder.

- Properly submitted electronic bids meet this requirement.
- Paper bids must include either (1) one or more signed copies of the Contract Agreement form or (2) a signed copy of the Schedule of Items.”

102.11.2 Curable Bid Defects Revise the section by replacing it with the following:

“Unless the Department waives a curable Bid defect, the Bidder must cure, within the time stated in the written notice by the Department, but not less than 24 hours, all other Bid Defects not listed in Section 102.11.1 - Non-curable Bid Defects that are identified by the Department. Failure to cure such Defects within said time may result in forfeiture of the Bidder’s Bid Guaranty. Upon such failure, the Department may take any action in the best interests of the Department, including those set forth in Section 103.6 - Failure to Fulfill Award Conditions.

Such curable Bid Defects include, but are not limited to, the following.

The Bidder signs only one of the Contract Agreement Offer & Award forms.

Missing total sum of the items provided in the Schedule of Items.

The prices or signatures on the Bid or Bid Guaranty are not in ink or other non-erasable substance.

Failure to acknowledge Receipt and consideration of all Bid Amendments.

The Bid includes only one signed Contract Agreement form.

The Bid does not include a signed Contract Agreement form but does include a signed Schedule of Items.

If a submitted bid contains any additional conditions or alternate bidding language, the Bidder may cure the defect by removing all conditions and alternate language or the Department will reject the bid as non-responsive.

All other Defects that do not create a significant question as to the Bidder’s total Bid amount or the Bidder’s ability to complete the Work within the Contract Time or by the Contract Completion Date as determined by the Department.”

SPECIAL PROVISION SECTION 103
AWARD AND CONTRACTING

103.4 Notice of Award Delete the section in its entirety and replace with the following:

“The Department has 30 Days following Bid Opening to Deliver a written Notice of Intent to Award and request a payment bond, performance bond, insurance bond, special certifications, and other information from the Apparent Successful Bidders. If prequalification is required and an Apparent Successful Bidder is not prequalified at the time of Bid Opening, the Department shall have 15 days from the successful completion of the Prequalification process or 30 days following Bid Opening; whichever is longer. Once these pre-execution conditions are met, the Department will execute the Contract and notify the Contractor of the award with a written Notice of Award. If a Notice of Award is not sent within 30 days of receipt of the proper bonds, insurance, and other pre-award requirements, an Apparent Successful Bidder may withdraw its Bid without forfeiture of its Bid Guaranty or Bidding eligibility. The Notice of Intent to Award will set forth and/or reference the conditions that the Bidder must fulfill before Contract Execution. If the Department and an Apparent Successful Bidder agree, an extension beyond the 30 days of the Bid and Bid prices may occur and the Bid remains viable. For a related provision, see Section 103.5.”

103.5 Award Conditions Replace the first paragraph with the following:

“The Apparent Successful Bidder must provide and/or perform all of the items listed in this Section 103.5 within 14 Days of Receipt of the Notice of Intent to Award. Unless indicated otherwise, all items must be Delivered to the Department’s Bureau of Maintenance & Operations.”

103.5.1 Performance and Payment Bonds Delete the entire section 103.5.1.

103.5.4 Execution of Contract By Bidder Delete the entire section and replace with the following:

“The properly completed and signed Contract form provided with the Bid constitutes the Bidder’s offer. Once the Department has received the insurance, and any other pre-award items required, the Department will sign and execute the Contract. The point of Contract execution is when the Contractor receives written notice that the contract has been signed by the Department and executed.”

SPECIAL PROVISION SECTION 104
GENERAL RIGHTS AND RESPONSIBILITIES

104.3.8A. Federal Wage Rates and Labor Laws Delete the entire section 104.3.8A. Federal Wage Rates do not apply to this work.

104.3.8B State Wage Rates and Labor Laws The State Wage Rates enclosed apply to this work. Federal Wage Rates do not apply to this work.

104.4.3 Progress Meetings Delete the entire section 104.4.3.

SPECIAL PROVISION SECTION 105
GENERAL SCOPE OF WORK

105.2.2 Health and Safety Plan Delete the entire section and replace with the following:

“The Contractor has the authority and responsibility to ensure compliance with all applicable federal, State, and local laws governing safety, health, and sanitation including all applicable laws and regulations of OSHA. The Contractor shall comply with these laws and regulations and ensure compliance by its subcontractors.

The Contractor shall provide all safeguards, safety devices, and protective Equipment and take all other action that is necessary to continuously and effectively protect the safety and health of all persons from hazards related to the Work.”

105.3 Traffic Control and Management Delete the entire section and replace with the following:

“The Department will provide traffic control.”

105.8.1 Temporary Soil Erosion and Water Pollution Control Delete the entire section and replace with the following:

“The Department will provide soil erosion and water pollution control.”

SPECIAL PROVISION SECTION 107
TIME

Delete the entire section 107.4 (or the entire section 107) and replace with the following:

“107.4.1 General Duty of Contractor The Contractor is solely responsible for the planning and execution of Work in order to complete the Work within the Contract Time.”

SPECIAL PROVISION SECTION 110
INDEMNIFICATION, BONDING AND INSURANCE

110.3.2 Commercial General Liability Change the first sentence from: “...commercial general liability insurance in an amount not less than \$1,000,000.00 per occurrence and \$2,000,000.00 in the Aggregate” to “commercial general liability insurance in an amount not less than \$400,000.00 per occurrence and \$2,000,000.00 in the Aggregate”.

110.3.3 Automobile Liability Change the second sentence from: “... minimum limit of liability under this section shall be \$1,000,000.00 per occurrence” to “...minimum limit of liability under this section shall be \$400,000.00 per occurrence”.

2020 STANDARD DETAIL UPDATES

Standard Details and Standard Detail updates are available at:
<http://maine.gov/mdot/contractors/publications/standarddetail/>

<u>Detail #</u>	<u>Description</u>	<u>Revision Date</u>
502(19)	Bridge Drains	12/08/2021
507(20)	Steel Approach Railing 3-Bar	2/11/2021
507(21)	Steel Approach Railing 3-Bar	2/11/2021
507(22)	Steel Approach Railing 3-Bar	2/11/2021
507(23)	Steel Approach Railing 3-Bar	2/11/2021
507(27)	Steel Approach Railing	2/11/2021
526(01)	Portable Concrete Barrier	1/14/2021
526(01A)	Portable Concrete Barrier	1/14/2021
526(01B)	Portable Concrete Barrier	1/14/2021
526(02)	Portable Concrete Barrier	1/14/2021
526(02A)	Portable Concrete Barrier	1/14/2021
526(03)	Portable Concrete Barrier	1/14/2021
526(04)	Portable Concrete Barrier	1/14/2021
526(04A)	Portable Concrete Barrier	1/14/2021
526(04B)	Portable Concrete Barrier	1/14/2021
603(10)	Concrete Pipe Ties	6/10/2021
605(01)	Underdrain	8/13/2021
606(23)	Standard Bridge Transition – Type “1”	2/11/2021
606(24)	Standard Bridge Transition – Type “1A”	2/11/2021
608(02)	Detectable Warnings	6/10/2021
609(09)	Precast Concrete Vertical Curb	2/11/2021
643(11)	ATCC Cabinet	12/14/2020
801(11)	Pedestrian Ramp Notes	6/10/2021
801(12)	Pedestrian Ramp Requirements	8/13/2021
801(13)	Ramp Length Table	6/10/2021
801(14)	Parallel Pedestrian Ramp	6/10/2021
801(15)	Perpendicular Pedestrian Ramp – Option 1	6/10/2021
801(16)	Parallel Pedestrian Ramp – Option 2A	6/10/2021
801(17)	Perpendicular Pedestrian Ramp – Option 2A	6/10/2021

801(18)	Parallel Pedestrian Ramp – Option 2B	6/10/2021
801(19)	Perpendicular Pedestrian Ramp – Option 2B	6/10/2021
801(20)	Parallel Pedestrian Ramp – Option 3	6/10/2021
801(21)	Perpendicular Pedestrian Ramp – Option 3	6/10/2021
801(22)	Side Street Pedestrian Ramp	6/10/2021
801(23)	Parallel Pedestrian Ramp – Esplanade	6/10/2021
801(24)	Perpendicular Pedestrian Ramp – Esplanade	6/10/2021
801(25)	Island Crossings	6/10/2021
801(26)	Blended Transition	6/10/2021
801(27)	Pedestrian Ramp Adjacent to Driveway or Entrance	6/10/2021
802(05)	Roadway Culvert End Slope Treatment	1/03/2017

**SUPPLEMENTAL SPECIFICATIONS
(Corrections, Additions, & Revisions to Standard Specifications – March 2020)**

SECTION 101
CONTRACT INTERPRETATION

101.2 Definitions

Holidays Amend this paragraph by adding “**Juneteenth**” between ‘Memorial Day’ and ‘Independence Day’.

SECTION 102
BIDDING

102.11 Bid Responsiveness Revise the paragraph that states
“The Bid is not signed by a duly authorized representative of the Bidder.” So that it reads:

“The Bid is not signed by a duly authorized representative of the Bidder.

- **Properly submitted electronic bids meet this requirement.**
- **Paper bids must include at least one signed copy of the Contract Agreement Offer & Award form.”**

SECTION 104
GENERAL RIGHTS AND RESPONSIBILITIES

104.2.1 Furnishing of Right-of-Way Revise the last sentence in the first paragraph by removing “105.4.5 – Special Detours” and replacing it with “**105.4.5 – Maintenance of Existing Structures.**”.

SECTION 105
GENERAL SCOPE OF WORK

105.10.2 Requirements Applicable to All Contracts Under section A, number 2, in the first sentence of the first paragraph, revise this Section by replacing the word “handicap” in two places with the word “disability” so it now reads:

“2) The Contractor will, in all solicitations or advertisements for employees placed by or on behalf of the Contractor, State that all qualified applicants will receive consideration for employment without regard to race, color, sexual orientation, religious creed, sex, national origin, ancestry, age, physical disability, or mental disability.”

SECTION 106
QUALITY

106.6 Acceptance Revise this Subsection by replacing the paragraph beginning with “Acceptance of Hot Mix Asphalt Pavement will be based” with:

“Acceptance of Hot Mix Asphalt Pavement will be based on Method A or C Statistical Acceptance, or Method B or D Acceptance as specified. The method of acceptance for each item is defined in Special Provision, Section 403, Hot Mix Asphalt Pavement. When items of Hot Mix Asphalt Pavement are not so designated, Method A will be utilized whenever there are more than 1000 tons per Hot Mix Asphalt Pavement item, and Method B will be utilized when there are less than or equal to 1000 tons per Hot Mix Asphalt Pavement item.”

Revise Subsection “B” by removing it and replacing it with:

“B. Items not designated for Statistical Acceptance will utilize Method B or D Acceptance testing to validate the quality of the material incorporated into the Project. For material paid under Item 403.209 – Method D, or designated to be visually accepted, the Contractor shall provide the Department with a Certification Letter that indicates that the material supplied complies with the Specifications. Test results representative of the certified material shall be attached to the letter.

The Department will randomly sample and test the certified Material for properties noted in Table 1 of Section 502 - Structural Concrete or Table 14 of Section –401.21 Acceptance Method B & D. Material will be subject to rejection as noted in Structural Concrete Section 502.195 - Quality Assurance Method C Concrete or Hot Mix Asphalt, Section 401.2022 Pay Adjustment – Method B & D.”

106.7.1 Standard Deviation Method Revise 106.7.1, subsection H by removing the following from the first paragraph:

“Method B: $PF = [70 + (Quality\ Level * 0.33)] * 0.01$ ”

SECTION 107 TIME

107.3.1 General Amend this paragraph by adding “**Juneteenth**” between ‘Patriot’s Day’ and ‘the Friday after Thanksgiving’.

SECTION 110 INDEMNIFICATION, BONDING, AND INSURANCE

110.3.9 Administrative & General Provisions Amend this subsection by adding “**Automobile Liability**” under letter A) Additional Insured to the list of exceptions.

SECTION 206 STRUCTURAL EXCAVATION

206.01 Description – *Structural Earth Excavation, Below Grade* delete the entire sentence and replace with “**shall consist of the removal of excavation required for unknown or unanticipated subsurface condition. See 206.04 – Method of Measurement for pay limits.**”

206.04 Method of Measurement – Drainage and Minor Structures Paragraph 1, sentence 2, delete the remainder of the sentence beginning with “...provided the maximum allowable...”

And replace with: “**...in accordance with the following limits:**”

- **Vertical pay limits:**
 - **Below a plane parallel with and 12 inches below the bottom of the drainage or minor structure or**
 - **Below the excavation limits shown in the Bid Documents; whichever is greater.**

- **Horizontal pay limits** – **The maximum allowable horizontal dimensions shall not exceed those bounded by vertical surfaces 18 inches outside the base, or extreme limits of, the structure, and to the vertical neat lines of underdrain trenches, as shown in the Contract Documents.**

SECTION 401 HOT MIX ASPHALT PAVEMENT

401.19 Contractor Quality Control Amend this Section by adding the following to the end:
“**Failure to comply with the approved QCP will result in work suspension and pay reductions as outlined in Section 106.4.6. The Quality Control Plan Value shall be the total bid value for all items covered by the QCP as identified in Special Provision 403.**”

SECTION 502 STRUCTURAL CONCRETE

502.09 Forms and Falsework Amend this subsection by adding the subsection title “**502.10 Placing Concrete**” after section “D” Removal of Forms and False work” and after the paragraph beginning with “2. Forms and False work, including blocking...”. So that a new subsection starts and reads:

“**502.10 Placing Concrete**

A. **General Concrete shall not be placed until forms”**

502.1701 Quality Control, Method A and B Revise this Section so that the first paragraph and the first sentence of the second paragraph read:

502.17 Quality Control The Contractor shall control the quality of the concrete through testing, inspection, and practices which shall be described in the QCP, sufficient to assure a product meeting the Contract requirements. The QCP shall meet the requirements of Section 106, Quality, and this specification. No work under this item shall proceed until the QCP is submitted to and approved by the Department. Failure to comply with the approved QCP will result in work suspension and pay reductions as outlined in Section 106.4.6. The Quality Control Plan Value shall be the total bid value for all cast-in-place items covered by the QCP, using the P value listed in Special Provision 502. If no P value is listed, a value of \$350, or bid value per cubic yard, whichever is less, shall be used.

502.1701 Quality Control, Method A and B The QCP shall address all elements that affect the quality of the structural concrete including, but not limited to, the following: “

502.18, Method of Measurement, Revise Subsection ‘F’ by removing the word ‘transverse’ so that it reads: “Saw cut grooving of concrete wearing surfaces, complete and accepted, will be measured for payment as one lump sum.”

502.19, Basis of Payment, Revise the third paragraph by removing the word ‘transverse’ so that it reads: “Saw cut grooving of concrete wearing surfaces will be paid for at the Contract Lump Sum Price, which shall be payment for furnishing all materials, labor, and equipment, including depth gauges and all incidentals, to satisfactorily complete the work.”

(Also see 535.24 and 535.25 for related changes)

SECTION 503 REINFORCING STEEL

Section 503.07 Splicing Revise this section by removing the table and following footnote and replacing them with:

Minimum Lap Splice Length (inches)									
Bar Type	Bar Size								
	#3	#4	#5	#6	#7	#8	#9	#10	#11
Plain or Galvanized	16	20	24	29	38	47	59	72	85
Epoxy or Dual Coated	17	24	36	43	56	71	88	107	128
Stainless	19	24	30	36	47	59	73	89	107
Low-carbon Chromium	24	32	39	47	63	78	97	119	142

“The minimum lap splice lengths in the table above are based on the parameters below. When any of these parameters are altered, appropriate minimum lap splice lengths will be as shown on the Plans.

- Normal weight concrete
- Minimum 28-day concrete compressive strength from 4,000 psi to 10,000 psi

- **Class B tension lap splice**
- **Minimum center-to-center spacing between bars of 6 inches**
- **Minimum clear cover of 2 inches**
- **Nominal reinforcing steel yield strengths**
 - **Low-carbon Chromium = 100 ksi**
 - **Stainless = 75 ksi**
 - **All others = 60 ksi**
- **Reinforcement with yield strengths greater than 75 ksi shall have beam transverse reinforcement and column ties provided over the required lap splice length in accordance with the current edition of the AASHTO LRFD Bridge Design Specifications**

When lap splices are placed horizontally in an element where the concrete depth below the splice will be 12 inches, or more, the indicated lap splice lengths shall be multiplied by a factor of 1.3.”

SECTION 506 SHOP APPLIED PROTECTIVE COATING – STEEL

506.13 Surface Preparation Amend this section by adding this paragraph to the end:

“Steel shall meet the requirements of SSPC SP8 Pickling prior to being immersed in the zinc tanks. Verification of the surface preparation shall be included in the QC documentation.”

SECTION 523 BEARINGS

523.051 Protective Coating Revise this subsection by removing the paragraph beginning with “Anchor rods shall be galvanized...” and replacing with:

“Anchor rods shall be galvanized. When anchor rods are designated to secure bare unpainted steel or painted steel, a dielectric coating (epoxy or bituminous type coatings are acceptable) shall be applied to the anchor rod and/or adjacent steel to prevent contact between galvanized surfaces and painted or unpainted steel.”

523.22 Fabrication Amend this subsection by adding the following: **“Elastomeric Bearings shall be fabricated in accordance with AASHTO M251.”**

SECTION 526 CONCRETE BARRIER

Amend this section by deleting it in its entirety and replacing it with:

“526.01 Description This work shall consist of the furnishing, constructing, erecting, setting, resetting, and removal of concrete barrier and associated elements in accordance with these specifications, the Standard Details, and the lines and grades shown on the Plans or established by the Resident.

The types of concrete barrier are designated as follows:

Portable Concrete Barrier Type I Double faced removable barrier in accordance with the Standard Details.

Permanent Concrete Barrier Type II Double faced barrier as shown on the Plans.

Permanent Concrete Barrier Type IIIa Single faced barrier 32 inches high in accordance with the Standard Details or as shown on the Plans.

Permanent Concrete Barrier Type IIIb Single faced barrier 42 inches high in accordance with the Standard Details or as shown on the Plans.

Permanent Concrete Transition Barrier Barrier of various heights joining steel bridge rail to steel guardrail in accordance with the Standard Details or as shown on the Plans.

Permanent Texas Classic Rail Barrier Traffic rail or sidewalk rail, in accordance with the Standard Details or as shown on the Plans.

526.02 Materials

a. **Concrete** Concrete for barriers, both permanent and portable, shall have a design strength of 5,000 psi.

For cast-in-place barrier: The concrete shall be Class LP, in accordance with Standard Specification Section 502, Structural Concrete.

For precast barrier: The concrete shall meet the requirements of Standard Specification 712.061, Structural Precast Concrete Units, except that the stripping strength for precast barriers is 4,000 psi.

b. **Reinforcing Steel** Reinforcing steel shall meet the requirements of Section 503, Reinforcing Steel.

c. **Structural Steel** Plates and barrier connections shall meet the requirements specified in Standard Specification 504 - Structural Steel and shall be hot dip galvanized after fabrication in accordance with Standard Specification 506, Shop Applied Protective Coating – Steel

d. **Bolts** Bolts shall meet the requirements specified in Section 713.02, High Strength Bolts.

e. Connecting Pins for Portable Concrete Barrier Portable concrete barriers must be connected using a 1- inch diameter pin. The connecting pin must be smooth, not deformed, i.e., reinforcing bar may not be used, and shall meet the strength requirements of ASTM A449 steel. Materials with greater strength may be used with the approval of the Department.

f. Anchor Pins for Portable Concrete Barrier Anchoring to concrete or asphalt will be required when specified on the Plans. When required, portable concrete barriers must be anchored using a 1 ½ - inch diameter anchor pin. The anchor pin must be smooth, not deformed, i.e., reinforcing bar may not be used, and shall meet the strength requirements of ASTM A36 steel. Materials with greater strength may be used with the approval of the Department.

g. Device Crashworthiness MaineDOT is transitioning to MASH2016 criteria for Portable Concrete Barrier on the following schedule:

New Portable Concrete Barrier shall be crash tested and/or evaluated to MASH2016 criteria.

Current Portable Concrete Barrier in useful serviceable condition that is successfully tested to NCHRP Report 350 or MASH2009 criteria may be utilized through December 31, 2029.

Other current Portable Concrete Barrier that is deemed acceptable by the Department may be utilized on projects off the National Highway System through December 31, 2024.

526.03 Construction Requirements

Cast-in-place barriers shall be fabricated in accordance with Standard Specification Section 502, Structural Concrete. Precast barriers shall be fabricated in accordance with Standard Specification 534, Precast Structural Concrete.

Concrete finish for permanent barrier shall be rubbed as defined in Standard Specification Section 502, Structural Concrete, 502.13 D2 or an approved equal.

Portable concrete barrier shall be generally free from fins and porous areas and shall present a neat and uniform appearance.

Permanent barrier shall have a protective coating applied in accordance with Standard Specification Section 515, Protective Coating for Concrete Surfaces.

Reflective delineators for concrete median barrier shall meet the requirements of Special Provision 645, Highway Signing.

Preformed Joint Filler shall meet the requirements specified in Subsection 705.01, Preformed Expansion Joint Filler.

Permissible dimensional tolerances for all concrete barriers shall be as follows:

- a. Cross-sectional dimensions shall not vary from design dimensions by more than ¼ inch. The vertical centerline shall not be out of plumb by more than ¼ inch.**
- b. Longitudinal dimensions shall not vary from the design dimensions by more than ¼ inch per 10 feet of barrier section and shall not exceed ¾ inches per section.**
- c. Location of anchoring holes shall not vary by more than ½ inch from the dimensions shown in the concrete barrier details on the Plans.**
- d. Surface straightness shall not vary more than ¼ inch under a 10-foot straightedge.**
- e. The barrier shall have no significant cracking. Significant cracking is defined as fractures or cracks passing through the section, or any continuous crack extending for a length of 12 inches or more, regardless of position in the section.** **526.04 Method of Measurement** **Permanent Concrete Barrier Type II, IIIa, IIIb, Texas Classic Rail, and Precast Median Barrier will be measured for payment by lump sum, complete in place.**

Portable concrete barrier, both anchored and unanchored will be measured for payment by lump sum. Lump sum measurement will include verification of the installation and removal of all portable concrete at the completion of the Contractor's operations.

The Contractor shall replace sections of portable concrete barrier, including anchored barrier damaged by the traveling public when directed by the Resident. Replacement sections will be measured for payment in accordance with Standard Specification 109.7, Equitable Adjustments to Compensation and Time.

Transition barrier will be measured by each, complete in place.

526.05 Basis of Payment The accepted quantities of Concrete Barrier Type II, IIIa, IIIb, Texas Classic Rail, and Precast Median Barrier will be paid for at the Contract lump sum price for the type specified, complete in place.

The accepted quantities of Portable Concrete Barrier Type I, both anchored and unanchored will be paid for at the Contract lump sum price. Such payment shall be full compensation for furnishing all materials, assembling, moving, resetting, transporting, temporarily storing, removing barrier, furnishing new parts as necessary, and all incidentals necessary to complete the work.

Portable barrier shall become the property of the Contractor upon completion of the use of the barrier on the project and shall be removed from the project site by the Contractor.

Transition barrier will be paid for at the Contract price each, complete in place.

The accepted quantity of all types of concrete barrier, whether portable or permanent, will be paid for at the lump sum or per each price, as applicable, which payment shall be full compensation for all materials, including reinforcing steel, protective coating, reflective delineators, steel plates and hardware, equipment, labor and incidentals required, as necessary, to complete the work.

Payment will be made under:

	<u>Pay Item</u>	<u>Pay Unit</u>
526.301	Portable Concrete Barrier, Type I	Lump Sum
526.304	Portable Concrete Barrier, Anchored Type I	Lump Sum
526.312	Permanent Concrete Barrier Type II	Lump Sum
526.321	Permanent Concrete Barrier Type IIIa	Lump Sum
526.323	Texas Classic Rail	Lump Sum
526.331	Permanent Concrete Barrier Type IIIb	Lump Sum
526.34	Permanent Concrete Transition Barrier	Each
526.502	Precast Concrete Median Barrier	Lump Sum”

SECTION 527 ENERGY ABSORBING UNIT

527.02 Materials Amend this section by deleting it in its entirety and replacing it with:

“MaineDOT is transitioning to MASH2016 criteria for Work Zone Traffic Control Devices on the following schedule:

Portable Crash Cushions will be crash tested and/or evaluated to MASH2016 criteria by January 1, 2030. Current Category 3 devices in useful serviceable condition that are successfully tested to NCHRP Report 350 or MASH2009 criteria may be utilized through December 31, 2029.

Work Zone Crash Cushions shall be selected from the Department’s Qualified Products List of Crash Cushions/Impact Attenuators or approved equal.”

SECTION 535 PRECAST, PRESTRESSED CONCRETE SUPESTRUCTURE

535.24, Installation of Slabs, Beams, and Girders Revise the 5th paragraph by replacing “6.0 and 9.0” to “5.0 and 8.0” so it reads: **“Ready mixed grout shall achieve a design compressive strength of 6,000 psi at 28 days, have an entrained air content of between 5.0 and 8.0 percent, be non-shrink, flowable, and contain a non-shrink additive listed on the Department QPL for expansive cements.”**

535.25, Installation of Precast/Prestressed Deck Panels Revise the 2nd paragraph by replacing “6.0 and 9.0” to “5.0 and 8.0” so it reads: **“Ready mixed grout shall achieve a design compressive strength of 6,000 psi at 28 days, have an entrained air content of between 5.0 and 8.0 percent, be non-shrink, flowable, and contain a non-shrink additive listed on the Department QPL for expansive cements.”**

SECTION 606 GUARDRAIL

Amend this section by replacing it with the following:

606.01 Description This work shall consist of furnishing and installing guardrail components in accordance with these specifications and in reasonably close conformity with the lines and grades shown on the plans or as established. Guardrail is designated as:

31” W-Beam Guardrail - Mid-Way Splice

Galvanized steel w-beam, 8” wood or composite offset blocks, galvanized steel posts

Thrie Beam

Galvanized steel thrie beam, 8” wood or composite offset blocks, galvanized steel posts

Median guardrail shall consist of two beams of the above types, mounted on single posts.

Bridge mounted guardrail shall consist of furnishing all labor, materials, and equipment necessary to install guardrail as shown on the plans. This work shall also include drilling for and installation of offset blocks if specified, and incidental hardware necessary for satisfactory completion of the work.

Remove and Reset and Remove, Modify, and Reset guardrail shall consist of removing the existing designated guardrail and resetting in a new location as shown on the plans or directed by the Resident. Remove, Modify, and Reset guardrail and Modify guardrail include the following guardrail modifications: Removing plate washers at all posts, except at anchorage assemblies as noted on the Standard Details, adding offset blocks, and other modifications as listed in the Construction Notes or General Notes. Modifications shall conform to the guardrail Standard Details.

Bridge Connection shall consist of the installation and attachment of beam guardrail to the existing bridge. This work shall consist of constructing a concrete end post or modifying an existing end post as required, furnishing, and installing a terminal connector, necessary hardware, and incidentals required to complete the work as shown on the plans. Bridge Transition shall consist of a bridge connection and furnishing and installing guardrail components as shown in the Standard Details.

606.02 Materials Materials shall meet the requirements specified in the following Sections of Division 700 - Materials:

Timber Preservative	708.05
Metal Beam Rail	710.04
Guardrail Posts	710.07
Guardrail Hardware	710.08

Guardrail components shall meet the applicable standards of "A Guide to Standardized Highway Barrier Hardware" prepared and approved by the AASHTO-AGC-ARTBA Joint Cooperative Committee, Task Force 13 Report.

Posts for underdrain delineators shall be "U" channel steel, 8 ft long, 2 ½ lb/ft minimum and have 3/8-inch round holes, 1-inch center to center for a minimum distance of 2 ft from the top of the post.

Reflectorized Flexible Guardrail Markers shall be mounted on all guardrails. A marker shall be mounted onto guardrail posts at the flared guardrail terminal end point and tangent point, both at the leading and trailing ends of each run of guardrail. The marker's flexible posts shall be gray with either silver-white or yellow reflectors (to match the edge line striping) at the tangents, red at leading ends, and green at trailing ends. Whenever the guardrail terminal is not flared, markers will only be required at the terminal end point. These shall be red or green as appropriate. Markers shall be installed on the protected side of guardrail posts unless otherwise approved by the Resident. Reflectorized flexible guardrail markers shall be from the Department's Qualified Products List of Delineators. The marker shall be gray, flexible, durable, and of a non-discoloring material to which 3-inch by 9-inch reflectors shall be applied, and capable of recovering from repeated impacts and meeting MASH 16 requirements. Reflective material shall meet the requirements of Section 719.01 for ASTM D 4956 Type III reflective sheeting. The marker shall be secured to the guardrail post with two fasteners, as shown in the Standard Details.

Reflectorized beam guardrail ("butterfly"-type) delineators shall be mounted on all "w"-beam guardrail. The delineators shall be mounted within the guardrail beam at guardrail posts. Delineators shall be fabricated from high-impact, ultraviolet & weather resistant thermoplastic. Reflectorized beam guardrail delineators shall be placed at approximately 62.5 ft intervals or every tenth post on tangents and at approximately 31.25 ft intervals or every fifth post on curves. Exact locations of the delineators shall be as directed by the Resident. On divided highways, the left-hand delineators shall be yellow, and the right-hand delineators shall be silver/white. On two directional highways, the right-hand side shall be silver/white, and no reflectorized delineator used on the left. All reflectors shall have reflective sheeting applied to only one side of the delineator facing the direction of traffic as shown in the Standard Details. Reflectorized sheeting for guardrail delineators shall meet the requirements of Section 719.01.

Single wood post shall be of cedar, white oak, or tamarack, well-seasoned, straight, and sound and have been cut from live trees. The outer and inner bark shall be removed, and all knots trimmed flush with the surface of the post. Posts shall be uniform taper and free of kinks and bends.

Single steel post shall conform to the requirements of Section 710.07 b.

Single steel pipe post shall be galvanized, seamless steel pipe conforming to the requirements of ASTM A120, Schedule No. 40, Standard Weight.

Acceptable multiple mailbox assemblies shall be listed on the Department's Qualified Products List and shall be MASH 16 tested and approved.

Flared and Tangent w-beam guardrail terminals and guardrail offset blocks shall be from the Department's Qualified Products List. Flared terminals shall be installed with a 4 ft offset as shown in the Manufacturer's installation instructions.

Anchorage assemblies used to anchor trailing ends, radius guardrail, or other ends not exposed to traffic shall meet the applicable standards of "A Guide to Standardized Highway Barrier Hardware" prepared and approved by the AASHTO-AGC-ARTBA Joint Cooperative Committee, Task Force 13 Report, Drawing SEW02a.

Existing materials damaged or lost during adjusting, removing and resetting, or removing, modifying, and resetting, shall be replaced by the Contractor without additional compensation. Existing guardrail posts and guardrail beams found to be unfit for reuse shall be replaced when directed by the Resident.

606.03 Posts Posts for guardrail shall be set plumb in holes or they may be driven if suitable driving equipment is used to prevent battering and distorting the post. When posts are driven through pavement, the damaged area around the post shall be repaired with approved bituminous patching. Damage to lighting and signal conduit and conductors shall be repaired by the Contractor.

When set in holes, posts shall be on a stable foundation and the space around the posts, backfilled in layers with suitable material, thoroughly tamped.

The reflectorized flexible guardrail markers shall be set plumb with the reflective surface facing the oncoming traffic. Markers shall be installed on the protected side of guardrail posts. Markers, which become bent or otherwise damaged, shall be removed and replaced with new markers.

Single wood posts shall be set plumb in holes and backfilled in layers with suitable material, thoroughly tamped. The Resident will designate the elevation and shape of the top. The posts, that are not pressure treated, shall be painted two coats of good quality oil base exterior house paint.

Single steel posts shall be set plumb in holes as specified for single wood posts or they may be driven if suitable driving equipment is used to prevent battering and distorting the post.

Additional bolt holes required in existing posts shall be drilled or punched, but the size of the holes shall not exceed the dimensions given in the Standard Details. Metal around the holes shall be thoroughly cleaned and painted with two coats of approved aluminum rust resistant paint. Holes shall not be burned.

606.04 Rails Brackets and fittings shall be placed and fastened as shown on the plans. Rail beams shall be erected and aligned to provide a smooth, continuous barrier. Beams shall be lapped with the exposed end away from approaching traffic.

End assemblies shall be installed as shown on the plans and shall be securely attached to the rail section and end post.

All bolts shall be of sufficient length to extend beyond the nuts but not more than ½ inch. Nuts shall be drawn tight.

Additional bolt holes required in existing beams shall be drilled or punched, but the size of the holes shall not exceed the dimensions given in the Standard Details. Metal around the holes shall be thoroughly cleaned and painted with two coats of approved aluminum rust resistant paint. Holes shall not be burned.

606.045 Offset Blocks The same offset block material is to be provided for the entire project unless otherwise specified.

606.05 Shoulder Widening At designated locations the existing shoulder of the roadway shall be widened as shown on the plans. All grading, paving, seeding, and other necessary work shall be in accordance with the Specifications for the type work being done.

606.06 Mail Box Post Single wood post shall be installed at the designated location for the support of the mailbox. The multiple mailbox assemblies shall be installed at the designated location in accordance with the Standard Details and as recommended by the Manufacturer. Attachment of the mailbox to the post will be the responsibility of the home or business owner.

606.07 Abraded Surfaces All galvanized surfaces of new guardrail and posts, which have been abraded so that the base metal is exposed, and the threaded portions of all fittings and fasteners and cut ends of bolts shall be cleaned and painted with two coats of approved rust resistant paint.

606.08 Method of Measurement Guardrail will be measured by the linear foot from center to center of end posts along the gradient of the rail except where end connections are made to masonry or steel structures, in which case measurement will be as shown on the plans. When connected to radius rail, measurement will be to the end of the last tangent beam.

Guardrail terminal, reflectorized flexible guardrail marker, terminal end, anchorage assembly, bridge transition, bridge connection, multiple mailbox post, and single post will be measured by each unit of the kind specified and installed.

Widened shoulder will be measured as a unit of grading within the limits shown on the plans.

Excavation in solid rock for placement of posts will be paid under force account unless otherwise indicated in the Bid Documents.

606.09 Basis of Payment The accepted quantities of guardrail will be paid for at the contract unit price per linear foot for the type specified, complete in place. Reflectorized beam guardrail (“butterfly”-type) delineators will not be paid for directly but will be considered incidental to guardrail items. Reflectorized flexible guardrail marker, terminal end, anchorage assembly, bridge transition, bridge connection, multiple mailbox post, and single post will be paid for at the contract unit price each for the kind specified complete in place.

Guardrail terminals will be paid for at the contract price each, complete in place which price shall be full payment for furnishing and installing all components including the terminal section, posts, offset blocks, "w" beam, cable foundation posts, plates and for all incidentals necessary to complete the installation within the limits as shown on the Standard Details or the Manufacturer's installation instructions. Pay limits for a flared terminal will be 37.5 feet. Pay limits for a tangent terminal will be 50 feet. Each guardrail terminal will be clearly marked with the Manufacturer's name and model number to facilitate any future needed repair. Such payment shall also be full compensation for furnishing all material, excavating, backfilling holes, assembling, and all incidentals necessary to complete the work, except that for excavation for posts or anchorages in solid ledge rock, payment will be made under 109.7.5 – Force Account. Type III Retroreflective Adhesive Sheeting shall be applied to the approach buffer end sections and sized to substantially cover the end section. On all roadways, the ends shall be marked with alternating black and retroreflective yellow stripes. The stripes shall be 3 in wide and sloped down at an angle of 45 degrees toward the side on which traffic is to pass the end section. Guardrail terminals shall also include a set of installation drawings supplied to the Resident.

Anchorage to bridge end posts will be part of the bridge work. Connections thereto will be considered included in the unit bid price for guardrail.

Guardrail to be placed on a radius of curvature of 150 ft or less will be paid for under the designated radius pay item for the type guardrail being placed.

Widened shoulder will be paid for at the contract unit price each complete in place and will be full compensation for furnishing and placing, grading and compaction of aggregate subbase and any required fill material.

Adjust guardrail will be paid for at the contract unit price per linear foot and will be full compensation for adjusting to grade. Payment shall also include adjusting guardrail terminals where required.

Modify guardrail will be paid for at the contract unit price per linear foot and will be full compensation for furnishing and installing offset blocks, additional posts, and other specified modifications; removing, modifying, installing, and adjusting to grade existing posts and beams; removing plate washers and backup plates, and all incidentals necessary to complete the work. Payment shall also include removing and resetting guardrail terminals where required.

Remove and Reset guardrail will be paid for at the contract unit price per linear foot and will be full compensation for removing, transporting, storing, reassembling all parts, necessary cutting, furnishing new parts when necessary, reinstalling at the new location, and all other incidentals necessary to complete the work. Payment shall also include removing and resetting guardrail terminals when required.

Remove, Modify, and Reset guardrail will be paid for at the contract unit price per foot and will be full compensation for the requirements listed in Modify guardrail and Remove and Reset guardrail.

Bridge Connections will be paid for at the contract unit price each. Payment shall include, attaching the connection to the endpost including furnishing and placing concrete and reinforcing steel

necessary to construct new endposts if required, furnishing and installing the terminal connector, and all miscellaneous hardware, labor, equipment, and incidentals necessary to complete the work.

Bridge Transitions will be paid for at the contract unit price each. Payment shall include furnishing and installing the thrie beam or “w”-beam terminal connector, doubled beam section, and transition section, where called for, posts, hardware, precast concrete transition curb, and any other necessary materials and labor, including the bridge connection as stated in the previous paragraph.

No payment will be made for guardrail removed, but not reset and all costs for such removal shall be considered incidental to the various contract pay items.

Payment will be made under:

<u>Pay Item</u>	<u>Pay Unit</u>
606.1301 31” W-Beam Guardrail - Mid-Way Splice – Single Faced	Linear Foot
606.1302 31” W-Beam Guardrail - Mid-Way Splice – Double Faced	Linear Foot
606.1303 31” W-Beam Guardrail - Mid-Way Splice, 15’ Radius and Less	Linear Foot
606.1304 31” W-Beam Guardrail - Mid-Way Splice, Over 15’ Radius	Linear Foot
606.1305 31” W-Beam Guardrail - Mid-Way Splice Flared Terminal	Each
606.1306 31” W-Beam Guardrail - Mid-Way Splice Tangent Terminal	Each
606.1307 Bridge Transition (Asymmetrical) – Type IA	Each
606.1721 Bridge Transition - Type I	Each
606.1722 Bridge Transition - Type II	Each
606.1731 Bridge Connection - Type I	Each
606.1732 Bridge Connection - Type II	Each
606.178 Guardrail Beam	Linear Foot
606.25 Terminal Connector	Each
606.257 Terminal Connector - Thrie Beam	Each
606.259 Anchorage Assembly	Each
606.265 Terminal End-Single Rail - Galvanized Steel	Each
606.266 Terminal End-Single Rail - Corrosion Resistant Steel	Each
606.275 Terminal End-Double Rail - Galvanized Steel	Each
606.276 Terminal End-Double Rail - Corrosion Resistant Steel	Each
606.353 Reflectorized Flexible Guardrail Marker	Each
606.354 Remove and Reset Reflectorized Flexible Guardrail Marker	Each
606.356 Underdrain Delineator Post	Each
606.358 Guardrail, Modify	Linear Foot
606.362 Guardrail, Adjust	Linear Foot
606.365 Guardrail, Remove, Modify, and Reset	Linear Foot
606.366 Guardrail, Remove and Reset	Linear Foot
606.367 Replace Unusable Existing Guardrail Posts	Each
606.47 Single Wood Post	Each
606.48 Single Galvanized Steel Post	Each

606.50	Single Steel Pipe Post	Each
606.51	Multiple Mailbox Support	Each
606.568	Guardrail, Modify - Double Rail	Linear Foot
606.63	Thrie Beam Rail Beam	Linear Foot
606.64	Guardrail Thrie Beam - Double Rail	Linear Foot
606.65	Guardrail Thrie Beam - Single Rail	Linear Foot
606.66	Terminal End Thrie Beam	Each
606.70	Transition Section - Thrie Beam	Each
606.71	Guardrail Thrie Beam - 15 ft radius and less	Linear Foot
606.72	Guardrail Thrie Beam - over 15 ft radius	Linear Foot
606.73	Guardrail Thrie Beam - Single Rail Bridge Mounted	Linear Foot
606.74	Guardrail - Single Rail Bridge Mounted	Linear Foot
606.753	Widen Shoulder for Low Volume Guardrail End	Each
606.754	Widen Shoulder for Flared Guardrail Terminal	Each
606.78	Low Volume Guardrail End	Each
606.80	Buried-in-Slope Guardrail End	Each

SECTION 608 SIDEWALKS

Section 608.022 Detectable Warning Materials Standard Revise this section by removing the last sentence of this section beginning with “Concrete...” and replacing it with “**Concrete shall meet the requirements of Section 608.021, Sidewalk Materials, of this specification or may be a prepackaged concrete mix from the Department’s Qualified Products List (QPL).**”

SECTION 609 CURB

609.02 Materials Revise the paragraph beginning “The Contractor shall submit a concrete mix...” so that it reads:

“The Contractor shall submit a concrete mix design for the Portland Cement Concrete to the Resident, with a minimum designed compressive strength of 3000 psi concrete fill.”

609.03 Vertical Stone Curb, Terminal Section and Transition Sections and Portland Cement Concrete Curb, Terminal Sections and Transition Sections Revise this section by underlining the section number and title so that it reads in the spec book as:

“609.03 Vertical Stone Curb, Terminal Section and Transition Sections and Portland Cement Concrete Curb, Terminal Sections and Transition Sections”

Revise the last paragraph beginning with “The Contractor may elect...” so that it reads:

“The Contractor may elect to substitute concrete to backfill Stone Curbing or Stone Edging at their option. If the concrete backfill option is elected, the Concrete Fill shall meet the requirements of 609.02. The Contractor shall submit a concrete design for the Portland Cement Concrete, with a minimum designated compressive strength of 3000 PSI meeting the requirements of Class S or Class Fill Concrete. The Contractor may elect to choose a Prepackaged Concrete Mix from the Department’s Qualified Products list (QPL). Concrete backfill shall be completed in conformance with a Department supplied concrete backfill detail.”

SECTION 610

STONE FILL, RIPRAP, STONE BLANKET, AND STONE DITCH PROTECTION

610.02 Materials Amend this subsection by adding the following to the end of the material list:
“Stone Ditch Protection 703.29”

SECTION 618

SEEDING

618.08 Mulching Revise this Section so that the third sentence reads: “Mulch for Seeding Method Number 1 shall only be cellulous fiber mulch Section 619.04 (b) or straw mulch Section 619.04 (a).”

SECTION 619

MULCH

619.03 General Amend this Section by adding the following sentence to the end: **“Straw mulch shall be used in all wetland areas.”**

SECTION 626

FOUNDATIONS, CONDUIT, AND JUNCTION BOXES FOR HIGHWAY SIGNING, LIGHTING, AND SIGNALS

Section 626.021 Miscellaneous Materials Revise this section by removing the fourth paragraph beginning with “ All Concrete for concrete encasement...” and replace it with **“All concrete for concrete encasement of conduit shall be Class S or Class Fill concrete in accordance with the applicable requirements of Section 502 – Structural Concrete, or a Prepackaged Concrete Mix from the Department’s Qualified Products List (QPL).”**

Section 626.031 Conduit Revise the fifth paragraph beginning with “After the trench has been...” by removing the last sentence beginning with “Where concrete encasement...” and replacing it with **“Where concrete encasement is required around the conduit, the concrete shall meet Class S, Class Fill in accordance with the applicable requirements of Section 502 – Structural Concrete, or a Prepackaged Concrete Mix from the Department’s Qualified Products List (QPL).”**

626.034 Concrete Foundations Revise this Section by changing ‘626.037’ to ‘**626.036**’ in the Second Paragraph which begins with “Foundations shall consist of cast-in-place...”.

Revise the 10th paragraph beginning with “Before placing concrete, the required elbows...” by removing “...**in accordance with Standard Specification 633.**”

626.036 Precast Foundations Revise the last sentence of paragraph one so that it reads: **“Construction of precast foundations shall conform to the Standard Details and all requirements of 712.061.”**

SECTION 627 PAVEMENT MARKINGS

627.06 Application Revise this subsection by replacing the paragraph beginning with “ On other final pavement markings...” with the following:

“On other final pavement markings and on curb, where the paint is applied by hand painting or spraying, application shall be one uniform covering coat at least 16 mils thick. Before the paint has dried, the glass beads shall be applied by a pressure system that will force the glass beads onto the undried paint as uniformly as possible.

Painted lines and markings shall be applied in accordance with the manufacturer’s published recommendations. These recommendations will be supplied to the Resident prior to installation.”

SECTION 643 TRAFFIC SIGNALS

643.021 Materials Amend this subsection by adding the following at the end:

“MaineDOT is transitioning to MASH2016 criteria for Work Zone Traffic Control Devices on the following schedule:

Temporary Traffic Control Signals will be crash tested and/or evaluated to MASH2016 criteria by January 1, 2030. Current Category 4 devices in useful serviceable condition that are successfully tested to NCHRP Report 350 or MASH2009 criteria may be utilized through December 31, 2029.”

643.09 Service Connection Revise this subsection by removing the paragraph that begins with “Traffic signal services shall have...”.

And by removing the paragraphs beginning with “ A service ground rod shall be installed...” and “A total of 4, 10’ service...” and replace them with **“A total of 4, 10’ service ground rods shall be installed and properly connected together on the outside of the cabinet foundation. One ground rod shall be located at each corner and shall be either flush or slightly below finished grade. The connection between the ground rod and the ground wire shall be an**

exothermic connection such as a Cadweld. The ground wire from the interconnected ground rods shall be routed through a conduit in the foundation and into the base of the cabinet”.

SECTION 645 HIGHWAY SIGNING

Section 645.023 Sign Support Structures. Under letter “c.”, revise the fifth paragraph beginning with “In addition to the required details...” by removing the words **”and foundation”** from the 5th sentence.

Section 645.08 Method of Measurement. Revise the second paragraph beginning with “Bridge-type, cantilever and...” by removing the words **”including the foundation”** .

Section 645.09 Basis of Payment. Revise the third paragraph beginning with “The accepted bridge-type, cantilever and...” by removing the word **”foundation”** from the second sentence. Add the following sentence to the end of the paragraph **“Conduits, Junction Boxes, and Foundations will be paid for under Section 626.”**

SECTION 652 MAINTENANCE OF TRAFFIC

Amend this Section by adding the following new subsection:

“652.2.6 Device Crashworthiness MaineDOT is transitioning to MASH2016 criteria for Work Zone Traffic Control Devices on the following schedule:

Category 1 (Cones, Drums, Tubular Markers, Flexible Delineators, and similar devices that have little chance of causing windshield penetration, tire damage, or other significant effect on the control or trajectory of a vehicle) – All Category 1 devices will be manufacturer self-certified as MASH2016 by January 1, 2025. Current Category 1 devices in useful serviceable condition that are not self-certified as MASH2016 compliant may be utilized through December 31, 2024.

Category 2 (Barricades, Portable Sign Supports, Category 1 devices with attachments, and similar devices that are not expected to produce significant vehicular velocity change but may be otherwise hazardous) – All Category 2 devices will be crash tested and/or evaluated to MASH2016 criteria by January 1, 2025. Current Category 2 devices in useful serviceable condition that are successfully tested to NCHRP Report 350 or MASH2009 criteria may be utilized through December 31, 2024.

Category 3 (Portable Concrete Barrier, Portable Crash Cushions, Truck Mounted Attenuators, Category 2 devices weighing more than 100 pounds, and similar devices that are expected to produce significant vehicular velocity change or other harmful reactions) – All Category 3 devices will be crash tested and/or evaluated to MASH2016 criteria by January 1, 2030. Current Category 3 devices in useful serviceable condition that are successfully tested to

NCHRP Report 350 or MASH2009 criteria may be utilized through December 31, 2029. (See Standard Specification 526 for additional Portable Concrete Barrier information).

Category 4 (Trailer Mounted Devices: Arrow Boards, Temporary Traffic Control Signals, Area Lighting, Portable Changeable Message Sign, and other similar devices.) – All Category 4 devices will be crash tested and/or evaluated to MASH2016 criteria by January 1, 2030. Current Category 4 devices in useful serviceable condition that are successfully tested to NCHRP Report 350 or MASH2009 criteria may be utilized through December 31, 2029.”

652.4 Flaggers Revise the first paragraph of this section so that it reads:

“The Contractor shall furnish flaggers as required by the TCP or as otherwise specified by the Resident. All flaggers must have successfully completed a flagger test approved by the Department and administered by a Department-approved Flagger-Certifier who is employing that flagger. All flaggers must carry an official certification card with them while flagging that has been issued by their employer.”

SECTION 681

PRECAST AGGREGATE-FILLED, CONCRETE BLOCK GRAVITY WALL

681.08 Basis of Payment Amend this section by adding the Item Number “**681.10**” in front of the item “Precast Aggregate-Filled Concrete Block Gravity Wall” at the end of the section.

SECTION 703

AGGREGATES

Add the following to Section 703 - Aggregates

703.01 Fine Aggregate for Concrete Fine aggregate for concrete shall consist of natural sand or, when approved by the Resident, other inert materials with similar characteristics or combinations thereof, having strong, durable particles. Fine aggregate from different sources of supply shall not be mixed or stored in the same pile nor used alternately in the same class of construction or mix without permission of the Resident.

All fine aggregate shall be free from injurious amounts of organic impurities. Should the fine aggregate, when subjected to the colorimetric test for organic impurities, AASHTO T 21, produce a color darker than the reference standard color solution (laboratory designation Plate III), the fine aggregate shall be rejected.

Fine aggregate shall have a sand equivalent value of not less than 75 when tested in accordance with AASHTO T 176.

Fine aggregate sources shall meet the Alkali Silica Reactivity (ASR) requirements of Section 703.0201.

The fineness modulus shall not be less than 2.26 or more than 3.14. If this value is exceeded, the fine aggregate will be rejected unless suitable adjustments are made in proportions of coarse and fine

aggregate. The fineness modulus of fine aggregate shall be determined by adding the cumulative percentages of material by weight retained on the following sieves: Nos. 4, 8, 16, 30, 50, 100 and dividing by 100.

Fine aggregate, from an individual source when tested for absorption as specified in AASHTO T 84, shall show an absorption of not more than 2.3 percent.

Sieve Designation	Percentage by Weight Passing Square Mesh Sieves
$\frac{3}{8}$ inch	100
No. 4	95-100
No. 8	80-100
No. 16	50-85
No. 30	25-60
No. 50	10-30
No. 100	2-10
No. 200	0-5.0

703.02 Coarse Aggregate for Concrete Coarse aggregate for concrete shall consist of crushed stone or gravel having hard, strong, durable pieces, free from adherent coatings and of which the composite blend retained on the $\frac{3}{8}$ inch sieve shall contain no more than 15 percent, by weight of flat and elongated particles when performed in accordance with test method ASTM D 4791, Flat Particles, Elongated Particles, or Flat and Elongated Particles in Coarse Aggregate, using a dimensional ratio of 1:5.

The coarse aggregate from an individual source shall have an absorption no greater than 2.0 percent by weight determined in accordance with AASHTO T 85 modified for weight of sample.

The composite blend shall have a Micro-Deval value of 18.0 percent or less as determined by AASHTO T 327 or not exceed 40 percent loss as determined by AASHTO T 96.

Coarse aggregate sources shall meet the Alkali Silica Reactivity (ASR) requirements of Section 703.0201.

Coarse aggregate shall conform to the requirements of the following table for the size or sizes designated and shall be well graded between the limits specified.

Sieve Designation	Percentage by Weight Passing Square Mesh Sieves			
	A	AA	S	LATEX
Grading	1 inch	¾ inch	1½ inch	½ inch
Aggregate Size	1 inch	¾ inch	1½ inch	½ inch
2 inch			100	
1½ inch	100		95-100	
1 inch	95-100	100	-	
¾ inch	-	90-100	35-70	100
½ inch	25-60	-	-	90-100
⅜ inch	-	20-55	10-30	40-70
No. 4	0-10	0-10	0-5	0-15
No. 8	0-5	0-5	-	0-5
No. 16	-	-	-	-
No. 50	-	-	-	-
No. 200	0 - 1.5	0 - 1.5	0 - 1.5	0 - 1.5

703.0201 Alkali Silica Reactive Aggregates All coarse and fine aggregates proposed for use in concrete shall be tested for Alkali Silica Reactivity (ASR) potential under AASHTO T 303 (ASTM C 1260), Accelerated Detection of Potentially Deleterious Expansion of Mortar Bars Due to Alkali-Silica Reaction, prior to being accepted for use. Acceptance will be based on testing performed by an accredited independent lab submitted to the Department. Aggregate submittals will be required on a 5-year cycle, unless the source or character of the aggregate in question has changed within 5 years from the last test date.

As per AASHTO T 303 (ASTM C 1260): Use of a particular coarse or fine aggregate will be allowed with no restrictions when the mortar bars made with this aggregate expand less than or equal to 0.10 percent at 30 days from casting. Use of a particular coarse or fine aggregate will be classified as potentially reactive when the mortar bars made with this aggregate expand greater than 0.10 percent at 30 days from casting. Use of this aggregate will only be allowed with the use of cement-pozzolan blends and/or chemical admixtures that result in mortar bar expansion of less than 0.10 percent at 30 days from casting as tested under ASTM C 1567.

Acceptable pozzolans and chemical admixtures that may be used when an aggregate is classified as potentially reactive include, but are not limited to the following:

- a. Class F Coal Fly Ash meeting the requirements of AASHTO M 295
- b. Ground Granulated Blast Furnace Slag (Grade 100 or 120) meeting the requirements of AASHTO M 302
- c. Densified Silica Fume meeting the requirements of AASHTO M 307
- d. Lithium-based admixtures
- e. Metakaolin

Pozzolans or chemical admixtures required to offset the effects of potentially reactive aggregates will be incorporated into the concrete at no additional cost to the Department.

703.05 Aggregate for Sand Leveling Aggregate for sand leveling shall be sand of hard durable particles free from vegetable matter, lumps or balls of clay and other deleterious substances. The aggregate shall meet the grading requirements of the following table.

Sieve Designation	Percentage by Weight
	Passing Square Mesh Sieves
¾ inch	85-100
No. 200	0-5.0

703.06 Aggregate for Base and Subbase The following shall apply to Sections (a.) and (c.) below. The material shall have a Micro-Deval value of 25.0 or less as determined by AASHTO T 327. If the Micro- Deval value exceeds 25.0, the Washington State Degradation DOT Test Method T113, Method of Test for Determination of Degradation Value (January 2009 version) shall be performed, except that the test shall be performed on the portion of the sample that passes the ½ in sieve and is retained on the No. 10 sieve. If the material has a Washington Degradation value of less than 15, the material shall be rejected.

The material used in Section (b.) below shall have a Micro-Deval value of 25.0 or less as determined by AASHTO T 327. If the Micro-Deval value exceeds 25.0 the material may be used if it does not exceed 25 percent loss on AASHTO T 96, Resistance to Degradation of Small-Size Coarse Aggregate by Abrasion and Impact in the Los Angeles Machine.

Recycled Asphalt Pavement (RAP) shall not be used for or blended with aggregate base or subbase.

- a. Aggregate for base, Type A and B shall be crushed ledge or crushed gravel of hard durable particles free from vegetable matter, lumps or balls of clay and other deleterious substances. The gradation of the part that passes a 3 inch sieve shall meet the grading requirements of the following table:

Sieve Designation	Percentage by Weight	
	Passing Square Mesh Sieves	
	Type A	Type B
½ inch	45-70	35-75
¼ inch	30-55	25-60
No. 40	0-20	0-25
No. 200	0-6.0	0-6.0

At least 50 percent by weight of the material retained on the No. 4 sieve shall have at least one fractured face as tested by AASHTO T 335.

Type A aggregate for base shall only contain particles of rock that will pass the 2 inch square mesh sieve.

Type B aggregate for base shall only contain particles of rock that will pass the 4 inch square mesh sieve.

- b. Aggregate for base, Type C shall be crushed ledge or crushed gravel of hard durable particles free from vegetable matter, lumps or balls of clay and other deleterious substances. The material shall meet the grading requirements of the following table:

Sieve Designation	Percentage by Weight Passing Square Mesh Sieves	
	Type C	
4 inches	100	
3 inches	90-100	
2 inches	75-100	
1 inch	50-80	
½ inch	30-60	
No. 4	15-40	
No. 200	0-6.0	

At least 50 percent by weight of the material coarser than the No. 4 sieve shall have at least one fractured face as tested by AASHTO T 335.

- c. Aggregate for subbase shall be sand or gravel of hard durable particles free from vegetable matter, lumps or balls of clay and other deleterious substances. The gradation of the part that passes a 3 inch sieve shall meet the grading requirements of the following table:

Sieve Designation	Percentage by Weight Passing Square Mesh Sieves	
	Type D	Type E
½ in	35-80	
¼ inch	25-65	25-100
No. 40	0-30	0-50
No. 200	0-7.0	0-7.0

Type D aggregate for subbase gravel may contain up to 50 percent by weight Recycled Concrete Aggregate (RCA). When RCA is used, the portion of the resulting blend of gravel and RCA retained on a ½” square mesh sieve shall contain a total of no more than 5 percent by weight of other recycled materials such as brick, concrete masonry block, or asphalt pavement as determined by visual inspection.

RCA shall be substantially free of wood, metal, plaster, and gypsum board as defined in Note 9 in Section 7.4 of AASHTO M 319. RCA shall also be free of all substances that fall under the category of solid waste or hazardous materials.

Aggregate for subbase shall not contain particles of rock which will not pass the 6 inch square mesh sieve.

703.08 Recycled Asphalt Pavement Recycled asphalt pavement shall consist of salvaged asphalt materials from milled pavements or production waste that has been processed before use to meet the requirements of the job mix formula. It shall be free of winter sand, granular fill, construction debris, or other materials not generally considered asphalt pavement.

703.081 RAP for Asphalt Pavement Recycled Asphalt Pavement (RAP) may be introduced into hot-mix asphalt pavement at percentages approved by the Department according to the MaineDOT Policies and Procedures for HMA Sampling and Testing.

If approved by the Department, the Contractor shall provide documentation stating the source, test results for average residual asphalt content, and stockpile gradations showing RAP materials have been sized to meet the maximum aggregate size requirements of each mix designation. The Department will obtain samples for verification and approval prior to its use.

The maximum allowable percent of RAP shall be determined by the asphalt content, the percent passing the 0.075 mm sieve, the ratio between the percent passing the 0.075 mm sieve and the asphalt content, and Coarse Micro-Deval loss values as tested by the Department.

The maximum percentage of RAP allowable shall be the lowest percentage as determined according to Table 4 below:

Classification	Maximum RAP Percentage Allowed	Asphalt content standard deviation	Percent passing 0.075 mm sieve standard deviation	Percent passing 0.075 mm sieve / asphalt content ratio	Residual aggregate M-D loss value
Class III	10%	≤ 1.0	N/A	≤ 4.0	≤ 18
Class II	20%	≤ 0.5	≤ 1.0	≤ 2.8	
Class I	30%	≤ 0.3	≤ 0.5	≤ 1.8	

Table 4: Maximum Percent RAP According to Test Results

The Department will monitor RAP asphalt content and gradation during production by testing samples from the stockpile at approximately 15,000 T intervals (in terms of mix production). The

allowable variance limits (from the numerical average values used for mix designs) for this testing are determined based upon the maximum allowable RAP percentage and are shown below in Table 5.

Table 5: RAP Verification Limits

Classification	Asphalt content (compared to aim)	Percent passing 0.075 mm sieve (compared to aim)
Class III	± 1.5	± 2.0
Class II	± 1.0	± 1.5
Class I	± 0.5	± 0.7

For specification purposes, RAP will be categorized as follows:

Class III – A maximum of 10.0 percent of Class III RAP may be used in any base, intermediate base, surface, or shim mixture. A maximum of 20.0 percent of Class III RAP may be used in hand-placed mixes for item 403.209.

Class II – A maximum of 20.0 percent Class II RAP in any base, binder, surface, or shim course.

Class I – A maximum of 20.0 percent Class I RAP may be used in any base, intermediate base, surface, or shim mixture without requiring a change to the specified asphalt binder. A maximum of 30.0 percent Class I RAP may be used in in any base or intermediate base mixture provided that a PG 58-28 or PG 58-34 asphalt binder is used. A maximum of 30.0 percent Class I RAP may be used in any surface or shim mixture provided that PG 58-34 asphalt binder is used. Mixtures exceeding 20.0 percent Class I RAP must be evaluated and approved by the Department.

The Contractor may use up to two different RAP sources in any one mix design. The total RAP percentage of the mix shall not exceed the maximum allowed for the highest classification RAP source used (i.e. if a Class I & Class III used, total RAP must not exceed 30.0%). The blended RAP material must meet all the requirements of the classification for which the RAP is entered (i.e. 10% Class III with 20% Class I, blend must meet Class I criteria). The Department may take belt cuts of the blended RAP to verify the material meets these requirements. If the Contractor elects to use more than one RAP source in a design, the Contractor shall provide an acceptable point of sampling blended RAP material from the feed belt.

In the event that RAP source or properties change, the Contractor shall notify the Department of the change and submit new documentation stating the new source or properties a minimum of 72 hours prior to the change to allow for obtaining new samples and approval.

SECTION 710 FENCE AND GUARDRAIL

710.06 Fence Posts and Braces Revise the first Paragraph so that it reads:

“Wood posts shall be of cedar, white oak, or tamarack or other AWPAs approved species, of the diameter or section and length shown on the plans.”

Remove the fourth paragraph which starts “ That portion of wood posts...”.

Revise the paragraph beginning with “Braces shall be of spruce, eastern hemlock ... so that it now reads:

“Braces shall be of spruce, eastern hemlock, Norway pine, pitch pine, or tamarack timbers or other AWPAs approved species, or spruce, cedar, tamarack or other AWPAs approved species round posts of sufficient length to make a diagonal brace between adjacent posts. All wood posts and braces shall be pressure-treated in accordance with AASHTO M 133 and AWPAs U1, UC4A Commodity Specification B: Posts. “

710.07 Guardrail Posts Revise this section so that the first sentence of section a. reads:

“a. Wood posts shall be of Norway pine, southern yellow pine, pitch pine, Douglas fir, red pine, white pine, or eastern hemlock or other AWPAs approved species.”

Revise the next paragraph so that it reads:

Wood posts and offset brackets shall be preservative treated in accordance with the requirements of AASHTO M 133 and AWPAs U1, UC4A Commodity Specification B: Posts.

710.08 Guardrail Hardware Revise this subsection by replacing “AASHTO M 298” with “ASTM B965”

SECTION 712 MISCELLANEOUS HIGHWAY MATERIAL

712.061 Structural Precast Units Amend this section by adding the following sentence to the end of the first paragraph of the Construction subsection:

“Facilities certified by NPCA or PCI shall provide to the Fabrication Engineer a copy of their annual audit to include deficiency reports and corrective actions.”

Revise this section by changing the letter “b” of ASTM C1611 of the Concrete Testing subsection so that it reads:

“b. Air content shall be 5.0% to 8.0%.”

SECTION 713 STRUCTURAL STEEL AND RELATED MATERIAL

Section 713.02 High Strength Bolts

Revise the second sentence of this subsection so that it reads **“Nuts shall meet the requirement of ASTM A563”**. Revise the third sentence of this subsection so that it reads **“Circular and beveled washers shall conform to the requirement of ASTM F436”**.

SECTION 718 TRAFFIC SIGNALS MATERIAL

718.03 Signal Mounting Amend the paragraph beginning with “All trunions, brackets and...” by adding **“For polycarbonate signal heads with more than 3 sections or requiring mounting extensions greater than 12 inches in length, reinforcing plates shall be used to reinforce the housings at the point of attachment.”** to the end of the paragraph.

718.08 Controller Cabinet Revise this subsection by replacing the paragraph beginning with “The cabinet shall be supplied with LED light panels...” on or about page 7-66 with **“The cabinet shall be supplied with white LED light panels which shall automatically illuminate via a door open switch whenever one of the four main cabinet doors are opened for the ground mount cabinet or two main doors for the side of pole cabinet. The ground mounted cabinet shall contain four LED light panels per side totaling eight panels for the cabinet; one panel each at the top and bottom portion of the front side and back side on the Control side and Power/Auxiliary side of the cabinet. Each light panel shall produce a minimum of 250 lumens for a total minimum lumen output of 2000 lumens with all eight panels illuminated. The minimum output per side would be 1000 lumens. The LED panels shall be protected by a clear shatterproof shield. The side of pole mounted cabinet shall contain four light panels; one at the top of the rack assembly and one at the bottom rack assembly on each side of the cabinet. A second door open status switch per door shall activate a controller input to log a report event that one of the doors was opened. All door open status switches shall be connected to the same controller input. For the ground mount cabinet, there shall be two switches on each of the four main doors. For the side-of-pole mount cabinet, there shall be two switches on each of the two main doors.”**

Revise this subsection by replacing the paragraph beginning with “The cabinet shall be supplied with a generator panel ...” on or about page 7-68 with:

“The cabinet shall be supplied with a generator panel. The generator panel shall

consist of a manual transfer switch and a twist-lock connector for generator hookup. The transfer switch knob and twist-lock connector shall be located inside a stainless steel enclosure with a separate lockable door accessed with a Corbin #2 key. The unit shall be mounted on the left, exterior of the control side wall of the ground mount cabinet a minimum of 36" above the surrounding grade and on the lower left side of the pole mounted cabinet. The generator transfer switch shall be a Reliance C30A1N Signa Series or approved equal. "

Revise this subsection by removing the following from the paragraph beginning with "The ground mounted cabinet shall be supplied and installed with an electric service meter socket trim and electrical service disconnect switch ..." on or about page 7-69: **"(removed: thus preventing that space from being used either by equipment supplied as part of the project, or future equipment that would be installed in the rack system. Joe indicated that he would add this language to the detail so it is covered.)"**

Revise this subsection by replacing the following in the paragraph beginning with "The Contractor shall reconfigure the default user name..." on or around page 7-70; "MaineDOT IT" with **"MaineDOT Traffic Division"**.

In the paragraph beginning with "Tests shall be conducted by the contractor..." on or around page 7-73, amend this subsection by removing **"in the state of Maine and"** after "The facility shall be".

Amend this Section by adding the following subsection:

718.13 Field Monitoring Unit (FMU) This item of work shall conform to this specification. This item shall consist of furnishing and installing a Field Monitoring Unit (FMU) and software, as well as all needed accessories required for a full and complete installation, including but not limited to power adapters, Ethernet cables, and interface cables, as described herein.

Where applicable, communications from MaineDOT's cloud-based Central Management System (CMS) to the on-street traffic signal controllers shall be made through fiber optic interconnect cable connected back to existing internet connections and/or the Field Monitoring Unit (FMU). The Contractor shall furnish and install all materials necessary for a complete and operational fiber optic interconnection to all project intersections as shown on the plans. All connections to the CMS cloud-based system shall be via a secure VPN network.

The FMU shall be the only remote connection device used by isolated intersections to connect to the cloud-based system. All connections shall be encrypted VPN tunnels. The Contractor shall coordinate all configuration settings with MaineDOT IT and the Engineer.

The FMU central web based interface shall be a separate element from the CMS.

MATERIALS: The materials for this work shall conform to the following requirements:

1. The work under this item specifies the requirements for the FMU. The FMU shall operate independent of the brand/type of intersection controller deployed in the ATC traffic cabinet.
2. The FMU shall conform to the following requirements:

- 2.1 The FMU shall function correctly between -34 degrees C and +74 degrees C.
- 2.2 The FMU shall be provided with appropriately rated connectors that allows the FMU to be exchanged by unplugging connectors, without tools.
- 2.3 The FMU shall monitor and log all ATC Controller and ATC cabinet faults and or alarms.
- 2.4 The FMU shall be wired directly to the ATC cabinet.
- 2.5 The FMU shall have an internal cellular modem running at 4G LTE.
 - 2.5.1 The Cellular modem shall be designed to be replaced / upgraded to 5G service when available.
- 2.6 The FMU shall incorporate an integrated GPS and cell modem.
- 2.7 The configuration of the FMU shall be accomplished by accessing the internal web server with a browser. It shall be possible to configure the FMU without any special software.
- 2.8 The FMU shall be powered via a standard 120V input power.
- 2.9 The FMU shall allow for the routing of the controller configuration packets to and from the controller (either by Ethernet or serial communications) for any type of controller utilized by the MaineDOT. In this way it shall be possible to configure the controller and utilize the controller specific software to interrogate the controller, and the FMU shall provide the communications pipe which allows this to be accomplished.
- 2.10 The FMU shall, within the size limitations above, include a battery and battery charging/monitoring circuit, to allow the FMU to function correctly even when all power to the intersection has failed. The battery shall continue to power the FMU for a minimum of 5 hours after all power has failed to the intersection.
- 2.11 The FMU shall incorporate an integrated GPS which will allow the FMU to geo-locate itself on the FMU management software map, without configuration.
- 2.12 The FMU shall operate without requiring a static IP address. The only configuration required at the FMU is to enter the URL of where the FMU management software is hosted.
- 2.13 In the event that the cell service is interrupted or is not available, the FMU shall store any events that occur in internal memory and forward these events automatically to the FMU management software when the cell service is restored. In this way, a complete record of events at the device can be maintained even if cell service is interrupted for a period. The system will store 5000 events.
- 2.14 The FMU shall utilize HTTP and HTTPS protocols, and XML data structures, for communication with the FMU management software. In this way the data will be open

for future expansion and competition. The use of secret proprietary protocols is not permitted.

- 2.15 The FMU shall include Ethernet communications via an Ethernet Port with RJ45 connector.
- 2.16 The FMU shall include weather proof antennas.

3. Map Display FMU Management Software

- 3.1 The FMU shall include a scrollable, zoomable map display, with the intersections and other monitored devices shown as representative icons on the map. The map shall include the ability to see the intersections using Google Streetview.
- 3.2 The alarm status of the intersection shall be clearly indicated on the icon on the map, so that the user can see at a glance which intersections are in alarm.
- 3.3 The map display shall also include a list of intersections, with the number and priority of alarms indicated on the list. Intersections in high priority alarm shall be moved to the top of the list, followed by medium priority, low priority and then finally by intersections not in alarm.
- 3.4 The icons shall change to be able to clearly indicate if an intersection is offline.
- 3.5 Clicking on the icon on the map shall expose a box with the current parameters of the intersection shown.
- 3.6 The default map display position and zoom shall be configurable by user, so that the user's view will default to show the intersections that the user is responsible for managing.
- 3.7 The map view shall have the ability to show Google traffic overlays on the map.

4. Intersection Detail Display FMU Management Software

- 4.1 It shall be possible to drill down, either from the map icon or from the list, to a device level detail for the intersection, which as a minimum shall display the following parameters:
 - 4.1.1 The alarm status, with priority indicated, and a text description of the alarm (if an alarm is present for this device).
 - 4.1.2 The time since the last communication with the device
 - 4.1.3 The following parameters (real time now values, minimum for the day values, maximum for the day values, and average for the day values)
 - 4.1.3.1 The AC mains voltage (value)
 - 4.1.3.2 The battery back-up voltage (value)

- 4.1.3.3 The cabinet temperature (value)
- 4.1.3.4 The cabinet humidity (value)
- 4.1.3.5 The presence of AC power (OK or Fail)
- 4.1.3.6 The flashing status of the intersection (OK or Flashing)
- 4.1.3.7 Stop Time status (OK or Stop Time Active)
- 4.1.3.8 The cabinet door status (Open or Closed)
- 4.1.3.9 The intersection fan status (Fan On or Fan off)
- 4.1.4 It shall be possible to view graphs of each of the value parameters in graphical form, over the recent two-week period. This includes real time graphs of:
 - 4.1.4.1 The AC mains voltage
 - 4.1.4.2 The battery back-up voltage
 - 4.1.4.3 The cabinet temperature
 - 4.1.4.4 The cabinet humidity

5. **Diagnostics and Log Display FMU Management Software**

- 5.1 From the device level detail within the FMU management software, it shall be possible to drill down to get the raw data; the error logs; and the communications logs to allow a technician to fault-find problems.
- 5.2 It shall be possible to filter the logs by Device; by Device Type and/or by Group as well as between dates.
- 5.3 It shall be possible to print these selected logs to a local printer or a PDF file.
- 5.4 It shall be possible to export these logs to Excel on the local computer for further analysis.

6. **Alarms FMU Management Software**

- 6.1 The FMU management software shall have a comprehensive alarm generation capability
- 6.2 It shall be possible to configure alarms to be generated on any parameter becoming out of tolerance, including analog values, digital values and enumerated values.
- 6.3 Alarms shall be configurable to be of Low, High or Critical Priority.
- 6.4 The alarm priority shall be displayed throughout the FMU management software, on all displays, using color codes such as red-critical; yellow – high; and amber-low to indicate the priority of the alarm.

6.5 The current active alarms shall be accessible for view via an expandable window, to see which alarms are active and when the alarm occurred. The highest priority alarms shall rise to the top of the list.

7. Alerts FMU Management Software

7.1 The FMU management software shall have comprehensive alerting capability, to enable the response personnel to be notified when an abnormal situation has occurred.

7.2 It shall be possible to configure alerts to one or more personnel for each alarm. This will cause, as selected, an SMS and/or an email to be sent to the person when an alarm occurs.

7.3 The alert shall be configurable to optionally send via email and/or via SMS a message when an alarm clears.

7.4 The intention is that the FMU management software provides the alerts to the user in near real time. The SMS and email shall be issued within 30 seconds of the occurrence of event which results in an alert being issued.

8. Hosting and Connectivity and Service FMU / FMU Management Software

8.1 The contractor shall supply the FMU with the FMU manufacturers 10 year options for Connectivity and Service, as part of the purchase price. The Connectivity and Service agreement shall include at a minimum:

8.1.1 Cellular Connectivity

8.1.2 No cellular overage charges

8.1.3 Extended warranty on the hardware for the period of the Connectivity and Service Agreement

8.1.4 Over-the-air software updates

8.1.5 Over-the-air security updates

8.1.6 Future Connected Vehicles Service

SECTION 720
STRUCTURAL SUPPORTS FOR HIGHWAY SIGNS, LUMINAIRES AND
TRAFFIC SIGNALS

720.12 Wood Sign Posts Revise the first sentence so that it reads:

Wood sign posts shall be rectangular, straight and sound timber, cut from live growing native spruce, red pine, hemlock, cedar trees or other AWPAs approved species, free from loose knots or other structurally weakening defects of importance, such as shake or holes or heart rot.

Revise the third paragraph that starts with “When pressure treated...” so that it reads:

All sign posts shall be pressure-treated in accordance with AASHTO M 133 and AWPAs Standard U1, UC4A, Commodity Specification A: Sawn Products.