

Updated 2/5/2026

FEDERAL PROJECT

BIDDING INSTRUCTIONS

FOR ALL PROJECTS:

1. Use pen and ink to complete all paper Bids.
2. As a minimum, the following must be received prior to the time of Bid opening:

For a Paper Bid:

- a) a copy of the Notice to Contractors, b) the completed Acknowledgement of Bid Amendments form, c) the completed Schedule of Items, d) two copies of the completed and signed Contract Offer, Agreement & Award form, e) a Bid Guaranty, (if required), and f) any other certifications or Bid requirements listed in the Bid Documents as due by Bid opening.

For an Electronic Bid:

NOTE: Not all projects accept Electronic Bids. Please review the Notice to Contractors and see if it specifically states that Electronic Bids will be accepted.

- a) a completed Bid using Expedite® software and submitted via the Bid Express™ web-based service, b) an electronic Bid Guaranty (if required) or a faxed copy of a Bid Bond (with original to be delivered within 72 hours), and c) any other Certifications or Bid requirements listed in the Bid Documents as due by Bid opening.
3. Include prices for all items in the Schedule of Items (excluding non-selected alternates).
4. Bid Guaranty acceptable forms are:
 - a) a properly completed and signed Bid Bond on the Department's prescribed form (or on a form that does not contain any significant variations from the Department's form as determined by the Department) for 5% of the Bid Amount or
 - b) an Official Bank Check, Cashier's Check, Certified Check, U.S. Postal Money Order or Negotiable Certificate of Deposit in the amount stated in the Notice to Contractors or
 - c) an electronic bid bond submitted with an electronic bid.
5. If a paper Bid is to be sent, "FedEx First Overnight" delivery is suggested as the package is delivered directly to the DOT Headquarters Building located at 16 Child Street in Augusta. Other means, such as U.S. Postal Service's Express Mail has proven not to be reliable.

IN ADDITION, FOR FEDERAL AID PROJECTS:

6. Complete the DBE Proposed Utilization form, and submit with your bid. If you are submitting your bid electronically, you must FAX the form to (207) 624-3431. This is a curable defect.

If you need further information regarding Bid preparation, call the DOT Contracts Section at (207) 624-3410.

For complete bidding requirements, refer to Section 102 of the Maine Department of Transportation, Standard Specifications, March 2020 Edition.

February 5, 2026
Supersedes April 28, 2017

NOTICE

The Maine Department of Transportation is attempting to improve the way Bid Amendments/Addendums are handled and allow for an electronic downloading of bid packages from our website, while continuing to maintain an optional plan holders list.

Prospective bidders, subcontractors or suppliers who wish to download a copy of the bid package and receive a courtesy notification of project specific bid amendments must fill out the on-line plan holder registration form and provide an email address to the MDOT Contracts mailbox at: MDOT.contracts@maine.gov. Each bid package will require a separate request.

Additionally, interested parties will be responsible for reviewing and retrieving the Bid Amendments from our web site, and acknowledging receipt and incorporating those Bid Amendments in their bids using the Acknowledgement of Bid Amendment Form.

The downloading of bid packages from the MDOT website is not the same as providing an electronic bid to the Department. Electronic bids must be submitted via <http://www.BIDX.com>. For information on electronic bidding contact Guy Berthiaume at guy.berthiaume@maine.gov.

NOTICE

For security and other reasons, all Bid Packages which are mailed, shall be provided in double (one envelope inside the other) envelopes. The *Inner Envelope* shall have the following information provided on it:

Bid Enclosed - Do Not Open

PIN:

Town:

Date of Bid Opening:

Name of Contractor with mailing address and telephone number:

In Addition to the usual address information, the *Outer Envelope* should have written or typed on it:

Double Envelope: Bid Enclosed

PIN:

Town:

Date of Bid Opening:

Name of Contractor:

This should not be much of a change for those of you who use Federal Express or similar services.

Hand-carried Bids may be in one envelope as before, and should be marked with the following information:

Bid Enclosed: Do Not Open

PIN:

Town:

Name of Contractor:

October 16, 2001

STATE OF MAINE DEPARTMENT OF TRANSPORTATION
Bid Guaranty-Bid Bond Form

KNOW ALL MEN BY THESE PRESENTS THAT _____

_____, of the City/Town of _____ and State of _____

as Principal, and _____ as Surety, a

Corporation duly organized under the laws of the State of _____ and having a usual place of

Business in _____ and hereby held and firmly bound unto the Treasurer of

the State of Maine in the sum of _____, for payment which Principal and Surety bind

themselves, their heirs, executors, administrators, successors and assigns, jointly and severally.

The condition of this obligation is that the Principal has submitted to the Maine Department of

Transportation, hereafter Department, a certain bid, attached hereto and incorporated as a

part herein, to enter into a written contract for the construction of _____

_____ and if the Department shall accept said bid

and the Principal shall execute and deliver a contract in the form attached hereto (properly

completed in accordance with said bid) and shall furnish bonds for this faithful performance of

said contract, and for the payment of all persons performing labor or furnishing material in

connection therewith, and shall in all other respects perform the agreement created by the

acceptance of said bid, then this obligation shall be null and void; otherwise it shall remain in full

force, and effect.

Signed and sealed this _____ day of _____ 20_____

WITNESS:

WITNESS

PRINCIPAL:

By _____

By: _____

By: _____

SURETY:

By _____

By: _____

Name of Local Agency: _____

NOTICE

Bidders:

Please use the attached “Request for Information” form when submitting questions concerning specific Contracts that have been advertised for Bid, include additional numbered pages as required. RFI’s may be faxed to 207-624-3431, submitted electronically through the Departments web page of advertised projects by selecting the RFI tab on the project details page or via e-mail to RFI-Contracts.MDOT@maine.gov.

These are the only allowable mechanisms for answering Project specific questions. Maine DOT will not be bound to any answers to Project specific questions received during the Bidding phase through other processes.

When submitting RFIs by Email please follow the same guidelines as stated on the “Request for Information” form and include the word “RFI” along with the Project name and Identification number in the subject line.

NOTICE

BIDDER'S LIST FORM

All Bidders must submit the Bidder's List Form with their bid.

The Bidder's List Form contains information required by USDOT.

The Bidder's List Form must be completed by each Prime Contractor.

A copy of the new Bidder's List Form and instructions for completing it are attached.

The DBE Directory can be found on the MaineDOT Website at: <https://www.maine.gov/mdot/civilrights/dbe/>

Questions about the Directory or this form should be sent to the Civil Rights Office at mary.bryant@maine.gov or by calling 207-624-3056.

INSTRUCTIONS FOR PREPARING THE MAINEDOT BIDDER'S LIST FORM

The Contractor shall extend equal opportunity to MaineDOT certified DBE firms (as listed in MaineDOT's DBE Directory of Certified Businesses) in the selection and utilization of subcontractors and suppliers.

Each prime contractor submitting a bid on a federally funded project must complete each section of the Bidder's List Form in its entirety for itself and each subcontractor on that project.

SPECIFIC INSTRUCTIONS FOR COMPLETING THE FORM:

Section A:

1. Insert Prime Contractor Name
2. Insert WIN for the Federal Project bidding on
3. Insert Bid Date
4. Insert Project Location
5. Insert Email address of Contact Person

Section B:

- A. Enter each Contractor's and Sub-Contractor's name and address (including zip code) – Prime Contractor's name should be listed in first box of this section; then each additional line would be proposed subcontractors – DBE and NonDBE
- B. Enter each Contractor's and Sub-Contractor's annual gross receipts bracket (see the legend on the form)
- C. Enter DBE status (DBE or non-DBE) for each contractor/sub-contractor
- D. Enter each Contractor's and Sub-Contractor's NAICS (North Amer. Industry Classification System) code (may be more than one) and Scope of Work
- E. For each Contractor and Sub-Contractor enter the Race and Gender of the firm's majority owner
- F. Enter the Age of each firm for every Contractor and Sub-Contractor
- G. Enter the Proposed amount of payment (Bid amount) for each Contractor/Sub-Contractor.

DBE GOAL NOTICE
Maine Department of Transportation
Disadvantaged Business Enterprise Program

Notice is hereby given that in accordance with US DOT regulation 49 CFR Part 26, the Maine Department of Transportation (MaineDOT) has established a Disadvantaged Business Enterprise Program (DBE) for disadvantaged business participation in the federal-aid highway and bridge construction programs; MaineDOT contracts covered by the program include consulting, construction, supplies, manufacturing, and service contracts.

Beginning September 1, 2024, MaineDOT has established an annual DBE participation goal of **1.43%** to be achieved through race/gender neutral means. This goal has been approved by the Federal Highway Administration through August 31, 2027. MaineDOT must meet this goal each federal fiscal year. If the goal is not met, MaineDOT must provide a justification for not meeting the goal and provide a plan to ensure the goal is met, which may include contract goals on certain projects that contractors will be required to meet.

MaineDOT asks all contractors, consultants and subcontractors to seek certified DBE firms for projects and to work to meet the determined 1.43% goal without the need to impose contract goals. DBE firms are listed on the MaineDOT website at:

<http://www.maine.gov/mdot/disadvantaged-business-enterprises/pdf/directory.pdf>

Interested parties may view MaineDOT's DBE goal setting methodology, also posted on this website. If you have questions regarding this goal or the DBE program you may contact Sherry Tompkins at the Maine Department of Transportation, Civil Rights Office by telephone at (207) 624-3066 or by e-mail at: sherry.tompkins@maine.gov

Maine Department of Transportation Civil Rights Office

Directory of Certified Disadvantaged Business Enterprises

Listing can be found at:

<https://www.maine.gov/mdot/civilrights/dbe/>

For additional information and guidance contact:

Civil Rights Office at (207) 624-3056

It is the responsibility of the Contractor to access the DBE Directory at this site in order to have the most current listing.

Vendor Registration

Prospective Bidders must register as a vendor with the Department of Administrative & Financial Services if the vendor is awarded a contract. Vendors will not be able to receive payment without first being registered. Vendors/Contractors will find information and register through the following link –

<http://www.maine.gov/purchases/venbid/index.shtml>

STATE OF MAINE DEPARTMENT OF TRANSPORTATION NOTICE TO CONTRACTORS

Sealed Bids addressed to the Maine Department of Transportation, Augusta, Maine 04333 and endorsed on the wrapper “Bids for **Highway Reconstruction & Mill and Fill** in the city of **Augusta**” will be received from contractors at the Reception Desk, MaineDOT Building, Capitol Street, Augusta, Maine, until 11:00 o’clock A.M. (prevailing time) on **May 13, 2026**, and at that time and place, publicly opened and read. Bids will be accepted from all bidders. The lowest responsive bidder must have completed, or successfully complete, a **Highway Construction, Paving**, or project specific prequalification to be considered for the award of this contract. **We now accept electronic bids for bid packages posted on the bidx.com website. Electronic bids do not have to be accompanied by paper bids. Please note: The Department will accept a facsimile of the bid bond; however, the original bid bond must then be received at the MDOT Contract Section within 72 hours of the bid opening. Until further notice, dual bids (one paper, one electronic) will be accepted, with the paper copy taking precedence.**

Description: Maine Federal Aid Project Nos. 2575100 & 2835600 WINs 025751.00 & 028356.00

Location: In Kennebec County,

WIN 025751.00 is located in Augusta on Cony Street West, Memorial Drive, Stone Street, and Cony Street East as they approach Cony Circle, as well as Bangor Street from Cony Circle to North Belfast Avenue.

WIN 028356.00 is located in Augusta on US Route 202 (North Belfast Avenue).

Outline of Work: Highway Reconstruction, Mill and Fill and other incidental work.

For general information regarding Bidding and Contracting procedures, contact George Macdougall at (207) 624-3410. Our webpage at <http://www.maine.gov/mdot/contractors/> contains a copy of the Schedule of Items, Plan Holders List, written portions of bid amendments, drawings, bid results and an electronic form for RFI submittal. For Project-specific information fax all questions to **Ernie Martin** at (207) 624-3431, use electronic RFI form or email questions to RFI-Contracts.MDOT@maine.gov, project name and identification number should be in the subject line. Questions received after 12:00 noon of Monday (or if that Monday is a state holiday, Friday) prior to bid date will not be answered. Bidders shall not contact any other Departmental staff for clarification of Contract provisions, and the Department will not be responsible for any interpretations so obtained. TTY users call Maine Relay 711.

Bid Documents, specifications and bid forms can be viewed and obtained digitally at no cost at <http://www.maine.gov/mdot/contractors/>. They may be purchased from the Department between the hours of 7:00 a.m. to 3:30 p.m. by cash, credit card (Visa/Mastercard) or check payable to Treasurer, State of Maine sent to Maine Department of Transportation, Attn.: Mailroom, 24 Child Street, Augusta, Maine 04333-0016. They also may be purchased by telephone at (207) 624-3536 between the hours of 7:00 a.m. to 3:30 p.m. Full size plans **\$113.00 (\$120.00 by mail)**. Half size plans **\$56.50 (\$60.25 by mail)**, Bid Book \$10 (\$13 by mail), Single Sheets \$2, payment in advance, all non-refundable.

Each Bid must be made upon blank forms provided by the Department and must be accompanied by a bid bond at 5% of the bid amount or an official bank check, cashier’s check, certified check, certificate of deposit, or United States postal money order in the amount of 5% of the bid amount, payable to Treasurer, State of Maine as a Bid guarantee. A Contract Performance Surety Bond and a Contract Payment Surety Bond, each in the amount of 100 percent of the Contract price, will be required of the successful Bidder.

This Contract is subject to all applicable Federal Laws. This contract is subject to compliance with the Disadvantaged Business Enterprise program requirements as set forth by the Maine Department of Transportation.

All work shall be governed by *State of Maine, Department of Transportation, Standard Specifications, March 2020 Edition*, price \$10 [\$15 by mail], and *Standard Details, March 2020 Edition*, price \$10 [\$15 by mail]. They also may be purchased by telephone at (207) 624-3536 between the hours of 7:00 a.m. to 3:30 p.m. *Standard Detail* updates can be found at <http://www.maine.gov/mdot/contractors/publications/>.

The right is hereby reserved to the MaineDOT to reject any or all bids.

Augusta, Maine
April 22, 2026

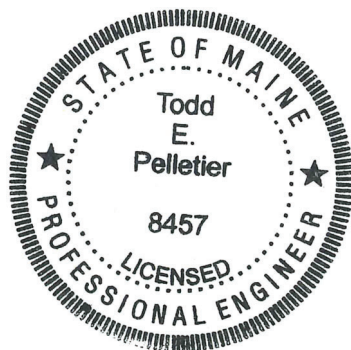

A handwritten signature in black ink, appearing to read "T. Pelletier".

TODD E PELLETTIER P. E.
DEPUTY CHIEF ENGINEER

NOTICE

All bids for Federal Projects **shall** be accompanied by the DBE Proposed Utilization form. If you are submitting an electronic bid, the DBE Utilization Form may be faxed to 207-624-3431. Failure to submit the form with the bid will be considered a curable defect.

SPECIAL PROVISION 102.7.3
ACKNOWLEDGMENT OF BID AMENDMENTS

With this form, the Bidder acknowledges its responsibility to check for all Amendments to the Bid Package. For each Project under Advertisement, Amendments are located at <http://www.maine.gov/mdot/contractors/> . It is the responsibility of the Bidder to determine if there are Amendments to the Project, to download them, to incorporate them into their Bid Package, and to reference the Amendment number and the date on the form below. The Maine DOT will not post Bid Amendments any later than noon the day before Bid opening without individually notifying all the planholders.

Amendment Number	Date

The Contractor, for itself, its successors and assigns, hereby acknowledges that it has received all of the above referenced Amendments to the Bid Package.

CONTRACTOR

_____ Date

_____ Signature of authorized representative

_____ (Name and Title Printed)

Maine Department of Transportation

Proposal Schedule of Items

Proposal ID: 025751.00

Project(s): 025751.00, 028356.00

SECTION: 1 HIGHWAY ITEMS

Alt Set ID: Alt Mbr ID:

Contractor: _____

Proposal Line Number	Item ID Description	Approximate Quantity and Units	Unit Price		Bid Amount	
			Dollars	Cents	Dollars	Cents
0010	201.23 REMOVING SINGLE TREE TOP ONLY	4.000 EA	_____	 _____	_____	 _____
0020	201.24 REMOVING STUMP	6.000 EA	_____	 _____	_____	 _____
0030	202.15 REMOVING EXISTING MANHOLE OR CATCH BASIN	4.000 EA	_____	 _____	_____	 _____
0040	202.202 REMOVING PAVEMENT SURFACE	49,300.000 SY	_____	 _____	_____	 _____
0050	202.203 PAVEMENT BUTT JOINTS	1,930.000 SY	_____	 _____	_____	 _____
0060	203.20 COMMON EXCAVATION	4,500.000 CY	_____	 _____	_____	 _____
0070	203.2312 HEALTH AND SAFETY PLAN	LUMP SUM		 LUMP SUM		 _____
0080	203.2333 DISPOSAL TREATMENT OF SPECIAL EXCAVATION	10.000 T	_____	 _____	_____	 _____
0090	304.10 AGGREGATE SUBBASE COURSE - GRAVEL	3,075.000 CY	_____	 _____	_____	 _____
0100	403.2081 12.5 MM POLYMER MODIFIED HOT MIX ASPHALT	4,200.000 T	_____	 _____	_____	 _____
0110	403.209 HOT MIX ASPHALT 9.5 MM (SIDEWALKS, DRIVES, INCIDENTALS)	855.000 T	_____	 _____	_____	 _____
0120	403.2111 9.5 MM POLYMER MODIFIED HMA (SHIM)	2,290.000 T	_____	 _____	_____	 _____

Maine Department of Transportation

Proposal Schedule of Items

Proposal ID: 025751.00

Project(s): 025751.00, 028356.00

SECTION: 1 HIGHWAY ITEMS

Alt Set ID: Alt Mbr ID:

Contractor: _____

Proposal Line Number	Item ID Description	Approximate Quantity and Units	Unit Price		Bid Amount	
			Dollars	Cents	Dollars	Cents
0130	403.2131 12.5 MM POLYMER MODIFIED HMA BASE	3,280.000 T	_____	 _____	_____	 _____
0140	409.15 BITUMINOUS TACK COAT - APPLIED	4,065.000 G	_____	 _____	_____	 _____
0150	424.22 ASPHALT RUBBER CRACK SEALER TYPE 2, APPLIED	2,400.000 LB	_____	 _____	_____	 _____
0160	424.38 CRACK REPAIR - HOT POUR MASTIC	4,300.000 LB	_____	 _____	_____	 _____
0170	502.342 STRUCTURAL CONCRETE ROADWAY TRUCK APRON	24.000 CY	_____	 _____	_____	 _____
0180	602.30 FLOWABLE CONCRETE FILL	5.000 CY	_____	 _____	_____	 _____
0190	603.155 12 INCH REINFORCED CONCRETE PIPE CLASS III	115.000 LF	_____	 _____	_____	 _____
0200	603.159 12 INCH CULVERT PIPE OPTION III	122.000 LF	_____	 _____	_____	 _____
0210	603.165 15 INCH REINFORCED CONCRETE PIPE CLASS III	105.000 LF	_____	 _____	_____	 _____
0220	603.169 15 INCH CULVERT PIPE OPTION III	71.000 LF	_____	 _____	_____	 _____
0230	603.205 30 INCH REINFORCED CONCRETE PIPE CLASS III	140.000 LF	_____	 _____	_____	 _____
0240	604.072 CATCH BASIN TYPE A1-C	20.000 EA	_____	 _____	_____	 _____

Maine Department of Transportation

Proposal Schedule of Items

Proposal ID: 025751.00

Project(s): 025751.00, 028356.00

SECTION: 1 HIGHWAY ITEMS

Alt Set ID: Alt Mbr ID:

Contractor: _____

Proposal Line Number	Item ID Description	Approximate Quantity and Units	Unit Price		Bid Amount	
			Dollars	Cents	Dollars	Cents
0250	604.077 72 INCH CATCH BASIN TYPE A1-C	2.625 EA	_____	 _____	_____	 _____
0260	604.09 CATCH BASIN TYPE B1	2.625 EA	_____	 _____	_____	 _____
0270	604.092 CATCH BASIN TYPE B1-C	6.000 EA	_____	 _____	_____	 _____
0280	604.093 60 INCH CATCH BASIN TYPE B1	1.375 EA	_____	 _____	_____	 _____
0290	604.094 72 INCH CATCH BASIN TYPE B1	1.375 EA	_____	 _____	_____	 _____
0300	604.161 ALTERING CATCH BASIN	1.000 EA	_____	 _____	_____	 _____
0310	604.18 ADJUSTING MANHOLE OR CATCH BASIN TO GRADE	64.000 EA	_____	 _____	_____	 _____
0320	604.247 CATCH BASIN TYPE F5-C	8.000 EA	_____	 _____	_____	 _____
0330	604.249 CATCH BASIN TYPE F6-C	4.000 EA	_____	 _____	_____	 _____
0340	605.09 6 INCH UNDERDRAIN TYPE B	57.000 LF	_____	 _____	_____	 _____
0350	605.11 12 INCH UNDERDRAIN TYPE C	930.000 LF	_____	 _____	_____	 _____
0360	605.13 18 INCH UNDERDRAIN TYPE C	193.000 LF	_____	 _____	_____	 _____
0370	605.15 24 INCH UNDERDRAIN TYPE C	137.000 LF	_____	 _____	_____	 _____

Maine Department of Transportation

Proposal Schedule of Items

Proposal ID: 025751.00

Project(s): 025751.00, 028356.00

SECTION: 1 HIGHWAY ITEMS

Alt Set ID: Alt Mbr ID:

Contractor: _____

Proposal Line Number	Item ID Description	Approximate Quantity and Units	Unit Price		Bid Amount	
			Dollars	Cents	Dollars	Cents
0380	605.17 30 INCH UNDERDRAIN TYPE C	600.000 LF	_____	 _____	_____	 _____
0390	607.22 CEDAR RAIL FENCE	96.000 LF	_____	 _____	_____	 _____
0400	607.24 REMOVE AND RESET FENCE	10.000 LF	_____	 _____	_____	 _____
0410	608.08 REINFORCED CONCRETE SIDEWALK	5.000 SY	_____	 _____	_____	 _____
0420	608.10 BRICK SIDEWALK, REMOVE AND REBUILD	43.000 SY	_____	 _____	_____	 _____
0430	608.26 CURB RAMP DETECTABLE WARNING FIELD	1,015.000 SF	_____	 _____	_____	 _____
0440	608.46 REGRADE SIDEWALK	50.000 SY	_____	 _____	_____	 _____
0450	609.11 VERTICAL CURB TYPE 1	630.000 LF	_____	 _____	_____	 _____
0460	609.1111 SPECIAL GRANITE CURB - 39"	150.000 LF	_____	 _____	_____	 _____
0470	609.12 VERTICAL CURB TYPE 1 - CIRCULAR	280.000 LF	_____	 _____	_____	 _____
0480	609.221 TERMINAL CURB TYPE 1	1,450.000 LF	_____	 _____	_____	 _____
0490	609.222 TERMINAL CURB TYPE 1 - CIRCULAR	310.000 LF	_____	 _____	_____	 _____
0500	609.31 CURB TYPE 3	445.000 LF	_____	 _____	_____	 _____

Maine Department of Transportation

Proposal Schedule of Items

Proposal ID: 025751.00

Project(s): 025751.00, 028356.00

SECTION: 1 HIGHWAY ITEMS

Alt Set ID: Alt Mbr ID:

Contractor: _____

Proposal Line Number	Item ID Description	Approximate Quantity and Units	Unit Price		Bid Amount	
			Dollars	Cents	Dollars	Cents
0510	609.34 CURB TYPE 5	2,780.000 LF	_____	 _____	_____	 _____
0520	609.341 CURB TYPE 5 - TRUCK APRON	280.000 LF	_____	 _____	_____	 _____
0530	609.35 CURB TYPE 5 - CIRCULAR	350.000 LF	_____	 _____	_____	 _____
0540	609.38 RESET CURB TYPE 1	1,575.000 LF	_____	 _____	_____	 _____
0550	610.08 PLAIN RIPRAP	12.000 CY	_____	 _____	_____	 _____
0560	613.319 EROSION CONTROL BLANKET	230.000 SY	_____	 _____	_____	 _____
0570	615.07 LOAM	575.000 CY	_____	 _____	_____	 _____
0580	618.13 SEEDING METHOD NUMBER 1	47.000 UN	_____	 _____	_____	 _____
0590	619.12 MULCH	47.000 UN	_____	 _____	_____	 _____
0600	620.58 EROSION CONTROL GEOTEXTILE	40.000 SY	_____	 _____	_____	 _____
0610	626.11 PRECAST CONCRETE JUNCTION BOX	44.000 EA	_____	 _____	_____	 _____
0620	626.21 METALLIC CONDUIT	20.000 LF	_____	 _____	_____	 _____
0630	626.22 NON-METALLIC CONDUIT	5,500.000 LF	_____	 _____	_____	 _____

Maine Department of Transportation

Proposal Schedule of Items

Proposal ID: 025751.00

Project(s): 025751.00, 028356.00

SECTION: 1 HIGHWAY ITEMS

Alt Set ID: Alt Mbr ID:

Contractor: _____

Proposal Line Number	Item ID Description	Approximate Quantity and Units	Unit Price		Bid Amount	
			Dollars	Cents	Dollars	Cents
0640	626.36 REMOVE OR MODIFY CONCRETE FOUNDATION	9.000 EA	_____	 _____	_____	 _____
0650	626.421 24 INCH DIAMETER FOUNDATION	490.000 LF	_____	 _____	_____	 _____
0660	627.733 4" WHITE OR YELLOW PAINTED PAVEMENT MARKING LINE	36,230.000 LF	_____	 _____	_____	 _____
0670	627.75 WHITE OR YELLOW PAVEMENT & CURB MARKING	6,925.000 SF	_____	 _____	_____	 _____
0680	627.78 TEMPORARY 4 INCH PAINTED PAVEMENT MARKING LINE, WHITE OR YELLOW	49,860.000 LF	_____	 _____	_____	 _____
0690	627.941 PREFORMED THERMOPLASTIC PAVEMENT MARKING	2,300.000 SF	_____	 _____	_____	 _____
0700	629.05 HAND LABOR, STRAIGHT TIME	66.000 HR	_____	 _____	_____	 _____
0710	631.12 ALL PURPOSE EXCAVATOR (INCLUDING OPERATOR)	55.000 HR	_____	 _____	_____	 _____
0720	631.172 TRUCK - LARGE (INCLUDING OPERATOR)	96.000 HR	_____	 _____	_____	 _____
0730	631.20 STUMP CHIPPER (INCLUDING OPERATOR)	20.000 HR	_____	 _____	_____	 _____
0740	631.32 CULVERT CLEANER (INCLUDING OPERATOR)	20.000 HR	_____	 _____	_____	 _____

Maine Department of Transportation

Proposal Schedule of Items

Proposal ID: 025751.00

Project(s): 025751.00, 028356.00

SECTION: 1 HIGHWAY ITEMS

Alt Set ID: Alt Mbr ID:

Contractor: _____

Proposal Line Number	Item ID Description	Approximate Quantity and Units	Unit Price		Bid Amount	
			Dollars	Cents	Dollars	Cents
0750	634.16 HIGHWAY LIGHTING	LUMP SUM	LUMP	SUM	_____	_____
0760	634.210 CONVENTIONAL LIGHT STANDARD	22.000 EA	_____	_____	_____	_____
0770	639.18 FIELD OFFICE TYPE A	1.000 EA	_____	_____	_____	_____
0780	643.62 RECTANGULAR RAPID FLASHING BEACON - REMOVE & STACK	1.000 EA	_____	_____	_____	_____
0790	643.621 RECTANGULAR RAPID FLASHING BEACON ASSEMBLY HARD WIRED	14.000 EA	_____	_____	_____	_____
0800	643.71 TRAFFIC SIGNAL MODIFICATION BANGOR ST. & NORTH BELFAST AVE	LUMP SUM	LUMP	SUM	_____	_____
0810	643.71 TRAFFIC SIGNAL MODIFICATION BANGOR ST. & QUIMBY ST.	LUMP SUM	LUMP	SUM	_____	_____
0820	643.92 PEDESTAL POLE	7.000 EA	_____	_____	_____	_____
0830	643.922 REMOVE AND RESET PEDESTAL POLE	3.000 EA	_____	_____	_____	_____
0840	645.103 DEMOUNT GUIDE SIGN	7.000 EA	_____	_____	_____	_____
0850	645.106 DEMOUNT REGULATORY, WARNING, CONFIRMATION AND ROUTE MARKER ASSEMBLY SIGN	72.000 EA	_____	_____	_____	_____

Maine Department of Transportation

Proposal Schedule of Items

Proposal ID: 025751.00

Project(s): 025751.00, 028356.00

SECTION: 1 HIGHWAY ITEMS

Alt Set ID: Alt Mbr ID:

Contractor: _____

Proposal Line Number	Item ID Description	Approximate Quantity and Units	Unit Price		Bid Amount	
			Dollars	Cents	Dollars	Cents
0860	645.113 REINSTALL GUIDE SIGN	7.000 EA	_____	 _____	_____	 _____
0870	645.116 REINSTALL REGULATORY, WARNING, CONFIRMATION AND ROUTE MARKER ASSEMBLY SIGN	63.000 EA	_____	 _____	_____	 _____
0880	645.251 ROADSIDE GUIDE SIGNS, TYPE I	136.000 SF	_____	 _____	_____	 _____
0890	645.292 REGULATORY, WARNING, CONFIRMATION AND ROUTE MARKER ASSEMBLY SIGNS TYPE II	470.000 SF	_____	 _____	_____	 _____
0900	652.312 TYPE III BARRICADE	10.000 EA	_____	 _____	_____	 _____
0910	652.33 DRUM	200.000 EA	_____	 _____	_____	 _____
0920	652.34 CONE	250.000 EA	_____	 _____	_____	 _____
0930	652.35 CONSTRUCTION SIGNS	2,450.000 SF	_____	 _____	_____	 _____
0940	652.36 MAINTENANCE OF TRAFFIC CONTROL DEVICES	348.000 CD	_____	 _____	_____	 _____
0950	652.38 FLAGGER	10,000.000 HR	_____	 _____	_____	 _____
0960	652.41 PORTABLE CHANGEABLE MESSAGE SIGN	7.000 EA	_____	 _____	_____	 _____

Maine Department of Transportation

Proposal Schedule of Items

Proposal ID: 025751.00

Project(s): 025751.00, 028356.00

SECTION: 1 HIGHWAY ITEMS

Alt Set ID: Alt Mbr ID:

Contractor: _____

Proposal Line Number	Item ID Description	Approximate Quantity and Units	Unit Price		Bid Amount	
			Dollars	Cents	Dollars	Cents
0970	656.75 TEMPORARY SOIL EROSION AND WATER POLLUTION CONTROL	LUMP SUM	LUMP	SUM	_____	_____
0980	658.20 ACRYLIC LATEX COLOR FINISH, GREEN	480.000 SY	_____	_____	_____	_____
0990	659.10 MOBILIZATION	LUMP SUM	LUMP	SUM	_____	_____
1000	803.01 TEST PITS	6.000 EA	_____	_____	_____	_____
1010	890.01 SPECIAL WORK NUMBER 1 CMP UNDERGROUND RELOCATION	LUMP SUM	LUMP	SUM	_____	_____
Section: 1			Total:		_____	_____
			Total Bid:		_____	_____

CONTRACT AGREEMENT, OFFER & AWARD

AGREEMENT made on the date last signed below, by and between the State of Maine, acting through and by its Department of Transportation (Department), an agency of state government with its principal administrative offices located at Child Street, Augusta, Maine, with a mailing address at 16 State House Station, Augusta, Maine 04333-0016, and

_____ a corporation or other legal entity organized under the laws of the State of _____, with its principal place of business located at _____

The Department and the Contractor, in consideration of the mutual promises set forth in this Agreement (the "Contract"), hereby agree as follows:

A. **The Work.**

The Contractor agrees to complete all Work as specified or indicated in the Contract including Extra Work in conformity with the Contract, **WIN 025751.00** for **Highway Reconstruction & WIN 028356.00** for **Mill and Fill** in the city of **Augusta**, County of **Kennebec, Maine**. The Work includes construction, maintenance during construction, warranty as provided in the Contract, and other incidental work.

The Contractor shall be responsible for furnishing all supervision, labor, equipment, tools supplies, permanent materials and temporary materials required to perform the Work; performing construction quality control including inspection, testing and documentation; providing all required documentation at the conclusion of the project; warranting its work; and performing all other work indicated in the Contract.

The Department shall have the right to alter the nature and extent of the Work as provided in the Contract. Payment shall be made as provided in the same.

B. **Time.**

The Contractor agrees to complete all Work, except warranty work, on or before **November 13, 2027**. Further, the Department may deduct from moneys otherwise due the Contractor, not as a penalty, but as Liquidated Damages in accordance with Sections 107.7 and 107.8 of the *State of Maine Department of Transportation Standard Specifications, March 2020 Edition* and related Special Provisions.

C. Price.

The quantities given in the Schedule of Items of the Bid Package will be used as the basis for determining the original Contract amount and for determining the amounts of the required Performance Surety Bond and Payment Surety Bond, and that the amount of this offer is _____

\$ _____ Performance Bond and Payment Bond each being 100% of the amount of this Contract.

D. Contract.

This Contract, which may be amended, modified, or supplemented in writing only, consists of the Contract documents as defined in the Plans, *Standard Specifications, March 2020 Edition, Standard Details March 2020 Edition* as updated through advertisement, Supplemental Specifications, Special Provisions, Contract Agreement; and Contract Bonds. It is agreed and understood that this Contract will be governed by the documents listed above.

E. Certifications.

By signing below, the Contractor hereby certifies that to the best of the Contractor's knowledge and belief:

1. All of the statements, representations, covenants, and/or certifications required or set forth in the Bid and the Bid Documents, including those in the Federal Contract Provisions Supplement, and the Contract are still complete and accurate as of the date of this Agreement.
2. The Contractor knows of no legal, contractual, or financial impediment to entering into this Contract.
3. The person signing below is legally authorized by the Contractor to sign this Contract on behalf of the Contractor and to legally bind the Contractor to the terms of the Contract.

F. Offer.

The undersigned, having carefully examined the site of work, the Plans, *Standard Specifications March 2020 Edition*, *Standard Details March 2020 Edition* as updated through advertisement, Supplemental Specifications, Special Provisions, Contract Agreement; and Contract Bonds contained herein for construction of:

**WIN 025751.00 for Highway Reconstruction &
WIN 028356.00 for Mill and Fill - in the city of Augusta**

State of Maine, on which bids will be received until the time specified in the “Notice to Contractors” do(es) hereby bid and offer to enter into this contract to supply all the materials, tools, equipment and labor to construct the whole of the Work in strict accordance with the terms and conditions of this Contract at the unit prices in the attached “Schedule of Items.”

The Offeror agrees to perform the work required at the price specified above and in accordance with the bids provided in the attached “Schedule of Items” in strict accordance with the terms of this solicitation, and to provide the appropriate insurance and bonds if this offer is accepted by the Government in writing.

As Offeror also agrees:

First: To do any extra work, not covered by the attached “Schedule of Items,” which may be ordered by the Resident, and to accept as full compensation the amount determined upon a “Force Account” basis as provided in the *Standard Specifications, March 2020 Edition*, and as addressed in the contract documents.

Second: That the bid bond at 5% of the bid amount or the official bank check, cashier’s check, certificate of deposit or U. S. Postal Money Order in the amount given in the “Notice to Contractors”, payable to the Treasurer of the State of Maine and accompanying this bid, shall be forfeited, as liquidated damages, if in case this bid is accepted, and the undersigned shall fail to abide by the terms and conditions of the offer and fail to furnish satisfactory insurance and Contract bonds under the conditions stipulated in the Specifications within 15 days of notice of intent to award the contract.

Third: To begin the Work as stated in Section 107.2 of the *Standard Specifications March 2020 Edition* and complete the Work within the time limits given in the Special Provisions of this Contract.

Fourth: The Contractor will be bound to the Disadvantaged Business Enterprise (DBE) Requirements contained in the attached Notice (Additional Instructions to Bidders) and submit a completed Contractor’s Disadvantaged Business Enterprise Utilization Plan with their bid.

Fifth: That this offer shall remain open for 30 calendar days after the date of opening of bids.

Sixth: The Bidder hereby certifies, to the best of its knowledge and belief that: the Bidder has not, either directly or indirectly, entered into any agreement, participated in any collusion, or otherwise taken any action in restraint of competitive bidding in connection with its bid, and its subsequent contract with the Department.

IN WITNESS WHEREOF, the Contractor, for itself, its successors and assigns, hereby execute two duplicate originals of this Agreement and thereby binds itself to all covenants, terms, and obligations contained in the Contract Documents.

CONTRACTOR

Date

(Signature of Legally Authorized Representative
of the Contractor)

Witness

(Name and Title Printed)

G. Award.

Your offer is hereby accepted.
documents referenced herein.

This award consummates the Contract, and the

MAINE DEPARTMENT OF TRANSPORTATION

Date

By: Dale F. Doughty, Commissioner

Witness

CONTRACT AGREEMENT, OFFER & AWARD

AGREEMENT made on the date last signed below, by and between the State of Maine, acting through and by its Department of Transportation (Department), an agency of state government with its principal administrative offices located at Child Street, Augusta, Maine, with a mailing address at 16 State House Station, Augusta, Maine 04333-0016, and

_____ a corporation or other legal entity organized under the laws of the State of _____, with its principal place of business located at _____

The Department and the Contractor, in consideration of the mutual promises set forth in this Agreement (the "Contract"), hereby agree as follows:

A. The Work.

The Contractor agrees to complete all Work as specified or indicated in the Contract including Extra Work in conformity with the Contract, **WIN 025751.00** for **Highway Reconstruction & WIN 028356.00** for **Mill and Fill** in the city of **Augusta**, County of **Kennebec, Maine**. The Work includes construction, maintenance during construction, warranty as provided in the Contract, and other incidental work.

The Contractor shall be responsible for furnishing all supervision, labor, equipment, tools supplies, permanent materials and temporary materials required to perform the Work; performing construction quality control including inspection, testing and documentation; providing all required documentation at the conclusion of the project; warranting its work; and performing all other work indicated in the Contract.

The Department shall have the right to alter the nature and extent of the Work as provided in the Contract. Payment shall be made as provided in the same.

B. Time.

The Contractor agrees to complete all Work, except warranty work, on or before **November 13, 2027**. Further, the Department may deduct from moneys otherwise due the Contractor, not as a penalty, but as Liquidated Damages in accordance with Sections 107.7 and 107.8 of the *State of Maine Department of Transportation Standard Specifications, March 2020 Edition* and related Special Provisions.

C. Price.

The quantities given in the Schedule of Items of the Bid Package will be used as the basis for determining the original Contract amount and for determining the amounts of the required Performance Surety Bond and Payment Surety Bond, and that the amount of this offer is _____

\$ _____ Performance Bond and Payment Bond each being 100% of the amount of this Contract.

D. Contract.

This Contract, which may be amended, modified, or supplemented in writing only, consists of the Contract documents as defined in the Plans, *Standard Specifications, March 2020 Edition, Standard Details March 2020 Edition* as updated through advertisement, Supplemental Specifications, Special Provisions, Contract Agreement; and Contract Bonds. It is agreed and understood that this Contract will be governed by the documents listed above.

E. Certifications.

By signing below, the Contractor hereby certifies that to the best of the Contractor's knowledge and belief:

1. All of the statements, representations, covenants, and/or certifications required or set forth in the Bid and the Bid Documents, including those in the Federal Contract Provisions Supplement, and the Contract are still complete and accurate as of the date of this Agreement.
2. The Contractor knows of no legal, contractual, or financial impediment to entering into this Contract.
3. The person signing below is legally authorized by the Contractor to sign this Contract on behalf of the Contractor and to legally bind the Contractor to the terms of the Contract.

F. Offer.

The undersigned, having carefully examined the site of work, the Plans, *Standard Specifications March 2020 Edition*, *Standard Details March 2020 Edition* as updated through advertisement, Supplemental Specifications, Special Provisions, Contract Agreement; and Contract Bonds contained herein for construction of:

**WIN 025751.00 for Highway Reconstruction &
WIN 028356.00 for Mill and Fill - in the city of Augusta**

State of Maine, on which bids will be received until the time specified in the “Notice to Contractors” do(es) hereby bid and offer to enter into this contract to supply all the materials, tools, equipment and labor to construct the whole of the Work in strict accordance with the terms and conditions of this Contract at the unit prices in the attached “Schedule of Items.”

The Offeror agrees to perform the work required at the price specified above and in accordance with the bids provided in the attached “Schedule of Items” in strict accordance with the terms of this solicitation, and to provide the appropriate insurance and bonds if this offer is accepted by the Government in writing.

As Offeror also agrees:

First: To do any extra work, not covered by the attached “Schedule of Items,” which may be ordered by the Resident, and to accept as full compensation the amount determined upon a “Force Account” basis as provided in the *Standard Specifications, March 2020 Edition*, and as addressed in the contract documents.

Second: That the bid bond at 5% of the bid amount or the official bank check, cashier’s check, certificate of deposit or U. S. Postal Money Order in the amount given in the “Notice to Contractors”, payable to the Treasurer of the State of Maine and accompanying this bid, shall be forfeited, as liquidated damages, if in case this bid is accepted, and the undersigned shall fail to abide by the terms and conditions of the offer and fail to furnish satisfactory insurance and Contract bonds under the conditions stipulated in the Specifications within 15 days of notice of intent to award the contract.

Third: To begin the Work as stated in Section 107.2 of the *Standard Specifications March 2020 Edition* and complete the Work within the time limits given in the Special Provisions of this Contract.

Fourth: The Contractor will be bound to the Disadvantaged Business Enterprise (DBE) Requirements contained in the attached Notice (Additional Instructions to Bidders) and submit a completed Contractor’s Disadvantaged Business Enterprise Utilization Plan with their bid.

Fifth: That this offer shall remain open for 30 calendar days after the date of opening of bids.

Sixth: The Bidder hereby certifies, to the best of its knowledge and belief that: the Bidder has not, either directly or indirectly, entered into any agreement, participated in any collusion, or otherwise taken any action in restraint of competitive bidding in connection with its bid, and its subsequent contract with the Department.

IN WITNESS WHEREOF, the Contractor, for itself, its successors and assigns, hereby execute two duplicate originals of this Agreement and thereby binds itself to all covenants, terms, and obligations contained in the Contract Documents.

CONTRACTOR

Date

(Signature of Legally Authorized Representative
of the Contractor)

Witness

(Name and Title Printed)

G. Award.

Your offer is hereby accepted.
documents referenced herein.

This award consummates the Contract, and the

MAINE DEPARTMENT OF TRANSPORTATION

Date

By: Dale F. Doughty, Commissioner

Witness

CONTRACT AGREEMENT, OFFER & AWARD

AGREEMENT made on the date last signed below, by and between the State of Maine, acting through and by its Department of Transportation (Department), an agency of state government with its principal administrative offices located at Child Street Augusta, Maine, with a mailing address at 16 State House Station, Augusta, Maine 04333-0016, and (Name of the firm bidding the job) a corporation or other legal entity organized under the laws of the State of Maine, with its principal place of business located at (address of the firm bidding the job)

The Department and the Contractor, in consideration of the mutual promises set forth in this Agreement (the "Contract"), hereby agree as follows:

A. The Work.

The Contractor agrees to complete all Work as specified or indicated in the Contract including Extra Work in conformity with the Contract, PIN No.0112345.00, for the **Hot Mix Asphalt Overlay** in the town/city of **South Nowhere**, County of **Washington**, Maine. The Work includes construction, maintenance during construction, warranty as provided in the Contract, and other incidental work.

The Contractor shall be responsible for furnishing all supervision, labor, equipment, tools supplies, permanent materials and temporary materials required to perform the Work including construction quality control including inspection, testing and documentation, all required documentation at the conclusion of the project, warranting its work and performing all other work indicated in the Contract.

The Department shall have the right to alter the nature and extent of the Work as provided in the Contract; payment to be made as provided in the same.

B. Time.

The Contractor agrees to complete all Work, except warranty work, on or before **November 15, 2006**. Further, the Department may deduct from moneys otherwise due the Contractor, not as a penalty, but as Liquidated Damages in accordance with Sections 107.7 and 107.8 of the *State of Maine Department of Transportation Standard Specifications, March 2020 Edition* and related Special Provisions.

C. Price.

The quantities given in the Schedule of Items of the Bid Package will be used as the basis for determining the original Contract amount and for determining the amounts of the required Performance Surety Bond and Payment Surety Bond, and that the amount of this offer is (Place bid here in alphabetical form such as One Hundred and Two dollars and 10 cents)
\$ (repeat bid here in numerical terms, such as \$102.10) Performance Bond and Payment Bond each being 100% of the amount of this Contract.

D. Contract.

This Contract, which may be amended, modified, or supplemented in writing only, consists of the Contract documents as defined in the Plans, *Standard Specifications, March 2020 Edition, Standard Details March 2020 Edition*, Supplemental Specifications, Special Provisions, Contract Agreement; and Contract Bonds. It is agreed and understood that this Contract will be governed by the documents listed above.

E. Certifications.

By signing below, the Contractor hereby certifies that to the best of the Contractor's knowledge and belief:

1. All of the statements, representations, covenants, and/or certifications required or set forth in the Bid and the Bid Documents, including those in Appendix A to Division 100 of the *Standard Specifications March 2020 Edition* (Federal Contract Provisions Supplement), and the Contract are still complete and accurate as of the date of this Agreement.
2. The Contractor knows of no legal, contractual, or financial impediment to entering into this Contract.
3. The person signing below is legally authorized by the Contractor to sign this Contract on behalf of the Contractor and to legally bind the Contractor to the terms of the Contract.

F. Offer.

The undersigned, having carefully examined the site of work, the Plans, *Standard Specifications, March 2020 Edition, Standard Details March 2020 Edition*, Supplemental Specifications, Special Provisions, Contract Agreement; and Contract Bonds contained herein for construction of:

PIN 012345.00 South Nowhere, Hot Mix Asphalt Overlay

State of Maine, on which bids will be received until the time specified in the “Notice to Contractors” do(es) hereby bid and offer to enter into this contract to supply all the materials, tools, equipment and labor to construct the whole of the Work in strict accordance with the terms and conditions of this Contract at the unit prices in the attached “Schedule of Items.”

The Offeror agrees to perform the work required at the price specified above and in accordance with the bids provided in the attached “Schedule of Items” in strict accordance with the terms of this solicitation, and to provide the appropriate insurance and bonds if this offer is accepted by the Government in writing.

As Offeror also agrees:

First: To do any extra work, not covered by the attached “Schedule of Items,” which may be ordered by the Resident, and to accept as full compensation the amount determined upon a “Force Account” basis as provided in the *Standard Specifications, March 2020 Edition*, and as addressed in the contract documents.

Second: That the bid bond at 5% of the bid amount or the official bank check, cashier’s check, certificate of deposit or U. S. Postal Money Order in the amount given in the “Notice to Contractors”, payable to the Treasurer of the State of Maine and accompanying this bid, shall be forfeited, as liquidated damages, if in case this bid is accepted, and the undersigned shall fail to abide by the terms and conditions of the offer and fail to furnish satisfactory insurance and Contract bonds under the conditions stipulated in the Specifications within 15 days of notice of intent to award the contract.

Third: To begin the Work as stated in Section 107.2 of the *Standard Specifications March 2020 Edition* and complete the Work within the time limits given in the Special Provisions of this Contract.

Fourth: The Contractor will be bound to the Disadvantaged Business Enterprise (DBE) Requirements contained in the attached Notice (Additional Instructions to Bidders) and submit a completed Contractor’s Disadvantaged Business Enterprise Utilization Plan with their bid.

Fifth: That this offer shall remain open for 30 calendar days after the date of opening of bids.

Sixth: The Bidder hereby certifies, to the best of its knowledge and belief that: the Bidder has not, either directly or indirectly, entered into any agreement, participated in any collusion, or otherwise taken any action in restraint of competitive bidding in connection with its bid, and its subsequent contract with the Department.

IN WITNESS WHEREOF, the Contractor, for itself, its successors and assigns, hereby execute two duplicate originals of this Agreement and thereby binds itself to all covenants, terms, and obligations contained in the Contract Documents.

CONTRACTOR

(Sign Here)
(Signature of Legally Authorized Representative
of the Contractor)

(Print Name Here)
(Name and Title Printed)

(Witness Sign Here)
Witness

Date

G. Award.

Your offer is hereby accepted.
documents referenced herein.

This award consummates the Contract, and the

MAINE DEPARTMENT OF TRANSPORTATION

Date

By: Dale F. Doughty, Commissioner

(Witness)

BOND # _____

CONTRACT PERFORMANCE BOND
(Surety Company Form)

KNOW ALL MEN BY THESE PRESENTS: That _____
_____ in the State of _____, as principal,
and.....
a corporation duly organized under the laws of the State of and having a
usual place of business
as Surety, are held and firmly bound unto the Treasurer of the State of Maine in the sum
of _____ and 00/100 Dollars (\$ _____),
to be paid said Treasurer of the State of Maine or his successors in office, for which
payment well and truly to be made, Principal and Surety bind themselves, their heirs,
executors and administrators, successors and assigns, jointly and severally by these
presents.

The condition of this obligation is such that if the Principal designated as Contractor in
the Contract to construct Project Number _____ in the Municipality of
_____ promptly and faithfully performs the Contract, then this
obligation shall be null and void; otherwise it shall remain in full force and effect.

The Surety hereby waives notice of any alteration or extension of time made by the State
of Maine.

Signed and sealed this day of, 20.....

WITNESSES:

SIGNATURES:

CONTRACTOR:

Signature.....

.....

Print Name Legibly

Print Name Legibly

SURETY:

Signature

.....

Print Name Legibly

Print Name Legibly

SURETY ADDRESS:

NAME OF LOCAL AGENCY:

.....
.....
.....

ADDRESS
.....
.....

TELEPHONE.....

.....

BOND # _____

CONTRACT PAYMENT BOND
(Surety Company Form)

KNOW ALL MEN BY THESE PRESENTS: That _____
_____ **in the State of** _____, as principal,
and.....

a corporation duly organized under the laws of the State of and having a
usual place of business in
as Surety, are held and firmly bound unto the Treasurer of the State of Maine for the use
and benefit of claimants as herein below defined, in the sum of
_____ **and 00/100 Dollars (\$** _____ **)**
for the payment whereof Principal and Surety bind themselves, their heirs, executors and
administrators, successors and assigns, jointly and severally by these presents.

The condition of this obligation is such that if the Principal designated as Contractor in
the Contract to construct Project Number _____ in the Municipality of
_____ promptly satisfies all claims and demands incurred for all
labor and material, used or required by him in connection with the work contemplated by
said Contract, and fully reimburses the obligee for all outlay and expense which the
obligee may incur in making good any default of said Principal, then this obligation shall
be null and void; otherwise it shall remain in full force and effect.

A claimant is defined as one having a direct contract with the Principal or with a
Subcontractor of the Principal for labor, material or both, used or reasonably required for
use in the performance of the contract.

Signed and sealed this day of, 20

WITNESS:

SIGNATURES:

CONTRACTOR:

Signature.....

.....

Print Name Legibly

Print Name Legibly

SURETY:

Signature.....

.....

Print Name Legibly

Print Name Legibly

SURETY ADDRESS:

NAME OF LOCAL AGENCY:

.....

ADDRESS

.....

.....

TELEPHONE

.....

LABORER: Wheelman.....	\$ 15.64	4.29
OPERATOR:		
Backhoe/Excavator/Trackhoe.....	\$ 19.52	5.15
OPERATOR: Bobcat/Skid		
Steer/Skid Loader.....	\$ 21.98	4.85
OPERATOR: Broom/Sweeper.....	\$ 19.09	5.20
OPERATOR: Bulldozer.....	\$ 17.30	3.50
OPERATOR: Loader.....	\$ 18.59	5.53
OPERATOR: Mechanic.....	\$ 21.91	8.55
OPERATOR: Screed.....	\$ 19.43	4.90
OPERATOR: Roller (Earth).....	\$ 16.43	3.40
TRAFFIC CONTROL: Flagger.....	\$ 9.38	0.00
TRAFFIC CONTROL:		
Laborer-Cones/ Barricades/Barrels - Setter/Mover/Sweeper.....		
	\$ 17.47	4.80
TRUCK DRIVER: Dump Truck.....	\$ 14.32	5.81
TRUCK DRIVER: TackTruck.....	\$ 20.18	7.75

WELDERS - Receive rate prescribed for craft performing operation to which welding is incidental.

=====

Note: Executive Order (EO) 13706, Establishing Paid Sick Leave for Federal Contractors applies to all contracts subject to the Davis-Bacon Act for which the contract is awarded (and any solicitation was issued) on or after January 1, 2017. If this contract is covered by the EO, the contractor must provide employees with 1 hour of paid sick leave for every 30 hours they work, up to 56 hours of paid sick leave each year. Employees must be permitted to use paid sick leave for their own illness, injury or other health-related needs, including preventive care; to assist a family member (or person who is like family to the employee) who is ill, injured, or has other health-related needs, including preventive care; or for reasons resulting from, or to assist a family member (or person who is like family to the employee) who is a victim of, domestic violence, sexual assault, or stalking. Additional information on contractor requirements and worker protections under the EO is available at <https://www.dol.gov/agencies/whd/government-contracts>.

Note: Executive Order 13658 generally applies to contracts subject to the Davis-Bacon Act that were awarded on or between January 1, 2015 and January 29, 2022, and that have not been renewed or extended on or after January 30, 2022. Executive Order 13658 does not apply to contracts subject only to the Davis-Bacon Related Acts regardless of when they were awarded. If a contract is subject to Executive Order 13658, the contractor must pay all covered workers at least \$13.30 per hour (or the applicable wage rate listed on this wage determination, if it is higher) for all hours spent performing on the contract in 2025. The applicable Executive Order minimum wage rate will be adjusted annually. Additional information on contractor requirements and worker protections under Executive Order 13658 is available at

www.dol.gov/whd/govcontracts.

Unlisted classifications needed for work not included within the scope of the classifications listed may be added after award only as provided in the labor standards contract clauses (29CFR 5.5 (a) (1) (iii)).

The body of each wage determination lists the classifications and wage rates that have been found to be prevailing for the type(s) of construction and geographic area covered by the wage determination. The classifications are listed in alphabetical order under rate identifiers indicating whether the particular rate is a union rate (current union negotiated rate), a survey rate, a weighted union average rate, a state adopted rate, or a supplemental classification rate.

Union Rate Identifiers

A four-letter identifier beginning with characters other than ""SU"", ""UAVG"", ?SA?, or ?SC? denotes that a union rate was prevailing for that classification in the survey. Example: PLUM0198-005 07/01/2024. PLUM is an identifier of the union whose collectively bargained rate prevailed in the survey for this classification, which in this example would be Plumbers. 0198 indicates the local union number or district council number where applicable, i.e., Plumbers Local 0198. The next number, 005 in the example, is an internal number used in processing the wage determination. The date, 07/01/2024 in the example, is the effective date of the most current negotiated rate.

Union prevailing wage rates are updated to reflect all changes over time that are reported to WHD in the rates in the collective bargaining agreement (CBA) governing the classification.

Union Average Rate Identifiers

The UAVG identifier indicates that no single rate prevailed for those classifications, but that 100% of the data reported for the classifications reflected union rates. EXAMPLE: UAVG-OH-0010 01/01/2024. UAVG indicates that the rate is a weighted union average rate. OH indicates the State of Ohio. The next number, 0010 in the example, is an internal number used in producing the wage determination. The date, 01/01/2024 in the example, indicates the date the wage determination was updated to reflect the most current union average rate.

A UAVG rate will be updated once a year, usually in January, to reflect a weighted average of the current rates in the collective bargaining agreements on which the rate is based.

Survey Rate Identifiers

The ""SU"" identifier indicates that either a single non-union rate prevailed (as defined in 29 CFR 1.2) for this classification in the survey or that the rate was derived by computing a weighted average rate based on all the rates reported in the survey for that classification. As a weighted average rate includes all rates reported in the survey, it may include both union and non-union rates. Example: SUFL2022-007 6/27/2024. SU indicates the rate is a single non-union prevailing rate or a weighted average of survey data for that classification. FL indicates the State of Florida. 2022 is the year of the survey on which these classifications and rates are based.

The next number, 007 in the example, is an internal number used in producing the wage determination. The date, 6/27/2024 in the example, indicates the survey completion date for the classifications and rates under that identifier.

?SU? wage rates typically remain in effect until a new survey is conducted. However, the Wage and Hour Division (WHD) has the discretion to update such rates under 29 CFR 1.6(c)(1).

State Adopted Rate Identifiers

The ""SA"" identifier indicates that the classifications and prevailing wage rates set by a state (or local) government were adopted under 29 C.F.R 1.3(g)-(h). Example: SAME2023-007 01/03/2024. SA reflects that the rates are state adopted. ME refers to the State of Maine. 2023 is the year during which the state completed the survey on which the listed classifications and rates are based. The next number, 007 in the example, is an internal number used in producing the wage determination. The date, 01/03/2024 in the example, reflects the date on which the classifications and rates under the ?SA? identifier took effect under state law in the state from which the rates were adopted.

WAGE DETERMINATION APPEALS PROCESS

- 1) Has there been an initial decision in the matter? This can be:
 - a) a survey underlying a wage determination
 - b) an existing published wage determination
 - c) an initial WHD letter setting forth a position on a wage determination matter
 - d) an initial conformance (additional classification and rate) determination

On survey related matters, initial contact, including requests for summaries of surveys, should be directed to the WHD Branch of Wage Surveys. Requests can be submitted via email to davisbaconinfo@dol.gov or by mail to:

Branch of Wage Surveys
Wage and Hour Division
U.S. Department of Labor
200 Constitution Avenue, N.W.
Washington, DC 20210

Regarding any other wage determination matter such as conformance decisions, requests for initial decisions should be directed to the WHD Branch of Construction Wage Determinations. Requests can be submitted via email to BCWD-Office@dol.gov or by mail to:

Branch of Construction Wage Determinations
Wage and Hour Division
U.S. Department of Labor
200 Constitution Avenue, N.W.
Washington, DC 20210

2) If an initial decision has been issued, then any interested party (those affected by the action) that disagrees with the decision can request review and reconsideration from the Wage and Hour Administrator (See 29 CFR Part 1.8 and 29 CFR Part 7) Requests for review and reconsideration can be submitted via email to dba.reconsideration@dol.gov or by mail to:

Wage and Hour Administrator
U.S. Department of Labor
200 Constitution Avenue, N.W.
Washington, DC 20210

The request should be accompanied by a full statement of the interested party's position and any information (wage payment data, project description, area practice material, etc.) that the requestor considers relevant to the issue.

3) If the decision of the Administrator is not favorable, an interested party may appeal directly to the Administrative Review Board (formerly the Wage Appeals Board). Write to:

Administrative Review Board
U.S. Department of Labor
200 Constitution Avenue, N.W.
Washington, DC 20210.

=====

END OF GENERAL DECISION

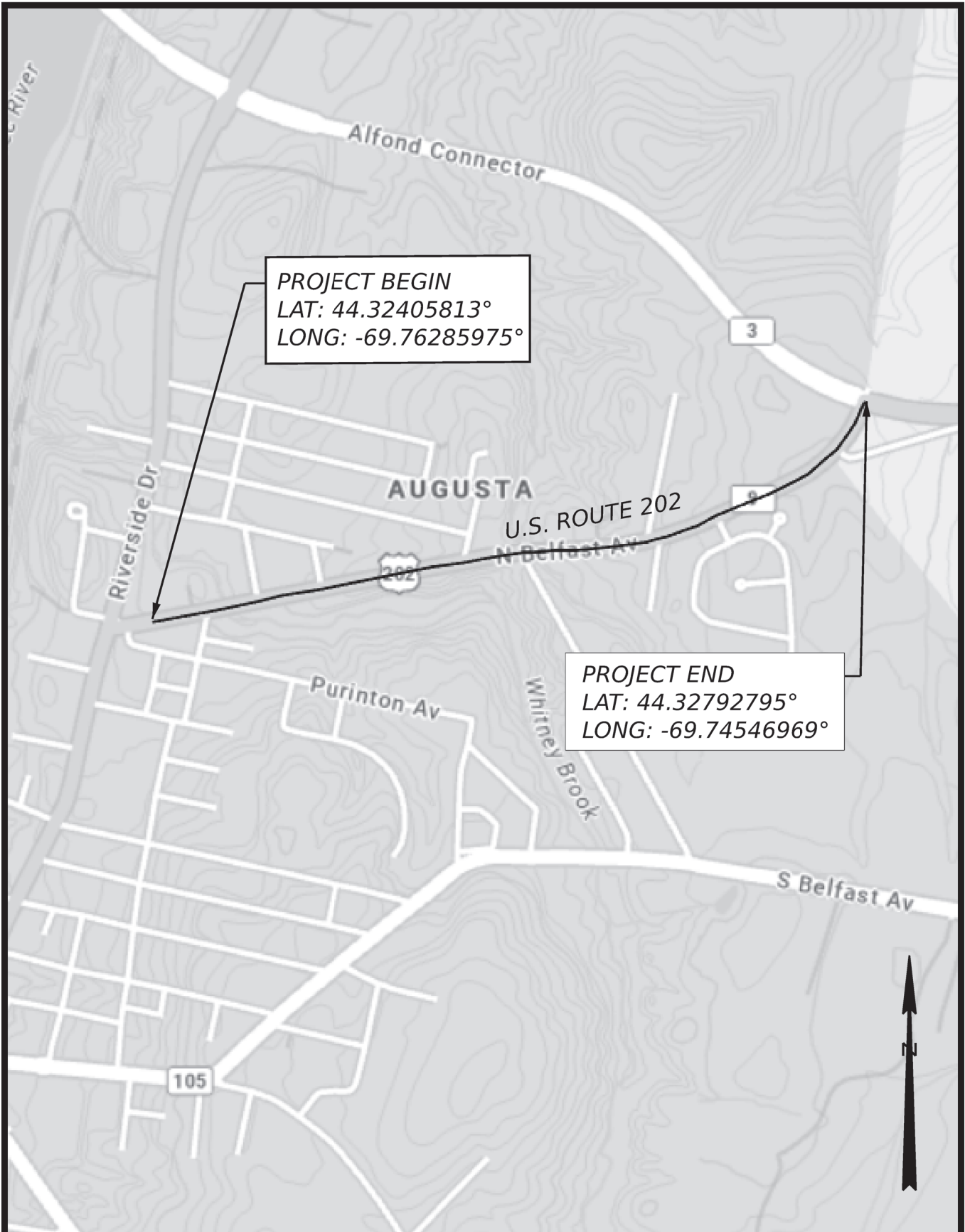

STATE OF MAINE DEPARTMENT OF TRANSPORTATION	U.S. ROUTE 202 AUGUSTA KENNEBEC COUNTY	SHEET NUMBER 1
28356.00	LOCATION MAP	OF 1

STATE OF MAINE
DEPARTMENT OF TRANSPORTATION



AUGUSTA
KENNEBEC COUNTY
U.S. ROUTE 202
FEDERAL PROJECT NO. 2835600
PROJECT LENGTH: 0.94 MILES

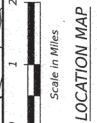
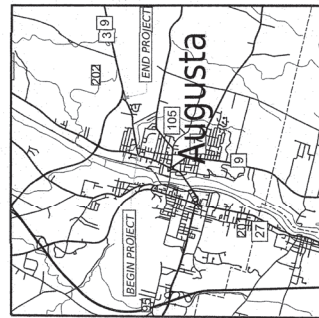

PROJECT LOCATION:	BEGINNING 0.06 MILES EAST OF ROUTE 201 AND EXTENDING EAST 0.94 MILES TO ROUTE 3.
PROGRAM AREA:	REGIONAL PROGRAM
SCOPE OF WORK:	MILL AND FILL

Current (2027) AADT	5030
Future (2047) AADT	5530
DHV - % of AADT	11%
Design Hour Volume	608
% Heavy Trucks (AADT)	2%
% Heavy Trucks (DHV)	2%
Directional Distribution (DHV)	62%
18-kip Equivalent P-2.0	38
18-kip Equivalent P-2.5	37
Design Speed (mph)	30
Corridor Priority	2

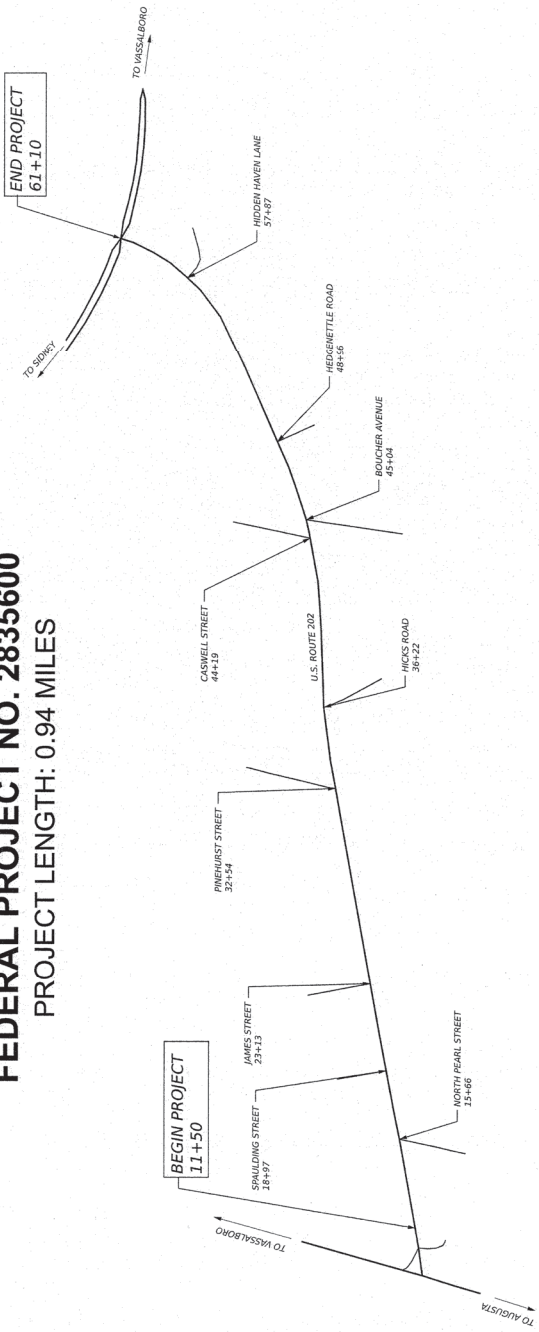

PROJECT INFORMATION PROJECT NUMBER: 2835600 PROJECT RESIDENT: [Blank] CONSULTANT: [Blank] DESIGNER: [Blank] PROJECT MANAGER: [Blank] REGIONAL PROGRAM: [Blank]	PROJECT INFORMATION PROJECT NUMBER: 2835600 PROJECT RESIDENT: [Blank] CONSULTANT: [Blank] DESIGNER: [Blank] PROJECT MANAGER: [Blank] REGIONAL PROGRAM: [Blank]	TITLE SHEET U.S. ROUTE 202 AUGUSTA	SHEET NUMBER 1 OF 1
STATE OF MAINE PROFESSIONAL ENGINEER 13222 Robert K. Betz	DATE: 3/20/2026 P.E. NUMBER: 13222 SIGNATURE: [Signature]	APPROVED DATE: 4/13/2026 CHIEF ENGINEER: [Signature]	STATE OF MAINE DEPARTMENT OF TRANSPORTATION

FEDERAL PROJECT NO. 2835600

2" MILL AND FILL WITH CURB

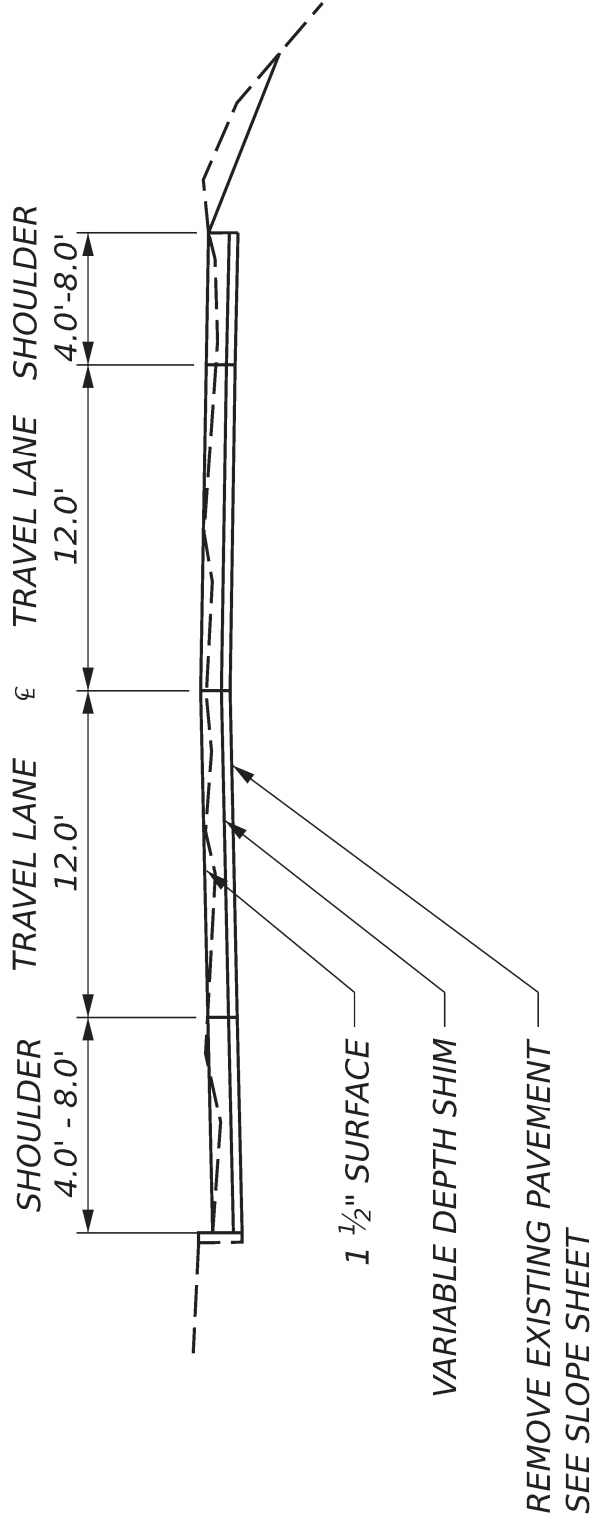

AUGUSTA
U.S. ROUTE 202

TYPICAL SECTIONS

WIN 28356.00

STATE OF MAINE
DEPARTMENT OF TRANSPORTATION

2835600 HIGHWAY PLANS

NOT TO SCALE
SHEET NUMBER
1 OF 4

2" MILL AND FILL WITH CURB AND TURN LANE

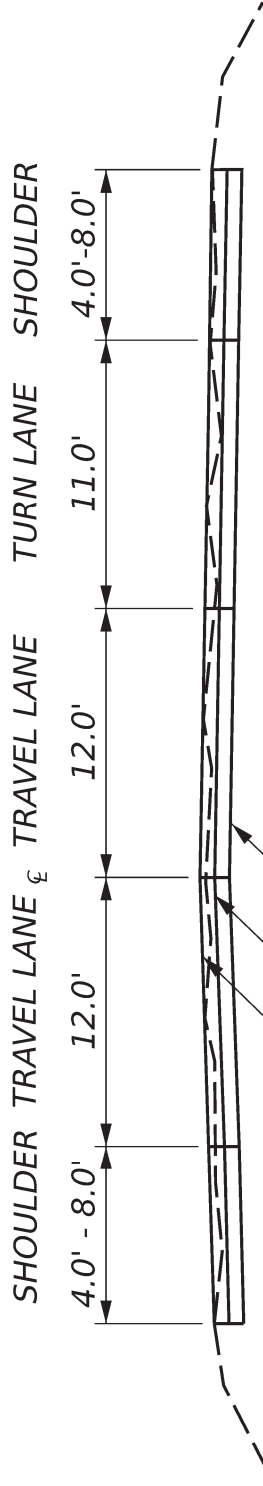

1 1/2" SURFACE

VARIABLE DEPTH SHIM

REMOVE EXISTING PAVEMENT
SEE SLOPE SHEET

STATION
59+50 - 61+00

AUGUSTA U.S. ROUTE 202 TYPICAL SECTIONS	STATE OF MAINE DEPARTMENT OF TRANSPORTATION 2835600	WIN 28356.00
		HIGHWAY PLANS
NOT TO SCALE		SHEET NUMBER 2 OF 4

2" MILL AND FILL WITH BASE REPAIR

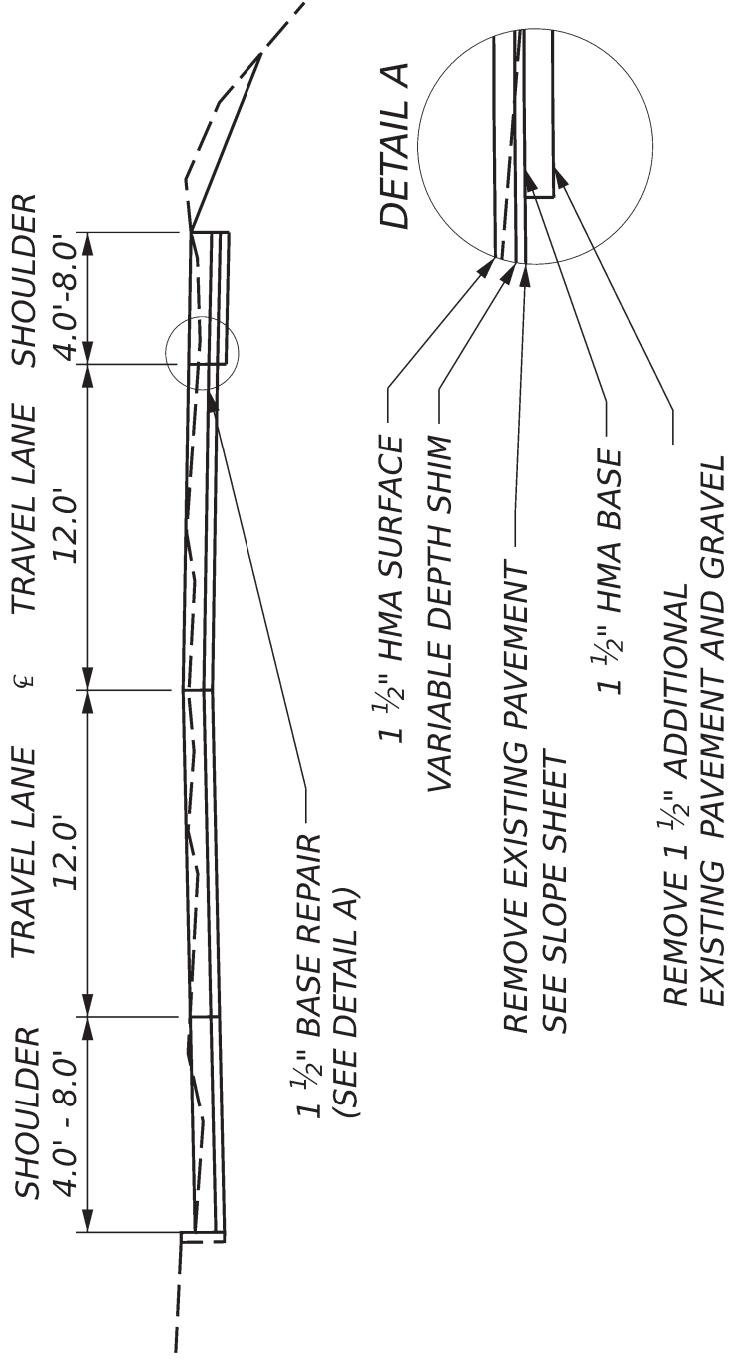

STATION

51+00 - 59+50

AUGUSTA U.S. ROUTE 202 TYPICAL SECTIONS	STATE OF MAINE DEPARTMENT OF TRANSPORTATION 2835600 WIN 28356.00 HIGHWAY PLANS	NOT TO SCALE SHEET NUMBER 3 OF 4
---	--	--

WINTER SAND REMOVAL
NORMAL TYPICAL

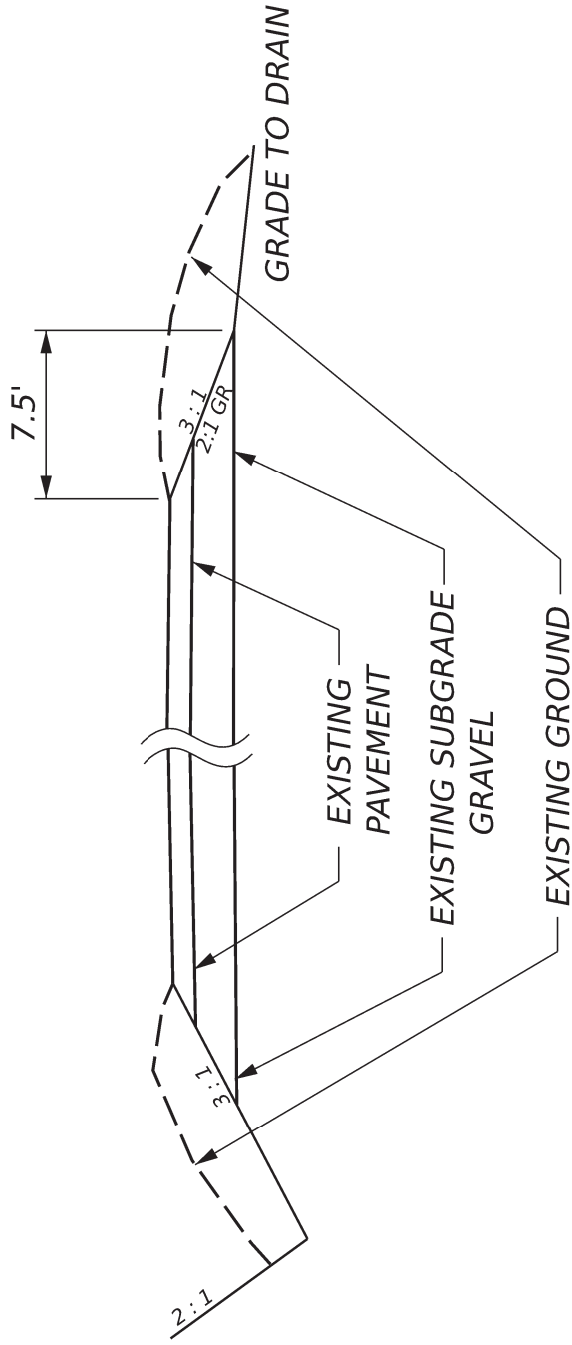

AUGUSTA		STATE OF MAINE		NOT TO SCALE
U.S. ROUTE 202		DEPARTMENT OF TRANSPORTATION		SHEET NUMBER
TYPICAL SECTION		WIN 28356.00	2835600	4 OF 4
		HIGHWAY PLANS		

PROJECT STATIONING

Project Ends	61+10	Project Ends
	57+87	Hidden Haven Lane
	48+96	Hedgenettle Road
	45+04	Boucher Road
Caswell Street	44+19	
	36+22	Hicks Road
Pinehurst Street	32+54	
James Street	23+13	
Spaulding Street	18+97	
	15+66	North Pearl Street
Project Begins	11+50	Project Begins

CONSTRUCTION NOTES

202.202 Removing Pavement Surface

Station 11+50 to Station 61+10 full width.

Station 51+00 to Station 59+50 RT shoulder requires double mill to be based in as milling occurs.

Millings/grindings will become property of the Department. Millings/grindings shall be delivered and stockpiled at the Belgrade Maintenance Camp in Belgrade located at 95 Cemetery Road, Belgrade ME 04917. Payment for delivery and stockpiling will be incidental to Item 202.202. Stockpiling shall include all equipment, personnel, and normal construction practices must be followed constructing stockpiles.

Reference Cross Slope Sheet for centerline and edge of pavement markups/markdowns.

Side roads will be laid out in the field for limits of work.

202.203 Pavement Butt Joints

Shall be used to install pavement butt joints at paved driveways and other locations determined by the Department.

203.20 Common Excavation

Shall be used to remove material where ADA ramps are to be installed.

Shoulder Excavation areas

LT	RT
36+00 to 37+00	
51+50 to 60+00	

304.10 Aggregate Subbase Course Gravel

Shall be used in areas of Regrade sidewalks (Item 608.46) with inadequate gravel base for pedestrian ramps/sidewalks as directed by the resident.

403.209 Hot Mix Asphalt, 9.5 mm (Sidewalks, Drives, Islands & Incidentals)

Shall be used to match into paved driveways and pave sidewalks in where ADA Ramps are being installed, and at other locations as determined by the Department. Side roads will be laid out by the Department to define pavement limits after completion of milling.

CONSTRUCTION NOTES

403.2111 Hot Mix Asphalt, 9.5 mm Nominal Maximum Size Shim (Polymer Modified)

Variable depth shim on milled surfaces and any other locations to be determined in the field by the Department.

403.2131 Hot Mix Asphalt 12.5mm Base

Shall be used to base in the shoulder double mill area from station 51+00 to 59+50 RT (shoulder), for structures being adjusted and at other locations as determined by the Department.

424.22 Asphalt Rubber Crack Sealer, Type 2, Applied

Shall be used on all longitudinal/transverse cracks ½” – 1 ½” width as directed by the Department on mainline/shoulders after milling operations are completed. Cracks shall be flush filled with appropriate nozzle attachments. Excessive over banding will not be permitted.

424.38 Hot Pour Mastic Crack Sealer, Applied

Shall be used on all longitudinal/transverse cracks greater than 1 ½” in width as directed by the department on mainline/shoulders after milling operations are completed. Cracks shall be flush filled with appropriate nozzle attachment. Excessive over banding will not be permitted.

604.161 Alter Catch Basin

LT	RT
17+02	

604.18 Adjust Catch Basin or Manhole to Grade

LT	RT
12+12	12+12
14+44	13+18
20+35	20+19
26+49	26+54
36+43	

CONSTRUCTION NOTES

608.26 Curb Ramp Detectable Warning Field

LT
15+60- 2'x4'
18+80- 2'x4'
19+15 - 2'x4'
32+25- 2'x4'
32+80- 2'x4'
35+40- 2'x4'

RT
North Pearl Street- 2'x5'
Hicks Road- Approximately 2'x5'

608.46 Regrading Sidewalk

LT
15+60- Approximately 8'
18+80- Approximately 8'
19+15- Approximately 8'
32+25- Approximately 10'
32+80- Approximately 10'
35+40- Approximately 8'

RT
North Pearl Street- Approximately 15'
Hicks Road- Approximately 15'

609.31 Curb Type 3

Station 40+45 to 40+90 LT and undetermined locations are likely to be added as milling occurs, as well as ADA ramp installation areas.

LT
15+60- Approximately 8'
18+80- Approximately 8'
19+15- Approximately 8'
32+25- Approximately 10'
32+80- Approximately 10'
35+40- Approximately 8'

RT
North Pearl Street- Approximately 15'

Existing curb to be removed and paid under equipment rental items.

627.733 4" White or Yellow Painted Pavement Marking Line

Center lines and edge lines shall be painted on all matched pavement within one week. Center line TOMs may be utilized until final striping and will be considered incidental to the contract.

Multilane sections and truck lanes must be striped daily on all matched pavement layers.

Prior to final marking line application on surface course the Contractor will confirm and receive approval for marking line layout from the Department

CONSTRUCTION NOTES

627.75 - White or Yellow Pavement & Curb Marking

One application of paint will be required on the surface course.

The Contractor will replace all existing stencils. Prior to final stencil application on the surface course, the contractor shall confirm and receive approval for marking line layout from the Department.

627.78 Temporary 4" Painted Pavement Marking Line, White or Yellow

Temporary center lines and edge lines shall be painted on all matched pavement within one week.

Multilane sections, truck lanes, and milled surfaces must be striped daily on all matched pavement layers.

Temporary lines will require one coat on the milled surface.

629.05, 631.12, 631.172 - Hand Labor, A.P.E., Truck – Large

Rental items to be used for removal of winter sand, backing up pavement, removal of existing curb to be replaced or as directed by the Department.

652.35 Construction Signs

Road Work Ahead and **End Road Work** signs are required for the beginning and end of the project.

The following side roads will require **Road Work 500 Feet** and **End Road Work** signs:

- N. Pearl Street
- Spaulding Street
- Pinehurst Street
- Hicks Road
- Hedgenettle Road
- Route 3 North
- Route 3 South

CROSS SLOPE SHEET

STA	LEFT		CL Cut/ Fill (inch)	RIGHT		STA	LEFT		CL Cut/ Fill (inch)	RIGHT	
	Shldr EOP Cut/ Fill (inch)	Travel Lane Slope %		Travel Lane Slope %	Shldr EOP Cut/ Fill (inch)		Shldr EOP Cut/ Fill (inch)	Travel Lane Slope %		Travel Lane Slope %	Shldr EOP Cut/ Fill (inch)
37+00					1.00						
36+50	0.50	-2.5			-2.00						
36+00	-2.00	-2.0	1.00		-2.00						
35+50			0.75		1.00	61+10	-2.00	Match	-2.00	Match	-2.00
35+00			1.00			60+50	-2.00	-2.0		-2.0	
						60+00			-2.00		-2.00
33+50			1.00		1.00	59+50			-1.00	-2.0	-1.50
33+00			0.50		3.25	59+00				-2.5	
32+50					4.50						
32+00			0.50		2.25	55+00			-1.00		
31+50			0.00		-2.00	54+50			-2.00		
31+00			-0.50								
30+50			-1.00			53+50					-1.50
30+00			-2.00		-2.00	53+00					-1.00
29+50					-2.25						
						52+00					-1.00
28+50					-2.25	51+50					0.50
28+00					-2.75	51+00					-0.75
27+50					-2.00	50+50					-0.25
						50+00				-2.5	-1.50
26+00					-2.00	49+50				-2.0	-2.00
25+50			-2.00		-2.00	49+00				-1.0	
25+00	-2.00		-1.25		-2.75	48+50	-2.00			-1.0	
24+50	-1.25		-1.25		-2.25	48+00	-1.75	-2.0		1.0	
24+00	-2.00		-0.75		-2.25	47+50	-2.00	-2.5		2.0	
23+50			-1.25		-2.00						
23+00			-2.00			46+00	-2.00			2.0	
						45+50	-1.75			2.5	
19+50		-2.0				45+00	-2.00				
19+00		-2.5									
						44+00				2.5	
15+50		-2.5				43+50				2.0	
15+00		-3.0									
14+50			-2.00			42+00			-2.00		
14+00			-1.25		-2.00	41+50	-2.00		-1.25	2.0	
13+50			-0.75		-1.50	41+00	0.75		-0.50	1.5	
13+00			-1.25		-1.50	40+50	1.00		0.00	1.0	-2.00
12+50	-2.00		-2.00		0.00	40+00	1.25		0.50	0.5	0.50
12+00	0.50	-3.0	-2.00		-2.00	39+50	0.50		1.00	-0.5	0.50
11+50	0.50	-2.0	-1.75			39+00				-1.0	1.00
11+00	-2.00	Match	-2.00	Match	-2.00	38+50				-2.0	

- Notes:
1. For areas with a positive () cut depth, the mill will cut 0" at control line and profile mill through the section. Shimming will be 0.5" loose at the centerline for milled areas.
 2. Positive () Cut Depths are considered shim and will be the "loose" uncompacted depth at the control line.

GENERAL NOTES

1. Pavement thicknesses shown on the typical sections are intended to be nominal.
2. All joints between existing and proposed hot bituminous pavement shall be butted. Payment shall be made under Standard Specifications Item 202.203, Pavement Butt Joints.
3. Construct butt joints at all paved drives and entrances. Butt joints shall have a minimum width of 18 inches or as directed by the Resident.
4. The Contractor shall place suitable existing or other material acceptable to the Resident on all pavement edges to allow a drop off no greater than the surface pavement thickness. The material shall be graded to match the existing inslope or as directed by the Resident before surface is placed. The Contractor will be paid under appropriate equipment rental items. Borrow is not authorized until all acceptable waste material has been utilized. Seed and Mulch will be paid for at the contract unit price.
5. All waste material not used on the project shall be disposed of off the project in acceptable waste areas reviewed by the Resident. Grading, seeding and mulching of waste areas shall be considered incidental.
6. A 3-foot paved lip shall be placed at all unpaved entrances unless otherwise noted in the Plans or directed by the Resident.
7. Any necessary cleaning of existing pavement prior to paving (or milling) shall be incidental to the related paving (or milling) items. This includes killing and removal of all vegetative matter.
8. All existing paved shoulders and widenings shall be resurfaced as directed by the Resident.
9. When superelevation exceeds the slope of the low-side shoulder, the low-side shoulder will have same slope as the travelway.
10. Cross slopes for normal and superelevated sections will be straight unless otherwise directed by the Department.
11. The algebraic difference between travelway and shoulder cross slope shall not exceed 8 percent.
12. Backing up bituminous or concrete slipform curb is incidental to the curb items. In areas where new bituminous or concrete slipform curb is designated to replace existing, the removal of the old bituminous or concrete slipform curb shall be incidental to the new curb. If called for on the Plans or directed by the Resident, loam or dirty borrow will be paid for separately.

GENERAL NOTES

13. Loam has been estimated for disturbed lawn areas. Actual placement of the loam shall be as noted on the Plans or designated by the Resident.
14. Loam shall be placed to a nominal depth of 4 inches in lawn areas and 2 inches in all other areas unless otherwise noted or directed.
15. The Contractor will be responsible for maintaining all existing mailboxes to ensure that the mail will be deliverable. Payment for this work will be considered incidental to the contract.
16. The Contractor will be responsible for maintaining all existing operational business directional signs (OBDS) to ensure that they are visible to the traveling public. Payment for this work will be considered incidental to the contract.
17. Any damage to the slopes caused by the Contractor's equipment, personnel, or operation shall be repaired to the satisfaction of the Resident. All work, equipment, and materials required to make repairs shall be at the Contractor's expense.
18. No separate payment for superintendent or foreman will be made for the supervision of equipment and layout of work being paid for under the equipment rental items.
19. "Undetermined locations" shall be determined by the Resident.
20. Stations referenced are approximate.
21. Final striping for the project shall be done by the Contractor per the striping layout in the Contract documents or as provided by the Department. Payment shall be made under appropriate Contract items.
22. The Contractor will place appropriately-marked stakes at the following locations on the project: striping pattern changes, cross-slope changes, and every 500 feet for stationing. The Contractor will paint every full station (100 feet) on the existing roadway and will transfer the painted stationing through all intermediate lifts (not surface). Appropriately-sized striping pattern changes will be painted on surface. Stationing control must be placed before work can commence. Cross-slope and striping change controls must be placed before paving can commence.
23. All HMA for patching around adjusted, altered, or rebuilt utility structures shall be a 9.5 mm or 12.5 mm MaineDOT approved mix design. Excluding water and gas gate valves, the Contractor shall saw cut the existing pavement for the patch at least two feet away from the nearest edge of the structure. The Contractor shall place HMA in lifts of 2 inches or less to match the existing pavement depth or a maximum of 6 inches, as directed by the Resident, and compact the HMA using a minimum of a 150-pound plate compactor. HMA for patching around adjusted, altered, or rebuilt utility structures is considered incidental to the respective pay item for adjust, alter, or rebuild utility structure.

GENERAL NOTES

1. Pavement thicknesses shown on the typical sections are intended to be nominal.
2. All joints between existing and proposed hot bituminous pavement shall be butted. Payment shall be made under Standard Specifications Item 202.203, Pavement Butt Joints.
3. Construct butt joints at all paved drives and entrances. Butt joints shall have a minimum width of 18 inches or as directed by the Resident.
4. The Contractor shall place suitable existing or other material acceptable to the Resident on all pavement edges to allow a drop off no greater than the surface pavement thickness. The material shall be graded to match the existing inslope or as directed by the Resident before surface is placed. The Contractor will be paid under appropriate equipment rental items. Borrow is not authorized until all acceptable waste material has been utilized. Seed and Mulch will be paid for at the contract unit price.
5. All waste material not used on the project shall be disposed of off the project in acceptable waste areas reviewed by the Resident. Grading, seeding and mulching of waste areas shall be considered incidental.
6. A 3-foot paved lip shall be placed at all unpaved entrances unless otherwise noted in the Plans or directed by the Resident.
7. Any necessary cleaning of existing pavement prior to paving (or milling) shall be incidental to the related paving (or milling) items. This includes killing and removal of all vegetative matter.
8. All existing paved shoulders and widenings shall be resurfaced as directed by the Resident.
9. When superelevation exceeds the slope of the low-side shoulder, the low-side shoulder will have same slope as the travelway.
10. Cross slopes for normal and superelevated sections will be straight unless otherwise directed by the Department.
11. The algebraic difference between travelway and shoulder cross slope shall not exceed 8 percent.
12. Backing up bituminous or concrete slipform curb is incidental to the curb items. In areas where new bituminous or concrete slipform curb is designated to replace existing, the removal of the old bituminous or concrete slipform curb shall be incidental to the new curb. If called for on the Plans or directed by the Resident, loam or dirty borrow will be paid for separately.
13. Loam has been estimated for disturbed lawn areas. Actual placement of the loam shall be as noted on the Plans or designated by the Resident.

GENERAL NOTES

14. Unless otherwise noted Seeding Method No. 1 shall be utilized on all lawns and developed areas; Seeding Method No. 2 shall be utilized on all other areas.
15. Loam shall be placed to a nominal depth of 4 inches in lawn areas and 2 inches in all other areas unless otherwise noted or directed.
16. The Contractor will be responsible for maintaining all existing mailboxes to ensure that the mail will be deliverable. Payment for this work will be considered incidental to the contract
17. The Contractor will be responsible for maintaining all existing operational business directional signs (OBDS) to ensure that they are visible to the traveling public. Payment for this work will be considered incidental to the contract.
18. Any damage to the slopes caused by the Contractor's equipment, personnel, or operation shall be repaired to the satisfaction of the Resident. All work, equipment, and materials required to make repairs shall be at the Contractor's expense.
19. No separate payment for superintendent or foreman will be made for the supervision of equipment and layout of work being paid for under the equipment rental items.
20. "Undetermined locations" shall be determined by the Resident.
21. Stations referenced are approximate.
22. Final striping for the project shall be done by the Contractor per the striping layout in the Contract documents or as provided by the Department. Payment shall be made under appropriate Contract items.
23. The Contractor will place appropriately-marked stakes at the following locations on the project: striping pattern changes, cross-slope changes, and every 500 feet for stationing. The Contractor will paint every full station (100 feet) on the existing roadway and will transfer the painted stationing through all intermediate lifts (not surface). Appropriately-sized striping pattern changes will be painted on surface. Stationing control must be placed before work can commence. Cross-slope and striping change controls must be placed before paving can commence.
24. All HMA for patching around adjusted, altered, or rebuilt utility structures shall be a 9.5 mm or 12.5 mm MaineDOT approved mix design. Excluding water and gas gate valves, the Contractor shall saw cut the existing pavement for the patch at least two feet away from the nearest edge of the structure. The Contractor shall place HMA in lifts of 2 inches or less to match the existing pavement depth or a maximum of 6 inches, as directed by the Resident, and compact the HMA using a minimum of a 150-pound plate compactor. HMA for patching around adjusted, altered, or rebuilt utility structures is considered incidental to the respective pay item for adjust, alter, or rebuild utility structure.

SPECIAL PROVISION
SECTION 104
GENERAL RIGHTS AND RESPONSIBILITIES
(Electronic Payroll Submission)
(Payment Tracking)

104.3.8.1 Electronic Payroll Submission The prime contractor and all subcontractors and lower-tier subcontractors will submit their certified payrolls electronically on this contract utilizing the Elation System web based reporting. There is no charge to the contracting community for the use of this service. The submission of paper payrolls will not be allowed or accepted. Additional information can be found at <http://www.maine.gov/mdot/contractors/> under the first “Notice”.

104.3.8.2 Payment Tracking The prime contractor and all subcontractors and lower-tier subcontractors will track and confirm the delivery and receipt of all payments through the Elation System

**SPECIAL PROVISIONS
 SECTION 104
 UTILITIES**

UTILITY COORDINATION

The Contractor has primary responsibility for coordinating their work with Utilities **AFTER** contract award. The Contractor shall communicate directly with the Utilities regarding any utility work necessary to maintain the Contractor’s schedule and prevent project construction delays. The Contractor shall notify the Resident of any issues.

THE CONTRACTOR SHALL PLAN AND CONDUCT WORK ACCORDINGLY.

MEETING

A Preconstruction Utility Conference, as defined in Subsection 104.4.6 of the Standard Specifications **{IS}**. The Contractor shall conduct work in accordance with MaineDOT Standard Specifications 104.3.11.

GENERAL INFORMATION

These Special Provisions outline the arrangements that have been made by the Department for utility and/or railroad work to be undertaken in conjunction with this project. The following list identifies all known Utilities or Railroads having facilities presently located within the limits of this project or intending to install facilities during project construction.

Utilities have been notified and will be furnished a project specification.

The Contractor shall give all Utilities **ten (10) working days’ notice** prior to beginning **ANY** work on this project. In addition to the 10 working days’ notice, the Contractor shall adhere to any specific notification periods stipulated in the utility/railroad summaries below.

OVERVIEW

Utility	Aerial	Under ground	Contact Person	Contact Phone
Central Maine Power Company	X	X	Josh Shanholtzer	C:207-593-6168
Charter/Spectrum Communications	X		Joshua Mooers	O:207-620-3409 C:207-446-8553
Consolidated Communications Inc./Fidium	X	X	Jim Scheid Eric Nored	O:207-626-2031 C:207-462-9963
Firstlight	X		Jarrold Smith	C:603-396-1100
Gonetspeed	X		Jim Knight	O:207-688-8284 C:207-590-5111
Greater Augusta Utility District		X	Michael Morey Jason Souzer	O:207-622-3701 C:207-485-2134 207-485-4030
Summit Natural Gas		X	Bryan Foster Bryan Haberman	O:207-621-8000 C:207-465-6400 C:207-331-6574

Temporary utility adjustments **ARE** anticipated. If any unexpected utility relocations become necessary, they shall be scheduled in accordance with Section 104 of the Standard Specifications and shall be performed by the appropriate utility company in conjunction with the work by the Contractor. Should the Contractor choose to have any poles temporarily relocated, all work shall be done at the Contractor's request and expense, with no additional cost or schedule impacts to the Department.

Unless otherwise specified, any underground utility facilities shown on the project plans represent approximate locations gathered from available information. The Department cannot certify the level of accuracy of this data. Underground facilities indicated on the topographic sheets (plan views) have been collected from historical records and/or on-site designations provided by the respective Utilities. Underground facilities indicated on the cross-sections have been carried over from the plan view data and may also include further approximations of the elevations (depths) based upon straight-line interpolation from the nearest manholes, gate valves, or test pits.

All adjustments are to be made by the respective Utility/Railroad unless otherwise specified herein.

Fire hydrants shall not be disturbed until all necessary work has been accomplished to ensure proper fire protection.

**** Specific information regarding the line voltage can be requested from Central Maine Power Co. ****

Utility working days are Monday through Friday. Times are estimated on the basis of a single crew for each utility. Any times and dates mentioned are **estimates only** and are dependent upon favorable weather, working conditions, and freedom from emergencies.

AERIAL

Aerial Utility adjustments **ARE** anticipated for the completion of this project and will be scheduled in compliance with Section 104 of the Standard Specifications.

Summary:

Utility	Pole Set	New Wires/Cables	Trans. Wires/Cables	Remove Poles	Estimated Working Days
Central Maine Power Company	4		6	3	16
Charter/Spectrum	N/A		10	N/A	10
Consolidated Communications	N/A		17	N/A	17
Firstlight	N/A		5	N/A	5
Gonetspeed	N/A		13	N/A	13
Total:					61

Aerial Utility Specific Issues:

Central Maine Power (CMP): CMP has approximately **nine (9)** poles that will need to be relocated and aerial lines to be transferred.

Bangor Street segment: CMP requires **13** working days to complete approximately **seven (7)** pole relocations, line transfers and pole removal.

Cony Circle segment: CMP requires **three (3)** working days to complete approximately **two (2)** pole relocations, line transfers and pole removal.

Charter/Spectrum Communications has ariel communication lines within the project limits that will need to be relocated.

Bangor Street segment: Charter requires **seven (7)** working days to complete their work.

Cony Circle segment: Charter requires **three (3)** working days to complete their work.

Consolidated Communications Inc. (CCI): CCI has ariel communication lines within the project limits that will need to be relocated.

Bangor Street segment: CCI requires **12** working days to complete their work.

Cony Circle segment: CCI requires **five (5)** working days to complete their work.

Firstlight: Firstlight has ariel communication lines within the project limits that will need to be relocated.

Bangor Street segment: Firstlight requires **five (5)** working days to complete their work.

Gonetspeed: Gonetspeed has ariel communication lines within the project limits that will need to be relocated.

Bangor Street segment: Gonetspeed requires **three (3)** working days to complete their work.

Cony Circle segment: Gonetspeed requires **ten (10)** working days to complete their work.

Pole List:

Existing Pole #	Existing Station	Left/Right		Existing Offset	Proposed Station	Left/Right		Proposed Offset	Comments
		LT	RT			LT	RT		
6/6	1000+68		X	46.1	1000+66		X	46	Set new pole relocate aerial to a new pole on Noyes St.PL.
7/7	1001+78		X	52.3	Noyes Street PL		X		Remove existing pole. Set a new pole on Noyes St. PL behind building at 79 Cony St.
1/5	5001+80		X	27.1	5001+80		X	31.1	
1/13	5015+38		X	26.7	5015+38		X	30.7	
16/15	5016+71		X	26.1	5016+71		X	57+16	
21/21	5022+23		X	26.2	5022+23		X	28.2	
22/22	5023+37		X	26.6	5023+37		X	28.6	
UNK (23?)	5024+77		X	26.1	5024+73		X	28.1	
27/27	5030+42		X	27	5030+42		X	29	

SUBSURFACE

There **ARE** subsurface utilities within this road project segment, therefore, utility adjustments **ARE** anticipated in order to complete the scope of this project.

Summary:

Utility	Summary of Work	Estimated Working Days
Central Maine Power Company	Install new underground wire	10
Consolidated Communications	Adjusting approximately 4 manholes	5
Greater Augusta Utility District	Lowering and adjusting to grade approximately 28 sewer manholes and 32 water gate valve boxes Relocation of a 16" water main	49
Summit Natural Gas	Adjusting approximately five (5) gas gate valves	3
Total:		67

NOTE: The Contractor will be responsible to make any final grade adjustments to water gates in conjunction with paving operations, unless otherwise specified by the Utility. The cost of any final adjustments to water gates will be considered incidental to paving items.

Special Funding:

Special Funding requirements for Utilities, such as State Revolving Funding (SRF) will be tracked by the corresponding Utility.

Subsurface Utility Specific Issues:

Central Maine Power (CMP): CMP has entered into an agreement with the Department to have the Contractor install a new duct bank in the Cony Circle segment. The plans can be found in SP 890.01. CMP requires **ten (10)** working days to complete their portion of the underground work.

Consolidated Communications Inc. (CCI): Has approximately **four (4)** manholes in the Bangor Street segment only that will need to be adjusted. **One (1)** manhole is in the travel way CCI requires **one (1)** working day to lower prior to milling and **one (1)** working day to rise to grade prior to surface paving. CCI has approximately **three (3)** manholes in the sidewalk that will need to be adjusted prior to surface paving. CCI requires **three (3)** working days to complete their work.

Greater Augusta Utility District (GAUD): GAUD has water gate valves and sewer manholes within the project limits that will need to be adjusted.

Bangor Street segment: GAUD has approximately **21** sewer manholes that will need to be lowered prior to milling and raised to grade after base/shim paving is completed and prior to surface paving. GAUD requires **seven (7)** working days to lower their structures and **11** working days to raise the structures to grade. GAUD has approximately **23** water gate valve boxes that will need to be lowered prior to milling and raised to grade after base/shim paving is completed and prior to surface paving. GAUD requires **five (5)** working days to lower their structures and **six (6)** working days to raise the structures to grade. **The Contractor will be responsible to make final grade adjustments to the water gate valves in conjunction with the paving operations.**

Cony Circle segment: GAUD has approximately **seven (7)** sewer manholes that will need to be lowered prior to milling and raised to grade after base/shim paving is completed and prior to surface paving. GAUD requires **four (4)** working days to lower their structures and **four (4)** working days to raise the structures to grade. GAUD has approximately **nine (9)** water gate valve boxes that will need to be lowered prior to milling and raised to grade after base/shim paving is completed and prior to surface paving. GAUD requires **three (3)** working days to lower their structures and **five (5)** working days to raise the structures to grade. **The Contractor will be responsible to make final grade adjustments to the water gate valves in conjunction with the paving operations.**

GAUD has a 16" water main that will need to be relocated. GAUD requires **five (5)** working days to complete their work.

Summit Natural Gas (SNG): SNG has a natural gas line, and **five (5)** gate valves located within the Bangor Street project limits. These are located within the sidewalk. SNG requires **three (3)** working days to adjust their gate valves.

MAINTAINING UTILITY LOCATION MARKINGS

The Contractor will be responsible for maintaining the buried utility location markings following the initial locating by the appropriate utility or their designated representative.

UTILITY SIGNING

Any utility working within the construction limits of this project shall ensure that the traveling public is adequately protected at all times. All work areas shall be signed, lighted, and traffic flaggers employed as determined by field conditions. All traffic controls shall be in accordance with the latest edition of the Manual on Uniform Traffic Control Devices for Streets and Highways, as issued by the Federal Highway Administration.

**SPECIAL PROVISIONS
SECTION 104
UTILITIES**

UTILITY COORDINATION

The Contractor has primary responsibility for coordinating their work with Utilities **AFTER** contract award. The Contractor shall communicate directly with the Utilities regarding any utility work necessary to maintain the Contractor’s schedule and prevent project construction delays. The Contractor shall notify the Resident of any issues.

THE CONTRACTOR SHALL PLAN AND CONDUCT WORK ACCORDINGLY.

MEETING

A Preconstruction Utility Conference, as defined in Subsection 104.4.6 of the Standard Specifications, **IS** required. The Contractor shall conduct work in accordance with MaineDOT Standard Specifications 104.3.11.

GENERAL INFORMATION

These Special Provisions outline the arrangements that have been made by the Department for utility and/or railroad work to be undertaken in conjunction with this project. The following list identifies all known Utilities or Railroads having facilities presently located within the limits of this project or intending to install facilities during project construction.

Utilities have been notified and will be furnished a project specification.

The Contractor shall give all Utilities **ten (10) working days’ notice** prior to beginning **ANY** work on this project. In addition to the ten (10) working days’ notice, the Contractor shall adhere to any specific notification periods stipulated in the utility/railroad summaries below.

OVERVIEW

Utility	Aerial	Subsurface	Contact Person	Contact Phone
Augusta City of		X	Lesley Jones	207-626-2435
Central Maine Power Company	X		Josh Shanholtzer	207-593-6168
Charter/Spectrum Communications	X		Joshua Mooers	207-6203409
Fidium/Consolidated Communications	X	X	Eric Nored Jim Scheid	207-462-9963 207-626-2031
Firstlight	X		Jarrold Smith	603-396-1100
Gonetspeed	X		Jim Knight	207-688-8284
Greater Augusta Utility District		X	Jason Souzer Michael Morey	207-485-4030 207-622-3701
Summit Natural Gas		X	Bryan Haberman Bryan Foster	207-331-6574 207-621-8000

Temporary utility adjustments **ARE** anticipated. If any unexpected utility relocations become necessary, they shall be scheduled in accordance with Section 104 of the Standard Specifications and shall be performed by the appropriate utility company in conjunction with the work by the Contractor. Should the Contractor choose to have any poles temporarily relocated, all work shall be done at the Contractor's request and expense, with no additional cost or schedule impacts to the Department.

All adjustments are to be made by the respective Utility/Railroad unless otherwise specified herein.

Fire hydrants shall not be disturbed until all necessary work has been accomplished to ensure proper fire protection.

***** Specific information regarding the line voltage can be requested from Central Maine Power Co. *****

Utility working days are Monday through Friday. Times are estimated on the basis of a single crew for each utility. Any times and dates mentioned are **estimates only** and are dependent upon favorable weather, working conditions, and freedom from emergencies.

AERIAL

Aerial utility adjustments are **NOT** anticipated at this time for the project. Though unexpected, if utility relocations become necessary, they will be scheduled in compliance with Section 104 of the Standard Specifications and will be done by the Utilities after the Contractor has finished their work.

SUBSURFACE

Subsurface Utility adjustments **ARE** anticipated at this time for the completion of this project and will be scheduled in compliance with Section 104 of the Standard Specifications. Adjustments to buried facilities such as sewer manholes, water gate valve boxes, and gas gate valve boxes is required. If adjustment of drainage structures is required, the Department will have them adjusted prior to paving operations. When water gates need adjusting, they will be checked, loosened, and adjusted/lowered by the district

NOTE: The Contractor will be responsible to make any final grade adjustments to water gates in conjunction with paving operations, unless otherwise specified by the Utility. The cost of any final adjustments to water gates will be considered incidental to paving items.

Special Funding:

Special Funding requirements for Utilities, such as State Revolving Funding (SRF) will be tracked by the corresponding Utility.

Summary:

Utility	Summary of Work	Estimated Working Days
Greater Augusta Utility District	Lower and raise approximately 28 water gate valve boxes.	16
Greater Augusta Utility District	Lower and raise approximately 23 sewer manholes.	20
Summit Natural Gas	Lower and raise approximately 3 gas gate vale boxes.	2
Total:		38

Utility Specific Issues:

Greater Augusta Utility District (GAUD): GAUD has a water main and sewer main located within the project limits along with water gate valve boxes and sewer manholes that will need to be adjusted.

GAUD has approximately **28** water gate valve boxes that will need to be broken free and lowered prior to milling and raised to surface grade after base/shim has been completed. GAUD requires **seven (7)** working days to lower the water gate valve boxes and **nine (9)** working days to raise the water gate valve boxes to surface grade.

GAUD has approximately **23** sewer manholes that will need to be lowered prior to milling and raised to surface grade after base/shim has been completed. GAUD requires **12** working days to raise the sewer manholes to surface grade.

GAUD requires **ten (10)** working days’ notice prior to needing **any** adjustments.

NOTE: The Contractor will be responsible to make any final grade adjustments to water gate valve boxes in conjunction with paving operations, unless otherwise specified by the Utility. The cost of any final adjustments to water gates will be considered incidental to paving items.

Summit Natural Gas (SNG): SNG has natural gas distribution mains within the project extending from 160 ft east of N Pearl St up to Caswell St along with gas gate valve boxes that will need to be adjusted. SNG has approximately **three (3)** gas gate valve boxes that will need to be broken free and lowered prior to milling and raised to surface grade after base/shim has been completed.

SNG requires **one (1)** working day to lower the gas gate valve boxes and **one (1)** working day to raise the gas gate valves to surface grade.

SNG requires **ten (10)** working days’ notice prior to needing **any** adjustments

NOTE: The Contractor will be responsible to make any final grade adjustments to gas gate valve boxes in conjunction with paving operations, unless otherwise specified by the Utility. The cost of any final adjustments to water gates will be considered incidental to paving items.

MAINTAINING UTILITY LOCATION MARKINGS

The Contractor will be responsible for maintaining the buried utility location markings following the initial locating by the appropriate utility or their designated representative.

UTILITY SIGNING

Any Utility working within the construction limits of this project shall ensure that the traveling public is adequately protected at all times. All work areas shall be signed, lighted, and traffic flaggers employed as determined by field conditions. All traffic controls shall be in accordance with the latest edition of the Manual on Uniform Traffic Control Devices for Streets and Highways, as issued by the Federal Highway Administration.

SPECIAL PROVISION 105
CONSTRUCTION AREA

Construction Areas located in the City of Augusta have been established by the Maine Department of Transportation (MDOT) in accordance with provisions of 29-A § 2382 Maine Revised Statutes Annotated (MRSA).

The sections of highway under construction in Kennebec County:

Project 025751.00 is located in the city of Augusta on Cony Street West, Memorial Drive, Stone Street, and Cony Street East as they approach Cony Circle, as well as Bangor Street from Cony Circle to North Belfast Avenue.

Project 028356.00 is located in the city of Augusta on US Route 202 (North Belfast Avenue).

Per 29-A § 2382 (7) MRSA, the MDOT may “issue permits for stated periods of time for loads and equipment employed on public way construction projects, United States Government projects or construction of private ways, when within construction areas established by the Department of Transportation. The permit:

A. Must be procured from the municipal officers for a construction area within that municipality;

B. May require the contractor to be responsible for damage to ways used in the construction areas and may provide for:

(1) Withholding by the agency contracting the work of final payment under contract; or

(2) The furnishing of a bond by the contractor to guarantee suitable repair or payment of damages.

The suitability of repairs or the amount of damage is to be determined by the Department of Transportation on state-maintained ways and bridges, otherwise by the municipal officers;

C. May be granted by the Department of Transportation or by the state engineer in charge of the construction contract; and

D. For construction areas, carries no fee and does not come within the scope of this section.”

The Municipal Officers for the City of Augusta agreed that an Overlimit Permit will be issued to the Contractor for the purpose of using loads and equipment on municipal ways in excess of the limits as specified in 29-A MRSA, on the municipal ways as described in the “Construction Area.”

As noted above, a bond may be required by the municipality, the exact amount of said bond to be determined prior to use of any municipal way. The MDOT will assist in determining the bond amount if requested by the municipality.

The maximum speed limits for trucks on any city way will be 25 mph (40 km per hour) unless a higher legal limit is specifically agreed upon in writing by the Municipal Officers concerned.

SPECIAL PROVISION
SECTION 105
General Scope of Work
(Environmental Requirements)

- I. To minimize potential effects to endangered bat species the following is required:
 - A. Tree clearing (see Standard Specifications Section 201, and/or Pay Items 201.11, 201.12, and 201.13) is not allowed during the bat active season (April 15 – October 31) this is a time of year clearing restriction.
 1. **Tree clearing is allowed November 1 – April 14 of any year.**
 - B. Tree clearing is limited to the area shown on the plans and those limits should be reviewed and/or clearly marked in the field prior to mobilization.
 - C. If the Contractor witnesses a bat (dead or alive), any activities that may injure any live bats must cease immediately and the Contractor must contact the MaineDOT Environmental (ENV) Office for further coordination.
 1. Dead and/or injured bats will be collected by a MaineDOT biologist for further investigation.
 2. Work in the vicinity of the live/dead bat sighting will not resume until the ENV office or project resident confirms it is acceptable to do so.
- II. To protect migratory birds pursuant to the Migratory Bird Treaty Act of 1918:
 - A. If the Contractor observes an active bird nest within the project limits, any activities that may disturb the nest or injure birds (i.e., nesting adults, chicks, eggs) must cease immediately, and the Contractor shall contact the ENV Office for further coordination.

SPECIAL PROVISION
SECTION 105
General Scope of Work
(Environmental Requirements)

- I. To protect Northern Long Eared Bat (*Myotis septentrionalis*) a federally Endangered species:
 - A. Ensure all operators, employees, and contractors working in areas of Indiana bat, NLEB, or TCB suitable habitat are aware of all Transportation Agency environmental commitments, including all applicable AMMs.
 - B. Direct temporary lighting away from suitable habitat during the active season. The active season is between April 1 and October 31.
- II. Approvals:
 - A. Temporary Soil Erosion and Water Pollution Control Plan.

**SPECIAL PROVISION
SECTION 105
CONTROL OF WORK**

(Cooperation Between Contractors – Periodic Progress Coordination Meeting)

It is hereby brought to the Contractor's attention that the Department has awarded and plans to award other contracts near the limits of this contract, which may be in progress simultaneously.

The Contractor shall attend periodic meetings for the projects in the greater Augusta area. The projects in the Augusta area may include the following project(s):

- Memorial Bridge, WIN 026164.00

Project Manager: Brian Nichols, PE, MaineDOT Bridge Program
(207) 446-6178
brian.nichols@maine.gov

- Route 202, North Belfast Ave, WIN 028356.00

Project Manager: Rob Betz, PE, MaineDOT Midcoast Region
(207) 624-8223
robert.k.betz@maine.gov

- Cony Circle/Bangor Street, WIN 025751.00

Project Manager: Ernest Martin, MaineDOT Highway Program
(207) 624-3381
Ernest.Martin@maine.gov

The periodic meetings will be held in the Augusta area. The intent of these meetings is to ensure the traffic control measures for the different projects are well coordinated and incidents are coordinated between the above-mentioned projects in accordance with incident management plan/emergency plan that is being developed for the projects.

The Contractor shall cooperate with other Contractors as needed and provide project access as necessary and as directed by the Resident.

The Contractor shall coordinate all activities including traffic control with others to ensure safe travel for all road users. This shall be specifically addressed within the Contractors Traffic Control Plan.

SPECIAL PROVISION
SECTION 105
GENERAL SCOPE OF WORK
(LIMITATIONS OF OPERATIONS)

1. Only one paving operation will be allowed at a time, excluding hand placed paving and milling, unless otherwise approved by the Resident.
2. For the project limits associated with the Cony Circle all milled surfaces must be covered with HMA shim within 24 hours of milling.
3. For the project limits associated with Bangor Street and adjacent side streets, all milled surfaces must be covered with HMA shim within 7 days of milling.
4. Absences must be requested at least 72 hours in advance and are subject to Department approval based on existing roadway conditions, paving deadlines, adherence to schedule, traffic restrictions, detours, etc. The Contractor must assure that the roadway surface and signage are maintained for safe passage of the traveling public during any approved absences. The Contract Completion Date will not be modified due to approved absences.
5. Bangor Street shall maintain one 12-foot-wide lane, minimum, in each direction. Single lane closures will be allowed between 8pm and 6am or as per the Resident. Complete closures are allowed between 9pm and 6am for 15 minutes at a time or as per the Resident.
6. All side roads must remain open and accessible during construction activities. Left turn lane storage should be provided in key locations along Bangor Street as directed by the Resident.
7. All work associated with the Cony Circle, approach roadways and up to Station 5004+00 along Bangor Street shall be completed at night between the hours of 8pm and 6am. Full closures of circle approaches will be permitted along with alternating one-way traffic.
8. The Contractor shall plan operations so that the Resident will have sufficient advance notification to provide the necessary inspection and testing. Sufficient notification is considered 48 hours.
9. The Contractor shall provide the Resident with a 48-hour written notice before beginning night work. After receiving this notice, no work is allowed for 48 hours. Once work has been completed, the Contractor shall provide the same notice to return to day work.
10. The Contractor shall not schedule both day work and night work within the same 24-hour period without prior approval by the Resident and 48-hour notice.
11. The City of Augusta will provide signage to notify the public of necessary parking restrictions requested by the Contractor. The Contractor is responsible for notification/posting signage a minimum of 24 hours prior to its effective date/time.

SPECIAL PROVISION
SECTION 105
GENERAL SCOPE OF WORK
(Build America, Buy America)

105.11 Other Federal Requirements this section is replaced with the following:

105.11 Build America, Buy America Requirements

Unless expressly otherwise provided in the Bid Documents, the following provisions are hereby incorporated into the Contract.

This project is subject to the Buy America (23 CFR 635.410) and Build America, Buy America Act (BABA) included in the Infrastructure Investment and Jobs Act (IIJA), Public Law No. 117-58. Further guidance can be found at the FHWA Buy America Construction Program Guide linked here:

<https://www.fhwa.dot.gov/construction/cqit/buyam.cfm>

The Contractor shall certify compliance with Buy America and BABA in the following categories. An article, material or supply should only be classified into one of the following categories and is classified based on its state when it arrives at the project site.

1. **Iron and Steel:** All iron and steel permanently incorporated into the project must be produced in the United States. The only exception to this requirement is the production of pig iron and the processing, pelletizing, and reduction of iron ore, which may occur in another country. This means all manufacturing processes, from the initial melting stage through the application of coatings, must occur in the United States. Any process that modifies the chemical content, the physical size and shape, or the final finish is considered a manufacturing process, including rolling, extruding, machining, bending, grinding, drilling, and coating. “Coating” includes epoxy coating, galvanizing, painting, or any other coating that protects or enhances the value of the material.

Existing De Minimis Use Exemption for Iron and Steel: The requirements of the law and regulations do not prevent a minimal use of foreign steel and iron materials if the total cost of such materials used does not exceed one-tenth of one percent (0.1%) of the total construction contract price or \$2,500.00, whichever is greater.

2. **Manufactured Products:** Articles, materials, or supplies that have been processed into a specific form and shape, or combined with other articles, materials, or supplies to create a product with different properties than the individual articles, materials, or supplies. If a domestic product is taken out of the United States for any process, it becomes a foreign source material.

All Manufactured Products used in the project must be manufactured in the United States (“final assembly requirement”). “Component” means an article, material, or supply, whether manufactured or unmanufactured, incorporated directly into a manufactured product or, where applicable, an iron or steel product. If a manufactured product is

predominantly iron, steel, or a combination of both it must meet the above requirements for iron and steel products. Predominantly iron or steel or a combination of both means the total cost of the iron and steel content exceeds 50 percent of the total cost of all its components.

Precast concrete products classified as Manufactured Products must additionally have predominantly iron or steel components meet the above requirements for iron and steel. Cabinets or other enclosures of intelligent transportation systems (ITS) and other electronic hardware systems classified as Manufactured Products must also comply with the above requirements for iron and steel if the cabinet or enclosure is predominantly iron or steel.

3. **Construction Materials:** Items, articles, materials, or supplies that consist of only one of the items listed below:
 - i. Non-ferrous metals.
 - ii. Plastic and polymer-based products (including polyvinylchloride, composite building materials, and polymers used in fiber optic cables).
 - iii. Glass (including optic glass);
 - iv. Fiber optic cable.
 - v. Optical fiber.
 - vi. Lumber.
 - vii. Engineered wood; and
 - viii. Drywall.

Minor additions of articles, materials, supplies, or binding agents to a Construction Material do not change the categorization of the Construction Material.

All Construction Materials permanently incorporated into the project must be produced in the United States. For the Construction Material to be considered “produced in the United States,” it must meet the following standards:

- i. Non-ferrous metals. All manufacturing processes, from initial smelting or melting through final shaping, coating, and assembly, occurred in the United States.
- ii. Plastic and polymer-based products. All manufacturing processes, from initial combination of constituent plastic or polymer-based inputs, or where applicable, constituent composite materials, until the item is in its final form, occurred in the United States.
- iii. Glass. All manufacturing processes, from initial batching and melting of raw materials through annealing, cooling, and cutting, occurred in the United States.
- iv. Fiber optic cable (including drop cable). All manufacturing processes, from the initial ribboning (if applicable), through buffering, fiber stranding, and jacketing, occurred in the United

States. All manufacturing processes also include the standards for glass and optical fiber, but not for non-ferrous metals, plastic, and polymer-based products, or any others.

- v. Optical fiber. All manufacturing processes, from the initial preform fabrication stage through the completion of the draw, occurred in the United States.
- vi. Lumber. All manufacturing processes, from the initial debarking through treatment and planning, occurred in the United States.
- vii. Drywall. All manufacturing processes, from initial blending of mined or synthetic gypsum plaster and additives through cutting and drying of sandwiched panels, occurred in the United States.
- viii. Engineered wood. All manufacturing processes, from the initial combination of constituent materials until the wood product is in its final form, occurred in the United States.

Construction Materials brought on site and combined with other materials are not considered Manufactured Products. Items that consist of two or more of the listed Construction Materials that have been combined off-site through a manufacturing process, and items that include at least one of the listed materials combined with a material that is not listed through a manufacturing process should be treated as Manufactured Products rather than as Construction Materials.

Specifically Excluded Materials

Section 70917(c) of the Build America Buy America Act specifically excludes certain materials from being classified as either construction materials or manufactured products. These exclusions include cement and cementitious materials, aggregates (such as stone, sand, or gravel), and aggregate binding agents or additives.

Additionally, when these materials are combined as an unsettled mixture without a final form upon arriving at the work site, such as wet concrete or hot mix asphalt, the mixture is not considered a manufactured product. However, if these same materials are combined off-site to create a finished product, such as precast concrete, that finished product is considered a manufactured product.

Public Interest Waiver of BABA Requirements for De Minimis Costs

The US Department of Transportation issued a public interest Waiver of Buy America Requirements for De Minimis Costs. The Waiver for De Minimis Costs exempts Manufactured Products and Construction Materials produced outside the United States for which the total value of the non-compliant products is no more than the lesser of \$1,000,000 or 5% of total applicable costs for the project.

The obligation to track costs throughout the life of the contract is the Contractor's responsibility. The term "total applicable costs" is defined as the total actual final material cost of the compliant and non-compliant iron and steel, Manufactured Products, and Construction Materials.

Certification

For iron and steel materials and for Manufactured Products produced predominantly of iron or steel or a combination of both*, the Contractor shall submit a certification from the producer of steel or iron, or any product containing steel or iron as a component, stating that all steel or iron furnished or incorporated into the furnished product was manufactured in the United States in accordance with the requirements of the Buy America provisions of 23 CFR § 635.410, as amended. Such certification shall also include (1) a statement that the iron or steel product or component was produced entirely within the United States, or (2) a statement that the iron or steel product or component was produced within the United States, except for minimal quantities of foreign steel and iron valued at \$ (actual value). A “Buy America” Certification is required from each manufacturer, fabricator, supplier, subcontractor that engages in “manufacturing” as defined above.

**Predominantly of iron or steel or a combination of both means that the cost of the iron and steel content exceeds 50% of the total cost of all its components. The cost of iron and steel is the cost of the iron or steel mill products, castings, or forgings utilized in the manufacture of the product and a good faith estimate of the cost of the iron or steel components.*

In addition, upon completion of the project, the Contractor shall certify in writing as to the overall compliance with BABA and provide the total project delivered cost of all foreign Manufactured Products and Construction Materials. The Contractor shall also submit individual certifications from all subcontractors and suppliers that furnish applicable Construction Materials and Manufactured Products valued at \$10,000 or more. Such individual certifications shall be submitted upon delivery of the Construction Material or Manufactured Products to the site.

Example certification:

I hereby certify that this project is in compliance with the Build America, Buy America Act (Public Law 117- 58) requirements for this project. All Iron and Steel, Manufactured Products produced predominantly of steel or iron, Manufactured Products and Construction Materials that are permanently incorporated into the work for this project were produced in the United States of America, with the only exceptions as noted below.

As required, we will maintain all records and documents pertinent to the Build America, Buy America Act requirements, at the address given above, for not less than 3 years from the date of Final Acceptance. These files will be available for inspection and verification by the Maine Department of Transportation and/or the Federal Highway Administration.

We further certify that the total value of foreign steel and iron for this project is \$ _____, said value being less than 0.1% of the total construction contract price or \$2,500.00, whichever is greater.

December 12, 2025

We further certify that the total material cost of foreign Manufactured Products and Construction Materials for this project is \$_____, said value being no more than the lesser of \$1,000,000 or 5% of total applicable costs. The term “total applicable costs” is defined as the total actual final material cost of the compliant and non-compliant iron and steel, Manufactured Products, and Construction Materials.

Signed (*Contractor*)
(*President*) (*Contractor Firm*)

MaineDOT DBE Project Attainment Target (PAT)
for this Project is **0%**

The MaineDOT seeks to meet the specified annual Disadvantaged Business Enterprise (DBE) usage goal set out by 49 CFR 26.45 through the efforts of contractors seeking to employ qualified DBE subcontractors. We seek to meet this goal by race neutral means and do not, at this time, use contract specific requirements for each project. We do however, understand the capacity of Maine's DBE community and the unique characteristics a project may have that would differ from the broad annual goal.

Taking this into consideration, the MaineDOT will review each project and develop an anticipated attainment or Project Attainment Target (PAT) based on several factors that are project specific. Those factors include:

- Scope of Work
- DBE availability according to Specification Item
- Geographic location
- DBE capacity

This PAT is developed to assist contractors to better understand the DBE participation that the MaineDOT can reasonably expect for a specific project. The PAT is NOT a mandate but an assessment of the DBE opportunities that this project could meet or exceed. MaineDOT anticipates that each contractor will make the best effort to reach or exceed the PAT for this project.

SPECIAL PROVISION
SECTION 106 - HOT MIX ASPHALT PAVEMENT

The following subsections of the most current version of Specification 100 – General Conditions have been revised and amended by the following:

106.7.3 Early Termination of Lots

In the event a Lot in progress is terminated prematurely before the Department is able to take the number of acceptance samples required by the test method specified in the Contract, the following will apply as applicable unless otherwise detailed in the specifications for the item:

1. For items under statistical acceptance where payfactors are generated
 - a. If three or more samples have been taken, then payfactors will be generated using the available samples results for the lot.
 - b. If the termination was requested by the Contractor and approved by the Department prior to three samples being taken, then each property's payfactor will be set to 0.80.
 - c. If the termination was initiated by the Department prior to three samples being taken, then each property's payfactor will be set to 1.00 for each property.
2. For items not under statistical acceptance
 - a. If initiated by the contractor and no random sample has been reached the entire lot shall be subject to a penalty of 20% of the item's price.
 - b. If initiated by the contractor and only the most recent sample tonnage has not been reached only the tonnage for that subplot will be subject to a penalty of 20% of the items price.

An HMA mix design aim change request from the Contractor with open Lots in progress will constitute a contractor initiated lot termination. For methods A & C, the minimum samples required to generate a pay factor prior to termination will be three. If a minimum of three samples have not been obtained, then each property's payfactor will be set to 0.80. For methods B & D the minimum number of samples (sublots) required prior to an aim change will be the total tonnage of the lot, or a minimum of three, whichever is less. If the minimum number of samples have not been obtained then the pay adjustment for each of the subplot's properties will be set to 0.80.

SPECIAL PROVISION
SECTION 107
TIME
(Contract Time)

1. The Contractor shall be allowed to commence Work provided that the Contract has been awarded, all required plans/submittals have been received and determined to be acceptable by the Department, and a preconstruction meeting has been held.
2. All work schedule changes shall be submitted to the Department for approval a minimum of 48 hours prior to the requested change.
3. Once operations commence, for every weekday not worked the Contractor shall be assessed liquidated damages per section 107.7.7.2 of the Standard Specifications, excluding days lost to inclement weather, holidays, and approved absences as approved by the Resident.
4. The Contractor shall complete all work associated with Bangor Street from Station 5004+00 to Station 5032+00 by December 31, 2026.
5. The Contractor shall not commence work in the area of Cony Circle and all approach roadways (areas south of Station 5004+00) until March 15, 2027, or as approved by the Resident. This work shall be completed in conjunction with the adjacent Memorial Bridge project (WIN 26164.00).
6. The specified Contract Completion Date is **November 13, 2027**. The Contractor shall complete all work on or before this date.
7. The Contractor shall stop all work and have all lanes open and in a safe operating condition to traffic on the following dates:

2026

Friday, May 22, 2026 at 12:00 pm (noontime) until Tuesday, May 27, 2026 at 6:00 am due to Memorial Day.

Friday, July 3, 2026 at 12:00 pm (noontime) until Monday, July 6, 2026 at 6:00 am due to Independence Day.

Friday, September 4, 2026 at 12:00 pm (noontime) until Tuesday, September 8, 2026 at 6:00 am due to Labor Day.

2027

Friday, May 28, 2027 at 12:00 pm (noontime) until Tuesday, June 1, 2027 at 6:00 am due to Memorial Day.

Friday, July 2, 2027 at 12:00 pm (noontime) until Monday, July 5, 2027 at 6:00 am due to Independence Day.

Friday, September 3, 2027 at 12:00 pm (noontime) until Tuesday, September 7, 2027 at 6:00 am due to Labor Day.

SPECIAL PROVISIONS
SECTION 202
REMOVING STRUCTURES AND OBSTRUCTIONS
(Removing Pavement Surface)

The March 2020 Revision of the Standard Specifications, Section 202-Removing Structures and Obstructions, subsection 202.061-Removing Pavement Surface, has been removed and replaced in its entirety by the following:

202.061 - Removing Pavement Surface The equipment for removing the bituminous surface shall be a power operated milling machine or grinder capable of removing bituminous concrete pavement to the required depth, transverse cross slope, and profile grade using an automated grade and slope control system. The controls shall automatically increase or decrease the pavement removal depth as required, and readily maintain desired cross slope, to compensate for surface irregularities in the existing pavement course. The equipment shall be capable of accurately establishing profile grades by referencing from a fixed reference such as a 30 foot minimum contact ski (floating beam), 24 foot non-contact ski (floating beam) with 3 or more sensors; or 3 non-contact sensors directly affixed at the fore, mid, and aft points of the milling machine. Systems designed to incorporate a contact sensor located at the mid-point of the milling machine in lieu of the non-contact sensor will be permitted. Grade control sensors shall all be located on the same side. A single sensor, contact or otherwise, shall not be permitted unless otherwise approved by the Department.

The rotary drum shall be a minimum of 7 feet in width and utilize carbide tip tools at a minimum triple wrap configuration. The difference in height from the top of any ridge to the bottom of the groove adjacent to that ridge shall not exceed $\frac{1}{4}$ inch. The forward speed of the milling machine shall be adjusted to produce a milled surface meeting the groove spacing, groove depth, and surface tolerance requirements of this specification. The tools on the revolving cutting drum must be continually maintained and shall be replaced as warranted to provide a uniform pavement texture. The Department may evaluate the texture of the milled surface for information purposes by performing the Sand Patch test according to ASTM E 965.

The Contractor shall locate and remove all objects in the pavement through the work area that would be detrimental to the milling or grinding machine. Any structures or obstructions left within the travel lane or shoulders shall have tapers installed according to Standard Detail 202(01). The finished milled surface will be inspected before being accepted, and any deviations in the profile exceeding $\frac{1}{2}$ inch under a 16 foot string line or straightedge placed parallel to the centerline will be corrected. Any deviations in the cross-slope that exceed $\frac{3}{8}$ inch under a 10 foot string line or straightedge placed transversely to centerline will be corrected. All corrections will be made with approved methods and materials. Any areas that require corrective measures will be subject to the same acceptance tolerances. Excess material that becomes bonded to the milled surface will be removed to the Resident's satisfaction before the area is accepted.

On roadways with adjoining lanes carrying traffic, the Contractor shall remove the pavement surface in each lane per the conditions in Table 1, unless otherwise noted by the Department in Special Provision, Section 105 – Limitations of Operations.

TABLE 1: MILLING CONDITIONS FOR ADJOINING LANES

Depth (At Centerline)	Milling Conditions
Vertical Longitudinal Joint	
2” and less	The Contractor may remove the pavement on a single travel lane width for each production day and will be required to mill the adjacent section of travel lane before the end of the following calendar day.
Greater than 2”	The Contractor shall remove the pavement over the full width of the traveled way section being paved that day.
12:1 Tapered Centerline Joint	
1 ½” to 2”	The Contractor may remove the pavement on a single travel lane width for each production day and will be required to mill the adjacent section of travel lane before weekend or holiday suspension. A maximum unmatched centerline joint length of 0.5 miles will be permitted over the weekend.
Greater than 2”	The Contractor shall remove the pavement on a single travel lane width for each production day and will be required to mill the adjacent section of travel lane before the end of the following calendar day.

The Contractor will be required to remove the pavement over the full width of the mainline traveled way, regardless of highway type, cut depth, or longitudinal joint type prior to Memorial Day, July 4th, Labor Day, suspensions exceeding three days, or other dates as specified by Special Provision, Section 105 – Limitations of Operations.

The Contractor will also be responsible for installing additional warning signage that clearly defines the centerline elevation differential hazard. Unless otherwise addressed in the contract, the Contractor shall install additional centerline delineation such as a double RPM application, or temporary painted line. The Traffic Control Plan shall be amended to include this option and the additional requirements. All signs and traffic control devices will conform to Section 719.01, and Section 652, and will be installed prior to the work, at a maximum spacing of 0.50 mile for the entire length of effected roadway section. If this option is utilized, all additional signing, labor, traffic control devices, or incidentals will not be paid for directly, will be considered incidental to the appropriate 652 items.

On roadways with immediately adjacent shoulders, the Contractor shall remove the pavement surface in each lane per the conditions in Table 2, unless otherwise noted by the Department in Special Provision, Section 105 – Limitations of Operations.

TABLE 2: MILLING CONDITIONS FOR THE EDGE OF TRAVELED WAY

Depth (At Edge of Traveled Way)	Conditions
2” and less	The Contractor may leave a vertical edge joint exposed for up to 21 days after milling is performed. The Contractor shall treat vertical edge joints exposed beyond 21 days per the criteria below.
Greater than 2”	The Contractor shall treat vertical edge joints exposed per the criteria below.

When required by Table 2, the Contractor shall treat vertical edge joints through one of the options below:

1. The vertical edge shall be tapered to a zero edge by means of milling a 12:1 transition from the edge of traveled way onto the shoulder before opening the lane to traffic. Tapers shall be removed to form a vertical edge prior to the placement of the new pavement course. No additional payment will be made for tapers, or taper removal.
2. An additional 2 feet of pavement shall be removed from the shoulder to eliminate the vertical edge at the edge of travelway before opening the lane to traffic. Unless otherwise authorized by the Department, no additional payment will be made for the additional milling.
3. A pavement layer shall be placed to reduce the vertical edge to 1 inch or less before opening the lane to traffic.

As a minimum, the use of temporary painted line, or RPMs placed along the edge of traveled way at 200 foot intervals is required for all elevation differentials. When pavement milling is extended into the shoulder (including milled tapers), appropriate channelization devices shall be placed 2 feet outside the edge of the vertical face at intervals not exceeding 600 feet, and RPMs shall be placed on the remaining pavement surface along the vertical edge at 200 foot intervals. Uneven pavement signs shall be placed at a maximum spacing of ½ mile when any pavement milling operations leaves an exposed uneven pavement surface.

Weepers shall be ground across the full width sections adjacent shoulders or remaining pavement surface matching the milled travel way or shoulder milled depth to minimize water ponding in any lanes carrying traffic. Weepers shall typically be 18 - 24" inches in width, installed along each lane, at a frequency of approximately one per half mile at locations as directed by the Resident or in areas that will provide drainage for the milled areas. Installation of weepers will not be paid for directly but will be considered incidental to the contracts pavement removal item. The replacement of mix in the weeper locations shall be performed concurrently within the pavement placement operation closure using the appropriate HMA item produced for the Contract or a MaineDOT approved 9.5mm HMA. There will be no separate payment for repaving the weeper locations as they are considered incidental to the square yard price of the contracts pavement removal item.

The milled surface shall be cleaned of all material resulting from the pavement removal operation. Loaders, skid steers, motorized side cast brooms, sweeper pick up brooms, vacuum pick up machines and hand labor may be used in any number or sequence as determined by the Contractor in order to clean the milled surfaces to the satisfaction of the Department before acceptance and opening the area up to traffic. The use of compressed air may be required to loosen any bonded materials from the surface to aid in cleaning.

Any areas of concern, such as de-lamination or pot-holing shall be identified on a continuous basis as milling progresses. Proper corrective action will be determined by the Resident and paid for under the appropriate contract items, and if required, completed prior to opening lane to traffic. Any issues that arise up to 7 calendar days after being milled will be the responsibility of the MaineDOT unless otherwise noted in Special Provision Section 105 – Limitations Of Operations.

Contractor Quality Control

Quality Control The Contractor shall develop and submit a Quality Control Plan (QCP) that addresses the methods to be used, equipment to be used, work accomplished (quantity measurements and tracking) as well as methods of cleaning and protection of the work as it is completed. The Contractor shall control the work and operate in accordance with the approved QCP in order to complete work meeting the contract requirements. The Contractor shall not begin pavement removal operations until the Department approves the QCP in writing.

Quality Control The QCP shall meet the requirements of Section 106.6 – Acceptance and this Section. The QCP shall address any items that affect the quality of the operation, and shall include the following personnel meeting these minimum requirements:

- a. QCP Administrator – The QCP Administrator must be a full-time employee of or a consultant engaged by the prime contractor or pavement removal subcontractor. The QCP Administrator shall have full authority to institute any and all actions necessary for the successful implementation of the QCP. The QCP Administrator (or their designee in the QCP Administrator’s absence) may not be required to be onsite during all work activities but shall be available to communicate with the Department as needed.
- b. Onsite Representative - The Onsite Representative (OR) shall be onsite and work directly with the crew as needed. The OR shall perform quality control inspections or measurements at the job site to assure that layout, pavement removal depth, width, profile and final surface tolerance meet the requirements of the contract.

The QCP shall detail the coordination of the activities of the Plan Administrator, and the OR. The Superintendent shall be named in the QCP if different than the OR, and the responsibilities for successful implementation of the QCP within the companies’ activities shall be outlined.

The QCP shall address any items that may impact the quality of pavement removal activities and final milled pavement surface including, but not limited to, the following:

a. General Requirements:

- Name of QCP Administrator
- Description of corrective action processes
- Remediation of defective work

b. Quality Control Plan requirements

- Name of Onsite Representative(s)
- Equipment make and model (including product sheet)
- Width of cutting drum
- Automation make, model and series (including product sheet)

- Describe automation set up, including methods to ensure pavement removal operations meet the requirements of the contract using control points, reference points, and cut points as well as any slope or cut depth transitions.
- Describe project layout, including centerline and any edge cut control, any off-set control layout to maintain or recreate centerline or edge cut control, cross slope transitions, or variable depth transitions required to perform the work
- Procedures to remove pavement surface to the required depth, width and profile
- Procedures to monitor pavement removal activities to ensure the final milled surfaces meet surface tolerance and texture requirements
- General cleaning operation activities including equipment to be used to sweep, vacuum and prepare surfaces for traffic use
- Procedures to ensure that traffic can transition from the milled to non-milled surfaces safely.
- Procedures to protect the milled surfaces from deterioration from construction activities, traffic or weather impacts

A summary of the day’s results including a quantity report, equipment used, and environmental conditions will be recorded and signed by the OR and presented to the Department’s representative by 1 PM the following working day.

Failure to adhere to the QCP, replace or repair defective or non-conforming equipment, or adjust material or installation procedures in an effort to produce work that meets the contract requirements will result in a notification of a quality control violation resulting in monetary penalties.

A letter describing the violation shall be provided to the Contractor which will result in a mandatory work suspension and a reduction in payment as shown in Table 106.4A below. The Contractor shall submit a letter to the Department that details the corrective action made to address the violation(s) in its Quality Control Plan. Work may resume when the Department is satisfied the corrective action will result in adherence to the Quality Control Plan.

Table 106.4 A - Quality Control Pay Reduction

Quality Control Plan Value*		Pay Reduction		
From More Than	To and Including	1st	2nd	3rd & Subsequent
\$0	\$500,000	\$1,000	\$2,000	\$4,000
\$500,000	\$1,000,000	\$2,000	\$4,000	\$8,000
\$1,000,000	\$3,000,000	\$5,000	\$10,000	\$20,000
\$3,000,000	and more	\$10,000	\$20,000	\$40,000

* The Quality Control Plan Value is the total Bid value of all items covered by a Quality Control Plan, as detailed in the applicable specification or Special Provision.

Pay reductions for failure to comply with the approved QCP are cumulative, and the Department will deduct any pay reductions from amounts otherwise due the Contractor. These pay reductions are intended to encourage the Contractor to comply with its approved QCP, and are not necessarily related to the quality of the work provided.

Basis of Payment

The square yard or hourly rental contract price will be full compensation for development and submittal of the QCP, mobilizing to the site, de-mobilizing from the site, labor, supervision, cleaning of the milled surface, management of the items covered by the QCP, and all other incidentals required to complete the work. Hauling and stockpiling of the material will not be paid for directly, but will be considered incidental to the milling items.

Square Yard: Payment will be made at the contract unit price for the number of square yards removed.

Hourly: Payment will be made at the contract unit price for the number of hours of operation removing pavement surface as directed by the Resident. The equipment used for pavement removal shall be operated at the minimum speed of 50 fpm, unless the Resident directs otherwise for milled surface quality reasons, or traffic control limitations impact pavement removal operations, or site conditions make operations at the prescribed rate unreasonable. Trimming to create a vertical face along curb line, guardrail, or around structures will be considered incidental to the 202.202 items. Additional trimming beyond the incidental work described will be paid under the appropriate rental items as listed in the Contract.

Pay Item

Pay Unit

202.202 Removing Pavement Surface
202.20201 Removing Pavement Surface (Hourly)

S.Y.
Hour

**SPECIAL PROVISION
SECTION 203
EXCAVATION AND EMBANKMENT
(CONTAMINATED SOIL AND GROUNDWATER MANAGEMENT)**

General The work under this specification shall be performed in conformance with the procedures and requirements described herein for the following activities: contaminated soil handling, reuse, temporary stockpiling, transportation, storage and disposal and, contaminated water handling, storage, treatment and disposal. This specification also addresses contaminated soil location, identification, and classification. The intent of this specification is to ensure that any contaminated soil and/or water encountered during construction will be managed in a manner that protects workers’ health and safety, public welfare and the environment.

Environmental Site Conditions The Maine Department of Transportation Environmental Office (MaineDOT-ENV) conducted a series of assessments related to the Route 202/201/201S Highway Reconstruction Project in Augusta, ME. An initial Phase I Environmental Assessment for the project area was completed to obtain a general understanding of the environmental conditions along the project corridor. Data garnered from this assessment was used to design a Modified, Phase II Contamination Assessment for the project. The primary focus of the assessments was to evaluate the type and extent of subsurface contamination along the project corridor. The Phase I Assessment included a review of relevant Maine Department of Environmental Protection (MDEP) and Environmental Protection Agency (EPA’s) databases, and field reconnaissance of the project area. During Phase II, auger borings were advanced at select, strategic locations for investigative purposes. Using data gathered from the advancement of borings, and previous work by others, three areas with impacted soil were identified. A photo-ionization detector (PID) was used to test soil grab samples from borings for Volatile Organic Compound (VOC) concentrations indicative of petroleum products. (See **Identified Areas of Contamination** below). Select samples for laboratory testing were also collected to further aid in evaluating subsurface conditions. Results of these investigations are available for review from the Senior Geologist at MaineDOT-ENV in Augusta (207-624-3000).

Identified Areas of Contamination The MaineDOT-ENV investigation identified three areas of soil contamination associated with the Augusta - Route 202/201/201S Highway Reconstruction Project. For reference, these areas are designated as “Area A”, “Area B”, and “Area C”.

Area A

The location of **Area A** is defined as adjacent to The Gun Shop, Aroma Joe's, and Kitchen EnCounters located at 1, 2, and 3 Bangor Street on the northeast and northwest boundaries of the Cony Circle Rotary. Specifically, **Area A** is defined as both right and left of centerline (north and southbound sides of Bangor Street), approximately between MaineDOT Survey Station 5001+00 to Station 5004+00. Soil screened with a PID in three of the four borings advanced within this area detected elevated VOCs. Specifically, field samples screened with a PID ranged from Non-Detect (ND) to 560 parts per million (ppm). Field observations indicated a very strong "hydrocarbon-like" odor.

Laboratory results for soil samples collected from within **Area A** and submitted for laboratory analysis of **Volatile Organic Compounds (VOCs)**, **Volatile Petroleum Hydrocarbons (VPH)**, **Extractable Petroleum Hydrocarbons (EPH)**, and **Total Lead**.

VOCs: Individual VOCs were either ND or did not exceed MDEP Remedial Action Guidelines (RAGS) for Petroleum Contaminated Sites - Excavation/Construction Worker Action Levels.

VPH: Soils from within **Area A** exhibited C5-C8 Aromatic Hydrocarbons (Adjusted) – 780 mg/kg. This concentration exceeds the MDEP Construction Worker RAGS concentration of 430 mg/kg. Other individual VPH compounds were detected, however none exceeded MDEP RAGS – Excavation/Construction Worker Action Levels.

EPH: Soils submitted for laboratory analysis of EPH were either ND or below Excavation/Construction Worker Action Levels.

Total Lead: Peak concentration – 24.2 mg/kg. Below MDEP RAGS Excavation/Construction Worker Action Levels.

Area B

Area B is identified as adjacent to Damon's Beverage, located at 75 Bangor Street (northbound side of Route 201). **Area B** can be identified as the northbound side of Bangor Street, approximately between Sta. 5020+50 to Sta. 5023+00. Soil screened with a PID in two of four borings within **Area B** detected elevated VOCs. Laboratory results for soil samples collected within **Area B** detected elevated concentrations of VPH parameters.

Volatile Organic Compounds (VOCs): Individual VOCs were either not detected or did not exceed MDEP RAGS - Excavation/Construction Worker Action Levels.

Volatile Petroleum Hydrocarbons (VPH): Soils from within **Area B** exhibited C5-C8 Aromatic Hydrocarbons (Adjusted) – 510 mg/kg. This concentration exceeds the MDEP Construction Worker RAGS concentration of 430 mg/kg. Other individual VPH compounds were either ND, or if detected, did not exceed MDEP RAGS - Excavation/Construction Worker Action Levels.

Extractable Petroleum Hydrocarbons (EPH): Laboratory results for soil samples collected from within **Area B** and submitted for laboratory analysis were either ND or if detected did not exceed MDEP RAGS - Excavation/Construction Worker Action Levels.

Total Lead: Peak concentration – 7.25 mg/kg. Below MDEP Action Levels.

Area C

Area C is identified as adjacent to the Mobil gas station located at 101 Bangor Street on the southeast corner of the Bangor Street and North Belfast Avenue intersection. The proposed borings adjacent to this property could not be advanced due to existing and unmarked potential utilities. Based on the Phase I assessment, 101 Bangor Street has historically been identified as a retail gas station since at least 1969. Due to historic uses and storage of petroleum products and known releases at this location, there is the potential of encountering contamination within the work zones adjacent to this area. **Area C** is identified as the northbound side of Bangor Street between Sta. 5027+00 and Sta. 5029+00 and the south side of North Belfast Avenue between Sta. 6000+00 and Sta. 6001+00. As borings were not advanced adjacent to the Mobil gas station facility, field soil samples were not collected and therefore laboratory samples were not submitted.

Concentrations of detected compounds define soils in **Area A**, **Area B**, and **Area C** as potential **Special Waste** per State remedial guidelines. Special Waste requires specific handling/management, transportation, and disposal procedures. Soil contamination in **Area A**, **Area B**, and **Area C** appears to be related to historical use or current use (**Area C**) of the adjacent properties as retail gasoline facilities. Compounds detected in **Area A** and **Area B** appear to indicate a historical release(s) of a petroleum product(s) that impacted subsurface conditions at the site and within the MaineDOT ROW.

Identifying and Screening Contaminated Soil and Groundwater Within the contaminated section designated **Area A**, **Area B**, and **Area C**, excavated soils will be classified by the Resident (or a MaineDOT-ENV representative) based on PID field screening measurements following the **Excavation-Construction Worker Cleanup Scenario** as prescribed in Table 1 – Approved PID Field Cleanup and Notification Guidelines in **MaineDEP Standard Operating Procedure (SOP) TS004 – COMPENDIUM of FIELD TESTING of SOIL SAMPLES for GASOLINE and FUEL OIL (10/15/2012)**.

Excavated soils within **Area A**, **Area B**, and **Area C** shall be classified as Group 1, Group 2, or Group 3.

Group 1 soils shall have PID field screening measurements indicating relative concentrations of volatile organic compounds (VOCs) less than or equal to 10 ppm as measured in 200-gram bag-headspace sample and an “Undetected” result using an oleophilic dye test.

Group 2 soils shall have PID field screening measurements indicating VOC concentrations greater than 10 ppm as measured in a 200-gram bag-headspace sample and less than the value indicated in Table 1 of SOP-TS004 when screened in accordance with the **Excavation-Construction Worker Cleanup Scenario** OR indicate a “Slightly Positive” result using an oleophilic dye test.

Group 3 soils shall exceed the threshold limit stated in the TS004 Compendium of Field Testing of soil samples exceeding the **Excavation-Construction Worker Cleanup Scenario** or indicate a “Saturated” / “Positive” result using an oleophilic dye test.

Handling and Disposition of Soil Materials Within **Area A, Area B, and Area C**, soil material excavated during construction shall be handled as follows:

Group 1 soils are not considered contaminated. Thus, special handling and disposal are not required for Group 1 Soils.

Group 2 soils shall be placed back into their excavation section of origin. The Contractor shall make every attempt to side cast any Group 2 soils next to the excavation site. Upon completion of the given constructional feature, Group 2 soils shall be placed back into the excavation up to 2 feet below ground surface. Group 2 materials not handled in this manner shall be considered Surplus Group 2 soils. Surplus Group 2 soils must be disposed of or treated at a facility licensed by the MDEP to accept petroleum contaminated special waste. The Contractor is solely responsible for obtaining associated permits and approvals for disposal or treatment of the Surplus Group 2 soils from relevant Municipal, State, and Federal agencies at no additional cost to the State. Notification shall be given to the Resident once approval is granted for the acceptance of this material at the off-site facility. No removal of Surplus Group 2 soil from the project shall occur without prior approval by the Resident. If any Surplus Group 2 soils cannot be transported to the pre-approved, properly licensed facility within 8 hours of their excavation, they must be placed in a Temporary Secure Stockpile Area somewhere within the project limits (See Temporary Secured Stockpile Area below).

Group 3 soils shall not be excavated without prior approval by the Resident. The Contractor shall arrange and undertake disposal of all Group 3 soils at a landfill or treatment facility licensed to accept petroleum contaminated special waste. The Contractor is responsible for all additional testing required by the receiving facility. Group 3 soils that cannot be disposed of within 8 hours of excavation shall be stored in a Temporary Secured Stockpile area. If the Contractor proposes other disposal or treatment options, the Contractor is solely responsible for obtaining the associated permits and approvals from relevant Municipal, State, and Federal agencies at no additional cost to the State.

The Resident is responsible for signing any manifests or bills of lading required to transport and dispose of contaminated soil. The Resident will send all manifests and bills of lading to MaineDOT, Environmental Office, Station 16, Augusta, Maine 04333.

Trench and Underdrain/Stormdrain Design in Contaminated Sections In Area A, Area B, and Area C, solid, Option III, non-perforated pipe shall be used in replacement of perforated underdrain pipe to help prevent the infiltration and transportation of potentially contaminated groundwater within the underdrain/stormdrain system. The Contractor shall backfill around the pipe and trenches in this section with uncontaminated material. Backfilling of the trench shall be in accordance with Section 206.03. All stones larger than 3 inches, frozen lumps, dry chunks of clay or any other objectionable matter shall be removed before backfilling.

Seepage control dikes (SCD) shall be installed roughly every 60 feet along the stormwater pipe trench.

SCDs shall consist of a mineral clay material with a liquid limit of equal to or greater than 24 and a natural moisture content of at least 20 percent. The clay should be placed in dry excavations in 6-inch maximum, thick lifts and compacted to 90% of the maximum dry unit weight as determined by AASHTO T99 (Standard Proctor). The SCDs shall be 5 feet long, be in intimate contact with the trench floor, trench walls and circumference of the pipe and extend up to the bottom of the road base. The excavated existing road base or similar material may be placed on top of the SCDs. The Contractor shall take care to ensure that no voids or uncompacted soil is left beside or beneath the Option III culvert pipe.

Secured Stockpile Area Direct transport of Surplus Group 2 or Group 3 soils to a pre-approved management facility is recommended. However, should the Contractor temporarily store any Surplus Group 2 or Group 3 soils at the site for more than 8 hours following excavation, they must be placed into a properly constructed Temporary Secured Stockpile Area. The Temporary Secured Stockpile Area must be constructed as defined herein and must be approved by the Resident prior to its use.

Should the Contractor utilize a Temporary Secured Stockpile Area, they shall install a continuous 0.3-meter-high compacted soil berm around the Secured Stockpile. The Secured Stockpile shall be placed on a liner of 20-mil polyethylene and securely covered with 20-mil polyethylene. The polyethylene liner and cover shall be placed over the soil berm and be installed to ensure that precipitation water drains directly to the outside of the berm perimeter while leachate from the contaminated soil is retained within the stockpile. The Secured Stockpile and soil berm shall be enclosed within a perimeter of concrete Jersey barriers or wooden barricades. The area within the Jersey barriers (or wooden barricades) shall be identified as a "restricted area" to prevent unauthorized access to the contaminated soil.

Secured Stockpile Area - Materials

A. Polyethylene. Polyethylene used for liner in the Secured Stockpile Area shall have a minimum of 20-mil thickness and shall meet the requirements of ASTM D3020.

B. Common Borrow. Fill used in the construction of the Temporary Secured Stockpile Area soil berm shall consist of Common Borrow and meet the requirements of Section 703.18

C. Concrete Barriers or Wooden Barricades. Concrete barriers or Wooden Barricades to form the sides of the Temporary Secured Stockpile Area shall meet the requirements of Section 526 or 652.05.

Health and Safety/Right-to-Know Contractors and subcontractors are required to notify their workers of the history of the site and contamination that may be present and to be alert for evidence of contaminated soil and groundwater. The Contractor shall notify the Resident **at least three business days** prior to commencing any excavation in **Area A, Area B, or Area C.**

The Contractor shall prepare a site-specific Health and Safety Plan (HASP) for its workers and subcontractors who may work in the contaminated areas of the site. A Qualified Health and Safety Professional shall complete the HASP. The Qualified Health and Safety Professional will be an expert in field implementation of the following federal regulations:

29 CFR 1910.120 or 29 CFR 1926.65	Hazardous Waste Operations and Emergency Response
29 CFR 1910.134	Respiratory Protection
29 CFR 1926.650	Subpart D - Excavations
29 CFR 1926.651	General Requirements
29 CFR 1926.652	Requirements for Protective Systems

MaineDOT is voluntarily ameliorating contamination in **Area A, Area B, and Area C.** Remedial efforts defined herein have been reviewed and approved by MDEP. Given that this is a voluntary clean up effort approved by a regulatory agency, OSHA requirements as defined in 29 CFR 1910.120 apply. These requirements mandate that workers and any subcontractors working in the contaminated areas shall comply with all OSHA regulations for Hazardous Waste Operations and Emergency Response including a 40-hour initial hazardous waste operations certification [OSHA 1910.120(e)], annual 8-hour refresher course within the last 12 months and medical surveillance [OSHA 1910.120(f)] within the last 12 months.

The Contractor shall designate a person to provide direct on-site supervision of the work in the contaminated areas. This person shall have the training under OSHA 1910.120 (e) as above and in addition be qualified as a construction Competent Person. It is the responsibility of the competent person to make those inspections necessary to identify situations that could result in hazardous conditions (e.g., possible cave-ins, indications of failure of protective systems, hazardous atmospheres, or other hazardous conditions), and then to ensure that corrective measures are taken.

Submittals The Contractor shall submit a site-specific HASP to the Resident at least two weeks in advance of any excavation work on the project. The Contractor shall not proceed with work until MaineDOT has reviewed the plan and notified the Contractor that it is acceptable.

Health and Safety Monitoring Within the contaminated areas of the project, the Contractor's designated on-site person shall monitor the worker breathing zone for those constituents specified in the Contractor's HASP. The Contractor shall provide all required health and safety monitoring equipment.

Dewatering Groundwater may be encountered and its removal necessary to complete work within **Area A**, **Area B**, and **Area C**. This groundwater will be treated as "contaminated" water. The Contractor shall inform the Resident before any dewatering commences. "Contaminated" water shall be pumped into a temporary holding tank(s). The Contractor will be responsible for the procurement of any holding tank(s). Any testing, treatment and/or disposal of the stored, petroleum-contaminated water shall be undertaken by the Contractor in accordance with applicable Federal, State and local regulatory requirements.

On-Site Water Storage Tanks – Materials If dewatering within the identified contaminated area becomes necessary, the holding tanks used for temporary storage of contaminated water pumped from excavations shall be contamination free and have a minimum capacity of 2,000 gallons.

Dust Control The Contractor shall employ dust control measures to minimize the creation of airborne dust during the construction process in potentially contaminated areas. As a minimum, standard dust control techniques shall be employed where heavy equipment and the public will be traveling. These may include techniques such as watering-down the site or spreading hygroscopic salts.

Unanticipated Contamination If the Contractor encounters previously undiscovered contamination or potentially hazardous conditions related to contamination, the Contractor shall immediately suspend work and secure the area. The Contractor will then notify the Resident immediately. These potentially hazardous conditions include, but are not limited to, buried containers, drums, tanks, "oil saturated soils", strong odors, or the presence of petroleum sufficient to cause a sheen on groundwater. The area of potential hazard shall be secured to minimize health risks to workers and the public and to prevent

the release of contaminants into the environment. The source of any suspected contamination shall be evaluated by the Resident (or MaineDOT's -ENV representative). As appropriate, the Resident will notify the MDEP's Response Services Unit in Augusta and MaineDOT-ENV. The Augusta Fire Department must also be notified prior to removal of buried storage tanks and associated piping. The Contractor will evaluate the impact of the hazard on construction, amend the HASP if necessary, and with the Resident's approval, recommence work in accordance with the procedures of this Special Provision.

Method of Measurement There will be no measurement for identification and environmental screening of contaminated soil material (this will be done by the Resident or MaineDOT-ENV representative).

Measurement for the development of a Health and Safety Plan (HASP) and providing health and safety equipment and personnel shall be by lump sum.

Measurement of the off-site treatment or disposal of Surplus Group 2 and Group 3 soils will be by the ton of Special Excavation.

There will be no measurement for construction of a Temporary Secured Stockpile Area. Construction of a Temporary Secured Stockpile Area, if necessary, is considered incidental to project construction. There will be no measurement for hauling Surplus Group 2 material or Group 3 soils to the Temporary Secure Stockpile area or placement and removal of Surplus Group 2 or Group 3 soils in or out of the Temporary Secure Stockpile area. Hauling and any subsequent management/placement of contaminated soils are considered incidental to project construction.

There will be no measurement for additional laboratory testing of contaminated soil that is required by the landfill or treatment facility. Testing is incidental to the disposal of Special Excavation.

Measurement for the following items shall be according to Subsection 109:04 ("Change Order"/Force Account): any necessary contaminated water holding tank(s); and treatment or disposal of any contaminated groundwater.

Basis of Payment There will be no payment for the identification and environmental screening of contaminated soil material (this will be completed by the Resident or MaineDOT-ENV representative).

Payment for the development of a Health and Safety Plan (HASP) and providing health and safety equipment and personnel shall be by the lump sum (L.S.).

Payment for off-site disposal or treatment of contaminated Surplus Group 2 and Group 3 soils at a MDEP licensed facility shall be by the ton of Special Excavation.

There will be no payment for the construction of the Temporary Secured Stockpile Area or hauling/management/placement of contaminated soils to the Temporary Secured Stockpile Area. The Temporary Secured Stockpile Area shall be considered incidental to project construction.

Payment for the following items shall be according to Subsection 109:04 (“Change Order”/Force Account): any necessary contaminated water holding tank(s); and treatment or disposal of any contaminated groundwater.

Pay Item		Pay Unit
203.2312	Health and Safety Plan (HASP)	Lump Sum
203.2333	Disposal/Treatment of Special Excavation	Ton

SECTION 401 - HOT MIX ASPHALT PAVEMENT

401.01 Description The Contractor shall furnish a uniformly blended, homogeneous mixture placed as one or more courses of Hot Mix Asphalt Pavement (HMA) using a single approved design for each item on an approved base in accordance with the contract documents and in reasonably close conformity with the lines, grades, thickness, and typical cross sections shown on the plans or established by the Resident. The Department will accept this work under Quality Assurance provisions, in accordance with these specifications and the requirements of Section 106 – Quality, the provisions of AASHTO M 323 except where otherwise noted in sections 401 and 703 of these specifications, and the MaineDOT Policies and Procedures for HMA Sampling and Testing.

401.02 Materials Materials shall meet the requirements specified in Section 700 - Materials:

Asphalt Cement	702.01
Aggregates for HMA Pavement	703.07
RAP for HMA Pavement	703.08
HMA Mixture Composition	703.09

401.03 Composition of Mixtures The Contractor shall compose the Hot Mix Asphalt Pavement with aggregate, Performance Graded Asphalt Binder (PGAB), approved antistrip, warm mix additive, and/or mineral filler if required. HMA shall be designed and tested according to AASHTO R 35 and the volumetric criteria in Table 1. The Contractor shall size, uniformly grade, and combine the aggregate fractions in proportions that provide a mixture meeting the grading requirements of the Job Mix Formula (JMF). Unless otherwise noted in Special Provision 403 - Hot Mix Asphalt Pavement, the design, verification, Quality Control, and Acceptance tests for this mix will be performed at 65 gyrations.

TABLE 1: VOLUMETRIC DESIGN CRITERIA

Design ESAL's (Millions)	Required Density (Percent of G _{mm})			Voids in the Mineral Aggregate (VMA) (Minimum Percent)					Voids Filled with Binder (VFB) (Minimum %)	Fines/Eff . Binder Ratio
				Nominal Maximum Aggregate Size (mm)						
	N _{initial}	N _{design}	N _{max}	25.0	19.0	12.5	9.5	4.75		
< 3.0	≤90.5									
3 to <10	≤89.0	96.0	≤98.0	13.0	14.0	15.0	16.0	16.0	65-80*	0.6-1.2
≥ 10										

*For 9.5 mm nominal maximum aggregate size mixtures, the maximum VFB is 82. For 4.75 mm nominal maximum aggregate size mixtures, the maximum VFB is 84.

The Contractor shall submit a JMF to the Department for each mixture to be supplied. The JMF will be approved by the Department in accordance with the MaineDOT HMA Policies and Procedures for HMA Sampling and Testing Manual. At the time of JMF submittal, the Contractor shall identify and make available the stockpiles of all proposed aggregates at the plant site. There must be a minimum of 150 ton for coarse aggregate stockpiles and 75 ton for fine aggregate stockpiles before

the JMF may be submitted. The Contractor shall provide aggregate samples to the Department unless otherwise required. The Contractor shall also make available to the Department the PGAB proposed for use in the mix in sufficient quantity to test the properties of the asphalt and to produce samples for testing of the mixture. The first day’s production shall be monitored, and the approval may be withdrawn if the mixture exhibits undesirable characteristics such as checking, shoving or displacement. The Contractor shall be allowed to submit aim changes for a JMF as outlined in the MaineDOT HMA Policies and Procedures for HMA Sampling and Testing Manual: Mix Design Approval Section.

The Contractor shall submit a new JMF for approval each time a change in material source or materials properties is proposed. The same approval process shall be followed. The cold feed percentage of any aggregate may be adjusted up to 10 percentage points from the amount listed on the JMF, however no aggregate listed on the JMF shall be eliminated. The cold feed percentage for RAP may be reduced up to 10 percentage points from the amount listed on the JMF and shall not exceed the percentage of RAP approved in the JMF or for the specific application under any circumstances.

401.031 Warm Mix Technology The Contractor may place Hot Mix Asphalt Pavement produced with an accepted WMA technology if approved by the Department. Methods or technologies shall generally be at the Contractors option, but will be limited to proven, Agency and Industry accepted practice. Mixture production, placement and volumetric testing details, including temperatures, shall be included in the project specific QCP, and submitted to the Department for approval prior to any work.

401.04 Temperature Requirements The temperature of the mixture shall conform to the tolerances in Table 2 as measured at the truck at the mixing plant and at the paver unless otherwise authorized by the Department.

TABLE 2: ALLOWABLE TEMPERATURE RANGES

PGAB Grade(s)	Temperature Range (°F)
PG58-28 / PG64-28	275-325
PG64E-28 / PG70E-28	285-335

401.05 Performance Graded Asphalt Binder The Contractor shall utilize either a PG58-28, PG64-28, PG64E-28, PG70E-28, or other grade as specified in the 403 Special Provision. The Contractor shall utilize a PG64-28 if no liquid grade is specified within the 403 Special Provision.

401.06 Weather and Seasonal Limitations The State is divided into two paving zones as follows:

- a. Zone 1 Areas north of US Route 2 from Gilead to Bangor and north of Route 9 from Bangor to Calais.
- b. Zone 2 Areas south of Zone 1 including the US Route 2 and Route 9 boundaries.

TABLE 3: SEASONAL AND TEMPERATURE LIMITATIONS

Description	Zone 1 Allowable Placement Dates	Zone 2 Allowable Placement Dates	Minimum Ambient Air Temperature
HMA Surface Course greater than or equal to 1” (Travelway)	May 1 to Saturday following October 1	April 15 to Saturday following October 15	50°F
HMA Surface Course less than 1” (Travelway)	May 15 to Saturday following September 15	May 15 to Saturday following October 1	
HMA Surface Course less than 1” considered to be “Night Work” (Travelway)	June 1 to the Saturday following September 1		
HMA Surface Course less than 1” (Shoulders)	May 15 to the Saturday following October 15		
HMA for Surface Course on Bridge Decks	May 1 to Saturday following October 1	April 15 to Saturday following October 15	
HMA for Base or Shim Course on Bridge Decks	April 15 to November 15		
HMA for use other than Travelway Surface Course (Shoulders greater than or equal to 1”, Intermediate, Base, Shim)	April 15 to November 15		40°F
HMA for curb, driveways, sidewalks, islands, or other incidentals	N/A		
With Use of Approved Warm Mix Technology as Compaction Aid (Surface Course Ambient Air Temperature Allowances)			
HMA Surface Course greater than or equal to 1” (Travelway)	May 1 to Saturday following October 1	April 15 to Saturday following October 15	Begin at 50°F and pave down to 45°F
HMA Surface Course less than 1” (Travelway)	May 15 to Saturday following October 1	May 15 to Saturday following October 15	
HMA Surface Course less than 1” considered to be “Night Work” (Travelway)	June 1 to the Saturday following September 15		
HMA Surface Course less than 1” (Shoulders)	May 15 to the Saturday following October 15		
With Use of Approved Warm Mix Technology as Compaction Aid (Seasonal Limitation Extensions)			
HMA Surface Course greater than or equal to 1” (Travelway)	Saturday following October 1 to Saturday following October 15	Saturday following October 15 to Saturday following October 29	50°F
HMA Surface Course less than 1” (Shoulders)	Saturday following October 15 to Saturday following October 29		
HMA for use other than Travelway Surface Course (Shoulders greater than or equal to 1”, Intermediate, Base, Shim)	April 15 to Saturday following November 15		35°F

1. Shoulders paved with the travelway pass shall meet travelway ambient air temperatures
2. Refer to the 461 SP for UTBWC for seasonal and temperature requirements.
3. The minimum ambient air temperature for placement of HMA for curbs, driveways, sidewalks, islands, and other incidental work shall be 40°F, regardless of whether the mixture is produced using an approved WMA technology.

The ambient air temperature shall be determined by an approved thermometer placed in the shade at the paving location. Unless otherwise specified, the Contractor shall not place Hot Mix Asphalt Pavement on a wet or frozen surface regardless of the ambient air temperature. The Hot Mix Asphalt Pavement produced with an approved WMA technology shall meet the requirements of section 401.04 - Temperature Requirements, unless otherwise approved by the Department. For the purposes of this Section, the traveled way includes truck lanes, ramps, approach roads and auxiliary lanes.

401.07 Hot Mix Asphalt Plant

401.071 General Requirements HMA plants shall conform to AASHTO M 156, Standard Specification for Requirements for Mixing Plants for Hot-Mixed, Hot-Laid Bituminous Paving Mixtures with exception of Section 4.2.1, 4.2.2, 4.3.4, 4.3.5, and 4.12.2.

All HMA plants will be inspected annually by the Department prior to producing HMA for Department projects. The Contractor shall provide the Department at least 72 hours' notice that the plant is ready for inspection. The Contractor shall equip the plant with ladders and platforms that are accessible and safe to obtain samples of PGAB, aggregate and mix from the relevant tanks, collector belts and haul units. Silo storage time of mixtures shall not exceed 36 hours.

401.072 Stockpiles The Contractor shall provide sufficient space for stockpiles and maintain a minimum of supply for 2 days production of all aggregate products used in MaineDOT approved mix designs currently under production. A minimum stockpile supply of 100 ton (70 yards) shall be maintained at all times. The Contractor shall construct stockpiles to prevent intermingling and to minimize segregation. All stockpiles used in MaineDOT mixes shall be identified with weatherproof signs at least 12" high and 24" wide, with reflective lettering at least 2" high.

401.073 Cold Feeds Cold Feed Bins will have bin dividers to keep aggregate products separated. Adequate means must be provided for obtaining samples of the combined flow of all Cold feed bins.

401.074 Dryer Dryer shall be capable of heating aggregate to required mixing temperature and shall be in good operation and condition. Dryer shall be subject to annual inspection prior to start-up. The Contractor shall dry and heat the aggregates for the HMA to the required temperature, adjusting flames to avoid damaging the aggregates. The Contractor shall provide the Department a minimum period of 72 hours to inspect the dryer and provide at least 24 hours' notice that the dryer is ready for inspection.

401.075 Asphalt Binder The plant shall include a heating system and insulation to maintain the asphalt binder at a uniform temperature for proper mixing and compaction. A thermometer shall be provided in the asphalt binder line. No direct flame may come in contact with tank. A sampling valve shall be provided in the circulation line downstream of any binder additive used unless otherwise approved by the Department. The Contractor shall drain down the asphalt as low as safely possible in any tank that will be switched to a new source or grade prior to adding the new PGAB.

401.076 Additives Additives (WMA, anti-strip, etc.) introduced into the binder at the HMA plant shall be introduced per the supplier's recommendations and shall be approved by the Department. The system for introducing additives shall be interlocked with the aggregate feed or weigh system to maintain correct proportions for all production rates and batch sizes. Additive introduction systems shall be controlled by a proportioning device to the amount required on the JMF plus or minus 0.1% of the target. Additive introduction systems shall be interlocked with the plant and the recordation (batch tickets or drum recordation) shall display the additive and the weight and percentage added. A means for sampling the PG binder with additive introduced will be provided. The sampling point shall be after the additive is mixed with the PGAB before entering the drum or mixer unit.

401.077 Batch Plants

Hot Bins Hot bins shall provide uniform continuous operation and be in good working condition. The plant shall be able to provide samples of hot bins upon request. Overflow shall be provided for each hot bin. Hot bin gates shall close without leaking. Bin walls must prevent intermingling between bins. Each hot bin shall have low level indicators which will alert the operator when the bin is empty.

Mixer Unit Clearance between blades and liner shall be 1" maximum, unless the aggregate exceeds 1 ¼" then the clearance shall be 1 ½". The spray bar length shall be at least 75% of the mixer length. The mixer unit shall be a twin pug mill-type mixer capable of mixing continuously for at least 45 seconds after all materials have been introduced into the mixer. The blades in the mixer shall be capable of producing a homogenous mixture. If the mixer is not enclosed, it shall be equipped with an adjustable hood to prevent loss of dust by dispersion. The mixer unit shall be subject to annual inspection prior to removal of safety features and being readied for service. The Contractor shall provide the Department the opportunity to inspect the mixer unit prior to the annual inspection. The Contractor shall provide the Department a minimum period of 72 hours to inspect the mixer unit and provide at least 24 hours' notice that the mixer unit is ready for inspection.

Mineral Filler Mineral filler and fiber shall utilize separate bins and feed systems to store and proportion the required quantity into the mixture. The feed systems shall be accurate to no more than 10% of the required weight with a convenient and accurate means of calibration. Mineral filler and fiber shall be introduced in the weigh hopper and uniformly distributed prior to the injection of the asphalt binder.

Automation The HMA batch plant shall automatically batch, mix and discharges mixes. The batch plant shall accurately proportion the various materials in the proper order by weight. The entire batching and mixing cycle shall be continuous and shall not require any manual operations. The batch plant shall use auxiliary interlock circuits to trigger an audible alarm whenever an error exceeding the acceptable tolerance occurs. Along with the alarm, the printer shall print an asterisk on the delivery slip in the same row containing the out-of-tolerance weight. The automatic proportioning system shall be capable of consistently delivering material within the full range of batch sizes. When RAP is being used, the plant must be capable of automatically compensating for the moisture content of the RAP.

The HMA batch plant shall be operated within the following tolerances:

Each aggregate component	+/- 1.5% cumulative, per bin
Mineral Filler	+/- 0.5%
Bituminous Material	+/- 0.1%
Zero return (aggregate)	+/- 0.5%
Zero Return (AC)	+/- 0.1%
Additives	+/- 0.1%

Recordation All plants shall be equipped with an approved digital recording device. The printer shall mark any weight on the ticket that exceeds tolerance. The delivery slip shall contain information required under Section 108.1.3 - Provisions Relating to Certain Measurements, Mass and paragraphs a, b, and c of Section 401.078.

401.078 Drum Plants

Cold Feeds and Delivery System A scalper screen shall be used to remove oversize material. The accuracy of the belt scale shall be within +/- 1.0% of the actual weight being measured. The plant shall be capable of correcting for aggregate moisture. Mineral filler and fiber shall utilize separate bin(s) and feeder systems to store and proportion the required quantity into the mixture. The feed systems shall be accurate to no more than +/- 10% of the required weight with a convenient and accurate means of calibration. The plant shall be equipped with a single control to change all feed rates. Mineral filler and fiber shall be introduced such that dry mixing is accomplished no less than 18 inches prior to the injection of the asphalt binder. The Contractor shall ensure that the mineral filler does not become entrained in the exhaust stream of the dryer.

Binder System The flow of asphalt binder shall adjust automatically with dry aggregate weights. The Department will conduct an asphalt flow meter check annually and after each change of plant location. The flow meter check must be performed prior to producing mix for Department projects. The plant must be configured to provide a convenient means to check accuracy of the flow meter. The flow meter will be considered accurate if the measured weight is within 1% of actual weight.

Drum Mixer The plant shall be equipped with a diversion system where mix can be diverted at startup/shutdown and any time. The drum mixer shall be subject to annual inspection prior to removal of safety features and being readied for service. The Contractor shall provide the Department a minimum period of 72 hours to inspect the drum mixer while providing at least 72 hours' notice that the drum mixer is ready for inspection.

Recordation An approved automatic ticket printer system shall be used to print delivery slips. The requirements for delivery slips for payment of materials measured by weight, as given in the following Sections, shall be waived: 108.1.3 a., 108.1.3 b., 108.1.3 c., and 108.1.3 d. The automatic printed ticket will be considered as the Weight Certificate. The dry aggregate weights and binder flow shall be recorded as well as mineral filler and all binder additives. The recordation of materials shall be printed a minimum of every ten minutes while in production.

The requirements of Section 108.1.3 f. - Delivery Slips, shall be met by the delivery slip printed by the automatic system, which accompanies each truckload, except for the following changes:

- a. The quantity information required shall be individual weights of each batch or total net weigh of each truckload.
- b. Signatures (legible initials acceptable) of Weighmaster (required only in the event of a malfunction as described in 401.074 c.).
- c. The MaineDOT designation for the JMF.

401.079 Scales and Weight Checks Scales shall meeting the requirements of Section 108 - Payment. The scales shall be inspected and sealed by the State Sealer (or approved alternative) as often as the Department deems necessary to verify their accuracy. Plant scales shall be checked prior to the start of the paving season, and each time a plant is moved to a new location. Subsequent checks will be made as determined by the Resident. The Contractor will have at least ten 50 pound masses for scale testing at batch plants. At Contractor's option, the Contractor can use one single test weight that has been checked on sealed scales. This weight shall be 1,000 lbs. or greater. At least twice during each 5 days of production either of the following checks will be performed:

- a. A loaded truck may be intercepted and weighed on a platform scale that has been sealed by the State Sealer of Weights and Measures within the past 12 months. The inspector will notify the producer to take corrective action on any discrepancy over 1.0%. The producer may continue to operate for 48 hours under the following conditions.
 1. If the discrepancy does not exceed 1.5%; payment will still be governed by the printed ticket.
 2. If the discrepancy exceeds 1.5%, the plant will be allowed to operate as long as payment is determined by truck platform scale net weight.

If, after 48 hours the discrepancy has not been addressed and reduced below 1.0%, then plant operations will cease. Plant operation may resume after the discrepancy has been brought within 1.0%.

- b. Where platform scales are not readily available, a check will be made to verify the accuracy and sensitivity of each scale within the normal weighing range and to assure that the interlocking devices and automatic printer system are functioning properly. If platform scales are not readily available, a weight with a known mass-verified and sealed annually by a licensed scale company, may be used by hanging weight from silo or surge hopper, at lower middle and upper third levels upon request to verify scale accuracy.
- c. In the event of a malfunction of the automatic printer system, production may be continued without the use of platform truck scales for a period not to exceed the next two working days, providing total weights of each batch are recorded on weight tickets and certified by a Licensed Public Weighmaster.

401.08 Hauling Equipment Units hauling HMA shall have tight, clean, and smooth metal bodies, which have been thinly coated with a small amount of approved release agent to prevent the mixture from adhering to the bodies. Release agents that dissolve or strip asphalts, including diesel fuel, will not be allowed.

All mix haul units shall have a cover of water repellent material capable of heat retention, which completely covers the mixture. The cover shall be securely fastened on the truck, unless unloading. Haul units shall have an opening on both sides near the midpoint of the body, at least 12 in above the bed, which will accommodate a thermometer stem.

401.09 Pavers The Contractor shall use pavers meeting the requirements of this section unless otherwise authorized by the Department. Pavers shall meet the requirements of Table 4: Paver Requirements.

TABLE 4: PAVER REQUIREMENTS

Use	Paver Requirement
Traveled Way & Auxiliary Lanes	Equipped with a 10 ft minimum main screed with activated extensions. The minimum tractor weight shall be 30,000 pounds.
	Equipped with automatic grade and slope controls that automatically adjust the screed and increase or decrease the layer thickness to compensate for irregularities in the preceding course. The controls shall maintain the proper transverse slope and be readily adjustable so that transitions and superelevated curves can be properly paved. The controls shall operate from a fixed or moving reference such as a grade wire or ski type device (floating beam) with a minimum length of 30 ft, a non-contact grade control with a minimum span of 24 ft, except that a 40 ft reference shall be used on interstate and divided highway projects.
All HMA Placement	Self-contained, self-propelled units of sufficient class and size to place Hot Mix Asphalt Pavement in full lane widths specified in the contract on the main line, shoulder, or similar construction.
	Equipped with a free-floating activated heated main screed with activated extensions. Pavers with extendible screeds shall have auger extensions and tunnel extenders as per the manufacturer's recommendations, a copy of which shall be available if requested.
	Equipped with a receiving hopper with sufficient capacity for a uniform spreading operation and a distribution system to place the mixture uniformly, without segregation in front of the screed.
	Operated in such a manner as to produce a visually uniform surface texture and a thickness within the requirements of Section 401.11 - Surface Tolerances. The screed assembly shall produce a finished surface of the required evenness and texture without tearing, shoving, or gouging the mixture.

The Contractor shall have the paver at the project site sufficiently before the start of paving operations to be inspected and approved by the Department. The Contractor shall repair or replace any paver found worn or defective, either before or during placement, to the satisfaction of the Department. Pavers that produce an unevenly textured or non-uniform mat will be repaired or replaced before continuing to place HMA on MaineDOT projects. On a daily basis, the Contractor shall perform density testing across that mat as detailed in Section 401.191 Quality Control - Method A, B & C.

401.10 Rollers Rollers shall be static steel, pneumatic tire, oscillatory, or approved vibrator type. Rollers shall be in good mechanical condition, capable of starting and stopping smoothly, and be free from backlash when reversing direction. Rollers shall be equipped and operated in such a way as to prevent the picking up of hot mixed material by the roller drums or tires. Crushing of the aggregate or displacement of the HMA during rolling will not be permitted. Any HMA Pavement that becomes loose, broken, contaminated, shows an excess or deficiency of PGAB, or is in any other way defective shall be removed and replaced at no additional cost with fresh material which shall be immediately compacted to conform to the adjacent area.

The Contractor shall repair or replace any roller found to be worn or defective, either before or during placement, to the satisfaction of the Department. Rollers that produce grooved, unevenly textured or non-uniform mat will be repaired or replaced before continuing to place HMA. The type of rollers to be used and their relative position in the compaction sequence shall generally be the Contractor's option unless otherwise specified in the contract, provided specified density is attained and with the following requirements:

- a. On variable-depth courses, the first lift of pavement over gravel, reclaimed pavement, on irregular or milled surfaces, or on bridges, at least one roller shall be 16 ton pneumatic-tired. Pneumatic-tired rollers shall be equipped with skirting to minimize the pickup of HMA materials from the paved surface. When required by the Resident, the roller shall be ballasted to 20 ton.
- b. Compaction with a vibratory or steel wheel roller shall precede pneumatic-tired rolling, unless otherwise authorized by the Department.
- c. Vibratory rollers shall not be operated in the vibratory mode on bridge decks.
- d. Any method, which results in cracking or checking of the mat, will be discontinued and corrective action taken.
- e. The use of an oscillating steel roller shall be required to compact all mixtures placed on bridge decks.

The maximum operating speed for a steel wheel or pneumatic roller shall not exceed the manufacturer's recommendations, a copy of which shall be available if requested.

401.11 Surface Tolerances The Department will check the following surface tolerances:

- a. Longitudinally: The pavement surface profile shall be free of deviations in excess of +/- ¼ inches from the required pavement surface profile grade. To verify the surface tolerance a straight plane shall be established using 16 foot straight edge or a taught string line placed parallel to the direction of travel and checked continuously across the width of the lane.
- b. Transversely: The pavement surface profile shall be free of deviations in excess of 0 inches below and ¼ inches above the required cross-sectional profile grade. To verify the surface tolerance a straight plane shall be established using a 10 foot straight edge or taught string line placed perpendicular to the direction of travel and checked continuously along the length of the lane.

The Contractor shall correct defective areas by removing defective work and replacing it with new material as directed by the Department. The Contractor shall furnish a 10 foot straightedge for the Department's use.

401.12 Preparation of Existing Surface The Contractor shall thoroughly clean the surface upon which Hot Mix Asphalt Pavement is to be placed of all objectionable material. When the surface of the existing base or pavement is irregular, the Contractor shall bring it to uniform grade and cross section. All surfaces shall have a tack coat applied prior to placing any new HMA course.

When covering portland cement concrete surfaces (concrete slabs or concrete backfill), as a minimum, a triple application of tack coat shall be applied on the surface prior to pavement being placed over the concrete.

Tack coat shall conform to the requirements of Section 409 – Bituminous Tack Coat, Section 702 – Bituminous Material, and all applicable sections of the contract.

401.13 Spreading and Finishing In areas where irregularities or unavoidable obstacles make the use of mechanical spreading and finishing equipment impracticable, the Contractor shall spread, rake, and lute the HMA with hand tools to provide the required compacted thickness. Release agents that dissolve or strip asphalts, including diesel fuel, will not be allowed. On roadways with adjoining lanes carrying traffic, the Contractor shall place each course per the conditions in Table 5, unless otherwise noted by the Department in Section 403 - Hot Mix Asphalt Pavement.

TABLE 5: PLACEMENT CONDITIONS FOR ADJOINING LANES

Depth (at centerline)	Placement Conditions
Vertical Longitudinal Joint	
¾" and less (incl. shim)	The Contractor may place the HMA course over the full single travel lane width for each production day.
1" to 1 ¼"	The Contractor may place the HMA course over the full single travel lane width for each production day and will be required to place a matching course of HMA over the adjacent section of travel lane before weekend or holiday suspension. A maximum unmatched centerline joint of the project's 1 days' average production will be permitted over the weekend.
1 ½" to 2"	The Contractor may place the HMA course over the full single travel lane width for each production day and will be required to place a matching course of HMA over the adjacent section of travel lane before the end of the following calendar day.
Greater than 2"	The Contractor shall place each course over the full width of the traveled way section being paved that day.
Notched-Wedge Longitudinal Joint	
1 ½" to 2"	The Contractor may place the HMA course over the full single travel lane width for each production day and will be required to place a matching course of HMA over the adjacent section of travel lane before weekend or holiday suspension. A maximum unmatched centerline joint of the project's 1 days' average production will be permitted over the weekend.
Greater than 2"	The Contractor may place the HMA course over the full single travel lane width for each production day and will be required to place a matching course of HMA over the adjacent section of travel lane before the end of the following calendar day.
Longitudinal Joints (<45 mph) *	
Greater than 2"	With use of a Notch-Wedge device, the Contractor may place the HMA course over the full single travel lane width for each production day and will be required to place a matching course of HMA over the adjacent section of travel lane before weekend or holiday suspension. A maximum unmatched centerline joint of the project's 1 days' average production will be permitted over the weekend.

* Longitudinal joint allowances for segments under 45 mph will only be permitted if the segment length is continuous for one mile or greater or the total length of the project is one mile or less.

Constructed wedge joints that degrade or break off will not qualify for the open joint duration as described above. The impacted area shall be matched up within 48 hours of notification by the Department. Prior to matching, the Contractor shall trim off the impacted area and construct a vertical joint. Failure to comply will result in an automatic Traffic Control Violation as per section 652.8.

The Contractor shall place the specified course over the full width of the mainline traveled way being paved, regardless of use, depth, or longitudinal joint type prior to Memorial Day, July 4th, Labor Day, paving suspensions exceeding three days, or other dates as specified by special provision.

The Contractor shall install additional warning signage that clearly defines the centerline elevation differential hazard. Unless otherwise addressed in the contract, the Contractor shall install additional centerline delineation such as a double application of raised pavement markers at 100 foot intervals, or temporary painted line. For any exposed vertical edge between the shoulder and traveled way, at a minimum, the use of temporary painted line, or RPMs placed along the edge of traveled way at 200 foot intervals is required. The Traffic Control Plan shall be amended to include this option and the additional requirements. All signs and traffic control devices will conform to Section 719.01, and Section 652, and will be installed prior to the work, at a maximum spacing of 0.50 mile for the entire length of effected roadway section. If this option is utilized, all additional signing, labor, traffic control devices, or incidentals will not be paid for directly, will be considered incidental to the appropriate 652 items.

When covering a portland cement concrete surface (concrete slabs or concrete backfill) a minimum of 3 inches of HMA pavement will be required over the concrete.

401.14 Hot Mix Asphalt Placement on Bridge Decks Hot mix asphalt pavement placed on bridges shall also conform to Section 508.04 and the following requirements:

- a. The minimum production and placement temperature for the Hot Mix Asphalt placed over membrane shall conform to the manufacturer's recommendations.
- b. The bottom course shall be placed with an approved rubber mounted paver of such type and operated in such a manner that the membrane waterproofing will not be damaged in any way.
- c. The top course shall not be placed until the bottom course has cooled sufficiently to provide stability.
- d. The Contractor will not be required to cut sample cores from the compacted pavement on the bridge deck, unless otherwise directed by Special Provision.
- e. After the top course has been placed, the shoulder areas shall be sealed 3 ft wide with two applications of an emulsified bituminous sealer meeting the requirements of Section 612.03 - Sealing and Section 702.12 - Emulsified Bituminous Sealing Compound. The first application shall be pre-mixed with fine, sharp sand, similar to mortar sand, as needed to fill all voids in the mix in the area being sealed. The second application may be applied without sand. The sealer shall be carried to the curb at the gutter line in sufficient quantity to leave a bead or fillet of material at the face of the curb. The area to be sealed shall be clean, dry and the surface shall be at ambient temperature. The furnishing and applying of the required quantity of sealer for the bridge shoulder areas shall be incidental to placing the hot mix asphalt pavement.
- f. The area between the edge of the membrane and the vertical surface of bridge curbing and concrete bridge headers shall be completely sealed with hot-applied asphaltsealant material, meeting the requirements of Type 4 or mastic crack seal. Sealant shall be applied to form a complete seal between the membrane and the vertical surface and shall extend up the vertical surface to within ½ inch of the top of the HMA wearing surface. This work shall be considered incidental to the contract pavement items unless 508 membrane items are included in the contract.

401.15 Compaction Immediately after the Hot Mix Asphalt Pavement has been spread, struck off, and any surface irregularities adjusted, the Contractor shall thoroughly and uniformly compact the HMA by rolling.

The Contractor shall roll the surface when the mixture is in the proper condition and when the rolling does not cause undue displacement, cracking, or shoving. The Contractor shall prevent adhesion of the HMA to the rollers or vibrating compactors without the use of fuel oil or other petroleum-based release agents. Solvents designed to strip asphalt binders from aggregates will not be permitted as release agents on equipment, tools, or pavement surfaces.

The Contractor shall immediately correct any displacement occurring as a result of the reversing of the direction of a roller or from other causes to the satisfaction of the Department. Any operation other than placement of variable depth shim course that results in breakdown of the aggregate shall be discontinued. Any new pavement that shows obvious cracking, checking, or displacement shall be removed and replaced for the full lane width as directed by the Resident at no cost to the Department.

Along forms, curbs, headers, walls, and other places not accessible to the rollers, the Contractor shall thoroughly compact the HMA with mechanical vibrating compactors. The Contractor shall only use hand tamping in areas inaccessible to all other compaction equipment. On depressed areas, the Contractor may use a trench roller or cleated compression strips under a roller to transmit compression to the depressed area.

Any HMA that becomes unacceptable due to cooling, cracking, checking, segregation or deformation as a result of an interruption in mix delivery shall be removed and replaced with material that meets contract specifications at no cost to the Department.

For all items requiring pavement density testing, the Contractor shall cut 6-inch diameter cores at no additional cost to the Department by the end of the working day following paving. Cores shall be cut such that the nearest edge at least 9 inches from any joint. Pre-testing of the cores will not be allowed. If the Contractor and the Department mutually determine that a core is damaged, the Contractor shall cut new core(s) at the same offset and within 3 ft of the initial sample. The Contractor and the Department will mutually determine if underlying material is adhered to the core and if so will mark the core at the point where sawing is needed. The Department will place the cores in a secure container and the Contractor shall transport the cores to the designated MaineDOT lab. The cores will be saw cut by the Department to remove underlying layers. No recuts are allowed at a test location after the core has been tested.

On all sections of overlay with wearing courses designed to be 1 in or less in thickness, there shall be no pay adjustment for density otherwise noted in Section 403 - Hot Mix Asphalt Pavement. For overlays designed to be 1 in or less in thickness, density shall be obtained by the same rolling train and methods as used on mainline travelway surface courses with a pay adjustment for density, unless otherwise directed by the Department.

There shall be no pay adjustment for density on shoulders unless otherwise noted in Section 403 - Hot Mix Asphalt Pavement. Density for shoulders shall be obtained by the same rolling train and methods as used on mainline travelway, unless otherwise directed by the Department. Efforts to obtain optimum compaction will not be waived by the Department unless it is apparent during construction that local conditions make densification to this point detrimental to the finished pavement surface course.

401.16 Joints The Contractor shall construct wearing course transverse and longitudinal joints in such a manner that minimum tolerances shown in Section 401.11 - Surface Tolerances are met when measured with a straightedge. The paver screed shall maintain a uniform head of HMA during transverse and longitudinal joint construction. The HMA shall be free of segregation and meet temperature requirements outlined in Section 401.04. Transverse joints of the wearing course shall be straight and neatly trimmed. The Contractor may form a vertical face exposing the full depth of the course by inserting a header, by breaking the bond with the underlying course, or by cutting back with hand tools. The Contractor shall apply a coating of emulsified asphalt immediately before paving all joints to the vertical face and 3 in of the adjacent portion of any pavement being overlaid except those formed by pavers operating in echelon. The Contractor shall use an approved spray apparatus designed for covering a narrow surface. The Department may approve application by a brush for small surfaces, or in the event of a malfunction of the spray apparatus, but for a period of not more than one working day.

Where pavement under this contract joins an existing pavement, or when the Department directs, the Contractor shall cut the existing pavement along a smooth line, producing a neat, even, vertical joint. The Department will not permit broken or raveled edges. The cost of all work necessary for the preparation of joints is incidental to related contract pay items. Longitudinal joints shall be generally straight to the line of travel and constructed in a manner that best ensure joint integrity. Methods or activities that prove detrimental to the construction of straight, sound longitudinal joints will be discontinued.

The Contractor may utilize an approved notched wedge joint device on all HMA layers 1 ½ inches in depth or greater. A notched wedge joint shall be constructed as shown in Figure 1 using a device that is attached to the paver screed and is capable of independently adjusting the top and bottom vertical notches.

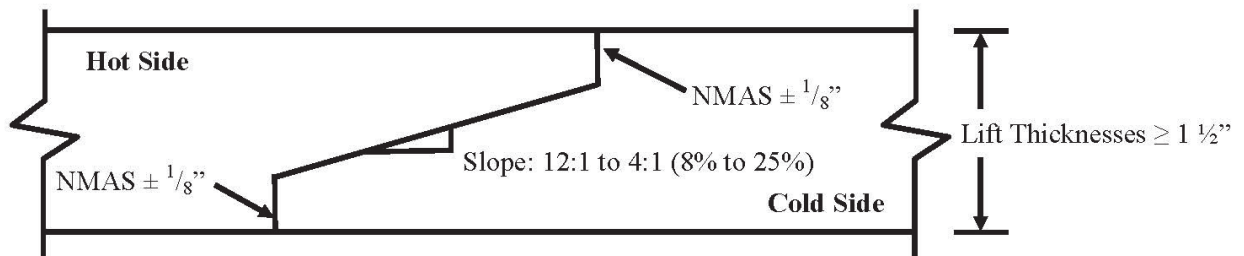

FIGURE 1: Notched Wedge Joint

Notes

1. An emulsified tack coat shall be applied to the vertical edges and the wedge surface so that the total rate is 0.05 G/SY plus the normal specified rate prior to placing the adjacent layer. The Contractor may elect to apply the emulsified tack coat in one or multiple passes.
2. Dimensions shown are compacted depths (after rolling is complete).

The Department reserves the right to have centerline cores cut by the Contractor's QC personnel for informational purposes to monitor the density along the joint. Informational cores at the centerline joint will be taken centered over the tapered part of the wedge joint.

Any notched wedge joint constructed areas that become cracked or broken shall be trimmed back to the limits affected prior to placing the adjoining lane. Any materials that become unbound or separated from the wedge or tapered joint section, or contaminated by materials determined by the Department as being detrimental to the construction of a sound construction joint, shall be removed by sweeping, compressed air and lance, or by hand tools as required. This work, if necessary, will not be paid for directly, but shall be considered incidental to the related contract items.

The Contractor shall apply a coating of emulsified asphalt on the vertical and tapered surface of the longitudinal centerline joint immediately before paving if the notched wedge joint device is used.

The total rate of application shall be 0.050 G/SY plus the normal specified tack coat rate. The Contractor shall use an approved spray apparatus designed for covering a narrow surface. The Department may approve application by a brush for small surfaces.

401.17 Hot Mix Asphalt Documentation The Contractor and the Department shall agree on the amount of Hot Mix Asphalt Pavement that has been placed each day. All delivery slips shall conform to the requirements of 401.078.

401.18 Prepave Meeting Prior to placing any mix, the Department and the Contractor shall hold a Pre-paving conference to discuss the paving schedule, source of mix, type and amount of equipment to be used, sequence of paving pattern, rate of mix supply, random sampling, project lots and sublots and traffic control. A copy of the density QC random numbers to be used on the project shall be provided to the Resident. The Departments' random numbers for Acceptance testing shall be generated and on file with the Resident and the Project Manager. All personnel of the Department and the Contractor who have significant information relevant to the paving items shall attend, including the responsible onsite paving supervisor for the Contractor. The Resident will prepare minutes of the conference and distribute them to all attendees. Any requests to revise the minutes must be made to the Resident within 7 Days of Receipt. These minutes will constitute the final record of the Pre-paving conference. On the first day of paving and whenever there is a change in the onsite paving foreman or paving inspector, the Department and the Contractor shall hold an informal onsite meeting to review the minutes of the Pre-paving conference, Project Specific QCP, Plans, Typical, Special Provisions and communication process. This meeting shall be held prior to placing any mix and, at minimum, shall occur yearly for multi-year contracts. The onsite paving supervisor, QCT, Superintendent, Resident and/or paving inspector shall attend.

401.19 Contractor Quality Control – Method A, B, C & D

The Contractor shall operate in accordance with the approved Quality Control Plan (QCP) to assure a product meeting the contract requirements. The Contractor shall not begin paving operations until the Department approves the QCP in writing.

401.191 Quality Control The QCP shall meet the requirements of Section 106.6 – Acceptance and this Section. The QCP shall address any items that affect the quality of the Hot Mix Asphalt Pavement, and shall include the following personnel meeting these minimum requirements:

- a. QCP Administrator – The QCP Administrator must be a full-time employee of or a consultant engaged by the Contractor or paving subcontractor. The QCP Administrator shall have full authority to institute any and all actions necessary for the successful operation of the QCP. The QCP Administrator (or their designee in the QCP Administrator's absence) shall be available to communicate with the Department at all times.

- For items accepted under Methods A and B, the QCP Administrator shall be certified as a Quality Assurance Technologist (QAT) by NETTCP.
 - For items accepted under Methods C and D, the QCP Administrator shall be certified by NETTCP as a Quality Assurance Technologist (QAT), Plant Technician, or Paving Inspector.
- b. Process Control Technician(s) (PCT) shall utilize test results and other quality control practices to assure the quality of aggregates and other mix components and control proportioning to meet the JMF(s). The PCT shall inspect all equipment used in mixing to assure it is operating properly and that mixing conforms to the mix design(s) and other Contract requirements, and that delivery slips and plant recordation accurately reflects the mix being produced with all the required information. The QCP shall detail how these duties and responsibilities are to be accomplished and documented, and whether more than one PCT is required. The Plan shall include the criteria to be utilized by the PCT to correct or reject unsatisfactory materials. The PCT shall be certified as a Plant Technician by the NETTCP.
- c. Quality Control Technician(s) (QCT) shall perform and utilize quality control tests at the job site to assure that delivered materials meet the requirements of the JMF(s). The QCT shall inspect all equipment utilized in transporting, laydown, and compacting to assure it is operating properly and that all laydown and compaction conform to the Contract requirements. The QCP shall detail how these duties and responsibilities are to be accomplished and documented, and whether more than one QCT is required. The QCP shall include the criteria utilized by the QCT to correct or reject unsatisfactory materials. The QCT shall be certified as a Paving Inspector by the NETTCP.

The QCP shall detail the coordination of the activities of the Plan Administrator, the PCT and the QCT. The Project Superintendent shall be named in the QCP, and the responsibilities for successful implementation of the QCP shall be outlined.

The QCP shall address any items that affect the quality of the Hot Mix Asphalt Pavement including, but not limited to, the following:

a. General Requirements:

- Job Mix Formulas (JMFs)
- Name of QCP Administrator, and certification number
- Description of corrective action process
- Disposition of defective material
- A procedure to take immediate possession of acceptance samples once released by MaineDOT and deliver said samples to the designated acceptance laboratory.
- Type of release agent to be used on haul units, tools and rollers.
- A note stating that the use of petroleum-based fuel oils, such as diesel or kerosene, or asphalt stripping solvents will not be permitted.

b. Process Control Requirements: Each Hot Mix Asphalt plant shall have a Plant Specific Process Control Plan. At minimum the plan shall include:

- Name of Plant Specific Process Control Technician(s) and certification number(s)
- Hot mix asphalt plant details
- Stockpile Management
- Mixing & transportation
- Silo management and details
- A detailed description of RAP processing, stockpiling and introduction into the plant
- PG Binder management:
 - Tanks and storage (including polymer modified binders if applicable)
 - Binder temperature
 - Sample points
 - Method to ensure mixture contains the specified binder grade
 - Additive introduction details if introduced at the plant
- Testing and inspection plan for control of aggregates and RAP
- Mix Testing and inspection plan

c. Quality Control Requirements – Method A & B:

- Name of Quality Control Technicians(s) and certification number(s)
- Laydown operations
- Longitudinal joint construction including the tacking of all joints.
- Procedures for avoiding paving in inclement weather
- Compaction of shoulders
- Methods to ensure that segregation is minimized
- Procedures to determine the maximum rolling and paving speeds based on best engineering practices and past experience in achieving acceptable pavement smoothness.
- Sequence for paving around drainage structures, under guard rail, around curb, at bridges, intersections, drives and minor approaches to ensure proper compaction, finish, and drainage.

d. Quality Control Requirements – Method C and D:

- Name of QCP Administrator and certification number(s) as specified in Section 401.19.
- Name of Process Control Technicians(s) and certification number(s).
- Name of Quality Control Technicians(s) and certification number(s).
- Anticipated Compaction Temperature Zones for each roller zoneduring placement.
- Mix TMD to be used for density gauge setting for method spec density work
- Procedures for avoiding paving in inclement weather.

The Contractor shall also supply a Laydown Operation Plan that addresses sequence of work, layout of work, longitudinal joint construction, compaction of shoulders, methods to minimize segregation, and procedures to achieve acceptable pavement smoothness.

For each production day, a summary of each day's results, including a daily paving report, summarizing the mixture type, mixture temperature, equipment used, environmental conditions, and the number of roller passes, shall be recorded and signed by the QCT and presented to the Department's representative by 1 PM the following working day.

Unless otherwise noted in Section 403 – Hot Mix Asphalt Pavement, the Contractor shall submit a modified QC Plan every year detailing, how the mix is to be placed, what equipment is to be used, and what HMA plant is to be used for Items covered under the Plan. All mix designs (JMF) shall be approved and verified by MaineDOT prior to use.

The Contractor shall certify the mix and the test results for each item by a Certificate of Compliance.

The Contractor shall have a testing lab at the plant site, equipped with all testing equipment necessary to complete the tests in Table 6. The Contractor shall generate QC sampling random numbers for each approved mix design every year. A copy of the random numbers shall be emailed to the QC.mainedot@maine.gov email address and remain on-file (in print) and be available for inspection at the QC laboratory. The Contractor shall sample, test, and evaluate Hot Mix Asphalt Pavement in accordance with the minimum frequencies per each approved mix design.

TABLE 6: MINIMUM QUALITY CONTROL FREQUENCIES

Test or Action	Frequency	Test Method
Temperature of mix	6 per day at street and plant	-
Temperature of mat	4 per day	-
%TMD (In-Place Density - Surface)	1 per 125 ton	AASHTO T 355 or AASHTO T 343
%TMD (In-Place Density - Base)	1 per 250 ton	AASHTO T 355 or AASHTO T 343
Fines / Effective Binder	1 per 500 ton	AASHTO T 312*
Gradation	1 per 500 ton	AASHTO T 30
PGAB Content	1 per 500 ton	AASHTO T 164 or AASHTO T 308
Voids at N_{design}	1 per 500 ton	AASHTO T 312*
VMA at N_{design}	1 per 500 ton	AASHTO T 312*
Rice Specific Gravity	1 per 500 ton	AASHTO T 209
Percent Fractured Particles	1 per 5,000 ton	AASHTO T 335
Flat and Elongated Particles	1 Per 5,000 ton	ASTM D4791
Fine Aggregate Angularity	1 Per 5,000 ton	AASHTO T 304

The Contractor shall monitor plant production on each approved mix design using running average of three control charts as specified in Section 106 - Quality. Control limits shall be as noted in Table 7 below. The UCL and LCL, shall not exceed the allowable gradation control points for the particular type of mixture as outlined in Table 1 of Section 703.09.

TABLE 7: CONTROL LIMITS

Property	UCL and LCL
Percent Passing 4.75 mm and larger sieves	Target +/- 4.0
Percent Passing 2.36 mm sieve	Target +/- 2.5
Percent Passing 0.075 mm sieve	Target +/- 1.0
PGAB Content	Target +/- 0.25
VMA at N_{design}	LCL = LSL + 0.2
Voids at N_{design}	JMF Target +/- 1.2
Theoretical Maximum Specific Gravity	JMF Target +/- 0.020

The Contractor shall submit all QC test and inspection reports and updated control charts to the Resident and QC.mainedot@maine.gov by email. The reports and updated control charts shall be signed by the appropriate technician and be submitted to the Department by 1:00 P.M. on the next working day, except when otherwise noted in the QCP and approved by the Department.

The Contractor shall also retain splits of the previous 5 QC tests, with QC results enclosed for random selection and testing by the Department. Test results of splits that do not meet the Dispute Resolution

Variance Limits in Table 18 shall trigger an investigation by the MaineDOT Independent Assurance Unit and may result in that lab losing NETTCP certification and the ability to request a dispute [Section 401.50 - Process for Dispute Resolution].

The Contractor shall make density test results, including randomly sampled densities, available to the Department onsite. Summaries of each day's results, including a daily paving report summarizing the mixture type, mixture temperature, equipment used, environmental conditions, and the number of roller passes, shall be recorded and signed by the QCT and provided to the QC.mainedot@maine.gov email address and Resident in writing by 1:00 p.m. the next working day. The Contractor shall fill all holes in the pavement resulting from cutting cores by the Contractor or the Department with a properly compacted, acceptable mixture no later than the following working day. Before filling, the Contractor shall carefully clean the holes and apply a coating of emulsified asphalt. The Contractor may only cut additional cores for verification of the densometer, at a rate not to exceed 3 per day or 2 per 1000 ton placed.

If the Contractor's control chart shows the process for a given mix design to be out of control (defined as a single point outside of the control limits on the running average of three chart) on any property listed in Table 7: Control Limits, the Contractor shall notify the Resident of all affected projects in writing of the corrective action by 1:00 PM the next working day. The written description shall detail what action is being taken by the Contractor to bring the property in question back within control limits. Subsequent quality control results are expected to demonstrate an improvement and regression towards the aim. The Department reserves the right to take action, to include cessation of production, in the case of repeated results outside the Table 7 control chart control limits.

On a daily basis, or whenever equipment type or sequence is modified, the Contractor shall perform density testing across the mat being placed, prior to being compacted by equipment at 12 in intervals. If the density values vary by more than 2.0% from the mean, the Contractor shall make adjustments to the screed until the inconsistencies are remedied. Failure to replace or repair defective placement equipment may result in a letter of suspension of work and notification of a quality control violation resulting in possible monetary penalties as governed by Section 106 – Quality.

The Contractor shall cease paving operations whenever one of the following occurs:

- a. The quality level for density using all quality control tests for the current Lot is less than 60 PWL.
- b. The Coarse Aggregate Angularity or Fine Aggregate Angularity value falls below the requirements of Section 703.07, Table 3: Aggregate Consensus Properties Criteria for the design traffic level.
- c. The Flat and Elongated Particles value exceeds 10% by ASTM D4791.
- d. There is any visible damage to the aggregate due to over-densification other than on variable depth shim courses.
- e. The Contractor fails to follow the approved QCP.

The Contractor shall notify the Resident in writing as to the reason for shutdown, as well as the corrective action, by the end of the workday. Failure to do so will be treated as a second incident under 106.4.6 QCP Non-compliance. The Department will only allow the continuation of paving operations when it is satisfied the corrective action will result in an improvement in results. The Department may require the submittal of a passing verification sample to allow further production. The Department

retains the exclusive right, with the exception of the first day's production of a new JMF, to determine whether the resumption of production involves a significant change to the production process. If the Department so determines, then the current lot will be terminated, a pay factor established, and a new lot will begin.

The Contractor may utilize innovative equipment or techniques not addressed by the Contract documents to produce or monitor the production of the mix, subject to approval by the Department.

401.192 Quality Control and Acceptance for Item 403.209 Hot Mix Asphalt, 9.5 mm Nominal Maximum Size, (sidewalks, drives, islands & incidentals) and visual acceptance items Item 403.209 will be accepted under method D acceptance unless otherwise noted in the 403 special provision. A QCP, certified QC personnel, or Prepave Meeting shall not be required for Item 403.209 - Hot Mix Asphalt, 9.5 mm Nominal Maximum Size (sidewalks, drives, islands & incidentals) when accepted under either visual acceptance or under Method D acceptance unless otherwise specified in the 403 SP. An approved JMF shall be provided to the Resident prior to placement.

401.20 Acceptance Method A & C These methods utilize Quality Level Analysis and pay factor specifications. For Hot Mix Asphalt Pavement designated for acceptance under Quality Assurance provisions, the Department will sample once per subplot on a statistically random basis, test, and evaluate in accordance with the Acceptance Properties as outlined in Table 8:

TABLE 8: ACCEPTANCE PROPERTIES – METHOD A & C

Properties	Point of Sampling	Test Method
Gradation	Paver Hopper	AASHTO T 30
PGAB Content	Paver Hopper	AASHTO T 308
% TMD (In-Place Density)	Mat behind all Rollers	AASHTO T 269
Voids at N_{design}	Paver Hopper	AASHTO T 312
VMA at N_{design}	Paver Hopper	AASHTO T 312
Fines to Effective Binder	Paver Hopper	AASHTO T 312
VFB	Paver Hopper	AASHTO T 312

The Department will obtain samples of Hot Mix Asphalt Pavement in conformance with AASHTO R 97, Sampling Asphalt Mixtures, and the MaineDOT Policies and Procedures for HMA Sampling and Testing. The Contractor shall transport the samples in containers provided by the Department to the designated MaineDOT Laboratory within 48 hours except when otherwise noted in the project specific QCP or as directed by the Resident. Failure to deliver an acceptance sample to the designated acceptance laboratory will be considered the second incident under 106.4.6–QCP Non-Compliance.

Target values shall be as specified in the JMF. The Department will withhold reporting of the test results for the Acceptance sample until 7:00 AM, on the second working day of receipt of the sample, or after receipt of the Contractors results of the Acceptance sample split. Upon conclusion of each lot being evaluated under quality level analysis, where there is a minimum of four sublots, results shall be examined for statistical outliers, as stated in Section 106.7.2 - Statistical Outliers.

Lot sizes and subplot sizes shall be determined as outlined in Table 9.

TABLE 9: LOT AND SUBLOT SIZES – METHOD A & C

Lot Size*	Entire production per item per contract per year up to 6000 ton
Maximum Sublot Size – Mix	750 ton
Maximum Sublot Size – Density	Surface Layers – 250 ton Base / Intermediate Layers – 500 ton
Minimum Number of Samples – Mix	Four
Minimum Number of Samples – Density	Five

*General – Lot and Sublot size may be adjusted to accommodate the work scope and schedule, or as otherwise agreed upon at the Prepave Meeting

If there is less than one-half of a subplot remaining at the end of production for the year, then it shall be combined with the previous subplot. If there is more than one-half subplot remaining at the end of production for the year, then it shall constitute the last subplot and shall be represented by test results. If it becomes apparent partway through a Lot that, due to an underrun, there will be insufficient mix quantity to obtain the minimum number of sublots needed, the Resident may adjust the size of the remaining sublots and select new sample locations based on the estimated quantity of material remaining in the Lot. Unanticipated over-runs of up to 1500 ton shall be rolled into the last lot. Cases where the lot is terminated prior to reaching completion shall be handled in accordance with [Section 106.7.3 Early Termination of Lots](#). In cases where a density incentive/disincentive provision apply, additional cores shall be taken to attain a minimum of three for the Lot.

Isolated Areas During the course of inspection, should it appear that there is an isolated area that is not representative of the lot based on a lack of observed compactive effort, excessive segregation, a change in process or any other questionable practice, that area may be isolated and tested separately.

An area so isolated that has a calculated pay factor below 0.80 for Method A, based on three random tests shall be removed and replaced at the expense of the Contractor for the full lane width and a length not to be less than 150 ft.

TABLE 10: ACCEPTANCE LIMITS – METHOD A & C

Property	USL and LSL	
	Method A	Method C
Percent Passing 4.75 mm and larger sieves	Target +/- 7%	Target +/- 7%
Percent Passing 2.36 mm to 1.18 mm sieves	Target +/- 4%	Target +/- 5%
Percent Passing 0.60 mm sieve	Target +/- 3%	Target +/- 4%
Percent Passing 0.30 mm to 0.075 mm sieve	Target +/- 2%	Target +/- 2%
PGAB Content	Target +/- 0.4%	Target +/- 0.4%
Voids at N_{design}	4.0% +/- 1.5%	N/A
Fines to Effective Binder	0.9 +/- 0.3	N/A
VMA at N_{design}	LSL from Table 1	N/A
VFB	Table 1 plus a 4% production tolerance for USL	N/A
% TMD (In-place Density)	94.5% +/- 2.5%	94.5% +/- 2.5%

Cease Production The Contractor shall cease paving operations whenever one of the following occurs on a lot in progress:

TABLE 11: CEASE PRODUCTION – METHOD A & C

Property	Percent Within Limits (PWL)	
	Method A	Method C
Percent Passing NMASS sieve*	<60 PWL	<60 PWL
Percent Passing 2.36 mm sieve*		
Percent Passing 0.30 mm sieve*		
Percent Passing 0.075 mm sieve*		
PGAB Content		
Voids at N_{design}	N/A	
Fines to Effective Binder*		
VMA at N_{design}		
VFB	<60 PWL	
% TMD (In-place Density)		

*Paving operations shall not be required to cease if the mean test value is equal to the LSL or USL and $s = 0$.

In cases where the Contractor is to cease paving operations based upon an Acceptance result or payfactor, the Contractor will submit a corrective action plan to the Department. The Department will only allow the continuation of paving operations when it is satisfied the corrective action will result in an improvement in results. The Department may require the submittal of a passing verification sample to allow further production.

401.201 Pay Adjustment - Method A & C The Department will use the following criteria for pay adjustment at the completion of the Lot using the pay adjustment factors under Section 106.7 - Quality Level Analysis.

Density Upon conclusion of each lot, density results shall be examined for statistical outliers as stated in Section 106.7.2. If the pay factor for Density falls below 0.80, all of the cores will be randomly re-cut by Sublot. A new pay factor will be calculated that combines all initial and retest results. If the resulting pay factor is below 0.80, the entire Lot shall be removed and replaced with material meeting the specifications at no additional cost to the Department, except that the Department may, when it appears that there is a distinct pattern of defective material, isolate any defective material by investigating each mix sample subplot and require removal of defective mix sample sublots only, leaving any acceptable material in place if it is found to be free of defective material. Pay factors equal to or greater than the reject level will be paid accordingly.

Mix Properties The Department will determine a pay factor (PF) using the applicable Acceptance Limits. If all three pay factors for PGAB Content, VMA at N_{design} , and Voids at N_{design} fall below 0.80 for Method A, then the composite pay factor for PGAB Content, VMA at N_{design} , and Voids at N_{design} shall be 0.50.

The following variables will be used for pay adjustment:

PA = Pay Adjustment
 Q = Quantity represented by PF in ton
 P = Contract price per ton
 PF = Pay Factor

The Department will determine a pay adjustment using Table 12: Pay Adjustment Calculations as follows:

TABLE 12: PAY ADJUSTMENT CALCULATIONS – METHOD A & C

Acceptance Method	Mix Properties / Gradation	Density
Method A	$PA = (\text{Voids @ } N_d \text{ PF} - 1.0)(Q)(P)x0.20 + (\text{VMA @ } N_d - 1.0)(Q)(P)x0.20 + (\text{PGAB Content PF} - 1.0)(Q)(P)x0.10$	$PA = (\text{density PF} - 1.0)(Q)(P)x0.50$
Method C	$PA = (\% \text{ Passing Nom. Max PF} - 1.0)(Q)(P)x0.05 + (\% \text{ passing 2.36 mm PF} - 1.0)(Q)(P)x0.05 + (\% \text{ passing 0.30 mm PF} - 1.0)(Q)(P)x0.05 + (\% \text{ passing 0.075 mm PF} - 1.0)(Q)(P)x0.10 + (\text{PGAB Content PF} - 1.0)(Q)(P)x0.25$	$PA = (\text{density PF} - 1.0)(Q)(P)x0.50$

In addition, for 9.5 mm NMA mixtures the following pay adjustment shall also apply:

The average percent passing for the 0.075 mm sieve shall be evaluated for each Lot. If the average is greater than 6.5%, a pay adjustment according to Table 13 below shall apply in addition to the other pay adjustments for the given method of testing.

TABLE 13: 0.075 MM SIEVE PAY ADJUSTMENT

Average Percent Passing 0.075 mm Sieve	Pay Adjustment
6.6% - 7.0%	-5%
> 7.0%	-10%

The Department shall notify the Contractor whenever the average of at least three samples in a given Lot is greater than 6.5%.

401.21 Acceptance Method B & D Unless otherwise stated in the 403 special provision, the Lot shall be the entire mix quantity per item per contract per year. The Department will sample once per subplot per pay item on a statistically random basis, test, and evaluate in accordance with the Acceptance Properties in Table 14. The Department will obtain samples of Hot Mix Asphalt Pavement in conformance with AASHTO R 97, Sampling Asphalt Mixtures, and the MaineDOT Policies and Procedures for HMA Sampling and Testing. The Contractor shall transport the samples in containers provided by the Department to the designated MaineDOT Laboratory within 48 hours except when otherwise noted in the project specific QCP or as directed by the Resident. Failure to deliver an acceptance sample to the designated acceptance laboratory will be considered the second incident under 106.4.6–QCP Non-Compliance. Target values shall be as specified in the JMF. The Department will withhold reporting of the test results for the Acceptance sample until 7:00 AM, on the second working day of receipt of the sample, or after receipt of the Contractors results of the Acceptance sample split.

TABLE 14: ACCEPTANCE PROPERTIES – METHOD B & D

Properties	Point of Sampling		Test Method
	Method B	Method D	
Gradation	Paver Hopper	Paver Hopper or Truck	AASHTO T 30
PGAB Content	Paver Hopper	Paver Hopper or Truck	AASHTO T 308
% TMD (In-Place Density)	Mat behind all Rollers	Mat behind all Rollers	AASHTO T 269
Voids at N_{design}	Paver Hopper	N/A	AASHTO T 312
VMA at N_{design}	Paver Hopper	N/A	AASHTO T 312
Fines to Effective Binder	Paver Hopper	N/A	AASHTO T 312
VFB	Paver Hopper	N/A	AASHTO T 312

TABLE 15: LOT AND SUBLOT SIZES – METHOD B & D

Lot Size*	Entire mix quantity per item per contract per year
Maximum Sublot Size – Mix	250 ton (Max 4 Sublots)
Sublot Size – Density	125 ton (Max 5 Sublots)

*General – Lot and Sublot size may be adjusted to accommodate the work scope and schedule, or as otherwise agreed upon at the Prepave Meeting

If there is less than one-half of a subplot remaining at the end of production for the year, then it shall be combined with the previous subplot. If there is more than one-half subplot remaining at the end of production for the year, then it shall constitute the last subplot.

TABLE 16: ACCEPTANCE LIMITS – METHOD B & D

Property	USL and LSL	
	Method B	Method D
Percent Passing 4.75 mm and larger	Target +/- 7%	Target +/- 7%
Percent Passing 2.36 mm sieve	Target +/- 5%	Target +/- 7%
Percent Passing 1.18 mm sieve	Target +/- 5%	Target +/- 5%
Percent Passing 0.60 mm sieve	Target +/- 4%	Target +/- 4%
Percent Passing 0.30 mm sieve	Target +/- 3%	Target +/- 3%
Percent Passing 0.075 mm sieve	Target +/- 3%	Target +/- 3%
PGAB Content	Target +/- 0.5%	Target +/- 0.5%
Voids at N_{design}	4.0% +/- 2.0%	N/A
Fines to Effective Binder	0.9 +/- 0.3	N/A
VMA at N_{design}	LSL from Table 1	N/A
VFB	Table 1 plus a 4% production tolerance for USL	N/A
% TMD (In-place Density)	94.5% +/- 2.5%	LSL of 92.0%

The Contractor shall cease paving operations whenever two consecutive Method B or D tests fall outside specification limits on the same property. The Contractor will submit a corrective action plan to the Department. The Department will only allow the continuation of paving operations when it is satisfied the corrective action will result in an improvement in results. The Department may require the submittal of a passing verification sample to allow further production.

401.211 Pay Adjustment - Method B & D For items accepted under Method B or D, if the mix is within the tolerances listed in Table 16, the Department will pay the contract unit price. Otherwise, pay adjustments as shown in Table 17 shall be applied to the quantity of mix represented by the test. The Contractor shall cut one 6 in core per subplot unless otherwise noted in Section 403 - Hot Mix Asphalt Pavement. If the density result is not within the specified limits the disincentive shall apply. If the subplot density is less than 88.5 percent or greater than 99.0 percent of the subplot TMD, two additional cores shall be cut at random locations determined by the Department. If either of the additional cores has a density less than 88.5 percent or greater than 99.0 percent of the subplot TMD, the subplot shall be removed and replaced at no cost to the Department; otherwise, the average of the three cores will be used to determine the subplot pay adjustment.

TABLE 17: PAY ADJUSTMENTS – METHOD B & D

Property	Method B		Method D	
Percent Passing 2.36 mm sieve	N/A		-2.0%	
Percent Passing 0.30 mm sieve	N/A		-1.0%	
Percent Passing 0.075 mm sieve	-2.0%		-2.0%	
PGAB Content	-5.0%		-5.0%	
Voids at N_{design}	-3.0%		N/A	
% TMD (In-place Density)	91.5% - 91.9% or 97.1% - 97.5%	-5.0%	91.5% - 91.9%	-5.0%
	90.5% - 91.4% or 97.6% - 98.5%	-10.0%	90.5% - 91.4%	-10.0%
	89.5% - 90.4% or 98.6% - 99.0%	-20.0%	89.5% - 90.4%	-20.0%
	88.5% - 89.4%	-30.0%	88.5% - 89.4%	-30.0%
	<88.5% or >99.0%	Reject	<88.5% or >99.0%	Reject

401.30 Method of Measurement The Department will measure Hot Mix Asphalt Pavement by the ton in accordance with Section 108.1 - Measurement of Quantities for Payment.

401.40 Basis of Payment The Department will pay for the work, in place and accepted, in accordance with the applicable sections of this Section, for each type of HMA specified.

The Department will pay for the work specified in Section 401.12, for the HMA used, except that cleaning objectionable material from the pavement and furnishing and applying bituminous material to joints and contact surfaces is incidental. Payment for this work under the appropriate pay items shall be full compensation for all labor, equipment, materials, and incidentals necessary to meet all related contract requirements, including design of the JMF, implementation of the QCP, obtaining core samples, transporting cores and samples, filling core holes, applying emulsified asphalt to joints, and providing testing facilities and equipment. The Department will make a pay adjustment for quality as specified in Section 401.20 Acceptance Method A & B or 401.21 Acceptance Method C & D.

401.50 Process for Dispute Resolution At the time of Hot-Mix Asphalt sampling, the Department will obtain a split sample of each Acceptance test random sample for possible dispute resolution testing. The Contractor shall also obtain a split sample of the HMA at this same time. If the Contractor wishes to retain the option of requesting dispute testing of the initial Acceptance sample, the Contractor will test their split of the Acceptance sample in accordance with applicable AASHTO procedure and accepted supplemental practice as described in the Department's HMA Sampling and Testing Policies and Procedures manual. The Contractor shall report their results to the Resident, with a copy to Contractor.mainedot@maine.gov by 7:00 AM, on the second working day from time of QA sampling, otherwise dispute resolution will not be initiated. The Department's dispute resolution split sample will be properly labeled and stored for a period of at least two weeks after it has been reported, or until the sample is tested. The properties eligible for dispute and the respective variances are shown in Table 18.

The Contractor may dispute the Department's Acceptance results and request that the dispute resolution split sample be tested by notifying the Department's Resident and QA Engineer in writing within two working days after the results of the Acceptance test are reported. The following shall be provided in the request:

- Acceptance sample reference number
- The specific test result(s) or property(ies) being disputed, and
- The complete, signed report of the Contractor's testing (In a lab certified by the NETTCP and MaineDOT) of their split of the Acceptance sample indicating that the variances in Table 18 for the specific test result(s) or property(ies) were met or exceeded.

TABLE 18: DISPUTE RESOLUTION VARIANCE LIMITS

Property	Method A & B	Method C & D*	Variance Limits
PGAB Content	Yes	Yes	+/- 0.4%
G_{mb}	Yes	No	+/- 0.030
G_{mm}	Yes	Only if referenced to a Core	+/- 0.020
Voids at N_{design}	Only if G_{mb} or G_{mm} is not disputable	No	+/- 0.8%
VMA at N_{design}	Only if G_{mb} or G_{mm} is not disputable	No	+/- 0.8%
Percent Passing 4.75 mm and larger sieves	No	Yes^	+/- 4.0%
Percent Passing 2.36 mm to 0.60 mm sieves	No	Yes^	+/- 3.0%
Percent Passing 0.30 mm to 0.15 mm sieves	No	Yes^	+/- 2.0 %
0.075 mm sieve	Only for 9.5 mm NMAS mixes	Yes	+/- 0.8%

*Disputes will not be allowed on Item 403.209

^Disputes will only be allowed on Sieve Sizes used for pay adjustment calculations

The value of any disputed result or property reported for the initial Acceptance sample shall stand if the value reported for the dispute resolution sample is not closer to the value the Contractor reported for their split sample than to the value reported for the initial Acceptance sample. If the value reported for the dispute resolution falls precisely half-way between the other two values the value reported for the dispute resolution will replace the original acceptance value. Otherwise, the value reported for the dispute resolution sample will replace the value reported for the initial Acceptance sample and will be used to re-calculate any other affected results or properties.

SECTION 402 - PAVEMENT SMOOTHNESS

402.00 Smoothness Projects Projects to have their pavement smoothness analyzed in accordance with this Specification will be so noted in Special Provision 403 - Hot Mix Asphalt Pavement.

402.01 Pavement Smoothness The final pavement surface shall be evaluated for smoothness using a Class I or Class II profiler as defined by ASTM E950 (94). Smoothness measurements will be expressed in terms of the International Roughness Index (IRI) as defined by the World Bank, in units of inches/mile.

402.02 Lot Size Lot size for smoothness will be 3000 lane-feet. A subplot will consist of 50 lane-feet. Partial lots will be included in the previous lot if less than one-half the size of a normal lot. If equal to or greater than one-half the normal lot size, it will be tested as a separate lot.

402.03 Acceptance Testing The Department will conduct Acceptance testing following completion of the surface course. Sections to be excluded from testing include the following:

- Bridge decks and joints (no smoothness measurements will be taken within 100 ft of bridge joints)
- Acceleration and deceleration lanes
- Shoulders and ramps
- Side streets and roads
- Within 100 ft of transverse joints at the beginning and end of the project
- Within 100 ft of railroad crossings
- Urban areas with speed limits of 30 mph or lower

Each lot shall have 2 measurements made in each wheel path. The average of the 4 measurements will determine the smoothness for that lot. The smoothness measurements will be statistically evaluated for pay factors as described in Subsection 106.7 - Quality Level Analysis, using the specification limits shown below.

TABLE 1: ACCEPTANCE LIMITS

Level	USL
I	55 in/mile
II	65 in/mile
III	75 in/mile

Computation of Smoothness Pay Adjustment:

PA = (PF-1.0)(Q)(P) where:

Q = Quantity of surface course in the Lot (excluding shoulders, side streets, bridge decks, ramps, acceleration and deceleration lanes)

PF = smoothness pay factor for the Lot

P = Contract unit price for surface pavement

PA = pay adjustment

402.04 Unacceptable Work In the event that any Lot is found to have a pay factor less than 0.80, the Contractor shall take whatever remedial action is required to correct the pavement surface in that Lot at no additional expense to the Department. Such remedial action may include but is not limited to removal and replacement of the unacceptable pavement. In the event remedial action is necessary, the Contractor shall submit a written plan to the Resident outlining the scope of the remedial work. The Resident must approve this plan before the remedial work can begin. Following remedial work, the Lot shall be retested, and will be subject to the specification limits listed above. The resulting pay factor, if within the acceptable range, will be used in the final pay adjustment. The Contractor shall pay the cost of retesting the pavement following corrective action.

Localized surface tolerance defects will be subject to the provisions outlined in Section 401.11 Surface Tolerances.

Payment will be made under:

Pay Item

402.10 Incentive/Disincentive - Pavement Smoothness

Pay Unit

Lump Sum

SECTION 403 - HOT MIX ASPHALT PAVEMENT

403.01 Description This work shall consist of constructing one or more courses of Hot Mix Asphalt pavement on an approved base in accordance with these specifications, and in reasonably close conformity with the lines, grades, thickness and typical cross sections shown on the plans or established. The HMA pavement shall be composed of a mixture of aggregate, filler if required, and asphalt material.

403.02 General The materials and their use shall conform to the requirements of Section 401 - Hot Mix Asphalt Pavement.

403.03 Construction The construction requirements shall be as specified in Section 401 - Hot Mix Asphalt Pavement.

403.04 Method of Measurement Hot mix asphalt pavement will be measured as specified in Section 401.21- Method of Measurement.

403.05 Basis of Payment The accepted quantities of hot mix asphalt pavement will be paid for at the contract unit price per ton for the mixtures, including hot mix asphalt material complete in place. Method A, Method B, Method C and Method D shall be used for acceptance as specified in Section 401 - Hot Mix Asphalt Pavements. (See Complementary Notes, Section 403 - Hot Mix Asphalt Pavement, for Method location).

Payment will be made under:

<u>Pay Item</u>	<u>Pay Unit</u>
403.102 Hot Mix Asphalt Pavement for Special Areas	Ton
403.206 Hot Mix Asphalt, 25 mm Nominal Maximum Size	Ton
403.207 Hot Mix Asphalt, 19.0 mm Nominal Maximum Size	Ton
403.2071 Hot Mix Asphalt, 19.0 mm Nominal Maximum Size (Polymer Modified)	Ton
403.2072 Asphalt Rich Hot Mix Asphalt, 19.0 mm Nominal Maximum Size (Asphalt Rich Base and Intermediate course)	Ton
403.208 Hot Mix Asphalt, 12.5 mm Nominal Maximum Size	Ton
403.2081 Hot Mix Asphalt - 12.5 mm Nominal Maximum Size (Polymer Modified)	Ton
403.209 Hot Mix Asphalt, 9.5 mm Nominal Maximum Size (Sidewalks, Drives, Islands & Incidentals)	Ton
403.210 Hot Mix Asphalt, 9.5 mm Nominal Maximum Size	Ton
403.2101 Hot Mix Asphalt, 9.5 mm Nominal Maximum Size (Polymer Modified)	Ton
403.2104 Hot Mix Asphalt, 9.5 mm Nominal Maximum Size (Thin Lift Surface Treatment)	Ton
403.211 Hot Mix Asphalt, 9.5 mm Nominal Maximum Size (Shimming)	Ton
403.2111 Hot Mix Asphalt, 9.5 mm Nominal Maximum Size (Shimming, Polymer Modified)	Ton
403.212 Hot Mix Asphalt, 4.75 mm Nominal Maximum Size	Ton
403.213 Hot Mix Asphalt, 12.5 mm Nominal Maximum Size (Base and Intermediate Base course)	Ton
403.2131 Hot Mix Asphalt, 12.5 mm Nominal Maximum Size (Base and Intermediate Base course, Polymer Modified)	Ton
403.2132 Asphalt Rich Hot Mix Asphalt, 12.5 mm Nominal Maximum Size (Base and Intermediate Base course)	Ton
403.214 Hot Mix Asphalt, 4.75 mm Nominal Maximum Size (5/8" Surface Treatment)	Ton

SPECIAL PROVISION
SECTION 401
HOT MIX ASPHALT PAVEMENT

401 HOT MIX ASPHALT LONGITUDINAL JOINT DENSITY

401.30 Description The Department will measure the pavement density of longitudinal joints constructed between adjoining travel lanes; turn lanes, truck (climbing) lanes, passing lanes, and any other areas considered mainline travelway for conventional density testing will be considered travel lanes for longitudinal joint density testing as noted in Section 403 – Hot Mix Asphalt Pavement. Core samples shall be tested according to AASHTO T-166. The Contractor shall cut 6-inch diameter cores at no additional cost to the Department by the end of the working day following paving. Pre-testing of the acceptance cores will not be allowed. If the Contractor and the Department mutually determine that a core is damaged, the Contractor shall cut new core(s) at the same offset and within 3 ft of the initial sample. The Contractor and the Department will mutually determine if underlying material is adhered to the core and if so will mark the core at the point where sawing is needed. The Department will place the cores in a secure container and the Contractor shall transport the cores to the designated MaineDOT lab. The cores will be saw cut by the Department to remove underlying layers. No recuts are allowed at a test location after the core has been tested.

For vertical longitudinal joints, cores shall be taken directly centered over the construction joint. For notch-wedge longitudinal joints, the cores shall be cut directly over the center of the tapered portion of the wedge.

As part of the project specific QCP, the Contractor shall include details as to methods of construction, rolling and compaction efforts, and action plan to adjust methods or equipment should the Quality level fall below 50 percent within limits. The Contractor shall be required to measure the joint density at randomly selected locations with a minimum frequency of one measurement per 750 linear feet. The Contractor shall have the option to cut calibration/verification cores at a rate not to exceed 1 per day.

If the Quality level for density falls below 50 percent within limits, the Contractor shall cease placement operations and submit a corrective action letter to the Department before proceeding with the Lot or before starting a new Lot. The Department will respond and either accept or reject the Contractor's proposed corrective action. If the Department accepts the corrective action, three stratified verification cores will be taken from the first 1500 foot section of longitudinal joint constructed for the purpose of evaluating the corrective action. These cores will be in addition to any Acceptance cores that may be designated in this area. The results from these cores shall be combined with the cores from the Lot in progress. Should the combined Quality level for density show an improvement, the Department will accept the corrective action and normal Acceptance sampling frequency shall resume. If an improvement has not been made to the combined Quality level for density, the Contractor shall cease production and submit an additional corrective action letter for consideration.

401.31 Acceptance This method utilizes Quality Level Analysis and pay factor specifications as described in Section 106. For Hot Mix Asphalt Pavement designated for acceptance under Quality Assurance provisions, the Department will sample once per subplot on a statistically random basis, test, and evaluate in accordance with the following Acceptance Properties:

The Lot size will be the total length of eligible longitudinal joint(s) for the given HMA layer for the project, or equal Lots of a size agreed upon at the Pre-paving conference. The maximum subplot size shall be 2000 linear feet of longitudinal joint for density and the minimum number of sublots for any Lot shall be five. The Lot will be divided up into sublots of equal length. There shall be a separate Lot for each lift of HMA pavement and Lots shall not be comprised of results from more than one HMA layer. For tracking purposes, the method of testing shall be “C”.

The Department will determine a pay factor using acceptance limits from Table 1.

TABLE 1: LONGITUDNAL JOINT DENSITY ACCEPTANCE LIMITS

PROPERTY	LSL
% TMD (In-Place Density)*	91.0%

* The Theoretical Maximum Density will be determined from the average of the G_{mm} values used to determine the percent compaction of the nearest acceptance cores on either side of the Longitudinal Joint Core from each adjacent mat.

The Department will calculate the Pay Adjustment for Longitudinal Joint Density as follows:

$$PA = (\text{joint density PF} - 1.0)(Q)(P) \times 0.40$$

Where

- PA = Pay Adjustment
- Q = Quantity of traveled way pavement represented by PF in tons
- P = Contract price per ton
- PF = Pay Factor

If the joint density Pay Factor is less than 0.88, the Pay Adjustment shall be:

$$PA = (-0.05)(Q)(P)$$

SPECIAL PROVISION
SECTION 401
SECTION 401 - HOT MIX ASPHALT PAVEMENT
(HMA Hamburg Wheel Tracker Specification)

401.03 Composition of Mixtures The Contractor shall compose the Hot Mix Asphalt Pavement with aggregate, Performance Graded Asphalt Binder (PGAB), and mineral filler if required. HMA shall be designed and tested according to AASHTO R35 and the volumetric criteria in Table 1. The Contractor shall size, uniformly grade, and combine the aggregate fractions in proportions that provide a mixture meeting the grading requirements of the Job Mix Formula (JMF). Unless otherwise noted in Special Provision 403 - Hot Mix Asphalt Pavement, the design, verification, Quality Control, and Acceptance tests for this mix will be performed at 65 gyrations.

TABLE 1: VOLUMETRIC DESIGN CRITERIA

Design ESAL's (Millions)	Required Density (Percent of G _{mm})			Voids in the Mineral Aggregate (VMA)(Minimum Percent)					Voids Filled with Binder (VFB) (Minimum %)	Fines/Eff. Binder Ratio
				Nominal Maximum Aggregate Size (mm)						
	N _{initial}	N _{design}	N _{max}	25	19	12.5	9.5	4.75		
<3	≤90.5	96.0	≤98.0	13.0	14.0	15.0	16.0	16.0	65-80*	0.6-1.2
3 to <10	≤89.0									
≥ 10	≤89.0									

*For 9.5 mm nominal maximum aggregate size mixtures, the maximum VFB is 82.

*For 4.75 mm nominal maximum aggregate size mixtures, the maximum VFB is 84.

The Contractor shall submit for Department approval a JMF to the Pavement Materials Engineer for each mixture to be supplied including the PG binder grade/supplier and the intended test temperature for the HWT approval. The JMF will be approved by the Department in accordance with the MaineDOT HMA Policies and Procedures for HMA Sampling and Testing Manual. If the Contractor is submitting a new JMF, the Contractor shall identify and make available the stockpiles of all proposed aggregates at the plant site at the time of JMF submittal. There must be a minimum of 150 ton for coarse aggregate stockpiles and 75 ton for fine aggregate stockpiles before the JMF may be submitted. The Contractor shall provide aggregate samples to the Department unless otherwise required. The Contractor shall also make available to the Department the PG Binder proposed for use in the mix in sufficient quantity to test the properties of the asphalt and to produce samples for testing of the mixture. If the Contractor is submitting a new JMF the first day's production shall be monitored, and approval may be withdrawn if the mixture exhibits undesirable characteristics such as checking, shoving or displacement. The Contractor shall be allowed to submit aim changes for a JMF as outlined in the MaineDOT HMA Policies and Procedures for HMA Sampling and Testing Manual: Mix Design Approval Section.

The Contractor shall submit a new JMF for approval each time a change in material source or materials properties is proposed. The same approval process shall be followed. The cold feed percentage of any aggregate may be adjusted up to 10 percentage points from the amount listed on the JMF, however no aggregate listed on the JMF shall be eliminated. The cold feed percentage for RAP may be reduced up to 10 percentage points from the amount listed on the JMF and shall not exceed the percentage of RAP approved in the JMF or for the specific application under any circumstances.

If submitting a new JMF, the Contractor shall provide the Department with eight boxes of plant produced HMA before the start of paving. The Contractor shall test its split of the sample and determine if the results meet the requirements of the Department’s written policy for mix design verification (See MaineDOT Policies and Procedures for HMA Sampling and Testing). If the results are found to be acceptable, the Contractor will forward their results to the Department’s Lab, which will test the Department’s split of the sample. The results of the two split samples will be compared and shared between the Department and the Contractor. If the HMA meets the requirements for mix design verification, the mixture will be tested for rutting and moisture sensitivity in the Hamburg Wheel Tracker according to AASHTO T324, “Hamburg Wheel-Track Testing of Hot Mix Asphalt (HMA).” The Department will not test the mixture for HWT until the HMA meets the mix design verification requirements.

The sample will be required to meet the applicable requirements of Table 1A below for approval and will be dependent on the test temperature submitted by the Contractor. The minimum PG Binder grade required shall be as specified by the 403 Special Provision. The Contractor may submit a design with a binder grade exceeding the minimum specified to meet the HWT requirements of the 403. If the sample meets the requirements of Table 1A, an approved JMF listing the approved PG Binder Grade to meet the HWT requirements will be forwarded to the Contractor and paving may commence. The Department will have five business days from receipt of the sample at the Central Laboratory to process, test, and report the Hamburg Wheel Tracker sample. The first day’s production shall be monitored, and the approval may be withdrawn if the mixture exhibits undesirable characteristics such as checking, shoving or displacement.

TABLE 1A: HAMBURG WHEEL TRACKER REQUIREMENTS

Specified PG Binder Grade	Test Temperature (°C)	Maximum Rut Depth (mm)	Minimum Number of Passes	Minimum Allowable SIP*
PG 64-28	45	12.5	20,000	15,000
PG 64E-28	48	12.5	20,000	15,000
PG 70E-28 (or greater)	50	12.5	20,000	15,000

* As calculated by the most recently published version of the MaineDOT HWT worksheet, which is available online at <https://www.maine.gov/dot/doing-business/hma-resources>

Should the Contractor choose to change their PG Binder source and/or modify the PG Binder grade after initial approval, the Department will take an additional verification sample and test the HMA to verify compliance with the Hamburg Wheel Tracker Requirements. If this sample fails to meet the criteria in Table 1A, the Contractor will be required cease production and submit a corrective action letter to the Department. HWT approval of the JMF will be suspended until the Department can verify that the submitted sample meets the requirements of Table 1A. Failure to notify the Department of a change in supplier will be treated as a second incident under 106.4.6 QCP Non-compliance.

401.19 Contractor Quality Control - Method A, B, C & D The following language has been added to Section 401.19:

The project specific QCP shall address the PG Binder source and grade, sampling, transport, and testing of Hamburg Wheel Tracker QC samples and what potential steps will be taken if QC samples do not meet the requirements in Table 1A. The project-specific QCP shall also contain a sample Hamburg Wheel Tracker test report for approval. The Contractor shall sample and test HMA Pavement in the Hamburg Wheel Tracker according to AASHTO T324 in accordance with the following minimum frequencies:

TABLE 2A: MINIMUM QUALITY CONTROL FREQUENCIES

Test or Action	Frequency	Test Method
Hamburg Wheel Tracker	1 per 6,000 ton and at least once per Acceptance Lot	AASHTO T 324

If the Contractor is submitting a new JMF the Contractor shall sample the HMA on the first day of production and test the sample in the Hamburg Wheel Tracker according to AASHTO T324. This sample will not count towards the minimum quality control frequency specified in Table 2A.

The Contractor shall submit all Hamburg Wheel Tracker test reports in writing, signed by the appropriate technician and present them to the Department within ten working days of initial sampling, except when otherwise noted in the project specific QCP due to local restrictions. The Contractor shall make the raw Hamburg Wheel Tracker data from QC samples available to the Department upon request. If a QC sample fails to meet the criteria in Table 1A, the Contractor will be required to submit a corrective action letter to the Resident, Materials Engineer, Pavement Quality Manager, and Pavement Quality Engineer by the end of the following working day with the proposed changes to bring the mixture back into compliance. The Department will respond and either accept or reject the Contractor’s proposed corrective action by the end of the following working day from when the letter was received.

401.20 & 401.21 Acceptance Method(s) A, B, C & D The following language has been added to Section(s) 401.20 & 401.21

First Day Production HWT Verification Sample for Acceptance The Department will sample the HMA on the first day of production. This sample will be considered a first day of production HWT verification sample and will not count towards the minimum HWT acceptance frequencies specified in Table 3A unless otherwise determined by the Department. This sample may be taken in conjunction with the first mix acceptance sample. The number of boxes required will be as specified in Table 3B.

If the first day of production HWT verification sample fails to meet the criteria in Table 1A or yields two consecutive inconclusive results, the Contractor shall cease paving operations and submit a verification sample to the Department. HWT approval of the JMF will be suspended until the Department can verify that the submitted sample meets the requirements of Table 1 and Table 1A.

A first day production sample will not be required for a previously approved JMF that has met HWT requirements listed in Table 1A if the following criteria have been met:

1. A minimum of one passing HWT Department issued acceptance results within the calendar year (Construction Season) of production.
2. A minimum of three consecutive passing HWT Department issued acceptance results within the past year of production (365 days). These results shall be the three most recent Department issued acceptance samples.
3. No changes in the source of the PG Binder and/or modifications to the PG Binder grade from the initial HWT approval have been made.

As part of the QCP, the Contractor shall provide in writing the request to waive the first day production sample and will include the necessary supporting documentation as specified above.

Acceptance Sampling The Department will sample at the HWT acceptance frequencies specified in Table 3A to verify the compliance with the Hamburg Wheel Tracker Requirements. The number of boxes required will be as specified in Table 3B, with two boxes reserved for retesting of inconclusive results. A mix acceptance sample within an acceptance lot will be selected at random by the Department for HWT acceptance sampling. Depending on daily production rates, the first day of production HWT verification sample and the first acceptance sample may be taken on the same day, but shall not be from the same acceptance sample unless otherwise determined by the Department.

If a HWT acceptance sample fails to meet the criteria in Table 1A and fails to exceed an average of 15,000 cycles, the Contractor shall cease paving operations and submit a verification sample to the Department. HWT approval of the JMF will be suspended until the Department can verify that the submitted sample meets the requirements of Table 1 and Table 1A. A pay factor will be determined using Table 4.

If a HWT acceptance sample fails to meet the criteria in Table 1A, but exceeds an average of 15,000 cycles, the Contractor shall cease paving operations and submit a Corrective Action to the Department. A pay factor for the failing sample will be determined using Table 4.

Inconclusive Results If a HWT acceptance sample indicates an “inconclusive result” the Department will immediately retest the sample using the additional retained 2 boxes. Should the second sample also yield an inconclusive result, the Contractor shall cease paving operations and submit a verification sample to the Department. HWT approval of the JMF will be suspended until the Department can verify that the submitted sample meets the requirements of Table 1 and Table 1A.

Informational Sampling At the Resident’s discretion, the Department may take additional informational samples and test the HMA to verify compliance with the Hamburg Wheel Tracker Requirements. If an informational sample fails to meet the criteria in Table 1 or Table 1A, the Contractor will be required to submit a corrective action letter to the Department.

TABLE 3A: MINIMUM HWT ACCEPTANCE FREQUENCIES

Test or Action	Frequency
Hamburg Wheel Tracker	1 per 6,000 ton or at least once per Acceptance Lot

TABLE 3B: MINIMUM NUMBER OF BOXES

Sample Type	Number of Boxes
First Day Production (Taken without Mix Acceptance)	8 (4 Additional)
First Day Production (Take w/ Mix Acceptance)	8 (4 Additional)
HWT Acceptance Sample	8 (4 Additional)

Cease For ALL occurrences of cease described in the sections above, the Contractor shall submit a corrective action letter to the Resident, Materials Engineer, Pavement Quality Manager, and Pavement Quality Engineer by the end of the following work day with the proposed changes to bring the mixture back into compliance. Failure to do so will be treated as a second incident under 106.4.6 QCP Non-compliance. The Department will only allow the continuation of paving operations when it is satisfied that the corrective action will result in an improvement in results. The Department may require the submittal of a passing verification sample to allow further production.

401.201 & 401.211 Pay Adjustments Method(s) A, B, C & D The following language has been added to Section(s) 401.201 & 401.211

For items accepted under Method(s) A, B, C &D, if the mix is within the tolerances listed in Table 1A, the Department will pay the contract unit price, otherwise pay adjustments as shown in Table 4 shall be applied to the quantity of mix represented by the test. The average passes to failure will be used to determine the number of passes.

TABLE 4: HWT PAY ADJUSTMENT

Number of Passes	Pay Adjustment
< 20,000	-1.0% for every 1000 passes below target

SPECIAL PROVISION
SECTION 401 - HOT MIX ASPHALT PAVEMENT
(HMA with Fine Micro-Deval Requirement)

The following subsections of the most current version of Specification 401 – Hot Mix Asphalt Pavements have been revised and amended by the following:

401.01 Description The Contractor shall compose Hot Mix Asphalt (HMA) Pavement with aggregate, Performance Graded Asphalt Binder (PGAB), and mineral filler if required. If denoted in Special Provision 403 - Hot Mix Asphalt Pavement, the mixtures shall meet the additional aggregate requirements of this special provision.

401.02 Materials Materials shall meet the requirements specified in Section 700 – Materials, unless otherwise revised in this special provision:

Aggregates for HMA Pavement	703.07
HMA Mixture Composition	703.09

The HMA blend, minus any RAP used, shall have a Fine Micro-Deval value of 15.0 or less as determined by weighted average of individual fine aggregate source values determined through ASTM D7428.

SPECIAL PROVISION
SECTION 401
HOT MIX ASPHALT PAVEMENT
(Material Transfer Vehicle Option)

Description The Contractor may elect to use a material transfer vehicle at their option to transfer hot mix asphalt to the paver on mainline travelways, shoulders, and ramps as denoted in Special Provision 403 - Hot Mix Asphalt Pavement.

Material transfer vehicles shall operate as an independent unit not attached to the paver. It shall be a commercially manufactured unit specifically designed to transfer the hot mix from haul trucks to the paver without depositing the mix on the roadway. A separate hopper with a capacity of 14 ton shall be inserted into the regular paver hopper. The material transfer vehicle or the hopper insert shall be designed so that the mix receives additional internal mixing action either in the material transfer vehicle or the paver hopper.

Method of Measurement Hot mix asphalt pavement transferred by the material transfer vehicle and hopper insert will be measured by the ton.

Basis of Payment The accepted quantities of hot mix asphalt pavement transferred by the material transfer vehicle and hopper insert will be paid for at a price of \$2.00 per ton.

Payments will be made under:

<u>Pay Item:</u>	<u>Pay Unit:</u>
403.40 Material Transfer Vehicle (MTV)	Ton

SPECIAL PROVISION
SECTION 403
HOT MIX ASPHALT

Desc. Of Course	Grad Design.	Item Number	Total Thick	No. Of Layers	Comp. Notes
<u>Bangor Street - Variable Depth Mill & 3" HMA Overlay w/ Variable Depth Shim</u> <u>Travelway, Center Turn Lane, Shoulders & Side Roads (As Indicated)</u>					
Wearing	12.5 mm	403.2081	1 ½"	1	2,4,7,22,23,24,25,42,43
Base	12.5 mm	403.2131	1 ½"	1	2,4,7,22,23,24,41,42,43
Shim	9.5 mm	403.2111	variable	1/more	2,4,7,20,24,30,42
<u>Variable Depth Mill & 3" HMA Overlay w/ Variable Depth Shim</u> <u>Cony Circle & Approaches (Memorial Dr, Stone St, Cony St, Bangor St)</u> <u>Travelway & Shoulders (As Indicated)</u>					
Wearing	12.5 mm	403.2081	1 ½"	1	2,4,7,21,23,24,25,40,42,43,55
Base	12.5 mm	403.2131	1 ½"	1	2,4,7,21,23,24,40,41,42,43,55
Shim	9.5 mm	403.2111	variable	1/more	2,4,7,20,24,30,42,55
<u>6" HMA - Reconstruction Areas</u> <u>Travelway & Shoulders (As Indicated)</u>					
Wearing	12.5 mm	403.2081	1 ½"	1	2,4,7,21,23,24,25,40,42,55
Base	12.5 mm	403.2131	1 ½"	1	2,4,7,21,23,24,40,41,42,55
Base	12.5 mm	403.2131	3"	1	2,4,7,23,24,40,41,42,55
<u>3" HMA – Raised Crosswalks/Raised Intersections (As Indicated or Directed)</u>					
Wearing	12.5 mm	403.2081	1 ½"	1	2,4,7,23,24,30,31
Wearing	12.5 mm	403.2081	1 ½"	1	2,4,7,23,24,30,31
<u>N Belfast Ave - Variable Depth Mill & 1 ½" HMA Overlay w/ Variable Depth Shim</u> <u>Travel Lane, Turn Lane, Shoulders & Side Roads (As Indicated)</u>					
Wearing	12.5 mm	403.2081	1 ½"	1	2,4,7,21,23,24,25,42,43
Shim	9.5 mm	403.2111	variable	1/more	2,4,7,20,24,42,30
<u>N Belfast Ave - Shoulder Base Repair</u>					
Wearing	12.5 mm	403.2081	1 ½"	1	2,4,7,22,23,24,25,42
Shim	9.5 mm	403.2111	variable	1/more	2,4,7,20,24,42,30
Base	12.5 mm	403.2131	1 ½"	1	2,4,7,23,24,30
<u>6" HMA - Utility & Drainage Trenches</u> <u>Base Paving (As Indicated or Directed)</u>					
Base	12.5 mm	403.2131	3"	2/more	2,4,7,24,34,41
<u>6" HMA - Catch Basin & Curb Installation Areas</u> <u>Base Paving (As Indicated or Directed)</u>					
Base	12.5 mm	403.2131	3"	2/more	2,4,7,24,32,35,53,55
<u>Spot Shim (As Directed)</u>					
Shim	9.5 mm	403.2111	Variable	1/more	2,4,7,20,24,30
<u>Sidewalks, Drives, Islands & Misc. (As Directed)</u>					
Wearing	9.5 mm	403.209	2"-3"	1/more	3,20,30,32

COMPLEMENTARY NOTES

2. The required PGAB shall be a storage-stable, homogeneous, polymer modified asphalt binder that meets **PG 70E-28** grading requirements in AASHTO M 332. All polymer modified asphalt grades utilized on the Project shall be treated with an approved liquid anti-strip. PG binders shall be treated either at the asphalt source terminal with the required dose rate on the delivery documentation, or at the hot mix asphalt plant utilizing a system integrated with the plants controls that will introduce a minimum 0.50 percent anti-strip by weight of asphalt binder used unless a rate is otherwise recommended by the anti-strip manufacturer. The PGAB and anti-strip blend shall meet the **PG 70E-28** requirements. The Contractor shall provide supporting test data showing the PGAB and anti-strip blend meet the required criteria.
3. The aggregate qualities shall meet the design traffic level of <3 million ESALS for mix placed under this contract. The design, verification, Quality Control, and Acceptance tests for this mix will be performed at **65 gyrations**.
4. The aggregate qualities shall meet the design traffic level of 3 to <10 million ESALS for mix placed under this contract. The design, verification, Quality Control, and Acceptance tests for this mix will be performed at **65 gyrations**.
7. Section 106.6 Acceptance, (1) **Method A** as specified Section 401.20 - Quality Assurance Methods A and C.
20. The combined aggregate gradation required for this item shall be classified as a 9.5mm Thin Lift Mixture (TLM) mixture, using the Aggregate Gradation Control Points as defined in 703.09.
21. A notch wedge apparatus meeting the requirements of section 401.16 shall be required on all joints between traveled lanes. Longitudinal Joint Density incentive/disincentives will not apply, however the Department may require cores for informational purposes. In place of using a notch wedge apparatus, the Contractor may seal the vertical surface of the longitudinal joints with hot-applied asphalt sealant material, meeting the requirements of Type 4 or mastic crack seal. Sealant shall be applied to form a complete seal between each of the faces of the HMA and shall extend up the vertical surface to within ½ inch of the top of the HMA layers. This work shall be considered incidental to the contract pavement items.
22. Longitudinal joint density testing shall be applied to the specified HMA layer. See Special Provision 401 – Hot Mix Asphalt Longitudinal Joint Density for project specifics.
23. The mixture shall meet the minimum requirements of Special Provision 401 - HMA Hamburg Wheel Tracker Specification.
24. See Special Provision 401 - HMA with Fine Micro-Deval Requirement for project specifics.
25. The Contractor may, at their option, use a Material Transfer Vehicle (MTV) for **all mainline travelway and adjacent shoulders surface course** if paved in the same operation. See Special Provision 401 – Material Transfer Vehicle for specifics.
30. The incentive/disincentive provisions for density shall not apply. Rollers shall meet the requirements of this special provision. The use of an oscillating steel roller shall be required to compact all mixtures pavements placed on **bridge decks**.
31. **For Raised Crosswalks**, the compaction of the new Hot Mix Asphalt Pavement will be obtained using a minimal roller train consisting of a **10 ton** vibratory and a **3-5 Ton** finish roller for roadway work. **For Raised Intersections, an additional 10 ton oscillatory roller** will be required. A **Quality Control Technician (QCT)** shall be required for all roadway mixtures placed under this contract. A daily paving report, summarizing the mixture type, mixture temperature, equipment used, environmental conditions, and number of roller passes, shall be recorded and signed by the QCT and presented to the Department's representative by the **end of the working day**.

Augusta
025751.00 & 028356.00
Cony Circle, Bangor Street, North Belfast Avenue
Roundabout Construction, Mill & Fill
April 13, 2026

32. Compaction of the new Hot Mix Asphalt Pavement will be obtained using a minimal roller train consisting of a **3-5 ton** vibratory roller. Areas less than 2 feet wide shall be compacted with a minimum of a **150 pound** plate compactor. An approved release agent is required to ensure the mixture does not adhere to hand tools, rollers, pavers, and truck bodies. The use of petroleum based fuel oils, or asphalt stripping solvents will not be permitted.
34. The Contractor shall saw cut at a consistent width to allow transverse rolling of the trench. When applicable, a **10 ton** roller will be required. In areas inaccessible to a **10 ton** roller, compaction of the new Hot Mix Asphalt Pavement will be obtained using a minimal roller train consisting of a **3-5 ton** vibratory roller. The **minimum width of the trench shall be 5 feet** to accommodate a **3-5 ton** vibratory roller. An approved release agent is required to ensure the mixture does not adhere to hand tools, rollers, pavers, and truck bodies. The use of petroleum based fuel oils, or asphalt stripping solvents will not be permitted. Payment for additional milling or saw cutting required shall not be considered directly, but instead shall be considered incidental to the paving items.
35. The Contractor shall saw cut at a consistent width to allow compaction of mix in the trench. The minimum width of the trench shall be **2 feet** to accommodate a **150 lbs** vibratory tamper as a minimum. Payment for additional milling or saw cutting required shall not be considered directly, but instead shall be considered incidental to the paving items.
40. The entire roadway (from curb to curb, including bike lanes) shall be considered mainline travelway for density testing purposes according to the specified testing method. For density testing purposes, Station 5000+00 to 5004+00 on Bangor Street shall be considered part of the roundabout.
41. The lower lifts of base and intermediate HMA pavement (consisting of 1 ½” inches in the 3-inch section and 4 ½” inches in the 6-inch section) shall be completed before winter suspension. Any surface or base HMA placed after the seasonal limitations shall be considered temporary and removed and replaced the following construction season. The Department will not be responsible for costs or time related to the placement, removal or replacement of temporary pavement.
42. The Contractor shall plan its construction sequencing so that no longitudinal joints fall within the mainline travelway lanes (excluding center turn lanes)
43. The contractor shall mill a stepped butt joint into the existing pavement at both the beginning and end joints for each pavement layer excluding the bottom base layer. For each layer, the stepped joint shall be cut to the depth and width of the pavement layer being placed and extend 5 feet beyond the immediate underlying layer. The **butt joint** for the overlying layer shall be **completed prior** to placing the adjacent layer. The Resident may extend this length as determined by the condition of the match point. No additional payment will be made for the milling of the butt joints but will instead be considered incidental to associated paving items.
53. At the discretion of the Contractor, the use of concrete fill will be allowed in lieu of pavement and gravel to back fill around granite curbing (Type 1 & 5). When utilized, at least 3” of HMA shall be placed on top of the concrete fill for cover on the mainline edge of curb (face of curb). At minimum, the Concrete shall be a 3000 psi Class S or Class Fill Concrete. **Flowable fill shall not be permitted**. Unless otherwise specified, there will not be additional compensation for the Concrete Fill but shall be considered incidental to the 609 items.

Augusta
025751.00 & 028356.00
Cony Circle, Bangor Street, North Belfast Avenue
Roundabout Construction, Mill & Fill
April 13, 2026

55. The vertical surface of the longitudinal joint between the edge of the concrete truck apron and proposed HMA shall be completely sealed with hot-applied asphalt sealant material, meeting the requirements of Type 4 or mastic crack seal. Sealant shall be applied to form a complete seal between the concrete and HMA and shall extend up the vertical surface to within ½ inch of the top of the HMA surface layer (5.5 inches). This work shall be considered incidental to the contract pavement items.

Tack Coat

A tack coat of emulsified asphalt, RS-1, RS-1h, CRS-1 or CRS-1h, Item 409.15 shall be applied to any existing pavement at a rate of approximately 0.030 gal/yd², and on milled pavement approximately 0.050 gal/yd² prior to placing a new course. A fog coat of emulsified asphalt shall be applied between shim /base courses and surface course as well as to any bridge membrane prior to the placement of HMA layers at a rate not to exceed 0.030 gal/yd². Tack used will be **paid for at the contract unit price** for Item 409.15 Bituminous Tack Coat.

SPECIAL PROVISION
SECTION 424
ASPHALT RUBBER CRACK SEALER – Type 2

Description This work shall consist of furnishing all labor, equipment and materials necessary to clean, fill and seal longitudinal and transverse cracks in bituminous concrete pavement in accordance with this specification, an approved Quality Control Plan (QCP), and manufacturers recommendations as applicable. Work shall consist of crack cleaning and drying, material supply and heating, preparation and application material, material finishing or shaping, and providing and installing barrier material or curing materials as required.

Materials Asphalt Rubber Crack Sealer shall be an asphalt and rubber compound designed for a temperature range of 64-28 °C, and which improves the strength and performance of the base asphalt cement. Hot pour rubber crack sealant material shall conform to ASTM D-6690, Type 2.

Cone Penetration	90 max
Flow @ 60°C [140°F]	< 1/4 inch
Bond, non-immersed	Three ½ inch specimens pass 3 cycles @ 50% extension @ -20
Resilience, %	N/A
Asphalt Compatibility, ASTM D5329	pass*

* There shall be no failure in adhesion, formation of any oily exudate at the interface between the sealant and asphaltic concrete or other deleterious effects on the asphaltic concrete or sealant when tested at 140°F.

The Contractor shall provide the Resident or authorized representative with a copy of the material manufacturer's recommendations pertaining to heating, application, and reheating prior to the beginning of operations or any change in materials.

QUALITY CONTROL REQUIREMENTS

Quality Control The Contractor shall develop and submit a Quality Control Plan (QCP) that addresses the materials to be used, equipment to be used, methods of material usage (quantity measurements and tracking) as well as installation methods and protection of the work as it is completed. The Contractor shall control the work and operate in accordance with the approved QCP in order to install product and complete work meeting the contract requirements. The Contractor shall not begin sealing operations until the Department approves the QCP in writing.

Quality Control The QCP shall meet the requirements of Section 106.6 – Acceptance and this Section. The QCP shall address any items that affect the quality of the operation, and shall include the following personnel meeting these minimum requirements:

- a. QCP Administrator – The QCP Administrator must be a full-time employee of or a consultant engaged by the prime contractor or crack sealing subcontractor. The QCP Administrator shall have full authority to institute any and all actions necessary for the successful implementation of the QCP. The QCP Administrator (or their designee in the QCP Administrator’s absence) may not be required to be onsite during all work activities but shall be available to communicate with the Department as needed.
- b. Onsite Representative - The Onsite Representative (OR) shall be onsite and work directly with the crew as needed. The OR shall perform quality control inspections or measurements at the job site to assure that materials or installations meet the requirements of the contract.

The QCP shall detail the coordination of the activities of the Plan Administrator, and the OR. The Superintendent shall be named in the QCP if different than the OR, and the responsibilities for successful implementation of the QCP within the companies’ activities shall be outlined.

The QCP shall address any items that may impact the quality of the sealant installation including, but not limited to, the following:

a. General Requirements:

- Name of QCP Administrator
- Description of corrective action processes
- Remediation of defective work

b. Quality Control Plan requirements

- Name of Onsite Representative(s)
- Material type to be used (including product data sheet)
- Heating and installation temperatures
- Procedures to clean, dry and properly prepare all cracks for installation of crack sealants / fillers.
- General sealing operation activities including equipment to be used to install sealants
- Procedures to ensure that cracks are “flush filled” and any overband width does not exceed the contract requirements.
- Procedures to protect any installed sealant from damage from traffic or construction activities.

A summary of the day’s results including a quantity report, equipment used, and environmental conditions will be recorded and signed by the OR and presented to the Department’s representative by 1 PM the following working day.

Failure to adhere to the QCP, replace or repair defective or non-conforming equipment, or adjust material or installation procedures in an effort to produce work that meets the contract

requirements will result in a notification of a quality control violation resulting in monetary penalties.

A letter describing the violation shall be provided to the Contractor which will result in a mandatory work suspension and a reduction in payment as shown in Table 106.4A below. The Contractor shall submit a letter to the Department that details the corrective action made to address the violation(s) in its Quality Control Plan. Work may resume when the Department is satisfied the corrective action will result in adherence to the Quality Control Plan.

Table 106.4 A - Quality Control Pay Reduction

Quality Control Plan Value*		Pay Reduction		
From More Than	To and Including	1st	2nd	3rd & Subsequent
\$0	\$500,000	\$1,000	\$2,000	\$4,000
\$500,000	\$1,000,000	\$2,000	\$4,000	\$8,000
\$1,000,000	\$3,000,000	\$5,000	\$10,000	\$20,000
\$3,000,000	and more	\$10,000	\$20,000	\$40,000

* The Quality Control Plan Value is the total Bid value of all items covered by a Quality Control Plan, as detailed in the applicable specification or Special Provision.

Pay reductions for failure to comply with the approved QCP are cumulative, and the Department will deduct any pay reductions from amounts otherwise due the Contractor. These pay reductions are intended to encourage the Contractor to comply with its approved QCP, and are not necessarily related to the quality of the work provided.

EQUIPMENT

Equipment Equipment used in the performance of the work shall be listed in the approved QCP, and subject to Department or authorized Department representative’s approval. Equipment shall be maintained in a satisfactory working condition at all times. As a minimum, the equipment required will consist of the following:

(1) Air Compressor and air wand: A portable air compressor and air wand shall be supplied to clean the cracks to be sealed prior to using a hot air lance. The air compressor shall be coupled with hose and air wand and be capable of furnishing not less than 150 CFM of air and not less than 100 psi pressure through a 5/8”- inch diameter nozzle. A ½ -inch or ¾-inch nozzle may be used with approval of the Inspector as long as the pressure requirements are being met. The compressor shall be equipped with traps that will maintain the compressed air free of oil and water. A single air compressor may be utilized to supply air to both the air wand and hot air lance with the condition that it will consistently supply the required air volume and pressures for each operation simultaneously.

(2) Sweeper: Manually operated, gas powered air-broom or self-propelled sweeper designed especially for use in cleaning highway and airfield pavements shall be used to remove debris, dirt, and dust from the cracks.

(3) Hot Air Lance: The hot air lance shall be independent of the air wand unit. The hot air lance shall be operated with propane and compressed air in combination and provide 1000 ft/sec of heated air at 2000°F - 3000°F. The lance should draw propane from no smaller than a 100 lb tank using separate hoses for propane and air draw. The hoses shall be wrapped together with reflectorized wrap to keep them together and to protect workers in low light situations. A single air compressor may be utilized to supply air to both the air wand and hot air lance with the condition that it will consistently supply the required air volume and pressures for each operation simultaneously.

(4) Hand Tools: Hand tools shall consist of shall consist of brooms, shovels, metal bars with chisel shaped ends, and any other tools which may be satisfactorily used to prepare cracks to be sealed. Other tools such as, but not limited to, V-shaped squeegee or flat squeegee may be necessary to prevent excessive overband width and thickness.

(5) Melting Kettle: The unit used to melt the joint sealing compound shall be a double boiler, indirect fired type. The space between inner and outer shells shall be filled with a suitable heat transfer oil or substitute having a flash point of not less than 608°F. The kettle shall be equipped with a satisfactory means of agitating and mixing the joint sealer at all times. This may be accomplished by continuous stirring with mechanically operated paddles and/or a continuous circulating gear pump attached to the heating unit. The kettle must be equipped with thermostatic control calibrated between 200°F and 550°F. The Contractor shall either provide a jacketed thermometer that accurately displays the sealant temperature within the kettle or provide the Resident or authorized representative with a suitable device for verifying the sealant temperature in the kettle. Temperatures must be able to be checked at any time during the heating of material, application of material, or at the end of the application operation.

The Contractor shall inspect all equipment utilized in the crack seal operations, including the crack cleaning, crack heating, and crack drying operations as well as the crack sealant heating, mixing, crack filling and crack finishing equipment to assure the final product meets the requirements of the contract. The QCP shall detail how these duties and responsibilities are to be accomplished and documented, and whether more than one OR is required. The QCP shall include the criteria utilized by the QCT to correct or reject unsatisfactory materials.

GENERAL CONSTRUCTION REQUIREMENTS

Weather Asphalt Rubber Crack Sealer shall not be applied on a wet surface, or when the atmospheric temperature is below 50°F in a shaded area at the job site, or when weather conditions are otherwise unfavorable to proper construction procedures.

Preparations of Cracks All cracks shall be blown free of loose material, dirt, vegetation, and other debris by high pressure air prior to the used of the hot air lance. Material removed from the crack shall be removed from the pavement surface by means of compressed air, power sweeper or appropriate hand tools as required. Cracks showing evidence of vegetation after being blown out shall be additionally cleaned by appropriate hand tools and additionally blown out. All cracks must be blown clean with the high-pressure air wand in advance of the hot air lance. All cracks shall be heated via the hot air lance no more than 5 minutes prior to the crack being sealed. Distance between the hot air lance and the crack sealing unit should be no more than 50 ft to eliminate re-invasion of water, debris, and other incompressible materials. All debris, vegetation,

and water shall be removed to enhance adhesion of the crack sealing material. THIS WORK SHALL NOT BE DONE IN INCLEMENT WEATHER.

Preparation and Placement of Sealer The rubber crack sealer material shall be heated and applied at the temperature specified by the manufacturer and approved by the Resident or authorized representative. Any material that has been heated above the manufacturer's specification shall not be used. Material that is reheated or held at temperature for an extended period of time may be used as allowed by the manufacturer's specification and approval of the Resident or authorized representative. A copy of the manufacture's specification shall be provided to the Project when requested.

The Contractor shall provide the Resident or authorized representative with a suitable device for verifying the sealant temperature in the kettle and at the application site.

Any loose material on the surface or in the crack, which may contaminate the crack sealer or impede bonding of the sealant to the pavement, is to be removed by hand tools prior to crack filling. No crack filling material shall be applied in a crack that is wet or where frost, snow, or ice is present. The ambient air temperature must be 50 or higher.

Any over application or spills are to be removed to the satisfaction of the Resident or authorized representative. Any sealed areas with damaged or contaminated sealer or visible voids are to be removed, prepared and resealed. Defective or leaking valves and wands will be repaired or replaced before work continues. If repairs or replacement of defective equipment cannot be accomplished immediately then the Department may permit work to continue but deduct any excess quantities placed as it determines.

Cracks ½ inch up to 1 ½ inch in may be sealed with Type II crack seal. Generally, repairs wider than 1 ½ inches or those that extend below the surface layer may require a change to different sealant material type or treatment method in order repair cracks.

For projects where sealants will be covered and a hot mix asphalt overlay is being installed over the sealant all cracks will be "**flush filled**", meaning cracks are filled to a point that the sealant is flush with the existing pavement surface. If the work scope requires a flush fill a nozzle sized to fill the cracks shall be used. Minimal to no overbanding will be permitted. The applicator shoe width shall be a maximum of 2 inches and produce a sealer width range from 1 inch – 1.5 inch. Overall width of the sealant may vary from the range specified depending on the width and severity of the cracks with approval from the Department.

For projects where the sealants are left un-covered with a hot mix overlay and traffic will be permitted to travel over the sealants for the anticipated sealant life, some overband may be permitted. If the work scope required crack filling and sealing with overband, then a shoe sized to meet the overband width shall be used. The applicator shoe width shall be a maximum of 2 inches and produce a sealer overband range from 1 inch – 1.5 inch. Overbanding width may vary from the range specified depending on the width and severity of the cracks with approval from the Department.

Sealer shall be delivered to the crack while the cracks are still hot from the hot air lance preparation through a pressure hose line and applicator nozzle or shoe.

The applicator shall be followed by a V-shaped squeegee to minimize the thickness of any overband. The sealer shall be applied at a rate that produces a coating thickness of 1/8 - inch, typical.

If the sealed area is to be opened to traffic immediately, a barrier material (de-tackifier) such as Glenzoil, Black Beauty grit, or an equivalent product approved by the Resident shall be provided by the Contractor and shall be applied to the crack sealer to prevent pickup as directed by the Resident or authorized representative.

If sealed areas are to be paved over with a hot mix asphalt treatment a 48 hour minimum cure time and use of barrier material (de-tackifier) will be required. Cure times may be extended if excessive pick-up of the crack sealants occurs.

Quality of Work Any excess of sealer, spilled or overapplied, shall be removed from the pavement by approved methods and discarded. Any quality of work determined to be below normal acceptable standards will not be accepted and will be corrected and/or replaced as directed by the Resident or authorized representative.

Method of Measurement Asphalt Rubber Crack Sealer will be measured by the pound of sealant used. The manufacturer's weights of the sealant for each block (pill), counted as they are loaded, will be accepted as a basis for measurement.

Should tank checks be approved to verify material usage or calculate initial or final gallons remaining in the tanker, a calibrated tank gauge or tank stick shall be used to measure the tank gallons. Volume corrections shall be calculated using Table:1 to correct the gallon volume to 60 ° F.

For those approved cases the Department has determined the weight of this material to be 9.7 pounds per gallon. The Department will use this conversion value for all materials measured by the gallon and converted to pounds. The corrected volume and resultant pounds shall be made part of the method of measurement, with consideration given to blocks (pills) added during the day and applied in an acceptable manner

Basis of Payment The accepted quantity of Asphalt Rubber Crack Sealer will be paid for at the contract unit price per pound complete in place. This price shall be full compensation for furnishing and placing crack sealer, including cleaning cracks and furnishing and placing barrier materials if necessary.

Payment will be made under:

<u>Pay Item</u>	<u>Pay Unit</u>
424.22 Asphalt Rubber Crack Sealer Type 2, Applied	Pound

Conversion Table:1

t	M	t	M	t	M	t	M	t	M	t	M
100	0.9861	135	0.9740	170	0.9621	205	0.9503	240	0.9385	275	0.9269
101	0.9857	136	0.9737	171	0.9618	206	0.9499	241	0.9382	276	0.9266
102	0.9854	137	0.9734	172	0.9614	207	0.9496	242	0.9379	277	0.9263
103	0.9851	138	0.9730	173	0.9611	208	0.9493	243	0.9375	278	0.9259
104	0.9847	139	0.9727	174	0.9607	209	0.9489	244	0.9372	279	0.9256
105	0.9844	140	0.9723	175	0.9604	210	0.9486	245	0.9369	280	0.9253
106	0.9840	141	0.9720	176	0.9601	211	0.9483	246	0.9365	281	0.9250
107	0.9837	142	0.9716	177	0.9597	212	0.9479	247	0.9362	282	0.9246
108	0.9833	143	0.9713	178	0.9594	213	0.9476	248	0.9359	283	0.9243
109	0.9830	144	0.9710	179	0.9590	214	0.9472	249	0.9356	284	0.9240
110	0.9826	145	0.9706	180	0.9587	215	0.9469	250	0.9352	285	0.9236
111	0.9823	146	0.9703	181	0.9584	216	0.9466	251	0.9349	286	0.9233
112	0.9819	147	0.9699	182	0.9580	217	0.9462	252	0.9346	287	0.9230
113	0.9816	148	0.9696	183	0.9577	218	0.9459	253	0.9342	288	0.9227
114	0.9813	149	0.9693	184	0.9574	219	0.9456	254	0.9339	289	0.9223
115	0.9809	150	0.9689	185	0.9570	220	0.9452	255	0.9336	290	0.9220
116	0.9806	151	0.9686	186	0.9567	221	0.9449	256	0.9332	291	0.9217
117	0.9802	152	0.9682	187	0.9563	222	0.9446	257	0.9329	292	0.9213
118	0.9799	153	0.9679	188	0.9560	223	0.9442	258	0.9326	293	0.9210
119	0.9795	154	0.9675	189	0.9557	224	0.9439	259	0.9322	294	0.9207
120	0.9792	155	0.9672	190	0.9553	225	0.9436	260	0.9319	295	0.9204
121	0.9788	156	0.9669	191	0.9550	226	0.9432	261	0.9316	296	0.9200
122	0.9785	157	0.9665	192	0.9547	227	0.9429	262	0.9312	297	0.9197
123	0.9782	158	0.9662	193	0.9543	228	0.9426	263	0.9309	298	0.9194
124	0.9778	159	0.9658	194	0.9540	229	0.9422	264	0.9306	299	0.9190
125	0.9775	160	0.9655	195	0.9536	230	0.9419	265	0.9302	300	0.9187
126	0.9771	161	0.9652	196	0.9533	231	0.9416	266	0.9299	301	0.9184
127	0.9768	162	0.9648	197	0.9530	232	0.9412	267	0.9296	302	0.9181
128	0.9764	163	0.9645	198	0.9526	233	0.9409	268	0.9293	303	0.9177
129	0.9761	164	0.9641	199	0.9523	234	0.9405	269	0.9289	304	0.9174
130	0.9758	165	0.9638	200	0.9520	235	0.9402	270	0.9286	305	0.9171
131	0.9754	166	0.9635	201	0.9516	236	0.9399	271	0.9283	306	0.9167
132	0.9751	167	0.9631	202	0.9513	237	0.9395	272	0.9279	307	0.9164
133	0.9747	168	0.9628	203	0.9509	238	0.9392	273	0.9276	308	0.9161
134	0.9744	169	0.9624	204	0.9505	239	0.9389	274	0.9273	309	0.9158

Legend: t = observed temperature in degrees Fahrenheit.
M = multiplier for reducing volumes to the basis of 60° F.

Conversion Table:1

t	M	t	M	t	M	t	M	t	M
310	0.9154	350	0.9024	390	0.8896	430	0.8768	470	0.8643
311	0.9151	351	0.9021	391	0.8892	431	0.8765	471	0.8640
312	0.9148	352	0.9018	392	0.8889	432	0.8762	472	0.8636
313	0.9145	353	0.9015	393	0.8886	433	0.8759	473	0.8633
314	0.9141	354	0.9011	394	0.8883	434	0.8756	474	0.8630
315	0.9138	355	0.9008	395	0.8880	435	0.8753	475	0.8627
316	0.9135	356	0.9005	396	0.8876	436	0.8749	476	0.8624
317	0.9132	357	0.9002	397	0.8873	437	0.8746	477	0.8621
318	0.9128	358	0.8998	398	0.8870	438	0.8743	478	0.8618
319	0.9125	359	0.8995	399	0.8867	439	0.8740	479	0.8615
320	0.9122	360	0.8992	400	0.8864	440	0.8737	480	0.8611
321	0.9118	361	0.8989	401	0.8861	441	0.8734	481	0.8608
322	0.9115	362	0.8986	402	0.8857	442	0.8731	482	0.8605
323	0.9112	363	0.8982	403	0.8854	443	0.8727	483	0.8602
324	0.9109	364	0.8979	404	0.8851	444	0.8724	484	0.8599
325	0.9105	365	0.8976	405	0.8848	445	0.8721	485	0.8596
326	0.9102	366	0.8973	406	0.8845	446	0.8718	486	0.8593
327	0.9099	367	0.8969	407	0.8841	447	0.8715	487	0.8590
328	0.9096	368	0.8966	408	0.8838	448	0.8712	488	0.8587
329	0.9092	369	0.8963	409	0.8835	449	0.8709	489	0.8583
330	0.9089	370	0.8960	410	0.8832	450	0.8705	490	0.8580
331	0.9086	371	0.8957	411	0.8829	451	0.8702	491	0.8577
332	0.9083	372	0.8953	412	0.8826	452	0.8699	492	0.8574
333	0.9079	373	0.8950	413	0.8822	453	0.8696	493	0.8571
334	0.9076	374	0.8947	414	0.8819	454	0.8693	494	0.8568
335	0.9073	375	0.8944	415	0.8816	455	0.8690	495	0.8565
336	0.9070	376	0.8941	416	0.8813	456	0.8687	496	0.8562
337	0.9066	377	0.8937	417	0.8810	457	0.8683	497	0.8559
338	0.9063	378	0.8934	418	0.8806	458	0.8680	498	0.8556
339	0.9060	379	0.8931	419	0.8803	459	0.8677	499	0.8552
340	0.9057	380	0.8928	420	0.8800	460	0.8674		
341	0.9053	381	0.8924	421	0.8797	461	0.8671		
342	0.9050	382	0.8921	422	0.8794	462	0.8668		
343	0.9047	383	0.8918	423	0.8791	463	0.8665		
344	0.9044	384	0.8915	424	0.8989	464	0.8661		
345	0.9040	385	0.8912	425	0.8984	465	0.8658		
346	0.9037	386	0.8908	426	0.8781	466	0.8655		
347	0.9034	387	0.8905	427	0.8778	467	0.8652		
348	0.9031	388	0.8902	428	0.8775	468	0.8649		
349	0.9028	389	0.8899	429	0.8772	469	0.8646		

Legend: t = observed temperature in degrees Fahrenheit.
M = multiplier for reducing volumes to the basis of 60° F.

SPECIAL PROVISION
SECTION 424
Mastic-Based Crack Sealing

Description This work shall consist of furnishing all labor, equipment and materials necessary to clean, fill and seal longitudinal and transverse cracks in bituminous concrete pavement courses. Materials are to be thoroughly applied to seal the cracks. This work shall consist of the furnishing and placement of mastic-based crack sealing material in the cracks of existing bituminous concrete pavement in accordance with these Special Provisions. This work shall consist of crack cleaning and drying, material supply and heating, preparation and application material, material finishing or shaping, and providing and installing barrier material or curing materials as required.

The Department will allow mastic-based sealing materials as an option for Ultra-Thin Bonded Wearing Course (UTBWC) and other treatments that specify Type 2 or Type 4 sealants in the contract. If the option to utilize Mastic based sealing materials is requested the change shall be subject to approval by the Department prior to the start of work, and sealant and equipment requirements shall meet the following criteria.

MATERIALS

The mastic-based materials are hot-applied, pourable, self-adhesive mastics designed for maintenance and repair of asphalt and Portland cement concrete pavements. Hot pour mastic materials are composed of highly modified polymer asphalt binder and up to 2% synthetic fiber (by weight) as required by the application and approved by the Department.

Mastic based sealing materials shall be delivered in the manufacturer’s original container. Mastic material based sealing materials shall be pre-packaged with the manufacturers name and product name marked on each container. The materials shall conform to the following requirements:

Parameter

Color	Black
Pourability @ 400F (PTM1)*	1000-1400 gm
Stability @ 158F (PTM2)	.6in. max
Flexibility @ Low Temperature (PTM3)	Pass @ -20F
Adhesion @77F (PTM4)	15psi min.
Specific Gravity (ASTM D792)	1.35max.
Skid Resistance, BPN (ASTM E303)	40 min.
Minimum Application Temperature	375°F
Maximum Application Temperature	410°F

QUALITY CONTROL REQUIREMENTS

Quality Control The Contractor shall develop and submit a Quality Control Plan (QCP) that addresses the materials to be used, equipment to be used, methods of material usage (quantity measurements and tracking) as well as installation methods and protection of the work as it is completed. The Contractor shall control the work and operate in accordance with the approved QCP in order to install product and complete work meeting the contract requirements. The Contractor shall not begin sealing operations until the Department approves the QCP in writing.

Quality Control The QCP shall meet the requirements of Section 106.6 – Acceptance and this Section. The QCP shall address any items that affect the quality of the operation, and shall include the following personnel meeting these minimum requirements:

- a. QCP Administrator – The QCP Administrator must be a full-time employee of or a consultant engaged by the prime contractor or crack sealing subcontractor. The QCP Administrator shall have full authority to institute any and all actions necessary for the successful implementation of the QCP. The QCP Administrator (or their designee in the QCP Administrator’s absence) may not be required to be onsite during all work activities but shall be available to communicate with the Department as needed.
- b. Onsite Representative - The Onsite Representative (OR) shall be onsite and work directly with the crew as needed. The OR shall perform quality control inspections or measurements at the job site to assure that materials or installations meet the requirements of the contract.

The QCP shall detail the coordination of the activities of the Plan Administrator, and the OR. The Superintendent shall be named in the QCP if different than the OR, and the responsibilities for successful implementation of the QCP within the companies’ activities shall be outlined.

The QCP shall address any items that may impact the quality of the sealant installation including, but not limited to, the following:

- a. General Requirements:
 - Name of QCP Administrator
 - Description of corrective action processes
 - Remediation of defective work
- b. Quality Control Plan requirements
 - Name of Onsite Representative(s)
 - Material type to be used (including product data sheet)
 - Heating and installation temperatures

- Procedures to clean, dry and properly prepare all cracks for installation of crack sealants / fillers.
- General sealing operation activities including equipment to be used to install sealants
- Procedures to ensure that cracks are “flush filled” and any overband width does not exceed the contract requirements.
- Procedures to protect any installed sealant from damage from traffic or construction activities.

A summary of the day’s results including a quantity report, equipment used, and environmental conditions will be recorded and signed by the OR and presented to the Department’s representative by 1 PM the following working day.

Failure to adhere to the QCP, replace or repair defective or non-conforming equipment, or adjust material or installation procedures in an effort to produce work that meets the contract requirements will result in a notification of a quality control violation resulting in monetary penalties.

A letter describing the violation shall be provided to the Contractor which will result in a mandatory work suspension and a reduction in payment as shown in Table 106.4A below. The Contractor shall submit a letter to the Department that details the corrective action made to address the violation(s) in its Quality Control Plan. Work may resume when the Department is satisfied the corrective action will result in adherence to the Quality Control Plan.

Table 106.4 A - Quality Control Pay Reduction

Quality Control Plan Value*		Pay Reduction		
From More Than	To and Including	1st	2nd	3rd & Subsequent
\$0	\$500,000	\$1,000	\$2,000	\$4,000
\$500,000	\$1,000,000	\$2,000	\$4,000	\$8,000
\$1,000,000	\$3,000,000	\$5,000	\$10,000	\$20,000
\$3,000,000	and more	\$10,000	\$20,000	\$40,000

* The Quality Control Plan Value is the total Bid value of all items covered by a Quality Control Plan, as detailed in the applicable specification or Special Provision.

Pay reductions for failure to comply with the approved QCP are cumulative, and the Department will deduct any pay reductions from amounts otherwise due the Contractor. These pay reductions are intended to encourage the Contractor to comply with its approved QCP, and are not necessarily related to the quality of the work provided.

EQUIPMENT

Equipment Equipment used in the performance of the work shall be subject to the Resident's or authorized representative's approval and shall be maintained in a satisfactory working condition at all times. As a minimum, the equipment required will consist of the following:

(1) Air Compressor and air wand: A portable air compressor and air wand shall be supplied to clean the cracks to be sealed prior to using a hot air lance. The air compressor shall be coupled with hose and air wand and be capable of furnishing not less than 150 CFM of air and not less than 100 psi pressure through a 5/8"- inch diameter nozzle. A 1/2 - inch or 3/4-inch nozzle may be used with approval of the Inspector as long as the pressure requirements are being met. The compressor shall be equipped with traps that will maintain the compressed air free of oil and water. A single air compressor may be utilized to supply air to both the air wand and hot air lance with the condition that it will consistently supply the required air volume and pressures for each operation simultaneously.

(2) Sweeper: Manually operated, gas powered air-broom or self-propelled sweeper designed especially for use in cleaning highway and airfield pavements shall be used to remove debris, dirt, and dust from the cracks.

(3) Hot Air Lance: The hot air lance shall be independent of the air wand unit. The hot air lance shall be operated with propane and compressed air in combination and provide 1000 ft/sec of heated air at 2000°F - 3000°F. The lance should draw propane from no smaller than a 100 lb tank using separate hoses for propane and air draw. The hoses shall be wrapped together with reflectorized wrap to keep them together and to protect workers in low light situations. A single air compressor may be utilized to supply air to both the air wand and hot air lance with the condition that it will consistently supply the required air volume and pressures for each operation simultaneously.

(4) Hand Tools: Hand tools shall consist of shall consist of brooms, shovels, metal bars with chisel shaped ends, and any other tools which may be satisfactorily used to prepare cracks to be sealed. Other tools such as, but not limited to, V-shaped squeegee or flat squeegee may be necessary to prevent excessive overband width and thickness.

(5) Melting Kettle: The unit used to melt the mastic-based crack sealing material shall be a double boiler, indirect fired type. The space between inner and outer shells shall be filled with a suitable heat transfer oil or substitute having a flash point of not less than 608°F. The kettle shall be equipped with a satisfactory means of agitating and mixing the joint sealer at all times. This may be accomplished by continuous stirring with mechanically operated paddles and/or a continuous circulating gear pump attached to the heating unit. The kettle must be equipped with thermostatic control calibrated between 200°F and 550°F. The Contractor shall either provide a jacketed thermometer that accurately displays the sealant temperature within the kettle or provide the Resident or

authorized representative with a suitable device for verifying the sealant temperature in the kettle. Temperatures must be able to be checked at any time during the heating of material, application of material, or at the end of the application operation.

GENERAL CONSTRUCTION REQUIREMENTS

Weather Mastic based crack sealing materials shall not be applied on a wet surface, or when the atmospheric temperature is below 45 °F in a shaded area at the job site, or when weather conditions are otherwise unfavorable to proper construction procedures.

Preparations of Cracks All cracks shall be blown free of loose material, dirt, vegetation, and other debris by high pressure air prior to the used of the hot air lance. Material removed from the crack shall be removed from the pavement surface by means of compressed air, power sweeper or appropriate hand tools as required. Cracks showing evidence of vegetation after being blown out shall be additionally cleaned by appropriate hand tools and additionally blown out. All cracks must be blown clean with the high-pressure air wand in advance of the hot air lance. All cracks shall be heated via the hot air lance no more than 5 minutes prior to the crack being sealed. Distance between the hot air lance and the crack sealing unit should be no more than 50 ft to eliminate re-invasion of water, debris, and other incompressible materials. All debris, vegetation, and water shall be removed to enhance adhesion of the crack sealing material. THIS WORK SHALL NOT BE DONE IN INCLEMENT WEATHER.

Preparation and Placement of Sealer Mastic based crack sealing material shall be heated and applied at the temperature specified by the manufacturer and approved by the Resident or authorized representative. Any material that has been heated above the manufacturer's specification shall not be used. Material that is reheated or held at temperature for an extended period of time may be used as allowed by the manufacturer's specification and approval of the Resident or authorized representative. A copy of the manufacture's specification shall be provided to the Project when requested.

The Contractor shall provide the Resident or authorized representative with a suitable device for verifying the sealant temperature in the kettle and at the application site.

Any loose material on the surface or in the crack, which may contaminate the crack sealer or impede bonding of the sealant to the pavement, is to be removed by hand tools prior to crack filling. No crack filling material shall be applied in a crack that is wet or where frost, snow, or ice is present. The ambient air temperature must be 50 or higher.

Any over application or spills are to be removed to the satisfaction of the Resident or authorized representative. Any sealed areas with damaged or contaminated sealer or visible voids are to be removed, prepared and resealed. Defective or leaking valves and wands will be repaired or replaced before work continues. If repairs or replacement of defective equipment cannot be accomplished immediately then the Department may permit work to continue but deduct any excess quantities placed as it determines.

Cracks ½ inch up to 1 ½ inch in may be sealed with mastic-based crack seal. Generally, repairs wider than 1 ½ inches or those that extend below the surface layer may require a change to different mastic material type or treatment method in order repair cracks.

For projects where mastic-based crack sealing materials will be covered and a hot mix asphalt overlay is being installed over the sealant all cracks will be “**flush filled**”, meaning cracks are filled to a point that the sealant is flush with the existing pavement surface. If the work scope requires a flush fill a nozzle sized to fill the cracks shall be used. Minimal to no overbanding will be permitted.

For projects where the mastic-based crack sealing materials are left un-covered with a hot mix overlay and traffic will be permitted to travel over the sealants for the anticipated sealant life, some overband may be permitted.

If the work scope allows crack filling and sealing with overband, then a shoe sized to meet the overband width shall be used. Generally, the shoe width and the sealer overbanding area shall range from 1 inch – 1.5 inch. Overbanding width may vary from the range specified depending on the width and severity of the cracks.

Sealer shall be delivered to the crack while the cracks are still hot from the hot air lance preparation through a pressure hose line and applicator nozzle or shoe.

The applicator shall be followed by a V-shaped squeegee to minimize the thickness of any overband. The sealer shall be applied at a rate that produces a coating thickness of 3/32 - inch, typical.

If the sealed area is to be opened to traffic immediately, a barrier material (de-tackifier) such as Glenzoil, Black Beauty grit, or an equivalent product approved by the Resident shall be provided by the Contractor and shall be applied to the crack sealer to prevent pickup as directed by the Resident or authorized representative.

If sealed areas are to be paved over with a hot mix asphalt treatment then a 48 hour minimum cure time and use of barrier material (de-tackifier) will be required. Cure times may be extended if excessive pick-up of the crack sealants occurs.

Quality of Work Any excess of sealer, spilled or overapplied, shall be removed from the pavement by approved methods and discarded. Any quality of work determined to be below normal acceptable standards will not be accepted and will be corrected and/or replaced as directed by the Resident or authorized representative.

Method of Measurement Mastic based crack sealing materials will be measured by the pound of sealant used. The manufacturer’s weights of the sealant for each block (pill), counted as they are loaded, will be accepted as a basis for measurement.

Should tank checks be approved to verify material usage or calculate initial or final gallons remaining in the tanker, a calibrated tank gauge or tank stick shall be used to

measure the tank gallons. Volume corrections shall be calculated using Table:1 to correct the gallon volume to 60 ° F.

For those approved cases the Department has determined the weight of this material to be 10.63 pounds per gallon. The Department will use this conversion value for all materials measured by the gallon and converted to pounds. The corrected volume and resultant pounds shall be made part of the method of measurement, with consideration given to blocks (pills) added during the day and applied in an acceptable manner

Basis of Payment The accepted quantity of Mastic-Based Crack Sealing will be paid for at the contract unit price per pound complete in place. This price shall be full compensation for furnishing and placing crack sealer, including cleaning cracks and furnishing and placing barrier materials if necessary.

Conversion Table:1

t	M	t	M	t	M	t	M	t	M	t	M
100	0.9861	135	0.9740	170	0.9621	205	0.9503	240	0.9385	275	0.9269
101	0.9857	136	0.9737	171	0.9618	206	0.9499	241	0.9382	276	0.9266
102	0.9854	137	0.9734	172	0.9614	207	0.9496	242	0.9379	277	0.9263
103	0.9851	138	0.9730	173	0.9611	208	0.9493	243	0.9375	278	0.9259
104	0.9847	139	0.9727	174	0.9607	209	0.9489	244	0.9372	279	0.9256
105	0.9844	140	0.9723	175	0.9604	210	0.9486	245	0.9369	280	0.9253
106	0.9840	141	0.9720	176	0.9601	211	0.9483	246	0.9365	281	0.9250
107	0.9837	142	0.9716	177	0.9597	212	0.9479	247	0.9362	282	0.9246
108	0.9833	143	0.9713	178	0.9594	213	0.9476	248	0.9359	283	0.9243
109	0.9830	144	0.9710	179	0.9590	214	0.9472	249	0.9356	284	0.9240
110	0.9826	145	0.9706	180	0.9587	215	0.9469	250	0.9352	285	0.9236
111	0.9823	146	0.9703	181	0.9584	216	0.9466	251	0.9349	286	0.9233
112	0.9819	147	0.9699	182	0.9580	217	0.9462	252	0.9346	287	0.9230
113	0.9816	148	0.9696	183	0.9577	218	0.9459	253	0.9342	288	0.9227
114	0.9813	149	0.9693	184	0.9574	219	0.9456	254	0.9339	289	0.9223
115	0.9809	150	0.9689	185	0.9570	220	0.9452	255	0.9336	290	0.9220
116	0.9806	151	0.9686	186	0.9567	221	0.9449	256	0.9332	291	0.9217
117	0.9802	152	0.9682	187	0.9563	222	0.9446	257	0.9329	292	0.9213
118	0.9799	153	0.9679	188	0.9560	223	0.9442	258	0.9326	293	0.9210
119	0.9795	154	0.9675	189	0.9557	224	0.9439	259	0.9322	294	0.9207
120	0.9792	155	0.9672	190	0.9553	225	0.9436	260	0.9319	295	0.9204
121	0.9788	156	0.9669	191	0.9550	226	0.9432	261	0.9316	296	0.9200
122	0.9785	157	0.9665	192	0.9547	227	0.9429	262	0.9312	297	0.9197
123	0.9782	158	0.9662	193	0.9543	228	0.9426	263	0.9309	298	0.9194
124	0.9778	159	0.9658	194	0.9540	229	0.9422	264	0.9306	299	0.9190
125	0.9775	160	0.9655	195	0.9536	230	0.9419	265	0.9302	300	0.9187
126	0.9771	161	0.9652	196	0.9533	231	0.9416	266	0.9299	301	0.9184
127	0.9768	162	0.9648	197	0.9530	232	0.9412	267	0.9296	302	0.9181
128	0.9764	163	0.9645	198	0.9526	233	0.9409	268	0.9293	303	0.9177
129	0.9761	164	0.9641	199	0.9523	234	0.9405	269	0.9289	304	0.9174
130	0.9758	165	0.9638	200	0.9520	235	0.9402	270	0.9286	305	0.9171
131	0.9754	166	0.9635	201	0.9516	236	0.9399	271	0.9283	306	0.9167
132	0.9751	167	0.9631	202	0.9513	237	0.9395	272	0.9279	307	0.9164
133	0.9747	168	0.9628	203	0.9509	238	0.9392	273	0.9276	308	0.9161
134	0.9744	169	0.9624	204	0.9505	239	0.9389	274	0.9273	309	0.9158

Legend: t = observed temperature in degrees Fahrenheit.
M = multiplier for reducing volumes to the basis of 60° F.

Conversion Table:1

t	M	t	M	t	M	t	M	t	M
310	0.9154	350	0.9024	390	0.8896	430	0.8768	470	0.8643
311	0.9151	351	0.9021	391	0.8892	431	0.8765	471	0.8640
312	0.9148	352	0.9018	392	0.8889	432	0.8762	472	0.8636
313	0.9145	353	0.9015	393	0.8886	433	0.8759	473	0.8633
314	0.9141	354	0.9011	394	0.8883	434	0.8756	474	0.8630
315	0.9138	355	0.9008	395	0.8880	435	0.8753	475	0.8627
316	0.9135	356	0.9005	396	0.8876	436	0.8749	476	0.8624
317	0.9132	357	0.9002	397	0.8873	437	0.8746	477	0.8621
318	0.9128	358	0.8998	398	0.8870	438	0.8743	478	0.8618
319	0.9125	359	0.8995	399	0.8867	439	0.8740	479	0.8615
320	0.9122	360	0.8992	400	0.8864	440	0.8737	480	0.8611
321	0.9118	361	0.8989	401	0.8861	441	0.8734	481	0.8608
322	0.9115	362	0.8986	402	0.8857	442	0.8731	482	0.8605
323	0.9112	363	0.8982	403	0.8854	443	0.8727	483	0.8602
324	0.9109	364	0.8979	404	0.8851	444	0.8724	484	0.8599
325	0.9105	365	0.8976	405	0.8848	445	0.8721	485	0.8596
326	0.9102	366	0.8973	406	0.8845	446	0.8718	486	0.8593
327	0.9099	367	0.8969	407	0.8841	447	0.8715	487	0.8590
328	0.9096	368	0.8966	408	0.8838	448	0.8712	488	0.8587
329	0.9092	369	0.8963	409	0.8835	449	0.8709	489	0.8583
330	0.9089	370	0.8960	410	0.8832	450	0.8705	490	0.8580
331	0.9086	371	0.8957	411	0.8829	451	0.8702	491	0.8577
332	0.9083	372	0.8953	412	0.8826	452	0.8699	492	0.8574
333	0.9079	373	0.8950	413	0.8822	453	0.8696	493	0.8571
334	0.9076	374	0.8947	414	0.8819	454	0.8693	494	0.8568
335	0.9073	375	0.8944	415	0.8816	455	0.8690	495	0.8565
336	0.9070	376	0.8941	416	0.8813	456	0.8687	496	0.8562
337	0.9066	377	0.8937	417	0.8810	457	0.8683	497	0.8559
338	0.9063	378	0.8934	418	0.8806	458	0.8680	498	0.8556
339	0.9060	379	0.8931	419	0.8803	459	0.8677	499	0.8552
340	0.9057	380	0.8928	420	0.8800	460	0.8674		
341	0.9053	381	0.8924	421	0.8797	461	0.8671		
342	0.9050	382	0.8921	422	0.8794	462	0.8668		
343	0.9047	383	0.8918	423	0.8791	463	0.8665		
344	0.9044	384	0.8915	424	0.8989	464	0.8661		
345	0.9040	385	0.8912	425	0.8984	465	0.8658		
346	0.9037	386	0.8908	426	0.8781	466	0.8655		
347	0.9034	387	0.8905	427	0.8778	467	0.8652		
348	0.9031	388	0.8902	428	0.8775	468	0.8649		
349	0.9028	389	0.8899	429	0.8772	469	0.8646		

Legend: t = observed temperature in degrees Fahrenheit.
M = multiplier for reducing volumes to the basis of 60° F.

SPECIAL PROVISION
SECTION 424
POLYMER MODIFIED ASPHALT CRACK SEALANT w/ FIBER

Description This work shall consist of crack cleaning utilizing compressed air and hand tools as required to prepare cracks for sealant installation, drying of the prepared cracks, material supply and heating, preparation and application of material, material finishing or shaping, and providing and installing barrier material or curing materials used to seal longitudinal and transverse cracks in bituminous concrete pavements as directed and in accordance with these Special Provisions.

The Department will allow Polymer Modified Asphalt Crack Sealant with fiber as an option for Ultra-Thin Bonded Wearing Course (UTBWC) and other treatments that specify Type 2 or Type 4 sealants in the contract. If the option to utilize Polymer Modified Asphalt Crack Sealant with fiber is selected the sealant and equipment requirements shall meet the following criteria and shall be subject to approval by the Department prior to the start of work.

MATERIALS

Polymer Modified Asphalt Crack Sealant with fiber (PMACS) shall be a polymer modified asphalt-fiber compound designed specifically for improving the strength and performance of the parent asphalt used in the sealant.

The asphalt binder shall consist of a blend of neat asphalt binder, crumb rubber, and SBS polymer and meet the following specifications:

- Modification at a minimum shall consist 7% crumb rubber and 3-4% SBS polymer. The maximum particle size for the crumb rubber shall be 80 mesh
- The performance grade of the base asphalt binder prior to modification shall be a PG 58-28
- OB DSR (AASHTO T315) @ 76: Min 1.00 kPa
- MSCR (AASHTO T350) @ 64 JnR3.2 < 0.50

As a minimum the sealant will meet PG 64E-28 requirements after modification. The asphalt supplier shall provide testing results for both the neat and modified asphalt binders

Fiber reinforcing materials shall be short-length polyester fibers having the following properties:

Length*	0.25 in. ± 0.02 in.
Elongation at Break (ASTM D2256-90)	35% ± 3%
Melting Point (ASTM D3418-82)	>475°F
Crimps/Inch (ASTM 03937-90)	None
Cross-Section	Round
Denier (ASTM D1577-90)	4.5 Nominal dpf
Tensile Strength (ASTM D2256-90)	>70,000 psi
Diameter	0.0008 in.**
Specific Gravity (ASTM D792-91)	1.32 to 1.40

* At temperatures ranging from ambient to maximum finished product mix temperature

** Subject to normal variations

The modified asphalt-fiber compound shall be mixed with a minimum of 6% and a maximum of 8% fiber (weight to weight) to asphalt cement unless otherwise approved by the Department.

The polymer modified asphalt-fiber compound shall be thoroughly mixed for a minimum of one hour at the required temperature range of 320°F to 375°F before application can begin. To ensure a uniform fiber distribution in the sealant, and also to limit fluctuations in the application temperature of the blended material, the contractor must have a full tanker of sealant mixed, heated to the proper application temperature, and ready for testing at the start of each work day. Once that batch of sealant is emptied from the tanker, crack sealing operations will cease for the remainder of the day.

No new material will be allowed to be added to the tanker during the workday under any circumstances. Bulk tankers shall be filled at the approved asphalt supplier's facility, and accompanied by a bill of lading, material data sheet, and total pounds of material loaded.

A Manufacturer's certificate of material compliance will be furnished to the Department certifying conformance to the above material specifications, including the following:

- Performance Grade of Unmodified Asphalt: PG 58-28 (standard) AASHTO M-320, Table 1
- 7% chemically-modified crumb rubber (CMCR) Composed of 100% 80-mesh recycled tire rubber
- Specially formulated polymer package to include 3-4% polymer
- Performance Grade of Modified Asphalt: PG 64E-28
- A minimum of 6%, and maximum of 8% polyester reinforcing fibers

Blending of the fibers with the modified asphalt binder shall be in accordance with the recommendations of the manufacturer of the fibers and supplier of the polymer modified asphalt, with final approval made by the Department.

The contractor shall provide the Resident or authorized representative with a copy of the material manufacturer's recommendations for the sealant material being provided pertaining to heating, mixing, application, and reheating prior to the beginning of operations, or the changing of materials.

Material Temperatures Minimum polymer modified asphalt-fiber sealant application temperature shall be 320°F and not exceed 375°F.

QUALITY CONTROL REQUIREMENTS

Quality Control The Contractor shall develop and submit a Quality Control Plan (QCP) that addresses the materials to be used, equipment to be used, methods of material usage (quantity measurements and tracking) as well as installation methods and protection of the work as it is completed. The Contractor shall control the work and operate in accordance with the approved QCP in order to install product and complete work meeting the contract requirements. The Contractor shall not begin sealing operations until the Department approves the QCP in writing.

Quality Control The QCP shall meet the requirements of Section 106.6 – Acceptance and this Section. The QCP shall address any items that affect the quality of the operation, and shall include the following personnel meeting these minimum requirements:

- a. QCP Administrator – The QCP Administrator must be a full-time employee of or a consultant engaged by the prime contractor or crack sealing subcontractor. The QCP Administrator shall have full authority to institute any and all actions necessary for the successful implementation of the QCP. The QCP Administrator (or their designee in the QCP Administrator’s absence) may not be required to be onsite during all work activities but shall be available to communicate with the Department as needed.
- b. Onsite Representative - The Onsite Representative (OR) shall be onsite and work directly with the crew as needed. The OR shall perform quality control inspections or measurements at the job site to assure that materials or installations meet the requirements of the contract.

The QCP shall detail the coordination of the activities of the Plan Administrator, and the OR. The Superintendent shall be named in the QCP if different than the OR, and the responsibilities for successful implementation of the QCP within the companies’ activities shall be outlined.

The QCP shall address any items that may impact the quality of the sealant installation including, but not limited to, the following:

a. General Requirements:

- Name of QCP Administrator
- Description of corrective action processes
- Remediation of defective work

b. Quality Control Plan requirements

- Name of Onsite Representative(s)
- Material type to be used (including product data sheet)
- Heating and installation temperatures
- Procedures to clean, dry and properly prepare all cracks for installation of crack sealants / fillers.
- General sealing operation activities including equipment to be used to install sealants
- Procedures to ensure that cracks are “flush filled” and any overband width does not exceed the contract requirements.
- Procedures to protect any installed sealant from damage from traffic or construction activities.

A summary of the day’s results including a quantity report, equipment used, and environmental conditions will be recorded and signed by the OR and presented to the Department’s representative by 1 PM the following working day.

Failure to adhere to the QCP, replace or repair defective or non-conforming equipment, or adjust material or installation procedures in an effort to produce work that meets the contract requirements will result in a notification of a quality control violation resulting in monetary penalties.

A letter describing the violation shall be provided to the Contractor which will result in a mandatory work suspension and a reduction in payment as shown in Table 106.4A below. The Contractor shall submit a letter to the Department that details the corrective action made to address the violation(s) in its Quality Control Plan. Work may resume when the Department is satisfied the corrective action will result in adherence to the Quality Control Plan.

Table 106.4 A - Quality Control Pay Reduction

Quality Control Plan Value*		Pay Reduction		
From More Than	To and Including	1st	2nd	3rd & Subsequent
\$0	\$500,000	\$1,000	\$2,000	\$4,000
\$500,000	\$1,000,000	\$2,000	\$4,000	\$8,000
\$1,000,000	\$3,000,000	\$5,000	\$10,000	\$20,000
\$3,000,000	and more	\$10,000	\$20,000	\$40,000

* The Quality Control Plan Value is the total Bid value of all items covered by a Quality Control Plan, as detailed in the applicable specification or Special Provision.

Pay reductions for failure to comply with the approved QCP are cumulative, and the Department will deduct any pay reductions from amounts otherwise due the Contractor. These pay reductions are intended to encourage the Contractor to comply with its approved QCP, and are not necessarily related to the quality of the work provided.

EQUIPMENT

Equipment used in the performance of the work shall be subject to the Resident’s or authorized representative’s approval and shall be maintained in a satisfactory working condition at all times. As a minimum, the equipment required will consist of the following:

- (1) Air Compressor and air wand A portable air compressor and air wand shall be supplied to clean the cracks to be sealed prior to using a hot air lance. The air compressor shall be coupled with hose and air wand and be capable of furnishing not less than 150 CFM of air at not less than 100 psi pressure through a 5/8”- inch diameter nozzle. A ½ -inch or ¾-inch nozzle may be used with approval of the Inspector as long as the pressure requirements are being met. The compressor shall be equipped with traps that will maintain the compressed air free of oil and water. A single air compressor may be utilized to supply air to both the air wand and hot air lance with the condition that it will consistently supply the required air volume and pressures for each operation simultaneously.
- (2) Sweeper Manually operated, gas powered air-broom or self-propelled sweeper designed especially for use in cleaning highway and airfield pavements shall be used to remove debris, dirt and dust from the cracks.

(3) Hot Air Lance The hot air lance shall be independent of the air wand unit. The hot air lance shall be operated with propane and compressed air in combination and provide 1000 ft/sec of heated air at 2000°F - 3000°F, at not less than 120 psi. The lance should draw propane from no smaller than a 100 lb. tank using separate hoses for propane and air draw. The hoses shall be wrapped together with reflectorized wrap to keep them together and to protect workers in low light situations. A single air compressor may be utilized to supply air to both the air wand and hot air lance with the condition that it will consistently supply the required air volume and pressures for each operation simultaneously.

(4) Application Wand The application wand shall apply a controlled flow of material via an insulated or heated hose. The nozzle shall distribute the material as called for in this specification. A pressure regulator shall be provided to regulate pressure at the nozzle. Sealant shall be installed using a nozzle for flush filled applications, or a small to medium application disc for overband permitted installations selected to give a narrow overband over the cracks being sealed and minimize final overband thickness above the pavement surface.

(5) Hand Tools Hand tools shall consist of shall consist of brooms, shovels, metal bars with chisel shaped ends, and any other tools which may be satisfactorily used to prepare cracks to be sealed. Other tools such as, but not limited to, V-shaped squeegee or flat squeegee may be necessary to prevent excessive overband width and thickness.

(6) Melter: The unit used to melt or maintain the modified asphalt crack sealant compound shall have an approximate capacity of 1,000 gallons and be equipped to maintain the sealant compound at the recommended application temperature. The unit shall be of the indirect fired type, shall be equipped with a remote heat exchanger and hot oil circulation pump capable of maintaining a consistent temperature of the heat transfer oil. The heat transfer oil shall be circulated to all sides and the bottom of the tank containing the crack sealant compound making a continuous loop back to the heat exchanger and having a flash point of not less than 600°F. The melter shall be equipped with a satisfactory means of agitating the crack sealant at all times. This may be accomplished by continuous stirring with mechanically operated paddles and/or by a circulating gear pump attached to the melter. The melter must be equipped with a thermostatic control calibrated between 200°F and 550°F and must be capable of pumping a 6 - 8% fiber content blend.

7) Bulk Tanker: The bulk tanker unit used to heat and maintain the modified asphalt crack sealant compound shall have an approximate capacity of 3,000 to 5,000 gallons and be equipped to maintain the sealant compound at the recommended application temperature.

Documentation shall be provided for each tanker use with verified gallons or pounds of material that each tanker holds. If full tankers are provided on a daily basis, and each tanker is emptied daily, then the verified gallons or pounds each tanker holds may be used for calculation of payment.

If partial loads are supplied, or material remains in the tanker at the end of the day or contract, a means to calculated material usage must be provided in the form of either calibrated tank checks corrected to 60°F, or certified scale weights of the material load at the beginning or end of the day as applicable.

GENERAL CONSTRUCTION REQUIREMENTS

Weather Crack Sealant Material shall not be applied on a wet surface, when the atmospheric temperature is below 50°F in a shaded area at the job site, or when weather conditions are otherwise unfavorable to proper construction procedures.

Equipment Equipment used in the performance of the work shall meet the requirements of the material and equipment section of this special provision and approved by the Department. Equipment shall be maintained in a satisfactory working condition at all times.

Preparation All cracks to be sealed shall be blown free of loose material, dirt, vegetation, and other debris by the high pressure air wand. Material removed from the crack shall be removed from the pavement surface by means of a power sweeper or appropriate hand tools as required. Cracks showing evidence of vegetation after being blown out shall be additionally cleaned by appropriate hand tools and additionally blown out. All cracks must be blown clean with the high-pressure air wand in advance of the hot air lance. All cracks shall be heated via the hot air lance a maximum of 5 minutes prior to the crack sealant being applied. Distance between the hot air lance and the crack sealing unit should be no more than 50 ft to eliminate reinvasion of water, debris, and other incompressible material. All debris, vegetation, and water shall be removed to enhance adhesion of the crack sealing material. THIS WORK SHALL NOT BE DONE IN INCLEMENT WEATHER.

Preparation and Placement of Sealer The polymer modified asphalt-fiber material shall be heated, mixed and applied at the temperature specified by the manufacturer and approved by the Resident or authorized representative. The polymer modified asphalt-fiber compound shall be thoroughly mixed for a minimum of one hour before application can begin. Any material that has been heated above the manufacturer's specification shall not be used, and approval of the Resident or authorized representative. The Contractor shall provide the Resident or authorized representative with a suitable device for verifying the sealant temperature in the kettle and at the application site. Any over application or spills are to be removed to the satisfaction of the Resident or authorized representative. Any sealed areas with damaged or contaminated sealer or visible voids are to be removed, prepared and resealed at no additional cost to the Department.

Sealer shall be delivered to the crack while cracks are still hot from the hot air lance preparation through a pressure hose line, applicator nozzle or applicator shoe depending on crack filling requirements.

For projects where sealants will be covered and a hot mix asphalt overlay is being installed over the sealant all cracks will be “**flush filled**”, meaning cracks are filled to a point that the sealant is flush with the existing pavement surface. If the work scope requires a flush fill a nozzle sized to fill the cracks shall be used. Minimal to no overbanding will be permitted. The applicator shoe width shall be a maximum of 2 inch internal disc dimension and produce a sealer width range from 1 inch – 1.5 inch. Overall width of the sealant may vary from the range specified depending on the width and severity of the cracks with approval from the Department.

For projects where the sealants are left un-covered with a hot mix overlay and traffic will be permitted to travel over the sealants for the anticipated sealant life, some overband may be permitted. If the work scope required crack filling and sealing with overband, then a shoe sized to meet the overband width shall be used. The applicator shoe width shall be a maximum of 2 inch internal dimension and produce a sealer overband range from 1 inch – 1.5 inch. Overbanding width may vary from the range specified depending on the width and severity of the cracks with approval from the Department.

Generally, overband will be kept to a minimum and not exceed a maximum of 1 1/2-inch-wide and 3/32 inch thick. The applicator may be followed by a squeegee to minimize the thickness of the overband.

Any loose material on the surface or in the crack which may contaminate the crack sealer or impede bonding of the sealant to the pavement, is to be removed by hand tools prior to crack filling. No crack filling material shall be applied in a crack that is wet or where frost, snow, or ice is present.

Minimum polymer modified asphalt-fiber sealant application temperature shall be 320°F and not exceed 375°F.

If the sealed area is to be opened to traffic immediately, a barrier material (de-tackifier) such as Glenzoil, Black Beauty grit, or an equivalent product approved by the Resident shall be provided by the Contractor be applied to the crack sealer to prevent pickup as directed by the Resident or authorized representative.

If the sealed areas are to be paved over with a hot mix treatment, then a 48-hour minimum cure time and use of barrier material (de-tackifier) will be required. Cure times may be extended if excessive pick-up of the crack sealants occurs.

Quality of Work Excess of spilled sealer shall be removed from the pavement by approved methods and discarded. Any quality of work determined to be below normal acceptable standards will not be accepted, and will be corrected and/or replaced as directed by the Resident or authorized representative at no additional cost to the Department.

Method of Measurement Polymer modified asphalt-fiber sealant will be measured by the pound of sealant used. The manufacturer's weight per tanker of sealant will be accepted as the basis for measurement. Materials supplied by weight will be accompanied by a bill of lading and material certification.

The Department may, at their discretion, verify the manufacturers weights provided by re-weighing the tankers at independent scale facilities.

The Department may, on a case-by-case basis, approve and perform tank checks to measure the sealant by the gallon and convert to pounds.

Should tank checks be approved to verify material usage or calculate initial or final gallons remaining in the tanker, a calibrated tank gauge or tank stick shall be used to measure the tank gallons. Volume corrections shall be calculated using Table:1 to correct the gallon volume to 60 ° F.

For those approved cases the Department has determined the weight of this material to be 8.37 pounds per gallon. The Department will use this conversion value for all materials measured by the gallon and converted to pounds.

Basis of Payment The accepted quantity of polymer modified asphalt-fiber sealant will be paid for at the contract unit price per pound for the item listed in the contract schedule of items, complete in place. This price shall be full compensation for furnishing and placing crack sealer, including cleaning cracks, heating and drying cracks, all labor, and furnishing and placing barrier or blotter materials as necessary.

Conversion Table:1

t	M	t	M	t	M	t	M	t	M	t	M
100	0.9861	135	0.9740	170	0.9621	205	0.9503	240	0.9385	275	0.9269
101	0.9857	136	0.9737	171	0.9618	206	0.9499	241	0.9382	276	0.9266
102	0.9854	137	0.9734	172	0.9614	207	0.9496	242	0.9379	277	0.9263
103	0.9851	138	0.9730	173	0.9611	208	0.9493	243	0.9375	278	0.9259
104	0.9847	139	0.9727	174	0.9607	209	0.9489	244	0.9372	279	0.9256
105	0.9844	140	0.9723	175	0.9604	210	0.9486	245	0.9369	280	0.9253
106	0.9840	141	0.9720	176	0.9601	211	0.9483	246	0.9365	281	0.9250
107	0.9837	142	0.9716	177	0.9597	212	0.9479	247	0.9362	282	0.9246
108	0.9833	143	0.9713	178	0.9594	213	0.9476	248	0.9359	283	0.9243
109	0.9830	144	0.9710	179	0.9590	214	0.9472	249	0.9356	284	0.9240
110	0.9826	145	0.9706	180	0.9587	215	0.9469	250	0.9352	285	0.9236
111	0.9823	146	0.9703	181	0.9584	216	0.9466	251	0.9349	286	0.9233
112	0.9819	147	0.9699	182	0.9580	217	0.9462	252	0.9346	287	0.9230
113	0.9816	148	0.9696	183	0.9577	218	0.9459	253	0.9342	288	0.9227
114	0.9813	149	0.9693	184	0.9574	219	0.9456	254	0.9339	289	0.9223
115	0.9809	150	0.9689	185	0.9570	220	0.9452	255	0.9336	290	0.9220
116	0.9806	151	0.9686	186	0.9567	221	0.9449	256	0.9332	291	0.9217
117	0.9802	152	0.9682	187	0.9563	222	0.9446	257	0.9329	292	0.9213
118	0.9799	153	0.9679	188	0.9560	223	0.9442	258	0.9326	293	0.9210
119	0.9795	154	0.9675	189	0.9557	224	0.9439	259	0.9322	294	0.9207
120	0.9792	155	0.9672	190	0.9553	225	0.9436	260	0.9319	295	0.9204
121	0.9788	156	0.9669	191	0.9550	226	0.9432	261	0.9316	296	0.9200
122	0.9785	157	0.9665	192	0.9547	227	0.9429	262	0.9312	297	0.9197
123	0.9782	158	0.9662	193	0.9543	228	0.9426	263	0.9309	298	0.9194
124	0.9778	159	0.9658	194	0.9540	229	0.9422	264	0.9306	299	0.9190
125	0.9775	160	0.9655	195	0.9536	230	0.9419	265	0.9302	300	0.9187
126	0.9771	161	0.9652	196	0.9533	231	0.9416	266	0.9299	301	0.9184
127	0.9768	162	0.9648	197	0.9530	232	0.9412	267	0.9296	302	0.9181
128	0.9764	163	0.9645	198	0.9526	233	0.9409	268	0.9293	303	0.9177
129	0.9761	164	0.9641	199	0.9523	234	0.9405	269	0.9289	304	0.9174
130	0.9758	165	0.9638	200	0.9520	235	0.9402	270	0.9286	305	0.9171
131	0.9754	166	0.9635	201	0.9516	236	0.9399	271	0.9283	306	0.9167
132	0.9751	167	0.9631	202	0.9513	237	0.9395	272	0.9279	307	0.9164
133	0.9747	168	0.9628	203	0.9509	238	0.9392	273	0.9276	308	0.9161
134	0.9744	169	0.9624	204	0.9505	239	0.9389	274	0.9273	309	0.9158

Legend: t = observed temperature in degrees Fahrenheit.
M = multiplier for reducing volumes to the basis of 60° F.

Conversion Table:1

t	M	t	M	t	M	t	M	t	M
310	0.9154	350	0.9024	390	0.8896	430	0.8768	470	0.8643
311	0.9151	351	0.9021	391	0.8892	431	0.8765	471	0.8640
312	0.9148	352	0.9018	392	0.8889	432	0.8762	472	0.8636
313	0.9145	353	0.9015	393	0.8886	433	0.8759	473	0.8633
314	0.9141	354	0.9011	394	0.8883	434	0.8756	474	0.8630
315	0.9138	355	0.9008	395	0.8880	435	0.8753	475	0.8627
316	0.9135	356	0.9005	396	0.8876	436	0.8749	476	0.8624
317	0.9132	357	0.9002	397	0.8873	437	0.8746	477	0.8621
318	0.9128	358	0.8998	398	0.8870	438	0.8743	478	0.8618
319	0.9125	359	0.8995	399	0.8867	439	0.8740	479	0.8615
320	0.9122	360	0.8992	400	0.8864	440	0.8737	480	0.8611
321	0.9118	361	0.8989	401	0.8861	441	0.8734	481	0.8608
322	0.9115	362	0.8986	402	0.8857	442	0.8731	482	0.8605
323	0.9112	363	0.8982	403	0.8854	443	0.8727	483	0.8602
324	0.9109	364	0.8979	404	0.8851	444	0.8724	484	0.8599
325	0.9105	365	0.8976	405	0.8848	445	0.8721	485	0.8596
326	0.9102	366	0.8973	406	0.8845	446	0.8718	486	0.8593
327	0.9099	367	0.8969	407	0.8841	447	0.8715	487	0.8590
328	0.9096	368	0.8966	408	0.8838	448	0.8712	488	0.8587
329	0.9092	369	0.8963	409	0.8835	449	0.8709	489	0.8583
330	0.9089	370	0.8960	410	0.8832	450	0.8705	490	0.8580
331	0.9086	371	0.8957	411	0.8829	451	0.8702	491	0.8577
332	0.9083	372	0.8953	412	0.8826	452	0.8699	492	0.8574
333	0.9079	373	0.8950	413	0.8822	453	0.8696	493	0.8571
334	0.9076	374	0.8947	414	0.8819	454	0.8693	494	0.8568
335	0.9073	375	0.8944	415	0.8816	455	0.8690	495	0.8565
336	0.9070	376	0.8941	416	0.8813	456	0.8687	496	0.8562
337	0.9066	377	0.8937	417	0.8810	457	0.8683	497	0.8559
338	0.9063	378	0.8934	418	0.8806	458	0.8680	498	0.8556
339	0.9060	379	0.8931	419	0.8803	459	0.8677	499	0.8552
340	0.9057	380	0.8928	420	0.8800	460	0.8674		
341	0.9053	381	0.8924	421	0.8797	461	0.8671		
342	0.9050	382	0.8921	422	0.8794	462	0.8668		
343	0.9047	383	0.8918	423	0.8791	463	0.8665		
344	0.9044	384	0.8915	424	0.8989	464	0.8661		
345	0.9040	385	0.8912	425	0.8984	465	0.8658		
346	0.9037	386	0.8908	426	0.8781	466	0.8655		
347	0.9034	387	0.8905	427	0.8778	467	0.8652		
348	0.9031	388	0.8902	428	0.8775	468	0.8649		
349	0.9028	389	0.8899	429	0.8772	469	0.8646		

Legend: t = observed temperature in degrees Fahrenheit.
M = multiplier for reducing volumes to the basis of 60° F.

SPECIAL PROVISION
SECTION 424
CRACK REPAIR with HOT POUR MASTIC

Description This work shall consist of preparing and repairing areas identified for crack repair in existing bituminous or concrete pavement layers using hot pour mastic. The hot pour mastic shall be supplied in solid form in boxes containing pre-measured binder blended with aggregates. Products to be used will be subject to approval by the Department. Repair areas will be free of sand, vegetation, water, and any previously placed rubber crack seal or crack repair materials, including cold patch. Preparation, such as cleaning and drying of the cracks by use of oil free compressed air and hot air lance shall be considered included the price per pound of crack repair mastic. Any pavement removal required will be paid for under the appropriate item as described in this Special Provision.

MATERIALS

The hot pour mastic materials are hot-applied, pourable, self-adhesive mastics blended with aggregates designed for maintenance and repair of asphalt and Portland cement concrete pavements. The hot pour mastic materials are composed of highly modified polymer asphalt binder and standard weight aggregates as required by the application.

The mastic materials shall be delivered in the manufacturer’s original container. The material shall be pre-packaged with the manufacturers name and product name marked on each container. The materials shall conform to the following requirements:

<u>Parameter</u>	
Color	Black
Pourability @ 400F (PTM1)*	1000-1400 gm
Stability @ 158F (PTM2)	.6in. max
Flexibility @ Low Temperature (PTM3)	Pass @ -20F
Adhesion @77F (PTM4)	15psi min.
Specific Gravity (ASTM D792)	1.35max.
Skid Resistance, BPN (ASTM E303)	40 min.
Minimum Application Temperature	375°F
Maximum Application Temperature	410°F

QUALITY CONTROL REQUIREMENTS

Quality Control The Contractor shall develop and submit a Quality Control Plan (QCP) that addresses the materials to be used, equipment to be used, methods of material usage (quantity measurements and tracking) as well as installation methods and protection of the work as it is completed. The Contractor shall control the work and operate in accordance with the approved QCP in order to install product and complete work meeting the contract requirements. The Contractor shall not begin sealing operations until the Department approves the QCP in writing.

Quality Control The QCP shall meet the requirements of Section 106.6 – Acceptance and this Section. The QCP shall address any items that affect the quality of the operation, and shall include the following personnel meeting these minimum requirements:

- a. QCP Administrator – The QCP Administrator must be a full-time employee of or a consultant engaged by the prime contractor or crack sealing subcontractor. The QCP Administrator shall have full authority to institute any and all actions necessary for the successful implementation of the QCP. The QCP Administrator (or their designee in the QCP Administrator’s absence) may not be required to be onsite during all work activities but shall be available to communicate with the Department as needed.
- b. Onsite Representative - The Onsite Representative (OR) shall be onsite and work directly with the crew as needed. The OR shall perform quality control inspections or measurements at the job site to assure that materials or installations meet the requirements of the contract.

The QCP shall detail the coordination of the activities of the Plan Administrator, and the OR. The Superintendent shall be named in the QCP if different than the OR, and the responsibilities for successful implementation of the QCP within the companies’ activities shall be outlined.

The QCP shall address any items that may impact the quality of the sealant installation including, but not limited to, the following:

a. General Requirements:

- Name of QCP Administrator
- Description of corrective action processes
- Remediation of defective work

b. Quality Control Plan requirements

- Name of Onsite Representative(s)
- Material type to be used (including product data sheet)
- Heating and installation temperatures
- Procedures to clean, dry and properly prepare all cracks for installation of crack sealants / fillers.
- General sealing operation activities including equipment to be used to install sealants
- Procedures to ensure that cracks are “flush filled” and any overband width does not exceed the contract requirements.
- Procedures to protect any installed sealant from damage from traffic or construction activities.

A summary of the day’s results including a quantity report, equipment used, and environmental conditions will be recorded and signed by the OR and presented to the Department’s representative by 1 PM the following working day.

Failure to adhere to the QCP, replace or repair defective or non-conforming equipment, or adjust material or installation procedures in an effort to produce work that meets the contract requirements will result in a notification of a quality control violation resulting in monetary penalties.

A letter describing the violation shall be provided to the Contractor which will result in a mandatory work suspension and a reduction in payment as shown in Table 106.4A below. The Contractor shall submit a letter to the Department that details the corrective action made to address the violation(s) in its Quality Control Plan. Work may resume when the Department is satisfied the corrective action will result in adherence to the Quality Control Plan.

Table 106.4 A - Quality Control Pay Reduction

Quality Control Plan Value*		Pay Reduction		
From More Than	To and Including	1st	2nd	3rd & Subsequent
\$0	\$500,000	\$1,000	\$2,000	\$4,000
\$500,000	\$1,000,000	\$2,000	\$4,000	\$8,000
\$1,000,000	\$3,000,000	\$5,000	\$10,000	\$20,000
\$3,000,000	and more	\$10,000	\$20,000	\$40,000

* The Quality Control Plan Value is the total Bid value of all items covered by a Quality Control Plan, as detailed in the applicable specification or Special Provision.

Pay reductions for failure to comply with the approved QCP are cumulative, and the Department will deduct any pay reductions from amounts otherwise due the Contractor. These pay reductions are intended to encourage the Contractor to comply with its approved QCP, and are not necessarily related to the quality of the work provided.

EQUIPMENT

Equipment Equipment used in the performance of the work shall be subject to the Departments or authorized representative’s approval and shall be maintained in a satisfactory working condition at all times.

(a) Air Compressor Air compressors shall be portable and capable of furnishing not less than 4 yd³ of air per minute at not less than 90 psi pressure at the nozzle. The compressor shall be equipped with traps that will maintain the compressed air free of oil and water.

(b) Sweeper Manually operated, gas powered air-broom or self-propelled sweeper designed especially for use in cleaning pavements shall be used to remove debris, dirt, and dust from the cracks.

(c) Hot Air Lance Should operate with propane and compressed air in combination at 2000°F - 3000°F, exit air heated at 1000 ft/s. The lance should draw propane from no smaller than a 100 lb tank using separate hoses for propane and air draw. The hoses shall be wrapped together with reflectorized wrap to keep them together and to protect workers in low light situations.

(d) Hand Tools Shall consist of Boxed or V-shaped squeegee, brooms, shovels, metal bars with chisel shaped ends, and any other tools which may be satisfactorily used to accomplish this work.

(e) Melting Kettle The unit used to heat the mastics shall be a double boiler unit equipped with continuous horizontal full sweep agitation and have separate thermostatic control devices that will automatically regulate hot oil and material temperature. Separate digital readouts shall display the temperatures of the hot oil and material. The kettle shall be equipped with mixing paddles, blending augers, or other satisfactory means of agitating, mixing, and blending the aggregates and mastic together. The kettle must be equipped with thermostatic control calibrated between 200°F and 550°F.

If required in the contract the router or crack saw equipment for preparing cracks shall be of a rotary impact type cutter, equipped with a carbide bit or a diamond-blade crack saw which will provide a reservoir of specified dimensions.

CONSTRUCTION REQUIREMENTS

Weather Hot Pour Mastics shall not be applied on a wet or damp surface, or when the atmospheric temperature is below 45°F in a shaded area at the job site, or when weather conditions are otherwise unfavorable to proper crack repair procedures.

Preparation All cracks shall be prepared to receive the mastic material. All cracks must be cleaned of debris, dried and heated to ensure optimal bonding of the sealant material to the existing pavement and crack edges. All cracks shall be flush filled with pre-blended mastic with minimal overband in the same workday as directed by the Resident or authorized representative.

Cracks greater than 1 inch in width shall be thoroughly cleaned by use of compressed air and dried by use of a hot air lance. Any loose or broken materials will be removed from the repair area before placing mastic materials. If it is determined that additional pavement removal or preparation is needed by means of milling, sawing, or cutting of existing pavement the work will be paid under an appropriate pay item. All materials routed, sawn, cut, or otherwise removed from the areas to be repaired shall immediately be removed from the crack and surrounding paved area by use of compressed air sweeping, or combination of both.

Cracks 1 inch in width to 6 inch width, or repairs that are more structural in nature, such as potholes, depressions, fills or repairs around utility adjustments shall be filled with mastic pre-blended with standard weight aggregates. Generally repairs wider than 6 inches, or those that extend below the surface layer may require additional pavement removal or change in crack treatment type.

All mastic materials shall be heated to between 380°F and 410°F and thoroughly agitated prior to application. A non-contact infrared thermometer shall be used periodically to monitor the temperature of the material as it exits the kettle. Material may not be used if it is heated beyond the safe heating temperature of 410°F, exceeds the recommended pot life, or is reheated more than one time.

Mastics may be applied to large or excessive slope repair areas when the material has been heated to the lower end of the temperature range, or with the addition of 1% of an approved synthetic fiber to minimize material flow and cooling time.

Mastics shall be applied to the repair areas directly from the melting kettle chute, wand or other conveyance method filled from the kettle. If bucketed, material cooling during transfer must be minimized.

The repair area shall be filled flush to the pavement surface. The material shall be poured into the repair area and worked using boxed or v-shaped squeegees, tools, lutes or heated irons. Care should be taken not to over work the material and cause unequal dispersion of the aggregate within the repair. The material may be applied in multiple lifts to accommodate material shrinkage or flow during cooling.

After materials have been applied to the repair, indirect heating by torch or hot air lance can be used to heat the edges and ensure a watertight seal. Do not burn, scorch or ignite the mastic or adjoining pavement when heating.

Do not allow traffic on the repaired areas for one ½ hour, or until the material has cooled enough to support traffic and tracking is minimal.

Quality of Work Excess mastic shall be removed from the pavement by approved methods and discarded. Any work determined to be below normal acceptable standards will not be accepted, and will be corrected and/or replaced as directed by the Resident or authorized representative.

Method of Measurement Crack Repair with Hot Pour Mastic will be measured by the pound of mastic used. The manufacturer's weights of the mastic for each block (pill), counted as they are loaded, will be accepted as a basis for measurement.

Should tank checks be approved to verify material usage or calculate initial or final gallons remaining in the kettle, a calibrated kettle gauge or tank stick shall be used to measure the kettle gallons. Volume corrections shall be calculated using Table:1 to correct the gallon volume to 60 ° F.

For those approved cases the Department has determined the weight of this material to be 15.5 pounds per gallon. The Department will use this conversion value for all materials measured by the gallon and converted to pounds. The corrected volume and resultant pounds shall be made part of the method of measurement, with consideration given to blocks (pills) added during the day and applied in an acceptable manner

Basis of Payment The accepted quantity of Crack Repair with Hot Pour Mastic will be paid for at the contract unit price per pound. This price will be full compensation for furnishing the appropriate material type for the repair being done, heating, placing and finishing the mastic materials, as well as cleaning and preparing the areas for installation of the mastic, including the use of compressed air, hot air lance, and any sweeping required to remove contaminants from and dry the areas to be treated. Areas identified as requiring pavement removal by means of cutting, sawing, grinding, or routing will be paid under an appropriate contract item.

Payment will be made under:

<u>Pay Item</u>	<u>Pay Unit</u>
424.38 Crack Repair, Hot Pour Mastic	Pound

Conversion Table:1

t	M	t	M	t	M	t	M	t	M	t	M
100	0.9861	135	0.9740	170	0.9621	205	0.9503	240	0.9385	275	0.9269
101	0.9857	136	0.9737	171	0.9618	206	0.9499	241	0.9382	276	0.9266
102	0.9854	137	0.9734	172	0.9614	207	0.9496	242	0.9379	277	0.9263
103	0.9851	138	0.9730	173	0.9611	208	0.9493	243	0.9375	278	0.9259
104	0.9847	139	0.9727	174	0.9607	209	0.9489	244	0.9372	279	0.9256
105	0.9844	140	0.9723	175	0.9604	210	0.9486	245	0.9369	280	0.9253
106	0.9840	141	0.9720	176	0.9601	211	0.9483	246	0.9365	281	0.9250
107	0.9837	142	0.9716	177	0.9597	212	0.9479	247	0.9362	282	0.9246
108	0.9833	143	0.9713	178	0.9594	213	0.9476	248	0.9359	283	0.9243
109	0.9830	144	0.9710	179	0.9590	214	0.9472	249	0.9356	284	0.9240
110	0.9826	145	0.9706	180	0.9587	215	0.9469	250	0.9352	285	0.9236
111	0.9823	146	0.9703	181	0.9584	216	0.9466	251	0.9349	286	0.9233
112	0.9819	147	0.9699	182	0.9580	217	0.9462	252	0.9346	287	0.9230
113	0.9816	148	0.9696	183	0.9577	218	0.9459	253	0.9342	288	0.9227
114	0.9813	149	0.9693	184	0.9574	219	0.9456	254	0.9339	289	0.9223
115	0.9809	150	0.9689	185	0.9570	220	0.9452	255	0.9336	290	0.9220
116	0.9806	151	0.9686	186	0.9567	221	0.9449	256	0.9332	291	0.9217
117	0.9802	152	0.9682	187	0.9563	222	0.9446	257	0.9329	292	0.9213
118	0.9799	153	0.9679	188	0.9560	223	0.9442	258	0.9326	293	0.9210
119	0.9795	154	0.9675	189	0.9557	224	0.9439	259	0.9322	294	0.9207
120	0.9792	155	0.9672	190	0.9553	225	0.9436	260	0.9319	295	0.9204
121	0.9788	156	0.9669	191	0.9550	226	0.9432	261	0.9316	296	0.9200
122	0.9785	157	0.9665	192	0.9547	227	0.9429	262	0.9312	297	0.9197
123	0.9782	158	0.9662	193	0.9543	228	0.9426	263	0.9309	298	0.9194
124	0.9778	159	0.9658	194	0.9540	229	0.9422	264	0.9306	299	0.9190
125	0.9775	160	0.9655	195	0.9536	230	0.9419	265	0.9302	300	0.9187
126	0.9771	161	0.9652	196	0.9533	231	0.9416	266	0.9299	301	0.9184
127	0.9768	162	0.9648	197	0.9530	232	0.9412	267	0.9296	302	0.9181
128	0.9764	163	0.9645	198	0.9526	233	0.9409	268	0.9293	303	0.9177
129	0.9761	164	0.9641	199	0.9523	234	0.9405	269	0.9289	304	0.9174
130	0.9758	165	0.9638	200	0.9520	235	0.9402	270	0.9286	305	0.9171
131	0.9754	166	0.9635	201	0.9516	236	0.9399	271	0.9283	306	0.9167
132	0.9751	167	0.9631	202	0.9513	237	0.9395	272	0.9279	307	0.9164
133	0.9747	168	0.9628	203	0.9509	238	0.9392	273	0.9276	308	0.9161
134	0.9744	169	0.9624	204	0.9505	239	0.9389	274	0.9273	309	0.9158

Legend: t = observed temperature in degrees Fahrenheit.
M = multiplier for reducing volumes to the basis of 60° F.

Conversion Table:1

t	M	t	M	t	M	t	M	t	M
310	0.9154	350	0.9024	390	0.8896	430	0.8768	470	0.8643
311	0.9151	351	0.9021	391	0.8892	431	0.8765	471	0.8640
312	0.9148	352	0.9018	392	0.8889	432	0.8762	472	0.8636
313	0.9145	353	0.9015	393	0.8886	433	0.8759	473	0.8633
314	0.9141	354	0.9011	394	0.8883	434	0.8756	474	0.8630
315	0.9138	355	0.9008	395	0.8880	435	0.8753	475	0.8627
316	0.9135	356	0.9005	396	0.8876	436	0.8749	476	0.8624
317	0.9132	357	0.9002	397	0.8873	437	0.8746	477	0.8621
318	0.9128	358	0.8998	398	0.8870	438	0.8743	478	0.8618
319	0.9125	359	0.8995	399	0.8867	439	0.8740	479	0.8615
320	0.9122	360	0.8992	400	0.8864	440	0.8737	480	0.8611
321	0.9118	361	0.8989	401	0.8861	441	0.8734	481	0.8608
322	0.9115	362	0.8986	402	0.8857	442	0.8731	482	0.8605
323	0.9112	363	0.8982	403	0.8854	443	0.8727	483	0.8602
324	0.9109	364	0.8979	404	0.8851	444	0.8724	484	0.8599
325	0.9105	365	0.8976	405	0.8848	445	0.8721	485	0.8596
326	0.9102	366	0.8973	406	0.8845	446	0.8718	486	0.8593
327	0.9099	367	0.8969	407	0.8841	447	0.8715	487	0.8590
328	0.9096	368	0.8966	408	0.8838	448	0.8712	488	0.8587
329	0.9092	369	0.8963	409	0.8835	449	0.8709	489	0.8583
330	0.9089	370	0.8960	410	0.8832	450	0.8705	490	0.8580
331	0.9086	371	0.8957	411	0.8829	451	0.8702	491	0.8577
332	0.9083	372	0.8953	412	0.8826	452	0.8699	492	0.8574
333	0.9079	373	0.8950	413	0.8822	453	0.8696	493	0.8571
334	0.9076	374	0.8947	414	0.8819	454	0.8693	494	0.8568
335	0.9073	375	0.8944	415	0.8816	455	0.8690	495	0.8565
336	0.9070	376	0.8941	416	0.8813	456	0.8687	496	0.8562
337	0.9066	377	0.8937	417	0.8810	457	0.8683	497	0.8559
338	0.9063	378	0.8934	418	0.8806	458	0.8680	498	0.8556
339	0.9060	379	0.8931	419	0.8803	459	0.8677	499	0.8552
340	0.9057	380	0.8928	420	0.8800	460	0.8674		
341	0.9053	381	0.8924	421	0.8797	461	0.8671		
342	0.9050	382	0.8921	422	0.8794	462	0.8668		
343	0.9047	383	0.8918	423	0.8791	463	0.8665		
344	0.9044	384	0.8915	424	0.8989	464	0.8661		
345	0.9040	385	0.8912	425	0.8984	465	0.8658		
346	0.9037	386	0.8908	426	0.8781	466	0.8655		
347	0.9034	387	0.8905	427	0.8778	467	0.8652		
348	0.9031	388	0.8902	428	0.8775	468	0.8649		
349	0.9028	389	0.8899	429	0.8772	469	0.8646		

Legend: t = observed temperature in degrees Fahrenheit.
M = multiplier for reducing volumes to the basis of 60° F.

SPECIAL PROVISION
SECTION 502
STRUCTURAL CONCRETE
(Roadway Truck Apron)

Section 502 – Structural Concrete is amended by the addition of the following:

502.01 Description This work shall consist of furnishing and placing Portland Cement Concrete pavement and incidental construction for the truck apron, as shown on the plans and as directed by the Resident. Except as otherwise specified in this Special Provision, all work shall be in conformity with the applicable provisions of Section 502, Structural Concrete; Section 503, Reinforcing Steel; and Section 515, Protective Coating for Concrete Surfaces.

502.03 Materials

Reinforcement Reinforcement shall be Steel Welded Wire Fabric, Deformed, conforming to Section 503 and Section 709.02 and as noted in the plans.

Preformed Expansion Joint Filler shall meet the requirements of Section 705.01.

502.04 Construction Requirements

Preparation of Foundation The existing material shall be removed to the depth shown on the plans. The foundation bed shall be well graded and compacted, as directed by the Resident, and additional gravel shall be placed to provide the thickness of concrete indicated on the plans.

Prior to the concrete placement, the foundation bed shall be thoroughly and uniformly saturated with water. The bed shall be free of puddles and excessive surface water.

Placement of Concrete Concrete shall be placed in a continuous placement operation between preformed expansion joints. No construction joints will be allowed. Expansion joints shall have an approved expansion joint sealer installed as detailed on the plans. Preformed expansion joints shall be continuous and of an approved material, and control joints shall be sawcut into the surface of the concrete. Expansion joints and control joints shall be placed as shown on the details.

The surface of the concrete shall receive a float finish in accordance with Subsection 502.14(A). Immediately following the float finish, the surface shall be textured at right angles to the roadway using an approved open-pile, stiff bristle broom or mat.

The curing period for the concrete shall be seven days and shall meet the requirements of Standard Specifications Section 502.15. The finished surface of the concrete shall receive a protective coating in accordance with Section 515.

502.18 Method of Measurement Structural Concrete Roadway Truck Apron, satisfactorily placed and accepted, will be measured for payment by the cubic yard, in accordance with the dimensions shown on the plans or authorized by the Resident.

502.19 Basis of Payment The accepted quantity of Structural Concrete Roadway Truck Apron will be paid for at the contract unit price per cubic yard, which payment will be full compensation for all labor, materials, equipment and incidentals necessary to complete the work, including the fabrication, delivery, and placement of reinforcement; the furnishing and placement of expansion and contraction joints and joint sealant; and the furnishing and application of protective coating in accordance with Section 515.

Any grading or shimming of the existing subbase material that may be necessary after pavement removal to provide a suitable foundation for Structural Concrete Roadway Truck Apron shall be incidental. Excavation for the placement of Structural Concrete Roadway Truck Apron will be paid under the appropriate contract item, Section 203 – Excavation and Embankments.

Payment will be made under:

<u>Pay Item</u>		<u>Pay Unit</u>
502.342	Structural Concrete Roadway Truck Apron	Cubic Yard

SPECIAL PROVISION
SECTION 602
PIPE LINING
(Flowable Concrete Fill)

602.01 Description

This work shall consist of providing and placing flowable concrete fill at the locations designated on the Plans.

602.02 Materials

Materials shall conform to the requirements specified in the following Subsections of Division 700 — Materials:

- | | |
|-------------------------------|-----------------------|
| ▪ Portland Cement | 701.01 |
| ▪ Water | 701.02 |
| ▪ Air Entraining Admixtures | 701.03 |
| ▪ Water Reducing Admixtures | 701.04 |
| ▪ Fly Ash | 701.10 |
| ▪ Fine Aggregate for Concrete | 703.01 |
| ▪ Accelerating Admixtures | AASHTO M-194 Type “C” |

602.03 Composition and Proportioning

Flowable concrete fill shall be composed of a homogeneous mixture of Portland Cement and/or pozzolans, fine aggregate, water, and chemical admixtures proportioned according to these Specifications.

The flowable concrete fill shall be proportioned to produce a 28 day compressive strength of 110-500 psi.

The water cement ratio for flowable concrete fill shall not be high enough to cause segregation of the mix.

Air content of five to 15 percent is the target. Higher air contents may be acceptable but will increase set time. All flowable concrete fill shall be air entrained by the addition of an air entraining admixture or other chemical admixtures.

At least 30 days prior to the first placement, a flowable concrete fill mix design shall be submitted by the Contractor to the Resident for approval. No flowable concrete fill shall be placed on the Project until the mix design is approved by the Resident. At a minimum, the mix design submitted by the Contractor shall include the following:

- A. Target water cement ratio
- B. Target strength
- C. Target air content

602.04 Quality Control

Process control measurements of air content, mix temperature, and slump shall be performed on the portion or portions of flowable concrete fill batches delivered to the site. At least one (1) set of measurements for air content, temperature, and slump of flowable concrete fill mix shall be performed per placement or per day, whichever is less frequent. Test cylinders will not be required.

Air content shall be measured following the requirements of AASHTO T152 utilizing Type B equipment.

Slump shall be measured by Modified Slump Test as described below.

Apparatus:

Scoop, measuring tape, flat edge, 3 in. x 6 in. cylinder mold open at both ends, and a flat non-absorbent surface.

Procedure:

1. Set cylinder upright on flat non-absorbent surface.
2. Scoop representative sample of flowable concrete fill.
3. Fill the cylinder, with the sample in one lift without tamping. Strike-off the top with the flat edge to form a level surface.
4. Clear any residue from around the bottom of the cylinder.
5. During a count of three seconds, lift the cylinder straight up allowing the sample to spread on the flat surface.
6. Measure the spread diameter to the nearest 1/2 inch. A spread of nine to 14 inches is considered flowable.

602.05 Batching

Measuring and batching of materials shall be performed at an approved batching plant, either commercial or otherwise.

602.06 Mixing and Delivery

The Contractor shall provide a Certificate of Compliance as described in Standard Specification Section 502, Structural Concrete, Subsection 502.0501, Quality Control METHOD C, for each truckload of flowable concrete fill.

602.07 Cold Weather Placement

The following amended requirements of Standard Specification Section 502, Structural Concrete, Subsection 502.08, Cold Weather Concrete, will apply.

The Cold Weather Temperature Table does not apply to flowable concrete fill. The minimum concrete temperature as placed shall be 40°F. No housing framework or heating will be required when placed under approved cold weather conditions.

602.08 Forms and Containment Berms

When necessary to contain flowable concrete fill within a defined area, berms shall be constructed of compacted granular material.

602.09 Placing Flowable Concrete Fill

Flowable concrete fill shall not be placed until forms and/or containment berms have been checked and approved. Flowable concrete fill shall not be placed under water. The method and sequence of placing flowable concrete fill shall be approved by the Resident before any flowable concrete fill is placed.

All flowable concrete fill shall be placed before it has taken its initial set. Flowable concrete fill shall be placed in such a manner as to avoid separation and segregation of the mix. Consolidation, tamping, and vibration is not required or allowed.

Flowable concrete fill shall be discharged directly from the truck into the space to be filled. The drop height of the flowable concrete fill shall be as low as practicable. Flowable concrete fill shall not flow down the vertical face of a trench causing erosion of the trench face. Finishing and curing of flowable concrete fill is not required.

Flowable concrete fill placed will not be opened to traffic or covered with structural concrete or pavement for a minimum of 24-hours.

602.10 Method of Measurement

Flowable Concrete Fill satisfactorily placed and accepted will be measured by the cubic yard, in accordance with the pay limits established, if such limits have been established. If the Contractor elects to omit forms or berms, then any excavation or Flowable Concrete Fill placed beyond the pay limits as indicated on the Plans will not be paid for and shall be at the Contractor's own expense.

602.11 Basis of Payment

Accepted Flowable Concrete Fill will be paid for at the Contract unit price per cubic yard. Payment will be full compensation for furnishing and placing Flowable Concrete Fill, including placing and removing all forms, berms, granular material, pumping, dewatering, and any other necessary incidentals.

Payment will be made under:

Pay Item

Pay Unit

602.30	Flowable Concrete Fill	Cubic Yard
--------	------------------------	------------

SPECIAL PROVISION
SECTION 603
Pipe
(Reinforced Concrete Pipe)

603.10 Basis of Payment This section shall be amended with the addition of the following:

<u>Pay Item</u>		<u>Pay Unit</u>
603.155	12 Inch Reinforced Concrete Pipe Class III	Linear Foot
603.165	15 Inch Reinforced Concrete Pipe Class III	Linear Foot
603.205	30 Inch Reinforced Concrete Pipe Class III	Linear Foot

SPECIAL PROVISION
SECTION 604
MANHOLES AND CATCH BASINS
(Catch Basin)

609.10 Basis of Payment This section shall be amended with the addition of the following:

<u>Pay Item</u>		<u>Pay Unit</u>
604.076	60 Inch Catch Basin Type A1-C	Each
604.077	72 Inch Catch Basin Type A1-C	Each
604.093	60 Inch Catch Basin Type B1	Each
604.094	72 Inch Catch Basin Type B1	Each

SPECIAL PROVISION
SECTION 609
CURB
(Special Granite Curb – 39”)

609.01 Description This work shall consist of constructing special granite curb, 39” in height, as shown on the plans and as directed by the Resident.

609.02 Materials Except as provided below, materials shall meet the requirements specified in the following Section of Division 700 - Materials:

Stone Curbing and Edging

712.04

The vertical curb shall be 39” in height. End curbing units shall be tapered in the vertical by an 8:1 slope to match into existing ground. The front face of the curb end units in elevation shall be chamfered by a 30:1 ratio, beginning with an 8” curb thickness at the very end of the curb. The curb shall be imbedded a minimum of 2 feet.

609.09 Method of Measurement Special Granite Curb – 39” will be measured by the linear foot along the front face of the curb at the finished grade elevation, complete in place and accepted.

609.10 Basis of Payment The accepted quantities of Special Granite Curb – 39” will be paid for at the contract unit price per linear foot.

Payment will be made under:

Pay Item

609.1111 Special Granite Curb – 39”

Pay Unit

Linear Foot

SPECIAL PROVISION
SECTION 609
CURB
(Terminal Curb Type 1)

609.09 Method of Measurement Terminal Curb will be measured by the linear foot along the front fac of the curb at the elevation of the finished pavement, complete in place and accepted.

609.10 Basis of Payment The accepted quantities of Terminal Curb will be paid for at the contract unit price per linear foot.

This section shall be amended with the addition of the following:

<u>Pay Item</u>		<u>Pay Unit</u>
609.221	Terminal Curb Type 1	Linear Foot
609.222	Terminal Curb Type 1 - Circular	Linear Foot

SPECIAL PROVISION
SECTION 609
CURBING
(Truck Apron)

Section 609 - Curbing is amended by the addition of the following:

609.01 Description This work shall consist of installing Curb Type 5 around the perimeter of the truck apron, as shown on the plans.

609.05 Construction Requirements The curb shall be set at a 4:1 slope with a 3 inch reveal. The curb shall be placed on 16"x8"x4" precast concrete supports. Two supports will be required per section of curb. Grout or shims shall be used in order to set the curb to grade prior to placing Class A concrete bedding. Details for precast concrete supports and pay limits for concrete are as shown on the plans.

609.09 Method of Measurement Curb Type 5 – Truck Apron will be measured by the linear foot along the front face of the curb at the elevation of the finished pavement, complete in place and accepted.

609.10 Basis of Payment The accepted quantity of Curb Type 5 – Truck Apron will be paid for at the contract unit price per linear foot, complete in place. Payment shall be full compensation for furnishing curb, Class A concrete bedding, precast concrete supports, grout, shims, and all labor and incidentals necessary to satisfactorily complete the work.

Payment will be made under:

<u>Pay Item</u>		<u>Pay Unit</u>
609.341	Curb Type 5 – Truck Apron	Linear Foot

SPECIAL PROVISION
SECTION 627
Pavement Markings
(Preformed Thermoplastic Pavement Markings)

627.01 Description This work shall consist of furnishing and placing reflective preformed thermoplastic pavement markings in conformity with the Plans, as specified herein and as directed by the Resident.

627.02 Materials

- A. For the Solid Lane Lines, Pavement Marking Tapes shall be 3M Stamark™ High Performance Tape Series 380AW– High Performance pavement marking tape, six (6) inch wide, as manufactured by 3M of St. Paul, Minnesota.
- B. For the Broken White Lane Line (BWL), Pavement Marking Tape shall be 3M Stamark™ High Performance Tape Series 380AW– High Performance pavement marking tape, six (6) inch width, as manufactured by 3M of St. Paul, Minnesota.
- C. For the Dotted White Thermoplastic Extension Line (DWTL), preformed thermoplastic pavement markings shall be 3M Stamark™ Pavement Marking Tape Series A270ES pavement marking tape, sixteen (16) inches wide, as manufactured by 3M of St. Paul, Minnesota.

3M Traffic Safety Systems Division
Mr. Michael D. Allen
Tel: (401) 368-0438
Email: mdallen@mmm.com

627.04 Construction and Installation

- A. The Contractor shall mill a groove in the pavement for each tape length to be placed (“in-and out” pattern). Continuous grooving for installation of the tape shall not be allowed. The groove length shall be the required tape length plus 12 inches on both ends. The groove width for inlaid tape pavement marking shall be the pavement marking width plus 1 inch, with a tolerance of $\pm \frac{1}{4}$ inch. The groove shall have a uniform depth of 150 Mils (± 20 Mils). Groove position shall be a minimum of 2 inches from the edge of the pavement marking to the longitudinal pavement joint. The bottom of the groove shall have a smooth, flat finished surface. The use of gang stacked Diamond cutting blades is required for asphalt pavement surfaces. The spacers between blade cuts shall be such that there will be less than a 10 mil rise in the finished groove between the blades.

- B. Grooves shall be clean, dry and free of laitance, oil, dirt, grease, paint or other foreign contaminants. The Contractor shall prevent traffic from traversing the grooves, and re-clean grooves, as necessary, prior to application of the primer and pavement marking tape. Depth plates shall be provided by the contractor to assure that desired groove depth is achieved.
- C. Reference is made to 3M Information Folder 5.18 Grooving Applications, May 2011, "Application Guidelines for Pavement Marking in Grooved Pavement Surfaces."

609.09 Method of Measurement The quantity of Thermoplastic Pavement Markings measured for payment will be by the square foot of markings in place and accepted.

609.10 Basis of Payment The accepted quantities of Thermoplastic Pavement Markings will be paid for at the contract unit price per square foot, which price shall include all material, pavement grooving, equipment, labor, and incidentals necessary to complete the work.

Payment will be made under:

<u>Pay Item</u>		<u>Pay Unit</u>
627.941	Preformed Thermoplastic Pavement Markings	Square Foot

Highway Lighting Quality Control Checklist

Subsection 634.09 Field Testing

Project Pin # _____

Location (if multiple services, please be specific)- _____

Grounding Electrode Resistance at service _____

Number of Circuits _____

Hand-Off-Auto Switch? _____

Circuit #1

Open Circuit Resistance- (Ohm out both hot legs at the cabinet while they are shorted together at the last pole and the fuse holders are disconnected at each pole) _____

Megger Test- (Meg out both hot legs to ground at the cabinet while they are shorted together at the last pole and the fuse holders are disconnected at each pole) _____

Current draw- (during normal operation) Leg #1 _____ Leg #2 _____

Operating Voltage at last pole _____

Circuit #2

Open Circuit Resistance- (Ohm out both hot legs at the cabinet while they are shorted together at the last pole and the fuse holders are disconnected at each pole) _____

Megger Test- (Meg out both hot legs to ground at the cabinet while they are shorted together at the last pole and the fuse holders are disconnected at each pole) _____

Current draw- (during normal operation) Leg #1 _____ Leg #2 _____

Operating Voltage at last pole _____

I, _____, certify that this work was done in accordance with subsection 643.14 and current NEC _____ guidelines, and when tested, was functioning as intended. (YEAR)

Electrician's Signature _____

Electrician's License # _____

Highway Lighting Quality Control Checklist

Subsection 634.09 Field Testing

Project Pin # _____

Location (if multiple services, please be specific)- _____

Grounding Electrode Resistance at service _____

Number of Circuits _____

Hand-Off-Auto Switch? _____

Circuit #3

Open Circuit Resistance- (Ohm out both hot legs at the cabinet while they are shorted together at the last pole and the fuse holders are disconnected at each pole) _____

Megger Test- (Meg out both hot legs to ground at the cabinet while they are shorted together at the last pole and the fuse holders are disconnected at each pole) _____

Current draw- (during normal operation) Leg #1 _____ Leg #2 _____

Operating Voltage at last pole _____

Circuit #4

Open Circuit Resistance- (Ohm out both hot legs at the cabinet while they are shorted together at the last pole and the fuse holders are disconnected at each pole) _____

Megger Test- (Meg out both hot legs to ground at the cabinet while they are shorted together at the last pole and the fuse holders are disconnected at each pole) _____

Current draw- (during normal operation) Leg #1 _____ Leg #2 _____

Operating Voltage at last pole _____

I, _____, certify that this work was done in accordance with subsection 643.14 and current NEC _____ guidelines, and when tested, was functioning as intended. (YEAR)

Electrician's Signature _____

Electrician's License # _____

Traffic Signal Quality Control Checklist

Subsection 643.14 Field Testing

Project Pin # _____

Grounding Electrode Resistance at service _____

ID tags on loop amps / detector cards? _____

Location _____

Street Approach	_____		
Loop #	_____	Resistance	_____
Phase #	_____	Meg to ground	_____
L,C, or R Lane	_____	Amount of bondo covering loop	_____
Pulse or Presence	_____		

Street Approach	_____		
Loop #	_____	Resistance	_____
Phase #	_____	Meg to ground	_____
L,C, or R Lane	_____	Amount of bondo covering loop	_____
Pulse or Presence	_____		

Street Approach	_____		
Loop #	_____	Resistance	_____
Phase #	_____	Meg to ground	_____
L,C, or R Lane	_____	Amount of bondo covering loop	_____
Pulse or Presence	_____		

I, _____, certify that this work was done in accordance with subsection 643.14 and current NEC _____ guidelines, and when tested, was functioning as intended. (YEAR)

Electrician's Signature _____

Electrician's License # _____

SPECIAL PROVISION
SECTION 634
HIGHWAY LIGHTING

634.093 Basis of Payment

Add a paragraph at the end of this section that says:

Lump Sum payment for the highway lighting system shall also be full compensation for furnishing, installing, and erecting bracket arms; luminaires; all materials, labor, equipment, tools, miscellaneous hardware, and incidentals; and associated wiring for mounting luminaires on utility poles as noted in the plans.

Lump Sum payment for the highway lighting system shall also be full compensation for furnishing and installing wiring in underground conduit, pole wiring and all other wiring, to connect the RRFBs to the electrical system; receptacles and wiring as shown of the plans; and installation of private electrical service as shown on the plans and details. Payment shall also include removal of existing electrical equipment, high mast light standards, and wiring as shown on the plans and details.

SPECIAL PROVISION
SECTION 643
TRAFFIC SIGNALS
(Rectangular Rapid Flashing Beacon Assembly)

Standard Specification Section 643 TRAFFIC SIGNALS is amended as follows.

643.01 Description

The following paragraph is added:

This work shall consist of installing Rectangular Rapid Flashing Beacons (RRFBs), signs, pedestrian lighting, and associated equipment and appurtenances, in accordance with these specifications and in conformity with the lines, grades, and dimensions shown on the Plans or established herein.

This work shall consist of removal and stacking of existing RRFB assemblies and will be delivered to the City of Augusta as directed by the Resident.

643.02 General

The following paragraphs are added:

643.025 RRFB Assembly

RRFBs and signs for each crosswalk shall meet the latest version of the Manual on Uniform Traffic Control Devices (MUTCD) Chapter 4L – Rectangular Rapid-Flashing Beacons. RRFBs will be located at 66 Industrial Drive in Augusta, Maine. Contractor will be responsible for picking up, assembling, and installing RRFBs.

The proposed RRFBs shall also conform to the following requirements:

1. Each RRFB Assembly shall include equipment visible for each direction of vehicular traffic unless otherwise shown on the plans. Said equipment shall include two W11-2 signs (back-to-back on each support with the walking figure always facing the roadway), two W16-7P signs (back-to-back with the arrows pointing diagonally down in the direction of the crosswalk), and two RRFB units (back-to-back).
 - a. The RRFB shall be placed in front of the crosswalk for both directions of vehicular travel to provide an overhead, front-lit crosswalk.
2. A confirmation light directed at and visible to pedestrians in the crosswalk shall be installed integral to the RRFB to give confirmation that the RRFB is in operation.

3. Pedestrian activated push buttons shall be used and placed at the crosswalk landings a maximum of 48 inches above finish sidewalk landing grade.
 - a. A pedestrian instruction sign with the legend PUSH BUTTON TO TURN ON WARNING LIGHTS (R10-25) should be mounted adjacent to or integral with each pedestrian push button.
 - b. Push button actuation shall turn on the RRFBs and the Lighted Crosswalk (in roadway warning lights) concurrently.
 - c. The push button shall be compliant with MUTCD Section 4I.05.
4. Communications
 - a. Communication between the push button and the RRFB shall be hard-wired as required by the manufacturer.
 - b. Communication between devices on each end of the crosswalk shall be spread spectrum wireless or direct wire per the equipment provided.
5. Operation
 - a. Contractor is responsible for calculating walk intervals and programming RRFB flash times appropriately, as per MUTCD Part 4I.07
6. Lighting
 - a. Each assembly shall have two LED luminaires mounted to each pole for pedestrian vertical illuminance.
 - i. One luminaire shall be aimed at the detectable warning field.
 - ii. One luminaire shall be aimed towards the center of the adjacent travel lane.
 - b. The luminaires shall activate in conjunction with the RRFB, upon pushbutton actuation.
 - c. The luminaires shall activate when less than 1.0 fc of ambient light is present and shall not illuminate when the ambient light is equal to or greater than 1.0 fc.
 - d. The luminaires shall be housed in their own IP66 minimum rated enclosures.
 - e. The luminaires shall be adjustable for 120 degrees horizontally and vertically.
 - f. The LED luminaires shall provide vertical illuminance of 2.0 fc across the entire crosswalk, measured at a height of 5 feet above the road surface.
 - g. The luminaires shall be LED conforming to Section 715.08. Wattage of the luminaires shall be determined by the manufacturer sufficient to meet the required vertical illuminance criteria.
 - h. All other requirements for the luminaires shall be in accordance with Section 634.
7. Each support pole shall be installed with a square aluminum pedestal base with grounding lug.
8. All equipment shall be securely attached to the pole with sufficient banding or fasteners.
9. All wiring shall be located inside the pole to the maximum extent possible.

643.12 Painting

The following paragraphs are added:

All support poles and bases and the luminaire arms for the RRFB shall be delivered to the project finished with black enamel. The Contractor shall apply two coats of flat black enamel to all equipment designated to be painted black. The Contractor shall touch up all scratches with matching enamel after the equipment has been installed.

All equipment to be painted shall be cleaned and shall be dry when the paint is applied. No painting shall be done in damp weather nor when the air temperature is below 40 degrees F.

643.18 Method of Measurement

The following paragraph is added:

Rectangular Rapid Flashing Beacon Assembly will be measured for payment by each pair of assemblies installed complete in place.

Rectangular Rapid Flashing Beacon – Remove and Stack will be measured for payment by each pair of assemblies removed.

643.19 Basis of Payment

The following paragraphs are added:

Rectangular Rapid Flashing Beacon Assembly will be paid for at the Contract unit price by each. Payment will be full compensation for installing all materials including, but not limited to, the RRFB LED-arrays, LED vertical illuminance and luminaires, controller cabinet, Assembly painted support poles and breakaway bases, wiring, fasteners, pedestrian push buttons, signs, and all appurtenances and incidentals required for a complete and functioning system. Wiring, grounding, and associated electrical work and materials shall be incidental.

Rectangular Rapid Flashing Beacon – Remove and Stack will paid for at the Contract unit price by each. Payment will be full compensation for the removal of the entire existing RRFB assembly and delivery to the City of Augusta as directed by the Resident. Any damage to the assembly will repaired at no cost to the Department.

Foundations, removal of foundations, and conduit shall be paid for under applicable Section 626 pay items.

Payment will be made under:

<u>Pay Item</u>		<u>Pay Unit</u>
643.62	Rectangular Rapid Flashing Beacon – Remove and Stack	Each
643.621	Rectangular Rapid Flashing Beacon Assembly (Hard Wired)	Each

SPECIAL PROVISION
SECTION 643
TRAFFIC SIGNALS

The provisions of Section 643 of the Standard Specifications shall apply with the following additions and modifications:

643.01 Description

Work for this project shall include:

- The removal of existing span-wire vehicular signal equipment for all vehicular signal controls at the intersection of Bangor Street at Quimby Street and Linden Street
- The repurposing the existing traffic signal controller cabinet, existing conduits, wood poles, and strain poles as noted on the plans, and install new Pedestrian Hybrid Beacon (PHB) signal equipment and programming at the intersection of Bangor Street at Quimby Street and Linden Street,
- Modifying the existing traffic signal at the intersection of Bangor Street, North Belfast Avenue and Locke Street.

Existing equipment at both traffic signal locations, where indicated in the Plans, including: the existing controller cabinets, existing signal controllers, existing in-cabinet signal equipment, vehicular signal heads, light-emitting diode (LED) indications (as indicated in plans), retroreflective backplates on the vehicle signal heads, overhead mast arm mounted signs, non-invasive stop bar and advance vehicle detection, and emergency vehicle preemption that is not reused will either be delivered to MaineDOT or disposed of by the Contractor at the direction of the Resident.

Work for the Traffic Signal Modification at Bangor Street at Quimby Street and Linden Street shall include reusing existing traffic signal strain poles and span wire assemblies at the intersection. Existing materials, structures, or hardware damaged or lost during removing, storing, or resetting shall be replaced by the Contractor without additional compensation.

The Contractor shall install the following new equipment at the repurposed traffic signal of Bangor Street at Quimby Street and Linden Street into a PHB, including:

- Pedestrian Hybrid Beacons for Bangor Street approaches,
- Blank-out signs for no turn messaging during active pedestrian phase,
- Signal cabling and equipment wiring,
- Pedestrian signal heads with countdown timers,
- Accessible pedestrian signal (APS) equipment,
- Signal cabling and equipment wiring,
- Controller phasing and timing modifications,
- All appurtenances and incidentals required for complete functioning of the installation.

Work for the Traffic Signal Modification of Bangor Street at North Belfast Avenue and Locke Street shall include reusing existing traffic signal strain poles, span wire assemblies, vehicular detection, preemption detection and beacon assemblies, as well as resetting many of the vehicular signals at the intersection. Existing materials, structures, or hardware damaged or lost during removing, storing, or resetting shall be replaced by the Contractor without additional compensation. Existing materials that are not reused will be disposed of by the Contractor at the direction of the Resident.

The Contractor shall install the following new equipment at the modification of the existing traffic signal of Bangor Street at North Belfast Avenue and Locke Street, including:

- Pedestrian signal heads with countdown timers,
- Accessible pedestrian signal (APS) equipment,
- Leading Pedestrian Interval (LPI) for active, concurrent pedestrian phases,
- Signal cabling and equipment wiring,
- Controller phasing and timing modifications,
- All appurtenances and incidentals required for complete functioning of the installation.

Pedestrian equipment is to be installed under the guidelines of the Americans with Disabilities Act (ADA) having work integrated with curb ramp and detectable warning field improvements also being provided with this project.

All traffic signal controller timing parameters shall be programmed to provide free and coordinated operations.

643.211 Additional Materials. Materials shall also meet the requirements in the following Section of Division 700 - Materials:

Messenger Wire	718.15
Emergency Vehicle Preemption System	718.16
Pedestrian Crossing System	718.21

643.9 Service Connection. Add the following:

The Contractor shall maintain the existing ground rod array system of the existing controller cabinets for the intersections. If construction phases affect the existing ground rod array, the Contractor shall install 10-foot ground rods to a total of four and properly connect the ground rods together.

The Contractor shall be responsible for grounding the system to 5 ohms or less tested without an electrical connection to the utility neutral or ground conductor. The grounding shall be performed using a ground meter with reference grounds. If a 5-ohm reading is not achieved,

the Contractor shall install a chem-rod grounding electrode in close proximity to the cabinet. The chem-rod shall be properly connected to the four-rod grounding system in the cabinet. The chem-rod shall consist of a 10' copper rod (vertical or horizontal orientation) filled with common salt and desiccant, back filled with natural earth bentonite clay ground enhancement material. The chem-rod shall be installed per manufacturer's instructions. The location and orientation for the chem-rod installation shall be approved by the Resident. All testing shall be done in the presence of the Resident.

643.12 Painting. Unless otherwise directed by MaineDOT or through the Resident Engineer, all exterior parts of new equipment shall be delivered to the project finished as follows:

- Vehicular Signal Heads – all parts black.
- Pedestrian Signal Heads – all parts black.
- Accessible Pedestrian Signals (APS) – black.
- Signal Backplates – black and louvered w/ fluorescent yellow retroreflective strip.
- Controller Cabinets – black / aluminum.
- Mast Arms, Uprights, and Bases – black / galvanized steel.
- Pedestal Posts and Bases – black / aluminum.

643.18 Method of Measurement Removing and Resetting Pedestal Poles shall be measured for payment by the single units complete in place and accepted.

643.19 Basis of Payment. Traffic signal modifications will be paid for at the contract lump sum price for the intersection, which payment will be full compensation for furnishing and installing all new materials, including vehicular and pedestrian signal heads, risers, aerial disconnects, signal cable, and all appurtenances and incidentals required for complete functioning installations and for furnishing all tools and labor necessary for completing the installations. This will also include the reinstallation of existing mast arm poles on new concrete foundations with matching anchor bolt pattern, ancillary materials, tools, and labor necessary to erect and install the structures.

Removing and resetting pedestal poles will be paid for at the contract unit price of each which payment shall be full compensation for removing existing pedestal posts, ancillary materials and resetting them in their new location. Payment also includes the tools and labor necessary to perform the work. Removal of existing foundations and installation of new foundations, along with required conduit will be paid under applicable Section 626 pay items.

Payment will be made under the following:

<u>Pay Item</u>	<u>Pay Unit</u>
643.71 Traffic Signal Modification: Bangor St. at Quimby St. and Linden St.	Lump Sum
643.71 Traffic Signal Modification: Bangor St. at North Belfast Ave.	Lump Sum
643.922 Remove and Reset Pedestal Pole	EA

SPECIAL PROVISION
SECTION 652
MAINTENANCE OF TRAFFIC

Approaches. Approach signing shall include the following signs at a minimum. Field conditions may warrant the use of additional signs as determined by the Resident.

Road Work Next X* Miles
Road Work 500 Feet (Ahead)
End Road Work

Work Areas. At each work site, signs and channelizing devices shall be used as directed by the Resident.

Signs include:

Road Work xxxx¹.
One Lane Road Ahead
Flagger Sign

Other typical signs include:

Be Prepared to Stop
Low Shoulder
Bump
Pavement Ends

The above lists of Approach signs and Work Area signs are representative of the contract requirements. Other sign legends may be required.

Unless otherwise defined in Special Provision 105/107 or submitted and approved in the Traffic Control Plan, the following shall apply:

- The Contractor shall conduct their operations in such a manner that the roadway will not be restricted to one lane for more than 2,500 feet at each work area and no more than 4,000 feet for paving, milling, and crack seal/repair work areas.
- Where more than one work area restricts traffic to one lane operation, these work areas shall be separated by at least 1 mile of two-way operation.

Temporary Centerline A temporary centerline shall be placed each day on all new pavement to be used by traffic. The temporary centerline, when specified of reflectorized traffic paint, shall conform to the standard marking patterns used for permanent markings. Failure to apply a temporary centerline daily will result in a Traffic Control Violation and suspension of paving operations until temporary markers are applied to all previously placed pavement.

¹ “Road Work Ahead” to be used in short duration operations and “Road Work xx feet” to be used in stationary operations as directed by the Resident.

SPECIAL PROVISION
SECTION 803
UTILITY & DRAINAGE
TEST PITS

803.01 Description This work shall consist of excavating and backfilling test holes to locate existing utilities or drainage items at locations shown on the plans or as directed by the Resident.

803.02 General The work shall be done in a manner that provides safe passage of the traveling public at all times. Coordination with the utilities is required prior to, and during, the test pit activities. An authorized representative from the utility shall be present during the test pit activity. Test pits shall be completed in a manner that does not damage any utilities. Any damage to utilities or other roadway features by the test pit operations shall be repaired by the Contractor at no additional cost and shall be to the Resident's or utility's satisfaction.

The Contractor shall locate the utilities once exposed and provide coordinates and elevations to the Resident.

Once the location work is complete, the Contractor shall backfill the hole, place gravel and pavement or loam and seed over the test pits in a manner consistent with the existing conditions and in accordance with the standard specifications for backfilling including compaction requirements.

803.03 Method of Measurement Test Pits will be measured for payment by each, complete, backfilled, resurfaced, and accepted.

803.04 Basis of Payment The accepted quantity of Test Pits will be paid for at the contract unit price per each, which shall be full compensation for all labor, materials, tools, equipment, and incidentals necessary to complete the work. Associated traffic control will not be paid for separately and is included in the test pit item.

Payment will be made under:

<u>Pay Item</u>	<u>Pay Unit</u>
803.01 Test Pits	Each

SPECIAL PROVISION
SECTION 890
Special Work #1 – CMP Underground Relocation

890.01 Description This work shall consist of installing underground conduits, junction boxes, and all other necessary equipment as shown on the plan included in this Special Provision.

890.02 General The work shall be done in accordance with the information and requirements shown on the plan included in this Special Provision.

890.03 Method of Measurement Special Work #1 – CMP Underground Relocation will be measured by the lump sum.

890.04 Basis of Payment The accepted quantity of Special Work #1 - CMP Underground Relocation will be paid for at the contract lump sum price which shall be full compensation for all labor, materials, tools, equipment, and incidentals necessary to the complete the work as shown on the included plan. Associated traffic control will not be paid for separately and is considered incidental to the Special Work item.

Payment will be made under:

<u>Pay Item</u>	<u>Pay Unit</u>
890.01 Special Work #1 – CMP Underground Relocation	Lump Sum

2020 STANDARD DETAIL UPDATES

Standard Details and Standard Detail updates are available at:
<http://maine.gov/mdot/contractors/publications/standarddetail/>

<u>Detail #</u>	<u>Description</u>	<u>Posted Date</u>
502(06)	Concrete Sidewalk on Bridges	9/22/2025
502(19)	Bridge Drains	3/17/2023
502(15)	Bridge Drains	3/17/2023
502(20)	Bridge Drains	3/17/2023
502(23)	Bridge Drains	3/17/2023
502(24)	Bridge Drains	3/17/2023
502(25)	Bridge Drains	3/17/2023
502(26)	Bridge Drains	3/17/2023
504(07)	Diaphragm & Crossframe Notes	3/17/2023
507(04)	Steel Bridge Railing	9/22/2025
507(05)	Steel Bridge Railing	9/22/2025
507(06)	Steel Bridge Railing	9/22/2025
507(07)	Steel Bridge Railing	9/22/2025
507(14)	Steel Bridge Railing	9/22/2025
507(15)	Steel Bridge Railing	9/22/2025
507(20)	Steel Approach Railing 3-Bar	2/11/2021
507(21)	Steel Approach Railing 3-Bar	2/11/2021
507(22)	Steel Approach Railing, 3 Bar	9/22/2025
507(23)	Steel Approach Railing, 3 Bar	9/22/2025
507(26)	Steel Approach Railing, 3 Bar	9/22/2025
507(27)	Steel Approach Railing	9/22/2025
507(39)	Barrier – Mounted Steel Bridge Rail	9/22/2025
526(01)	Portable Concrete Barrier	1/14/2021
526(01A)	Portable Concrete Barrier	1/14/2021
526(01B)	Portable Concrete Barrier	1/14/2021
526(02)	Portable Concrete Barrier	1/14/2021
526(02A)	Portable Concrete Barrier	1/14/2021
526(03)	Portable Concrete Barrier	1/14/2021
526(04)	Portable Concrete Barrier	1/14/2021

526(04A)	Portable Concrete Barrier	1/14/2021
526(04B)	Portable Concrete Barrier	1/14/2021
526(05)	Permanent Concrete Barrier	3/17/2023
526(21)	Permanent Concrete Barrier	3/17/2023
526(22)	Concrete Transition Barrier	9/22/2025
526(23)	Concrete Transition Barrier	9/22/2025
526(23)A	Concrete Transition Barrier	9/22/2025
526(34)	Concrete Transition Barrier	9/22/2025
526(35)	Concrete Transition Barrier	9/22/2025
526(36)	Concrete Transition Barrier	9/22/2025
526(37)	Concrete Transition Barrier	9/22/2025
526(37) A	Concrete Transition Barrier	9/22/2025
526(38)	Concrete Transition Barrier	9/22/2025
526(39)	Texas Classic Rail	3/17/2023
526(55)	Texas Classic Rail	3/17/2023
603(10)	Concrete Pipe Ties	6/10/2021
605(01)	Underdrain	7/8/2022
605(01)	Underdrain Notes	7/8/2022
606(17)	Midway Splice Guardrail Transition	6/10/2022
606(21)	Guardrail Type 3 – Single Rail Bridge Mounted	9/22/2025
606(22)	Guardrail Treatment over Buried Structures	9/22/2025
606(23)	Standard Bridge Transition – Type “1”	2/11/2021
606(24)	Bridge Transition – Type “1A”	9/22/2025
606(25)	Bridge Transition – Type “2”	9/22/2025
607(10)	Snow Fence Details (New Detail)	9/22/2025
607(11)	Snow Fence Details (New Detail)	9/22/2025
607(12)	Snow Fence Details (New Detail)	9/22/2025
607(13)	Snow Fence Details (New Detail)	9/22/2025
607(14)	Snow Fence Details (New Detail)	9/22/2025
607(15)	Snow Fence Details (New Detail)	9/22/2025
607(16)	Snow Fence Details (New Detail)	9/22/2025
608(02)	Detectable Warnings	6/10/2021
609(08)	Precast Concrete Transition Curb	9/22/2025
609(09)	Precast Concrete Vertical Curb	9/22/2025
627(07)	Crosswalk	2/22/2022
627(08)	Crosswalk	2/22/2022

643(11)	ATCC Cabinet	12/14/2020
645(06)	H Beam Posts Highway Signing	12/17/2024
645(21)	Overpass Mounted Sign Support Highway Signing	9/22/2025
645 (22)	Overpass Mounted Sign Support Highway Signing	9/22/2025
<u>801(10)</u>	<u>Pavement Transition at Bridge</u> DISCONTINUE THIS STD DETAIL	9/22/2025
801(11)	Pedestrian Ramp Notes	11/20/2023
801(12)	Pedestrian Ramp Requirements	11/20/2023
801(13)	Ramp Length Table	11/20/2023
801(14)	Parallel Pedestrian Ramp	11/20/2023
801(15)	Perpendicular Pedestrian Ramp – Option 1	11/20/2023
801(16)	Parallel Pedestrian Ramp – Option 2A	11/20/2023
801(17)	Perpendicular Pedestrian Ramp – Option 2A	11/20/2023
801(18)	Parallel Pedestrian Ramp – Option 2B	11/20/2023
801(19)	Perpendicular Pedestrian Ramp – Option 2B	11/20/2023
801(20)	Parallel Pedestrian Ramp – Option 3	11/20/2023
801(21)	Perpendicular Pedestrian Ramp – Option 3	11/20/2023
801(22)	Side Street Pedestrian Ramp	11/20/2023
801(23)	Parallel Pedestrian Ramp – Esplanade	11/20/2023
801(24)	Perpendicular Pedestrian Ramp – Esplanade	11/20/2023
801(25)	Island Crossings	11/20/2023
801(26)	Blended Transition	11/20/2023
801(26)	Blended Transition	1/19/2024
801(27)	Pedestrian Ramp Adjacent to Driveway or Entrance	11/20/2023
802(05)	Roadway Culvert End Slope Treatment	1/03/2017
802(05)	Roadway Culvert End Slope Treatment	11/01/2024

SUPPLEMENTAL SPECIFICATIONS
(Corrections, Additions, & Revisions to Standard Specifications – March 2020)

SECTION 101
CONTRACT INTERPRETATION

101.2 Definitions

Construction Easement revise this definition by removing it in its entirety and replace with:
“A right acquired by the Department for a specific use of private property outside of the established Right-of-Way. Examples include but are not limited to Drainage Easements, Construction and Maintenance Easements, and Slope Easements. Construction Easement areas, including Temporary Construction Limits and Temporary Road Limits, outside of the Right-of-Way remain private property. No use other than to access and perform the specified work activity is permitted without written permission of the owner.”

Construction Limit Line Remove this definition in its entirety.

Holidays Amend this paragraph by adding “**Juneteenth**” between ‘Memorial Day’ and ‘Independence Day’.

Plans Revise this paragraph by removing “**Standard Details, Supplemental Standard Details**” from the first sentence.

Project Limits Revise this definition by removing it in its entirety and replacing it with:
“Areas within the Right-of-Way, Construction Easements, or Temporary Construction Limits shown on the Plans or otherwise indicated in the Contract. If no Project Limits are indicated in the Contract, the Project Limits shall be determined by the Department. For a related Maine statute, see 23 MRSA § 653. “

Right-Of-Way Revise this definition by removing it in its entirety and replacing it with:
“The area of land, property, or interest therein, acquired for or devoted to the Project or other purposes. Portions of the Right-of-Way may be used for storage of materials and equipment and the location of engineering facilities, subject to written approval by the Department.”

Amend this Section by adding the following two definitions (that replace Construction Limit Line);

Temporary Construction Limits **The area within which the Contractor may access and perform the Physical Work and outside of which Work may not be performed without written authorization by the property owner.**

Temporary Road Limits **The area within which the Contractor may construct and maintain a temporary detour for maintenance of traffic.**

SECTION 102 BIDDING

102.11 Bid Responsiveness Revise the paragraph that states
“The Bid is not signed by a duly authorized representative of the Bidder.” So that it reads:

“The Bid is not signed by a duly authorized representative of the Bidder.

- Properly submitted electronic bids meet this requirement.
- Paper bids must include at least one signed copy of the Contract Agreement Offer & Award form.”

SECTION 103 AWARD AND CONTRACTING

103.3.1 Qualification Requirement for Award Revise this subsection so that it reads:

“**103.3.1 Qualification Requirement for Award** If the Notice to Contractors lists a Prequalification requirement, the Apparent Successful Bidder must successfully complete the Prequalification process as a condition of Award. The Apparent Successful Bidder who does not already hold an Annual Prequalification shall have 21 days to provide the Department with their Prequal documents or the Department may move on to the next low bidder.”

SECTION 104 GENERAL RIGHTS AND RESPONSIBILITIES

104.2.1 Furnishing of Right-of-Way Revise this subsection by removing it in its entirety and replace with the new subsection:

“**104.2.1 Furnishing of Property Rights** The Department will secure all necessary rights to real property within the Project Limits shown on the Right-of-Way Plans that are provided with the Bid Documents. For related provisions, see Sections 104.3.2 – Furnishing of Other Property Rights, Licenses and Permits and 105.4.5 - Maintenance of Existing Structures. For related definitions, see Construction Easements and Right-of-Way.”

104.3.2 Furnishing of Other Property Rights, Licenses and Permits Revise this subsection by replacing “104.2.1 Furnishing of Right-of-Way” with “**104.2.1 Furnishing of Property Rights**”.

SECTION 105 GENERAL SCOPE OF WORK

Amend this Section by adding this new sub-section:

105.8.8 Protected Species If the Contractor witnesses a bat (dead or alive), any activities that may injure any live bats must cease immediately and the Contractor shall contact the

Resident. Dead and/or injured bats will be collected by the Department. Work in the vicinity of the live/dead bat sighting will not resume until the Department confirms it is acceptable to do so.

If the Contractor observes an active bird nest within the project limits, any activities that may disturb the nest or injure birds (i.e., nesting adults, chicks, eggs) must cease immediately, and the Contractor shall contact the Resident.

Amend this Section by adding this new sub-section to cover incidents in the field:

105.6.5 Survey Control Markers If a survey control marker will be disturbed by Work on a project, the Resident shall be informed a minimum of 2 weeks prior to performing any Work that may disturb the marker. If a survey control marker is accidentally disturbed by Work on a project, the Resident shall be informed immediately. A disturbed marker will remain the property of the Department.

105.10.1.4 Race-conscious Project Goals Revise the second paragraph of this section so it reads as follows:

“At the time of the bid opening, all Bidders shall submit with their bid a Disadvantaged Business Enterprise (DBE) Commitment Form provided by the Department. This form will list the DBE and non-DBE firms that are proposed to be used during the execution of the Work. This form must be filled out in its entirety. The dollar total of each commitment shall be totaled and a percentage determined.”

105.10.2 Requirements Applicable to All Contracts Under section A, number 2, in the first sentence of the first paragraph, revise this Section by replacing the word “handicap” in two places with the word “disability” so it now reads:

“2) The Contractor will, in all solicitations or advertisements for employees placed by or on behalf of the Contractor, State that all qualified applicants will receive consideration for employment without regard to race, color, sexual orientation, religious creed, sex, national origin, ancestry, age, physical disability, or mental disability.”

105.10.1.6 Bidders’ List Survey This section shall be revised to meet the May 9, 2024 CFR changes as follows:

Revise the title of this Section to “**Bidders’ List**” by removing the word “**Survey**”.

Revise the current information required to:

- (i) Firm name;**
- (ii) Firm address including ZIP code;**
- (iii) Firm's status as a DBE or non-DBE;**
- (iv) Race and gender information for the firm's majority owner;**
- (v) NAICS code applicable to each scope of work the firm sought to perform in its bid;**
- (vi) Age of the firm; and**

(vii) The annual gross receipts of the firm. You may obtain this information by asking each firm to indicate into what gross receipts bracket they fit (e.g., less than \$1 million; \$1-3 million; \$3-6 million; \$6-10 million; etc.) rather than requesting an exact figure from the firm.

Revise this section by removing the paragraph beginning with “This information...” and replacing it with the following:

“This data is required from all bidders for federally assisted contracts to be submitted with their bids as this information is critical in determining the availability of DBE Businesses relative to other businesses that do similar work.”

SECTION 106 QUALITY

106.6 Acceptance Revise this Subsection by replacing the paragraph beginning with “Acceptance of Hot Mix Asphalt Pavement will be based” with:

“Acceptance of Hot Mix Asphalt Pavement will be based on Method A or C Statistical Acceptance, or Method B or D Acceptance as specified. The method of acceptance for each item is defined in Special Provision, Section 403, Hot Mix Asphalt Pavement. When items of Hot Mix Asphalt Pavement are not so designated, Method A will be utilized whenever there are more than 1000 tons per Hot Mix Asphalt Pavement item, and Method B will be utilized when there are less than or equal to 1000 tons per Hot Mix Asphalt Pavement item.”

Revise Subsection “B” by removing it and replacing it with:

“B. Items not designated for Statistical Acceptance will utilize Method B or D Acceptance testing to validate the quality of the material incorporated into the Project. For material paid under Item 403.209 – Method D, or designated to be visually accepted, the Contractor shall provide the Department with a Certification Letter that indicates that the material supplied complies with the Specifications. Test results representative of the certified material shall be attached to the letter.

The Department will randomly sample and test the certified Material for properties noted in Table 1 of Section 502 - Structural Concrete or Table 14 of Section –401.21 Acceptance Method B & D. Material will be subject to rejection as noted in Structural Concrete Section 502.195 - Quality Assurance Method C Concrete or Hot Mix Asphalt, Section 401.2022 Pay Adjustment – Method B & D.”

106.7.1 Standard Deviation Method Revise 106.7.1, subsection H by removing the following from the first paragraph:

“Method B: $PF = [70 + (Quality\ Level * 0.33)] * 0.01$ ”

106.9.1 Warranty by Contractor Revise the third paragraph of this section so that it reads:

“For a related provision regarding obligations regarding plantings, see section 621.36 – Maintenance Period. “

SECTION 107
TIME

107.3.1 General Amend this paragraph by adding “**Juneteenth**” between ‘Patriot’s Day’ and ‘the Friday after Thanksgiving’.

SECTION 108
PAYMENT

108.2.3 Mobilization Payments Replace Standard Specification 108.2.3 – Mobilization Payments with the following:

“108.2.3 Mobilization Payments “Mobilization” includes the mobilization and demobilization of all resources as many times as necessary during the Work.

Percent Mobilization Bid will be determined by taking the amount Bid for Mobilization and dividing by the Total Contract Amount less Mobilization. Mob/(Total Contract – Mob).

Payment will be made at the following intervals:

% Mobilization Bid	% Mobilization Paid at Contract Award	% Mobilization Paid after the Department determines 50% of the work is Complete	% Mobilization Paid at Final Acceptance
10% or less	50%	50%	
More than 10% to 15%	33%	33%	34%
More than 15% to 20%	25%	25%	50%
More than 20% to 30%	15%	15%	70%
Greater than 30%	10%	10%	80%

108.3 Retainage Revise the third paragraph of this section so that it reads:

“Upon Final Acceptance, and determination by the department that there are no claims either by or on the Contractor or Subcontractors; no over payments by the department; no LDs due; and no disincentives due, the Department will reduce Retent to 1% of the original Contract Award amount, or \$100,000, whichever is less, as it deems desirable and prudent.”

108.4.1 Price Adjustment for Hot Mix Asphalt Revise this section by removing it in its entirety and replacing it with the following:

108.4.1 Price Adjustment for Hot Mix Asphalt: For each Contract, a price adjustment for performance graded binder will be made for the following pay items, when the total quantity of Hot Mix Asphalt included in these items is in excess of 500 tons, based on the estimated quantities of these items at the time of bid.

Item 403.102	Hot Mix Asphalt – Special Areas
Item 403.207	Hot Mix Asphalt - 19 mm
Item 403.2071	Hot Mix Asphalt - 19 mm (Polymer Modified)
Item 403.2072	Hot Mix Asphalt - 19 mm (Asphalt Rich Base)
Item 403.208	Hot Mix Asphalt - 12.5 mm
Item 403.2081	Hot Mix Asphalt - 12.5 mm (Polymer Modified)
Item 403.2084	Hot Mix Asphalt - 12.5 mm (Highly Modified HiMAP)
Item 403.209	Hot Mix Asphalt - 9.5 mm (sidewalks, drives, & incidentals)
Item 403.210	Hot Mix Asphalt - 9.5 mm
Item 403.2101	Hot Mix Asphalt - 9.5 mm (Polymer Modified)
Item 403.2104	Hot Mix Asphalt - 9.5 mm (Thin Lift Surface Treatment)
Item 403.21041	Hot Mix Asphalt - 9.5 mm (Polymer Modified Thin Lift Surface Treatment)
Item 403.211	Hot Mix Asphalt – Shim
Item 403.2111	Hot Mix Asphalt – Shim (Polymer Modified)
Item 403.212	Hot Mix Asphalt - 4.75 mm (Shim)
Item 403.213	Hot Mix Asphalt - 12.5 mm (base and intermediate course)
Item 403.2131	Hot Mix Asphalt - 12.5 mm (base and intermediate course Polymer Modified)
Item 403.2132	Hot Mix Asphalt - 12.5 mm (Asphalt Rich Base and intermediate course)
Item 403.301	Hot Mix Asphalt (Asphalt Rubber Gap-Graded)
Item 461.13	Light Capital Pavement
Item 461.210	9.5 mm HMA - Paver Placed Surface
Item 461.2101	Hot Mix Asphalt - 9.5 mm (Polymer Modified)
Item 461.216	Hot Mix Asphalt (Shim)
Item 462.30	Ultra-Thin Bonded Wearing Course
Item 462.301	Polymer Modified Ultra-Thin Bonded Wearing Course

Price adjustments will be based on the variance in costs for the performance graded binder component of hot mix asphalt. They will be determined as follows:

The quantity of hot mix asphalt for each pay item will be multiplied by the performance graded binder percentages given in the table below times the difference in price between the base price and the period price of asphalt cement. Adjustments will be made upward or downward, as prices increase or decrease.

- Item 403.102–6.2%
- Item 403.207–5.2%
- Item 403.2071–5.2%
- Item 403.2072–5.8%
- Item 403.208–5.6%
- Item 403.2081–5.6%
- Item 403.2084 – 6.2%
- Item 403.209–6.2%
- Item 403.210–6.2%
- Item 403.2101–6.2%
- Item 403.2104–6.2%
- Item 403.21041–6.2%
- Item 403.211–6.2%
- Item 403.2111–6.2%
- Item 403.212–6.8%
- Item 403.213–5.6%
- Item 403.2131–5.6%
- Item 403.2132–6.2%
- Item 403.301–6.2%
- Item 461.13–6.7%
- Item 461.210 – 6.4%
- Item 461.2101 – 6.4%
- Item 461.216 – 6.7%
- Item 462.30–0.0021 tons/SY
- Item 462.301–0.0021 tons/SY”

SECTION 110 INDEMNIFICATION, BONDING, AND INSURANCE

110.3.2 Commercial General Liability Revise the last sentence in this Section that starts with “The coverage shall also...” and add a sentence to the end so that it reads:

“The coverage shall also include protection against damage claims due to explosives, collapse, and underground coverage. No endorsement excluding damage caused by subsidence, earth movement, and/or earth pressure shall be permitted.”

110.3.9 Administrative & General Provisions Amend this subsection by adding “**Automobile Liability**” under letter A) Additional Insured to the list of exceptions.

10. Assurance Required by 49 CFR: 26.13(a)(b) Revise this section by removing it in its entirety and replacing it with the following:

“a. MaineDOT shall not discriminate on the basis of race, color, national origin, or sex in the award and performance of any DOT-assisted contract or in the administration of its DBE Program or the requirements of 49 CFR part 26. MaineDOT shall take all necessary and reasonable steps under 49 CFR part 26 to ensure nondiscrimination in the award and administration of DOT-assisted contracts. MaineDOT’s DBE Program, as required by 49 CFR part 26 and as approved by DOT, is incorporated by reference in this agreement. The implementation of this program is a legal obligation and failure to carry out its terms shall be treated as a violation of this agreement. Upon notification to the MaineDOT of its failure to carry out its terms shall be treated as a violation of this agreement. Upon notification to the MaineDOT of its failure to carry out its approved program, the Department may impose sanctions as provided for under 49 CFR Part 26, and may, in appropriate cases, refer the matter for enforcement under 18 U.S.C. 1001 and/or the Program Fraud Remedies Act of 1986 (31 U.S.C. 3801 et seq.). This language will appear in financial assistance agreements with sub-recipients.

b. The contractor, sub-recipient, or subcontractor shall not discriminate on the basis of race, color, national origin, or sex in the performance of this contract. The contractor shall carry out applicable requirements of 49 CFR part 26 in the award and administration of DOT assisted contracts. Failure by the contractor to carry out these requirements is a material breach of this contract, which may result in the termination of this contract or such other remedy as the recipient deems appropriate, including, but not limited to:

- 1. Withholding monthly progress payments;**
- 2. Assessing sanctions;**
- 3. Liquidated damages; and/or**
- 4. Disqualifying the contractor from future bidding as non-responsible.”**

SECTION 206 STRUCTURAL EXCAVATION

206.01 Description – *Structural Earth Excavation, Below Grade* delete the entire sentence and replace with **“shall consist of the removal of excavation required for unknown or unanticipated subsurface condition. See 206.04 – Method of Measurement for pay limits.”**

206.04 Method of Measurement – Drainage and Minor Structures Paragraph 1, sentence 2, delete the remainder of the sentence beginning with “...provided the maximum allowable...” And replace with: **“...in accordance with the following limits:”**

- Vertical pay limits:**

- **Below a plane parallel with and 12 inches below the bottom of the drainage or minor structure or**
 - **Below the excavation limits shown in the Bid Documents; whichever is greater.**
- **Horizontal pay limits – The maximum allowable horizontal dimensions shall not exceed those bounded by vertical surfaces 18 inches outside the base, or extreme limits of, the structure, and to the vertical neat lines of underdrain trenches, as shown in the Contract Documents.**

SECTION 401 HOT MIX ASPHALT PAVEMENT

401.19 Contractor Quality Control Amend this Section by adding the following to the end:
“Failure to comply with the approved QCP will result in work suspension and pay reductions as outlined in Section 106.4.6. The Quality Control Plan Value shall be the total bid value for all items covered by the QCP as identified in Special Provision 403.”

SECTION 501 FOUNDATION PILES

501.044 Special Requirements for Steel Pipe Piles and Steel Casings Amend this section by deleting it in its entirety and replacing with:

Pipe piles shall be driven closed ended, unless otherwise specified. When open-ended pipe piles are specified or when the ends are not completely closed ended when driven, the inside of the pile shall be thoroughly cleaned out, and the inside walls cleaned by jetting or other means approved by the Resident. The sediment control required for the cleaning operations shall be covered in the Contractor’s SEWPCP.

Pipe piles shall be inspected and approved by the Resident immediately before concrete is placed in them. They shall be free from rupture and undue deformation and shall be free from water unless the Resident determines that the concrete can be placed without damage to the pile and such that the discharged water will be contained. The Contractor shall provide lights and other equipment necessary to enable the Resident to inspect each pipe pile.

Portland cement concrete for filling the pipe piles shall be placed in one continuous operation to fill the pile completely without causing water contamination. An internal type vibrator shall be used in the top 25 feet. Pile heads shall be protected and cured in accordance with Section 502, Structural Concrete.

The placing of concrete and the driving of piles shall be scheduled so that fresh and setting concrete will not be injured by the pile driving.

Concrete shall not be placed in pipe piles until pile driving has progressed beyond a radius of 15 feet from the pile to be concreted. If pile heave is detected for pipe piles that have been filled with concrete, the piles shall be redriven to the original position after the concrete has attained sufficient strength and a proper hammer-pile cushion system, is in place and is satisfactory to the Resident.

When a reinforcing steel cage is specified, it shall be placed inside the piles to allow for a minimum of 2 inches of concrete cover and the piles shall be filled with concrete to the elevation shown on the Plans.

Full-length pipe piles and steel casings shall be used wherever practicable; however, splicing may be permitted when approved by the Resident. The method of splicing shall be as follows:

- a. Steel pipe piles and steel casings shall be spliced by full penetration butt joint welds.
- b. When the pipe piles and steel casings are to be spliced while in a vertical position, splicing shall be accomplished utilizing single-bevel groove welds with the use of back-up rings. When the pipe piles and steel casings are to be spliced while in a horizontal position, splicing shall be accomplished utilizing single-vee groove welds with the use of back-up rings.
- c. Welded joints shall conform to the Standard Details.

501.047 Splicing Piles Amend this section by deleting it in its entirety and replacing it with:

Full-length piles shall always be used wherever practicable. When full-length piles cannot be used, the number of splices, locations, and details shall be noted in the QCP. Piles fabricated from multiple pieces will be acceptable only if they comply with the following:

H-Beam Piles ^a		Pipe Piles and Steel Casings ^{a,b}	
Lengths	Maximum No. Field Splices	Lengths	Maximum No. Field Splices
Less than 20 ft.	0	Less than 20 ft.	0
Over 20 – 35 ft.	1	Over 20 – 40 ft.	1
Over 35 – 79 ft.	2	Over 40 – 60 ft.	2
Over 79 ft.	1 per 40 ft.	Over 60 – 80 ft.	3
		Over 80 ft.	1 per 20 ft.

^a Pile lengths less than 10 feet will not be spliced, except as the final (top) section of the pile.
^b Where pipe piles are used for pile bent piers, no splices will be allowed in the length of pile from the cutoff elevation to 2 feet below the channel bottom.

When pre-planned splicing is approved, the pile piece of lesser length shall be placed at the tip of the pile (the first part of the pile that enters the ground).

When splicing is allowed, the work shall be done in accordance with the following:

- A. Welding shall be done in accordance with the requirements of the AWS D1.1 welding code.**
- B. Qualify welders in accordance with the most recent edition of the AWS D1.5 code.**
- C. Submit a written Weld Procedure Specification (WPS) for each joint to be included as part of the QCP. The WPSs shall be provided to the Fabrication Engineer for review and approval prior to beginning welding. Provide copies of the approved WPSs to the welder, QC Inspector and Resident prior to beginning welding. Welding performed without an approved WPS and approved QCP will be considered Unacceptable Work.**
- D. Provide a list of qualified welders with copies of their AWS certifications to the Fabrication Engineer for review prior to beginning welding. Welders shall have in their possession, at the time of welding, a valid certification for the process and position to be used in production from the AWS. The welder shall show the Resident their credentials upon request.**
- E. The Contractor shall only use electrodes that are on the Department's Qualified Products List for Welding Electrodes or shall submit alternative electrodes for review and approval by the Fabrication Engineer. Electrodes used shall match those approved for use in the WPS.**
- F. Welding shall not be done: When the temperature in the immediate vicinity of the weld is below 0°F; when the surfaces are damp or exposed to rain, snow, or high wind; or when the welders or welding operators are exposed to inclement conditions.**
- G. The pile shall be preheated to and maintained at 150°F minimum, within 6 inches from the joint during welding.**
- H. Power sources for welders shall have meters indicating amperage/voltage that have been calibrated within 1 year at the time of welding.**
- I. The Contractor shall provide the Department with notice, a minimum of, 7 Days prior to the start of any welding.**
- J. The Contractor shall provide a QC Inspector to perform QC for the welds in accordance with the AWS D1.1 welding code. The QC Inspector shall be an AWS Certified Welding Inspector (CWI) in conformance with the requirements of AWS QC1, Standard for AWS Certifications of Welding Inspectors. The Contractor may submit, in lieu of a CWI, an alternative QC Inspector with documented training and experience in metals fabrication, inspection, and testing for approval by the Fabrication Engineer. The QC Inspector shall be someone other than the welder performing the welds to be inspected.**
- K. The QC Inspector shall inspect all production stages of the welded splice to ensure that workmanship and materials meet the requirements of the AWS D1.1 welding code and the Contract. The QC Inspector shall submit a signed record of all weld inspection documentation to the Resident after welding is completed.**

Record of weld inspection shall include, but not be limited to, the following:

- 1. Name of QC Inspector**
- 2. Project WIN and Location**
- 3. Date**
- 4. Weather conditions**
- 5. Type, size, length, and location of welds.**

6. **Confirmation of appropriate equipment and materials used, including proper handling of welding electrodes.**
7. **Confirmation that welder has approved WPS onsite, and welding is performed in accordance with approved WPS.**
8. **Confirmation that welder is qualified to perform work per approved WPS. Include name and certifications of qualified welder who performed the work.**
9. **Confirm that 100% visual testing, in accordance with AWS D1.1 Table 8.1, has been conducted and any subsequent repairs are made prior to non-destructive testing (NDT).**
10. **Document NDT testing including name of NDT technician, NDT personnel qualifications, type and extent of NDT testing performed, and include NDT testing reports provided by the NDT testing technician.**

L. **Piles shall not be driven until all pile welding has been inspected and accepted by the Department.**

501.0471 Specific Requirements for Splicing H-Beam Piles

- A. Damaged material shall be removed from the end of the driven pile. Lifting holes shall be repaired or trimmed off. The ends of both pieces to be spliced shall be cut off square with the longitudinal axis of the pile and beveled per the approved WPS. All cutting shall be done with the use of a mechanical guide, except that minor trimming may be allowed, as approved by the Resident.
- B. The Contractor shall use an approved mechanical splicer or a full penetration butt weld for the entire cross section of the pile. Mechanical splicers shall be installed per the manufacturer's recommendations, except that the flanges shall be welded using a complete joint penetration weld, per the AWS D1.1 welding code.
- C. In addition to the 100% visual testing (VT) performed by the QC Inspector, the Contractor shall perform NDT on the first two welded splices of the same type/size. The welds shall be radiographically (RT) or ultrasonically (UT) tested for their full length for acceptance per Table 8.2 of AWS D1.1. If both RT/UT-tested splices are determined to be acceptable, no further NDT will be required. If either of the first two RT/UT-tested splices contain defects warranting rejection, RT/UT testing of splices shall continue until two consecutive splices are found to be acceptable.
- D. Should the Department determine that the Quality Control of the Contractor is not producing welds with acceptable quality, then the Department may request the Contractor to perform additional NDT, such as RT or UT of any or all welds. Should the NDT testing identify defects warranting rejection, the welds shall be repaired and retested. The Contractor shall perform the NDT and weld repair work at no additional cost to the Department. If the NDT does not identify defects warranting rejection, then the Department will pay for the cost of the NDT testing. RT and UT defect indications will be evaluated according to the statically loaded criteria of AWS D1.1.

501.0472 Specific Requirements for Splicing Steel Pipe Piles and Steel Casings

- A. Damaged material shall be removed from the end of the driven pile. Lifting holes shall be trimmed off. The ends of both pieces to be spliced shall be cut off square with the

longitudinal axis of the pile and beveled per the approved WPS. All cutting shall be done with the use of a mechanical guide, except that minor trimming may be allowed, as approved by the Resident.

B. Splices shall be welded using an AWS D1.1 Complete Joint Penetration butt weld with a backer ring.

C. In addition to the 100% VT performed by the QC Inspector, the Contractor shall perform NDT on the first two welded splices of the same type/size. The welds shall be RT or UT tested for their full length for acceptance per Table 8.2 of AWS D1.1. If both RT/UT-tested splices are determined to be acceptable, no further NDT will be required. If either of the first two RT/UT-tested splices contain defects warranting rejection, RT/UT testing of splices shall continue until two consecutive splices are found to be acceptable.

D. Should the Department determine that the Quality Control of the Contractor is not producing welds with acceptable quality, then the Department may request the Contractor to perform additional NDT, such as RT or UT of any or all welds. Should the NDT testing identify defects warranting rejection, the welds shall be repaired and retested. The Contractor shall perform the NDT and weld repair work at no additional cost to the Department. If the NDT does not identify defects warranting rejection, then the Department will pay for the cost of the NDT testing. RT and UT defect indications will be evaluated according to the statically loaded criteria of AWS D1.1.

501.048 Prefabricated Pile Tips Amend this section by deleting it in its entirety and replacing it with:

Welding of pile tips shall be done in accordance with the following:

A. Welding shall be done in accordance with the requirements of the AWS D1.1 welding code.

B. Qualify welders in accordance with the most recent edition of the AWS D1.5 code.

C. Submit a written WPS for each tip to be included as part of the QCP. The WPSs shall be provided to the Fabrication Engineer for review and approval prior to beginning welding. Provide copies of the approved the WPS to the welder and Resident prior to beginning welding. Welding performed without an approved WPS and approved QCP will be considered Unacceptable Work.

D. Provide a list of qualified welders with copies of their AWS certifications to the Fabrication Engineer for review prior to beginning welding. Welders shall have in their possession, at the time of welding, a valid certification for the process and position to be used in production from the AWS or other organization acceptable to the Resident. The welder shall show the Resident their credentials upon request.

E. The Contractor shall only use electrodes that are on the Department's Qualified Products List for Welding Electrodes or shall submit alternative electrodes for review and approval by the Fabrication Engineer. Electrodes used shall match those approved for use in the WPS.

F. Pile tips shall be approved by the Resident.

G. Welding shall not be done: When the temperature in the immediate vicinity of the weld is below 0°F; when the surfaces are damp or exposed to rain, snow, or high wind; or when the welders or welding operators are exposed to inclement conditions.

H. The pile shall be preheated to and maintained at 150°F minimum within 6 inches from the joint during welding.

I. Power sources for welders shall have meters indicating amperage/voltage that have been calibrated within 1 year at the time of welding.

J. Pile tips may be welded to the piles by the pile supplier upon approval by the Department. Approval is contingent upon submission of the following: A welding QC Plan; proof that the proposed welder(s) is certified per AWS D1.5; and an AWS D1.1 WPS, with base metal preheated to a minimum of 150°F. The Contractor shall provide notice a minimum of 14 Days prior to the start of any welding by the pile supplier. At a minimum, welds shall be 100% visually inspected by the pile supplier's QC representative.

K. The Contractor shall provide a QC Inspector to perform QC for the welds in accordance with the AWS D1.1 welding code. The QC Inspector shall be an CWI in conformance with the requirements of AWS QC1, Standard for AWS Certifications of Welding Inspectors. The Contractor may submit, in lieu of a CWI, an alternative QC Inspector with documented training and experience in metals fabrication, inspection, and testing for approval by the Fabrication Engineer. The QC Inspector shall be someone other than the welder performing the welds to be inspected.

L. The QC Inspector shall inspect all production stages of the welded splice to ensure that workmanship and materials meet the requirements of the AWS D1.1 welding code and the Contract. The QC Inspector shall submit a signed record of all weld inspection documentation to the Resident after welding is completed.

M.

Record of weld inspection shall include, but not be limited to, the following:

- 1. Name of QC Inspector**
- 2. Project WIN and Location**
- 3. Date**
- 4. Weather conditions**
- 5. Type, size, length, and location of welds.**
- 6. Confirmation of appropriate equipment and materials used, including proper handling of welding electrodes.**
- 7. Confirmation that welder has approved WPS onsite, and welding is performed in accordance with approved WPS.**
- 8. Confirmation that welder is qualified to perform work per approved WPS. Include name and certifications of qualified welder who performed the work.**
- 9. Confirm that 100% VT, in accordance with AWS D1.1 Table 8.1, has been conducted and any subsequent repairs are made prior to NDT.**
- 10. Document NDT testing including name of NDT technician, NDT personnel qualifications, type and extent of NDT testing performed, and include NDT testing reports provided by the NDT testing technician.**

N. The Contractor shall provide notice a minimum of 7 Days prior to the start of any field welding.

- O. Piles shall not be driven until all pile welding has been inspected and accepted by the Department.

501.0481 Specific Requirements for Installing H-Beam Pile Tips

- A. Damaged material shall be removed from the end of the driven pile, as applicable. Lifting holes shall be trimmed off. The end of the pile to which the tip is to be attached shall be cut off square with the longitudinal axis of the pile and prepared per the approved WPS. All cutting shall be done with the use of a mechanical guide, except that minor trimming may be allowed, as approved by the Resident.
- B. Regarding weld size, prefabricated pile tips shall be attached to H-beam piles with 5/16-inch groove welds along each flange, or as recommended by the manufacturer of the pile tips, whichever weld size is larger.
- C. The QC Inspector shall, at a minimum, perform 100% VT on each pile tip weld.
- D. Should the Department determine that the Quality Control of the Contractor is not producing welds with acceptable quality, then the Department may request the Contractor to perform additional NDT, such as RT or UT of any or all welds. Should the NDT testing identify defects warranting rejection, the welds shall be repaired and retested. The Contractor shall perform the NDT and weld repair work at no additional cost to the Department. If the NDT does not identify defects warranting rejection, then the Department will pay for the cost of the NDT testing. RT and UT defect indications will be evaluated according to the statically loaded criteria of AWS D1.1.

501.0482 Specific Requirements for Installing Steel Pipe Pile Tips

- A. Damaged material shall be removed from the end of the driven pile, as applicable. Lifting holes shall be trimmed off. The end of the pile to which the tip is to be attached shall be cut off square with the longitudinal axis of the pile and prepared per the approved WPS. All cutting shall be done with the use of a mechanical guide, except that minor trimming may be allowed, as approved by the Resident.
- B. Unless otherwise shown on the Plans, steel pipe piles shall have pointed cast steel pile tips.
- C. Regarding weld size, prefabricated pile tips shall be attached to steel pipe piles with a continuous 5/16-inch groove weld along the full perimeter of the pile, or as recommended by the manufacturer of the pile tips, whichever weld size is larger.
- D. The QC Inspector shall, at a minimum, perform 100% VT on each pile tip weld.
- E. Should the Department determine that the Quality Control of the Contractor is not producing welds with acceptable quality, then the Department may request the Contractor to perform additional NDT, such as RT or UT of any or all welds. Should the NDT testing identify defects warranting rejection, the welds shall be repaired and retested. The Contractor shall perform the NDT and weld repair work at no additional cost to the Department. If the NDT does not identify defects warranting rejection, then the Department will pay for the cost of the NDT testing. RT and UT defect indications will be evaluated according to the statically loaded criteria of AWS D1.1.

501.05 Method of Measurement

c. Piles in Place Revise the third paragraph by replacing the “10” with “20” so that it reads:

Unused pile cutoffs **20** feet or more in length, except those required to accommodate the Contractor’s construction method, as discussed herein, will remain the property of the Department and will be stored at a bridge maintenance yard nearest the project. Hauling and unloading of piles will be done by the Contractor or by the Department, depending upon availability of services.

SECTION 502
STRUCTURAL CONCRETE

502.03 Materials Amend this section by adding the following to the list of materials:

Combined Aggregate Grading for Concrete 703.03

502.07 Mixing and Delivery Remove the last sentence in Paragraph A that starts with “With prior approval... and replace with the following:

“An approved hydration stabilizing admixture may be used to increase the discharge time. Justification for the need for a hydration stabilizing admixture shall be provided in the QC Plan. When a hydration stabilizing admixture is used, the manufacturer, dosage rate and discharge time, from the time cement is added to the aggregate, shall be documented in the approved QC Plan. The proposed discharge time(s) shall be based on the manufacturer’s written recommendations, the anticipated concrete temperatures and anticipated ambient conditions at the time of placement(s). Discharge time(s) shall be adjusted when conditions change or are not as anticipated as outlined in the approved QC Plan. The discharge time(s) approved by the Department shall be subject to change at any time, and discharge of concrete into the permanent work shall cease immediately if the concrete is determined to have attained Accelerated Hydration Gain. Accelerated Hydration Gain being the condition where the fresh concrete has hydrated to the point where the workability and finishability is detrimental to the quality of the final product. Determination of when concrete has attained Accelerated Hydration Gain shall be made by the Contractor’s Quality Control Technician(s) and shall be based on parameters proposed by the Contractor in the QC Plan, such as, but not limited to, loss of slump, plasticity, or workability, an increase in concrete temperature, or a change in the percentage of entrained air.”

502.09 Forms and Falsework Amend this subsection by adding the subsection title “**502.10 Placing Concrete**” after section “D” Removal of Forms and False work” and after the paragraph beginning with “2. Forms and False work, including blocking...”. So that a new subsection starts and reads:

“502.10 Placing Concrete

A. General Concrete shall not be placed until forms”

502.1701 Quality Control, Method A and B Revise this Section so that the first paragraph and the first sentence of the second paragraph read:

502.17 Quality Control The Contractor shall control the quality of the concrete through testing, inspection, and practices which shall be described in the QCP, sufficient to assure a product meeting the Contract requirements. The QCP shall meet the requirements of Section 106, Quality, and this specification. No work under this item shall proceed until the QCP is submitted to and approved by the Department. Failure to comply with the approved QCP will result in work suspension and pay reductions as outlined in Section 106.4.6. The Quality Control Plan Value shall be the total bid value for all cast-in-place items covered by the QCP, using the P value listed in Special Provision 502. If no P value is listed, a value of \$350, or bid value per cubic yard, whichever is less, shall be used.

502.1701 Quality Control, Method A and B The QCP shall address all elements that affect the quality of the structural concrete including, but not limited to, the following: “

Under the list with the heading, “The QCP shall address all elements that affect the quality of the structural concrete including, but not limited to, the following:”:

Replace “F” to read: “**Mix and Transportation, including Time from Batching to Completion of Delivery, as well as manufacturer, product name, proposed dosage(s) and discharge time(s) if a hydration stabilizing admixture is used.**”

Replace “H” to read: “**Process QC Testing, including monitoring for attainment of Accelerated Hydration Gain when a hydration stabilizing admixture is used.**”

Revise this section by replacing the paragraph before Table 4 that starts out “The Contractor shall maintain...” to read:

“The Contractor shall maintain records of all QC tests and calculations. All QC test data shall be signed by the person who performed the test. The representative gradation test results shall be reported to the Department before the placement they represent. This initial representative gradation test shall be sampled a maximum of 30 days prior to the production day. The Contractor or supplier shall retain split samples of the most recent QC gradations for possible testing by the Department. In addition, the Department will sample the aggregates at the plant monthly to determine compliance with 703.03 Combined Aggregate Grading for Concrete. The Combined Aggregate Grading will be calculated by mathematically blending the individual aggregate gradations using the batch percentages from the approved mix design. If the Department’s gradation tests determine that the aggregate does not meet the specified gradation limits, the current procedure mentioned in MaineDOT PCC Policies and Procedures Manual shall be followed. The compressive strength test results shall be reported to the Department by 10:00 A.M. of the first working day following the test. The Contractor shall record all onsite QC test data and calculations at the time of the placement and present this information, on a form acceptable to the Department, to the Department by 10:00 A.M. of the first working day following the concrete placement. Batch tickets shall be representative of that day’s total moisture in aggregate value, QC test data for total moisture in aggregate shall be provided to the

Department by 10:00 A.M. of the first working day following the concrete placement. All Method A and B QC testing shall meet the minimum requirements found in Table 4.”

Section 502.1701, Quality Control, Revise Table 4 of this Subsection by removing it in its entirety and replacing it with:

**TABLE 4
METHOD A & B MINIMUM QUALITY CONTROL TESTING REQUIREMENTS***

TEST	TEST METHOD	SAMPLING LOCATION	FREQUENCY
Gradation	AASHTO T 27 & T 11	Stockpile	One representative set per proposed grading before production One set every 100 yd ³ (Min. 1 set per month)
Organic Impurities	AASHTO T 21	Stockpile	Once per fine aggregate per year**
% Absorption	AASHTO T 84 & T 85	Stockpile	Once per aggregate per year
Specific Gravity	AASHTO T 84 & T 85	Stockpile	Once per aggregate per year
Total Moisture in Aggregate	AASHTO T 255	Stockpile	One set per day's production
Free Water and Aggregate Wt.	N/A		One per day's production
% Entrained Air	AASHTO T 152	On Project	On first two loads and every third load thereafter provided consistent results are achieved
Compressive Strength	AASHTO T 22	On Project	One set per subplot
Compressive Strength	AASHTO T 22	On Project	One set per subplot

*Additional QC testing will be required any time a process change occurs during a placement, including changes in type or dosage of admixture. Additional testing shall include, but is not limited to, entrained air testing.

**If the color produced is a laboratory designation Plate III, then the fine aggregate shall be tested once per month

502.1702 Quality Control, Method C Remove this sub section and replace it with:

“The Contractor shall submit a QCP listing the mix design(s) to be used, the name and location of the production facility, a brief description of the placement and curing process and the name and qualifications of any QCT to be used. When a hydration stabilizing admixture is proposed for use, the manufacturer, product name, dosage rate and discharge time, from the time cement is added to the aggregate, shall be included, as well as procedures for monitoring attainment of Accelerated Hydration Gain. A QCT will be required. The Contractor shall provide a Certificate of Compliance for each truckload of concrete to the Department at the time of the load placement.”

502.18, Method of Measurement, Revise Subsection ‘F’ by removing the word ‘transverse’ so that it reads: **“Saw cut grooving of concrete wearing surfaces, complete and accepted, will be measured for payment as one lump sum.”**

502.19, Basis of Payment, Revise the third paragraph by removing the word ‘transverse’ so that it reads: **“Saw cut grooving of concrete wearing surfaces will be paid for at the Contract Lump Sum Price, which shall be payment for furnishing all materials, labor, and equipment, including depth gauges and all incidentals, to satisfactorily complete the work.”**
(Also see 535.24 and 535.25 for related changes)

SECTION 503 REINFORCING STEEL

Section 503.07 Splicing Revise this section by removing the table and following footnote and replacing them with:

Minimum Lap Splice Length (inches)									
Bar Type	Bar Size								
	#3	#4	#5	#6	#7	#8	#9	#10	#11
Plain or Galvanized	16	20	24	29	38	47	59	72	85
Epoxy or Dual Coated	17	24	36	43	56	71	88	107	128
Stainless	19	24	30	36	47	59	73	89	107
Low-carbon Chromium	24	32	39	47	63	78	97	119	142

“The minimum lap splice lengths in the table above are based on the parameters below. When any of these parameters are altered, appropriate minimum lap splice lengths will be as shown on the Plans.

- Normal weight concrete
- Minimum 28-day concrete compressive strength from 4,000 psi to 10,000 psi

- **Class B tension lap splice**
- **Minimum center-to-center spacing between bars of 6 inches**
- **Minimum clear cover of 2 inches**
- **Nominal reinforcing steel yield strengths**
 - **Low-carbon Chromium = 100 ksi**
 - **Stainless = 75 ksi**
 - **All others = 60 ksi**
- **Reinforcement with yield strengths greater than 75 ksi shall have beam transverse reinforcement and column ties provided over the required lap splice length in accordance with the current edition of the AASHTO LRFD Bridge Design Specifications**

When lap splices are placed horizontally in an element where the concrete depth below the splice will be 12 inches, or more, the indicated lap splice lengths shall be multiplied by a factor of 1.3.”

Amend the Paragraph starting with **Welded Splices may be made...**” by adding to the last sentence beginning so that it reads **“The Contractor shall submit complete details of their proposed method of making welded splices for the Resident's approval at least 10 days prior to use.”**

504.12 Protective Coatings Revise this subsection by removing the paragraph beginning with “When galvanizing is specified” and replacing it with:

“When galvanizing is specified, clean the steel in accordance with SSPC-SP 6 prior to galvanizing. Galvanize in accordance with AASHTO M 111 (ASTM A123). Galvanize fasteners in accordance with AASHTO M 232 (ASTM A153), ASTM F2329, or ASTM B695, Class 50, Type I. Galvanized nuts shall be lubricated with a water-soluble lubricant containing a dye that contrasts with the color of the galvanizing.”

SECTION 506 SHOP APPLIED PROTECTIVE COATING – STEEL

506.10 Description Revise this subsection by removing the entire paragraph in its entirety and replacing it with:

“This work shall consist of surface preparation and application of coating systems in accordance with the Plans and this Specification. The color of structural steel painted in its entirety shall comply with SAE AMS-STD-595 – Colors Used in Government Procurement Color No. 14272 (Green), unless otherwise specified in the Contract. The color of partially painted weathering steel shall comply with SAE AMS-STD-595 – Colors Used in Government Procurement Color No. 30045 (Brown), unless otherwise specified in the Contract. All other coating colors shall be as specified in the Contract.”

506.13 Surface Preparation Amend this section by adding this paragraph to the end:

“Steel shall meet the requirements of SSPC SP8 Pickling prior to being immersed in the zinc tanks. Verification of the surface preparation shall be included in the QC documentation.”

SECTION 518 STRUCTURAL CONCRETE REPAIR

518.02 Repair Materials Replace the paragraph beginning with “Where the depth of placement...” with the following:

“Where the depth of placement is equal to or greater than 1 inch, the Contractor may use concrete as the repair material. When concrete is used, the coarse aggregate shall conform to the requirements of the table below and Standard Specification Section 703.02, Coarse Aggregate for Concrete, or 703.03, Combined Aggregate Grading for Concrete.”

Remove the second table with the heading, “Sieve Designation Percent by Weight Passing a Square Mesh Sieve”

SECTION 523 BEARINGS

523.051 Protective Coating Revise this subsection by removing the paragraph beginning with “Anchor rods shall be galvanized...” and replacing with:

“Anchor rods shall be galvanized. When anchor rods are designated to secure bare unpainted steel or painted steel, a dielectric coating (epoxy or bituminous type coatings are acceptable) shall be applied to the anchor rod and/or adjacent steel to prevent contact between galvanized surfaces and painted or unpainted steel.”

523.22 Fabrication Amend this subsection by adding the following: **“Elastomeric Bearings shall be fabricated in accordance with AASHTO M251.”**

SECTION 526 CONCRETE BARRIER

Amend this section by deleting it in its entirety and replacing it with:

“526.01 Description This work shall consist of the furnishing, constructing, erecting, setting, resetting, and removal of concrete barrier and associated elements in accordance with these specifications, the Standard Details, and the lines and grades shown on the Plans or established by the Resident.

The types of concrete barrier are designated as follows:

Portable Concrete Barrier Type I Double faced removable barrier in accordance with the Standard Details.

Permanent Concrete Barrier Type II Double faced barrier as shown on the Plans.

Permanent Concrete Barrier Type IIIa Single faced barrier 32 inches high in accordance with the Standard Details or as shown on the Plans.

Permanent Concrete Barrier Type IIIb Single faced barrier 42 inches high in accordance with the Standard Details or as shown on the Plans.

Permanent Concrete Transition Barrier Barrier of various heights joining steel bridge rail to steel guardrail in accordance with the Standard Details or as shown on the Plans.

Permanent Texas Classic Rail Barrier Traffic rail or sidewalk rail, in accordance with the Standard Details or as shown on the Plans.

526.02 Materials

a. **Concrete** Concrete for barriers, both permanent and portable, shall have a design strength of 5,000 psi.

For cast-in-place barrier: The concrete shall be Class LP, in accordance with Standard Specification Section 502, Structural Concrete.

For precast barrier: The concrete shall meet the requirements of Standard Specification 712.061, Structural Precast Concrete Units, except that the stripping strength for precast barriers is 4,000 psi.

b. **Reinforcing Steel** Reinforcing steel shall meet the requirements of Section 503, Reinforcing Steel.

c. **Structural Steel** Plates and barrier connections shall meet the requirements specified in Standard Specification 504 - Structural Steel and shall be hot dip galvanized after fabrication in accordance with Standard Specification 506, Shop Applied Protective Coating – Steel

d. **Bolts** Bolts shall meet the requirements specified in Section 713.02, High Strength Bolts.

e. **Connecting Pins for Portable Concrete Barrier** Portable concrete barriers must be connected using a 1- inch diameter pin. The connecting pin must be smooth, not deformed, i.e., reinforcing bar may not be used, and shall meet the strength requirements of ASTM A449 steel. Materials with greater strength may be used with the approval of the Department.

f. Anchor Pins for Portable Concrete Barrier Anchoring to concrete or asphalt will be required when specified on the Plans. When required, portable concrete barriers must be anchored using a 1 ½ - inch diameter anchor pin. The anchor pin must be smooth, not deformed, i.e., reinforcing bar may not be used, and shall meet the strength requirements of ASTM A36 steel. Materials with greater strength may be used with the approval of the Department.

g. Device Crashworthiness MaineDOT is transitioning to MASH2016 criteria for Portable Concrete Barrier on the following schedule:

New Portable Concrete Barrier shall be crash tested and/or evaluated to MASH2016 criteria.

Current Portable Concrete Barrier in useful serviceable condition that is successfully tested to NCHRP Report 350 or MASH2009 criteria may be utilized through December 31, 2029.

Other current Portable Concrete Barrier that is deemed acceptable by the Department may be utilized on projects off the National Highway System through December 31, 2024.

526.03 Construction Requirements

Cast-in-place barriers shall be fabricated in accordance with Standard Specification Section 502, Structural Concrete. Precast barriers shall be fabricated in accordance with Standard Specification 534, Precast Structural Concrete.

Concrete finish for permanent barrier shall be rubbed as defined in Standard Specification Section 502, Structural Concrete, 502.13 D2 or an approved equal.

Portable concrete barrier shall be generally free from fins and porous areas and shall present a neat and uniform appearance.

Permanent barrier shall have a protective coating applied in accordance with Standard Specification Section 515, Protective Coating for Concrete Surfaces.

Reflective delineators for concrete median barrier shall meet the requirements of Special Provision 645, Highway Signing.

Preformed Joint Filler shall meet the requirements specified in Subsection 705.01, Preformed Expansion Joint Filler.

Permissible dimensional tolerances for all concrete barriers shall be as follows:

a. Cross-sectional dimensions shall not vary from design dimensions by more than ¼ inch. The vertical centerline shall not be out of plumb by more than ¼ inch.

b. Longitudinal dimensions shall not vary from the design dimensions by more than ¼ inch per 10 feet of barrier section and shall not exceed ¾ inches per section.

c. Location of anchoring holes shall not vary by more than ½ inch from the dimensions shown in the concrete barrier details on the Plans.

d. Surface straightness shall not vary more than ¼ inch under a 10-foot straightedge.

e. The barrier shall have no significant cracking. Significant cracking is defined as fractures or cracks passing through the section, or any continuous crack extending for a length of 12 inches or more, regardless of position in the section.

526.04 Method of Measurement Permanent Concrete Barrier Type II, IIIa, IIIb, Texas Classic Rail, and Precast Median Barrier will be measured for payment by lump sum, complete in place.

Portable concrete barrier, both anchored and unanchored will be measured for payment by lump sum. Lump sum measurement will include verification of the installation and removal of all portable concrete at the completion of the Contractor's operations.

The Contractor shall replace sections of portable concrete barrier, including anchored barrier damaged by the traveling public when directed by the Resident. Replacement sections will be measured for payment in accordance with Standard Specification 109.7, Equitable Adjustments to Compensation and Time.

Transition barrier will be measured by each, complete in place.

526.05 Basis of Payment The accepted quantities of Concrete Barrier Type II, IIIa, IIIb, Texas Classic Rail, and Precast Median Barrier will be paid for at the Contract lump sum price for the type specified, complete in place.

The accepted quantities of Portable Concrete Barrier Type I, both anchored and unanchored will be paid for at the Contract lump sum price. Such payment shall be full compensation for furnishing all materials, assembling, moving, resetting, transporting, temporarily storing, removing barrier, furnishing new parts as necessary, and all incidentals necessary to complete the work.

Portable barrier shall become the property of the Contractor upon completion of the use of the barrier on the project and shall be removed from the project site by the Contractor.

Transition barrier will be paid for at the Contract price each, complete in place.

The accepted quantity of all types of concrete barrier, whether portable or permanent, will be paid for at the lump sum or per each price, as applicable, which payment shall be full compensation for all materials, including reinforcing steel, protective coating, reflective

delineators, steel plates and hardware, equipment, labor and incidentals required, as necessary, to complete the work.

Payment will be made under:

	<u>Pay Item</u>	<u>Pay Unit</u>
526.301	Portable Concrete Barrier, Type I	Lump Sum
526.304	Portable Concrete Barrier, Anchored Type I	Lump Sum
526.312	Permanent Concrete Barrier Type II	Lump Sum
526.321	Permanent Concrete Barrier Type IIIa	Lump Sum
526.323	Texas Classic Rail	Lump Sum
526.331	Permanent Concrete Barrier Type IIIb	Lump Sum
526.34	Permanent Concrete Transition Barrier	Each
526.502	Precast Concrete Median Barrier	Lump Sum”

SECTION 527 ENERGY ABSORBING UNIT

527.02 Materials Amend this section by deleting it in its entirety and replacing it with:

“MaineDOT is transitioning to MASH2016 criteria for Work Zone Traffic Control Devices on the following schedule:

Portable Crash Cushions will be crash tested and/or evaluated to MASH2016 criteria by January 1, 2030. Current Category 3 devices in useful serviceable condition that are successfully tested to NCHRP Report 350 or MASH2009 criteria may be utilized through December 31, 2029.

Work Zone Crash Cushions shall be selected from the Department’s Qualified Products List of Crash Cushions/Impact Attenuators or approved equal.”

SECTION 535 PRECAST, PRESTRESSED CONCRETE SUPERSTRUCTURE

535.02 Materials Replace the description of “Coarse Aggregate for Concrete (Class A, AA, or Latex) in its entirety with: **“Coarse Aggregate for Concrete (Class A, AA, or SP-1-7)”**

535.22 Tolerances Amend this section by deleting it in its entirety and replacing it with:

“Product dimensional tolerances shall be in conformance with the latest edition of PCI MNL-135, Tolerance Manual for Precast and Prestressed Concrete Construction, as applicable to the particular product (e.g., slab, I-girder, box beam), the Plans, and this Specification. Use Box

Beam fabrication tolerances for voided or solid slab beams and use Double Tee tolerances for NEXT beams. In case of dispute, the Fabrication Engineer shall determine the allowable tolerance.”

535.24 Installation of Slabs, Beams, and Girders Revise the 5th paragraph by replacing “6.0 and 9.0” to “5.0 and 8.0” so it reads: **“Ready mixed grout shall achieve a design compressive strength of 6,000 psi at 28 days, have an entrained air content of between 5.0 and 8.0 percent, be non-shrink, flowable, and contain a non-shrink additive listed on the Department QPL for expansive cements.”**

535.25, Installation of Precast/Prestressed Deck Panels Revise the 2nd paragraph by replacing “6.0 and 9.0” to “5.0 and 8.0” so it reads: **“Ready mixed grout shall achieve a design compressive strength of 6,000 psi at 28 days, have an entrained air content of between 5.0 and 8.0 percent, be non-shrink, flowable, and contain a non-shrink additive listed on the Department QPL for expansive cements.”**

SECTION 606 GUARDRAIL

Amend this section by replacing it with the following:

606.01 Description This work shall consist of furnishing and installing guardrail components in accordance with these specifications and in reasonably close conformity with the lines and grades shown on the plans or as established. Guardrail is designated as:

31” W-Beam Guardrail - Mid-Way Splice

Galvanized steel w-beam, 8” wood or composite offset blocks, galvanized steel posts

Thrie Beam

Galvanized steel thrie beam, 8” wood or composite offset blocks, galvanized steel posts

Median guardrail shall consist of two beams of the above types, mounted on single posts.

Bridge mounted guardrail shall consist of furnishing all labor, materials, and equipment necessary to install guardrail as shown on the plans. This work shall also include drilling for and installation of offset blocks if specified, and incidental hardware necessary for satisfactory completion of the work.

Remove and Reset and Remove, Modify, and Reset guardrail shall consist of removing the existing designated guardrail and resetting in a new location as shown on the plans or directed by the Resident. Remove, Modify, and Reset guardrail and Modify guardrail include the following guardrail modifications: Removing plate washers at all posts, except at anchorage assemblies as noted on the Standard Details, adding offset blocks, and other modifications as listed in the Construction Notes or General Notes. Modifications shall conform to the guardrail Standard Details.

Bridge Connection shall consist of the installation and attachment of beam guardrail to the existing bridge. This work shall consist of constructing a concrete end post or modifying an existing end post as required, furnishing, and installing a terminal connector, necessary hardware, and incidentals required to complete the work as shown on the plans. Bridge Transition shall consist of a bridge connection and furnishing and installing guardrail components as shown in the Standard Details.

606.02 Materials Materials shall meet the requirements specified in the following Sections of Division 700 - Materials:

Timber Preservative	708.05
Metal Beam Rail	710.04
Guardrail Posts	710.07
Guardrail Hardware	710.08

Guardrail components shall meet the applicable standards of "A Guide to Standardized Highway Barrier Hardware" prepared and approved by the AASHTO-AGC-ARTBA Joint Cooperative Committee, Task Force 13 Report.

Posts for underdrain delineators shall be "U" channel steel, 8 ft long, 2 ½ lb/ft minimum and have 3/8-inch round holes, 1-inch center to center for a minimum distance of 2 ft from the top of the post.

Reflectorized Flexible Guardrail Markers shall be mounted on all guardrails. A marker shall be mounted onto guardrail posts at the flared guardrail terminal end point and tangent point, both at the leading and trailing ends of each run of guardrail. The marker's flexible posts shall be gray with either silver-white or yellow reflectors (to match the edge line striping) at the tangents, red at leading ends, and green at trailing ends. Whenever the guardrail terminal is not flared, markers will only be required at the terminal end point. These shall be red or green as appropriate. Markers shall be installed on the protected side of guardrail posts unless otherwise approved by the Resident. Reflectorized flexible guardrail markers shall be from the Department's Qualified Products List of Delineators. The marker shall be gray, flexible, durable, and of a non-discoloring material to which 3-inch by 9-inch reflectors shall be applied, and capable of recovering from repeated impacts and meeting MASH 16 requirements. Reflective material shall meet the requirements of Section 719.01 for ASTM D 4956 Type III reflective sheeting. The marker shall be secured to the guardrail post with two fasteners, as shown in the Standard Details.

Reflectorized beam guardrail reflectors shall be mounted on all "w" beam guardrail and shall be either the "butterfly" type or linear delineation system panels. "Butterfly" or linear delineation panels shall be installed at approximately 62.5 foot intervals on tangents (after every tenth post) and 31.25 feet on curves (after every fifth post), and shall be centered on the guardrail beam. On Divided highways, the left-hand delineators shall be yellow and the right-hand delineators shall be silver/ white. On two-way directional highways, the right-hand side will have silver / white reflectors and no reflectorized delineator used on the left. Delineators shall have reflective sheeting that meets or exceeds the requirements of Section 719.01.

“Butterfly” reflectors shall be fabricated from high-impact, ultraviolet & weather resistant thermoplastic. Aluminum, galvanized metal or other materials shall not be used. Reflective sheeting will be applied to only one side of the delineator facing the direction of traffic and shall be centered vertically on the guardrail beam as shown in the Standard Detail 606(7).

Linear delineation system panels shall be 1.5 inches wide by approximately 11 inches nominal length, with a minimum of 5 raised lateral ridges spaced at approximately 2.25 inches. The height of each ridge shall be 0.34 inches with a 45 degree profile and a 0.28 inches radius at the top. Sheeting shall be laminated to thin gauge aluminum with a pre-applied adhesive tape on the back. Panels shall not be installed over seams or bolt heads and shall be centered horizontally on the guardrail beam; linear delineation panels shall be attached to only one guardrail beam. The guardrail beam surface shall be cleaned and prepared according to the manufacturer’s instructions. Air temperature and guardrail surface temperature must be a minimum of 50 degrees F (10 C) with rising temperature at the time of installation.

Exact locations of the either the “butterfly” type or the linear delineation panels shall be approved by the Resident prior to installation.

Single wood post shall be of cedar, white oak, or tamarack, well-seasoned, straight, and sound and have been cut from live trees. The outer and inner bark shall be removed, and all knots trimmed flush with the surface of the post. Posts shall be uniform taper and free of kinks and bends.

Single steel post shall conform to the requirements of Section 710.07 b.

Single steel pipe post shall be galvanized, seamless steel pipe conforming to the requirements of ASTM A120, Schedule No. 40, Standard Weight.

Acceptable multiple mailbox assemblies shall be listed on the Department’s Qualified Products List and shall be MASH 16 tested and approved.

Flared and Tangent w-beam guardrail terminals and guardrail offset blocks shall be from the Department’s Qualified Products List. Flared terminals shall be installed with a 4 ft offset as shown in the Manufacturer’s installation instructions.

Anchorage assemblies used to anchor trailing ends, radius guardrail, or other ends not exposed to traffic shall meet the applicable standards of "A Guide to Standardized Highway Barrier Hardware" prepared and approved by the AASHTO-AGC-ARTBA Joint Cooperative Committee, Task Force 13 Report, Drawing SEW02a.

Existing materials damaged or lost during adjusting, removing and resetting, or removing, modifying, and resetting, shall be replaced by the Contractor without additional compensation. Existing guardrail posts and guardrail beams found to be unfit for reuse shall be replaced when directed by the Resident.

606.03 Posts Posts for guardrail shall be set plumb in holes or they may be driven if suitable driving equipment is used to prevent battering and distorting the post. When posts are driven

through pavement, the damaged area around the post shall be repaired with approved bituminous patching. Damage to lighting and signal conduit and conductors shall be repaired by the Contractor.

When set in holes, posts shall be on a stable foundation and the space around the posts, backfilled in layers with suitable material, thoroughly tamped.

The reflectorized flexible guardrail markers shall be set plumb with the reflective surface facing the oncoming traffic. Markers shall be installed on the protected side of guardrail posts. Markers, which become bent or otherwise damaged, shall be removed and replaced with new markers.

Single wood posts shall be set plumb in holes and backfilled in layers with suitable material, thoroughly tamped. The Resident will designate the elevation and shape of the top. The posts, that are not pressure treated, shall be painted two coats of good quality oil base exterior house paint.

Single steel posts shall be set plumb in holes as specified for single wood posts or they may be driven if suitable driving equipment is used to prevent battering and distorting the post.

Additional bolt holes required in existing posts shall be drilled or punched, but the size of the holes shall not exceed the dimensions given in the Standard Details. Metal around the holes shall be thoroughly cleaned and painted with two coats of approved aluminum rust resistant paint. Holes shall not be burned.

606.04 Rails Brackets and fittings shall be placed and fastened as shown on the plans. Rail beams shall be erected and aligned to provide a smooth, continuous barrier. Beams shall be lapped with the exposed end away from approaching traffic.

End assemblies shall be installed as shown on the plans and shall be securely attached to the rail section and end post.

All bolts shall be of sufficient length to extend beyond the nuts but not more than ½ inch. Nuts shall be drawn tight.

Additional bolt holes required in existing beams shall be drilled or punched, but the size of the holes shall not exceed the dimensions given in the Standard Details. Metal around the holes shall be thoroughly cleaned and painted with two coats of approved aluminum rust resistant paint. Holes shall not be burned.

606.045 Offset Blocks The same offset block material is to be provided for the entire project unless otherwise specified.

606.05 Shoulder Widening At designated locations the existing shoulder of the roadway shall be widened as shown on the plans. All grading, paving, seeding, and other necessary work shall be in accordance with the Specifications for the type work being done.

606.06 Mail Box Post Single wood post shall be installed at the designated location for the support of the mailbox. The multiple mailbox assemblies shall be installed at the designated location in

accordance with the Standard Details and as recommended by the Manufacturer. Attachment of the mailbox to the post will be the responsibility of the home or business owner.

606.07 Abraded Surfaces All galvanized surfaces of new guardrail and posts, which have been abraded so that the base metal is exposed, and the threaded portions of all fittings and fasteners and cut ends of bolts shall be cleaned and painted with two coats of approved rust resistant paint.

606.08 Method of Measurement Guardrail will be measured by the linear foot from center to center of end posts along the gradient of the rail except where end connections are made to masonry or steel structures, in which case measurement will be as shown on the plans. When connected to radius rail, measurement will be to the end of the last tangent beam.

Guardrail terminal, reflectorized flexible guardrail marker, terminal end, anchorage assembly, bridge transition, bridge connection, multiple mailbox post, and single post will be measured by each unit of the kind specified and installed.

Widened shoulder will be measured as a unit of grading within the limits shown on the plans.

Excavation in solid rock for placement of posts will be paid under force account unless otherwise indicated in the Bid Documents.

Reflectorized beam guardrail reflectors (“butterfly” type or linear delineation system panels) when identified by pay item, will be measured for payment by each.

606.09 Basis of Payment The accepted quantities of guardrail will be paid for at the contract unit price per linear foot for the type specified, complete in place. Reflectorized beam guardrail (“butterfly”-type) delineators will not be paid for directly but will be considered incidental to guardrail items. Reflectorized flexible guardrail marker, terminal end, anchorage assembly, bridge transition, bridge connection, multiple mailbox post, and single post will be paid for at the contract unit price each for the kind specified complete in place.

Guardrail terminals will be paid for at the contract price each, complete in place which price shall be full payment for furnishing and installing all components including the terminal section, posts, offset blocks, "w" beam, cable foundation posts, plates and for all incidentals necessary to complete the installation within the limits as shown on the Standard Details or the Manufacturer’s installation instructions. Pay limits for a flared terminal will be 37.5 feet. Pay limits for a tangent terminal will be 50 feet. Each guardrail terminal will be clearly marked with the Manufacturer’s name and model number to facilitate any future needed repair. Such payment shall also be full compensation for furnishing all material, excavating, backfilling holes, assembling, and all incidentals necessary to complete the work, except that for excavation for posts or anchorages in solid ledge rock, payment will be made under 109.7.5 – Force Account. Type III Retroreflective Adhesive Sheeting shall be applied to the approach buffer end sections and sized to substantially cover the end section. On all roadways, the ends shall be marked with alternating black and retroreflective yellow stripes. The stripes shall be 3 in wide and sloped down at an angle of 45 degrees toward the side on which traffic is to pass the end section. Guardrail terminals shall also include a set of installation drawings supplied to the Resident.

Anchorage to bridge end posts will be part of the bridge work. Connections thereto will be considered included in the unit bid price for guardrail.

Guardrail to be placed on a radius of curvature of 150 ft or less will be paid for under the designated radius pay item for the type guardrail being placed.

Widened shoulder will be paid for at the contract unit price each complete in place and will be full compensation for furnishing and placing, grading and compaction of aggregate subbase and any required fill material.

Adjust guardrail will be paid for at the contract unit price per linear foot and will be full compensation for adjusting to grade. Payment shall also include adjusting guardrail terminals where required.

Modify guardrail will be paid for at the contract unit price per linear foot and will be full compensation for furnishing and installing offset blocks, additional posts, and other specified modifications; removing, modifying, installing, and adjusting to grade existing posts and beams; removing plate washers and backup plates, and all incidentals necessary to complete the work. Payment shall also include removing and resetting guardrail terminals where required.

Remove and Reset guardrail will be paid for at the contract unit price per linear foot and will be full compensation for removing, transporting, storing, reassembling all parts, necessary cutting, furnishing new parts when necessary, reinstalling at the new location, and all other incidentals necessary to complete the work. Payment shall also include removing and resetting guardrail terminals when required.

Remove, Modify, and Reset guardrail will be paid for at the contract unit price per foot and will be full compensation for the requirements listed in Modify guardrail and Remove and Reset guardrail.

Bridge Connections will be paid for at the contract unit price each. Payment shall include, attaching the connection to the endpost including furnishing and placing concrete and reinforcing steel necessary to construct new endposts if required, furnishing and installing the terminal connector, and all miscellaneous hardware, labor, equipment, and incidentals necessary to complete the work.

Bridge Transitions will be paid for at the contract unit price each. Payment shall include furnishing and installing the three beam or "w"-beam terminal connector, doubled beam section, and transition section, where called for, posts, hardware, precast concrete transition and vertical curb, and any other necessary materials and labor, including the bridge connection as stated in the previous paragraph.

No payment will be made for guardrail removed, but not reset and all costs for such removal shall be considered incidental to the various contract pay items.

Reflectorized beam guardrail reflectors ("butterfly" type and the linear delineation panels) will not be paid for directly but will be considered incidental to all new guardrail items. The Contractor shall

furnish and install either the “butterfly” type or linear delineation panels, at its discretion, for new guardrail items.

Reflectorized beam guardrail reflectors (either “butterfly” type or linear delineation system panels) will be paid for under the applicable pay items for installation in conjunction with Adjust, Modify, Remove and Reset, Remove Modify and Reset guardrail items. The accepted quantity of “butterfly” type or linear delineation system panels will be paid for at the contract unit price each for all work and materials furnished to install, complete in place, including all incidentals necessary to complete the work.

Payment will be made under:

<u>Pay Item</u>	<u>Pay Unit</u>
606.1301 31” W-Beam Guardrail - Mid-Way Splice – Single Faced	Linear Foot
606.1302 31” W-Beam Guardrail - Mid-Way Splice – Double Faced	Linear Foot
606.1303 31” W-Beam Guardrail - Mid-Way Splice, 15’ Radius and Less	Linear Foot
606.1304 31” W-Beam Guardrail - Mid-Way Splice, Over 15’ Radius	Linear Foot
606.1305 31” W-Beam Guardrail - Mid-Way Splice Flared Terminal	Each
606.1306 31” W-Beam Guardrail - Mid-Way Splice Tangent Terminal	Each
606.1307 Bridge Transition (Asymmetrical) – Type IA	Each
606.1721 Bridge Transition - Type I	Each
606.1722 Bridge Transition - Type II	Each
606.1731 Bridge Connection - Type I	Each
606.1732 Bridge Connection - Type II	Each
606.178 Guardrail Beam	Linear Foot
606.25 Terminal Connector	Each
606.257 Terminal Connector - Thrie Beam	Each
606.259 Anchorage Assembly	Each
606.265 Terminal End-Single Rail - Galvanized Steel	Each
606.266 Terminal End-Single Rail - Corrosion Resistant Steel	Each
606.275 Terminal End-Double Rail - Galvanized Steel	Each
606.276 Terminal End-Double Rail - Corrosion Resistant Steel	Each
606.352 Reflectorized Beam Guardrail Delineators (“Butterfly” type)	Each
606.3521 Linear Delineation System Panel	Each
606.353 Reflectorized Flexible Guardrail Marker	Each
606.354 Remove and Reset Reflectorized Flexible Guardrail Marker	Each
606.356 Underdrain Delineator Post	Each
606.358 Guardrail, Modify	Linear Foot
606.362 Guardrail, Adjust	Linear Foot
606.365 Guardrail, Remove, Modify, and Reset	Linear Foot
606.366 Guardrail, Remove and Reset	Linear Foot
606.367 Replace Unusable Existing Guardrail Posts	Each
606.3671 Replace Unusable Offset Blocks	Each
606.47 Single Wood Post	Each
606.48 Single Galvanized Steel Post	Each

606.50	Single Steel Pipe Post	Each
606.51	Multiple Mailbox Support	Each
606.568	Guardrail, Modify - Double Rail	Linear Foot
606.63	Thrie Beam Rail Beam	Linear Foot
606.64	Guardrail Thrie Beam - Double Rail	Linear Foot
606.65	Guardrail Thrie Beam - Single Rail	Linear Foot
606.66	Terminal End Thrie Beam	Each
606.70	Transition Section - Thrie Beam	Each
606.71	Guardrail Thrie Beam - 15 ft radius and less	Linear Foot
606.72	Guardrail Thrie Beam - over 15 ft radius	Linear Foot
606.73	Guardrail Thrie Beam - Single Rail Bridge Mounted	Linear Foot
606.74	Guardrail - Single Rail Bridge Mounted	Linear Foot
606.753	Widen Shoulder for Low Volume Guardrail End	Each
606.754	Widen Shoulder for Flared Guardrail Terminal	Each
606.78	Low Volume Guardrail End	Each
606.80	Buried-in-Slope Guardrail End	Each

SECTION 608 SIDEWALKS

Section 608.022 Detectable Warning Materials Standard Revise this section by removing the last sentence of this section beginning with “Concrete...” and replacing it with “**Concrete shall meet the requirements of Section 608.021, Sidewalk Materials, of this specification or may be a prepackaged concrete mix from the Department’s Qualified Products List (QPL).**”

SECTION 609 CURB

Remove this section in its entirety and replace with the following:

609.01 Description Construct or reset curb, gutter, or combination curb and gutter, paved ditch, and paved flume. The types of curb are designated as follows:

- Type 1 - Stone curbing of quarried granite stone
- Type 2 – Concrete Curbing
- Type 3 - Bituminous curbing
- Type 5 - Stone edging of quarried granite stone

609.02 Materials Except as provided below, the materials used shall meet the requirements of the following Sections of Division 700 - Materials:

Portland Cement and Portland Pozzolan Cement	701.01
Water	701.02
Air Entraining Chemical Admixture	701.03
Fine Aggregate for Concrete	703.01

Coarse Aggregate for Concrete	703.02
Joint Mortar	705.02
Reinforcing Steel	709.01
Stone Curbing and Edging	712.04
Epoxy Resin	712.35
Hot Mix Asphalt Curbing	712.36
Structural Precast Concrete Units (Concrete Curb)	712.061

The Contractor shall submit a concrete mix design for the Portland Cement Concrete to the Resident, for the uses specified below or in accordance with the Contract Documents.

Circular curb, terminal sections and transition sections shall be in reasonably close conformity with the shape and dimensions shown on the Plans and to the applicable material requirements herein for the type of curb specified.

Dowels shall be reinforcing steel deformed bars.

Concrete for Slipform Concrete Curb shall meet the requirements below:

- a. Class A, with the exception that permeability requirements shall be waived.
- b. Entrained air content of Slipform Concrete Curb shall be 4.0% to 7.0%
- c. Concrete temperature, prior to discharge, shall not exceed 90 F.
- d. Proposed mix designs may contain polypropylene fibers.
- e. Partially discharged loads may be retempered with water provided the maximum water to cement ratio is not exceeded.

609.03 Vertical Stone Curb, Terminal Section and Transition Sections and Portland Cement Concrete Curb, Terminal Sections and Transition Sections

a. Installation The curb stone shall be set on a compacted foundation so that the front top arris line conforms to the lines and grades required. The foundation shall be prepared in advance of setting the stone by grading the proper elevation and shaping to conform as closely as possible to the shape of the bottom of the stone. The required spacing between stones shall be assured by the use of an approved spacing device to provide an open joint between stones of at least ¼ inch and no greater than ⅝ inch.

b. Backfilling All remaining spaces under the curb shall be filled with approved material and thoroughly hand tamped so the stones will have a firm uniform bearing on the foundation for the entire length and width. Any remaining excavated areas surrounding the curb shall be filled to the required grade with approved materials. This material shall be placed in layers not exceeding 8 inches in depth, loose measure and thoroughly tamped.

When backfill material infiltrates through the joints between the stones, small amounts of joint mortar or other approved material shall be placed in the back portion of the joint to prevent such infiltrating.

c. Protection The curb shall be protected and kept in good condition. All exposed surfaces smeared or discolored shall be cleaned and restored to a satisfactory condition or the curb stone removed and replaced.

d. Curb Inlets Curb placed adjacent to curb inlets shall be installed with steel dowels cemented into each stone with epoxy grout as shown in the Standard Details.

The epoxy grout shall be used in accordance with the manufacturer's instructions. The grout shall be forced into the hole, after which the dowel shall be coated with grout for one-half its length and inserted into the grout filled hole. The hole shall be completely filled with grout around the dowel. All tools and containers must be clean before using.

The Contractor may elect to substitute concrete to backfill Stone Curbing or Stone Edging at their option. If the concrete backfill option is elected, the Concrete Fill shall meet the requirements of 609.02. The Contractor shall submit a concrete design for the Portland Cement Concrete, with a minimum designated compressive strength of 3000 PSI meeting the requirements of Class S or Class Fill Concrete. The Contractor may elect to choose a Prepackaged Concrete Mix from the Departments Qualified Products list (QPL). Concrete backfill shall be completed in conformance with a Department supplied concrete backfill detail.

609.04 Bituminous Curb

a. Preparation of Base Before placing the curb, the foundation course shall be thoroughly cleaned of all foreign and objectionable material. String or chalk lines shall be positioned on the prepared base to provide guidelines. The foundation shall be uniformly painted with tack coat at a rate of 0.04 to 0.14 gal/yd².

b. Placing The curb shall be placed by an approved power operated extruding type machine using the shape mold called for. A tight bond shall be obtained between the base and the curb. The Resident may permit the placing of curbing by other than mechanical curb placing machines when short sections or sections with short radii are required. The resulting curbing shall conform in all respects to the curbing produced by the machine.

c. When required, the curb shall be painted and coated with glass beads in accordance with Section 627 - Pavement Marking. Curb designated to be painted shall not be sealed with bituminous sealing compound.

d. Acceptance Curb may be accepted or rejected based on appearance concerning texture, alignment, or both. All damaged curb shall be removed and replaced at the Contractor's expense.

e. Polyester fibers shall be uniformly incorporated into the dry mix at a rate of 0.25 percent of the total batch weight. Certification shall be provided from the supplier with each shipment meeting the following requirements:

Average Length	0.25 inches \pm 0.005
Average Diameter	0.0008 inches \pm 0.0001
Specific Gravity	1.32-1.40
Melting Temperature	480 °F Minimum

609.05 Slipform Concrete Curb

a. Preparation of Base Before placing the curb, the foundation course shall be thoroughly cleaned of all foreign and objectionable material. The Contractor shall not place Slipform Concrete Curb on a wet or frozen foundation. The foundation (HMA or concrete) may be in a Saturated Surface Dry condition, but no standing water shall be allowed. String or chalk lines shall be positioned on the prepared foundation to provide guidelines. Prior to placing the curb, the foundation shall be uniformly coated with an epoxy resin adhesive that meets the requirements of AASHTO M 235, Type I, II, III, IV or V and has been tested by AASHTO Product Evaluation & Audit Solutions. The Contractor shall submit the epoxy resin adhesive that they propose to utilize with the concrete mix design. The epoxy resin adhesive must be approved prior to placement and used in accordance with manufacturer's recommendations.

b. Placing Concrete shall be placed with an approved Slipform machine that will produce a finished product according to the design specified in the Plans. For cold weather slip forming, the outside temperature must be at least 36°F and rising. The curb shall be placed on a firm, uniform foundation, shall conform to the section profile specified in the Plans, and shall match the appropriate grade. Expansion joints shall be placed in the curb where it meets rigid structures such as but not limited to building foundations, catch basin headers or fire hydrants. Contraction joints will be placed at 10-foot intervals using sawing methods, which shall cut 1 to 3 inches into the concrete. Contraction joints shall be cut between 1 and 7 days after placement of the concrete. Joints shall be constructed perpendicular to the subgrade and match other joints in roadways, sidewalks, or other structures when applicable.

c. Curing and Sealing Proper curing shall be provided using either a combination curing/sealing compound spray that meets ASTM 1315 Type 1-Class A, or a curing compound spray that meets ASTM 309 Type 1-D – Class A. Curing may also be accomplished by the methods specified in Standard Specification Section 502.14, Curing Concrete.

If a combination curing/sealing compound spray is not used, a separate sealing compound from the MaineDOT Qualified Products List for a Type 1c sealer shall be applied after the concrete has cured.

d. Protection Slipform curb must be adequately protected after placement. The concrete shall be allowed to cure for at least 72 hours. During cold weather conditions, when temperatures drop below the required temperature of 36°F after placement, curbing shall be protected by concrete blankets or a combination of plastic sheeting and straw. After any

placement of Slipform curb, regardless of weather conditions, the placed curb shall be adequately protected by traffic control devices as necessary.

e. Marking When required, the curb shall be painted and coated with glass beads in accordance with Section 627 - Pavement Marking. Curb designated to be painted shall not be sealed unless a combination curing/sealing compound is used.

f. Acceptance Curb shall be accepted or rejected based on finish, alignment, entrained air content, and compressive strength. Concrete Quality Control and Acceptance shall be done in accordance with Standard Specification Section 502, Method C. All damaged curb shall be removed and replaced at the Contractor's expense.

609.06 Stone Edging The curb shall be installed, backfilled and protected in accordance with Section 609.03, except as follows:

a. Slope The edging shall be set on a slope as shown on the Plans or as directed.

b. Joints Joints shall be open and not greater than 1½ inch in width.

609.07 Stone Bridge Curb

a. Installation Each stone and the bed upon which it is to be placed shall be cleaned and thoroughly wetted with water before placing the mortar for bedding and setting the stone. The stone shall be set on a fresh bed of joint mortar and well bedded before the mortar has set so that the front top arris line conforms to the line and grade required. Whenever temporary supporting wedges or other devices are used in setting the stones, they shall be removed before the mortar in the bed has become set, and the holes left by them shall be filled with mortar. Concrete behind the stones shall not be placed until the stones have been in place at least two days. Bedding and pointing mortar for joints shall be cured as required under Section 502 - Structural Concrete.

b. Joints Vertical joints shall be ½ inch in width plus or minus ⅛ inch. Whenever possible, the face and top of the joint shall be pointed with joint mortar to a depth of 1½ inch, before the bedding mortar has set. Joints which cannot be so pointed, shall be prepared for pointing by raking them to a depth of 1½ inch before the mortar has set. Joints not pointed at the time the stone is laid shall be thoroughly wetted with clean water and filled with mortar. The mortar shall be well driven into the joint and finished with an approved pointing tool, flush with the pitch line of the stones.

609.08 Resetting Stone or Portland Cement Concrete Curb, Including Terminal Sections and Transitions

The curb shall be installed, backfilled and protected in accordance with Section 609.03, except as follows:

a. Removal of Curbing The Contractor shall carefully remove and store curb specified on the Plans or designated for resetting. Curb damaged or destroyed, because of the

Contractor's operations or because of their failure to store and protect it in a manner that would prevent its loss or damage, shall be replaced with curbing of equal quality at the Contractor's expense.

b. Cutting and Fitting Cutting or fitting necessary in order to install the curbing at the locations directed shall be done by the Contractor.

609.09 Method of Measurement Curb, both new and reset, will be measured by the linear foot along the front face of the curb at the elevation of the finished pavement, complete in place and accepted. Curb inlets at catch basins, including doweling, will not be measured for payment but shall be considered included in the cost of the catch basin. New transition sections and terminal curb will be measured by the unit. Reset transition sections and terminal curb will be included in the measurement for resetting curb.

Concrete Slipform Curb and terminal ends will be measured by the linear foot along the front face of the curb at the elevation of the finished pavement, complete in place and accepted.

609.10 Basis of Payment The accepted quantities of curbing will be paid for at the contract unit price per linear foot for each kind and type of curbing as specified.

Payment for terminal curb shall include only that portion of the curbing modified for installation at ends of curb runs shown in the Standard Details. Curb adjacent to terminal ends shall be paid for at the contract unit price per linear foot for the type of curb installed.

Vertical Curb Type 1 is required to have a radius of 60 feet or less, will be paid for as Vertical Curb Type 1 - Circular.

Curb, Type 5 required to have a radius of 30 feet or less will be paid for as Curb Type 5 - Circular.

There will be no separate payment for concrete fill, mortar, reinforcing steel, anchors, tack coat, drilling for and grouting anchors, pointing and bedding of curbing, and for cutting and fitting, but these will be considered included in the work of the related curb.

Removal of existing curb and necessary excavation for installing new or reset curbing will not be paid for directly but shall be considered to be included in the appropriate new or reset curb pay item. Base and Subbase material will be paid for under Section 304 - Aggregate Base and Subbase Course. Backing up bituminous curb is incidental to the curb items. Loam, as directed, will be paid under 615 – Loam.

SECTION 619
MULCH

619.03 General Amend this Section by adding the following sentence to the end: **“Straw mulch shall be used in all wetland areas.”**

SECTION 626
FOUNDATIONS, CONDUIT, AND JUNCTION BOXES FOR HIGHWAY
SIGNING, LIGHTING, AND SIGNALS

Section 626.021 Miscellaneous Materials Revise this section by removing the fourth paragraph beginning with “ All Concrete for concrete encasement...” and replace it with **“All concrete for concrete encasement of conduit shall be Class S or Class Fill concrete in accordance with the applicable requirements of Section 502 – Structural Concrete, or a Prepackaged Concrete Mix from the Department’s Qualified Products List (QPL).”**

Section 626.031 Conduit Revise the fifth paragraph beginning with “After the trench has been...” by removing the last sentence beginning with “Where concrete encasement...” and replacing it with **“Where concrete encasement is required around the conduit, the concrete shall meet Class S, Class Fill in accordance with the applicable requirements of Section 502 – Structural Concrete, or a Prepackaged Concrete Mix from the Department’s Qualified Products List (QPL).”**

626.034 Concrete Foundations Revise this Section by changing ‘626.037’ to ‘**626.036**’ in the Second Paragraph which begins with “Foundations shall consist of cast-in-place...”.

Revise the 10th paragraph beginning with “Before placing concrete, the required elbows...” by removing **“...in accordance with Standard Specification 633.”**

626.036 Precast Foundations Revise the last sentence of paragraph one so that it reads: **“Construction of precast foundations shall conform to the Standard Details and all requirements of 712.061.”**

SECTION 627
PAVEMENT MARKINGS

627.02 Materials Amend this section by adding the following to the existing Specification:

“When pavement marking paint must be applied on pavement with an air temperature between 35 °F and 50 °F, a low temperature waterborne paint may be used upon the Department’s approval as noted below.

The Contractor shall submit the following information for Department review and approval at least 10 calendar days prior to application:

The manufacturer and product name of the low temperature waterborne paint

The manufacturer's technical product data sheets

The product's SDS sheets

All required and recommended application specifications for the product

The manufacturer's requirements for temperature, surface preparation, paint thickness and the bead application shall be followed. No additional payment will be made for the use of low temperature waterborne paint. “

627.06 Application Revise this subsection by replacing the paragraph beginning with “ On other final pavement markings...” with the following:

“On other final pavement markings and on curb, where the paint is applied by hand painting or spraying, application shall be one uniform covering coat at least 16 mils thick. Before the paint has dried, the glass beads shall be applied by a pressure system that will force the glass beads onto the undried paint as uniformly as possible.

Painted lines and markings shall be applied in accordance with the manufacturer's published recommendations. These recommendations will be supplied to the Resident prior to installation.”

Revise this subsection by replacing the paragraph beginning with “ If the final reflectivity values are less...” with the following:

“The final reflectivity will be acceptable if 90 percent or more of the painted pavement lines and markings meet the specified minimum value. If less than 90 percent of the painted pavement lines and markings meet the specified minimum final reflectivity values, the Contractor shall repaint those areas not meeting required reflectivity at no cost to the Department.

If, after repainting, analysis of the final reflectivity values results in the need for a second repainting, the Contractor will submit in writing a plan of action to meet the reflectivity minimums prior to continuing any work. Once the plan has been reviewed and approved by the Department, the Contractor shall reapply at no cost to the Department.”

SECTION 634 HIGHWAY LIGHTING

634.021 Materials Revise this subsection by removing the paragraph beginning with “All bolts for mounting lighting fixtures” and replacing with:

“All bolts for mounting lighting fixtures under bridge structures shall conform to the requirements of ASTM A307. These bolts and other fastening hardware shall be galvanized in

accordance with AASHTO M 232 (ASTM A153), ASTM F2329, or ASTM B695, Class 50, Type I.”

SECTION 637
DUST CONTROL

Revise this section by removing it in its entirety.

SECTION 643
TRAFFIC SIGNALS

643.021 Materials Amend this subsection by adding the following at the end:

“MaineDOT is transitioning to MASH2016 criteria for Work Zone Traffic Control Devices on the following schedule:

Temporary Traffic Control Signals will be crash tested and/or evaluated to MASH2016 criteria by January 1, 2030. Current Category 4 devices in useful serviceable condition that are successfully tested to NCHRP Report 350 or MASH2009 criteria may be utilized through December 31, 2029.”

643.023 Traffic Signal Structures Remove the third paragraph and replace it with the following:

“Traffic signal support structures shall be classified as Fatigue Category III if they are located on roads with a speed limit of 35 mph or less, Fatigue Category II if they are located on roads with a speed limit of greater than 35 mph, and Fatigue Category I if noted on the Contract Plans. Fatigue Importance Factors shall be as specified in Table 11.6-1 (Fatigue Importance Factors). Fatigue analyses are not required for span-wire (strain) pole traffic signal support structures with heights of 55 feet or less unless required by the current edition of AASHTO “LRFD Specifications for Structural Supports for Highway Signs, Luminaires, and Traffic Signals”.

643.09 Service Connection Revise this subsection by removing the paragraph that begins with “Traffic signal services shall have...”.

And by removing the paragraphs beginning with “ A service ground rod shall be installed...” and “A total of 4, 10’ service...” and replace them with **“A total of 4, 10’ service ground rods shall be installed and properly connected together on the outside of the cabinet foundation. One ground rod shall be located at each corner and shall be either flush or slightly below finished grade. The connection between the ground rod and the ground wire shall be an**

exothermic connection such as a Cadweld. The ground wire from the interconnected ground rods shall be routed through a conduit in the foundation and into the base of the cabinet”.

SECTION 645 HIGHWAY SIGNING

Section 645.023 Sign Support Structures. Under letter “c.”, revise the fifth paragraph beginning with “In addition to the required details...” by removing the words **”and foundation”** from the 5th sentence.

Section 645.08 Method of Measurement. Revise the second paragraph beginning with “Bridge-type, cantilever and...” by removing the words **”including the foundation”** .

Section 645.09 Basis of Payment. Revise the third paragraph beginning with “The accepted bridge-type, cantilever and...” by removing the word **”foundation”** from the second sentence. Add the following sentence to the end of the paragraph **“Conduits, Junction Boxes, and Foundations will be paid for under Section 626.”**

SECTION 652 MAINTENANCE OF TRAFFIC

652.2.5 Portable Changeable Message Sign Revise the fifth paragraph so it reads:

“The control system shall include a display screen upon which messages can be reviewed before being displayed on the message sign. The control system shall be capable of maintaining memory when power is unavailable. Messages must be changeable with either a portable electronic device like a notebook computer or an on-board keypad. The controller shall have the capability to store a minimum of 200 user-defined and 200 pre-programmed messages. Controller and battery compartments shall be enclosed in lockable, weather-tight boxes. The cabinet shall be locked at all times that the Contractor is not actively changing the message. The Contractor shall change the password for the controller prior to stationing the PCMS and shall provide the password to the Resident. The password shall be unique per PCMS and secure and shall not be written anywhere in, on, around, or stored in the PCMS.”

Amend this Section by adding the following new subsection:

“652.2.6 Device Crashworthiness MaineDOT is transitioning to MASH2016 criteria for Work Zone Traffic Control Devices on the following schedule:

Category 1 (Cones, Drums, Tubular Markers, Flexible Delineators, and similar devices that have little chance if causing windshield penetration, tire damage, or other significant effect on the control or trajectory of a vehicle) – All Category 1 devices will be manufacturer self-certified as MASH2016 by January 1, 2025. Current Category 1 devices in useful serviceable condition that are not self-certified as MASH2016 compliant may be utilized through December 31, 2024.

Category 2 (Barricades, Portable Sign Supports, Category 1 devices with attachments, and similar devices that are not expected to produce significant vehicular velocity change but may be otherwise hazardous) – All Category 2 devices will be crash tested and/or evaluated to MASH2016 criteria by January 1, 2025. Current Category 2 devices in useful serviceable condition that are successfully tested to NCHRP Report 350 or MASH2009 criteria may be utilized through December 31, 2024.

Category 3 (Portable Concrete Barrier, Portable Crash Cushions, Truck Mounted Attenuators, Category 2 devices weighing more than 100 pounds, and similar devices that are expected to produce significant vehicular velocity change or other harmful reactions) – All Category 3 devices will be crash tested and/or evaluated to MASH2016 criteria by January 1, 2030. Current Category 3 devices in useful serviceable condition that are successfully tested to NCHRP Report 350 or MASH2009 criteria may be utilized through December 31, 2029. (See Standard Specification 526 for additional Portable Concrete Barrier information).

Category 4 (Trailer Mounted Devices: Arrow Boards, Temporary Traffic Control Signals, Area Lighting, Portable Changeable Message Sign, and other similar devices.) – All Category 4 devices will be crash tested and/or evaluated to MASH2016 criteria by January 1, 2030. Current Category 4 devices in useful serviceable condition that are successfully tested to NCHRP Report 350 or MASH2009 criteria may be utilized through December 31, 2029.”

652.3.3 Submittal of Traffic Control Plan Amend this section by adding:

“n. A security plan for any PCMS shall be included. The Contractor shall provide a plan for secure access to the PCMS and protection from unauthorized users. The plan shall have details on securing the cabinets via a lock and password from unauthorized users, password changing protocols, and where the access information will be kept so it can be used in the event of emergency. The Contractor shall not Identify or store passwords in the TCP.”

652.4 Flaggers Revise the first paragraph of this section so that it reads:

“The Contractor shall furnish flaggers as required by the TCP or as otherwise specified by the Resident. All flaggers must have successfully completed a flagger test approved by the Department and administered by a Department-approved Flagger-Certifier who is employing that flagger. All flaggers must carry an official certification card with them while flagging that has been issued by their employer.”

SECTION 681

PRECAST AGGREGATE-FILLED, CONCRETE BLOCK GRAVITY WALL

681.08 Basis of Payment Amend this section by adding the Item Number “**681.10**” in front of the item “Precast Aggregate-Filled Concrete Block Gravity Wall” at the end of the section.

SECTION 701
STRUCTURAL CONCRETE RELATED MATERIAL

701.01 Portland Cement and Portland Pozzolan Cement Amend the first sentence of Paragraph 3 by adding “**or Type 1L Portland Limestone cement**” so that it reads:

“A Type IP (MS) Portland-pozzolan cement (blended hydraulic cement with moderate sulfate resistance) or Type 1L Portland Limestone cement meeting the requirements of AASHTO M 240, may be used instead of Type II or where Type I Portland cement, meeting the requirements of AASHTO M 85, is allowed.”

SECTION 703
AGGREGATES

Add the following to Section 703 - Aggregates

703.01 Fine Aggregate for Concrete Fine aggregate for concrete shall consist of natural sand or, when approved by the Resident, other inert materials with similar characteristics or combinations thereof, having strong, durable particles. Fine aggregate from different sources of supply shall not be mixed or stored in the same pile nor used alternately in the same class of construction or mix without permission of the Resident.

All fine aggregate shall be free from injurious amounts of organic impurities. Should the fine aggregate, when subjected to the colorimetric test for organic impurities, AASHTO T 21, produce a color darker than the reference standard color solution (laboratory designation Plate III), the fine aggregate shall be rejected.

Fine aggregate shall have a sand equivalent value of not less than 75 when tested in accordance with AASHTO T 176.

Fine aggregate sources shall meet the Alkali Silica Reactivity (ASR) requirements of Section 703.0201.

The fineness modulus shall not be less than 2.26 or more than 3.14. If this value is exceeded, the fine aggregate will be rejected unless suitable adjustments are made in proportions of coarse and fine aggregate. The fineness modulus of fine aggregate shall be determined by adding the cumulative percentages of material by weight retained on the following sieves: Nos. 4, 8, 16, 30, 50, 100 and dividing by 100.

Fine aggregate, from an individual source when tested for absorption as specified in AASHTO T 84, shall show an absorption of not more than 2.3 percent.

Sieve Designation	Percentage by Weight Passing Square Mesh Sieves
3/8 inch	100
No. 4	95-100
No. 8	80-100
No. 16	50-85
No. 30	25-60
No. 50	10-30
No. 100	2-10
No. 200	0-5.0

703.02 Coarse Aggregate for Concrete Coarse aggregate for concrete shall consist of crushed stone or gravel having hard, strong, durable pieces, free from adherent coatings and of which the composite blend retained on the 3/8 inch sieve shall contain no more than 15 percent, by weight of flat and elongated particles when performed in accordance with test method ASTM D 4791, Flat Particles, Elongated Particles, or Flat and Elongated Particles in Coarse Aggregate, using a dimensional ratio of 1:5.

The coarse aggregate from an individual source shall have an absorption no greater than 2.0 percent by weight determined in accordance with AASHTO T 85 modified for weight of sample.

The composite blend shall have a Micro-Deval value of 18.0 percent or less as determined by AASHTO T 327 or not exceed 40 percent loss as determined by AASHTO T 96.

Coarse aggregate sources shall meet the Alkali Silica Reactivity (ASR) requirements of Section 703.0201.

Coarse aggregate shall conform to the requirements of the following table for the size or sizes designated and shall be well graded between the limits specified.

Sieve Designation	Percentage by Weight Passing Square Mesh Sieves						
	S	A	AA	SP-1-7	SP-1-78	SP-2-8	SP-2-89
Aggregate Size	1 ½ inch	1 inch	¾ inch	½ inch	½ inch	⅜ inch	⅜ inch
2 inch	100						
1 ½ inch	95-100	100					
1 inch	-	95-100	100				
¾ inch	35-70	-	90-100	100	100		
½ inch	-	25-60	-	90-100	90-100	100	100
⅜ inch	10-30	-	20-55	40-70	40-75	85-100	90-100
No. 4	0-5	0-10	0-10	0-15	5-25	10-30	20-55
No. 8	-	0-5	0-5	0-5	0-10	0-10	5-30
No. 16	-	-	-	-	0-5	0-5	0-10
No. 50	-	-	-	-	-	-	0-5
No. 200*	0-1.5	0-1.5	0-1.5	0-1.5	0-1.5	0-1.5	0-1.5

*This limit will be 0-2.0 for Department production samples. Yearly quality samples will be held to 0-1.5.

703.0201 Alkali Silica Reactive Aggregates All coarse and fine aggregates proposed for use in concrete shall be tested for Alkali Silica Reactivity (ASR) potential under AASHTO T 303 (ASTM C 1260), Accelerated Detection of Potentially Deleterious Expansion of Mortar Bars Due to Alkali-Silica Reaction, prior to being accepted for use. Acceptance will be based on testing performed by an accredited independent lab submitted to the Department. Aggregate submittals will be required on a 5-year cycle, unless the source or character of the aggregate in question has changed within 5 years from the last test date.

As per AASHTO T 303 (ASTM C 1260): Use of a particular coarse or fine aggregate will be allowed with no restrictions when the mortar bars made with this aggregate expand less than or equal to 0.10 percent at 30 days from casting. Use of a particular coarse or fine aggregate will be classified as potentially reactive when the mortar bars made with this aggregate expand greater than 0.10 percent at 30 days from casting. Use of this aggregate will only be allowed with the use of cement-pozzolan blends and/or chemical admixtures that result in mortar bar expansion of less than 0.10 percent at 30 days from casting as tested under ASTM C 1567.

Acceptable pozzolans and chemical admixtures that may be used when an aggregate is classified as potentially reactive include, but are not limited to the following:

- a. Class F Coal Fly Ash meeting the requirements of AASHTO M 295
- b. Ground Granulated Blast Furnace Slag (Grade 100 or 120) meeting the requirements of AASHTO M 302
- c. Densified Silica Fume meeting the requirements of AASHTO M 307
- d. Lithium-based admixtures
- e. Metakaolin

Pozzolans or chemical admixtures required to offset the effects of potentially reactive aggregates will be incorporated into the concrete at no additional cost to the Department.

Amend this section by adding the new sub section:

“703.03 Combined Aggregate Grading for Concrete The combined gradation of the fine and coarse aggregates when mathematically blended using the mix design percentages shall conform to the requirements of the following table for the size or sizes designated and shall be well graded between the limits specified.

Sieve Designation	Percentage by Weight Passing Square Mesh Sieves						
	Grading	S	A	AA	SP-1-7	SP-1-78	SP-2-8
Aggregate Size	1½ inch	1 inch	¾ inch	½ inch	½ inch	⅜ inch	⅜ inch
2 inch	100						
1½ inch	95–100	100					
1 inch	80–100	95–100	100				
¾ inch	55–90	90–100	93–100	100	100		
½ inch	45–80	55–80	60–90	90–100	90–100	100	100
⅜ inch	40–65	40–65	50–80	55–85	65–90	90–100	90–100
No. 4	35–55	35–55	35–60	30–60	40–70	45–75	50–80
No. 8	25–53	28–50	30–55	25–55	30–65	35–65	35–75
No. 16	15–40	18–45	19–45	18–50	20–55	20–55	20–55
No. 30	7–30	9–30	10–33	8–32	10–38	10–38	10–40
No. 50	3–14	4–14	4–16	3–16	4–20	4–20	4–20
No. 100	0–6	0–6	0–6	0–6	0–7	0–8	0–8
No. 200	0–3.5*	0–3.5*	0–3.5*	0–3.5*	0–3.5*	0–3.5*	0–3.5*

***The percent passing the No. 200 sieve shall not exceed 6.0 percent for any fine aggregate. The percent passing the No. 200 sieve shall not exceed 2.0 percent for any single coarse aggregate. The percent passing the No. 200 sieve shall not exceed 4.0 percent for the combined gradation of self-consolidating concrete (SCC) mix designs.”**

703.05 Aggregate for Sand Leveling Aggregate for sand leveling shall be sand of hard durable particles free from vegetable matter, lumps or balls of clay and other deleterious substances. The aggregate shall meet the grading requirements of the following table.

Sieve Designation	Percentage by Weight Passing Square Mesh Sieves
⅜ inch	85-100
No. 200	0-5.0

703.06 Aggregate for Base and Subbase The following shall apply to Sections (a.) and (c.) below. The material shall have a Micro-Deval value of 25.0 or less as determined by AASHTO T 327. If the Micro- Deval value exceeds 25.0, the Washington State Degradation DOT Test Method T113, Method of Test for Determination of Degradation Value (January 2009 version) shall be performed, except that the test shall be performed on the portion of the sample that passes the ½ in sieve and is retained on the No. 10 sieve. If the material has a Washington Degradation value of less than 15, the material shall be rejected. The material used in Section (b.) below shall have a Micro-Deval value of 25.0 or less as determined by AASHTO T 327. If the Micro-Deval value exceeds 25.0 the material may be used if it does not exceed 25 percent loss on AASHTO T 96, Resistance to Degradation of Small-Size Coarse Aggregate by Abrasion and Impact in the Los Angeles Machine.

Recycled Asphalt Pavement (RAP) shall not be used for or blended with aggregate base or subbase.

- a. Aggregate for base, Type A and B shall be crushed ledge or crushed gravel of hard durable particles free from vegetable matter, lumps or balls of clay and other deleterious substances. The gradation of the part that passes a 3 inch sieve shall meet the grading requirements of the following table:

Sieve Designation	Percentage by Weight Passing Square Mesh Sieves	
	Type A	Type B
½ inch	45-70	35-75
¼ inch	30-55	25-60
No. 40	0-20	0-25
No. 200	0-6.0	0-6.0

At least 50 percent by weight of the material retained on the No. 4 sieve shall have at least one fractured face as tested by AASHTO T 335.

Type A aggregate for base shall only contain particles of rock that will pass the 2 inch square mesh sieve.

Type B aggregate for base shall only contain particles of rock that will pass the 4 inch square mesh sieve.

- b. Aggregate for base, Type C shall be crushed ledge or crushed gravel of hard durable particles free from vegetable matter, lumps or balls of clay and other deleterious substances. The material shall meet the grading requirements of the following table:

Sieve Designation	Percentage by Weight Passing Square Mesh Sieves	
	Type C	
4 inches	100	
3 inches	90-100	
2 inches	75-100	
1 inch	50-80	
½ inch	30-60	
No. 4	15-40	
No. 200	0-6.0	

At least 50 percent by weight of the material coarser than the No. 4 sieve shall have at least one fractured face as tested by AASHTO T 335.

c. Aggregate for subbase shall be sand or gravel of hard durable particles free from vegetable matter, lumps or balls of clay and other deleterious substances. The gradation of the part that passes a 3 inch sieve shall meet the grading requirements of the following table:

Sieve Designation	Percentage by Weight Passing Square Mesh Sieves	
	Type D	Type E
½ in	35-80	
¼ inch	25-65	25-100
No. 40	0-30	0-50
No. 200	0-7.0	0-7.0

Type D aggregate for subbase gravel may contain up to 50 percent by weight Recycled Concrete Aggregate (RCA). When RCA is used, the portion of the resulting blend of gravel and RCA retained on a ½” square mesh sieve shall contain a total of no more than 5 percent by weight of other recycled materials such as brick, concrete masonry block, or asphalt pavement as determined by visual inspection.

RCA shall be substantially free of wood, metal, plaster, and gypsum board as defined in Note 9 in Section 7.4 of AASHTO M 319. RCA shall also be free of all substances that fall under the category of solid waste or hazardous materials.

Aggregate for subbase shall not contain particles of rock which will not pass the 6 inch square mesh sieve.

703.08 Recycled Asphalt Pavement Recycled asphalt pavement shall consist of salvaged asphalt materials from milled pavements or production waste that has been processed before use to meet the requirements of the job mix formula. It shall be free of winter sand, granular fill, construction debris, or other materials not generally considered asphalt pavement.

703.081 RAP for Asphalt Pavement Recycled Asphalt Pavement (RAP) may be introduced into hot-mix asphalt pavement at percentages approved by the Department according to the MaineDOT Policies and Procedures for HMA Sampling and Testing.

If approved by the Department, the Contractor shall provide documentation stating the source, test results for average residual asphalt content, and stockpile gradations showing RAP materials have been sized to meet the maximum aggregate size requirements of each mix designation. The Department will obtain samples for verification and approval prior to its use.

The maximum allowable percent of RAP shall be determined by the asphalt content, the percent passing the 0.075 mm sieve, the ratio between the percent passing the 0.075 mm sieve and the asphalt content, and Coarse Micro-Deval loss values as tested by the Department.

The maximum percentage of RAP allowable shall be the lowest percentage as determined according to Table 4 below:

Classification	Maximum RAP Percentage Allowed	Asphalt content standard deviation	Percent passing 0.075 mm sieve standard deviation	Percent passing 0.075 mm sieve / asphalt content ratio	Residual aggregate M-D loss value
Class III	10%	≤ 1.0	N/A	≤ 4.0	≤ 18
Class II	20%	≤ 0.5	≤ 1.0	≤ 2.8	
Class I	30%	≤ 0.3	≤ 0.5	≤ 1.8	

Table 4: Maximum Percent RAP According to Test Results

The Department will monitor RAP asphalt content and gradation during production by testing samples from the stockpile at approximately 15,000 T intervals (in terms of mix production). The allowable variance limits (from the numerical average values used for mix designs) for this testing are determined based upon the maximum allowable RAP percentage and are shown below in Table 5.

Table 5: RAP Verification Limits

Classification	Asphalt content (compared to aim)	Percent passing 0.075 mm sieve (compared to aim)
Class III	± 1.5	± 2.0
Class II	± 1.0	± 1.5
Class I	± 0.5	± 0.7

For specification purposes, RAP will be categorized as follows:

Class III – A maximum of 10.0 percent of Class III RAP may be used in any base, intermediate base, surface, or shim mixture. A maximum of 20.0 percent of Class III RAP may be used in hand-placed mixes for item 403.209.

Class II – A maximum of 20.0 percent Class II RAP in any base, binder, surface, or shim course.

Class I – A maximum of 20.0 percent Class I RAP may be used in any base, intermediate base, surface, or shim mixture without requiring a change to the specified asphalt binder. A maximum of 30.0 percent Class I RAP may be used in in any base or intermediate base mixture provided that a PG 58-28 or PG 58-34 asphalt binder is used. A maximum of 30.0 percent Class I RAP may be used in any surface or shim mixture provided that PG 58-34 asphalt binder is used. Mixtures exceeding 20.0 percent Class I RAP must be evaluated and approved by the Department.

The Contractor may use up to two different RAP sources in any one mix design. The total RAP percentage of the mix shall not exceed the maximum allowed for the highest classification RAP source used (i.e. if a Class I & Class III used, total RAP must not exceed 30.0%). The blended RAP material must meet all the requirements of the classification for which the RAP is entered (i.e. 10% Class III with 20% Class I, blend must meet Class I criteria). The Department may take belt cuts of the blended RAP to verify the material meets these requirements. If the Contractor elects to use more than one RAP source in a design, the Contractor shall provide an acceptable point of sampling blended RAP material from the feed belt.

In the event that RAP source or properties change, the Contractor shall notify the Department of the change and submit new documentation stating the new source or properties a minimum of 72 hours prior to the change to allow for obtaining new samples and approval.

Revise this Section by removing 703.7 and 703.9 in its entirety and replace with the following:

703.07 Aggregates for HMA Pavements Coarse and fine aggregate for hot mix asphalt pavements shall be of such gradation that when combined in the proper proportions, including filler, if required, the resultant blend will meet the composition of mixture for the type of pavement specified.

Coarse aggregate, that material retained on the No. 4 sieve, shall be crushed stone or crushed gravel and, unless otherwise stipulated, shall consist of clean, tough, durable fragments free from an excess of soft or disintegrated pieces and free from stone coated with dirt or other objectionable matter. Coarse aggregate shall not exceed an absorption of 2.0 percent by weight as determined by AASHTO T 85.

Fine aggregate, material that passes the No. 4 sieve, shall consist of natural sand, manufactured sand, or a combination of these. It shall consist of hard, tough grains, free from injurious amounts of clay, loam, or other deleterious substances. Fine aggregate shall not exceed an absorption of 2.3 percent by weight as determined by AASHTO T 84.

All individual aggregates for hot mix asphalt pavements shall meet Table 3 requirements (excluding LCP) unless otherwise noted. The Department reserves the right to sample and test the aggregate for any of the following properties at any time:

TABLE 3: Aggregate Consensus Properties Criteria

Estimated Traffic, Million 18 kip ESALs	AASHTO T 335 (minimum %)	AASHTO T 304 Method A **	ASTM D 4791 Method B	AASHTO T 176	Aggregate shall meet at least one of these:		
					AASHTO T 327	AASHTO T 96	WSDOT T 113*
< 3.0	75/60	≥ 40%	≤ 10%	≥ 45	≤ 18.0%	≤ 40%	≥ 30
3.0 to < 10	90/80	≥ 45%		≥ 50		≤ 35%	
≥ 10	95/90					≤ 30%	N/A

* As determined by Washington State DOT Test Method T 113, Method of Test for Determination of Degradation Value except that the reported degradation value will be the result of testing a single composite specimen from that portion of the sample that passes the ½ inch sieve and is retained on the No. 10 sieve.

** Property will be evaluated on a mix design basis by calculating a weighted average based upon individual aggregate values (weighted average by the percentage proportion of the aggregate within the design).

AASHTO T 335 - “90/80” denotes that 90 percent of the coarse aggregate has one fractured face and 80 percent has two fractured faces.

AASHTO T 304 - Criteria are presented as percent air voids in loosely compacted fine aggregate, (U).

ASTM D4791 - Criteria are presented as maximum percent by weight of flat and elongated particles (5:1 ratio).

The entire HMA wearing course shall come from the same source of material and the same job mix formula, except when permission is obtained from the Department to change sources.

703.09 HMA Mixture Composition The coarse and fine aggregate shall meet the requirements of Section 703.07. The several aggregate fractions for mixtures shall be sized, graded, and combined in such proportions that the resulting composite blends, including RAP aggregate will meet the grading requirements of the following table:

Aggregate Gradation Control Points						
Nominal Maximum Aggregate Size---Control Points (Percent Passing)						
Sieve Designation	Type 25 mm	Type 19 mm	Type 12.5 mm	Type 9.5 mm	Type 9.5 mm Thin Lift Mixture (TLM)	Type 4.75 mm
Percent By Weight Passing - Combined Aggregate						
37.5 mm	100					
25 mm	90-100	100				
19 mm	-90	90-100	100			
12.5 mm	-	-90	90-100	100	100	100
9.5 mm	-	-	-90	90-100	95-100	95-100
4.75 mm	-	-	-	-90	60-95	80-100
2.36 mm	19-45	23-49	28-58	32-67	47-65	40 - 80
1.18 mm	-	-	-	-	-	-
0.60 mm	-	-	-	-	-	-
0.30 mm	-	-	-	-	-	-
0.075 mm	2.0-6.0	2.0-6.0	2.0-6.0	2.0-7.0*	2.0-7.0*	2.0-7.0

* For 9.5 mm nominal maximum aggregate size mixtures, the maximum design aim for the percent passing the 75 µm sieve is 6.5%.

SECTION 709 REINFORCING STEEL AND WELDED STEEL WIRE FABRIC

709.01 Reinforcing Steel Remove the second paragraph of Section 709.01 of the standard specification beginning with “Low-Carbon, Chromium,...” and replace with the following:

“ Low-carbon, chromium, reinforcing steel shall be deformed bars conforming to the requirements of ASTM A1035. Bars shall be Grade 100 and alloy Type CS unless otherwise specified on the Plans. “

SECTION 710 FENCE AND GUARDRAIL

710.06 Fence Posts and Braces Revise the first Paragraph so that it reads:

“Wood posts shall be of cedar, white oak, or tamarack or other AWPAs approved species, of the diameter or section and length shown on the plans.”

Remove the fourth paragraph which starts “ That portion of wood posts...”.

Revise the paragraph beginning with “Braces shall be of spruce, eastern hemlock ... so that it now reads:

“Braces shall be of spruce, eastern hemlock, Norway pine, pitch pine, or tamarack timbers or other AWPAs approved species, or spruce, cedar, tamarack or other AWPAs approved species round posts of sufficient length to make a diagonal brace between adjacent posts. All wood posts and braces shall be pressure-treated in accordance with AASHTO M 133 and AWPAs U1, UC4A Commodity Specification B: Posts. “

710.07 Guardrail Posts Revise this section so that the first sentence of section a. reads:

“a. Wood posts shall be of Norway pine, southern yellow pine, pitch pine, Douglas fir, red pine, white pine, or eastern hemlock or other AWPAs approved species.”

Revise the next paragraph so that it reads:

Wood posts and offset brackets shall be preservative treated in accordance with the requirements of AASHTO M 133 and AWPAs U1, UC4A Commodity Specification B: Posts.

710.08 Guardrail Hardware Revise this subsection by replacing “AASHTO M 298” with “ASTM B695”

SECTION 711 MISCELLANEOUS BRIDGE MATERIAL

711.06 Stud Shear Connector Anchors and Fasteners Amend this section by deleting it in its entirety and replacing it with:

“Shear connectors shall meet the dimensional tolerances of Figure 9.1 of the ANSI/AASHTO/AWS D1.5 Bridge Welding Code (D1.5 Code). Shear connectors, anchors and fasteners shall meet the material requirements of Section 9 of the D1.5 Code. Shear connectors shall meet the mechanical property requirements of Table 9.1, Type B of the D1.5 Code. Anchors and fasteners shall meet the mechanical property requirements of Table 9.1 of the D1.5 Code, Type A.”

SECTION 712
MISCELLANEOUS HIGHWAY MATERIAL

712.061 Structural Precast Units Amend this section by adding the following sentence to the end of the first paragraph of the Construction subsection:

“Facilities certified by NPCA or PCI shall provide to the Fabrication Engineer a copy of their annual audit to include deficiency reports and corrective actions.”

Revise this section by changing the letter “b” of ASTM C1611 of the Concrete Testing subsection so that it reads:

“b. Air content shall be 5.0% to 8.0%.”

SECTION 713
STRUCTURAL STEEL AND RELATED MATERIAL

Section 713.01 Structural Steel Replace paragraph two in its entirety with the following:

“Main load-carrying components subject to tensile stresses or stress reversal shall meet the notch toughness requirements in AASHTO M 270M, Table 11, Zone 2, for non-fracture critical steel or Table 12, Zone 2 for fracture critical steel. Frequency of tension tests shall comply with the requirements of S1.”

Section 713.02 High Strength Bolts Revise this subsection by removing the portion from the beginning up to and including TABLE 1 – Test Schedule*, and replace it with:

“Bolts shall conform to the requirements of ASTM F3125, Grade A325, Type 1 or Type 3. Type 3 bolts shall be supplied for all structures utilizing unpainted AASHTO M 270M weathering steel. Type 1 galvanized bolts shall be used for all structures utilizing metallized or galvanized steel.

Nuts shall meet the requirements of ASTM A563.

Circular and beveled washers shall conform to the requirements of ASTM F436.

Direct Tension Indicators (DTI’S) shall conform to the requirements of ASTM F959. DTI’s for use with painted steel shall have a plain “as fabricated” finish. DTI’s for use with unpainted steel shall be galvanized to the requirements of ASTM B695 Class 50, Type I and have a fusion-bonded epoxy coating. DTI’s used with galvanized steel, metallized steel and steel coated with a zinc-rich primer shall be galvanized to the requirements of ASTM B695 Class 50, Type I.

“Twist Off” Type Tension Control Structural Bolt/Nut/Washer Assemblies shall meet the requirements of ASTM F3125, Grade F1852.

Bolts, nuts and washers specified to be galvanized, shall be galvanized in accordance with AASHTO M 232 (ASTM A153), ASTM F2329, or ASTM B695 Class 50, Type I.

All fastener (bolts and nuts), whether black or galvanized, shall be coated with a suitable lubricant. Galvanized nuts shall be lubricated with a lubricant containing a visible dye.

Each lot of bolts, nuts, washers and DTI's shall be tested by the manufacturer in accordance with the tests tabulated in Table 1 - Test Schedule. The testing frequency for bolts, nuts and washers from each shipping lot of fasteners shall be as specified in the applicable AASHTO/ASTM Standard Specifications. The testing frequency for each production lot of DTI's shall be as specified in ASTM F959.

TABLE 1 - Test Schedule*

Bolts	Tensile Strength (Wedge Test)	ASTM F606
	Proof Load	ASTM F606
	Hardness	ASTM F606
	Coating Thickness	ASTM B695
Nuts	Proof Load	ASTM F606
	Hardness	ASTM F606
	Coating Thickness	ASTM B695
Washers	Hardness	ASTM F606
	Coating Thickness	ASTM B695
DTI's	Coating Thickness	ASTM B695
	Compression Load	ASTM F959

Section 716

STRUCTURAL ALUMINUM AND RELATED MATERIAL

716.01 Aluminum Railings: Revise this subsection by removing section d. and replacing with:

d. Steel Anchor Assembly Steel spacers for post anchors shall conform to the requirements of ASTM A36. Nuts embedded in concrete shall conform to the requirements of ASTM A307.

Anchor bolts, exposed nuts and washers shall conform to the requirements of ASTM A449 or ASTM F1554, Grade 55 and shall be galvanized in accordance with AASHTO M 232 (ASTM A153), ASTM F2329, or ASTM B695, Class 50, Type I.

SECTION 718

TRAFFIC SIGNALS MATERIAL

718.03 Signal Mounting Amend the paragraph beginning with “All trunions, brackets and...” by adding “**For polycarbonate signal heads with more than 3 sections or requiring mounting extensions greater than 12 inches in length, reinforcing plates shall be used to reinforce the housings at the point of attachment.**” to the end of the paragraph.

718.08 Controllor Cabinet Revise this subsection by replacing the paragraph beginning with “The cabinet shall be supplied with LED light panels...” on or about page 7-66 with **“The cabinet shall be supplied with white LED light panels which shall automatically illuminate via a door open switch whenever one of the four main cabinet doors are opened for the ground mount cabinet or two main doors for the side of pole cabinet. The ground mounted cabinet shall contain four LED light panels per side totaling eight panels for the cabinet; one panel each at the top and bottom portion of the front side and back side on the Control side and Power/Auxiliary side of the cabinet. Each light panel shall produce a minimum of 250 lumens for a total minimum lumen output of 2000 lumens with all eight panels illuminated. The minimum output per side would be 1000 lumens. The LED panels shall be protected by a clear shatterproof shield. The side of pole mounted cabinet shall contain four light panels; one at the top of the rack assembly and one at the bottom rack assembly on each side of the cabinet.**

A second door open status switch per door shall activate a controller input to log a report event that one of the doors was opened. All door open status switches shall be connected to the same controller input. For the ground mount cabinet, there shall be two switches on each of the four main doors. For the side-of-pole mount cabinet, there shall be two switches on each of the two main doors.”

Revise this subsection by replacing the paragraph beginning with “The cabinet shall be supplied with a generator panel ...” on or about page 7-68 with:

“The cabinet shall be supplied with a generator panel. The generator panel shall consist of a manual transfer switch and a twist-lock connector for generator hookup. The transfer switch knob and twist-lock connector shall be located inside a stainless steel enclosure with a separate lockable door accessed with a Corbin #2 key. The unit shall be mounted on the left, exterior of the control side wall of the ground mount cabinet a minimum of 36” above the surrounding grade and on the lower left side of the pole mounted cabinet. The generator transfer switch shall be a Reliance C30A1N Signa Series or approved equal. “

Revise this subsection by removing the following from the paragraph beginning with “The ground mounted cabinet shall be supplied and installed with an electric service meter socket trim and electrical service disconnect switch ...” on or about page 7-69: **“(removed: thus preventing that space from being used either by equipment supplied as part of the project, or future equipment that would be installed in the rack system. Joe indicated that he would add this language to the detail so it is covered.)”**.

Revise this subsection by replacing the following in the paragraph beginning with “The Contractor shall reconfigure the default user name...” on or around page 7-70; “MaineDOT IT” with **“MaineDOT Traffic Division”**.

In the paragraph beginning with “Tests shall be conducted by the contractor...” on or around page 7-73, amend this subsection by removing **“in the state of Maine and”** after “The facility shall be”.

Amend this Section by adding the following subsection:

718.13 Field Monitoring Unit (FMU) This item of work shall conform to this specification. This item shall consist of furnishing and installing a Field Monitoring Unit (FMU) and software, as well as all needed accessories required for a full and complete installation, including but not limited to power adapters, Ethernet cables, and interface cables, as described herein.

Where applicable, communications from MaineDOT's cloud-based Central Management System (CMS) to the on-street traffic signal controllers shall be made through fiber optic interconnect cable connected back to existing internet connections and/or the Field Monitoring Unit (FMU). The Contractor shall furnish and install all materials necessary for a complete and operational fiber optic interconnection to all project intersections as shown on the plans. All connections to the CMS cloud-based system shall be via a secure VPN network.

The FMU shall be the only remote connection device used by isolated intersections to connect to the cloud-based system. All connections shall be encrypted VPN tunnels. The Contractor shall coordinate all configuration settings with MaineDOT IT and the Engineer.

The FMU central web based interface shall be a separate element from the CMS.

MATERIALS: The materials for this work shall conform to the following requirements:

1. The work under this item specifies the requirements for the FMU. The FMU shall operate independent of the brand/type of intersection controller deployed in the ATC traffic cabinet.
2. The FMU shall conform to the following requirements:
 - 2.1 The FMU shall function correctly between -34 degrees C and +74 degrees C.
 - 2.2 The FMU shall be provided with appropriately rated connectors that allows the FMU to be exchanged by unplugging connectors, without tools.
 - 2.3 The FMU shall monitor and log all ATC Controller and ATC cabinet faults and or alarms.
 - 2.4 The FMU shall be wired directly to the ATC cabinet.
 - 2.5 The FMU shall have an internal cellular modem running at 4G LTE.
 - 2.5.1 The Cellular modem shall be designed to be replaced / upgraded to 5G service when available.
 - 2.6 The FMU shall incorporate an integrated GPS and cell modem.
 - 2.7 The configuration of the FMU shall be accomplished by accessing the internal web server with a browser. It shall be possible to configure the FMU without any special software.
 - 2.8 The FMU shall be powered via a standard 120V input power.

- 2.9 The FMU shall allow for the routing of the controller configuration packets to and from the controller (either by Ethernet or serial communications) for any type of controller utilized by the MaineDOT. In this way it shall be possible to configure the controller and utilize the controller specific software to interrogate the controller, and the FMU shall provide the communications pipe which allows this to be accomplished.
- 2.10 The FMU shall, within the size limitations above, include a battery and battery charging/monitoring circuit, to allow the FMU to function correctly even when all power to the intersection has failed. The battery shall continue to power the FMU for a minimum of 5 hours after all power has failed to the intersection.
- 2.11 The FMU shall incorporate an integrated GPS which will allow the FMU to geo-locate itself on the FMU management software map, without configuration.
- 2.12 The FMU shall operate without requiring a static IP address. The only configuration required at the FMU is to enter the URL of where the FMU management software is hosted.
- 2.13 In the event that the cell service is interrupted or is not available, the FMU shall store any events that occur in internal memory and forward these events automatically to the FMU management software when the cell service is restored. In this way, a complete record of events at the device can be maintained even if cell service is interrupted for a period. The system will store 5000 events.
- 2.14 The FMU shall utilize HTTP and HTTPS protocols, and XML data structures, for communication with the FMU management software. In this way the data will be open for future expansion and competition. The use of secret proprietary protocols is not permitted.
- 2.15 The FMU shall include Ethernet communications via an Ethernet Port with RJ45 connector.
- 2.16 The FMU shall include weather proof antennas.

3. Map Display FMU Management Software

- 3.1 The FMU shall include a scrollable, zoomable map display, with the intersections and other monitored devices shown as representative icons on the map. The map shall include the ability to see the intersections using Google Streetview.
- 3.2 The alarm status of the intersection shall be clearly indicated on the icon on the map, so that the user can see at a glance which intersections are in alarm.
- 3.3 The map display shall also include a list of intersections, with the number and priority of alarms indicated on the list. Intersections in high priority alarm shall be moved to the top

of the list, followed by medium priority, low priority and then finally by intersections not in alarm.

- 3.4 The icons shall change to be able to clearly indicate if an intersection is offline.
- 3.5 Clicking on the icon on the map shall expose a box with the current parameters of the intersection shown.
- 3.6 The default map display position and zoom shall be configurable by user, so that the user's view will default to show the intersections that the user is responsible for managing.
- 3.7 The map view shall have the ability to show Google traffic overlays on the map.

4. Intersection Detail Display FMU Management Software

- 4.1 It shall be possible to drill down, either from the map icon or from the list, to a device level detail for the intersection, which as a minimum shall display the following parameters:
 - 4.1.1 The alarm status, with priority indicated, and a text description of the alarm (if an alarm is present for this device).
 - 4.1.2 The time since the last communication with the device
 - 4.1.3 The following parameters (real time now values, minimum for the day values, maximum for the day values, and average for the day values)
 - 4.1.3.1 The AC mains voltage (value)
 - 4.1.3.2 The battery back-up voltage (value)
 - 4.1.3.3 The cabinet temperature (value)
 - 4.1.3.4 The cabinet humidity (value)
 - 4.1.3.5 The presence of AC power (OK or Fail)
 - 4.1.3.6 The flashing status of the intersection (OK or Flashing)
 - 4.1.3.7 Stop Time status (OK or Stop Time Active)
 - 4.1.3.8 The cabinet door status (Open or Closed)
 - 4.1.3.9 The intersection fan status (Fan On or Fan off)

4.1.4 It shall be possible to view graphs of each of the value parameters in graphical form, over the recent two-week period. This includes real time graphs of:

4.1.4.1 The AC mains voltage

4.1.4.2 The battery back-up voltage

4.1.4.3 The cabinet temperature

4.1.4.4 The cabinet humidity

5. Diagnostics and Log Display FMU Management Software

5.1 From the device level detail within the FMU management software, it shall be possible to drill down to get the raw data; the error logs; and the communications logs to allow a technician to fault-find problems.

5.2 It shall be possible to filter the logs by Device; by Device Type and/or by Group as well as between dates.

5.3 It shall be possible to print these selected logs to a local printer or a PDF file.

5.4 It shall be possible to export these logs to Excel on the local computer for further analysis.

6. Alarms FMU Management Software

6.1 The FMU management software shall have a comprehensive alarm generation capability

6.2 It shall be possible to configure alarms to be generated on any parameter becoming out of tolerance, including analog values, digital values and enumerated values.

6.3 Alarms shall be configurable to be of Low, High or Critical Priority.

6.4 The alarm priority shall be displayed throughout the FMU management software, on all displays, using color codes such as red-critical; yellow – high; and amber-low to indicate the priority of the alarm.

6.5 The current active alarms shall be accessible for view via an expandable window, to see which alarms are active and when the alarm occurred. The highest priority alarms shall rise to the top of the list.

7. Alerts FMU Management Software

7.1 The FMU management software shall have comprehensive alerting capability, to enable the response personnel to be notified when an abnormal situation has occurred.

- 7.2 It shall be possible to configure alerts to one or more personnel for each alarm. This will cause, as selected, an SMS and/or an email to be sent to the person when an alarm occurs.
- 7.3 The alert shall be configurable to optionally send via email and/or via SMS a message when an alarm clears.
- 7.4 The intention is that the FMU management software provides the alerts to the user in near real time. The SMS and email shall be issued within 30 seconds of the occurrence of event which results in an alert being issued.

8. **Hosting and Connectivity and Service FMU / FMU Management Software**

- 8.1 The contractor shall supply the FMU with the FMU manufacturers 10 year options for Connectivity and Service, as part of the purchase price. The Connectivity and Service agreement shall include at a minimum:
- 8.1.1 Cellular Connectivity
 - 8.1.2 No cellular overage charges
 - 8.1.3 Extended warranty on the hardware for the period of the Connectivity and Service Agreement
 - 8.1.4 Over-the-air software updates
 - 8.1.5 Over-the-air security updates
 - 8.1.6 Future Connected Vehicles Service

Section 719 SIGNING MATERIAL

719.072 Overhead Signing: Revise this subsection by replacing it in entirety with:

“Sign panels mounted to independent sign support structures and support structure components mounted to bridges passing over the highway are considered to be overhead signing. Overhead signing shall be mounted on W6 by 9 steel beams conforming to the requirements of ASTM A992/A992M, galvanized in accordance with AASHTO M 111 (ASTM A123), or the same size aluminum beams conforming to ASTM B221M, alloys and tempers of 6061-T6, 6063-T6 or 6005-T5. These components shall be horizontally spaced a maximum of 5¼ feet on center, extending from the bottom of sign panel to the top. If supplemental signs are included in the contract, these beams will extend from the bottom of the main sign panel to the top of the supplemental sign panel. The maximum distance from the edge of the sign to the center of the W6 by 9 shall not exceed approximately 3¼ feet.

On independent sign support structures, these W6 by 9 beam components shall be fastened to chords with a pair of appropriately sized U-bolts on each side of the web at each fastening

location. A similar pair of U-bolt assemblies shall be used in attaching each chord of an overhead component to upright supports. U-bolts for steel support structures shall conform to ASTM A449, Type 1. U-bolt hardware, which includes nuts, flat washers, and helical lock washers, shall be galvanized in accordance with AASHTO M 232 (ASTM A153), ASTM F2329, or ASTM B695, Class 50, Type I. Washers shall conform to the requirements of ASTM F436. The U-bolt material for aluminum support structures, or a combination of steel and aluminum structural components, shall be stainless steel conforming to the requirements of ASTM F593, alloy group 1, with a minimum yield strength of 45 ksi. Steel support structures may also utilize stainless steel hardware assemblies as an alternative to galvanized steel. Nuts shall be of the locking type with nylon inserts. Washers shall conform to the requirements of ASTM A276, Type 302. Flat washers, without helical lock washers, will be acceptable in this stainless steel assembly.

On bridge mounted structures, the fastener configurations shall be depicted in the contract documents. “

SECTION 720 STRUCTURAL SUPPORTS FOR HIGHWAY SIGNS, LUMINAIRES AND TRAFFIC SIGNALS

720.03 Steel Supports: Revise this subsection by removing the paragraph beginning with “Chord flange splice fastener” and replacing with:

“Chord flange splice fastener assemblies shall conform to ASTM A325, Type 1, and galvanized in accordance with AASHTO M 232 (ASTM A153), ASTM F2329, or ASTM B695, Class 50, Type I. Other fastener assemblies shall be as specified in Section 719.07, or as approved by the Fabrication Engineer.”

720.06 Steel H-beam: Revise this subsection by replacing it in its entirety with:

“Steel H-beam Post shall conform to the requirements of ASTM A992. All work shall conform to the applicable provisions of Section 504 – Structural Steel. Steel shall be hot-dip galvanized in accordance with AASHTO M 111 (ASTM A123). All steel hardware for use with H-beam poles shall be galvanized in accordance with AASHTO M 232 (ASTM A153), ASTM F2329, or ASTM B695, Class 50, Type I.”

720.07 Anchor Bolts: Revise this subsection by replacing it in its entirety with:

“Anchor bolts and nuts supplied for aluminum and/or steel supports shall conform to ASTM A449, Type 1, or ASTM F1554, Grade 55, both with a minimum yield strength of 55 ksi. Anchor bolts shall be supplied with 2 heavy hex nuts and 2 hardened washers and unless otherwise specified the anchor bolts shall have a 90° bend with a 6 inch minimum leg length at the lower end. The anchor bolts, nuts and hardened washers shall be galvanized in accordance with AASHTO M 232 (ASTM A153), ASTM F2329, or ASTM B695, Class 50, Type I. The bolt

shall be zinc-coated 12 inches from the exposed end, unless otherwise specified. If the anchor bolts are to be used with breakaway devices incorporating the function of a nut, for example, longitudinally grooved breakaway couplings, nuts or washers will not be required.

Alternate materials, grades, and designs may be used for anchor bolts subject to approval of the Fabrication Engineer.”

720.09 Wood Ornamental Light Standard: Revise this subsection by removing the paragraph beginning with “All bolts shall be” and replacing it with:

“All bolts shall be galvanized in accordance with AASHTO M 232 (ASTM A153), ASTM F2329, or ASTM B695, Class 50, Type I.”

720.12 Wood Sign Posts Revise the first sentence so that it reads:

“Wood sign posts shall be rectangular, straight and sound timber, cut from live growing native spruce, red pine, hemlock, cedar trees or other AWWA approved species, free from loose knots or other structurally weakening defects of importance, such as shake or holes or heart rot.”

Revise the third paragraph that starts with “When pressure treated...” so that it reads:

“All sign posts shall be pressure-treated in accordance with AASHTO M 133 and AWWA Standard U1, UC4A, Commodity Specification A: Sawn Products.”

**REQUIRED CONTRACT PROVISIONS
FEDERAL-AID CONSTRUCTION CONTRACTS**

- I. General
- II. Nondiscrimination
- III. Non-segregated Facilities
- IV. Davis-Bacon and Related Act Provisions
- V. Contract Work Hours and Safety Standards Act Provisions
- VI. Subletting or Assigning the Contract
- VII. Safety: Accident Prevention
- VIII. False Statements Concerning Highway Projects
- IX. Implementation of Clean Air Act and Federal Water Pollution Control Act
- X. Certification Regarding Debarment, Suspension, Ineligibility and Voluntary Exclusion
- XI. Certification Regarding Use of Contract Funds for Lobbying
- XII. Use of United States-Flag Vessels:

ATTACHMENTS

A. Employment and Materials Preference for Appalachian Development Highway System or Appalachian Local Access Road Contracts (included in Appalachian contracts only)

I. GENERAL

1. Form FHWA-1273 must be physically incorporated in each construction contract funded under title 23, United States Code, as required in 23 CFR 633.102(b) (excluding emergency contracts solely intended for debris removal). The contractor (or subcontractor) must insert this form in each subcontract and further require its inclusion in all lower tier subcontracts (excluding purchase orders, rental agreements and other agreements for supplies or services). 23 CFR 633.102(e).

The applicable requirements of Form FHWA-1273 are incorporated by reference for work done under any purchase order, rental agreement or agreement for other services. The prime contractor shall be responsible for compliance by any subcontractor, lower-tier subcontractor or service provider. 23 CFR 633.102(e).

Form FHWA-1273 must be included in all Federal-aid design-build contracts, in all subcontracts and in lower tier subcontracts (excluding subcontracts for design services, purchase orders, rental agreements and other agreements for supplies or services) in accordance with 23 CFR 633.102. The design-builder shall be responsible for compliance by any subcontractor, lower-tier subcontractor or service provider.

Contracting agencies may reference Form FHWA-1273 in solicitation-for-bids or request-for-proposals documents, however, the Form FHWA-1273 must be physically incorporated (not referenced) in all contracts, subcontracts and lower-tier subcontracts (excluding purchase orders, rental agreements and other agreements for supplies or services related to a construction contract). 23 CFR 633.102(b).

2. Subject to the applicability criteria noted in the following sections, these contract provisions shall apply to all work

performed on the contract by the contractor's own organization and with the assistance of workers under the contractor's immediate superintendence and to all work performed on the contract by piecework, station work, or by subcontract. 23 CFR 633.102(d).

3. A breach of any of the stipulations contained in these Required Contract Provisions may be sufficient grounds for withholding of progress payments, withholding of final payment, termination of the contract, suspension / debarment or any other action determined to be appropriate by the contracting agency and FHWA.

4. Selection of Labor: During the performance of this contract, the contractor shall not use convict labor for any purpose within the limits of a construction project on a Federal-aid highway unless it is labor performed by convicts who are on parole, supervised release, or probation. 23 U.S.C. 114(b). The term Federal-aid highway does not include roadways functionally classified as local roads or rural minor collectors. 23 U.S.C. 101(a).

II. NONDISCRIMINATION (23 CFR 230.107(a); 23 CFR Part 230, Subpart A, Appendix A; EO 11246)

The provisions of this section related to 23 CFR Part 230, Subpart A, Appendix A are applicable to all Federal-aid construction contracts and to all related construction subcontracts of \$10,000 or more. The provisions of 23 CFR Part 230 are not applicable to material supply, engineering, or architectural service contracts.

In addition, the contractor and all subcontractors must comply with the following policies: Executive Order 11246, 41 CFR Part 60, 29 CFR Parts 1625-1627, 23 U.S.C. 140, Section 504 of the Rehabilitation Act of 1973, as amended (29 U.S.C. 794), Title VI of the Civil Rights Act of 1964, as amended (42 U.S.C. 2000d et seq.), and related regulations including 49 CFR Parts 21, 26, and 27; and 23 CFR Parts 200, 230, and 633.

The contractor and all subcontractors must comply with: the requirements of the Equal Opportunity Clause in 41 CFR 60-1.4(b) and, for all construction contracts exceeding \$10,000, the Standard Federal Equal Employment Opportunity Construction Contract Specifications in 41 CFR 60-4.3.

Note: The U.S. Department of Labor has exclusive authority to determine compliance with Executive Order 11246 and the policies of the Secretary of Labor including 41 CFR Part 60, and 29 CFR Parts 1625-1627. The contracting agency and the FHWA have the authority and the responsibility to ensure compliance with 23 U.S.C. 140, Section 504 of the Rehabilitation Act of 1973, as amended (29 U.S.C. 794), and Title VI of the Civil Rights Act of 1964, as amended (42 U.S.C. 2000d et seq.), and related regulations including 49 CFR Parts 21, 26, and 27; and 23 CFR Parts 200, 230, and 633.

The following provision is adopted from 23 CFR Part 230, Subpart A, Appendix A, with appropriate revisions to conform to the U.S. Department of Labor (US DOL) and FHWA requirements.

1. Equal Employment Opportunity: Equal Employment Opportunity (EEO) requirements not to discriminate and to take affirmative action to assure equal opportunity as set forth under laws, executive orders, rules, regulations (see 28 CFR Part 35, 29 CFR Part 1630, 29 CFR Parts 1625-1627, 41 CFR Part 60 and 49 CFR Part 27) and orders of the Secretary of Labor as modified by the provisions prescribed herein, and imposed pursuant to 23 U.S.C. 140, shall constitute the EEO and specific affirmative action standards for the contractor's project activities under this contract. The provisions of the Americans with Disabilities Act of 1990 (42 U.S.C. 12101 et seq.) set forth under 28 CFR Part 35 and 29 CFR Part 1630 are incorporated by reference in this contract. In the execution of this contract, the contractor agrees to comply with the following minimum specific requirement activities of EEO:

a. The contractor will work with the contracting agency and the Federal Government to ensure that it has made every good faith effort to provide equal opportunity with respect to all of its terms and conditions of employment and in their review of activities under the contract. 23 CFR 230.409 (g)(4) & (5).

b. The contractor will accept as its operating policy the following statement:

"It is the policy of this Company to assure that applicants are employed, and that employees are treated during employment, without regard to their race, religion, sex, sexual orientation, gender identity, color, national origin, age or disability. Such action shall include: employment, upgrading, demotion, or transfer; recruitment or recruitment advertising; layoff or termination; rates of pay or other forms of compensation; and selection for training, including apprenticeship, pre-apprenticeship, and/or on-the-job training."

2. EEO Officer: The contractor will designate and make known to the contracting officers an EEO Officer who will have the responsibility for and must be capable of effectively administering and promoting an active EEO program and who must be assigned adequate authority and responsibility to do so.

3. Dissemination of Policy: All members of the contractor's staff who are authorized to hire, supervise, promote, and discharge employees, or who recommend such action or are substantially involved in such action, will be made fully cognizant of and will implement the contractor's EEO policy and contractual responsibilities to provide EEO in each grade and classification of employment. To ensure that the above agreement will be met, the following actions will be taken as a minimum:

a. Periodic meetings of supervisory and personnel office employees will be conducted before the start of work and then not less often than once every six months, at which time the contractor's EEO policy and its implementation will be reviewed and explained. The meetings will be conducted by the EEO Officer or other knowledgeable company official.

b. All new supervisory or personnel office employees will be given a thorough indoctrination by the EEO Officer, covering all major aspects of the contractor's EEO obligations within thirty days following their reporting for duty with the contractor.

c. All personnel who are engaged in direct recruitment for the project will be instructed by the EEO Officer in the contractor's procedures for locating and hiring minorities and women.

d. Notices and posters setting forth the contractor's EEO policy will be placed in areas readily accessible to employees, applicants for employment and potential employees.

e. The contractor's EEO policy and the procedures to implement such policy will be brought to the attention of employees by means of meetings, employee handbooks, or other appropriate means.

4. Recruitment: When advertising for employees, the contractor will include in all advertisements for employees the notation: "An Equal Opportunity Employer." All such advertisements will be placed in publications having a large circulation among minorities and women in the area from which the project work force would normally be derived.

a. The contractor will, unless precluded by a valid bargaining agreement, conduct systematic and direct recruitment through public and private employee referral sources likely to yield qualified minorities and women. To meet this requirement, the contractor will identify sources of potential minority group employees and establish with such identified sources procedures whereby minority and women applicants may be referred to the contractor for employment consideration.

b. In the event the contractor has a valid bargaining agreement providing for exclusive hiring hall referrals, the contractor is expected to observe the provisions of that agreement to the extent that the system meets the contractor's compliance with EEO contract provisions. Where implementation of such an agreement has the effect of discriminating against minorities or women, or obligates the contractor to do the same, such implementation violates Federal nondiscrimination provisions.

c. The contractor will encourage its present employees to refer minorities and women as applicants for employment. Information and procedures with regard to referring such applicants will be discussed with employees.

5. Personnel Actions: Wages, working conditions, and employee benefits shall be established and administered, and personnel actions of every type, including hiring, upgrading, promotion, transfer, demotion, layoff, and termination, shall be taken without regard to race, color, religion, sex, sexual orientation, gender identity, national origin, age or disability. The following procedures shall be followed:

a. The contractor will conduct periodic inspections of project sites to ensure that working conditions and employee facilities do not indicate discriminatory treatment of project site personnel.

b. The contractor will periodically evaluate the spread of wages paid within each classification to determine any evidence of discriminatory wage practices.

c. The contractor will periodically review selected personnel actions in depth to determine whether there is evidence of discrimination. Where evidence is found, the contractor will promptly take corrective action. If the review indicates that the discrimination may extend beyond the actions reviewed, such corrective action shall include all affected persons.

d. The contractor will promptly investigate all complaints of alleged discrimination made to the contractor in connection with its obligations under this contract, will attempt to resolve such complaints, and will take appropriate corrective action

within a reasonable time. If the investigation indicates that the discrimination may affect persons other than the complainant, such corrective action shall include such other persons. Upon completion of each investigation, the contractor will inform every complainant of all of their avenues of appeal.

6. Training and Promotion:

a. The contractor will assist in locating, qualifying, and increasing the skills of minorities and women who are applicants for employment or current employees. Such efforts should be aimed at developing full journey level status employees in the type of trade or job classification involved.

b. Consistent with the contractor's work force requirements and as permissible under Federal and State regulations, the contractor shall make full use of training programs (i.e., apprenticeship and on-the-job training programs for the geographical area of contract performance). In the event a special provision for training is provided under this contract, this subparagraph will be superseded as indicated in the special provision. The contracting agency may reserve training positions for persons who receive welfare assistance in accordance with 23 U.S.C. 140(a).

c. The contractor will advise employees and applicants for employment of available training programs and entrance requirements for each.

d. The contractor will periodically review the training and promotion potential of employees who are minorities and women and will encourage eligible employees to apply for such training and promotion.

7. Unions: If the contractor relies in whole or in part upon unions as a source of employees, the contractor will use good faith efforts to obtain the cooperation of such unions to increase opportunities for minorities and women. 23 CFR 230.409. Actions by the contractor, either directly or through a contractor's association acting as agent, will include the procedures set forth below:

a. The contractor will use good faith efforts to develop, in cooperation with the unions, joint training programs aimed toward qualifying more minorities and women for membership in the unions and increasing the skills of minorities and women so that they may qualify for higher paying employment.

b. The contractor will use good faith efforts to incorporate an EEO clause into each union agreement to the end that such union will be contractually bound to refer applicants without regard to their race, color, religion, sex, sexual orientation, gender identity, national origin, age, or disability.

c. The contractor is to obtain information as to the referral practices and policies of the labor union except that to the extent such information is within the exclusive possession of the labor union and such labor union refuses to furnish such information to the contractor, the contractor shall so certify to the contracting agency and shall set forth what efforts have been made to obtain such information.

d. In the event the union is unable to provide the contractor with a reasonable flow of referrals within the time limit set forth in the collective bargaining agreement, the contractor will, through independent recruitment efforts, fill the employment vacancies without regard to race, color, religion, sex, sexual orientation, gender identity, national origin, age, or disability; making full efforts to obtain qualified and/or qualifiable minorities and women. The failure of a union to provide

sufficient referrals (even though it is obligated to provide exclusive referrals under the terms of a collective bargaining agreement) does not relieve the contractor from the requirements of this paragraph. In the event the union referral practice prevents the contractor from meeting the obligations pursuant to Executive Order 11246, as amended, and these special provisions, such contractor shall immediately notify the contracting agency.

8. Reasonable Accommodation for Applicants / Employees with Disabilities: The contractor must be familiar with the requirements for and comply with the Americans with Disabilities Act and all rules and regulations established thereunder. Employers must provide reasonable accommodation in all employment activities unless to do so would cause an undue hardship.

9. Selection of Subcontractors, Procurement of Materials and Leasing of Equipment: The contractor shall not discriminate on the grounds of race, color, religion, sex, sexual orientation, gender identity, national origin, age, or disability in the selection and retention of subcontractors, including procurement of materials and leases of equipment. The contractor shall take all necessary and reasonable steps to ensure nondiscrimination in the administration of this contract.

a. The contractor shall notify all potential subcontractors, suppliers, and lessors of their EEO obligations under this contract.

b. The contractor will use good faith efforts to ensure subcontractor compliance with their EEO obligations.

10. Assurances Required:

a. The requirements of 49 CFR Part 26 and the State DOT's FHWA-approved Disadvantaged Business Enterprise (DBE) program are incorporated by reference.

b. The contractor, subrecipient or subcontractor shall not discriminate on the basis of race, color, national origin, or sex in the performance of this contract. The contractor shall carry out applicable requirements of 49 CFR part 26 in the award and administration of DOT-assisted contracts. Failure by the contractor to carry out these requirements is a material breach of this contract, which may result in the termination of this contract or such other remedy as the recipient deems appropriate, which may include, but is not limited to:

- (1) Withholding monthly progress payments;
- (2) Assessing sanctions;
- (3) Liquidated damages; and/or
- (4) Disqualifying the contractor from future bidding as non-responsible.

c. The Title VI and nondiscrimination provisions of U.S. DOT Order 1050.2A at Appendixes A and E are incorporated by reference. 49 CFR Part 21.

11. Records and Reports: The contractor shall keep such records as necessary to document compliance with the EEO requirements. Such records shall be retained for a period of three years following the date of the final payment to the contractor for all contract work and shall be available at reasonable times and places for inspection by authorized representatives of the contracting agency and the FHWA.

a. The records kept by the contractor shall document the following:

(1) The number and work hours of minority and non-minority group members and women employed in each work classification on the project;

(2) The progress and efforts being made in cooperation with unions, when applicable, to increase employment opportunities for minorities and women; and

(3) The progress and efforts being made in locating, hiring, training, qualifying, and upgrading minorities and women.

b. The contractors and subcontractors will submit an annual report to the contracting agency each July for the duration of the project indicating the number of minority, women, and non-minority group employees currently engaged in each work classification required by the contract work. This information is to be reported on [Form FHWA-1391](#). The staffing data should represent the project work force on board in all or any part of the last payroll period preceding the end of July. If on-the-job training is being required by special provision, the contractor will be required to collect and report training data. The employment data should reflect the work force on board during all or any part of the last payroll period preceding the end of July.

III. NONSEGREGATED FACILITIES

This provision is applicable to all Federal-aid construction contracts and to all related construction subcontracts of more than \$10,000. 41 CFR 60-1.5.

As prescribed by 41 CFR 60-1.8, the contractor must ensure that facilities provided for employees are provided in such a manner that segregation on the basis of race, color, religion, sex, sexual orientation, gender identity, or national origin cannot result. The contractor may neither require such segregated use by written or oral policies nor tolerate such use by employee custom. The contractor's obligation extends further to ensure that its employees are not assigned to perform their services at any location under the contractor's control where the facilities are segregated. The term "facilities" includes waiting rooms, work areas, restaurants and other eating areas, time clocks, restrooms, washrooms, locker rooms and other storage or dressing areas, parking lots, drinking fountains, recreation or entertainment areas, transportation, and housing provided for employees. The contractor shall provide separate or single-user restrooms and necessary dressing or sleeping areas to assure privacy between sexes.

IV. DAVIS-BACON AND RELATED ACT PROVISIONS

This section is applicable to all Federal-aid construction projects exceeding \$2,000 and to all related subcontracts and lower-tier subcontracts (regardless of subcontract size), in accordance with 29 CFR 5.5. The requirements apply to all projects located within the right-of-way of a roadway that is functionally classified as Federal-aid highway. 23 U.S.C. 113. This excludes roadways functionally classified as local roads or rural minor collectors, which are exempt. 23 U.S.C. 101. Where applicable law requires that projects be treated as a project on a Federal-aid highway, the provisions of this subpart will apply regardless of the location of the project. Examples include: Surface Transportation Block Grant Program projects funded under 23 U.S.C. 133 [excluding recreational trails projects], the Nationally Significant Freight and Highway

Projects funded under 23 U.S.C. 117, and National Highway Freight Program projects funded under 23 U.S.C. 167.

The following provisions are from the U.S. Department of Labor regulations in 29 CFR 5.5 "Contract provisions and related matters" with minor revisions to conform to the FHWA-1273 format and FHWA program requirements.

1. Minimum wages (29 CFR 5.5)

a. *Wage rates and fringe benefits.* All laborers and mechanics employed or working upon the site of the work (or otherwise working in construction or development of the project under a development statute), will be paid unconditionally and not less often than once a week, and without subsequent deduction or rebate on any account (except such payroll deductions as are permitted by regulations issued by the Secretary of Labor under the Copeland Act ([29 CFR part 3](#))), the full amount of basic hourly wages and bona fide fringe benefits (or cash equivalents thereof) due at time of payment computed at rates not less than those contained in the wage determination of the Secretary of Labor which is attached hereto and made a part hereof, regardless of any contractual relationship which may be alleged to exist between the contractor and such laborers and mechanics. As provided in paragraphs (d) and (e) of 29 CFR 5.5, the appropriate wage determinations are effective by operation of law even if they have not been attached to the contract. Contributions made or costs reasonably anticipated for bona fide fringe benefits under the Davis-Bacon Act ([40 U.S.C. 3141\(2\)\(B\)](#)) on behalf of laborers or mechanics are considered wages paid to such laborers or mechanics, subject to the provisions of paragraph 1.e. of this section; also, regular contributions made or costs incurred for more than a weekly period (but not less often than quarterly) under plans, funds, or programs which cover the particular weekly period, are deemed to be constructively made or incurred during such weekly period. Such laborers and mechanics must be paid the appropriate wage rate and fringe benefits on the wage determination for the classification(s) of work actually performed, without regard to skill, except as provided in paragraph 4. of this section. Laborers or mechanics performing work in more than one classification may be compensated at the rate specified for each classification for the time actually worked therein: *Provided*, That the employer's payroll records accurately set forth the time spent in each classification in which work is performed. The wage determination (including any additional classifications and wage rates conformed under paragraph 1.c. of this section) and the Davis-Bacon poster (WH-1321) must be posted at all times by the contractor and its subcontractors at the site of the work in a prominent and accessible place where it can be easily seen by the workers.

b. *Frequently recurring classifications.* (1) In addition to wage and fringe benefit rates that have been determined to be prevailing under the procedures set forth in [29 CFR part 1](#), a wage determination may contain, pursuant to § 1.3(f), wage and fringe benefit rates for classifications of laborers and mechanics for which conformance requests are regularly submitted pursuant to paragraph 1.c. of this section, provided that:

(i) The work performed by the classification is not performed by a classification in the wage determination for which a prevailing wage rate has been determined;

(ii) The classification is used in the area by the construction industry; and

(iii) The wage rate for the classification bears a reasonable relationship to the prevailing wage rates contained in the wage determination.

(2) The Administrator will establish wage rates for such classifications in accordance with paragraph 1.c.(1)(iii) of this section. Work performed in such a classification must be paid at no less than the wage and fringe benefit rate listed on the wage determination for such classification.

c. *Conformance.* (1) The contracting officer must require that any class of laborers or mechanics, including helpers, which is not listed in the wage determination and which is to be employed under the contract be classified in conformance with the wage determination. Conformance of an additional classification and wage rate and fringe benefits is appropriate only when the following criteria have been met:

(i) The work to be performed by the classification requested is not performed by a classification in the wage determination; and

(ii) The classification is used in the area by the construction industry; and

(iii) The proposed wage rate, including any bona fide fringe benefits, bears a reasonable relationship to the wage rates contained in the wage determination.

(2) The conformance process may not be used to split, subdivide, or otherwise avoid application of classifications listed in the wage determination.

(3) If the contractor and the laborers and mechanics to be employed in the classification (if known), or their representatives, and the contracting officer agree on the classification and wage rate (including the amount designated for fringe benefits where appropriate), a report of the action taken will be sent by the contracting officer by email to DBAconformance@dol.gov. The Administrator, or an authorized representative, will approve, modify, or disapprove every additional classification action within 30 days of receipt and so advise the contracting officer or will notify the contracting officer within the 30-day period that additional time is necessary.

(4) In the event the contractor, the laborers or mechanics to be employed in the classification or their representatives, and the contracting officer do not agree on the proposed classification and wage rate (including the amount designated for fringe benefits, where appropriate), the contracting officer will, by email to DBAconformance@dol.gov, refer the questions, including the views of all interested parties and the recommendation of the contracting officer, to the Administrator for determination. The Administrator, or an authorized representative, will issue a determination within 30 days of receipt and so advise the contracting officer or will notify the contracting officer within the 30-day period that additional time is necessary.

(5) The contracting officer must promptly notify the contractor of the action taken by the Wage and Hour Division

under paragraphs 1.c.(3) and (4) of this section. The contractor must furnish a written copy of such determination to each affected worker or it must be posted as a part of the wage determination. The wage rate (including fringe benefits where appropriate) determined pursuant to paragraph 1.c.(3) or (4) of this section must be paid to all workers performing work in the classification under this contract from the first day on which work is performed in the classification.

d. *Fringe benefits not expressed as an hourly rate.* Whenever the minimum wage rate prescribed in the contract for a class of laborers or mechanics includes a fringe benefit which is not expressed as an hourly rate, the contractor may either pay the benefit as stated in the wage determination or may pay another bona fide fringe benefit or an hourly cash equivalent thereof.

e. *Unfunded plans.* If the contractor does not make payments to a trustee or other third person, the contractor may consider as part of the wages of any laborer or mechanic the amount of any costs reasonably anticipated in providing bona fide fringe benefits under a plan or program, *Provided*, That the Secretary of Labor has found, upon the written request of the contractor, in accordance with the criteria set forth in § 5.28, that the applicable standards of the Davis-Bacon Act have been met. The Secretary of Labor may require the contractor to set aside in a separate account assets for the meeting of obligations under the plan or program.

f. *Interest.* In the event of a failure to pay all or part of the wages required by the contract, the contractor will be required to pay interest on any underpayment of wages.

2. Withholding (29 CFR 5.5)

a. *Withholding requirements.* The contracting agency may, upon its own action, or must, upon written request of an authorized representative of the Department of Labor, withhold or cause to be withheld from the contractor so much of the accrued payments or advances as may be considered necessary to satisfy the liabilities of the prime contractor or any subcontractor for the full amount of wages and monetary relief, including interest, required by the clauses set forth in this section for violations of this contract, or to satisfy any such liabilities required by any other Federal contract, or federally assisted contract subject to Davis-Bacon labor standards, that is held by the same prime contractor (as defined in § 5.2). The necessary funds may be withheld from the contractor under this contract, any other Federal contract with the same prime contractor, or any other federally assisted contract that is subject to Davis-Bacon labor standards requirements and is held by the same prime contractor, regardless of whether the other contract was awarded or assisted by the same agency, and such funds may be used to satisfy the contractor liability for which the funds were withheld. In the event of a contractor's failure to pay any laborer or mechanic, including any apprentice or helper working on the site of the work all or part of the wages required by the contract, or upon the contractor's failure to submit the required records as discussed in paragraph 3.d. of this section, the contracting agency may on its own initiative and after written notice to the contractor, take such action as may be necessary to cause the suspension of any further payment, advance, or guarantee of funds until such violations have ceased.

b. *Priority to withheld funds.* The Department has priority to funds withheld or to be withheld in accordance with paragraph

2.a. of this section or Section V, paragraph 3.a., or both, over claims to those funds by:

- (1) A contractor's surety(ies), including without limitation performance bond sureties and payment bond sureties;
- (2) A contracting agency for its procurement costs;
- (3) A trustee(s) (either a court-appointed trustee or a U.S. trustee, or both) in bankruptcy of a contractor, or a contractor's bankruptcy estate;
- (4) A contractor's assignee(s);
- (5) A contractor's successor(s); or
- (6) A claim asserted under the Prompt Payment Act, [31 U.S.C. 3901–3907](#).

3. Records and certified payrolls (29 CFR 5.5)

a. *Basic record requirements (1) Length of record retention.* All regular payrolls and other basic records must be maintained by the contractor and any subcontractor during the course of the work and preserved for all laborers and mechanics working at the site of the work (or otherwise working in construction or development of the project under a development statute) for a period of at least 3 years after all the work on the prime contract is completed.

(2) *Information required.* Such records must contain the name; Social Security number; last known address, telephone number, and email address of each such worker; each worker's correct classification(s) of work actually performed; hourly rates of wages paid (including rates of contributions or costs anticipated for bona fide fringe benefits or cash equivalents thereof of the types described in [40 U.S.C. 3141\(2\)\(B\)](#) of the Davis-Bacon Act); daily and weekly number of hours actually worked in total and on each covered contract; deductions made; and actual wages paid.

(3) *Additional records relating to fringe benefits.* Whenever the Secretary of Labor has found under paragraph 1.e. of this section that the wages of any laborer or mechanic include the amount of any costs reasonably anticipated in providing benefits under a plan or program described in [40 U.S.C. 3141\(2\)\(B\)](#) of the Davis-Bacon Act, the contractor must maintain records which show that the commitment to provide such benefits is enforceable, that the plan or program is financially responsible, and that the plan or program has been communicated in writing to the laborers or mechanics affected, and records which show the costs anticipated or the actual cost incurred in providing such benefits.

(4) *Additional records relating to apprenticeship.* Contractors with apprentices working under approved programs must maintain written evidence of the registration of apprenticeship programs, the registration of the apprentices, and the ratios and wage rates prescribed in the applicable programs.

b. *Certified payroll requirements (1) Frequency and method of submission.* The contractor or subcontractor must submit weekly, for each week in which any DBA- or Related Acts-covered work is performed, certified payrolls to the contracting

agency. The prime contractor is responsible for the submission of all certified payrolls by all subcontractors. A contracting agency or prime contractor may permit or require contractors to submit certified payrolls through an electronic system, as long as the electronic system requires a legally valid electronic signature; the system allows the contractor, the contracting agency, and the Department of Labor to access the certified payrolls upon request for at least 3 years after the work on the prime contract has been completed; and the contracting agency or prime contractor permits other methods of submission in situations where the contractor is unable or limited in its ability to use or access the electronic system.

(2) *Information required.* The certified payrolls submitted must set out accurately and completely all of the information required to be maintained under paragraph 3.a.(2) of this section, except that full Social Security numbers and last known addresses, telephone numbers, and email addresses must not be included on weekly transmittals. Instead, the certified payrolls need only include an individually identifying number for each worker (e.g., the last four digits of the worker's Social Security number). The required weekly certified payroll information may be submitted using Optional Form WH-347 or in any other format desired. Optional Form WH-347 is available for this purpose from the Wage and Hour Division website at <https://www.dol.gov/sites/dolgov/files/WHD/legacy/files/wh347.pdf> or its successor website. It is not a violation of this section for a prime contractor to require a subcontractor to provide full Social Security numbers and last known addresses, telephone numbers, and email addresses to the prime contractor for its own records, without weekly submission by the subcontractor to the contracting agency.

(3) *Statement of Compliance.* Each certified payroll submitted must be accompanied by a "Statement of Compliance," signed by the contractor or subcontractor, or the contractor's or subcontractor's agent who pays or supervises the payment of the persons working on the contract, and must certify the following:

(i) That the certified payroll for the payroll period contains the information required to be provided under paragraph 3.b. of this section, the appropriate information and basic records are being maintained under paragraph 3.a. of this section, and such information and records are correct and complete;

(ii) That each laborer or mechanic (including each helper and apprentice) working on the contract during the payroll period has been paid the full weekly wages earned, without rebate, either directly or indirectly, and that no deductions have been made either directly or indirectly from the full wages earned, other than permissible deductions as set forth in [29 CFR part 3](#); and

(iii) That each laborer or mechanic has been paid not less than the applicable wage rates and fringe benefits or cash equivalents for the classification(s) of work actually performed, as specified in the applicable wage determination incorporated into the contract.

(4) *Use of Optional Form WH-347.* The weekly submission of a properly executed certification set forth on the reverse side of Optional Form WH-347 will satisfy the requirement for submission of the "Statement of Compliance" required by paragraph 3.b.(3) of this section.

(5) *Signature*. The signature by the contractor, subcontractor, or the contractor's or subcontractor's agent must be an original handwritten signature or a legally valid electronic signature.

(6) *Falsification*. The falsification of any of the above certifications may subject the contractor or subcontractor to civil or criminal prosecution under [18 U.S.C. 1001](#) and [31 U.S.C. 3729](#).

(7) *Length of certified payroll retention*. The contractor or subcontractor must preserve all certified payrolls during the course of the work and for a period of 3 years after all the work on the prime contract is completed.

c. *Contracts, subcontracts, and related documents*. The contractor or subcontractor must maintain this contract or subcontract and related documents including, without limitation, bids, proposals, amendments, modifications, and extensions. The contractor or subcontractor must preserve these contracts, subcontracts, and related documents during the course of the work and for a period of 3 years after all the work on the prime contract is completed.

d. *Required disclosures and access* (1) *Required record disclosures and access to workers*. The contractor or subcontractor must make the records required under paragraphs 3.a. through 3.c. of this section, and any other documents that the contracting agency, the State DOT, the FHWA, or the Department of Labor deems necessary to determine compliance with the labor standards provisions of any of the applicable statutes referenced by § 5.1, available for inspection, copying, or transcription by authorized representatives of the contracting agency, the State DOT, the FHWA, or the Department of Labor, and must permit such representatives to interview workers during working hours on the job.

(2) *Sanctions for non-compliance with records and worker access requirements*. If the contractor or subcontractor fails to submit the required records or to make them available, or refuses to permit worker interviews during working hours on the job, the Federal agency may, after written notice to the contractor, sponsor, applicant, owner, or other entity, as the case may be, that maintains such records or that employs such workers, take such action as may be necessary to cause the suspension of any further payment, advance, or guarantee of funds. Furthermore, failure to submit the required records upon request or to make such records available, or to permit worker interviews during working hours on the job, may be grounds for debarment action pursuant to § 5.12. In addition, any contractor or other person that fails to submit the required records or make those records available to WHD within the time WHD requests that the records be produced will be precluded from introducing as evidence in an administrative proceeding under [29 CFR part 6](#) any of the required records that were not provided or made available to WHD. WHD will take into consideration a reasonable request from the contractor or person for an extension of the time for submission of records. WHD will determine the reasonableness of the request and may consider, among other things, the location of the records and the volume of production.

(3) *Required information disclosures*. Contractors and subcontractors must maintain the full Social Security number and last known address, telephone number, and email address

of each covered worker, and must provide them upon request to the contracting agency, the State DOT, the FHWA, the contractor, or the Wage and Hour Division of the Department of Labor for purposes of an investigation or other compliance action.

4. Apprentices and equal employment opportunity (29 CFR 5.5)

a. *Apprentices* (1) *Rate of pay*. Apprentices will be permitted to work at less than the predetermined rate for the work they perform when they are employed pursuant to and individually registered in a bona fide apprenticeship program registered with the U.S. Department of Labor, Employment and Training Administration, Office of Apprenticeship (OA), or with a State Apprenticeship Agency recognized by the OA. A person who is not individually registered in the program, but who has been certified by the OA or a State Apprenticeship Agency (where appropriate) to be eligible for probationary employment as an apprentice, will be permitted to work at less than the predetermined rate for the work they perform in the first 90 days of probationary employment as an apprentice in such a program. In the event the OA or a State Apprenticeship Agency recognized by the OA withdraws approval of an apprenticeship program, the contractor will no longer be permitted to use apprentices at less than the applicable predetermined rate for the work performed until an acceptable program is approved.

(2) *Fringe benefits*. Apprentices must be paid fringe benefits in accordance with the provisions of the apprenticeship program. If the apprenticeship program does not specify fringe benefits, apprentices must be paid the full amount of fringe benefits listed on the wage determination for the applicable classification. If the Administrator determines that a different practice prevails for the applicable apprentice classification, fringe benefits must be paid in accordance with that determination.

(3) *Apprenticeship ratio*. The allowable ratio of apprentices to journeyworkers on the job site in any craft classification must not be greater than the ratio permitted to the contractor as to the entire work force under the registered program or the ratio applicable to the locality of the project pursuant to paragraph 4.a.(4) of this section. Any worker listed on a payroll at an apprentice wage rate, who is not registered or otherwise employed as stated in paragraph 4.a.(1) of this section, must be paid not less than the applicable wage rate on the wage determination for the classification of work actually performed. In addition, any apprentice performing work on the job site in excess of the ratio permitted under this section must be paid not less than the applicable wage rate on the wage determination for the work actually performed.

(4) *Reciprocity of ratios and wage rates*. Where a contractor is performing construction on a project in a locality other than the locality in which its program is registered, the ratios and wage rates (expressed in percentages of the journeyworker's hourly rate) applicable within the locality in which the construction is being performed must be observed. If there is no applicable ratio or wage rate for the locality of the project, the ratio and wage rate specified in the contractor's registered program must be observed.

b. *Equal employment opportunity*. The use of apprentices and journeyworkers under this part must be in conformity with

the equal employment opportunity requirements of Executive Order 11246, as amended, and [29 CFR part 30](#).

c. Apprentices and Trainees (programs of the U.S. DOT).

Apprentices and trainees working under apprenticeship and skill training programs which have been certified by the Secretary of Transportation as promoting EEO in connection with Federal-aid highway construction programs are not subject to the requirements of paragraph 4 of this Section IV. 23 CFR 230.111(e)(2). The straight time hourly wage rates for apprentices and trainees under such programs will be established by the particular programs. The ratio of apprentices and trainees to journeyworkers shall not be greater than permitted by the terms of the particular program.

5. Compliance with Copeland Act requirements. The contractor shall comply with the requirements of 29 CFR part 3, which are incorporated by reference in this contract as provided in 29 CFR 5.5.

6. Subcontracts. The contractor or subcontractor must insert FHWA-1273 in any subcontracts, along with the applicable wage determination(s) and such other clauses or contract modifications as the contracting agency may by appropriate instructions require, and a clause requiring the subcontractors to include these clauses and wage determination(s) in any lower tier subcontracts. The prime contractor is responsible for the compliance by any subcontractor or lower tier subcontractor with all the contract clauses in this section. In the event of any violations of these clauses, the prime contractor and any subcontractor(s) responsible will be liable for any unpaid wages and monetary relief, including interest from the date of the underpayment or loss, due to any workers of lower-tier subcontractors, and may be subject to debarment, as appropriate. 29 CFR 5.5.

7. Contract termination: debarment. A breach of the contract clauses in 29 CFR 5.5 may be grounds for termination of the contract, and for debarment as a contractor and a subcontractor as provided in 29 CFR 5.12.

8. Compliance with Davis-Bacon and Related Act requirements. All rulings and interpretations of the Davis-Bacon and Related Acts contained in 29 CFR parts 1, 3, and 5 are herein incorporated by reference in this contract as provided in 29 CFR 5.5.

9. Disputes concerning labor standards. As provided in 29 CFR 5.5, disputes arising out of the labor standards provisions of this contract shall not be subject to the general disputes clause of this contract. Such disputes shall be resolved in accordance with the procedures of the Department of Labor set forth in 29 CFR parts 5, 6, and 7. Disputes within the meaning of this clause include disputes between the contractor (or any of its subcontractors) and the contracting agency, the U.S. Department of Labor, or the employees or their representatives.

10. Certification of eligibility. a. By entering into this contract, the contractor certifies that neither it nor any person or firm who has an interest in the contractor's firm is a person or firm ineligible to be awarded Government contracts by virtue of [40 U.S.C. 3144\(b\)](#) or § 5.12(a).

b. No part of this contract shall be subcontracted to any person or firm ineligible for award of a Government contract by virtue of [40 U.S.C. 3144\(b\)](#) or § 5.12(a).

c. The penalty for making false statements is prescribed in the U.S. Code, Title 18 Crimes and Criminal Procedure, [18 U.S.C. 1001](#).

11. Anti-retaliation. It is unlawful for any person to discharge, demote, intimidate, threaten, restrain, coerce, blacklist, harass, or in any other manner discriminate against, or to cause any person to discharge, demote, intimidate, threaten, restrain, coerce, blacklist, harass, or in any other manner discriminate against, any worker or job applicant for:

a. Notifying any contractor of any conduct which the worker reasonably believes constitutes a violation of the DBA, Related Acts, this part, or [29 CFR part 1](#) or [3](#);

b. Filing any complaint, initiating or causing to be initiated any proceeding, or otherwise asserting or seeking to assert on behalf of themselves or others any right or protection under the DBA, Related Acts, this part, or [29 CFR part 1](#) or [3](#);

c. Cooperating in any investigation or other compliance action, or testifying in any proceeding under the DBA, Related Acts, this part, or [29 CFR part 1](#) or [3](#); or

d. Informing any other person about their rights under the DBA, Related Acts, this part, or [29 CFR part 1](#) or [3](#).

V. CONTRACT WORK HOURS AND SAFETY STANDARDS ACT

Pursuant to 29 CFR 5.5(b), the following clauses apply to any Federal-aid construction contract in an amount in excess of \$100,000 and subject to the overtime provisions of the Contract Work Hours and Safety Standards Act. These clauses shall be inserted in addition to the clauses required by 29 CFR 5.5(a) or 29 CFR 4.6. As used in this paragraph, the terms laborers and mechanics include watchpersons and guards.

1. Overtime requirements. No contractor or subcontractor contracting for any part of the contract work which may require or involve the employment of laborers or mechanics shall require or permit any such laborer or mechanic in any workweek in which he or she is employed on such work to work in excess of forty hours in such workweek unless such laborer or mechanic receives compensation at a rate not less than one and one-half times the basic rate of pay for all hours worked in excess of forty hours in such workweek. 29 CFR 5.5.

2. Violation; liability for unpaid wages; liquidated damages. In the event of any violation of the clause set forth in paragraph 1. of this section the contractor and any subcontractor responsible therefor shall be liable for the unpaid wages and interest from the date of the underpayment. In addition, such contractor and subcontractor shall be liable to the United States (in the case of work done under contract for the District of Columbia or a territory, to such District or to such territory), for liquidated damages. Such liquidated damages shall be computed with respect to each individual laborer or

mechanic, including watchpersons and guards, employed in violation of the clause set forth in paragraph 1. of this section, in the sum currently provided in 29 CFR 5.5(b)(2)* for each calendar day on which such individual was required or permitted to work in excess of the standard workweek of forty hours without payment of the overtime wages required by the clause set forth in paragraph 1. of this section.

* \$31 as of January 15, 2023 (See 88 FR 88 FR 2210) as may be adjusted annually by the Department of Labor, pursuant to the Federal Civil Penalties Inflation Adjustment Act of 1990.

3. Withholding for unpaid wages and liquidated damages

a. *Withholding process.* The FHWA or the contracting agency may, upon its own action, or must, upon written request of an authorized representative of the Department of Labor, withhold or cause to be withheld from the contractor so much of the accrued payments or advances as may be considered necessary to satisfy the liabilities of the prime contractor or any subcontractor for any unpaid wages; monetary relief, including interest; and liquidated damages required by the clauses set forth in this section on this contract, any other Federal contract with the same prime contractor, or any other federally assisted contract subject to the Contract Work Hours and Safety Standards Act that is held by the same prime contractor (as defined in § 5.2). The necessary funds may be withheld from the contractor under this contract, any other Federal contract with the same prime contractor, or any other federally assisted contract that is subject to the Contract Work Hours and Safety Standards Act and is held by the same prime contractor, regardless of whether the other contract was awarded or assisted by the same agency, and such funds may be used to satisfy the contractor liability for which the funds were withheld.

b. *Priority to withheld funds.* The Department has priority to funds withheld or to be withheld in accordance with Section IV paragraph 2.a. or paragraph 3.a. of this section, or both, over claims to those funds by:

- (1) A contractor's surety(ies), including without limitation performance bond sureties and payment bond sureties;
- (2) A contracting agency for its procurement costs;
- (3) A trustee(s) (either a court-appointed trustee or a U.S. trustee, or both) in bankruptcy of a contractor, or a contractor's bankruptcy estate;
- (4) A contractor's assignee(s);
- (5) A contractor's successor(s); or
- (6) A claim asserted under the Prompt Payment Act, [31 U.S.C. 3901](#)–3907.

4. Subcontracts. The contractor or subcontractor must insert in any subcontracts the clauses set forth in paragraphs 1. through 5. of this section and a clause requiring the subcontractors to include these clauses in any lower tier subcontracts. The prime contractor is responsible for compliance by any subcontractor or lower tier subcontractor with the clauses set forth in paragraphs 1. through 5. In the

event of any violations of these clauses, the prime contractor and any subcontractor(s) responsible will be liable for any unpaid wages and monetary relief, including interest from the date of the underpayment or loss, due to any workers of lower-tier subcontractors, and associated liquidated damages and may be subject to debarment, as appropriate.

5. Anti-retaliation. It is unlawful for any person to discharge, demote, intimidate, threaten, restrain, coerce, blacklist, harass, or in any other manner discriminate against, or to cause any person to discharge, demote, intimidate, threaten, restrain, coerce, blacklist, harass, or in any other manner discriminate against, any worker or job applicant for:

a. Notifying any contractor of any conduct which the worker reasonably believes constitutes a violation of the Contract Work Hours and Safety Standards Act (CWHSSA) or its implementing regulations in this part;

b. Filing any complaint, initiating or causing to be initiated any proceeding, or otherwise asserting or seeking to assert on behalf of themselves or others any right or protection under CWHSSA or this part;

c. Cooperating in any investigation or other compliance action, or testifying in any proceeding under CWHSSA or this part; or

d. Informing any other person about their rights under CWHSSA or this part.

VI. SUBLETTING OR ASSIGNING THE CONTRACT

This provision is applicable to all Federal-aid construction contracts on the National Highway System pursuant to 23 CFR 635.116.

1. The contractor shall perform with its own organization contract work amounting to not less than 30 percent (or a greater percentage if specified elsewhere in the contract) of the total original contract price, excluding any specialty items designated by the contracting agency. Specialty items may be performed by subcontract and the amount of any such specialty items performed may be deducted from the total original contract price before computing the amount of work required to be performed by the contractor's own organization (23 CFR 635.116).

a. The term "perform work with its own organization" in paragraph 1 of Section VI refers to workers employed or leased by the prime contractor, and equipment owned or rented by the prime contractor, with or without operators. Such term does not include employees or equipment of a subcontractor or lower tier subcontractor, agents of the prime contractor, or any other assignees. The term may include payments for the costs of hiring leased employees from an employee leasing firm meeting all relevant Federal and State regulatory requirements. Leased employees may only be included in this term if the prime contractor meets all of the following conditions: (based on longstanding interpretation)

- (1) the prime contractor maintains control over the supervision of the day-to-day activities of the leased employees;
- (2) the prime contractor remains responsible for the quality of the work of the leased employees;

- (3) the prime contractor retains all power to accept or exclude individual employees from work on the project; and
- (4) the prime contractor remains ultimately responsible for the payment of predetermined minimum wages, the submission of payrolls, statements of compliance and all other Federal regulatory requirements.

b. "Specialty Items" shall be construed to be limited to work that requires highly specialized knowledge, abilities, or equipment not ordinarily available in the type of contracting organizations qualified and expected to bid or propose on the contract as a whole and in general are to be limited to minor components of the overall contract. 23 CFR 635.102.

2. Pursuant to 23 CFR 635.116(a), the contract amount upon which the requirements set forth in paragraph (1) of Section VI is computed includes the cost of material and manufactured products which are to be purchased or produced by the contractor under the contract provisions.

3. Pursuant to 23 CFR 635.116(c), the contractor shall furnish (a) a competent superintendent or supervisor who is employed by the firm, has full authority to direct performance of the work in accordance with the contract requirements, and is in charge of all construction operations (regardless of who performs the work) and (b) such other of its own organizational resources (supervision, management, and engineering services) as the contracting officer determines is necessary to assure the performance of the contract.

4. No portion of the contract shall be sublet, assigned or otherwise disposed of except with the written consent of the contracting officer, or authorized representative, and such consent when given shall not be construed to relieve the contractor of any responsibility for the fulfillment of the contract. Written consent will be given only after the contracting agency has assured that each subcontract is evidenced in writing and that it contains all pertinent provisions and requirements of the prime contract. (based on long-standing interpretation of 23 CFR 635.116).

5. The 30-percent self-performance requirement of paragraph (1) is not applicable to design-build contracts; however, contracting agencies may establish their own self-performance requirements. 23 CFR 635.116(d).

VII. SAFETY: ACCIDENT PREVENTION

This provision is applicable to all Federal-aid construction contracts and to all related subcontracts.

1. In the performance of this contract the contractor shall comply with all applicable Federal, State, and local laws governing safety, health, and sanitation (23 CFR Part 635). The contractor shall provide all safeguards, safety devices and protective equipment and take any other needed actions as it determines, or as the contracting officer may determine, to be reasonably necessary to protect the life and health of employees on the job and the safety of the public and to protect property in connection with the performance of the work covered by the contract. 23 CFR 635.108.

2. It is a condition of this contract, and shall be made a condition of each subcontract, which the contractor enters into pursuant to this contract, that the contractor and any subcontractor shall not permit any employee, in performance of the contract, to work in surroundings or under conditions which are unsanitary, hazardous or dangerous to his/her health or safety, as determined under construction safety and

health standards (29 CFR Part 1926) promulgated by the Secretary of Labor, in accordance with Section 107 of the Contract Work Hours and Safety Standards Act (40 U.S.C. 3704). 29 CFR 1926.10.

3. Pursuant to 29 CFR 1926.3, it is a condition of this contract that the Secretary of Labor or authorized representative thereof, shall have right of entry to any site of contract performance to inspect or investigate the matter of compliance with the construction safety and health standards and to carry out the duties of the Secretary under Section 107 of the Contract Work Hours and Safety Standards Act (40 U.S.C. 3704).

VIII. FALSE STATEMENTS CONCERNING HIGHWAY PROJECTS

This provision is applicable to all Federal-aid construction contracts and to all related subcontracts.

In order to assure high quality and durable construction in conformity with approved plans and specifications and a high degree of reliability on statements and representations made by engineers, contractors, suppliers, and workers on Federal-aid highway projects, it is essential that all persons concerned with the project perform their functions as carefully, thoroughly, and honestly as possible. Willful falsification, distortion, or misrepresentation with respect to any facts related to the project is a violation of Federal law. To prevent any misunderstanding regarding the seriousness of these and similar acts, Form FHWA-1022 shall be posted on each Federal-aid highway project (23 CFR Part 635) in one or more places where it is readily available to all persons concerned with the project:

18 U.S.C. 1020 reads as follows:

"Whoever, being an officer, agent, or employee of the United States, or of any State or Territory, or whoever, whether a person, association, firm, or corporation, knowingly makes any false statement, false representation, or false report as to the character, quality, quantity, or cost of the material used or to be used, or the quantity or quality of the work performed or to be performed, or the cost thereof in connection with the submission of plans, maps, specifications, contracts, or costs of construction on any highway or related project submitted for approval to the Secretary of Transportation; or

Whoever knowingly makes any false statement, false representation, false report or false claim with respect to the character, quality, quantity, or cost of any work performed or to be performed, or materials furnished or to be furnished, in connection with the construction of any highway or related project approved by the Secretary of Transportation; or

Whoever knowingly makes any false statement or false representation as to material fact in any statement, certificate, or report submitted pursuant to provisions of the Federal-aid Roads Act approved July 11, 1916, (39 Stat. 355), as amended and supplemented;

Shall be fined under this title or imprisoned not more than 5 years or both."

IX. IMPLEMENTATION OF CLEAN AIR ACT AND FEDERAL WATER POLLUTION CONTROL ACT (42 U.S.C. 7606; 2 CFR 200.88; EO 11738)

This provision is applicable to all Federal-aid construction contracts in excess of \$150,000 and to all related subcontracts. 48 CFR 2.101; 2 CFR 200.327.

By submission of this bid/proposal or the execution of this contract or subcontract, as appropriate, the bidder, proposer, Federal-aid construction contractor, subcontractor, supplier, or vendor agrees to comply with all applicable standards, orders or regulations issued pursuant to the Clean Air Act (42 U.S.C. 7401-7671q) and the Federal Water Pollution Control Act, as amended (33 U.S.C. 1251-1387). Violations must be reported to the Federal Highway Administration and the Regional Office of the Environmental Protection Agency. 2 CFR Part 200, Appendix II.

The contractor agrees to include or cause to be included the requirements of this Section in every subcontract, and further agrees to take such action as the contracting agency may direct as a means of enforcing such requirements. 2 CFR 200.327.

X. CERTIFICATION REGARDING DEBARMENT, SUSPENSION, INELIGIBILITY AND VOLUNTARY EXCLUSION

This provision is applicable to all Federal-aid construction contracts, design-build contracts, subcontracts, lower-tier subcontracts, purchase orders, lease agreements, consultant contracts or any other covered transaction requiring FHWA approval or that is estimated to cost \$25,000 or more – as defined in 2 CFR Parts 180 and 1200. 2 CFR 180.220 and 1200.220.

1. Instructions for Certification – First Tier Participants:

- a. By signing and submitting this proposal, the prospective first tier participant is providing the certification set out below.
- b. The inability of a person to provide the certification set out below will not necessarily result in denial of participation in this covered transaction. The prospective first tier participant shall submit an explanation of why it cannot provide the certification set out below. The certification or explanation will be considered in connection with the department or agency's determination whether to enter into this transaction. However, failure of the prospective first tier participant to furnish a certification or an explanation shall disqualify such a person from participation in this transaction. 2 CFR 180.320.
- c. The certification in this clause is a material representation of fact upon which reliance was placed when the contracting agency determined to enter into this transaction. If it is later determined that the prospective participant knowingly rendered an erroneous certification, in addition to other remedies available to the Federal Government, the contracting agency may terminate this transaction for cause of default. 2 CFR 180.325.
- d. The prospective first tier participant shall provide immediate written notice to the contracting agency to whom this proposal is submitted if any time the prospective first tier participant learns that its certification was erroneous when submitted or has become erroneous by reason of changed circumstances. 2 CFR 180.345 and 180.350.

e. The terms "covered transaction," "debarred," "suspended," "ineligible," "participant," "person," "principal," and "voluntarily excluded," as used in this clause, are defined in 2 CFR Parts 180, Subpart I, 180.900-180.1020, and 1200. "First Tier Covered Transactions" refers to any covered transaction between a recipient or subrecipient of Federal funds and a participant (such as the prime or general contract). "Lower Tier Covered Transactions" refers to any covered transaction under a First Tier Covered Transaction (such as subcontracts). "First Tier Participant" refers to the participant who has entered into a covered transaction with a recipient or subrecipient of Federal funds (such as the prime or general contractor). "Lower Tier Participant" refers any participant who has entered into a covered transaction with a First Tier Participant or other Lower Tier Participants (such as subcontractors and suppliers).

f. The prospective first tier participant agrees by submitting this proposal that, should the proposed covered transaction be entered into, it shall not knowingly enter into any lower tier covered transaction with a person who is debarred, suspended, declared ineligible, or voluntarily excluded from participation in this covered transaction, unless authorized by the department or agency entering into this transaction. 2 CFR 180.330.

g. The prospective first tier participant further agrees by submitting this proposal that it will include the clause titled "Certification Regarding Debarment, Suspension, Ineligibility and Voluntary Exclusion-Lower Tier Covered Transactions," provided by the department or contracting agency, entering into this covered transaction, without modification, in all lower tier covered transactions and in all solicitations for lower tier covered transactions exceeding the \$25,000 threshold. 2 CFR 180.220 and 180.300.

h. A participant in a covered transaction may rely upon a certification of a prospective participant in a lower tier covered transaction that is not debarred, suspended, ineligible, or voluntarily excluded from the covered transaction, unless it knows that the certification is erroneous. 2 CFR 180.300; 180.320, and 180.325. A participant is responsible for ensuring that its principals are not suspended, debarred, or otherwise ineligible to participate in covered transactions. 2 CFR 180.335. To verify the eligibility of its principals, as well as the eligibility of any lower tier prospective participants, each participant may, but is not required to, check the System for Award Management website (<https://www.sam.gov/>). 2 CFR 180.300, 180.320, and 180.325.

i. Nothing contained in the foregoing shall be construed to require the establishment of a system of records in order to render in good faith the certification required by this clause. The knowledge and information of the prospective participant is not required to exceed that which is normally possessed by a prudent person in the ordinary course of business dealings.

j. Except for transactions authorized under paragraph (f) of these instructions, if a participant in a covered transaction knowingly enters into a lower tier covered transaction with a person who is suspended, debarred, ineligible, or voluntarily excluded from participation in this transaction, in addition to other remedies available to the Federal Government, the department or agency may terminate this transaction for cause or default. 2 CFR 180.325.

2. Certification Regarding Debarment, Suspension, Ineligibility and Voluntary Exclusion – First Tier Participants:

a. The prospective first tier participant certifies to the best of its knowledge and belief, that it and its principals:

(1) Are not presently debarred, suspended, proposed for debarment, declared ineligible, or voluntarily excluded from participating in covered transactions by any Federal department or agency, 2 CFR 180.335;.

(2) Have not within a three-year period preceding this proposal been convicted of or had a civil judgment rendered against them for commission of fraud or a criminal offense in connection with obtaining, attempting to obtain, or performing a public (Federal, State, or local) transaction or contract under a public transaction; violation of Federal or State antitrust statutes or commission of embezzlement, theft, forgery, bribery, falsification or destruction of records, making false statements, or receiving stolen property, 2 CFR 180.800;

(3) Are not presently indicted for or otherwise criminally or civilly charged by a governmental entity (Federal, State or local) with commission of any of the offenses enumerated in paragraph (a)(2) of this certification, 2 CFR 180.700 and 180.800; and

(4) Have not within a three-year period preceding this application/proposal had one or more public transactions (Federal, State or local) terminated for cause or default. 2 CFR 180.335(d).

(5) Are not a corporation that has been convicted of a felony violation under any Federal law within the two-year period preceding this proposal (USDOT Order 4200.6 implementing appropriations act requirements); and

(6) Are not a corporation with any unpaid Federal tax liability that has been assessed, for which all judicial and administrative remedies have been exhausted, or have lapsed, and that is not being paid in a timely manner pursuant to an agreement with the authority responsible for collecting the tax liability (USDOT Order 4200.6 implementing appropriations act requirements).

b. Where the prospective participant is unable to certify to any of the statements in this certification, such prospective participant should attach an explanation to this proposal. 2 CFR 180.335 and 180.340.

3. Instructions for Certification - Lower Tier Participants:

(Applicable to all subcontracts, purchase orders, and other lower tier transactions requiring prior FHWA approval or estimated to cost \$25,000 or more - 2 CFR Parts 180 and 1200). 2 CFR 180.220 and 1200.220.

a. By signing and submitting this proposal, the prospective lower tier participant is providing the certification set out below.

b. The certification in this clause is a material representation of fact upon which reliance was placed when this transaction was entered into. If it is later determined that the prospective lower tier participant knowingly rendered an erroneous certification, in addition to other remedies available to the Federal Government, the department, or agency with which

this transaction originated may pursue available remedies, including suspension and/or debarment.

c. The prospective lower tier participant shall provide immediate written notice to the person to which this proposal is submitted if at any time the prospective lower tier participant learns that its certification was erroneous by reason of changed circumstances. 2 CFR 180.365.

d. The terms "covered transaction," "debarred," "suspended," "ineligible," "participant," "person," "principal," and "voluntarily excluded," as used in this clause, are defined in 2 CFR Parts 180, Subpart I, 180.900 – 180.1020, and 1200. You may contact the person to which this proposal is submitted for assistance in obtaining a copy of those regulations. "First Tier Covered Transactions" refers to any covered transaction between a recipient or subrecipient of Federal funds and a participant (such as the prime or general contractor). "Lower Tier Covered Transactions" refers to any covered transaction under a First Tier Covered Transaction (such as subcontracts). "First Tier Participant" refers to the participant who has entered into a covered transaction with a recipient or subrecipient of Federal funds (such as the prime or general contractor). "Lower Tier Participant" refers any participant who has entered into a covered transaction with a First Tier Participant or other Lower Tier Participants (such as subcontractors and suppliers).

e. The prospective lower tier participant agrees by submitting this proposal that, should the proposed covered transaction be entered into, it shall not knowingly enter into any lower tier covered transaction with a person who is debarred, suspended, declared ineligible, or voluntarily excluded from participation in this covered transaction, unless authorized by the department or agency with which this transaction originated. 2 CFR 1200.220 and 1200.332.

f. The prospective lower tier participant further agrees by submitting this proposal that it will include this clause titled "Certification Regarding Debarment, Suspension, Ineligibility and Voluntary Exclusion-Lower Tier Covered Transaction," without modification, in all lower tier covered transactions and in all solicitations for lower tier covered transactions exceeding the \$25,000 threshold. 2 CFR 180.220 and 1200.220.

g. A participant in a covered transaction may rely upon a certification of a prospective participant in a lower tier covered transaction that is not debarred, suspended, ineligible, or voluntarily excluded from the covered transaction, unless it knows that the certification is erroneous. A participant is responsible for ensuring that its principals are not suspended, debarred, or otherwise ineligible to participate in covered transactions. To verify the eligibility of its principals, as well as the eligibility of any lower tier prospective participants, each participant may, but is not required to, check the System for Award Management website (<https://www.sam.gov/>), which is compiled by the General Services Administration. 2 CFR 180.300, 180.320, 180.330, and 180.335.

h. Nothing contained in the foregoing shall be construed to require establishment of a system of records in order to render in good faith the certification required by this clause. The knowledge and information of participant is not required to exceed that which is normally possessed by a prudent person in the ordinary course of business dealings.

i. Except for transactions authorized under paragraph e of these instructions, if a participant in a covered transaction knowingly enters into a lower tier covered transaction with a person who is suspended, debarred, ineligible, or voluntarily

excluded from participation in this transaction, in addition to other remedies available to the Federal Government, the department or agency with which this transaction originated may pursue available remedies, including suspension and/or debarment. 2 CFR 180.325.

4. Certification Regarding Debarment, Suspension, Ineligibility and Voluntary Exclusion--Lower Tier Participants:

a. The prospective lower tier participant certifies, by submission of this proposal, that neither it nor its principals:

(1) is presently debarred, suspended, proposed for debarment, declared ineligible, or voluntarily excluded from participating in covered transactions by any Federal department or agency, 2 CFR 180.355;

(2) is a corporation that has been convicted of a felony violation under any Federal law within the two-year period preceding this proposal (USDOT Order 4200.6 implementing appropriations act requirements); and

(3) is a corporation with any unpaid Federal tax liability that has been assessed, for which all judicial and administrative remedies have been exhausted, or have lapsed, and that is not being paid in a timely manner pursuant to an agreement with the authority responsible for collecting the tax liability. (USDOT Order 4200.6 implementing appropriations act requirements)

b. Where the prospective lower tier participant is unable to certify to any of the statements in this certification, such prospective participant should attach an explanation to this proposal.

XI. CERTIFICATION REGARDING USE OF CONTRACT FUNDS FOR LOBBYING

This provision is applicable to all Federal-aid construction contracts and to all related subcontracts which exceed \$100,000. 49 CFR Part 20, App. A.

1. The prospective participant certifies, by signing and submitting this bid or proposal, to the best of his or her knowledge and belief, that:

a. No Federal appropriated funds have been paid or will be paid, by or on behalf of the undersigned, to any person for influencing or attempting to influence an officer or employee of any Federal agency, a Member of Congress, an officer or employee of Congress, or an employee of a Member of Congress in connection with the awarding of any Federal contract, the making of any Federal grant, the making of any Federal loan, the entering into of any cooperative agreement, and the extension, continuation, renewal, amendment, or modification of any Federal contract, grant, loan, or cooperative agreement.

b. If any funds other than Federal appropriated funds have been paid or will be paid to any person for influencing or attempting to influence an officer or employee of any Federal agency, a Member of Congress, an officer or employee of Congress, or an employee of a Member of Congress in connection with this Federal contract, grant, loan, or

cooperative agreement, the undersigned shall complete and submit Standard Form-LLL, "Disclosure Form to Report Lobbying," in accordance with its instructions.

2. This certification is a material representation of fact upon which reliance was placed when this transaction was made or entered into. Submission of this certification is a prerequisite for making or entering into this transaction imposed by 31 U.S.C. 1352. Any person who fails to file the required certification shall be subject to a civil penalty of not less than \$10,000 and not more than \$100,000 for each such failure.

3. The prospective participant also agrees by submitting its bid or proposal that the participant shall require that the language of this certification be included in all lower tier subcontracts, which exceed \$100,000 and that all such recipients shall certify and disclose accordingly.

XII. USE OF UNITED STATES-FLAG VESSELS:

This provision is applicable to all Federal-aid construction contracts, design-build contracts, subcontracts, lower-tier subcontracts, purchase orders, lease agreements, or any other covered transaction. 46 CFR Part 381.

This requirement applies to material or equipment that is acquired for a specific Federal-aid highway project. 46 CFR 381.7. It is not applicable to goods or materials that come into inventories independent of an FHWA funded-contract.

When oceanic shipments (or shipments across the Great Lakes) are necessary for materials or equipment acquired for a specific Federal-aid construction project, the bidder, proposer, contractor, subcontractor, or vendor agrees:

1. To utilize privately owned United States-flag commercial vessels to ship at least 50 percent of the gross tonnage (computed separately for dry bulk carriers, dry cargo liners, and tankers) involved, whenever shipping any equipment, material, or commodities pursuant to this contract, to the extent such vessels are available at fair and reasonable rates for United States-flag commercial vessels. 46 CFR 381.7.

2. To furnish within 20 days following the date of loading for shipments originating within the United States or within 30 working days following the date of loading for shipments originating outside the United States, a legible copy of a rated, 'on-board' commercial ocean bill-of-lading in English for each shipment of cargo described in paragraph (b)(1) of this section to both the Contracting Officer (through the prime contractor in the case of subcontractor bills-of-lading) and to the Office of Cargo and Commercial Sealift (MAR-620), Maritime Administration, Washington, DC 20590. (MARAD requires copies of the ocean carrier's (master) bills of lading, certified onboard, dated, with rates and charges. These bills of lading may contain business sensitive information and therefore may be submitted directly to MARAD by the Ocean Transportation Intermediary on behalf of the contractor). 46 CFR 381.7.

**ATTACHMENT A - EMPLOYMENT AND MATERIALS
PREFERENCE FOR APPALACHIAN DEVELOPMENT
HIGHWAY SYSTEM OR APPALACHIAN LOCAL ACCESS
ROAD CONTRACTS (23 CFR 633, Subpart B, Appendix B)**

This provision is applicable to all Federal-aid projects funded under the Appalachian Regional Development Act of 1965.

1. During the performance of this contract, the contractor undertaking to do work which is, or reasonably may be, done as on-site work, shall give preference to qualified persons who regularly reside in the labor area as designated by the DOL wherein the contract work is situated, or the subregion, or the Appalachian counties of the State wherein the contract work is situated, except:

a. To the extent that qualified persons regularly residing in the area are not available.

b. For the reasonable needs of the contractor to employ supervisory or specially experienced personnel necessary to assure an efficient execution of the contract work.

c. For the obligation of the contractor to offer employment to present or former employees as the result of a lawful collective bargaining contract, provided that the number of nonresident persons employed under this subparagraph (1c) shall not exceed 20 percent of the total number of employees employed by the contractor on the contract work, except as provided in subparagraph (4) below.

2. The contractor shall place a job order with the State Employment Service indicating (a) the classifications of the laborers, mechanics and other employees required to perform the contract work, (b) the number of employees required in each classification, (c) the date on which the participant estimates such employees will be required, and (d) any other pertinent information required by the State Employment Service to complete the job order form. The job order may be placed with the State Employment Service in writing or by telephone. If during the course of the contract work, the information submitted by the contractor in the original job order is substantially modified, the participant shall promptly notify the State Employment Service.

3. The contractor shall give full consideration to all qualified job applicants referred to him by the State Employment Service. The contractor is not required to grant employment to any job applicants who, in his opinion, are not qualified to perform the classification of work required.

4. If, within one week following the placing of a job order by the contractor with the State Employment Service, the State Employment Service is unable to refer any qualified job applicants to the contractor, or less than the number requested, the State Employment Service will forward a certificate to the contractor indicating the unavailability of applicants. Such certificate shall be made a part of the contractor's permanent project records. Upon receipt of this certificate, the contractor may employ persons who do not normally reside in the labor area to fill positions covered by the certificate, notwithstanding the provisions of subparagraph (1c) above.

5. The provisions of 23 CFR 633.207(e) allow the contracting agency to provide a contractual preference for the use of mineral resource materials native to the Appalachian region.

6. The contractor shall include the provisions of Sections 1 through 4 of this Attachment A in every subcontract for work which is, or reasonably may be, done as on-site work.

The United States Department of Transportation (USDOT)

Standard Title VI/Non-Discrimination Assurances

DOT Order No. 1050.2A

The **Maine Department of Transportation** (herein referred to as the "Recipient"), **HEREBY AGREES THAT**, as a condition to receiving any Federal financial assistance from the U.S. Department of Transportation (DOT), through **Federal Highway Administration** (herein referred to as "FHWA" is subject to and will comply with the following:

Statutory/Regulatory Authorities

- Title VI of the Civil Rights Act of 1964 (42 U.S.C. § 2000d *et seq.*, 78 stat. 252), (prohibits discrimination on the basis of race, color, national origin);
- 49 C.F.R. Part 21 (entitled *Non-discrimination In Federally-Assisted Programs Of The Department Of Transportation-Effectuation Of Title VI Of The Civil Rights Act Of 1964*);
- 28 C.F.R. section 50.3 (U.S. Department of Justice Guidelines for Enforcement of Title VI of the Civil Rights Act of 1964);

The preceding statutory and regulatory cites hereinafter are referred to as the "Acts" and "Regulations," respectively.

General Assurances

In accordance with the Acts, the Regulations, and other pertinent directives, circulars, policy, memoranda, and/or guidance, the Recipient hereby gives assurance that it will promptly take any measures necessary to ensure that:

"No person in the United States shall, on the grounds of race, color, or national origin, be excluded from participation in, be denied the benefits of, or be otherwise subjected to discrimination under any program or activity, for which the Recipient receives Federal financial assistance from DOT, including the FHWA.

The Civil Rights Restoration Act of 1987 clarified the original intent of Congress, with respect to Title VI and other Non-discrimination requirements (The Age Discrimination Act of 1975, and Section 504 of the Rehabilitation Act of 1973), by restoring the broad, institutional-wide scope and coverage of these non-discrimination statutes and requirements to include all programs and activities of the Recipient, so long as any portion of the program is Federally assisted.

Specific Assurances

More specifically, and without limiting the above general Assurance, the Recipient agrees with and gives the following Assurances with respect to its Federally assisted **FHWA Program**.

1. The Recipient agrees that each "activity," "facility," or "program," as defined in §§ 21.23(b) and 21.2(e) of 49 C.F.R. § 21 will be (with regard to an "activity") facilitated, or will be (with regard to a "facility") operated, or will be (with regard to a "program") conducted in compliance with all requirements imposed by, or pursuant to the Acts and the Regulations.
2. The Recipient will insert the following notification in all solicitations for bids, Requests For Proposals for work, or material subject to the Acts and the Regulations made in connection with all **FHWA Programs** and, in adapted form, in all proposals for negotiated agreements regardless of funding source:

"The Maine Department of Transportation, in accordance with the provisions of Title VI of the Civil Rights Act of 1964 (78 Stat. 252, 42 U.S.C. §§ 2000d to 2000d-4) and the Regulations, hereby notifies all bidders that it will affirmatively ensure that any contract entered into pursuant to this advertisement, disadvantaged business enterprises will be afforded full and fair opportunity to submit bids in response to this invitation and will not be discriminated against on the grounds of race, color, or national origin in consideration for an award."
3. The Recipient will insert the clauses of Appendix A and E of this Assurance in every contract or agreement subject to the Acts and the Regulations.
4. The Recipient will insert the clauses of Appendix B of this Assurance, as a covenant running with the land, in any deed from the United States effecting or recording a transfer of real property, structures, use, or improvements thereon or interest therein to a Recipient.
5. That where the Recipient receives Federal financial assistance to construct a facility, or part of a facility, the Assurance will extend to the entire facility and facilities operated in connection therewith.
6. That where the Recipient receives Federal financial assistance in the form, or for the acquisition of real property or an interest in real property, the Assurance will extend to rights to space on, over, or under such property.
7. That the Recipient will include the clauses set forth in Appendix C and Appendix D of this Assurance, as a covenant running with the land, in any future deeds,

leases, licenses, permits, or similar instruments entered into by the Recipient with other parties:

- a. for the subsequent transfer of real property acquired or improved under the applicable activity, project, or program; and
 - b. for the construction or use of, or access to, space on, over, or under real property acquired or improved under the applicable activity, project, or program.
8. That this Assurance obligates the Recipient for the period during which Federal financial assistance is extended to the program, except where the Federal financial assistance is to provide, or is in the form of, personal property, or real property, or interest therein, or structures or improvements thereon, in which case the Assurance obligates the Recipient, or any transferee for the longer of the following periods:
- A. the period during which the property is used for a purpose for which the Federal financial assistance is extended, or for another purpose involving the provision of similar services or benefits; or
 - b. the period during which the Recipient retains ownership or possession of the property.
9. The Recipient will provide for such methods of administration for the program as are found by the Secretary of Transportation or the official to whom he/she delegates specific authority to give reasonable guarantee that it, other recipients, sub-recipients, sub-grantees, contractors, subcontractors, consultants, transferees, successors in interest, and other participants of Federal financial assistance under such program will comply with all requirements imposed or pursuant to the Acts, the Regulations, and this Assurance.
10. The Recipient agrees that the United States has a right to seek judicial enforcement with regard to any matter arising under the Acts, the Regulations, and this Assurance.

By signing this ASSURANCE, **Maine Department of Transportation** also agrees to comply (and require any sub-recipients, sub-grantees, contractors, successors, transferees, and/or assignees to comply) with all applicable provisions governing the **FHWA's** access to records, accounts, documents, information, facilities, and staff. You also recognize that you must comply with any program or compliance reviews, and/or complaint investigations conducted by the **FHWA**. You must keep records, reports, and submit the material for review upon request to **FHWA** or its designee in a timely, complete, and accurate way. Additionally, you must comply with all other reporting, data collection, and evaluation requirements, as prescribed by law or detailed in program guidance.

APPENDIX A

During the performance of this contract, the contractor, for itself, its assignees, and successors in interest (hereinafter referred to as the "contractor") agrees as follows:

1. **Compliance with Regulations:** The contractor (hereinafter includes consultants) will comply with the Acts and the Regulations relative to Non-discrimination in Federally-assisted programs of the U.S. Department of Transportation, **Federal Aviation Administration (FHWA)**, as they may be amended from time to time, which are herein incorporated by reference and made a part of this contract.
2. **Non-discrimination:** The contractor, with regard to the work performed by it during the contract, will not discriminate on the grounds of race, color, or national origin in the selection and retention of subcontractors, including procurements of materials and leases of equipment. The contractor will not participate directly or indirectly in the discrimination prohibited by the Acts and the Regulations, including employment practices when the contract covers any activity, project, or program set forth in Appendix B of 49 CFR Part 21.
3. **Solicitations for Subcontracts, Including Procurements of Materials and Equipment:** In all solicitations, either by competitive bidding, or negotiation made by the contractor for work to be performed under a subcontract, including procurements of materials, or leases of equipment, each potential subcontractor or supplier will be notified by the contractor of the contractor's obligations under this contract and the Acts and the Regulations relative to Non-discrimination on the grounds of race, color, or national origin.
4. **Information and Reports:** The contractor will provide all information and reports required by the Acts, the Regulations, and directives issued pursuant thereto and will permit access to its books, records, accounts, other sources of information, and its facilities as may be determined by the Recipient or the **FHWA** to be pertinent to ascertain compliance with such Acts, Regulations, and instructions. Where any information required of a contractor is in the exclusive possession of another who fails or refuses to furnish the information, the contractor will so certify to the Recipient or the **FHWA** as appropriate, and will set forth what efforts it has made to obtain the information.
5. **Sanctions for Noncompliance:** In the event of a contractor's noncompliance with the Non- discrimination provisions of this contract, the Recipient will impose such contract sanctions as it or the **FHWA** may determine to be appropriate, including, but not limited to:

- a. withholding payments to the contractor under the contract until the contractor complies; and/or
 - b. cancelling, terminating, or suspending a contract, in whole or in part.
6. **Incorporation of Provisions:** The contractor will include the provisions of paragraphs one through six in every subcontract, including procurements of materials and leases of equipment, unless exempt by the Acts, the Regulations and directives issued pursuant thereto. The contractor will take action with respect to any subcontract or procurement as the Recipient or the FHWA may direct as a means of enforcing such provisions including sanctions for noncompliance. Provided, that if the contractor becomes involved in, or is threatened with litigation by a subcontractor, or supplier because of such direction, the contractor may request the Recipient to enter into any litigation to protect the interests of the Recipient. In addition, the contractor may request the United States to enter into the litigation to protect the interests of the United States.

APPENDIX B

CLAUSES FOR DEEDS TRANSFERRING UNITED STATES PROPERTY

The following clauses will be included in deeds effecting or recording the transfer of real property, structures, or improvements thereon, or granting interest therein from the United States pursuant to the provisions of Assurance 4:

NOW, THEREFORE, the U.S. Department of Transportation as authorized by law and upon the condition that the **Maine Department of Transportation** will accept title to the lands and maintain the project constructed thereon in accordance with all requirements imposed by Title 49, Code of Federal Regulations, Department of Transportation, subtitle A, Office of the Secretary, part 21, Non-discrimination in Federally-assisted Programs of the Department of Transportation pertaining to and effectuating the provisions of Title VI of the Civil Rights Act of 1964 (78 Stat. 252; 42 U.S.C. § 2000d to 2000d-4), the Regulations for the Administration of **Federal Aviation Administration (FHWA) Program**, and the policies and procedures prescribed by the **FHWA** of the U.S. Department of Transportation in accordance and in compliance with all requirements imposed by Title 49, Code of Federal Regulations, U.S. Department of Transportation, Subtitle A, Office of the Secretary, Part 21, Non-discrimination in Federally-assisted programs of the U.S Department of Transportation pertaining to and effectuating the provisions of Title VI of the Civil Rights Act of 1964 (78 Stat. 252; 42 U.S.C. § 2000d to 2000d-4), does hereby remise, release, quitclaim and convey unto the **Maine Department of Transportation** all the right, title and interest of the U.S. Department of Transportation in and to said lands described in Exhibit A attached hereto and made a part hereof.

(HABENDUM CLAUSE)

TO HAVE AND TO HOLD said lands and interests therein unto **Maine Department of Transportation** and its successors forever, subject, however, to the covenants, conditions, restrictions and reservations herein contained as follows, which will remain in effect for the period during which the real property or structures are used for a purpose for which Federal financial assistance is extended or for another purpose involving the provision of similar services or benefits and will be binding on the **Maine Department of Transportation**, its successors and assigns.

The **Maine Department of Transportation**, in consideration of the conveyance of said lands and interests in lands, does hereby covenant and agree as a covenant running with the land for itself, its successors and assigns, that (1) no person will on the grounds of race, color, or national origin, be excluded from participation in, be denied the benefits of, or be otherwise subjected to discrimination with regard to any facility located wholly or in part on, over, or under such lands hereby conveyed [,] [and]* (2) that the **Maine Department of Transportation** will use the lands and interests in lands and interests in lands so conveyed, in compliance with all requirements imposed by or pursuant to Title 49, Code of Federal Regulations, U.S. Department of Transportation, Subtitle A, Office of the Secretary, Part 21, Non- discrimination in Federally-assisted programs of the U.S. Department of Transportation, Effectuation of Title VI of the Civil Rights Act of 1964, and as said Regulations and Acts may be amended[, and (3) that in the event of breach of any of the above-mentioned non-discrimination conditions, the Department will have a right to enter or re-enter said lands and facilities on said land, and that above described land and facilities will thereon revert to and vest in and become the absolute property of the U.S. Department of Transportation

and its assigns as such interest existed prior to this instruction].*

(*Reverter clause and related language to be used only when it is determined that such a clause is necessary in order to make clear the purpose of Title VI.)

APPENDIX C

CLAUSES FOR TRANSFER OF REAL PROPERTY ACQUIRED OR IMPROVED UNDER THE ACTIVITY, FACILITY, OR PROGRAM

The following clauses will be included in deeds, licenses, leases, permits, or similar instruments entered into by the **Maine Department of Transportation** pursuant to the provisions of Assurance 7(a):

- A. The (grantee, lessee, permittee, etc. as appropriate) for himself/herself, his/her heirs, personal representatives, successors in interest, and assigns, as a part of the consideration hereof, does hereby covenant and agree [in the case of deeds and leases add "as a covenant running with the land"] that:
 1. In the event facilities are constructed, maintained, or otherwise operated on the property described in this (deed, license, lease, permit, etc.) for a purpose for which a U.S. Department of Transportation activity, facility, or program is extended or for another purpose involving the provision of similar services or benefits, the (grantee, licensee, lessee, permittee, etc.) will maintain and operate such facilities and services in compliance with all requirements imposed by the Acts and Regulations (as may be amended) such that no person on the grounds of race, color, or national origin, will be excluded from participation in, denied the benefits of, or be otherwise subjected to discrimination in the use of said facilities.
- B. With respect to licenses, leases, permits, etc., in the event of breach of any of the above Non-discrimination covenants, **Maine Department of Transportation** will have the right to terminate the (lease, license, permit, etc.) and to enter, re-enter, and repossess said lands and facilities thereon, and hold the same as if the (lease, license, permit, etc.) had never been made or issued.*
- C. With respect to a deed, in the event of breach of any of the above Non-discrimination covenants, the **Maine Department of Transportation** will have the right to enter or re-enter the lands and facilities thereon, and the above described lands and facilities will there upon revert to and vest in and become the absolute property of the **Maine Department of Transportation** and its assigns.*

(*Reverter clause and related language to be used only when it is determined that such a clause is necessary to make clear the purpose of Title VI.)

APPENDIX D

CLAUSES FOR CONSTRUCTION/USE/ACCESS TO REAL PROPERTY ACQUIRED UNDER THE ACTIVITY, FACILITY OR PROGRAM

The following clauses will be included in deeds, licenses, permits, or similar instruments/agreements entered into by **Maine Department of Transportation** pursuant to the provisions of Assurance 7(b):

- A. The (grantee, licensee, permittee, etc., as appropriate) for himself/herself, his/her heirs, personal representatives, successors in interest, and assigns, as a part of the consideration hereof, does hereby covenant and agree (in the case of deeds and leases add, "as a covenant running with the land") that (1) no person on the ground of race, color, or national origin, will be excluded from participation in, denied the benefits of, or be otherwise subjected to discrimination in the use of said facilities, (2) that in the construction of any improvements on, over, or under such land, and the furnishing of services thereon, no person on the ground of race, color, or national origin, will be excluded from participation in, denied the benefits of, or otherwise be subjected to discrimination, (3) that the (grantee, licensee, lessee, permittee, etc.) will use the premises in compliance with all other requirements imposed by or pursuant to the Acts and Regulations, as amended, set forth in this Assurance.
- B. With respect to (licenses, leases, permits, etc.), in the event of breach of any of the above Non-discrimination covenants, **Maine Department of Transportation** will have the right to terminate the (license, permit, etc., as appropriate) and to enter or re-enter and repossess said land and the facilities thereon, and hold the same as if said (license, permit, etc., as appropriate) had never been made or issued.*
- C. With respect to deeds, in the event of breach of any of the above Non-discrimination covenants, **Maine Department of Transportation** will there upon revert to and vest in and become the absolute property of **Maine Department of Transportation** and its assigns.*

(*Reverter clause and related language to be used only when it is determined that such a clause is necessary to make clear the purpose of Title VI.)

APPENDIX E

During the performance of this contract, the contractor, for itself, its assignees, and successors in interest (hereinafter referred to as the "contractor") agrees to comply with the following non-discrimination statutes and authorities; including but not limited to:

Pertinent Non-Discrimination Authorities:

- Title VI of the Civil Rights Act of 1964 (42 U.S.C. § 2000d *et seq.*, 78 stat. 252), (prohibits discrimination on the basis of race, color, national origin); and 49 CFR Part 21.
- The Uniform Relocation Assistance and Real Property Acquisition Policies Act of 1970, (42 U.S.C. § 4601), (prohibits unfair treatment of persons displaced or whose property has been acquired because of Federal or Federal-aid programs and projects);
- Federal-Aid Highway Act of 1973, (23 U.S.C. § 324 *et seq.*), (prohibits discrimination on the basis of sex);
- Section 504 of the Rehabilitation Act of 1973, (29 U.S.C. § 794 *et seq.*), as amended, (prohibits discrimination on the basis of disability); and 49 CFR Part 27;
- The Age Discrimination Act of 1975, as amended, (42 U.S.C. § 6101 *et seq.*), (prohibits discrimination on the basis of age);
- Airport and Airway Improvement Act of 1982, (49 USC § 471, Section 47123), as amended, (prohibits discrimination based on race, creed, color, national origin, or sex);
- The Civil Rights Restoration Act of 1987, (PL 100-209), (Broadened the scope, coverage and applicability of Title VI of the Civil Rights Act of 1964, The Age Discrimination Act of 1975 and Section 504 of the Rehabilitation Act of 1973, by expanding the definition of the terms "programs or activities" to include all of the programs or activities of the Federal-aid recipients, sub-recipients and contractors, whether such programs or activities are Federally funded or not);
- Titles II and III of the Americans with Disabilities Act, which prohibit discrimination on the basis of disability in the operation of public entities, public and private transportation systems, places of public accommodation, and certain testing entities (42 U.S.C. §§ 12131-12189) as implemented by Department of Transportation regulations at 49 C.F.R. parts 37 and 38;
- The Federal Aviation Administration's Non-discrimination statute (49 U.S.C. § 47123) (prohibits discrimination on the basis of race, color, national origin, and sex);
- Executive Order 12898, Federal Actions to Address Environmental Justice in Minority Populations and Low-Income Populations, which ensures discrimination against minority populations by discouraging programs, policies, and activities with disproportionately high and adverse human health or environmental effects on minority and low-income populations;
- Executive Order 13166, Improving Access to Services for Persons with Limited English Proficiency, and resulting agency guidance, national origin discrimination includes discrimination because of limited English proficiency (LEP). To ensure

compliance with Title VI, you must take reasonable steps to ensure that LEP persons have meaningful access to your programs (70 Fed. Reg. at 74087 to 74100);

- Title IX of the Education Amendments of 1972, as amended, which prohibits you from discriminating because of sex in education programs or activities (20 U.S.C. 1681 et seq).



Environmental Summary Sheet

WIN: 25751.00

Date Submitted: 7/22/2025

Town: Augusta

CPD Team Leader: Danielle Tetreau

ENV Field Contact: Valerie Derosier

NEPA Complete: Section 326 MOU Categorical Exclusion (CE) 23 CFR 771.117.c.26 issued on 3/10/2025

Section 106

Review Complete: PA-B Approved 4/26/2023

Section 106 Resources: none

Section 4(f) and 6(f)

Section 4(f)

Review Complete - No use

Section 6(f)

Review Complete - No takes

Section 7 – Endangered Species Act

Species of Concern: northern long-eared bat: Formal Consultation - likely to adversely affect

Tri-colored bat: proposed for listing, no jeopardy.

**See SP 105 for Environmental Requirements.*

Essential Fish Habitat

Species of Concern: Atlantic salmon – No Effect - no in-water work proposed

Maine Department of Inland Fisheries and Wildlife

Not Applicable

Timing Window: Not Applicable

Maine Department of Agriculture, Conservation, and Forestry

Public Lands, Submerged Land Lease: Not Applicable

Maine Land Use Planning Commission: Not Applicable

Maine Department of Environmental Protection

Not Applicable – no resource impacts

Army Corps of Engineers: Clean Water Act.

Not Applicable - no resource impacts

Stormwater Review

Review Complete

Hazardous Material Review

Review complete – SP 203 for Requirements at the following locations:

Station 5001+00 to Station 5004+00

Station 5020+50 to Sta. 5023+00

Station 5027+00 to Sta. 5029+00 and Station 6000+00 to Sta. 6001+00



Special Provisions Required

Standard Specification 656-Erosion Control Plan

N/A

Applicable

Special Provision 105-Environmental Requirements

N/A

Applicable

Special Provision 203-Hazardous Materials

N/A

Applicable

Special Provision 656-Minor Soil Disturbance

N/A

Applicable

Special Provision 203-Dredge Spec

N/A

Applicable

General Note for Hazardous Waste

N/A

Applicable

*All permits and approvals based on plans/scope as of: 10/21/2024



Environmental Summary Sheet

WIN: 028356.00

Date Submitted: 3/5/2026

Town: Augusta, Route 202

CPD Team Leader: Joshua Brown

ENV Field Contact: Hannah Johnson

NEPA Complete: NEPA certified on 3/5/2026, pursuant to 23 CFE 771.117(c)(26).

Section 106

Review Complete: PA-A, No Effect 11/22/2026

Section 106 Resources: none

Section 4(f) and 6(f)

Section 4(f)

No ROW/no use

Section 6(f)

No ROW/no takes

Maine Department of Inland Fisheries and Wildlife Essential Habitat

None present

Section 7

Species of Concern: Atlantic Salmon – No Effect
Northern Long-Eared Bat - NLAA

Essential Fish Habitat

Atlantic Salmon- No Effect

Maine Department of Agriculture, Conservation, and Forestry

Public Lands, Submerged Land Lease: NA

Maine Land Use Planning Commission: NA

Maine Department of Environmental Protection

NA, exempt activity

Army Corps of Engineers: Section 10 of the Rivers and Harbors Act and Section 404 of the Clean Water Act.

NA, exempt activity

Stormwater Review

NA- scope

Hazardous Materials Review

No HAZ based on scope

Special Provisions Required

Special Provision 105-Environmental Requirements	N/A <input type="checkbox"/>	Applicable <input checked="" type="checkbox"/>
Special Provision 203-Dredge material	N/A <input checked="" type="checkbox"/>	Applicable <input type="checkbox"/>
Standard Specification 656-Erosion Control Plan	N/A <input type="checkbox"/>	Applicable <input checked="" type="checkbox"/>
Special Provision 656-Minor Soil Disturbance	N/A <input checked="" type="checkbox"/>	Applicable <input type="checkbox"/>
Special Provision 203-Dredge Spec	N/A <input checked="" type="checkbox"/>	Applicable <input type="checkbox"/>

*All permits and approvals based on plans/scope as of: 3/3/2026