

Updated 04/28/17

STATE PROJECT

BIDDING INSTRUCTIONS

FOR ALL PROJECTS:

1. Use pen and ink to complete all paper Bids.
2. As a minimum, the following must be received prior to the time of Bid opening:

For a Paper Bid:

- a) a copy of the Notice to Contractors, b) the completed Acknowledgement of Bid Amendments form, c) the completed Schedule of Items, d) two copies of the completed and signed Contract Offer, Agreement & Award form, e) a Bid Guaranty, (if required), and f) any other certifications or Bid requirements listed in the Bid Documents as due by Bid opening.

For an Electronic Bid:

- a) a completed Bid using Expedite® software and submitted via the Bid Express™ web-based service, b) an electronic Bid Guaranty (if required) or a faxed copy of a Bid Bond (with original to be delivered within 72 hours), and c) any other Certifications or Bid requirements listed in the Bid Documents as due by Bid opening.
3. Include prices for all items in the Schedule of Items (excluding non-selected alternates).
4. Bid Guaranty acceptable forms are:
 - a) a properly completed and signed Bid Bond on the Department's prescribed form (or on a form that does not contain any significant variations from the Department's form as determined by the Department) for 5% of the Bid Amount or
 - b) an Official Bank Check, Cashier's Check, Certified Check, U.S. Postal Money Order or Negotiable Certificate of Deposit in the amount stated in the Notice to Contractors or
 - c) an electronic bid bond submitted with an electronic bid.
5. If a paper Bid is to be sent, "FedEx First Overnight" delivery is suggested as the package is delivered directly to the DOT Headquarters Building located at 16 Child Street in Augusta. Other means, such as U.S. Postal Service's Express Mail has proven not to be reliable.

IN ADDITION, FOR FEDERAL AID PROJECTS:

6. Complete the DBE Proposed Utilization form, and submit with your bid. If you are submitting your bid electronically, you must FAX the form to (207) 624-3431. This is a curable defect.

*If you need further information regarding Bid preparation, call the DOT
Contracts Section at (207) 624-3410.*

*For complete bidding requirements, refer to Section 102 of the Maine Department
of Transportation, Standard Specifications, November 2014 Edition.*

NOTICE

The Maine Department of Transportation is attempting to improve the way Bid Amendments/Addendums are handled, and allow for an electronic downloading of bid packages from our website, while continuing to maintain an optional plan holders list.

Prospective bidders, subcontractors or suppliers who wish to download a copy of the bid package and receive a courtesy notification of project specific bid amendments must fill out the on-line plan holder registration form and provide an email address to the MDOT Contracts mailbox at: MDOT.contracts@maine.gov. Each bid package will require a separate request.

Additionally, interested parties will be responsible for reviewing and retrieving the Bid Amendments from our web site, and acknowledging receipt and incorporating those Bid Amendments in their bids using the Acknowledgement of Bid Amendment Form.

The downloading of bid packages from the MDOT website is not the same as providing an electronic bid to the Department. Electronic bids must be submitted via <http://www.BIDX.com>. For information on electronic bidding contact Rebecca Snowden at rebecca.snowden@maine.gov or Diane Barnes at diane.barnes@maine.gov.

NOTICE

For security and other reasons, all Bid Packages which are mailed, shall be provided in double (one envelope inside the other) envelopes. The *Inner Envelope* shall have the following information provided on it:

Bid Enclosed - Do Not Open

PIN:

Town:

Date of Bid Opening:

Name of Contractor with mailing address and telephone number:

In Addition to the usual address information, the *Outer Envelope* should have written or typed on it:

Double Envelope: Bid Enclosed

PIN:

Town:

Date of Bid Opening:

Name of Contractor:

This should not be much of a change for those of you who use Federal Express or similar services.

Hand-carried Bids may be in one envelope as before, and should be marked with the following information:

Bid Enclosed: Do Not Open

PIN:

Town:

Name of Contractor:

October 16, 2001

STATE OF MAINE DEPARTMENT OF TRANSPORTATION
Bid Guaranty-Bid Bond Form

KNOW ALL MEN BY THESE PRESENTS THAT _____

_____, of the City/Town of _____ and State of _____

as Principal, and _____ as Surety, a

Corporation duly organized under the laws of the State of _____ and having a usual place of

Business in _____ and hereby held and firmly bound unto the Treasurer of

the State of Maine in the sum of _____ for payment which Principal and Surety bind

themselves, their heirs, executors, administrators, successors and assigns, jointly and severally.

The condition of this obligation is that the Principal has submitted to the Maine Department of

Transportation, hereafter Department, a certain bid, attached hereto and incorporated as a

part herein, to enter into a written contract for the construction of _____

_____ and if the Department shall accept said bid

and the Principal shall execute and deliver a contract in the form attached hereto (properly

completed in accordance with said bid) and shall furnish bonds for this faithful performance of

said contract, and for the payment of all persons performing labor or furnishing material in

connection therewith, and shall in all other respects perform the agreement created by the

acceptance of said bid, then this obligation shall be null and void; otherwise it shall remain in full

force, and effect.

Signed and sealed this _____ day of _____ 20_____

WITNESS:

WITNESS

PRINCIPAL:

By _____

By: _____

By: _____

SURETY:

By _____

By: _____

Name of Local Agency: _____

NOTICE

Bidders:

Please use the attached “Request for Information” form when submitting questions concerning specific Contracts that have been advertised for Bid, include additional numbered pages as required. RFI’s may be faxed to 207-624-3431, submitted electronically through the Departments web page of advertised projects by selecting the RFI tab on the project details page or via e-mail to RFI-Contracts.MDOT@maine.gov.

These are the only allowable mechanisms for answering Project specific questions. Maine DOT will not be bound to any answers to Project specific questions received during the Bidding phase through other processes.

When submitting RFIs by Email please follow the same guidelines as stated on the “Request for Information” form and include the word “RFI” along with the Project name and Identification number in the subject line.

Vendor Registration

Prospective Bidders must register as a vendor with the Department of Administrative & Financial Services if the vendor is awarded a contract. Vendors will not be able to receive payment without first being registered. Vendors/Contractors will find information and register through the following link –

<http://www.maine.gov/purchases/venbid/index.shtml>

**STATE OF MAINE DEPARTMENT OF TRANSPORTATION
NOTICE TO CONTRACTORS**

Sealed Bids addressed to the Maine Department of Transportation, Augusta, Maine 04333 and endorsed on the wrapper "Bids for Pavement Milling, Hot Mix Asphalt Overlay, with Drainage and Safety Improvements in the City of Augusta." will be received from contractors at the Reception Desk, Maine DOT Building, Capitol Street, Augusta, Maine, until 11:00 o'clock A.M. (prevailing time) on June 6, 2018 and at that time and place publicly opened and read. Bids will be accepted from all bidders. The lowest responsive bidder must have completed, or successfully complete, a Highway Construction, Paving, or project specific prequalification to be considered for the award of this contract. **We now accept electronic bids for those bid packages posted on the bidx.com website. Electronic bids do not have to be accompanied by paper bids. Please note: The Department will accept a facsimile of the bid bond; however, the original bid bond must then be received at the MDOT Contract Section within 72 hours of the bid opening.** Until further notice, dual bids (one paper, one electronic) will be accepted, with the paper copy taking precedence.

Description: 023444.40, WIN 23444.40.

Location: In Kennebec County, project is located on Interstate 95 Southbound, EXIT 109B Off Ramp, EXIT 109A Off Ramp, and EXIT 109 On Ramp in Augusta.

Outline of Work: Pavement Milling, Hot Mix Asphalt Overlay, with Drainage and Safety Improvements and other incidental work.

For general information regarding Bidding and Contracting procedures, contact George Macdougall at (207) 624-3410. Our webpage at <http://www.maine.gov/mdot/contractors/> contains a copy of the Schedule of Items, Plan Holders List, written portions of bid amendments, drawings, bid results and an electronic form for RFI submittal. For Project-specific information fax all questions to **Scott Bickford** at (207) 624-3431, use electronic RFI form or email questions to RFI-Contracts.MDOT@maine.gov, project name and identification number should be in the subject line. Questions received after 12:00 noon of Monday (or if that Monday is a state holiday, Friday) prior to bid date will not be answered. Bidders shall not contact any other Departmental staff for clarification of Contract provisions, and the Department will not be responsible for any interpretations so obtained. TTY users call Maine Relay 711.

Specifications and bid forms may be seen at the MaineDOT Building in Augusta, Maine. They may be purchased from the Department between the hours of 8:00 a.m. to 4:30 p.m. by cash, credit card (Visa/Mastercard) or check payable to Treasurer, State of Maine sent to Maine Department of Transportation, Attn.: Mailroom, 16 State House Station, Augusta, Maine 04333-0016. They also may be purchased by telephone at (207) 624-3536 between the hours of 8:00 a.m. to 4:30 p.m. Bid Book \$10 (\$13 by mail), payment in advance, all non-refundable.

Each Bid must be made upon blank forms provided by the Department and must be accompanied by a bid bond at 5% of the bid amount or an official bank check, cashier's check, certified check, certificate of deposit, or United States postal money order in the amount of **\$20,000** payable to Treasurer, State of Maine as a Bid guarantee. A Contract Performance Surety Bond and a Contract Payment Surety Bond, each in the amount of 100 percent of the Contract price, will be required of the successful Bidder.

This Contract is subject to all applicable State Laws.

All work shall be governed by "*State of Maine, Department of Transportation, Standard Specifications, November 2014 Edition,*" price \$10 [\$15 by mail], and *Standard Details, November 2014 Edition,* price \$10 [\$15 by mail]. They also may be purchased by telephone at (207) 624-3536 between the hours of 8:00 a.m. to 4:30 p.m. Standard Detail updates can be found at <http://www.maine.gov/mdot/contractors/publications/>.

The right is hereby reserved to the MaineDOT to reject any or all bids.

Augusta, Maine
May 23, 2018

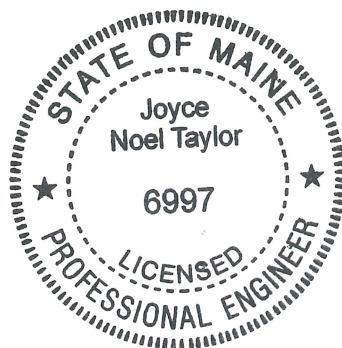

JOYCE NOEL TAYLOR P. E.
CHIEF ENGINEER

**SPECIAL PROVISION 102.7.3
ACKNOWLEDGMENT OF BID AMENDMENTS**

With this form, the Bidder acknowledges its responsibility to check for all Amendments to the Bid Package. For each Project under Advertisement, Amendments are located at <http://www.maine.gov/mdot/contractors/> . It is the responsibility of the Bidder to determine if there are Amendments to the Project, to download them, to incorporate them into their Bid Package, and to reference the Amendment number and the date on the form below. The Maine DOT will not post Bid Amendments any later than noon the day before Bid opening without individually notifying all the planholders.

Amendment Number	Date

The Contractor, for itself, its successors and assigns, hereby acknowledges that it has received all of the above referenced Amendments to the Bid Package.

CONTRACTOR

Date

Signature of authorized representative

(Name and Title Printed)

Maine Department of Transportation

Proposal Schedule of Items

Proposal ID: 023444.40

Project(s): 023444.40

SECTION: 1 HIGHWAY ITEMS

Alt Set ID: Alt Mbr ID:

Contractor: _____

Proposal Line Number	Item ID Description	Approximate Quantity and Units	Unit Price		Bid Amount	
			Dollars	Cents	Dollars	Cents
0010	202.20 REMOVING BITUMINOUS CONCRETE PAVEMENT	1,000.000 SY	_____	 _____	_____	 _____
0020	202.202 REMOVING PAVEMENT SURFACE	3,000.000 SY	_____	 _____	_____	 _____
0030	203.24 COMMON BORROW	500.000 CY	_____	 _____	_____	 _____
0040	403.2081 12.5 MM POLYMER MODIFIED HOT MIX ASPHALT	1,500.000 T	_____	 _____	_____	 _____
0050	403.211 HOT MIX ASPHALT (SHIMMING)	500.000 T	_____	 _____	_____	 _____
0060	403.2131 12.5 MM POLYMER MODIFIED HMA BASE	400.000 T	_____	 _____	_____	 _____
0070	409.15 BITUMINOUS TACK COAT - APPLIED	1,000.000 G	_____	 _____	_____	 _____
0080	603.155 12 INCH REINFORCED CONCRETE PIPE CLASS III	32.000 LF	_____	 _____	_____	 _____
0090	603.55 CONCRETE PIPE TIES	5.000 GP	_____	 _____	_____	 _____
0100	603.7424 REMOVE & RELAY 24 INCH CONCRETE PIPE	8.000 LF	_____	 _____	_____	 _____
0110	606.1301 31" W-BM GR, MID-WAY SPLICE-SGL FACED	350.000 LF	_____	 _____	_____	 _____

Maine Department of Transportation

Proposal Schedule of Items

Proposal ID: 023444.40

Project(s): 023444.40

SECTION: 1 HIGHWAY ITEMS

Alt Set ID: Alt Mbr ID:

Contractor: _____

Proposal Line Number	Item ID Description	Approximate Quantity and Units	Unit Price		Bid Amount	
			Dollars	Cents	Dollars	Cents
0120	606.1305 31" W-BM GR, MID-WAY SPLICE FLARED TERMINAL	2.000 EA	_____	 _____	_____	 _____
0130	606.265 TERMINAL END - SINGLE RAIL - GALVANIZED STEEL	1.000 EA	_____	 _____	_____	 _____
0140	606.353 REFLECTORIZED FLEXIBLE GUARDRAIL MARKER	3.000 EA	_____	 _____	_____	 _____
0150	618.14 SEEDING METHOD NUMBER 2	100.000 UN	_____	 _____	_____	 _____
0160	619.12 MULCH	100.000 UN	_____	 _____	_____	 _____
0170	627.18 12 " SOLID WHITE PAVEMENT MARKING	2,600.000 LF	_____	 _____	_____	 _____
0180	627.744 6" WHITE OR YELLOW PAINTED PAVEMENT MARKING LINE	7,500.000 LF	_____	 _____	_____	 _____
0190	627.781 TEMPORARY 6 INCH PAINTED PAVEMENT MARKING LINE, WHITE OR YELLOW	15,000.000 LF	_____	 _____	_____	 _____
0200	627.941 PREFORMED THERMOPLASTIC PAVEMENT MARKING	24.500 SF	_____	 _____	_____	 _____
0210	629.05 HAND LABOR, STRAIGHT TIME	20.000 HR	_____	 _____	_____	 _____
0220	631.12 ALL PURPOSE EXCAVATOR (INCLUDING OPERATOR)	20.000 HR	_____	 _____	_____	 _____

Maine Department of Transportation

Proposal Schedule of Items

Proposal ID: 023444.40

Project(s): 023444.40

SECTION: 1 HIGHWAY ITEMS

Alt Set ID: Alt Mbr ID:

Contractor: _____

Proposal Line Number	Item ID Description	Approximate Quantity and Units	Unit Price		Bid Amount	
			Dollars	Cents	Dollars	Cents
0230	631.172 TRUCK - LARGE (INCLUDING OPERATOR)	40.000 HR	_____	 _____	_____	 _____
0240	631.32 CULVERT CLEANER (INCLUDING OPERATOR)	10.000 HR	_____	 _____	_____	 _____
0250	645.1061 RELOCATE EXISTING SIGN ASSEMBLY AND POST	2.000 EA	_____	 _____	_____	 _____
0260	645.109 REMOVE AND SALVAGE HIGHWAY SIGNS	2.000 EA	_____	 _____	_____	 _____
0270	645.292 REGULATORY, WARNING, CONFIRMATION AND ROUTE MARKER ASSEMBLY SIGNS TYPE II	17.500 SF	_____	 _____	_____	 _____
0280	645.306 FLEXIBLE REFLECTORIZED DELINEATOR	20.000 EA	_____	 _____	_____	 _____
0290	652.30 FLASHING ARROW BOARD	3.000 EA	_____	 _____	_____	 _____
0300	652.312 TYPE III BARRICADE	9.000 EA	_____	 _____	_____	 _____
0310	652.33 DRUM	50.000 EA	_____	 _____	_____	 _____
0320	652.34 CONE	300.000 EA	_____	 _____	_____	 _____
0330	652.35 CONSTRUCTION SIGNS	1,300.000 SF	_____	 _____	_____	 _____

Maine Department of Transportation

Proposal Schedule of Items

Proposal ID: 023444.40

Project(s): 023444.40

SECTION: 1 HIGHWAY ITEMS

Alt Set ID: Alt Mbr ID:

Contractor: _____

Proposal Line Number	Item ID Description	Approximate Quantity and Units	Unit Price		Bid Amount	
			Dollars	Cents	Dollars	Cents
0340	652.36 MAINTENANCE OF TRAFFIC CONTROL DEVICES	20.000 CD	_____	 _____	_____	 _____
0350	652.41 PORTABLE CHANGEABLE MESSAGE SIGN	4.000 EA	_____	 _____	_____	 _____
0360	652.45 AUTOMATED TRAILER MOUNTED SPEED LIMIT SIGN	1.000 EA	_____	 _____	_____	 _____
0370	652.46 SEQUENTIAL FLASHING WARNING LIGHTS	10.000 EA	_____	 _____	_____	 _____
0380	652.47 TEMPORARY PORTABLE RUMBLE STRIP	2.000 GP	_____	 _____	_____	 _____
0390	656.75 TEMPORARY SOIL EROSION AND WATER POLLUTION CONTROL	LUMP SUM		LUMP SUM	_____	 _____
0400	659.10 MOBILIZATION	LUMP SUM		LUMP SUM	_____	 _____
Section: 1			Total:		_____	 _____
			Total Bid:		_____	 _____

CONTRACT AGREEMENT, OFFER & AWARD

AGREEMENT made on the date last signed below, by and between the State of Maine, acting through and by its Department of Transportation (Department), an agency of state government with its principal administrative offices located at Child Street, Augusta, Maine, with a mailing address at 16 State House Station, Augusta, Maine 04333-0016, and _____ a corporation or other legal entity organized under the laws of the State of _____, with its principal place of business located at _____

The Department and the Contractor, in consideration of the mutual promises set forth in this Agreement (the "Contract"), hereby agree as follows:

A. The Work.

The Contractor agrees to complete all Work as specified or indicated in the Contract including Extra Work in conformity with the Contract, **WIN 23444.40 for the Pavement Milling, Hot Mix Asphalt Overlay, with Drainage and Safety Improvements in the City of Augusta, County of Kennebec, Maine.** The Work includes construction, maintenance during construction, warranty as provided in the Contract, and other incidental work.

The Contractor shall be responsible for furnishing all supervision, labor, equipment, tools supplies, permanent materials and temporary materials required to perform the Work including construction quality control including inspection, testing and documentation, all required documentation at the conclusion of the project, warranting its work and performing all other work indicated in the Contract.

The Department shall have the right to alter the nature and extent of the Work as provided in the Contract; payment to be made as provided in the same.

B. Time.

The Contractor agrees to complete all Work, except warranty work, on or before **July 28, 2018.** Further, the Department may deduct from moneys otherwise due the Contractor, not as a penalty, but as Liquidated Damages in accordance with Sections 107.7 and 107.8 of the *State of Maine Department of Transportation Standard Specifications, November 2014 Edition* and related Special Provisions.

C. Price.

The quantities given in the Schedule of Items of the Bid Package will be used as the basis for determining the original Contract amount and for determining the amounts of the required Performance Surety Bond and Payment Surety Bond, and that the amount of this offer is _____

\$_____ Performance Bond and Payment Bond each being 100% of the amount of this Contract.

D. Contract.

This Contract, which may be amended, modified, or supplemented in writing only, consists of the Contract documents as defined in the Plans, *Standard Specifications, November 2014 Edition, Standard Details November 2014 Edition* as updated through advertisement, Supplemental Specifications, Special Provisions, Contract Agreement; and Contract Bonds. It is agreed and understood that this Contract will be governed by the documents listed above.

E. Certifications.

By signing below, the Contractor hereby certifies that to the best of the Contractor's knowledge and belief:

1. All of the statements, representations, covenants, and/or certifications required or set forth in the Bid and the Bid Documents, including those in the Contract are still complete and accurate as of the date of this Agreement.
2. The Contractor knows of no legal, contractual, or financial impediment to entering into this Contract.
3. The person signing below is legally authorized by the Contractor to sign this Contract on behalf of the Contractor and to legally bind the Contractor to the terms of the Contract.

F. Offer.

The undersigned, having carefully examined the site of work, the Plans, *Standard Specifications November 2014 Edition*, *Standard Details November 2014 Edition* as updated through advertisement, Supplemental Specifications, Special Provisions, Contract Agreement; and Contract Bonds contained herein for construction of: **WIN 23444.40 for the Pavement Milling, Hot Mix Asphalt Overlay, with Drainage and Safety Improvements in the City of Augusta, County of Kennebec**, State of Maine, on which bids will be received until the time specified in the “Notice to Contractors” do(es) hereby bid and offer to enter into this contract to supply all the materials, tools, equipment and labor to construct the whole of the Work in strict accordance with the terms and conditions of this Contract at the unit prices in the attached “Schedule of Items”.

The Offeror agrees to perform the work required at the price specified above and in accordance with the bids provided in the attached “Schedule of Items” in strict accordance with the terms of this solicitation, and to provide the appropriate insurance and bonds if this offer is accepted by the Government in writing.

As Offeror also agrees:

First: To do any extra work, not covered by the attached “Schedule of Items”, which may be ordered by the Resident, and to accept as full compensation the amount determined upon a “Force Account” basis as provided in the Standard Specifications, November 2014 Edition, and as addressed in the contract documents.

Second: That the bid bond at 5% of the bid amount or the official bank check, cashier’s check, certificate of deposit or U. S. Postal Money Order in the amount given in the “Notice to Contractors”, payable to the Treasurer of the State of Maine and accompanying this bid, shall be forfeited, as liquidated damages, if in case this bid is accepted, and the undersigned shall fail to abide by the terms and conditions of the offer and fail to furnish satisfactory insurance and Contract bonds under the conditions stipulated in the Specifications within 15 days of notice of intent to award the contract.

Third: To begin the Work as stated in Section 107.2 of the *Standard Specifications November 2014 Edition* and complete the Work within the time limits given in the Special Provisions of this Contract.

Fourth: That this offer shall remain open for 30 calendar days after the date of opening of bids.

Fifth: The Bidder hereby certifies, to the best of its knowledge and belief that: the Bidder has not, either directly or indirectly, entered into any agreement, participated in any collusion, or otherwise taken any action in restraint of competitive bidding in connection with its bid, and its subsequent contract with the Department.

IN WITNESS WHEREOF, the Contractor, for itself, its successors and assigns, hereby execute two duplicate originals of this Agreement and thereby binds itself to all covenants, terms, and obligations contained in the Contract Documents.

CONTRACTOR

Date

(Signature of Legally Authorized Representative
of the Contractor)

Witness

(Name and Title Printed)

G. Award.

Your offer is hereby accepted.
documents referenced herein.

This award consummates the Contract, and the

MAINE DEPARTMENT OF TRANSPORTATION

Date

By: David Bernhardt, Commissioner

Witness

CONTRACT AGREEMENT, OFFER & AWARD

AGREEMENT made on the date last signed below, by and between the State of Maine, acting through and by its Department of Transportation (Department), an agency of state government with its principal administrative offices located at Child Street, Augusta, Maine, with a mailing address at 16 State House Station, Augusta, Maine 04333-0016, and _____ a corporation or other legal entity organized under the laws of the State of _____, with its principal place of business located at _____

The Department and the Contractor, in consideration of the mutual promises set forth in this Agreement (the "Contract"), hereby agree as follows:

A. The Work.

The Contractor agrees to complete all Work as specified or indicated in the Contract including Extra Work in conformity with the Contract, **WIN 23444.40 for the Pavement Milling, Hot Mix Asphalt Overlay, with Drainage and Safety Improvements in the City of Augusta, County of Kennebec, Maine.** The Work includes construction, maintenance during construction, warranty as provided in the Contract, and other incidental work.

The Contractor shall be responsible for furnishing all supervision, labor, equipment, tools supplies, permanent materials and temporary materials required to perform the Work including construction quality control including inspection, testing and documentation, all required documentation at the conclusion of the project, warranting its work and performing all other work indicated in the Contract.

The Department shall have the right to alter the nature and extent of the Work as provided in the Contract; payment to be made as provided in the same.

B. Time.

The Contractor agrees to complete all Work, except warranty work, on or before **July 28, 2018.** Further, the Department may deduct from moneys otherwise due the Contractor, not as a penalty, but as Liquidated Damages in accordance with Sections 107.7 and 107.8 of the *State of Maine Department of Transportation Standard Specifications, November 2014 Edition* and related Special Provisions.

C. Price.

The quantities given in the Schedule of Items of the Bid Package will be used as the basis for determining the original Contract amount and for determining the amounts of the required Performance Surety Bond and Payment Surety Bond, and that the amount of this offer is _____

\$_____ Performance Bond and Payment Bond each being 100% of the amount of this Contract.

D. Contract.

This Contract, which may be amended, modified, or supplemented in writing only, consists of the Contract documents as defined in the Plans, *Standard Specifications, November 2014 Edition, Standard Details November 2014 Edition* as updated through advertisement, Supplemental Specifications, Special Provisions, Contract Agreement; and Contract Bonds. It is agreed and understood that this Contract will be governed by the documents listed above.

E. Certifications.

By signing below, the Contractor hereby certifies that to the best of the Contractor's knowledge and belief:

1. All of the statements, representations, covenants, and/or certifications required or set forth in the Bid and the Bid Documents, including those in the Contract are still complete and accurate as of the date of this Agreement.
2. The Contractor knows of no legal, contractual, or financial impediment to entering into this Contract.
3. The person signing below is legally authorized by the Contractor to sign this Contract on behalf of the Contractor and to legally bind the Contractor to the terms of the Contract.

F. Offer.

The undersigned, having carefully examined the site of work, the Plans, *Standard Specifications November 2014 Edition*, *Standard Details November 2014 Edition* as updated through advertisement, Supplemental Specifications, Special Provisions, Contract Agreement; and Contract Bonds contained herein for construction of: **WIN 23444.40 for the Pavement Milling, Hot Mix Asphalt Overlay, with Drainage and Safety Improvements in the City of Augusta, County of Kennebec**, State of Maine, on which bids will be received until the time specified in the “Notice to Contractors” do(es) hereby bid and offer to enter into this contract to supply all the materials, tools, equipment and labor to construct the whole of the Work in strict accordance with the terms and conditions of this Contract at the unit prices in the attached “Schedule of Items”.

The Offeror agrees to perform the work required at the price specified above and in accordance with the bids provided in the attached “Schedule of Items” in strict accordance with the terms of this solicitation, and to provide the appropriate insurance and bonds if this offer is accepted by the Government in writing.

As Offeror also agrees:

First: To do any extra work, not covered by the attached “Schedule of Items”, which may be ordered by the Resident, and to accept as full compensation the amount determined upon a “Force Account” basis as provided in the Standard Specifications, November 2014 Edition, and as addressed in the contract documents.

Second: That the bid bond at 5% of the bid amount or the official bank check, cashier’s check, certificate of deposit or U. S. Postal Money Order in the amount given in the “Notice to Contractors”, payable to the Treasurer of the State of Maine and accompanying this bid, shall be forfeited, as liquidated damages, if in case this bid is accepted, and the undersigned shall fail to abide by the terms and conditions of the offer and fail to furnish satisfactory insurance and Contract bonds under the conditions stipulated in the Specifications within 15 days of notice of intent to award the contract.

Third: To begin the Work as stated in Section 107.2 of the *Standard Specifications November 2014 Edition* and complete the Work within the time limits given in the Special Provisions of this Contract.

Fourth: That this offer shall remain open for 30 calendar days after the date of opening of bids.

Fifth: The Bidder hereby certifies, to the best of its knowledge and belief that: the Bidder has not, either directly or indirectly, entered into any agreement, participated in any collusion, or otherwise taken any action in restraint of competitive bidding in connection with its bid, and its subsequent contract with the Department.

IN WITNESS WHEREOF, the Contractor, for itself, its successors and assigns, hereby execute two duplicate originals of this Agreement and thereby binds itself to all covenants, terms, and obligations contained in the Contract Documents.

CONTRACTOR

Date

(Signature of Legally Authorized Representative
of the Contractor)

Witness

(Name and Title Printed)

G. Award.

Your offer is hereby accepted.
documents referenced herein.

This award consummates the Contract, and the

MAINE DEPARTMENT OF TRANSPORTATION

Date

By: David Bernhardt, Commissioner

Witness

CONTRACT AGREEMENT, OFFER & AWARD

AGREEMENT made on the date last signed below, by and between the State of Maine, acting through and by its Department of Transportation (Department), an agency of state government with its principal administrative offices located at Child Street Augusta, Maine, with a mailing address at 16 State House Station, Augusta, Maine 04333-0016, and
(Name of the firm bidding the job)
a corporation or other legal entity organized under the laws of the State of Maine, with its principal place of business located at (address of the firm bidding the job)

The Department and the Contractor, in consideration of the mutual promises set forth in this Agreement (the "Contract"), hereby agree as follows:

A. The Work.

The Contractor agrees to complete all Work as specified or indicated in the Contract including Extra Work in conformity with the Contract, PIN No. **1224.00**, for the **Hot Mix Asphalt Overlay** in the town/city of **South Nowhere**, County of **Washington**, Maine. The Work includes construction, maintenance during construction, warranty as provided in the Contract, and other incidental work.

The Contractor shall be responsible for furnishing all supervision, labor, equipment, tools supplies, permanent materials and temporary materials required to perform the Work including construction quality control including inspection, testing and documentation, all required documentation at the conclusion of the project, warranting its work and performing all other work indicated in the Contract.

The Department shall have the right to alter the nature and extent of the Work as provided in the Contract; payment to be made as provided in the same.

B. Time.

The Contractor agrees to complete all Work, except warranty work, on or before **November 15, 2006**. Further, the Department may deduct from moneys otherwise due the Contractor, not as a penalty, but as Liquidated Damages in accordance with Sections 107.7 and 107.8 of the State of Maine Department of Transportation Standard Specifications, Revision of December 2002 and related Special Provisions.

C. Price.

The quantities given in the Schedule of Items of the Bid Package will be used as the basis for determining the original Contract amount and for determining the amounts of the required Performance Surety Bond and Payment Surety Bond, and that the amount of this offer is (Place bid here in alphabetical form such as One Hundred and Two dollars and 10 cents)
\$ (repeat bid here in numerical terms, such as \$102.10) Performance Bond and Payment Bond each being 100% of the amount of this Contract.

D. Contract.

This Contract, which may be amended, modified, or supplemented in writing only, consists of the Contract documents as defined in the Plans, Standard Specifications, Revision of December 2002, Standard Details Revision of December 2002, Supplemental Specifications, Special Provisions, Contract Agreement; and Contract Bonds. It is agreed and understood that this Contract will be governed by the documents listed above.

E. Certifications.

By signing below, the Contractor hereby certifies that to the best of the Contractor's knowledge and belief:

1. All of the statements, representations, covenants, and/or certifications required or set forth in the Bid and the Bid Documents, including those in Appendix A to Division 100 of the Standard Specifications Revision of December 2002 (Federal Contract Provisions Supplement), and the Contract are still complete and accurate as of the date of this Agreement.
2. The Contractor knows of no legal, contractual, or financial impediment to entering into this Contract.
3. The person signing below is legally authorized by the Contractor to sign this Contract on behalf of the Contractor and to legally bind the Contractor to the terms of the Contract.

F. Offer.

The undersigned, having carefully examined the site of work, the Plans, Standard Specifications, Revision of December 2002, Standard Details Revision of December 2002, Supplemental Specifications, Special Provisions, Contract Agreement; and Contract Bonds contained herein for construction of:

PIN 1234.00 South Nowhere, Hot Mix Asphalt Overlay

State of Maine, on which bids will be received until the time specified in the "Notice to Contractors" do(es) hereby bid and offer to enter into this contract to supply all the materials, tools, equipment and labor to construct the whole of the Work in strict accordance with the terms and conditions of this Contract at the unit prices in the attached "Schedule of Items".

The Offeror agrees to perform the work required at the price specified above and in accordance with the bids provided in the attached "Schedule of Items" in strict accordance with the terms of this solicitation, and to provide the appropriate insurance and bonds if this offer is accepted by the Government in writing.

As Offeror also agrees:

First: To do any extra work, not covered by the attached "Schedule of Items", which may be ordered by the Resident, and to accept as full compensation the amount determined upon a "Force Account" basis as provided in the Standard Specifications, Revision of December 2002, and as addressed in the contract documents.

Second: That the bid bond at 5% of the bid amount or the official bank check, cashier's check, certificate of deposit or U. S. Postal Money Order in the amount given in the "Notice to Contractors", payable to the Treasurer of the State of Maine and accompanying this bid, shall be forfeited, as liquidated damages, if in case this bid is accepted, and the undersigned shall fail to abide by the terms and conditions of the offer and fail to furnish satisfactory insurance and Contract bonds under the conditions stipulated in the Specifications within 15 days of notice of intent to award the contract.

Third: To begin the Work as stated in Section 107.2 of the Standard Specifications Revision of 2002 and complete the Work within the time limits given in the Special Provisions of this Contract.

Fourth: The Contractor will be bound to the Disadvantaged Business Enterprise (DBE) Requirements contained in the attached Notice (Additional Instructions to Bidders) and submit a completed Contractor's Disadvantaged Business Enterprise Utilization Plan with their bid.

Fifth: That this offer shall remain open for 30 calendar days after the date of opening of bids.

Sixth: The Bidder hereby certifies, to the best of its knowledge and belief that: the Bidder has not, either directly or indirectly, entered into any agreement, participated in any collusion, or otherwise taken any action in restraint of competitive bidding in connection with its bid, and its subsequent contract with the Department.

IN WITNESS WHEREOF, the Contractor, for itself, its successors and assigns, hereby execute two duplicate originals of this Agreement and thereby binds itself to all covenants, terms, and obligations contained in the Contract Documents.

Date

(Witness Sign Here)
Witness

(Sign Here)
(Signature of Legally Authorized Representative of the Contractor)

(Print Name Here)
(Name and Title Printed)

CONTRACTOR

G. Award.

Your offer is hereby accepted.

This award consummates the Contract, and the documents referenced herein.

MAINE DEPARTMENT OF TRANSPORTATION

Date

By: David Bernhardt, Commissioner

(Witness)

BOND

CONTRACT PERFORMANCE BOND
(Surety Company Form)

KNOW ALL MEN BY THESE PRESENTS: That _____
_____ **in the State of** _____, as principal,
and _____,
a corporation duly organized under the laws of the State of _____ and having a
usual place of business _____,
as Surety, are held and firmly bound unto the Treasurer of the State of Maine in the sum
of _____ **and 00/100 Dollars (\$** _____ **)**,
to be paid said Treasurer of the State of Maine or his successors in office, for which
payment well and truly to be made, Principal and Surety bind themselves, their heirs,
executors and administrators, successors and assigns, jointly and severally by these
presents.

The condition of this obligation is such that if the Principal designated as Contractor in
the Contract to construct Project Number _____ in the Municipality of
_____ promptly and faithfully performs the Contract, then this
obligation shall be null and void; otherwise it shall remain in full force and effect.

The Surety hereby waives notice of any alteration or extension of time made by the State
of Maine.

Signed and sealed this _____ day of _____, 20_____

WITNESSES: SIGNATURES:

CONTRACTOR:

Signature.....

Print Name Legibly

SURETY:

Signature

Print Name Legibly

SURETY ADDRESS:

.....

.....

.....

TELEPHONE.....

BOND # _____

CONTRACT PAYMENT BOND
(Surety Company Form)

KNOW ALL MEN BY THESE PRESENTS: That _____
_____ **in the State of** _____, as principal,
and.....

a corporation duly organized under the laws of the State of and having a
usual place of business in
as Surety, are held and firmly bound unto the Treasurer of the State of Maine for the use
and benefit of claimants as herein below defined, in the sum of
_____ **and 00/100 Dollars (\$** _____ **)**
for the payment whereof Principal and Surety bind themselves, their heirs, executors and
administrators, successors and assigns, jointly and severally by these presents.

The condition of this obligation is such that if the Principal designated as Contractor in
the Contract to construct Project Number _____ in the Municipality of
_____ promptly satisfies all claims and demands incurred for all
labor and material, used or required by him in connection with the work contemplated by
said Contract, and fully reimburses the obligee for all outlay and expense which the
obligee may incur in making good any default of said Principal, then this obligation shall
be null and void; otherwise it shall remain in full force and effect.

A claimant is defined as one having a direct contract with the Principal or with a
Subcontractor of the Principal for labor, material or both, used or reasonably required for
use in the performance of the contract.

Signed and sealed this day of, 20 .. .

WITNESS: SIGNATURES:

CONTRACTOR:

Signature.....

Print Name Legibly

SURETY:

Signature.....

Print Name Legibly

SURETY ADDRESS:

NAME OF LOCAL AGENCY:

..... ADDRESS

TELEPHONE

NOTICE TO CONTRACTORS - PREFERRED EMPLOYEES

Sec. 1303. Public Works; minimum wage

In the employment of laborers in the construction of public works, including state highways, by the State or by persons contracting for the construction, preference must first be given to citizens of the State who are qualified to perform the work to which the employment relates and, if they can not be obtained in sufficient numbers, then to citizens of the United States. Every contract for public works construction must contain a provision for employing citizens of this State or the United States. The hourly wage and benefit rate paid to laborers employed in the construction of public works, including state highways, may not be less than the fair minimum rate as determined in accordance with section 1308. Any contractor who knowingly and willfully violates this section is subject to a fine of not less than \$250 per employee violation. Each day that any contractor employs a laborer at less than the wage and benefit minimum stipulated in this section constitutes a separate violation of this section. [1997, c. 757, §1 (amd).]

STATE OF MAINE
DEPARTMENT OF TRANSPORTATION



AUGUSTA

KENNEBEC COUNTY

INTERSTATE 95 SOUTHBOUND EXIT 109 A&B

STATE PROJECT 023444.40

PROJECT LENGTH : 0.86 MILES

DATE: 5/18/18	APPROVED: [Signature]	COMMISSIONER: [Signature]	CHIEF ENGINEER: [Signature]
PROJECT INFORMATION	PROGRAM: HIGHWAY	PROJECT NUMBER: 023444.40	PROJECT NAME: INTERSTATE 95 "F" RAMP
PROJECT MANAGER: SHAWN SMITH	PROJECT NUMBER: 023444.40	CONTRACTOR: [Blank]	PROJECT COMPLETION DATE: [Blank]
SIGNATURE: [Signature]	DATE: 4-23-18	PROJECT INFORMATION	PROJECT INFORMATION

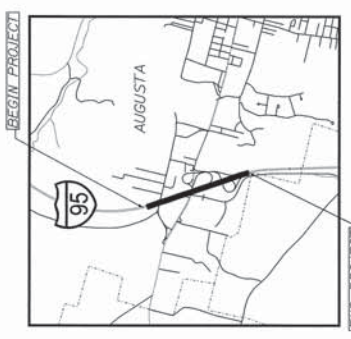
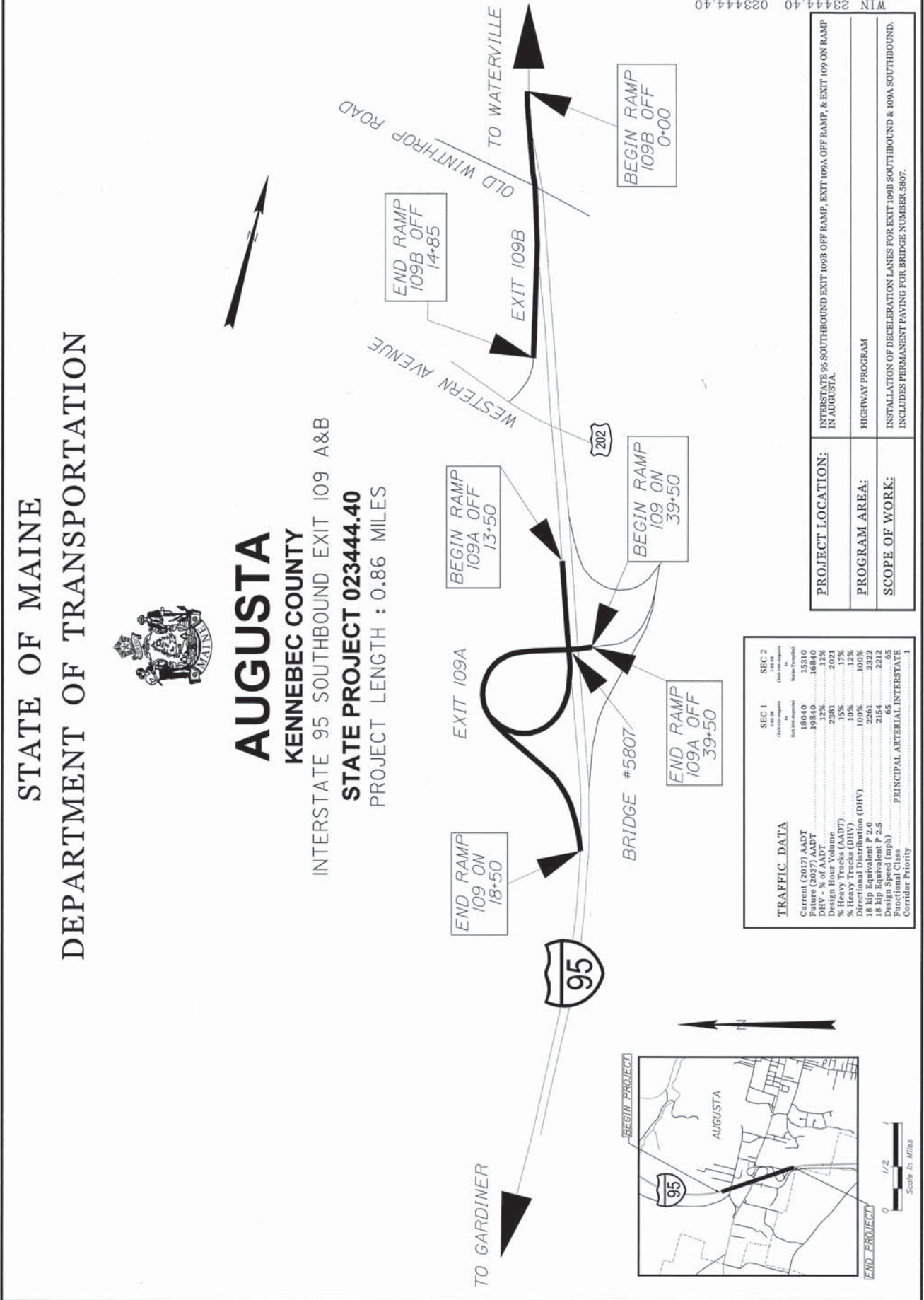

TRAFFIC DATA	SEC 1	SEC 2
	18+50	0+00
Current (2017) AADT	18040	15310
Future (2037) AADT	19840	16840
DHV - % of AADT	12%	12%
Design Hour Volume (DHV)	2381	2021
% Heavy Trucks (DHV)	10%	12%
Directional Distribution (DHV)	100%	100%
18 kip Equivalent P 2.0	2261	2322
18 kip Equivalent P 2.5	2154	2312
Design Speed (mph)	65	65
Corridor Priority	PRINCIPAL ARTERIAL, INTERSTATE	

PROJECT LOCATION:	INTERSTATE 95 SOUTHBOUND EXIT 109B OFF RAMP, EXIT 109A OFF RAMP, & EXIT 109 ON RAMP IN AUGUSTA.
PROGRAM AREA:	HIGHWAY PROGRAM
SCOPE OF WORK:	INSTALLATION OF DECELERATION LANES FOR EXIT 109B SOUTHBOUND & 109A SOUTHBOUND. INCLUDES PERMANENT PAVING FOR BRIDGE NUMBER 5807.

WIN 23444.40 023444.40

TITLE SHEET
AUGUSTA
INTERSTATE 95 "F" RAMP
SHEET NUMBER
1
OF 1

EXIT 109A ON/OFF
 SHIM & OVERLAY
 FULL WIDTH

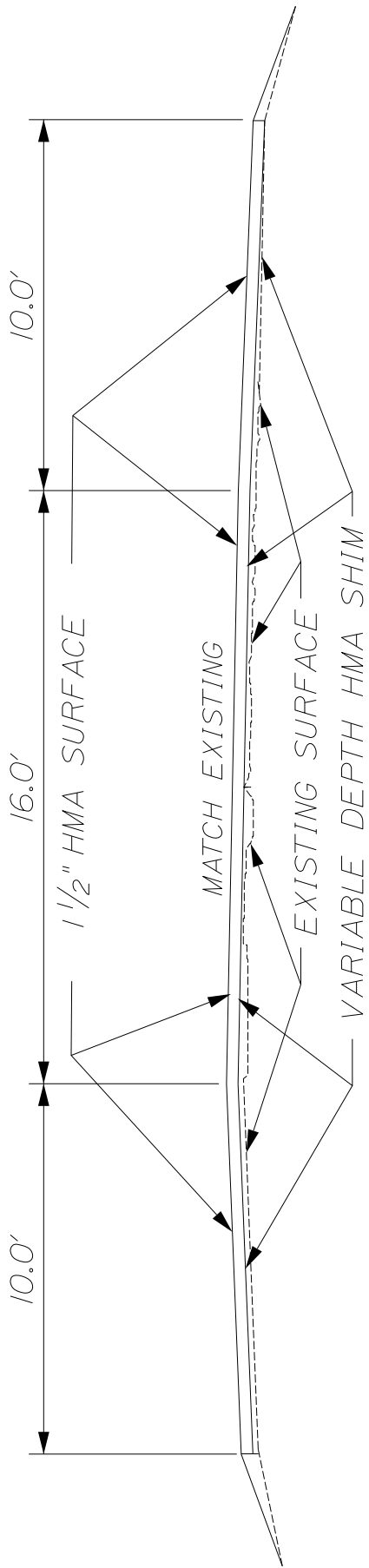

NOT TO SCALE

RAMP STATIONING

Exit 109B Off Ramp

STA. 0+00 = Begin Construction

STA. 14+85 = End Construction at joint

Exit 109A Off Ramp

STA. 13+50 = Begin Construction

STA. 39+50 = End Construction

STA. 35+71 = Bridge Joint

STA. 37+86 = Bridge Joint

Exit 109 On On Ramp

STA. 39+50 = Begin Construction

STA. 18+50 = End Construction at joint

STA. 37+86 = Bridge Joint

STA. 35+71 = Bridge Joint

Construction Notes

All spoils, HMA & millings shall be cleaned daily from project to the satisfaction of the Resident prior to the contractor leaving for the shift.

Reference to left or right is in the direction of stationing which runs south to north.

Item 202.20 Removing Bituminous Concrete Pavement

Milling widths & depths may be adjusted by the Resident.

Exit 109 On/Off Ramp Bridge Approaches

<u>Station</u>	<u>to</u>	<u>Station</u>	<u>Depth</u>	<u>Remarks</u>
34+67	-	35+71	10'+/-	Remove Existing Pavement full width
37+86	-	38+77	10'+/-	Remove Existing Pavement full width

Item 202.202 Removing Pavement Surface

Exit 109B Off Ramp

<u>Station</u>	<u>to</u>	<u>Station</u>	<u>SY</u>	<u>Depth</u>	<u>Remarks</u>
0+00		7+00+/-	1020+/-	1 1/2"	mill full width Shoulder

Exit 109A Off Ramp

<u>Station</u>	<u>to</u>	<u>Station</u>	<u>SY</u>	<u>Depth</u>	<u>Remarks</u>
21+50		23+50+/-	800+/-	1 1/2"	mill full width Shoulder

Exit 109 On/Off Ramp (East Side)

<u>Station</u>	<u>to</u>	<u>Station</u>	<u>SY</u>	<u>Depth</u>	<u>Remarks</u>
18+50		20+50+/-	550+/-	1 1/2"	mill full width
38+77		39+50+/-	400+/-	1 1/2"	mill full width Inbound/Outbound

Construction Notes

Item 202.202 Removing Pavement Surface (Continued)

The Contractor will retain 100% of the millings/grindings. The Payment for delivery and stockpiling will be incidental to Item 202.202. Stockpiling shall include all equipment, personnel, and all other necessary incidentals required to construct stockpiles as per normal construction practices.

Item 203.24 Common Borrow

Item to be used to fill slope Exit 109A Off Ramp Station 38+00-39+66 Right.

Item 629.05 Hand Labor, Straight Time

This item to be used for cleaning culverts, cleaning winter sand from guardrail areas and paved areas under overpasses, installation of protective sleeves for guardrail near gas line at Old Winthrop Road Overpass, and other tasks as directed.

631 Items

These items estimated for removing excess material from in-slopes, in-slopes behind guardrail areas, ditching, and other work as directed. All equipment used for certain operations will be as directed by the Resident. Cleaning of the pavement following rental work will be considered incidental to the rental items. Cleaning will be done daily and to the satisfaction of the Resident prior to the Contractor leaving the project for the shift.

GENERAL NOTES

1. All joints between existing and proposed hot mix asphalt shall be butted. Payment shall be made under Item 202.202.
2. Any damage to the slopes caused by the Contractor's equipment, personnel, or operation shall be repaired to the satisfaction of the Resident. All work, equipment and materials required to make repairs shall be at the Contractor's expense.
3. Any necessary cleaning of existing pavement prior to paving or milling shall be incidental to the related items.
4. As directed by the Resident, all existing Underdrain Outlets shall be located, cleaned out, and ditched as required or replaced as necessary. Payment will be made under appropriate hourly contract items.
5. Guardrail which is removed and not reused on the project shall become the property of the Contractor. Removal and disposal shall be considered incidental to the guardrail items.
6. Holes created by Guardrail removal will be filled and compacted with approved materials as directed by the Resident. Payment to be considered incidental to the guardrail items.
7. Connections for proposed guardrail to existing guardrail will be considered incidental to Item 606.
8. "Undetermined Locations" shall be determined by the Resident.
9. Stations referenced are approximate.
10. All work shall be done in accordance with the *Maine Department of Transportation's Best Management Practices for Erosion and Sedimentation Control, February, 2008*.
11. The paved gore areas between the on/off ramps and the mainline shall have an edge line of 12-inch white pavement marking line, Item 627.18, as directed by the Resident.
12. No separate payment for superintendent or foreman will be made for the supervision of work paid under equipment rental items, however supervision is required.
13. Existing culverts and catch basins will be cleaned as directed by the Resident under the appropriate Pay Items.

GENERAL NOTES

14. The following shall be incidental to the 603/604 item(s):
- Any cutting of existing culverts and or connectors necessary to install new culvert replacements or extensions
 - All pipe excavation including any cutting and removal of pavement
 - All ditching at pipe ends
 - Furnishing, placing, grading, and compacting of any new gravel and/or fill material. This also includes Granular Borrow used under pipes and for temporary detours to maintain traffic during pipe installation (excavation is also incidental).
 - Granular Borrow under the pipe shall meet the requirements for Underwater Backfill
 - All work necessary to connect to existing pipes
 - Flow lines may be changed by 1½ ft.
 - Any necessary clearing of brush and small trees at culvert ends
 - An 18” wide strip of non-woven geotextile meeting the requirements of Item 620.58 shall be placed over all pipe joints

SPECIAL PROVISIONS
SECTION 104
Utilities

GENERALNOTES

This is an emergency project. The utilities are aware of the emergency status and will carry out their work as quickly as possible. The utilities may already be on site when the contractor arrives. The contractor shall contact the utilities immediately after contract award to gauge utility progress and coordinate work zone activities.

UTILITY COORDINATION

The contractor has primary responsibility for coordinating their work with utilities after contract award. The contractor shall communicate directly with the utilities regarding any utility work necessary to maintain the contractor’s schedule and prevent project construction delays. The contractor shall notify the resident of any issues.

THE CONTRACTOR SHALL PLAN AND CONDUCT WORK ACCORDINGLY.

MEETING

A Preconstruction Utility Conference, as defined in Subsection 104.4.6 of the Standard Specifications **IS** required.

GENERAL INFORMATION

These Special Provisions outline the arrangements that have been made by the Department for utility and/or railroad work to be undertaken in conjunction with this project. The following list identifies all known utilities or railroads having facilities presently located within the limits of this project or intending to install facilities during project construction.

Utilities have been notified and will be furnished a copy of the specification.

Overview:

Utility/Railroad	Aeria I	Underground
Central Maine Power Company	X	
Charter Communications	X	
Fairpoint Communications - Northern New England Telephone Operations LLC	X	
Firstlight	X	
Greater Augusta Utility District		X
Maine Natural Gas		X

Town: **Augusta**
 Project: **23444.40**
 Date: **May 02, 2018**

Utility Contact Information		
Utility/Railroad	Contact Person	Contact Phone
Central Maine Power Company	Tim Robbins	(207)626-9443
Charter Communications	Dave Bouchard	(207)620-3411
Fairpoint Communications	Jim Scheid	(207)626-2031
Firstlight	Mike Ellingwood	(207)333-3471
Greater Augusta Utility District	Michael Morey	(207)622-3701
Maine Natural Gas	Roger Lockhart	(207)841-7391

Temporary Aerial utility adjustments are not anticipated on this project however, should the contractor choose to have any poles temporarily relocated, all work will be done by Pole owner at the contractor's request and expense at no additional cost to the Department.

Aerial Utility adjustments are anticipated at this time for the project.

Unless otherwise specified, any underground utility facilities shown on the project plans represent approximate locations gathered from available information. The Department cannot certify the level of accuracy of this data. Underground facilities indicated on the topographic sheets (plan views) have been collected from historical records and/or on-site designations provided by the respective utility companies.

All adjustments are to be made by the respective utility/railroad unless otherwise specified herein. Fire hydrants shall not be disturbed until all necessary work has been accomplished to provide proper fire protection.

**** Specific information regarding the line voltage can be requested from Central Maine Power Company****

Utility working days are Monday through Friday, conditions permitting. Times are estimated on the basis of a single crew for each utility.

The contractor shall give all Utilities **5 working days notice** prior to beginning any work on this project.

AERIAL

Utility Specific Issues:

Aerial Utility adjustments are not anticipated at this time for the project.

Utility Specific Issues:

SUBSURFACE

Utility	Summary of Work	Estimate of Working Days
Maine Natural Gas	Reinstalling a vent	3
Total:		3

Greater Augusta Utility District (GAUD) has a drinking water system located within the limits of the project. **GAUD** must be contacted immediately after contract award to have a person onsite while the contractor is digging near their facilities or to make any adjustments to them.

Maine Natural Gas has a pipe line within the project limits. As a result of this project **MNG** will be reinstalling a vent pipe that was removed last fall at the underpass of Old Winthrop Rd. on the West side of I-95 and estimates **3** working days to do the work. The contractor must coordinate with Maine Natural Gas in advance of excavation within the proximity of the main so they can provide on-site representative. **MNG** requires 5 working days advance notice prior to any operations involving work around their buried lines.

MAINTAINING UTILITY LOCATION MARKINGS

The contractor will be responsible for maintaining the buried utility location markings following the initial locating by the appropriate utility or their designated representative.

UTILITY SIGNING

Any utility working within the construction limits of this project shall ensure that the traveling public is adequately protected at all times. All work areas shall be signed, lighted, and traffic flaggers employed as determined by field conditions. All traffic controls shall be in accordance with the latest edition of the Manual on Uniform Traffic Control Devices for Streets and Highways, as issued by the Federal Highway Administration.

THIS DOCUMENT MUST BE CLEARLY POSTED AT THE PERTAINING STATE FUNDED PREVAILING WAGE CONSTRUCTION SITE

**State of Maine
Department of Labor
Bureau of Labor Standards
Augusta, Maine 04333-0045
Telephone (207) 623-7906**

Wage Determination - In accordance with 26 MRSA §1301 et. seq., this is a determination by the Bureau of Labor Standards, of the fair minimum wage rate to be paid to laborers and workers employed on the below titled project.

Title of Project -----23444.40-Interstate 95 Southbound Augusta Ramp F

Location of Project –Augusta, Kennebec County

**2018 Fair Minimum Wage Rates
Highway & Earth Kennebec County**

<u>Occupation Title</u>	<u>Minimum Wage</u>	<u>Minimum Benefit</u>	<u>Total</u>	<u>Occupation Title</u>	<u>Minimum Wage</u>	<u>Minimum Benefit</u>	<u>Total</u>
Asphalt Raker	\$17.63	\$0.56	\$18.19	Ironworker – Ornamental	\$23.13	\$4.80	\$27.93
Backhoe Loader Operator	\$20.00	\$2.23	\$22.23	Ironworker - Reinforcing	\$24.79	\$10.60	\$35.39
Boom Truck (Truck Crane) Operator	\$21.66	\$6.86	\$28.52	Ironworker - Structural	\$21.80	\$4.88	\$26.68
Bulldozer Operator	\$21.50	\$4.38	\$25.88	Laborer (Includes Helper-Tender)	\$14.50	\$0.95	\$15.45
Carpenter	\$21.00	\$2.36	\$23.36	Laborer - Skilled	\$17.00	\$2.48	\$19.48
Cement Mason/Finisher	\$17.00	\$0.56	\$17.56	Line Erector-Power/Cable Splicer	\$26.00	\$7.59	\$33.59
Crane Operator =>15 Tons)	\$26.00	\$5.97	\$31.97	Loader Operator - Front-End	\$19.00	\$2.88	\$21.88
Crusher Plant Operator	\$18.00	\$3.46	\$21.46	Mechanic- Maintenance	\$20.85	\$3.02	\$23.87
Diver	\$28.50	\$1.48	\$29.98	Painter	\$17.00	\$0.00	\$17.00
Driller -Rock	\$18.38	\$2.60	\$20.98	Paver Operator	\$19.13	\$4.42	\$23.55
Earth Auger Operator	\$22.97	\$6.17	\$29.14	Pipelayer	\$18.00	\$3.16	\$21.16
Electrician - Licensed	\$26.00	\$4.67	\$30.67	Pump Installer	\$21.00	\$3.73	\$24.73
Electrician Helper/Cable Puller (Licensed)	\$17.00	\$2.84	\$19.84	Reclaimer Operator	\$19.13	\$2.98	\$22.11
Elevator Constructor/Installer	\$19.25	\$1.62	\$20.87	Roller Operator - Earth	\$16.00	\$1.89	\$17.89
Excavator Operator	\$21.05	\$2.94	\$23.99	Roller Operator - Pavement	\$18.15	\$2.19	\$20.34
Fence Setter	\$17.25	\$1.72	\$18.97	Screed/Wheelman	\$18.60	\$3.68	\$22.28
Flagger	\$12.00	\$0.00	\$12.00	Truck Driver - Light	\$16.75	\$1.71	\$18.46
Grader/Scraper Operator	\$21.33	\$5.65	\$26.98	Truck Driver - Medium	\$17.75	\$1.99	\$19.74
Highway Worker/Guardrail Installer	\$16.50	\$0.79	\$17.29	Truck Driver - Heavy	\$16.00	\$1.71	\$17.71
Hot Top Plant Operator	\$23.88	\$5.62	\$29.50	Truck Driver - Tractor Trailer	\$18.50	\$2.60	\$21.10

The Laborer classifications include a wide range of work duties. Therefore, if any specific occupation to be employed on this project is not listed in this determination, call the Bureau of Labor Standards at the above number for further clarification.

Welders are classified in the trade to which the welding is incidental.

Apprentices - The minimum wage rate for registered apprentices are those set forth in the standards and policies of the Maine State Apprenticeship and Training Council for approved apprenticeship programs.

Posting of Schedule - Posting of this schedule is required in accordance with 26 MRSA §1301 et. seq., by any contractor holding a State contract for construction valued at \$50,000 or more and any subcontractors to such a contractor.

Appeal - Any person affected by the determination of these rates may appeal to the Commissioner of Labor by filing a written notice with the Commissioner stating the specific grounds of the objection within ten (10) days from the filing of these rates.

Determination No: HI-112-2018

A true copy

Filing Date: April 18, 2018

Attest: Scott A. Cotnoir

Expiration Date: 12-31-2018

**Scott A. Cotnoir
Wage & Hour Director**

BLS(Highway & Earth Kennebec)

SPECIAL PROVISION
SECTION 105
General Scope of Work
(Environmental Requirements)

Work within and adjacent to wetlands require special conditions to minimize impacts. The following special conditions apply to the project:

I. Work within wetlands applies to the following location:

1. Flattening of inslope to remove guardrail at GPS coordinates Lat: 44.312990 N,
Long: - 69.809085 W

II. Special Conditions:

1. Conditions of the U.S. Army Corps of Engineers Category 1 Permit Number NAE-2017-01028 shall apply to this project (see permit and conditions in the contract documents).

III. Approvals:

1. Temporary Soil Erosion and Water Pollution Control Plan
2. Permitted Protected Natural Resource Impacts, see U.S. Army Corps of Engineers Category 2 Permit Number NAE-2018-01028 for locations:
 - a. Wetland
 - i. Permanent: 3,200 s.f.
 - ii. Temporary: 4,000 s.f.

SPECIAL PROVISION
SECTION 105
GENERAL SCOPE OF WORK
(LIMITATIONS OF OPERATIONS)

1. Interstate Crossovers shall not be utilized to change direction.
2. Lane closure length will be kept to the minimum required for the shifts' operation, not to exceed 3.0 miles.
3. The contractor shall plan operations so that the Resident will have sufficient advance notification to provide the necessary inspection and testing. Sufficient notification will be considered 48 hours.
4. All pipe work, clearing, including slope repairs from clearing operations, and rental items shall be completed in an area prior to the contractor commencing placement of HMA surface in a given area unless authorized by the Department.
5. Traffic will be allowed to travel on milled surfaces on the mainline. After 7 calendar days any milled areas not covered, in need of extra repair or maintenance (please see Special Provision 202), shall be repaired to the satisfaction of the Resident. All work, equipment and materials required to make repairs shall be at the Contractor's expense. Failure to adequately maintain milled areas will also result in a violation of Special Provision 652. The Contractor shall plan and conduct their work accordingly.
6. Prior to the weekend, ALL milling and paving joints shall be relatively matched even unless specifically allowed in Special Provisions 202, 400, or 403.
7. Weepers shall be milled on the shoulder to allow for water run-off/drainage as directed by the Resident. These shall be able to be traversed in a manner non-detrimental to vehicles at posted speeds until paving operations are completed in that lane. This work shall be considered incidental to 652 items.

**SPECIAL PROVISION
SECTION 105
CONTROL OF WORK
(Cooperation Between Contractors)**

It is hereby brought to the Contractor's attention that the Department has awarded and plans to award contracts adjacent to the limits of this contract, which may be in progress simultaneously. MaineDOT Maintenance & Operations may have contractually obligated work, as well as routine maintenance activities being conducted within and in close proximity of the limits for this project.

The Contractor shall also coordinate this contract's projects with local municipalities' projects.

The Contractor shall cooperate with other Contractors at all times and provide project access as necessary and as directed by the Resident.

The Contractor will coordinate all activities including traffic control with others to ensure safe travel for motorists. This shall be specifically addressed within the Contractors Traffic Control Plan.

The Contractor shall coordinate their activities with surrounding municipalities and utilities as part of this Contract.

SPECIAL PROVISION
SECTION 107
PROSECUTION AND PROGRESS
(Contract Time)

The Contractor may begin work Anytime in accordance with Standard Specification 104.4.2 and upon approval of all required submittals. The Contract Completion Date will be no later than **July 28, 2018.**

At least 21 calendar days prior to the desired Begin Construction Date the Contractor shall submit an **electronic copy of their signed request to begin work and the Begin Construction Date.** This signed request shall be sent read receipt through email with their **Schedule of Work**, in accordance with Standard Specification 107.4.2, to Shawn.Smith@Maine.gov, Emory.Lovely@Maine.gov, and Scott.Bickford@Maine.gov. The Contractor shall notify all utility contacts listed in the 104 Special Provision and provide the utility contacts the submitted schedule of work within 2 calendar days of the schedule of work submittal. **A penalty in the amount of \$500/day will be assessed for each calendar day or partial calendar day beyond June 15th that the schedule of work is not received.** Upon receipt of the schedule of work, a pre-construction meeting will be scheduled. A Contract Modification will be executed to document the new Contract Completion Date based upon the Begin Construction Date. The modified Contract Completion Date shall not exceed the Contract Completion Date specified in this special provision.

The Contractor may request to adjust the submitted schedule of work and Begin Construction Date once after the initial submittal. The Department will allow adjustments in the Begin Construction Date of up to seven calendar days if the request is made at least 21 calendar days prior to the updated Begin Construction Date. This signed request shall be sent read receipt through email with their **Schedule of Work**, in accordance with Standard Specification 107.4.2, to Shawn.Smith@Maine.gov, Emory.Lovely@Maine.gov, and Scott.Bickford@Maine.gov. The Contractor shall notify all utility contacts listed in the 104 Special Provision and provide the utility contacts the updated schedule of work within 2 calendar days of the request to adjust the Begin Construction Date.

**SPECIAL PROVISION
SECTION 107
(Contract Time)**

1. Ramps may be closed Sunday night through Friday morning between the hours of 9 pm to 6 am with 72 hours' notice. Work on ramps may continue after these hours with shoulder closures only. The contractor shall notify local emergency personnel resources of closure dates and times. The Contractor shall be allowed to close the entire Augusta Mile 109A Southbound Off/On Interchange provided 72 hours written notice is given. Under no circumstances will Exit 109A and 109B Off Ramps be closed simultaneously. Message Boards will be in-place 72 hours prior to ramp closure with a message approved by the Department.
2. The Contractor is advised that no work shall be allowed on the following dates and times:
 - a. July 2 beginning at sunset to July 8 at 6 am.
3. Upon completion or any suspension of milling the Contractor shall begin paving operations no later than the following workday. For each working day that the contractor does not pave or mill the contractor will be charged Liquidated Damages at the rate stated in the Department's Standard Specifications section 107.7.2. (Excluding days lost to inclement weather). The Contractor shall plan and conduct their work accordingly.
4. The contractor shall only be allowed to enter the roadway during the following hours; Lane closure set and removal shall be considered to be part of this time:
 - a. Sunday beginning 7 pm ending Monday 7am.
 - b. Monday beginning 7pm ending Tuesday 7am.
 - c. Tuesday beginning 7pm ending Wednesday 7am.
 - d. Wednesday beginning 7pm ending Thursday 7am.
 - e. Thursday beginning 7pm ending Friday 7am.
 - f. Friday beginning 7pm ending Saturday 7am.
5. Any occurrence outside of these time frames, the Contractor shall be charged Supplemental Liquidated Damages as outlined in Special Provision 107 (Supplemental Liquidated Damages).

SPECIAL PROVISION
SECTION 107
CONTROL OF WORK
(Supplemental Liquidated Damages)

General: Monetary assessments will be made against the Contractor for each ¼ hour there are lane restrictions as specified below.

Definitions of Terms: For this contract the following definitions apply:

- (a) Calendar Day: Any portion of the day on the calendar including Saturdays, Sundays, and holidays, beginning and ending at midnight.
- (b) Hour: Any continuous 60 minute period or portion of a continuous 60 minute period beginning at the point when a lane and/or shoulder is closed or obstructed by the contractor's operation(s).
- (c) 15 Minute Period: Any portion of a 15 minute continuous period.
- (d) Obstruction: When the contractor's operation(s) have resulted in the useable lane width of the travel lane or passing lane to be less than that specified in the plan documents.

This contract includes a supplemental liquidated damage procedure under which the contractor is assessed a charge for each lane closure outside the time periods specified under Special Provision 105 Note 15. One lane must remain open at **ALL** times. The charge will be assessed for each lane restriction as follows:

One Lane Closed	\$1,000/ 0 - 15 Minutes
	\$2,000/ 16 -30 Minutes
	\$5,000/ 31-45 Minutes
	\$10,000/ 46-60 Minutes

*** These charges will be accumulative in nature. Example: 0 to 15 minutes, the contractor shall be assessed \$1,000.00. From 16 minutes to 30 minutes the charges will be \$2,000.00 + \$1,000.00 = \$3,000.00, and so on. Times above 60 minutes shall receive an additional assessment of \$15,000.00 for each portion of a 15 minute time period.**

The applicable charges will be deducted from any monies due the Contractor for work performed. The deduction will be based on the applicable rate for any and all closures whether work is being performed or not. Deductions will be accomplished through progress payments due the Contractor.

The Contractor shall address in their Traffic Control Plan a contingency plan for opening up both lanes of traffic within one hour of being notified by the Resident. This plan shall be fully detailed, and Permission to open up both lanes shall only be granted if work being performed can safely be stopped to allow lanes to be opened to traffic.

SPECIAL PROVISIONS
SECTION 202
REMOVING STRUCTURES AND OBSTRUCTIONS
(Removing Pavement Surface)

The November 2014 Revision of the Standard Specifications, Section 202-Removing Structures and Obstructions, subsection 202.061-Removing Pavement Surface, has been removed and replaced in its entirety by the following:

202.061 Removing Pavement Surface The equipment for removing the bituminous surface shall be a power operated milling machine or grinder capable of removing bituminous concrete pavement to the required depth, transverse cross slope, and profile grade by the use of an automated grade and slope control system. The controls shall automatically increase or decrease the pavement removal depth as required, and readily maintain desired cross slope, to compensate for surface irregularities in the existing pavement course. The equipment shall be capable of accurately establishing profile grades by referencing from a fixed reference such as a grade wire, or from the existing pavement surface using a 30 foot minimum contact ski (floating beam), or 24 foot non-contact grade control beam.

The Contractor shall locate and remove all objects in the pavement through the work area that would be detrimental to the planing or grinding machine. Any structures or obstructions left within the travel lane or shoulders shall have tapers installed according to Standard Detail 202(01). The finished milled surface will be inspected before being accepted, and any deviations in the profile exceeding 1/2 inch under a 16 foot string line or straightedge placed parallel to the centerline will be corrected. Any deviations in the cross-slope that exceed 3/8 inch under a 10 foot string line or straightedge placed transversely to centerline will be corrected. All corrections will be made with approved methods and materials. Any areas that require corrective measures will be subject to the same acceptance tolerances. Excess material that becomes bonded to the milled surface will be removed to the Resident's satisfaction before the area is accepted.

On highways or expressways with directional traffic, the Contractor will be required to remove the pavement surface on the adjacent sections of travel lane and designated portions of adjacent shoulder before the end of the following calendar day unless the centerline edge is tapered to a 12:1. Failure to remove the centerline vertical edge by milling, using the approved taper, or matching the adjacent course the following day will constitute a traffic control violation unless an excusable delay is granted by the Department. The Contractor will be required to remove the specified pavement course over the full width of the mainline traveled ways prior to opening the sections to weekend or holiday traffic.

On roadways with two-way traffic, the Contractor will be required to remove the specified pavement course over the full width of the mainline traveled ways prior to opening the sections to weekend or holiday traffic.

During any period that a centerline vertical or tapered edge exists, the Contractor will be responsible for installing additional warning signage that clearly defines the centerline vertical or tapered edge and elevation differential hazard, as well as additional centerline delineation such as double RPM application, or temporary painted line. The Traffic Control Plan shall include the additional requirements. All signs and traffic control devices will conform to Section 719.01, and Section 652, and will be installed prior to the work, at a maximum spacing of 0.50 mile for the entire length of the effected roadway section. All additional signing, labor, traffic control devices, or incidentals will not be paid for directly, but will be considered incidental to the appropriate 652 bid items.

When pavement milling operations leave a 2 inch or less exposed vertical face at the edge of the traveled way, RPMs shall be placed on the remaining pavement surface along the vertical edge at 200 foot intervals. Uneven pavement signs shall be placed at a maximum spacing of ½ mile when pavement milling operations leave an exposed vertical face at the edge of travelway.

When pavement milling operations on directional or bi-directional traffic roadways leave an exposed vertical face greater than 2 inches at the edge of the traveled way the edge shall be either;

1. Be tapered to a zero edge by means of milling a 12:1 transition from the edge of traveled way onto the shoulder before opening the lane to traffic. Tapers shall be removed to form a vertical edge prior to the placement of the new pavement course. No additional payment will be made for tapers, or taper removal.
2. Have an additional 2 feet of pavement shall be removed from the shoulder to eliminate the vertical edge at the edge of travelway before opening the lane to traffic. Payment will be made under the pavement removal item.
3. A pavement layer will be placed to reduce the vertical edge to 2 inch or less before opening the lane to traffic.

As a minimum, the use of temporary painted line, or RPMs placed along the edge of traveled way at 200 foot intervals is required. When pavement milling is extended into the shoulder (including milled tapers), appropriate channelization devices shall be placed 2 feet outside the edge of the vertical face at intervals not exceeding 600 feet, and RPMs shall be placed on the remaining pavement surface along the vertical edge at 200 foot intervals. Uneven pavement signs shall be placed at a maximum spacing of ½ mile when any pavement milling operations leaves an exposed uneven pavement surface.

Any areas of concern, such as de-lamination or pot-holing shall be identified on a continuous basis as milling progresses. Proper corrective action will be determined by the Resident and paid for under the appropriate contract items, and if required, completed prior to opening lane to traffic. Any issues that arise **up to** 7 calendar days after being milled will be the responsibility of the MaineDOT unless otherwise noted in Special Provision Section 105 – Limitations Of Operations. Issues that arise after 7 calendar days will be the responsibility of the Contractor unless otherwise noted in Special Provision Section 105 – Limitations Of Operations.

MAINE TURNPIKE AUTHORITY

WORK PERMIT RULES AND GUIDELINES

Prior to any work or installation of any facility on **Maine Turnpike Authority** land, a **Municipality, Contractor, or other Person requesting access (Permittee)** is required to file application with the **Authority** for a work permit. Said permit will be issued under the following terms and conditions;

Permittee indemnifies and holds harmless the **Maine Turnpike Authority** from any and all responsibility related to work on the aforesaid property or the presence thereon of **Permittee's** employees and agents. This includes, but is not limited to, any claims, losses damages and expenses (including attorney's fees and litigation costs) that arise from or are related to the presence of **Permittee's** employees or agents on the property. Nothing contained herein is intended to waive the defenses and immunities available to the **Authority** with respect to third parties under the provisions of State or Federal Law including, but not limited to, the defenses and immunities provided under the Maine Tort Claims Act.

Insurance

Prior to any entrance onto the **Authority's** land, **Permittee** will file with the **Authority** certificates of insurance evidencing public liability insurance and workers compensation insurance with such limits as the **Authority** shall require, which in all cases shall be a minimum of one million dollars (\$1,000,000), and the "**Maine Turnpike Authority**" shall be named as an additional insured.

Permittee shall maintain the insurance required by this paragraph with the **Authority** named as an additional insured, for so long as **Permittee's** employees or agents will be accessing **Authority** property whether the access is for construction or for routine maintenance and operation of this or any other installation.

Schedule

Permittee shall notify the **Authority** in advance of its work schedule. The **Authority** must approve of the schedule, including traffic control plan, and may decide to have an Inspector present while the work is being completed. Time of day restrictions may be enforced based on time of year and peak travel flow.

Costs

The **Permittee** shall be responsible for all costs incurred by the **Authority** acting in connection with the review, assessment, and negotiation of, and any necessary investigation into, any matters associated with this permit, including, but not limited to costs of reviewing any materials or documents submitted; any field work done in connection therewith, any dig safe, engineering, survey, personnel costs, or legal fees associated therewith, whether or not the project is ever carried to a successful conclusion. Prepayment of costs may be required at **Authority's** discretion.



Safety

The **Permittee** must abide by all applicable local, state, and federal regulations pertaining to workplace safety, including but not limited to high visibility clothing, signage, and warning lights. Median openings and toll plaza U-turns will not be permitted. Any traffic stoppages will be done with the **Authority's** approval and with State Police participation.

Revocation

The **Authority** further reserves the right to revoke the work permit in the event of a breach of its conditions as well as for any reason whatsoever that, in the sole judgment of the **Authority**, warrants such a revocation.

Contact

The **Permittee** shall make application to the **Authority** in writing. Said application will include, but is not limited to applicable plan sheets showing scope of work, traffic control plans, schedule, and insurance certificate. Applications may be submitted to:

Maine Turnpike Authority
Right of Way Department
2360 Congress Street
Portland, ME 04102

For questions or additional information contact the Right of Way Department at (207) 871-7771 Ext. 370 or 350
row@maineturnpike.com

At such time a work permit is issued by the Right of Way Department, the **Permittee** will be directed to the appropriate contact person for the duration of the project.

Dig Safe requests will be made to **Dig Safe** (1-888-DIG-SAFE or 811) and to **DigSmart of Maine** for private utility identification. Proof of utility location must be received prior to the issuance of any work permit that involves earthwork. The dig safe job number is to be provided to:

John Roberts
jroberts@maineturnpike.com
or
Scott Lachance
slachance@maineturnpike.com

DigSmart of Maine
114 Sawyer Road
Scarborough, ME 04074
(207) 749-7231
www.digsmartofmaine.com

Maine Turnpike Authority
2360 Congress Street
Portland, ME 04102
(207) 871-7771

On the Website, go to the *Schedule Work* button to complete DigSmart's electronic request form



MAINE TURNPIKE AUTHORITY

WORK PERMIT

The **Maine Turnpike Authority** grants permission to XXXXXXXXXXXXXXXX (Permittee) to enter upon the property of the Maine Turnpike Authority in XXXXXXXXXXXX, Maine as shown on Plans titled "XXXXXXXXXXXXXXXXXXXX" Sheets XX for the purpose of:

XX

Subject to a document titled "Maine Turnpike Authority - Work Permit Rules and Guidelines" and the following conditions:

- 1) **Permittee** indemnifies and holds harmless the **Maine Turnpike Authority** from any and all responsibility related to work on the aforesaid property or the presence thereon of **Permittee's** employees and agents. This includes, but is not limited to, any claims, losses damages and expenses (including attorney's fees and litigation costs) that arise from or are related to the presence of **Permittee's** employees or agents on the property. Nothing contained herein is intended to waive the defenses and immunities available to the **Maine Turnpike Authority** with respect to third parties under the provisions of State or Federal Law including, but not limited to, the defenses and immunities provided under the Maine Tort Claims Act.
- 2) Prior to any entrance onto the Authority's land, **Permittee** will file with the **Maine Turnpike Authority** certificates of insurance evidencing public liability insurance and workers compensation insurance with such limits as the **Maine Turnpike Authority** shall require, which in all cases shall be a minimum of one million (\$1,000,000) dollars, and the **Maine Turnpike Authority** shall be named as an additional insured.

Permittee shall maintain the insurance required by this paragraph with the Authority named as an additional insured, for so long as **Permittee's** employees or agents will be accessing Authority property whether the access is for construction or for routine maintenance and operation of this or any other installation.

- 3) **Permittee** shall notify the Authority in advance of its work schedule. The Authority must approve of the schedule and may decide to be present while the work is being completed. The **Permittee** acknowledges and agrees that the **Permittee** shall be responsible for all costs incurred by the **Maine Turnpike Authority** acting in connection with the review, assessment, and negotiation of, and any necessary investigation into, any matters associated with this permit, including, but not limited to costs of reviewing any materials or documents submitted; any field work done in connection therewith, and any engineering, dig safe, survey, or legal fees associated therewith, whether or not the project is ever carried to a successful conclusion.
- 4) The **Permittee** must abide by all applicable local, state, and federal regulations pertaining to workplace safety, including but not limited to high visibility clothing, signage, and warning lights. Median openings shall not be used.
- 5) The **Maine Turnpike Authority** further reserves the right to revoke this permit in the event of a breach of its conditions as well as for any reason whatsoever that, in the sole judgment of the **Authority**, warrants such a revocation.

Signed;

Stephen R. Tartre, PE
Maine Turnpike Authority

Date

XXXXXXXXXX
XXXXXXXXXXXXXXXXXXXX

Date

Maine Turnpike Authority
Date: January 26, 2011

The following Special Provision pertains to entry onto the Maine Turnpike Authority land by Contractors of the Maine Department of Transportation.

110.3.8 Administrative & General Provisions

A. Additional Insured

The Maine Turnpike Authority shall be named as an additional insured.

105.5.1 General Requirements

Subsection is amended by the addition of the following:

Prior to any work or installation of any facility on Maine Turnpike Authority land, a Contractor (Permittee) working for the Maine Department of Transportation is required to file application with the Authority for a Work Permit. Contractor must abide by the Maine Turnpike Authority agreement with the Maine Department of Transportation regarding Entry onto Maine Turnpike Authority Land by Contractors of the Maine Department of Transportation. All specific operational, safety, and environmental requirements of the Authority for a contractor will be followed.

The installation of construction signs on the Maine Turnpike shall be approved in advance by the Maine Turnpike Authority. The Contractor shall submit plans illustrating construction details and proposed locations. Signs shall be located behind guardrail or outside of the roadside recovery area or shall be installed on break away supports. The Contractor must contact the Maine Turnpike Authority Dig Safe vender to perform Dig Safe for Maine Turnpike Authority owned utilities on Maine Turnpike Authority property. The cost of this service is borne by the contractor.

This Subsection is amended by the addition of the following:

Change of Direction

The Contractor will not be allowed to use the median openings or the toll plaza on the Maine Turnpike to reverse direction unless the opening is located within a passing lane closures on both roadways.

The Contractor will not be allowed to change direction within the Toll Plaza area. The limits of this area extend from the terminals of the median guardrail north and south of the toll plaza.

The Contractor will be assessed a fine every time any employee of the Contractor, Subcontractor or Supplier is observed using a median opening or toll plaza area to change

Maine Turnpike Authority
Date: January 26, 2011

direction on the Maine Turnpike. (The fine will be deducted from monies owed to the Contractor.)

The fines will be levied on a per occurrence basis as follows:

NUMBER OF Occurrences	Fine
First	\$150

For the second occurrence, and any occurrence thereafter, the fine is increased by \$150 per each occurrence. The number of occurrences is not specific to a Contract, an individual or a vehicle, but based solely on the number of times any employee of the Contractor, Subcontractor or Supplier is observed using a median opening anywhere on the Maine Turnpike.

107.4.2 Schedule of Work Required

This Subsection is amended by the addition of the following:

The Contractor shall submit a schedule that shows all work on the Maine Turnpike that is anticipated for the following week. This schedule shall be transmitted to the Resident Engineer by noon Thursday of the preceding week. The Resident Engineer shall transmit this information to the Maine Turnpike Authority. Any lane or shoulder closures are subject to approval by the Maine Turnpike Authority.

The Contractor shall submit a schedule that shows all work within 1500' of the toll plaza and all toll plaza lane closures that are anticipated for the following week. This schedule shall be transmitted to the Resident Engineer by noon Thursday of the preceding week. The Resident Engineer shall transmit this information to the Maine Turnpike Authority.

The following Subsections are added:

107.4.6 Prosecution of Work

The installation of permanent signs on the Maine Turnpike will require a shoulder closure in accordance with the MUTCD (Manual of Uniform Traffic Control Devices).

Maine Turnpike Authority

Date: January 26, 2011

All work within 1500' of the toll plaza shall be coordinated with the Maine Turnpike Authority. Night work may be required to accommodate Turnpike operations. This work is required to be shown on the proposed schedule as noted in Section 107.4.2. The Engineer shall be responsible for coordinating the activities with the Maine Turnpike on site toll supervisor or his designee immediately prior to the operations. Restrictions in contractor operations may be required by the Maine Turnpike Authority.

652 Maintenance of Traffic

Subsection is amended by the addition of the following:

A mounted revolving Amber light or amber strobe light with 360-degree visibility.

The following Special Provision pertains to entry onto the Maine Turnpike Authority land by Contractors of the Maine Department of Transportation.

110.3.8 Administrative & General Provisions

A. Additional Insured

The Maine Turnpike Authority shall be named as an additional insured.

105.5.1 General Requirements

Subsection is amended by the addition of the following:

Prior to any work or installation of any facility on Maine Turnpike Authority land, a Contractor (Permittee) working for the Maine Department of Transportation is required to file application with the Authority for a Work Permit. Contractor must abide by the Maine Turnpike Authority agreement with the Maine Department of Transportation regarding Entry onto Maine Turnpike Authority Land by Contractors of the Maine Department of Transportation. All specific operational, safety, and environmental requirements of the Authority for a contractor will be followed.

The installation of construction signs on the Maine Turnpike shall be approved in advance by the Maine Turnpike Authority. The Contractor shall submit plans illustrating construction details and proposed locations. Signs shall be located behind guardrail or outside of the roadside recovery area or shall be installed on break away supports. The Contractor must contact the Maine Turnpike Authority Dig Safe vender to perform Dig Safe for Maine Turnpike Authority owned utilities on Maine Turnpike Authority property. The cost of this service is borne by the contractor.

This Subsection is amended by the addition of the following:

Change of Direction

The Contractor will not be allowed to use the median openings or the toll plaza on the Maine Turnpike to reverse direction unless the opening is located within a passing lane closures on both roadways.

The Contractor will not be allowed to change direction within the Toll Plaza area. The limits of this area extend from the terminals of the median guardrail north and south of the toll plaza.

The Contractor will be assessed a fine every time any employee of the Contractor, Subcontractor or Supplier is observed using a median opening or toll plaza area to change direction on the Maine Turnpike. (The fine will be deducted from monies owed to the Contractor.)

The fines will be levied on a per occurrence basis as follows:

NUMBER OF Occurrences	Fine
First	\$150

For the second occurrence, and any occurrence thereafter, the fine is increased by \$150 per each occurrence. The number of occurrences is not specific to a Contract, an individual, or a vehicle, but based solely on the number of times any employee of the Contractor, Subcontractor, or Supplier is observed using a median opening anywhere on the Maine Turnpike.

107.4.2 Schedule of Work Required

This Subsection is amended by the addition of the following:

The Contractor shall submit a schedule that shows all work on the Maine Turnpike that is anticipated for the following week. This schedule shall be transmitted to the Resident Engineer by noon Thursday of the preceding week. The Resident Engineer shall transmit this information to the Maine Turnpike Authority. Any lane or shoulder closures are subject to approval by the Maine Turnpike Authority.

The Contractor shall submit a schedule that shows all work within 1500' of the toll plaza and all toll plaza lane closures that are anticipated for the following week. This schedule shall be transmitted to the Resident Engineer by noon Thursday of the preceding week. The Resident Engineer shall transmit this information to the Maine Turnpike Authority.

The following Subsections are added:

107.4.6 Prosecution of Work

The installation of permanent signs on the Maine Turnpike will require a shoulder closure in accordance with the MUTCD (Manual of Uniform Traffic Control Devices).

All work within 1500' of the toll plaza shall be coordinated with the Maine Turnpike Authority. Night work may be required to accommodate Turnpike operations. This work is required to be shown on the proposed schedule as noted in Section 107.4.2. The Engineer shall be responsible for coordinating the activities with the Maine Turnpike on site toll supervisor or his designee immediately prior to the operations. Restrictions in contractor operations may be required by the Maine Turnpike Authority.

652 Maintenance of Traffic

This Subsection is amended by the addition of the following:

A mounted revolving Amber light or amber strobe light with 360-degree visibility.

SPECIAL PROVISIONS
SECTION 202
REMOVING STRUCTURES AND OBSTRUCTIONS
(Removing Pavement Surface)

The November 2014 Revision of the Standard Specifications, Section 202-Removing Structures and Obstructions, subsection 202.061-Removing Pavement Surface, has been removed and replaced in its entirety by the following:

202.061 Removing Pavement Surface The equipment for removing the bituminous surface shall be a power operated milling machine or grinder capable of removing bituminous concrete pavement to the required depth, transverse cross slope, and profile grade by the use of an automated grade and slope control system. The controls shall automatically increase or decrease the pavement removal depth as required, and readily maintain desired cross slope, to compensate for surface irregularities in the existing pavement course. The equipment shall be capable of accurately establishing profile grades by referencing from a fixed reference such as a grade wire, or from the existing pavement surface using a 30 foot minimum contact ski (floating beam), or 24 foot non-contact grade control beam.

The Contractor shall locate and remove all objects in the pavement through the work area that would be detrimental to the planing or grinding machine. Any structures or obstructions left within the travel lane or shoulders shall have tapers installed according to Standard Detail 202(01). The finished milled surface will be inspected before being accepted, and any deviations in the profile exceeding 1/2 inch under a 16 foot string line or straightedge placed parallel to the centerline will be corrected. Any deviations in the cross-slope that exceed 3/8 inch under a 10 foot string line or straightedge placed transversely to centerline will be corrected. All corrections will be made with approved methods and materials. Any areas that require corrective measures will be subject to the same acceptance tolerances. Excess material that becomes bonded to the milled surface will be removed to the Resident's satisfaction before the area is accepted.

On highways or expressways with directional traffic, the Contractor will be required to remove the pavement surface on the adjacent sections of travel lane and designated portions of adjacent shoulder before the end of the following calendar day unless the centerline edge is tapered to a 12:1. Failure to remove the centerline vertical edge by milling, using the approved taper, or matching the adjacent course the following day will constitute a traffic control violation unless an excusable delay is granted by the Department. The Contractor will be required to remove the specified pavement course over the full width of the mainline traveled ways prior to opening the sections to weekend or holiday traffic.

On roadways with two-way traffic, the Contractor will be required to remove the specified pavement course over the full width of the mainline traveled ways prior to opening the sections to weekend or holiday traffic.

During any period that a centerline vertical or tapered edge exists, the Contractor will be responsible for installing additional warning signage that clearly defines the centerline vertical or tapered edge and elevation differential hazard, as well as additional centerline delineation such as double RPM application, or temporary painted line. The Traffic Control Plan shall include the additional requirements. All signs and traffic control devices will conform to Section 719.01, and Section 652, and will be installed prior to the work, at a maximum spacing of 0.50 mile for the entire length of the effected roadway section. All additional signing, labor, traffic control devices, or incidentals will not be paid for directly, but will be considered incidental to the appropriate 652 bid items.

When pavement milling operations leave a 2 inch or less exposed vertical face at the edge of the traveled way, RPMs shall be placed on the remaining pavement surface along the vertical edge at 200 foot intervals. Uneven pavement signs shall be placed at a maximum spacing of ½ mile when pavement milling operations leave an exposed vertical face at the edge of travelway.

When pavement milling operations on directional or bi-directional traffic roadways leave an exposed vertical face greater than 2 inches at the edge of the traveled way the edge shall be either;

1. Be tapered to a zero edge by means of milling a 12:1 transition from the edge of traveled way onto the shoulder before opening the lane to traffic. Tapers shall be removed to form a vertical edge prior to the placement of the new pavement course. No additional payment will be made for tapers, or taper removal.
2. Have an additional 2 feet of pavement shall be removed from the shoulder to eliminate the vertical edge at the edge of travelway before opening the lane to traffic. Payment will be made under the pavement removal item.
3. A pavement layer will be placed to reduce the vertical edge to 2 inch or less before opening the lane to traffic.

As a minimum, the use of temporary painted line, or RPMs placed along the edge of traveled way at 200 foot intervals is required. When pavement milling is extended into the shoulder (including milled tapers), appropriate channelization devices shall be placed 2 feet outside the edge of the vertical face at intervals not exceeding 600 feet, and RPMs shall be placed on the remaining pavement surface along the vertical edge at 200 foot intervals. Uneven pavement signs shall be placed at a maximum spacing of ½ mile when any pavement milling operations leaves an exposed uneven pavement surface.

Any areas of concern, such as de-lamination or pot-holing shall be identified on a continuous basis as milling progresses. Proper corrective action will be determined by the Resident and paid for under the appropriate contract items, and if required, completed prior to opening lane to traffic. Any issues that arise **up to** 7 calendar days after being milled will be the responsibility of the MaineDOT unless otherwise noted in Special Provision Section 105 – Limitations Of Operations. Issues that arise after 7 calendar days will be the responsibility of the Contractor unless otherwise noted in Special Provision Section 105 – Limitations Of Operations.

SPECIAL PROVISION
SECTION 401 - HOT MIX ASPHALT PAVEMENT

The Standard Specification 401 – Hot Mix Asphalt Pavement, has been modified with the following revisions. All sections not revised by this Supplemental Specification shall be as outlined in Section 401 of the Standard Specifications.

401.07 Hot Mix Asphalt Plant

401.071 General Requirements HMA plants shall conform to AASHTO M156-97.

a. Truck Scales When the hot mix asphalt is to be weighed on scales meeting the requirements of Section 108 - Payment, the scales shall be inspected and sealed by the State Sealer as often as the Department deems necessary to verify their accuracy.

Plant scales shall be checked prior to the start of the paving season, and each time a plant is moved to a new location. Subsequent checks will be made as determined by the Resident. The Contractor will have at least ten 50 pound masses for scale testing.

b. Additives Additives (WMA, anti-strip, etc.) not directly introduced into the binder at the terminal shall be introduced into the HMA plant per the supplier's recommendations and shall be approved by the Asphalt Pavement Engineer, Pavement Quality Manager, or their authorized representative. The system for introducing additives shall be interlocked with the aggregate feed or weigh system to maintain correct proportions for all rates of production and batch sizes. Additive introduction systems shall be controlled by a proportioning device to the amount required on the JMF plus or minus 0.1% of the target. Additive introduction systems shall be interlocked with the plant and the recordation (batch tickets or drum recordation) shall display the additive and the weight and percentage added.

c. Stockpiles HMA plants shall have sufficient space for stockpiles, with a minimum of supply for 2 days production of all aggregate products used in MaineDOT approved mix designs currently under production for the facility at all times. A minimum stockpile supply of 100 ton (70 yards) shall be maintained at all times no matter the production rate for the HMA plant. Stockpiles shall be separated and built to minimize segregation.

401.18 Quality Control Method A, B & C The Contractor shall operate in accordance with the approved Quality Control Plan (QCP) to assure a product meeting the contract requirements. The QCP shall meet the requirements of Section 106.6 - Acceptance and this Section. The Contractor shall not begin paving operations until the Department approves the QCP in writing.

The QCP shall address any items that affect the quality of the Hot Mix Asphalt Pavement including, but not limited to, the following:

- a. JMF(s)
- b. Hot mix asphalt plant details
- c. Stockpile Management (to include provisions for how the requirements of 401.071c will be met)
- d. Make and type of paver(s)
- e. Make and type of rollers including weight, weight per inch of steel wheels, and average contact pressure for pneumatic tired rollers
- f. Name of QCP Administrator, and certification number
- g. Name of Process Control Technician(s) and certification number(s)
- h. Name of Quality Control Technicians(s) and certification number(s)
- i. Mixing & transportation including process for ensuring that truck bodies are clean and free of debris or contamination that could adversely affect the finished pavement
- j. Testing Plan
- k. Laydown operations including longitudinal joint construction, procedures for avoiding paving in inclement weather, type of release agent to be used on trucks tools and rollers, compaction of shoulders, tacking of all joints, methods to ensure that segregation is minimized, procedures to determine the maximum rolling and paving speeds based on best engineering practices as well as past experience in achieving the best possible smoothness of the pavement. Solvent based agents developed to strip asphalts from aggregates will not be allowed as release agents.
- l. Examples of Quality Control forms including a daily plant report, daily paving report, and delivery slip template for any plant to be utilized.
- m. Silo management and details (can show storage for use on project of up to 36 hours)
- n. Provisions for varying mix temperature due to extraordinary conditions or production limitations. If a warm-mix technology is utilized, a proposed target production temperature range (not to exceed 50°F) will be provided for each mix design.
- o. Name and responsibilities of the Responsible onsite Paving Supervisor.
- p. Method for calibration/verification of Density Gauge
- q. A note that all testing will be done in accordance with AASHTO and the MaineDOT Policies and Procedures for HMA Sampling and Testing.
- r. A detailed description of RAP processing, stockpiling and introduction into the plant as well as a note detailing conditions under which the percent of RAP will vary from that specified on the JMF.
- s. A detailed procedure outlining when production will be halted due to QC or Acceptance testing results.
- t. A plan to address the change in PGAB source or supplier and the potential co-mingling of differing PGAB's.
- u. A procedure to take immediate possession of acceptance samples once released by MaineDOT and deliver said samples to the designated acceptance laboratory.
- v. Provisions for how the QCP will be communicated to the Contractor's field personnel

The Contractor shall cease paving operations whenever one of the following occurs on a lot in progress:

- a. Method A: The Pay Factor for VMA, Voids @ N_d , Percent PGAB, composite gradation, VFB, fines to effective binder or density using all Acceptance or all Quality Control tests for the current lot is less than 0.85. No ceasing of paving operations shall be required for fines to effective binder if the mean test value is equal to the LSL or USL and $s = 0$.
- b. Method B: The Pay Factor for VMA, Voids @ N_d , Percent PGAB, composite gradation, VFB, fines to effective binder or density using all Acceptance or all Quality Control tests for the current lot is less than 0.90. No ceasing of paving operations shall be required for fines to effective binder if the mean test value is equal to the LSL or USL and $s = 0$.
- c. Method C: The Pay Factor for Percent PGAB, percent passing the nominal maximum sieve, percent passing 2.36 mm sieve, percent passing 0.300 mm sieve, percent passing 0.075 mm sieve or density using all Acceptance or all available Quality Control tests for the current lot is less than 0.85. No ceasing of paving operations shall be required for percent passing the nominal maximum sieve, percent passing 2.36 mm sieve, percent passing 0.300 mm sieve, or percent passing 0.075 mm sieve if the mean test value is equal to the LSL or USL and $s = 0$.
- d. The Coarse Aggregate Angularity or Fine Aggregate Angularity value falls below the requirements of Table 3: Aggregate Consensus Properties Criteria in Section 703.07 for the design traffic level.
- e. Each of the first 2 control tests for a Method A or B lot fall outside the upper or lower limits for VMA, Voids @ N_d , or Percent PGAB; or under Method C, each of the first 2 control tests for the lot fall outside the upper or lower limits for the nominal maximum, 2.36 mm, 0.300 mm or 0.075 mm sieves, or percent PGAB.
- f. The Flat and Elongated Particles value exceeds 10% by ASTM D4791.
- g. There is any visible damage to the aggregate due to over-densification other than on variable depth shim courses.
- h. The Contractor fails to follow the approved QCP.

401.203 Method C Lot Size will be the entire production per JMF for the project, or if so agreed at the Pre-paving Conference, equal lots of up to 4500 tons, with unanticipated over-runs of up to 1500 ton rolled into the last lot. Sublot sizes shall be 750 ton for mixture properties, 500 ton for base or binder densities and 250 ton for surface densities. The minimum number of sublots for mixture properties shall be 4, and the minimum number of sublots for density shall be five.

TABLE 7: METHOD C ACCEPTANCE LIMITS

Property	USL and LSL
Passing 4.75 mm and larger sieves	Target +/-7%
Passing 2.36 mm to 1.18 mm sieves	Target +/-5%
Passing 0.60 mm	Target +/-4%
Passing 0.30 mm to 0.075 mm sieve	Target +/-2%
PGAB Content	Target +/-0.4%
% TMD (In place density)	95.0% +/- 2.5%

Pay Adjustment Method C

The Department will use density, Performance Graded Asphalt Binder content, and the percent passing the nominal maximum, 2.36 mm, 0.300 mm and 0.075 mm sieves for the type of HMA represented in the JMF. If the PGAB content falls below 0.80, then the PGAB pay factor shall be 0.55.

Density: For mixes having a density requirement, the Department will determine a pay factor using Table 7: Method C Acceptance Limits:

$$PA = (\text{density PF} - 1.0)(Q)(P) \times 0.50$$

PGAB Content and Gradation The Department will determine a pay factor using Table 7: Method C Acceptance Limits. The Department will calculate the price adjustment for Mixture Properties as follows:

$$PA = (\% \text{ Passing Nom. Max PF} - 1.0)(Q)(P) \times 0.05 + (\% \text{ passing 2.36 mm PF} - 1.0)(Q)(P) \times 0.05 + (\% \text{ passing 0.30 mm PF} - 1.0)(Q)(P) \times 0.05 + (\% \text{ passing 0.075 mm PF} - 1.0)(Q)(P) \times 0.10 + (\text{PGAB PF} - 1.0)(Q)(P) \times 0.25$$

401.223 Process for Dispute Resolution (Methods A B & C only)

TABLE 10: DISPUTE RESOLUTION VARIANCE LIMITS

PGAB Content	+/-0.4%
G _{mb}	+/-0.030
G _{mm}	+/-0.020
Voids @ N _d	+/-0.8%
VMA	+/-0.8%
Passing 4.75 mm and larger sieves	+/- 4.0%
Passing 2.36 mm to 0.60 mm sieves	+/- 3.0%
Passing 0.30 mm to 0.15	+/- 2.0 %
0.075 mm sieve	+/- 0.8%

SPECIAL PROVISION
SECTION 401
HOT MIX ASPHALT PAVEMENT
(Material Transfer Vehicle)

Description The hot mix asphalt pavement for all leveling, base, binder and wearing courses shall be transferred to the paver by a material transfer vehicle (MTV) on mainline travelways, shoulders, and ramps as denoted in Special Provision 403 - Hot Mix Asphalt Pavement.

The MTV shall operate as an independent unit not attached to the paver. It shall be a commercially manufactured unit specifically designed to transfer the hot mix from haul trucks to the paver without depositing the mix on the roadway. A separate hopper with a capacity of 14 ton shall be inserted into the regular paver hopper. The MTV or the hopper insert shall be designed so that the mix receives additional internal mixing action either in the MTV unit or the paver hopper.

Basis of Payment The MTV and the hopper insert will not be paid for directly, but will be considered incidental to the related contract pay items.

SPECIAL PROVISION
SECTION 403
HOT MIX ASPHALT

Desc. Of Course	Grad Design.	Item Number	Total Thick	No. Of Layers	Comp. Notes
<u>1 ½” HMA Overlay with Shim</u>					
<u>Mainline Travelway & Shoulders (As Indicated in Typical)</u>					
Wearing	12.5 mm	403.2081	1½”	1	6,8,19,30
Shim	9.5 mm	403.211	Variable	1	1,4,10
<u>Bridge Approaches – 8” HMA Overlay</u>					
<u>Mainline Travelway</u>					
Wearing	12.5 mm	403.2081	1 ½”	1	6,8,19,30
Intermediate	12.5 mm	403.2131	1 ½”	1	6,8,30
Base	12.5 mm	403.2131	5”	2	6,8,30
<u>Bridge Approaches – 3” HMA Overlay</u>					
<u>Mainline Shoulders</u>					
Wearing	12.5 mm	403.2081	1 ½”	1	6,8,16,19,30
Base	12.5 mm	403.2131	1 ½”	1	6,8,16,30

COMPLEMENTARY NOTES

1. The required PGAB for this mixture will meet a **PG 64-28** grading.
4. The design traffic level for mix placed shall be 0.3 to <3 million ESALS. The design, verification, Quality Control, and Acceptance tests for this mix will be performed at **50 gyrations**.
6. The design traffic level for mix placed shall be 10 to <30 million ESALS. The design, verification, Quality Control, and Acceptance tests for this mix will be performed at **75 gyrations**.
8. Section 106.6 Acceptance, (2) Method B. The Contractor may request a contract modification to change to testing method “A” prior to work starting on this item.
10. Section 106.6 Acceptance, (2) Method D.
16. In areas inaccessible to a **10 ton** roller, compaction of the new Hot Mix Asphalt Pavement will be obtained using a minimal roller train consisting of a **3-5 ton** vibratory roller. Areas less than 2 feet wide shall be compacted with a minimum of a **150 pound** plate compactor. An approved release agent is required to ensure the mixture does not adhere to hand tools, rollers, pavers, and truck bodies. The use of petroleum based fuel oils, or asphalt stripping solvents will not be permitted.
19. The use of a Material Transfer Vehicle (MTV) shall be required on this layer. See Special Provision 401 – Material Transfer Vehicle for specifics.
30. The required PGAB shall be a storage-stable, homogeneous, polymer modified asphalt binder that meets **PG 64E-28** grading requirements in AASHTO M 332. All polymer modified asphalt grades utilized on the Project shall be treated with an approved liquid anti-strip. PG binders shall be treated either at the asphalt source terminal with the required dose rate on the delivery documentation, or at the hot mix asphalt plant utilizing a system integrated with the plants controls that will introduce a minimum 0.50 percent anti-strip by weight of asphalt binder used unless a rate is otherwise recommended by the anti-strip manufacturer. The PGAB and anti-strip blend shall meet the **PG 64E-28** requirements. The Contractor shall provide supporting test data showing the PGAB and anti-strip blend meet the required criteria.

Tack Coat

A tack coat of emulsified asphalt, RS-1, RS-1h, CRS-1 or CRS-1h, Item 409.15 shall be applied to any existing pavement at a rate of approximately 0.030 gal/yd², and on milled pavement approximately 0.05 gal/yd² prior to placing a new course. A fog coat of emulsified asphalt shall be applied between shim /base courses and surface course as well as to any bridge membrane prior to the placement of HMA layers at a rate not to exceed 0.030 gal/yd². Cleaning objectionable material from the pavement and furnishing and applying Item 409.15 bituminous materials to joints and contact surfaces is incidental to the contract paving items.

SPECIAL PROVISION
SECTION 603
 PIPE CULVERTS AND STORM DRAINS

603.12 Basis of Payment: This section shall be amended with the addition of the following:

<u>Pay Item</u>		<u>Pay Unit</u>
603.155	12 Inch Reinforced Concrete Pipe Class III	Linear Foot
603.165	15 Inch Reinforced Concrete Pipe Class III	Linear Foot
603.175	18 Inch Reinforced Concrete Pipe Class III	Linear Foot
603.1752	18 Inch Reinforced Concrete Pipe Class IV	Linear Foot
603.19	24 Inch Culvert Pipe Option I	Linear Foot
603.195	24 Inch Reinforced Concrete Pipe Class III	Linear Foot
603.205	30 Inch Reinforced Concrete Pipe Class III	Linear Foot
603.215	36 Inch Reinforced Concrete Pipe Class III	Linear Foot
603.225	42 Inch Reinforced Concrete Pipe Class III	Linear Foot
603.235	48 Inch Reinforced Concrete Pipe Class III	Linear Foot
603.245	54 Inch Reinforced Concrete Pipe Class III	Linear Foot
603.255	60 Inch Reinforced Concrete Pipe Class III	Linear Foot
603.431	36 Inch Reinforced Concrete Pipe Class V	Linear Foot

SPECIAL PROVISION
SECTION 606
GUARDRAIL

606.09 Basis of Payment: This section shall be amended with the addition of the following:

<u>Pay Item</u>	<u>Pay Unit</u>
606.1301 31" W-Beam Guardrail - Mid-Way Splice (Steel Post, 8" Offset Blocks, Single Faced)	Linear Foot
606.1302 31" W-Beam Guardrail - Mid-Way Splice (Steel Post, 8" Offset Blocks, Double Faced)	Linear Foot
606.1303 31" W-Beam Guardrail - Mid-Way Splice (Steel Post, 8" Offset Blocks, 15' Radius and Less)	Linear Foot
606.1304 31" W-Beam Guardrail - Mid-Way Splice (Steel Post, 8" Offset Blocks, Over 15' Radius)	Linear Foot
606.1305 31" W-Beam Guardrail - Mid-Way Splice Flared Terminal (31" Height)	Each
606.1306 31" W-Beam Guardrail - Mid-Way Splice Tangent Terminal (31" Height)	Each
606.1307 Bridge Transition (Asymmetrical) – Type 1	Each
606.1308 Buried-in-Slope Guardrail End, Mid-Way Splice	Each

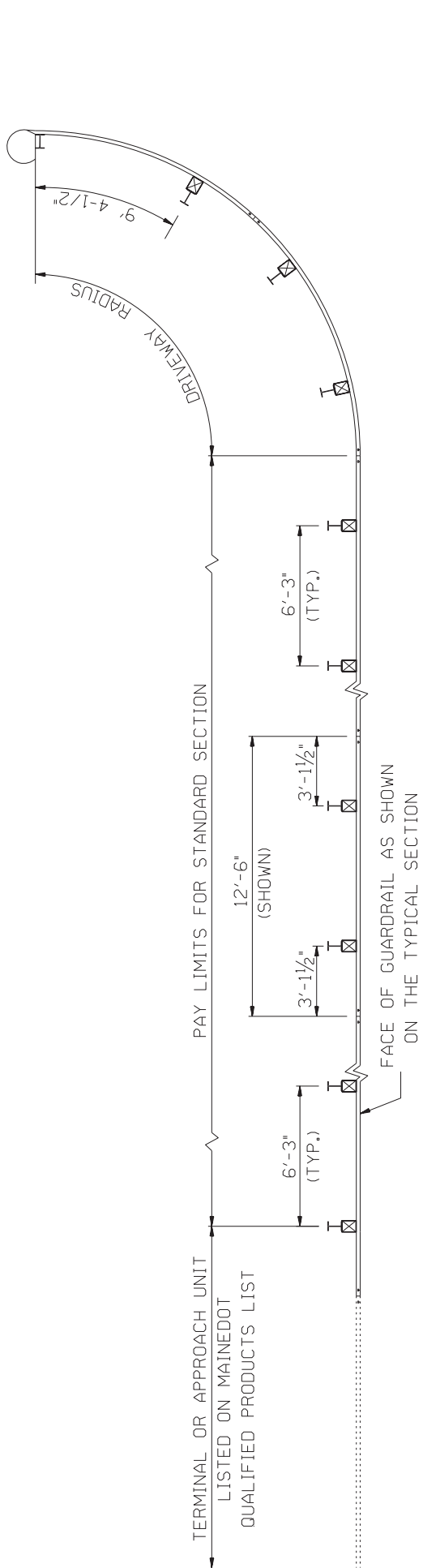

PLAN

W 6x9.0 OR W 6x8.5 STEEL POST WITH 6" x 8" WOOD OFFSET BLOCK OR OTHER 8" BLOCK LISTED ON MAINEDOT QUALIFIED PRODUCTS LIST (TYP.)

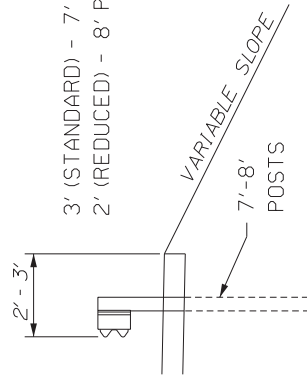
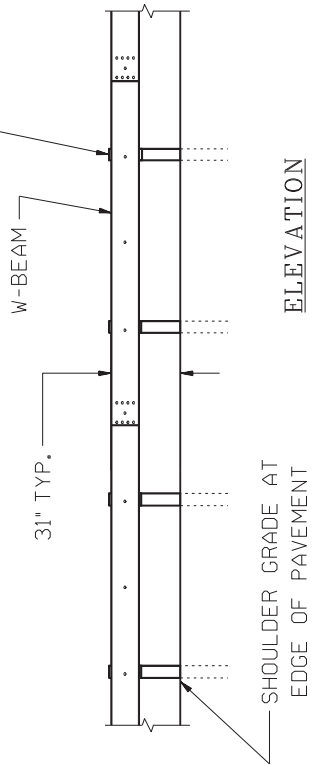

CROSS SECTION

31" W-BEAM GUARDRAIL - MID-WAY SPLICE

SPECIAL PROVISION
SECTION 606
GUARDRAIL

(LINEAR DELINEATION SYSTEM)

Description This work shall consist of furnishing and installing linear delineation system panels on w-beam guardrail.

Materials Each linear delineation system panel shall be 1.5 inches wide by approximately 11 inches nominal length, with a minimum of 5 raised lateral ridges spaced at approximately 2.25 inches. The height of each ridge shall be 0.34 inches with a 45 degree profile and a 0.28 inches radius at the top. Reflective sheeting shall be white or fluorescent yellow and shall meet the applicable requirements of Standard Specification 719.01. Sheeting shall be laminated to thin gauge aluminum with a pre-applied adhesive tape on the back.

Construction Requirements Linear delineation system panels shall be applied at approximately 62.5 foot intervals on tangents (after every tenth post) and 31.25 feet on curves (after every fifth post), and shall be centered vertically on the guardrail beam. Panels shall not be applied to seams or bolt heads; each panel shall be fully attached to only one guardrail beam. The guardrail beam surface shall be cleaned and prepared according to the manufacturer's instructions. Application air temperature and guardrail surface temperature must be a minimum of 50 degrees F (10 C) with rising temperature.

On two directional highways, panels shall be white on both sides of the highway. On one-way or divided highways panels shall be yellow on the left and white on the right.

Basis of Payment Linear delineation system panels shall be considered incidental to the new guardrail item and no additional payment shall be made.

Special Provision
Section 627
Preformed Thermoplastic Pavement Markings

627.02 – Materials

Add:

“Preformed thermoplastic pavement marking shall meet the requirements of **PreMark® Thermoplastic Pavement Markings**, 125 mil thickness, manufactured by Flint Trading, Inc. (115 Todd Court, Thomasville, NC 27360 Tel 336-475-6600) or an approved equal. Materials must be kept dry at all times before installation and must be stored flat, indoors, and at temperatures between 35° and 90°F.

A compatible epoxy sealer (such as EP 2-Part Sealer) shall be used for all Preformed Thermoplastic Pavement Marking applications.”

627.05 – Preparation of Surface

Add:

“Grind pavement areas on which thermoplastic marking are to be applied to a depth of 188 mils (3/16 inch), plus or minus 5 mils, to receive the markings. Grinding shall cover all area to be marked but shall keep excess area outside of pavement lines and symbols to a minimum. The bottom of the groove shall have a smooth, flat finished surface. The use of gang stacked Diamond cutting blades is required for asphalt pavement surfaces. The spacers between blade cuts shall be such that there will be less than a 10 mil rise in the finished groove between the blades.

All debris resulting from the installation of the grooves shall be removed and disposed of by the contractor.”

627.06 – Application

Add:

“Ambient and surface temperature must be at least 50°F at the time of epoxy sealer application.”

627.07 – Establishment Period

Remove section 627.07 in its entirety.

Add:

“Inlaid plastic pavement lines and marking material furnished and installed under this contract for final pavement markings shall be subject to a twelve-month period of establishment.

The period of establishment shall commence as soon as the plastic pavement lines and markings are complete and in place and shall continue for twelve months. At the end of the establishment period, a minimum of 95% of each plastic pavement line or marking shall still be in place to be acceptable.

If less than 95% of a plastic line or marking is in place after twelve months, the Contractor shall replace or repair each unsatisfactory plastic pavement line or marking on the project without additional payment. Plastic pavement lines and markings designated for replacement or repair shall be installed according to these specifications, unless otherwise directed. Plastic pavement lines and markings replaced or repaired at the end of the twelve-month establishment period will not be subject to a further establishment period.”

627.09 – Method of Measurement

Add:

“Preformed Thermoplastic Pavement Markings will be measured by the square foot complete and in place.”

627.10 – Basis of Payment

Remove the second paragraph of section 627.10 in its entirety, and replace with:

“Payment for final plastic pavement lines and markings will be made at the contract unit price per square foot. Payment will be considered full compensation for all labor, equipment, and material necessary to complete the described work, including loading, hauling, stockpiling and disposal of material.”

Pay Item

627.941

Preformed Thermoplastic Pavement Markings – Recessed

Pay Unit

Square Foot”

PROJ. MANAGER	SHAWN SMITH	DATE
CHECKED BY	A. GORRACCI	
DESIGNED BY		
DESIGNED DATE		
DESIGNED TIME		
REVISIONS 1		
REVISIONS 2		
REVISIONS 3		
REVISIONS 4		
DATE		
SIGNATURE		
P.E. NUMBER		

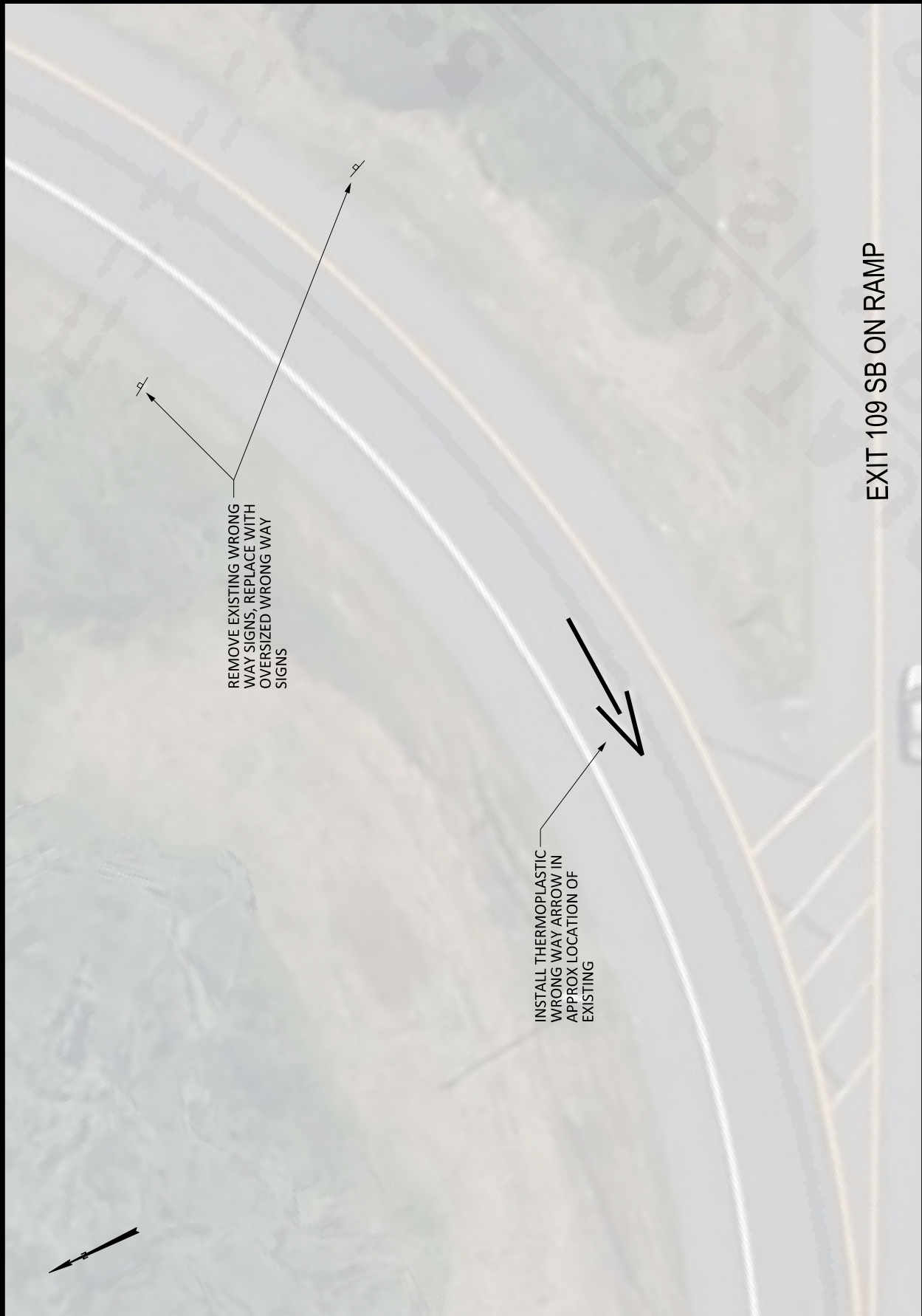

REMOVE EXISTING WRONG
 WAY SIGNS, REPLACE WITH
 OVERSIZED 'WRONG WAY'
 SIGNS

INSTALL THERMOPLASTIC
 WRONG WAY ARROW IN
 APPROX LOCATION OF
 EXISTING

EXIT 109 SB ON RAMP



**Special Provision
Section 645
Highway Signing**

Existing signs to be relocated are presently located on the Exit 109 Northbound Off Ramp, left & right. Signs are proposed to be relocated for the Exit 109 A Southbound Off Ramp. Locations shall be determined in the field by the Department.

<u>Pay Item</u>		<u>Pay Unit</u>
645.1061	Relocate Existing Sign Assembly and Post	Each

**Special Provision
Section 645
Highway Signing**

All signs removed as part of this project shall be delivered to the MaineDOT Sign Shop, located at 66 Industrial Drive, Augusta, Maine.

<u>Pay Item</u>		<u>Pay Unit</u>
645.109	Remove and Salvage Highway Signs	Each

SPECIAL PROVISION
SECTION 645
HIGHWAY SIGNING
(Flexible Reflectorized Delineator)

Description This work shall consist of furnishing and installing flexible reflectorized delineators in accordance with the Manufacturer's recommendations in reasonably close conformity with the plans and specifications.

Materials Flexible reflectorized delineators shall be one of the following:

<u>Manufacturer</u>	<u>Model</u>
Safe-Hit Corp.	Safe-Hit Co-extruded Type SH248GP3
	Safe-Hit Co-extruded Type SH254GP3
	Safe-Hit Co-extruded Type SH348GP3

Construction Requirements Flexible delineators shall be installed in accordance with Section 645.062 Installation of Delineators, except that the mounted height of the delineator shall be 1200 mm [4 ft] above the edge of shoulder.

Method of Measurement Flexible reflectorized delineators will be measured by the number of units complete in place.

Basis of Payment The accepted reflectorized delineators will be paid for at the contract unit price each. Such payment will be full compensation for furnishing and installing the delineator and all associated hardware complete in place.

Payment will be made under:

<u>Pay Item</u>	<u>Pay Unit</u>
645.306 Flexible Reflectorized Delineator	Each

**Special Provision
Section 645
Highway Signing**

645.021 – Materials

Add:

“ASTM D4956-13, Type XI sheeting shall be used on wrong way signs (MUCTD R5-1a)”

SPECIAL PROVISION
SECTION 652
MAINTENANCE OF TRAFFIC

Approaches. Approach signing for the work on the Interstate shall include the following signs

Road Work 3 Miles	Road Work 500 Feet
Road Work 2 Miles	Road Work Next x Miles
Road Work 1 Mile	End Road Work

Work Areas Interstate. At the work sites, signs, flashing arrow boards, and channeling devices as shown on the Work Zone Signing details shall be used as directed by the Resident.

Signs Include:

Right or Left Lane Closed 2 Miles
Lane Ends 1 mile Merge Right or Left Now
Right or Left Lane Closed 1/2 Mile
Speed Limit 55***¹ (Existing speed limit signs will be covered when in use)
Fines Doubled*
Work Zone¹
Do Not Pass*
Right/Left Merge Symbol (W 4-2)
End Work Zone¹
Resume Speed
Exit (green with white legend and border)
Road Work Ahead¹
Merging Traffic Symbol (At on-ramp in right lane closure)
Stop Ahead (At on-ramp in right lane closure)
Single Lane Ahead (At on-ramp in left lane closure)
Stop (At on-ramp in right lane closure)
Directional Arrows (At on-ramp in right lane closure)
Detour
End Detour
Bump
Trucks Entering
Stay In Lane*
Left Turning Trucks with 500 Feet Advisory Plate
Flagger Sign
Grooved Pavement
Caution Rumble Strip
Uneven Lanes
Motorcycles Use Caution

Signs (continued)

* White with black legend and border

¹ In addition to work zone package these signs will also be required at the end of any on ramps that are within the lane closure

The preceding list of Approach signs and Work Area signs are representative of the contract requirements. Other sign legends may be required.

General Requirements-Interstate.

The Contractor shall provide a minimum traveled way width of 14 Feet through an expressway lane closure.

The maximum length of lane closure shall be 3 miles in length.

See Special Provision 105 for lane closures.

All construction work shall be confined to the lane closed to traffic.

Slow moving construction equipment may travel the closed lane for short distances, **ALL** vehicles shall be orientated with the flow of traffic unless otherwise authorized by the Resident.

Any vehicle using LED Lights shall have them angled as to not to impeded or disrupt normal traffic flow at any time as determined by the Resident. Vehicles unable to manipulate these devices shall be removed from the project immediately.

All trucking shall be done in the lane open to traffic.

No equipment or vehicles of the Contractor, his Subcontractor or employees engaged in work on this contract, shall be parked or stopped on lanes carrying traffic, or on lanes or shoulders adjacent to lanes carrying traffic, at any time.

The Contractor shall keep all paved areas of the roadway as clear as possible at all times. The Contractor's personnel and equipment shall avoid crossing traffic lanes whenever possible.

Road Work Ahead signs shall be used on roads adjacent to the interstate when the Contractor is working on or near an on-ramp or when the on-ramp enters a lane closure area.

Off shift lane closures shall not be permitted.

All temporary pavement marking lines or markers will be paid under Item 627.781 Temporary 6 Inch Painted Pavement Marking Line, White or Yellow or Item 627.78 Temporary 4 Inch Painted Pavement Marking Line, White or Yellow. TOM's will not be permitted.

12:1 paved tapers constructed of Hot Mix Asphalt shall be placed at all ramps immediately following milling and paving. Millings shall not be used.

Use of Interstate Crossovers shall not be allowed.

The Contractor, his Subcontractor or employees shall conduct all work in a safe and professional manner as it relates to the traveling public (i.e. not adversely disrupting the flow of traffic in an unsafe manner when exiting or entering a lane closure or crossover, negative verbal or physical gestures).

The intent is that attenuator vehicles are to be used at all stationary operations and under most circumstances. They shall be rated for highway speeds. They shall be used in accordance with manufacturers' recommendations. The use of these vehicles shall be written into the contractor's traffic control plan. The cost for these vehicles shall be considered incidental to the traffic control plan. An example would be culvert work or guardrail replacement. Maximum distance between operations and attenuator vehicles will be 500'. Attenuators shall be present at the beginning of paving and milling operations. The cost for these vehicles shall be considered incidental to Item 652.36.

Item 652.47 Temporary Portable Rumble Strips shall be deployed during approach sign set up.

Channelization. Channelization devices shall include the following:

Flashing Arrow Boards

Vertical Panel Markers

Drums (**In lane closures, The contractor shall place 3 drums across a closed lane every 1500'.**)

Cones (**During actual working time, the contractor may use cones in the work areas in lieu of Drums with the exception of tapers**)

Channelization devices shall be installed and maintained at the spacing determined by the MUTCD to delineate travel lanes through the project. Vertical Panel markers shall be placed 2 feet from the outside edge of the shoulder on the passing lane at 600 foot intervals when the travel lane is closed in overnight lane closures. The vertical panel marker size shall be 12 inches x 36 inches. The bottom of these panels shall be 4' from the ground below. When directed by the Engineer, drums or other channelization devices shall be placed in the closed lane at a maximum spacing of 2 x speed limit.

Temporary Centerline or Edge Line. A temporary painted centerline and edge line shall be marked each day on all milled surfaces or new pavement to be used by traffic. The temporary line shall conform to the standard marking patterns used for permanent markings and will be paid for under Section 627. Failure to apply a temporary line daily will result in suspension of milling or paving until temporary markings are applied to all previously milled surfaces or placed pavement. In the event of inclement weather that would prevent markings to be applied, MaineDOT will determine the procedure to be followed and whether additional pavement may be removed or placed based upon safety, traffic volumes and patterns.

Item 627.30 Grooving for Pavement Markings must have a temporary painted centerline and edge line applied within according to the following guidelines:

One line grooved	48 hours of grooving
Two or more lines grooved	24 hours of grooving

Under no circumstances shall this time span over a weekend or a no work period. Failure to comply with this will result in a traffic control violation until such line has been marked.

Roadside Recovery Area. The Contractor shall not store material nor park equipment within 15 feet of the edge of the established travel lanes.

No long term storage of equipment or material will be allowed within 30 feet of the edge of the established travel lanes. Short term storage of equipment or material less than 30 feet from the edge of the established travel lanes must be approved by the Department and shall be clearly marked by **drums and cones**. Short term storage shall be defined as less than 12 hours. No equipment or material will be allowed within 30 feet of the edge of the established travel lanes at night.

Speed Limits in Work Zones. The Contractor shall sign all approved reduced speed limits on construction project according to APM #431 - A Policy on the Establishment of Speed Limits in Work Zones.

WORK ZONE SIGNING

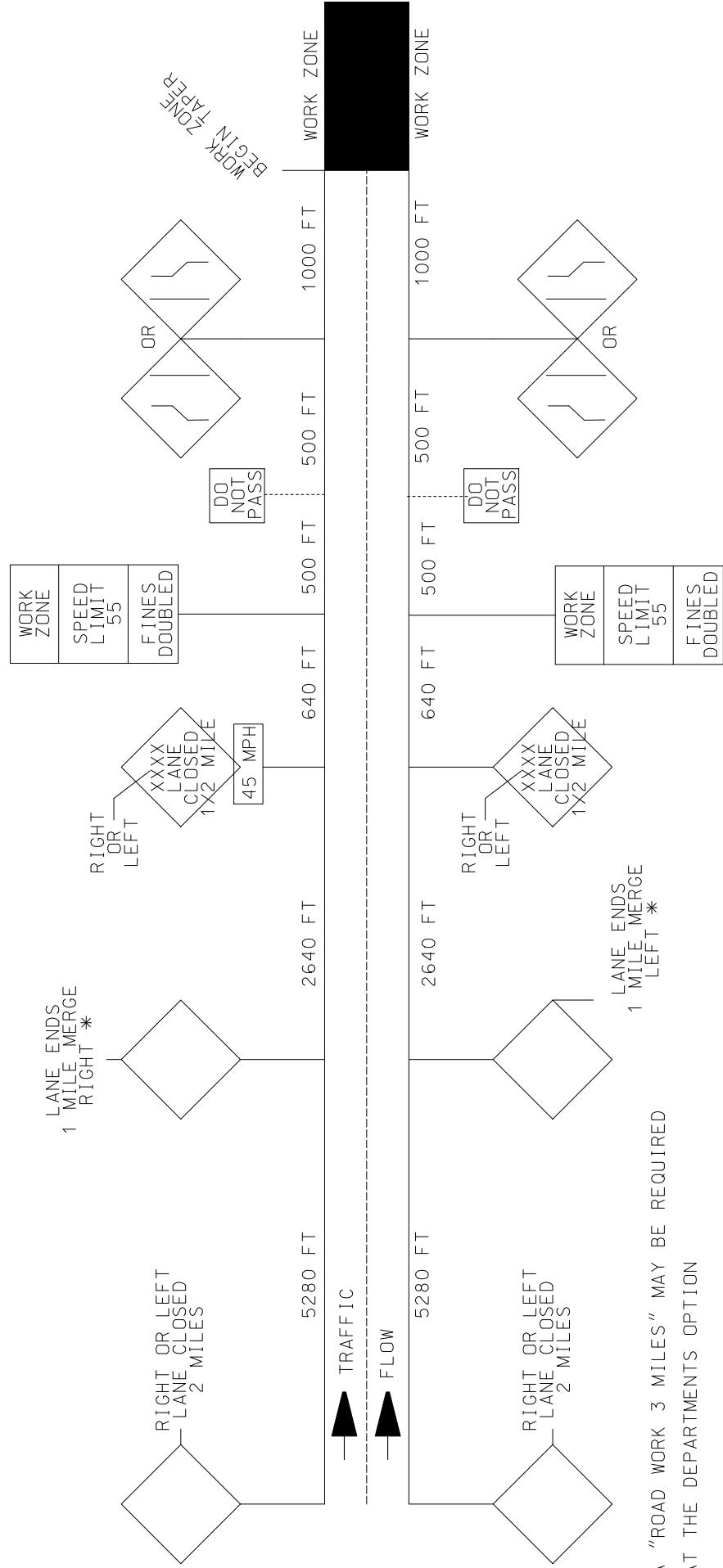

A "ROAD WORK 3 MILES" MAY BE REQUIRED AT THE DEPARTMENT'S OPTION

* LANE ENDS 1 MILE MERGE RIGHT OR LEFT SIGNS SHALL ONLY BE PLACED ON SIDE OF ROAD THAT NEEDS TO MERGE

WORK ZONE

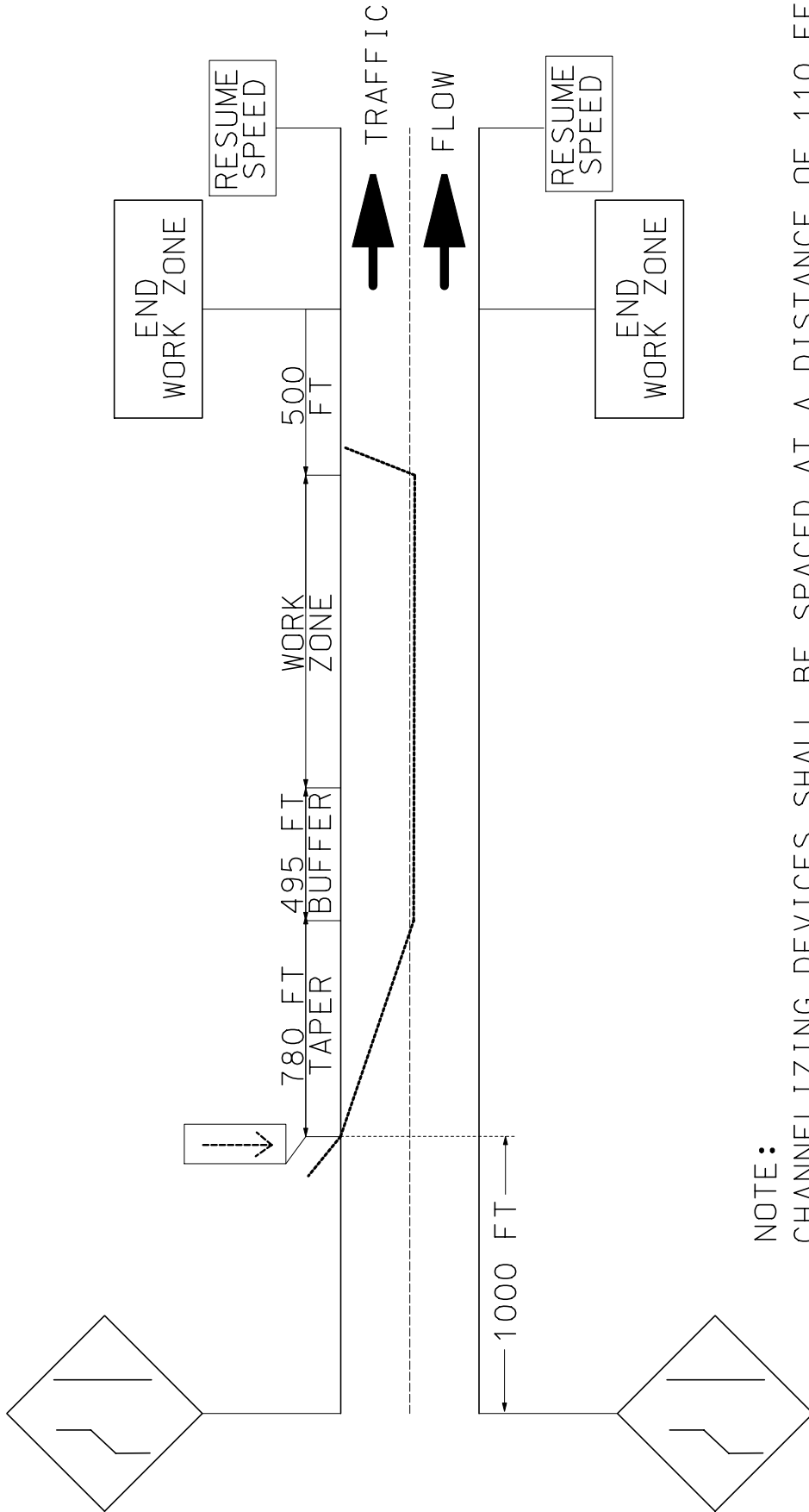

NOTE:
 CHANNELIZING DEVICES SHALL BE SPACED AT A DISTANCE OF 110 FEET
 APART WITH 3 DEVICES ACROSS THE CLOSED LANE EVERY 1500 FEET.
 DEVICES IN THE TAPER SHALL BE SPACED AT 55 FEET APART.

RAMPS - RIGHT LANE CLOSED

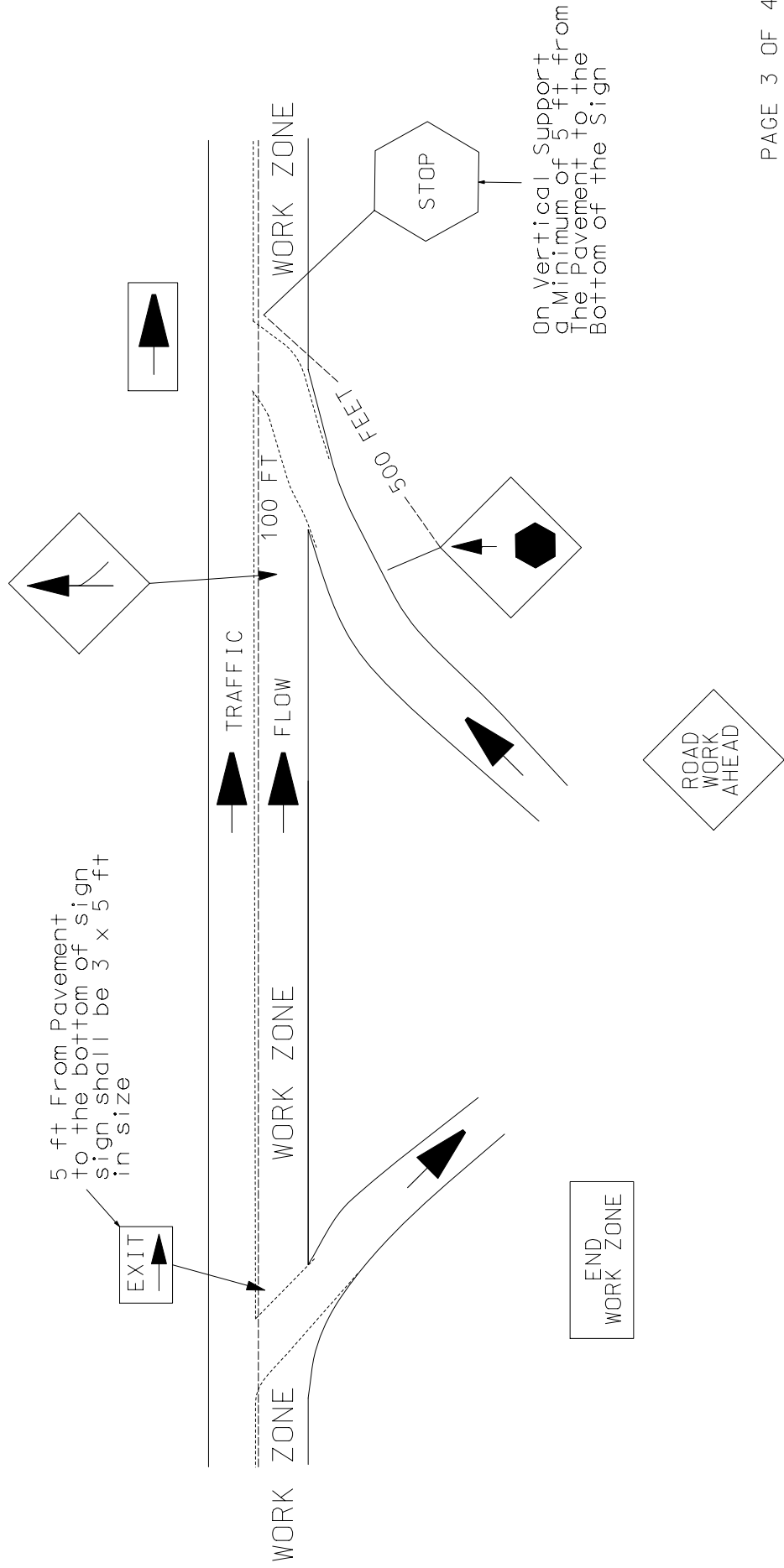

RAMPS - LEFT LANE CLOSED

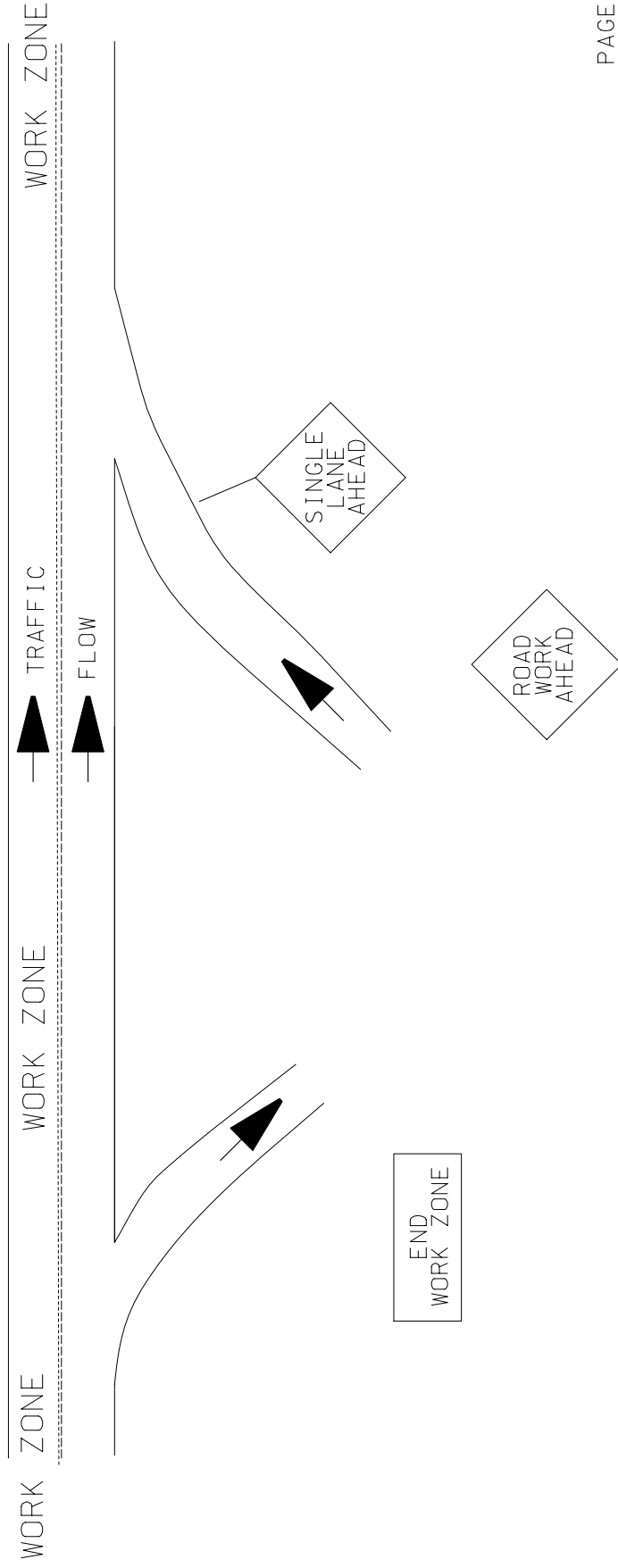

SPECIAL PROVISION
SECTION 652
MAINTENANCE OF TRAFFIC

Approaches. Approach signing shall include the following signs at a minimum. Field conditions may warrant the use of additional signs as determined by the Resident.

Road Work Next X* Miles
Road Work 500 Feet (Ahead)
End Road Work

Work Areas. At each work site, signs and channelizing devices shall be used as directed by the Resident.

Signs include:

Road Work xxxx¹.
One Lane Road Ahead
Flagger Sign

Other typical signs include:

Be Prepared to Stop
Low Shoulder
Bump
Pavement Ends

The above lists of Approach signs and Work Area signs are representative of the contract requirements. Other sign legends may be required.

The Contractor shall conduct their operations in such a manner that the roadway will not be restricted to one lane for more than 2,500 feet at each work area. To encourage quality paving in warm-weather conditions, the length can be extended to 4,000 feet depending on the traffic impacts. Where more than one work area restricts traffic to one lane operation, these work areas shall be separated by at least 1 mile of two way operation.

Temporary Centerline A temporary centerline shall be placed each day on all new pavement to be used by traffic. The temporary centerline, when specified of reflectorized traffic paint, shall conform to the standard marking patterns used for permanent markings. Failure to apply a temporary centerline daily will result in a Traffic Control Violation and suspension of paving operations until temporary markers are applied to all previously placed pavement.

¹ “Road Work Ahead” to be used in short duration operations and “Road Work xx feet” to be used in stationary operations as directed by the Resident.

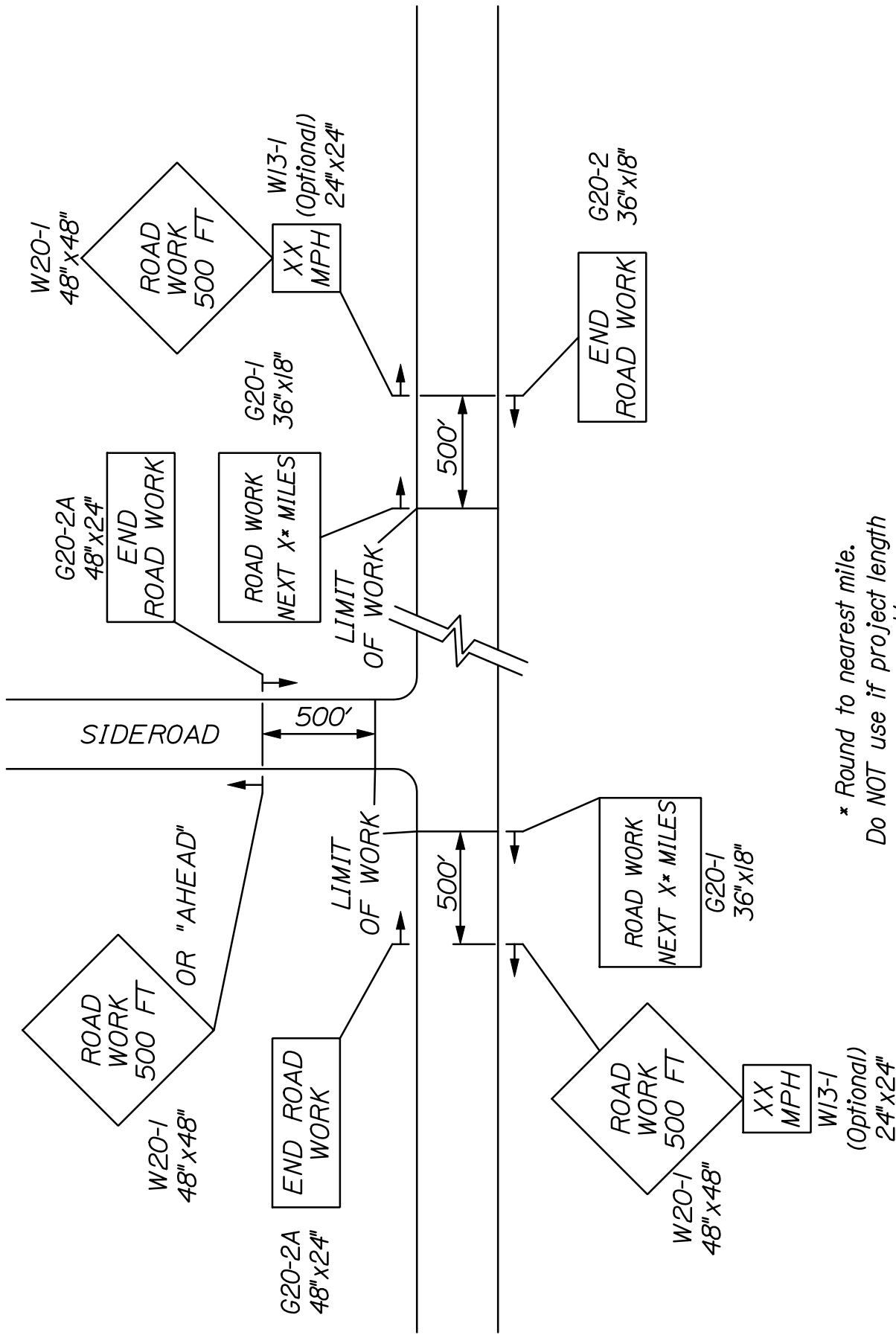

* Round to nearest mile.
 Do NOT use if project length
 is less than a 1/2 mile.

~ PROJECT APPROACH SIGNING ~
 TWO WAY TRAFFIC

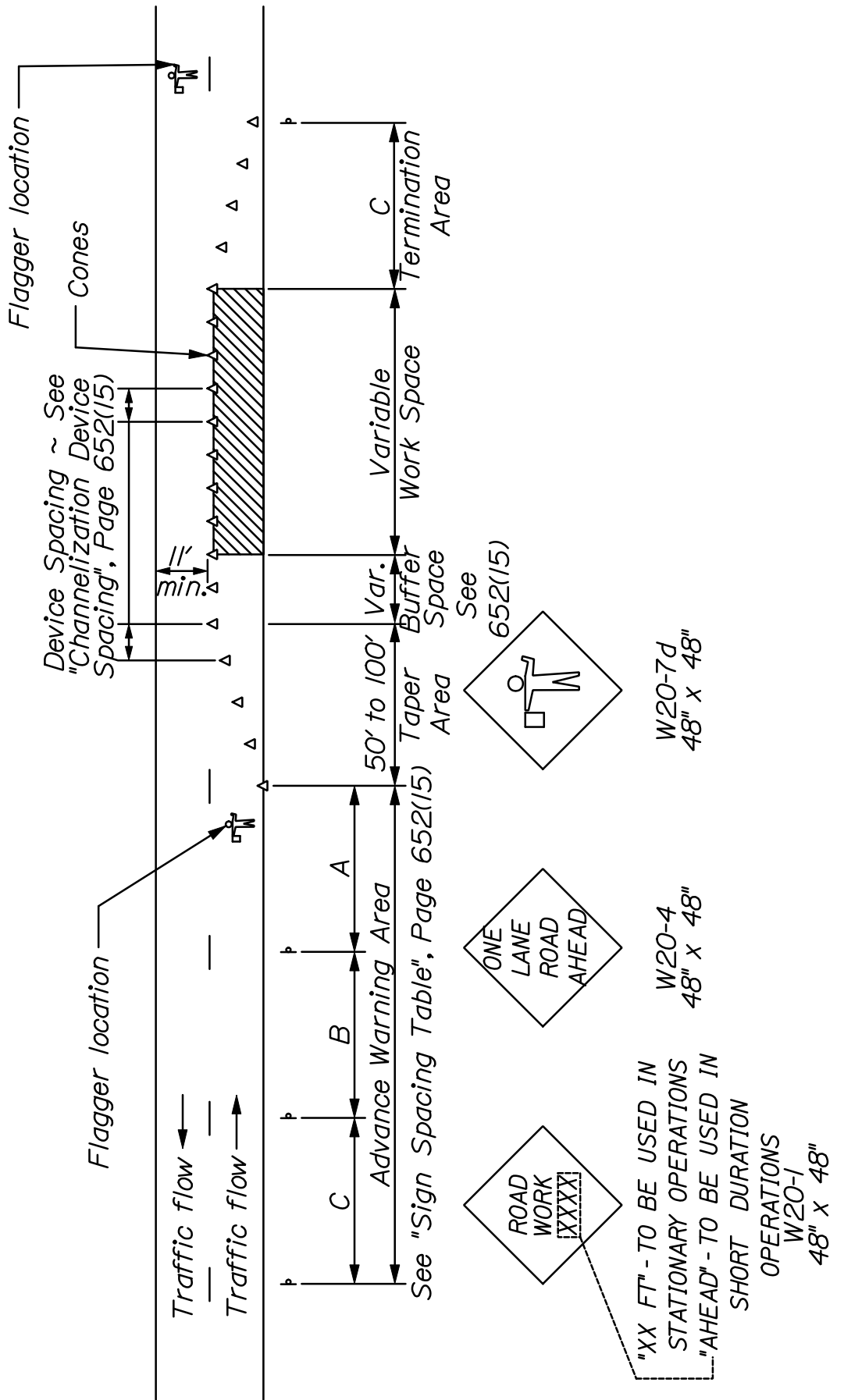

~ TYPICAL APPLICATION: TWO -WAY, TWO LANE ROADWAY,
 CLOSING ONE LANE USING FLAGGERS ~

* Formulas for L are as follows:
For speed limits of 40 mph or less:

$$L = \frac{WS^2}{60}$$

For speed limits of 45 mph or greater:

$$L = WS$$

* Formulas for L are as follows:

A minimum of 5 channelization devices shall be used in the taper.

TYPE OF TAPER	TAPER LENGTH (L)*
Merging Taper	at least L
Shifting Taper	at least 0.5 L
Shoulder Taper	at least 0.33 L
One-Lane, Two-Way Traffic Taper	100 ft maximum
Downstream Taper	100 ft per lane

CHANNELIZATION DEVICE SPACING

The spacing of channelization devices shall not exceed a distance in feet equal to 1.0 times the speed limit in mph when used for taper channelization, and a distance in feet of 2.0 times the speed limit in mph when used for tangent channelization.

GENERAL NOTES:

1. Final placement of signs and devices may be changed to fit field conditions as approved by the Resident.
2. Maintain same number of lanes for a shifting taper.
3. Shoulder taper allowed when a minimum of 10 feet can be open from centerline for lane.

Road Type	Distance Between Signs**		
	A	B	C
Urban 30 mph or less	100	100	100
Urban 35 mph and greater	350	350	350
Rural	500	500	500
Expressway / Urban Parkway	1000	1500	2640

**Distances are shown in feet.

SUGGESTED BUFFER ZONE LENGTHS

Speed (mph)	Length (feet)	Speed (mph)	Length (feet)
20	115	40	325
25	155	45	360
30	200	50	425
35	250	55	495

**SPECIAL PROVISION
SECTION 652
MAINTENANCE OF TRAFFIC
(Automated Speed Limit Sign)**

Item 652.45 – Automated Trailer-Mounted Speed Limit Sign

652.1 Description This special provision provides for furnishing, operating, and maintaining an Automated Trailer Mounted Radar Speed Limit Sign for project use. The Contractor shall furnish, operate, and maintain the Automated Trailer Mounted radar Speed Limit Signs during the project operations.

652.1.1 Instruction and maintenance manuals shall be provided.

652.2 Materials

Automated Trailer Mounted Speed Limit Sign

Trailer mounted speed limit signs shall be self-contained units including sign assembly, flashing lights, directional radar to measure speed limits, a regulatory speed limit sign, a construction sign stating “Work Zone Speed Limit When Flashing” and power supply specifically constructed to operate as a trailer-mounted sign. The preferred color of the unit shall be “construction orange”.

Signs Base material for the regulatory speed limit signs shall be weather proof, rigid substrate specifically manufactured for highway signing and meet the retro-reflective sheeting application requirements of the sheeting manufacturer.

Sign text shall consist of the letters, digits and symbols either applied by stick-on or silk screen, to conform to the dimensions and designs indicated in the Contract, MUTCD and/or FHWA Standard Highway Signs. The materials and methods shall be in accordance with standard commercial processes.

The regulatory sign should have changeable speed limit numbers.

“Work Zone” construction signs shall be mounted on the trailer unit above and below the regulatory speed limit sign. (see attached detail). The “When Flashing “construction sign shall be added to the trailer, if the Resident deems the sign necessary.

Signs and secondary signs shall follow the MUTCD for minimum mounting heights.

Power supply The power supply shall be either full battery power with solar panel charging (capable of maintaining a charged battery level) and 135 ampere, 12 volt deep cycle batteries, or diesel powered generator with a fuel capacity sufficient for 10 hours of continuous operation.

Flashing Lights Each unit shall be equipped with two mono-directional flashing lights, placed in accordance with the MUTCD, with amber lenses and reflectors, which are visible through a range of 120 degrees when viewed facing the sign. The lights, either strobe, halogen, or incandescent lamps, shall be visible for a minimum distance of one mile under daylight conditions and shall have a minimum flash rate of 40 flashes per minute. An “On” indicator light shall be mounted on the back of the signs, which is visible for at least 500 feet to provide confirmation that the flashing lights are operating.

Radar The directional radar shall monitor approaching traffic only. The radar shall be capable of measuring speeds from 5 to 70 MPH at a distance of up to 1500 feet and shall have a high speed cut off threshold.

CONSTRUCTION REQUIREMENTS

652.3.2 Responsibility of the Contractor The Contractor shall furnish the automated Trailer Mounted Speed Limit Sign as described in 2.1 for this project.

All existing speed limit signs, which conflict with the construction zone trailer mounted speed limit signs shall be covered completely during the operation of the flashing lights. These signs shall be immediately uncovered when the use of the flashing lights is discontinued.

Automated Trailer Mounted Speed Limit Signs shall be used only during the Contractor’s actual work hours, unless specifically authorized by the Engineer.

The Resident will record the actual time and location for the signs on a daily basis when the Automated Trailer Mounted Speed Limit Signs are in use.

Automated Trailer Mounted Speed Limit Signs shall be located as directed by the Resident. Placement of additional “Reminder” signs may be ordered by the Resident.

Automated Trailer Mounted Speed Limit Signs shall be placed outside the clear zone whenever practical and possible. The signs shall be removed outside the clear zone of the traveled way as specified in the Traffic Control Plan when not in use unless protected by portable barrier or equivalent. The signs shall be delineated with retro-reflective temporary traffic control devices while in use and shall also be delineated by affixing a retro-reflective material directly on the trailer.

Upon delivery of the Automated Trailer Mounted Speed Limit Sign and before acceptance by the Department, the Contractor shall have a representative of the manufacturer review the condition and notify the Resident in writing, of all deficiencies noted.

The Contractor shall arrange to have all necessary repairs performed at no cost to the Department.

To avoid impairing driver vision, the Contractor shall dim the lighted speed limit readings by 50 percent during nighttime use, and restore full power lighting during daytime operation.

METHOD OF MEASUREMENT

652.7 Method of Measurement Each Automated Trailer Mounted Speed Limit Sign will be measured as a unit.

A unit will include the unit as described in 2.1, the trailer, radar Speed Limit Sign, flashing beacon amber lights, regulatory speed limit sign, "Work Zone Speed limit when flashing" construction sign, fuel, necessary maintenance, and all checking of radar Speed Limit Signs by manufacturer. Also included are all project moves including the transporting and delivery of each unit.

BASIS OF PAYMENT

652.8 Basis of Payment The accepted quantity of Automated Trailer Mounted Speed Limit Sign will be paid for at the contract price per unit for the number of units used and accepted.

Payment will be made under:

Pay Item	Pay Unit
652.45 Automated Trailer Mounted Speed Limit Sign	Unit

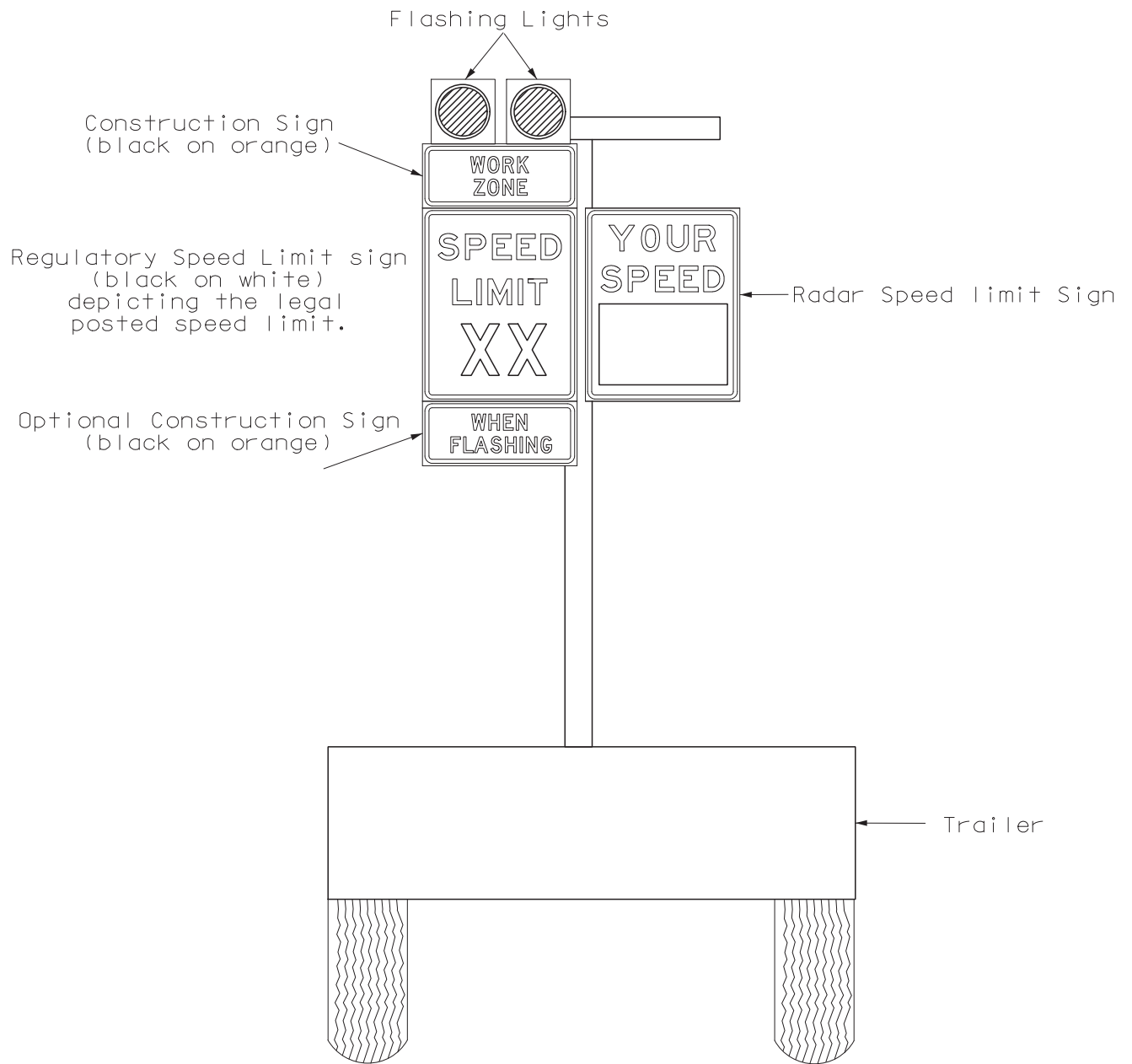

Automated Trailer Mounted Speed Limit Sign
note: not to scale

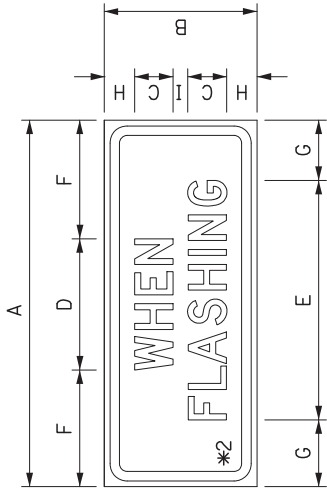
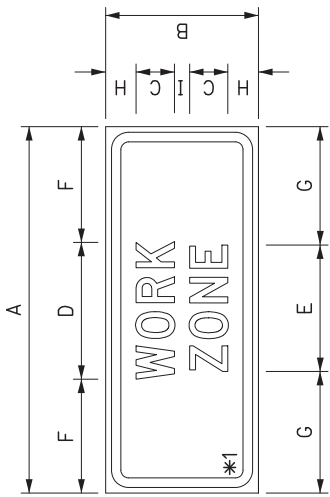

*1 - 1.25" BORDER, 0.75" INDENT, BLACK ON ORANGE; BB GRADE PLYWOOD SIGN
 *2 - 1.25" BORDER, 0.75" INDENT, BLACK ON WHITE; BB GRADE PLYWOOD SIGN
 *3 - 1.25" BORDER, 0.75" INDENT, BLACK ON WHITE; BB GRADE PLYWOOD SIGN

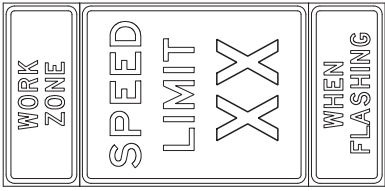

DIMENSIONS (inches) / LETTER FONTS

	A	B	C	D	E	F	G	H	I	J	K	L
*1	48	20	5D	18 1/8	16 5/8	14 7/8	15 5/8	4	2	N/A	N/A	N/A
*2	48	20	5D	17 1/4	31 3/8	15 1/2	8 1/4	4	2	N/A	N/A	N/A
*3	48	60	8E	16E	38 1/4	29 1/4	29 1/2	4 7/8	9 3/8	9 1/4	8	6

CONSTRUCTION SIGN/REGULATORY SIGNS

**TRAILER MOUNTED CONSTRUCTION ZONE
SPEED LIMIT SIGN**

SPECIAL PROVISION
SECTION 652
MAINTENANCE OF TRAFFIC

SEQUENTIAL FLASHING WARNING LIGHTS

Description Furnish and install Sequential Flashing Warning Lights on drums used for merging tapers during nightly work activities on interstates and freeways with speed limits greater than 55 MPH and or facilities that have significant traffic volumes.

The purpose of these lights is to assist the motorist in determining which direction to merge when approaching a lane closure. It's also designed to reduce the number of late merges resulting in devices being struck and having to be reset to maintain positive guidance at the merge point. The successive flashing of the lights shall occur from the upstream end of the merging taper to the downstream end of the merging taper in order to identify the desired vehicle path.

Materials The Sequential Flashing Warning Lights shall meet all of the requirements for warning lights within the current edition of the Manual of Uniform Traffic Control Devices (MUTCD).

Each light unit shall be capable of operating fully and continuously for a minimum of 200 hours when equipped with a standard battery set.

Each light in the sequence shall be flashed at a rate of not less than 55 times per minute and not more than 75 times per minute. The flash rate and flash duration shall be consistent throughout the sequence.

Supply a Type 3 Certification (Independent Test Lab results) documenting all actual test results for the specified parameters contained in the Institute of Transportation Engineer's (ITE's) *Purchase Specification for Flashing and Steady Burn Warning Lights*. The laboratory shall also identify all manufacturer codes and part numbers for the incandescent lamp or LED clusters, lenses, battery, and circuitry, and the total width of the light with the battery in place. The complete assembly shall be certified as crashworthy when firmly affixed to the channelizing device.

The Contractor shall submit for approval, literature and all necessary certifications to the Department prior to procurement of the product.

Construction Requirement Sequential Flashing Warning Lights are to be used for night time lane closures.

These lights shall flash sequentially beginning with the first light and continuing until the final light.

The Sequential Flashing Warning Lights shall automatically flash in sequence when placed on the drums that form the merging taper.

The number of lights used in the drum taper shall equal one half the number of drums used in the taper.

Drums are the only channelizing device allowed to mount sequential flashing warning lights.

The Sequential Flashing Warning Lights shall be weather independent and visual obstructions shall not interfere with the operation of the lights.

The Sequential Flashing Warning Lights shall automatically sequence when placed in line in an open area with a distance between lights of 10 to 100 feet. A 10 foot stagger in the line of lights shall have no adverse effect on the operation of the lights.

If one light fails, the flashing sequence shall continue. If more than 2 lights fail, all of the lights are to be automatically turned to the "off" mode. Non-sequential flashing is prohibited.

When lane closures are not in effect, the Sequential Flashing Warning Lights shall be deactivated.

Method of Measurement Sequential Flashing Warning Lights will be measured as the maximum number of sequential flashing warning lights satisfactorily installed and properly functioning at any one time during the life of the project.

This includes all materials and labor to install, maintain and remove all Sequential Flashing Warning Lights.

Pay Item		Pay Unit
652.46	Sequential Flashing Warning Lights	Each

SPECIAL PROVISION
SECTION 652
MAINTENANCE OF TRAFFIC

TEMPORARY PORTABLE RUMBLE STRIPS

Description This special provision describes providing, relocating, maintaining, and removing temporary portable rumble strips.

Materials Furnish a portable rumble strip system. The Contractor shall submit for approval, literature and all necessary certifications to the Department prior to procurement of the product.

Construction Requirement

Placement:

Provide rumble strips where the plans show or as directed by the Resident as follows:

1. Prior to placing rumble strips, clean the roadway of sand and other materials that may cause slippage.
2. Place one end of the rumble strips 6 inches from the roadway centerline. Extend the strips perpendicular to the direction of travel. Ensure strips lay flat on the roadway surface.
3. Only one group of rumble strips, placed before the first work zone, is required per direction of travel for multiple work zones spaced 1 mile or less apart. Work zones spaced greater than 1 mile apart require a separate group of rumble strips. Each lane shall use one group of temporary rumble strips.
4. Temporary Portable Rumble Strips shall be placed concurrently with placement of sign packages.

Maintenance

Maintain rumble strips as follows:

1. If rumble strips slide, become out of alignment, or are no longer in the wheel path of approaching vehicles during the work period, thoroughly clean both sides of the rumble strips and reset on a clean roadway.
2. Repair or replace damaged rumble strips immediately.

Method of Measurement Temporary Portable Rumble Strips will be measured as one group, per lane. A group shall be considered 3 full lane width of rumble strips. Additional warning signs indicating “Caution Rumble Strip” will be measured separately under Item 652.35 Construction Signs.

Basis of Payment The accepted quantity of temporary portable rumble strips will be paid for at the contract unit price per group. Payment for additional signs will be made under Item 652.35 Construction Signs. Payment is full compensation for providing, relocating, maintaining or replacing, and removing temporary portable rumble strips.

<u>Pay Item</u>	<u>Pay Unit</u>
652.47 Temporary Portable Rumble Strip	Group

STANDARD DETAIL UPDATES

Standard Details and Standard Detail updates are available at:
<http://maine.gov/mdot/contractors/publications/standarddetail/>

<u>Detail #</u>	<u>Description</u>	<u>Revision Date</u>
501(02)	Pipe Pile Splice	3/05/2015
501(03)	H – Pile Splice	3/05/2015
504(07)	Diaphragm & Crossframe Notes	10/13/2015
505(01)	Shear Connectors	10/24/2016
507(13)	Steel Bridge Railing	6/03/2015
507(14)	Steel Bridge Railing	6/03/2015
507(31)	Barrier – Mounted Steel Bridge	8/06/2015
526(02)	Temporary Concrete Barrier	8/06/2015
626(07)	Conduit Trench for Traffic Signals, Highway Signing and Lighting	5/17/2018
652(06)	Construction Signs	10/24/2016
652(12)	Construction Traffic Control	10/24/2016
802(05)	Roadway Culvert End Slope Treatment	1/03/2017
504(10)	Drip Bar Details	9/06/2017
609(9)	Concrete Slipform Curb	5/06/2018

SUPPLEMENTAL SPECIFICATIONS
(Corrections, Additions, & Revisions to Standard Specifications - November 2014)

SECTION 101
CONTRACT INTERPRETATION

101.1 Abbreviations Revise the definition of AWWA to “**American Wood Protection Association**”.

101.2 Definitions

Page 1-5 – Remove the definition of Bridge in its entirety and replace with:

“Bridge A structure that is erected over a depression or an obstruction, such as water, a highway or a railway, and has an opening measured along the centerline of the Roadway of more than 20 feet between: The faces of abutments; spring line of arches; extreme ends of openings of box culverts, pipes or pipe arches; or the extreme ends of openings for multiple box culverts, pipes or pipe arches.”

Page 1-12 – Remove the definition of Large Culvert in its entirety and replace with:

“Large Culvert Any structure not defined as a Culvert or Bridge that provides a drainage or non-drainage opening under the Roadway or Approaches to the Roadway, with an opening that is 5 feet but less than 10 feet.”

Remove the definition of Minor Span in its entirety and replace with:

“Minor Span Same definition as Bridge, except having an opening of between 10 feet and 20 feet, inclusive.”

SECTION 103
AWARD AND CONTRACTING

Amend this Section by adding the following:

“103.1a Tie Bids - In the case where two responsive bids from responsible bidders are equal monetarily, the Department shall determine the apparent low bidder by flipping a coin. The coin shall have sides clearly marked as heads and tails. The contractor whose first letter in their official company name that comes first in the alphabet shall be heads.

If there are three bids, each bidder will flip the coin and the bidder with the odd toss will be the winner. (i.e. if the results are two heads and a tails, the bidder who had tails is the winner). For a three way tie, bidders may flip their own coin or have the Contracts Engineer flip for them.

The coin flip will occur at the next bid opening by the Contracts and Specifications Engineer or a designee. The tied bidders may attend the coin flip in person or watch on the internet as they choose.”

In 103.3.2 Notice of Determination Revise this section by removing sections A – M and replacing with the following A - K:

(A) Default(s) or termination(s) on past or current Contracts.

**(B) Failure on past or current Contracts to pay or settle all bills for labor, Materials or services;
to comply with directives of the Department, to fulfill warranty obligations, or to provide Closeout Documentation.**

(C) "Below Standard" performance as determined from the Department's Contractor's Performance Rating process.

(D) Insufficient bonding capability or Inability of the Contractor to obtain or retain performance or Payment Bonds meeting MDOT requirements, or a pattern of unsupported Claims.

(E) Failure to accept an Award of a Contract made by the Department.

(F) Failure to provide information requested by the Department in a timely manner.

(G) Debarment, suspension or a denial of prequalification or 'award of contract' by any federal, State, or local governmental procurement agency or the Contractor's Agreement to refrain from Bidding as part of the settlement with any such agencies or any of the reasons contained in Section 102.02 of the "Rules Regarding Debarment of Contractors", Maine Department of Transportation Register 17-229, Chapter 102 (October 2, 1985).

(H) Failure to demonstrate ability to do work to the satisfaction and at the sole discretion of the Department.

(I) Number of personnel working directly for the Contractor with applicable knowledge and experience is significantly below industry standards.

(J) Safety Record, Environmental Record, Civil Rights or Equal Opportunity Record significantly below industry standards.

(K) Serious misconduct that the Department reasonably determines will substantially and adversely affect the cost, quality or timeliness of Work, or the safety of Workers or the public, any deceptive, evasive or fraudulent statements or omissions contained in the Application, made or omitted at any interview or hearing, or otherwise made to or omitted from the Department; or any other substantial deficiencies in experience or conduct that are clearly below industry standards and that clearly demonstrate in the sole discretion of the Department, that the Contractor is "Not Qualified".

SECTION 104 **GENERAL RIGHTS AND RESPONSIBILITIES**

This Section shall be amended by adding the following two sub-sections:

104.3.8.1 Electronic Payroll Submission On federally funded projects the prime contractor, all subcontractors, and lower-tier subcontractors will submit their certified payrolls electronically utilizing the Elations system. There is no charge to the contracting community for the use of this service. The submission of paper payrolls will not be allowed or accepted. Additional information can be found at <http://www.maine.gov/mdot/contractors/> under the “Bidder Info” go to “Electronic Payroll System.”

104.3.8.2 Payment Tracking On federally funded projects the prime contractor and all subcontractors and lower-tier subcontractors will track and confirm the delivery and receipt of all payments through the Elation System

104.4.10 Coordination of Road Closure / Bridge Closure / Bridge Width Restrictions

Revise the last sentence by adding a period after ‘Resident’; remove the “and” after Resident; and adding “**not covered by Pay Items**” between ‘costs’ and ‘will’. So that the last paragraph reads “**All Newspaper notices, radio announcements and any notifications will be subject to the approval of the Resident. All costs not covered by Pay Items will be considered incidental to the Contract.**”.

104.5.5 Prompt Payment of Subcontractors Add the following paragraph to this subsection:

C. Payment Tracking Federal Projects On federally funded projects, the prime contractor, subcontractors and lower-tier subcontractors will track and confirm the delivery and receipt of all payments through the Elation System. They will be responsible for entering all payments to all sub and lower tier contractors. MaineDOT will run a query monthly to ensure that contractors are complying and generate an e-mail to contractors who have not responded to confirm receipt of MaineDOT payment or contractor payment to lower tier subcontractors.

SECTION 105 **GENERAL SCOPE OF WORK**

105.2.5 Compliance with Health and Safety Laws Remove the second paragraph of this subsection in its entirety and replace with:

“For related provisions, see Sections 105.2.3 – Project Specific Emergency Planning, 105.3 – Traffic Control and Management and 105.4 – Maintenance of work.”

105.4.5 Special Detours Remove this subsection in its entirety and replace with:

“105.4.5 Maintenance of Existing Structures When a new Bridge or Minor Span is being installed on a new alignment and the existing structure is to remain in service, the Department will maintain the existing structure and the portions of the roadway required for maintaining traffic until such time that the new structure is opened to traffic and the existing structure is taken out of service. A similar situation exists when a new Bridge or Minor Span is being installed on the same alignment as the existing structure, requiring a temporary detour to be installed by the Contractor per Section 510, Special Detours, prior to removal of the existing structure. In this case, the Department will maintain the existing structure and the portions of the existing roadway required for maintaining traffic until such time that either the temporary detour is opened to traffic or the Contractor begins any work on the existing structure, including, but not limited to, repairs, modifications, moving, demolition or removal. In either case, once the new structure or temporary detour is opened to traffic, or the Contractor begins any work on the existing structure, the Contractor shall be solely responsible for all maintenance of the existing structure and the portions of the existing approaches that lie outside the new roadway or the temporary detour, respectively. This specification is not intended to supersede Standard Specification Section 104.3.11, Responsibility for Property of Others.”

105.6.2.4 Department Verification Add the following to the end of the first sentence:
“or other approved method, such as reference staking, to allow the Department to independently verify the accuracy of the work, as approved by the Department.”

SECTION 106 **QUALITY**

106.3.4 Storage Revise this Section by adding the following sentence after the first sentence:
“Materials shall not be stored under or in close proximity to Highway Structures unless the Contractor receives written permission from the Resident.”

106.4.1 General - In the first sentence, remove “When required by Special Provision,” and replace with **“When required elsewhere in the Contract,”**

Revise Subsection C by replacing the last sentence with the following:

Approval of both standard and project specific QCPs shall be as outlined in paragraph B above, with the exception that the initial 14 day review period for standard plans will begin on March 1, and that the supplemental project specific QCP for the project shall be submitted a minimum of 14 days prior to any related work being performed with an initial review period of 7 days.

SECTION 107
TIME

107.7.2 SCHEDULE OF LIQUIDATED DAMAGES

Revise this section by removing the numbers in the chart and replace with the following:

Original Contract Amount		Per Diem Amount of Liquidated Damages	
From More Than	To and Including	Calendar Day	
\$ 0	to	\$ 100,000.00	\$250.00
\$ 100,000.00	to	\$ 250,000.00	\$500.00
\$ 250,000.00	to	\$ 500,000.00	\$650.00
\$ 500,000.00	to	\$1,000,000.00	\$800.00
\$1,000,000.00	to	\$2,000,000.00	\$1,000.00
\$2,000,000.00	to	\$4,000,000.00	\$1,200.00
\$4,000,000.00	and	More	\$2,100.00

SECTION 108
PAYMENT

108.3 Retainage - Remove the paragraph beginning with “ The Contractor may withdraw...” in its entirety.

108.4.1 Price Adjustment for Hot Mix Asphalt:

Remove this section in its entirety and replace with the following

For all contracts with hot mix asphalt in excess of 500 tons total, a price adjustment for performance graded binder will be made for the following pay items:

Item 403.102	Hot Mix Asphalt – Special Areas
Item 403.206	Hot Mix Asphalt - 25 mm
Item 403.207	Hot Mix Asphalt - 19 mm
Item 403.2071	Hot Mix Asphalt - 19 mm (Polymer Modified)
Item 403.2072	Hot Mix Asphalt - 19 mm (Asphalt Rich Base)
Item 403.208	Hot Mix Asphalt - 12.5 mm
Item 403.2081	Hot Mix Asphalt - 12.5 mm (Polymer Modified)
Item 403.209	Hot Mix Asphalt - 9.5 mm (sidewalks, drives, & incidentals)
Item 403.210	Hot Mix Asphalt - 9.5 mm
Item 403.2101	Hot Mix Asphalt - 9.5 mm (Polymer Modified)
Item 403.2102	Hot Mix Asphalt - 9.5 mm (Asphalt Rich Base)

Item 403.2104	Hot Mix Asphalt - 9.5 mm (Thin Lift Surface Treatment)
Item 403.21041	Hot Mix Asphalt - 9.5 mm (Polymer Modified Thin Lift Surface Treatment)
Item 403.211	Hot Mix Asphalt – Shim
Item 403.2111	Hot Mix Asphalt – Shim (Polymer Modified)
Item 403.212	Hot Mix Asphalt - 4.75 mm (Shim)
Item 403.213	Hot Mix Asphalt - 12.5 mm (base and intermediate course)
Item 403.2131	Hot Mix Asphalt - 12.5 mm (base and intermediate course Polymer Modified)
Item 403.2132	Hot Mix Asphalt - 12.5 mm (Asphalt Rich Base and intermediate course)
Item 403.214	Hot Mix Asphalt - 4.75 mm (Surface)
Item 403.235	Hot Mix Asphalt (High Performance Rubberized HMA)
Item 403.301	Hot Mix Asphalt (Asphalt Rubber Gap-Graded)
Item 404.70	Colored Hot Mix Asphalt – 9.5mm (Surface)
Item 404.72	Colored Hot Mix Asphalt – 9.5mm (Islands, sidewalks, & incidentals)
Item 461.13	Light Capital Pavement
Item 461.210	9.5 mm HMA - Paver Placed Surface
Item 462.30	Ultra-Thin Bonded Wearing Course
Item 462.301	Polymer Modified Ultra-Thin Bonded Wearing Course

Price adjustments will be based on the variance in costs for the performance graded binder component of hot mix asphalt. They will be determined as follows:

The quantity of hot mix asphalt for each pay item will be multiplied by the performance graded binder percentages given in the table below times the difference in price between the base price and the period price of asphalt cement. Adjustments will be made upward or downward, as prices increase or decrease.

Item 403.102	-6.2%
Item 403.206	-4.8%
Item 403.207	-5.2%
Item 403.2071	-5.2%
Item 403.2072	-5.8%
Item 403.208	-5.6%
Item 403.2081	-5.6%
Item 403.209	-6.2%
Item 403.210	-6.2%
Item 403.2101	-6.2%
Item 403.2102	-6.8%
Item 403.2104	-6.2%
Item 403.21041	-6.2%
Item 403.211	-6.2%
Item 403.2111	-6.2%
Item 403.212	-6.8%
Item 403.213	-5.6%
Item 403.2131	-5.6%

Item 403.2132–6.2%
Item 403.214–6.8%
Item 403.235–5.5%
Item 403.301–6.2%
Item 404.70–6.2%
Item 404.72–6.2%
Item 461.13–6.5%
Item 461.210 – 6.4%
Item 462.30–0.0021 tons/SY
Item 462.301–0.0021 tons/SY

Hot Mix Asphalt: The quantity of hot mix asphalt will be determined from the quantity shown on the progress estimate for each pay period.

Base Price: The base price of performance graded binder to be used is the price per standard ton current with the bid opening date. This price is determined by using the average New England Selling Price (Excluding the Connecticut market area), as listed in the Asphalt Weekly Monitor.

Period Price: The period price of performance graded binder will be determined by the Department by using the average New England Selling Price (Excluding the Connecticut market area), listed in the Asphalt Weekly Monitor current with the paving date. The maximum Period Price for paving after the adjusted Contract Completion Date will be the Period Price on the adjusted Contract Completion Date.

SECTION 109 **CHANGES**

109.5.1 Definitions - Types of Delays

Delete Paragraph 'A' in its entirety and replace with:

"A. Excusable Delay Except as expressly provided otherwise by this Contract, an "Excusable Delay" is a Delay to the Critical Path that is directly and solely caused by (1) a weather related Event of such an unusually severe nature that a Federal Emergency Disaster is declared. The Contractor will only be entitled to an adjustment of time if the Project falls within the geographic boundaries prescribed under the disaster declaration. or (2) a flooding event at the effected location of the Project that results in a Q25 headwater elevation, or greater, but less than a Q50 headwater elevation. Theoretical headwater elevations will be determined by the Department; actual headwater elevations will be determined by the Contractor and verified by the Department or (3) An Uncontrollable Event."

SECTION 110 INDEMNIFICATION, BONDING AND INSURANCE

110.3.9 Administrative & General Provisions

B. Defense of Claims Amend this section by adding the following sentence to the end:
“The Contractor’s insurer shall name the Department of Transportation as a released party (Releasee)” on any release or settlement agreement for settled claims.”

APPENDIX A TO DIVISION 100

Remove Section D in its entirety as this is now covered in Section 105.10 EQUAL OPPORTUNITY AND CIVIL RIGHTS.

SECTION 203 EXCAVATION AND EMBANKMENT

203.02 Materials

At the bottom of page 2-12, add as the first item in the list:

Crushed Stone, ¾ inch 703.13

203.042 Rock Excavation and Blasting

On page 2-16, add the word “**No**” to the third sentence in Section 5 Submittals, Subsection V, 1 so that it reads:

“No blasting products will be allowed on the job site if the date codes are missing.”

203.09 Preparation of Embankment Area Revise the first sentence of the second paragraph so that it reads:

“When fill material is placed against existing slopes or previously placed fill, the interface shall be continuously benched by excavating steps of sufficient width to permit operations of placing and compacting the additional material.”

SECTION 304 AGGREGATE BASE AND SUBBASE COURSE

304.02 – Aggregate Add the following sentence before the sentence starting with “When designated on the plans...”: **“Aggregate Base Course – Type C will be capped with 2” of millings or Untreated Aggregate Surface Course – Type B. Payment for this material will be made under 304.16”**

Revise the sentence beginning “When designated on the Plans, Type E...” by removing “When designated on the Plans,” so it reads **“Type E subbase may be used 9 inches below and lower beneath the pavement.”**

SECTION 307
FULL DEPTH RECYCLED PAVEMENT

Remove this Section in its entirety and replace with:

SECTION 307
FULL DEPTH RECYCLING
(UNTREATED OR TREATED WITH EMULSIFIED ASPHALT STABILIZER)

307.01 Description This work shall consist of pulverizing a portion of the existing roadway structure into a homogenous mass, adding an emulsified asphalt stabilizer (if required) to the depth of the pulverized material specified in the contract, placing and compacting this material to the lines, grades, and dimensions shown on the plans or established by the Resident.

MATERIALS

307.02 Pulverized Material Pulverized material shall consist of the existing asphalt pavement layers and one inch or more as specified of the underlying gravel, pulverized and blended into a homogenous mass. Pulverized material will be processed to 100% passing a 2 inch square mesh sieve.

307.021 New Aggregate and Additional Recycled Material New aggregate, if required by the contract, shall meet the requirements of Subsection 703.10 - Aggregate for Untreated Surface Course and Leveling Course, Type A. Aggregate Subbase Course Gravel Type D processed to 100 percent passing a 2 inch square mesh sieve and meeting the requirements of 703.06 – Aggregate for Base and Subbase may be used in areas requiring depths greater than 2 inches. New aggregate, will be measured and paid for under the appropriate item.

Recycled material, if required, shall consist of salvaged asphalt material from the project or from off-site stockpiles that has been processed before use to 100 percent passing a 2 inch square mesh sieve. Recycled material shall be conditionally accepted at the source by the Resident. It shall be free of winter sand, granular fill, construction debris, or other materials not generally considered asphalt pavement.

Recycled material generated and salvaged from the project shall be used within the roadway limits to the extent it is available as described in 307.09. No additional payment will be made for material salvaged from the project.

Recycled material supplied from off-site stockpiles shall be paid for as described in the contract, or by contract modification.

307.022 Emulsified Asphalt Stabilizer. If required, the emulsified asphalt stabilizer shall be grade MS-2, MS-4, SS-1, or CSS-1 meeting the requirements of Subsection 702.04 Emulsified Asphalt.

307.023 Water Water shall be clean and free from deleterious concentrations of acids, alkalis, salts or other organic or chemical substances.

307.024 Portland Cement If required, Portland Cement shall be Type I or II meeting the requirements of AASHTO M85.

307.025 Hydrated Lime If required, Hydrated Lime shall meet the requirements of AASHTO M216.

EQUIPMENT

307.03 Pulverizer The pulverizer shall be a self-propelled machine, specifically manufactured for full-depth recycling work and capable of reducing the required existing materials to a size that will pass a 2 inch square mesh sieve. The machine shall be equipped with standard automatic depth controls and must maintain a consistent cutting depth and width. The machine also shall be equipped with a gauge to show depth of material being processed.

307.04 Liquid Mixer Unit or Distributor. If treatment of the recycled layer with emulsified asphalt is required by the contract, a liquid mixing unit or distributor shall be used to introduce the emulsified asphalt stabilizer into the pulverized material. The mixing unit shall contain a liquid distribution and mixing system which has been specifically manufactured for full-depth recycling work, capable of mixing the pulverized material with an evenly metered distribution of emulsified asphalt into a homogeneous mixture, to the depth and width required.

The mixing unit shall be designed, equipped, maintained, and operated so that emulsified asphalt stabilizer at constant temperature may be applied uniformly on variable widths of pulverized material up to 6 feet at readily determined and controlled rates from 0.01 to 1.06 gal/yd² with uniform pressure and with an allowable variation from any specified rate not to exceed 0.01 gal/ yd². Mixing units shall include a tachometer, pressure gages, and accurate volume measuring devices or a calibrated tank and a thermometer for measuring temperatures of tank contents.

307.041 Cement or Lime Spreader If required by the contract, spreading of the Portland Cement or Hydrated Lime shall be done with a spreader truck designed to spread dry particulate (such as Portland Cement or Lime) or other approved means to insure a uniform distribution across the roadway and minimize fugitive dust. Pneumatic application, including through a slotted pipe, will not be permitted. Other systems that have been developed include fog systems, vacuum systems, etc. Slurry applications may also be accepted. The Department reserves the right to accept or reject the method of spreading cement. The Contractor shall provide a method for verifying that the correct amount of cement is being applied.

307.05 Placement Equipment Placement of the Full Depth recycled material to the required slope and grade shall be done with an approved highway grader or by another method approved by the Resident.

307.06 Rollers The full depth recycled material shall be rolled with a vibratory pad foot roller, a vibratory steel drum soil compactor and a pneumatic tire roller. The pad foot roller drum shall have a minimum of 112 tamping feet 3 inches in height, a minimum contact area per foot of 17 inch², and a minimum width of 84 inches. The vibratory steel drum roller shall have a minimum 84 inch width single drum. The pneumatic tire roller shall meet the requirements of Section 401.10 and the minimum allowable tire pressure shall be 85 psi.

MIX DESIGN

If treatment of the recycled layer with emulsified asphalt is required by the contract, the Department will supply a mix design for the emulsified asphalt stabilized material based on test results from pavement and soil analysis taken to the design depth. The Department will provide the following information prior to construction:

1. Percent of emulsified asphalt to be used.
2. Quantity of lime or cement to be added.
3. Optimum moisture content for proper compaction.
4. Additional aggregate (if required).

After a test strip has been completed or as the work progresses, it may be necessary for the Resident to make necessary adjustments to the mix design. Changes to compensation will be in accordance with the Mix Design Special Provision.

CONSTRUCTION REQUIREMENTS

307.06 Pulverizing The entire depth of existing pavement shall be pulverized together with 1 inch or more of the underlying gravel into a homogenous mass. All pulverizing shall be done with equipment that will provide a homogenous mass of pulverized material, processed in-place, which will pass a 2 inch square mesh sieve.

307.07 Weather Limitations Full depth recycled work shall be performed when;

- A. Recycling operations will be allowed between May 15th and September 15th inclusive in Zone 1 - Areas north of US Route 2 from Gilead to Bangor and north of Route 9 from Bangor to Calais.
- B. The atmospheric temperature, as determined by an approved thermometer placed in the shade at the recycling location, is 50°F and rising.
- C. When there is no standing water on the surface.

- D. During generally dry conditions, or when weather conditions are such that proper pulverizing, mixing, grading, finishing and curing can be obtained using proper procedures, and when compaction can be accomplished as determined by the Resident.**
- E. When the surface is not frozen and when overnight temperatures are expected to be above 32°F.**
- F. Wind conditions are such that the spreading of lime or cement on the roadway ahead of the recycling machine will not adversely affect the operation.**

307.08 Surface Tolerance The complete surface of the Full Depth Recycled course shall be shaped and maintained to a tolerance, above or below the required cross sectional shape, of $\frac{3}{8}$ inch.

307.09 Full Depth Recycling Procedure New aggregate or recycled material meeting the requirements of Section 307.021 - New Aggregate and Additional Recycled Material, shall be added as necessary to restore cross-slope and/or grade before pulverizing. Locations will be shown on the plans or described in the construction notes. The Resident may add other locations while construction of the project is in progress. The Contractor will use recycled material to the extent it is available, in lieu of new aggregate. The material shall then be pulverized, processed, and blended into a homogeneous mass passing a 2 inch square mesh sieve. Material found not pulverized down to a 2 inch size will be required to be reprocessed by the recycler with successive passes until approved by the Resident.

Should the Contractor be required to add new aggregate or recycled material to restore cross-slope and/or grade after the initial pulverizing process, those areas will require re-processing to blend into a homogenous mass passing a 2 in square mesh sieve.

Sufficient water shall be added during the recycling process to maintain optimum moisture for compaction.

The resultant material from the initial pulverizing processes shall be graded and compacted to the cross-slope and profile shown on the plans or as directed by the Resident. The Contractor will also be responsible for re-establishing the existing profile grade. The completed surface of the full depth recycled course shall be shaped and maintained to a tolerance, above or below the required cross sectional shape, of $\frac{3}{8}$ inch. Areas not meeting this tolerance will be repaired as described in Section 307.091. The initial pulverizing process density requirements will be the same as Section 307.101 unless otherwise directed by the Resident.

Additives, if required, shall be introduced following completion of the initial pulverizing and blending process. Emulsified asphalt stabilizer shall be incorporated into the top of the processed material as specified in section 307.04 to the depth specified in the contract by use of the liquid mixer unit or a distributor, at the rate specified in the mix design. The emulsified asphalt shall then be uniformly blended into a homogeneous mass until an apparent uniform distribution has occurred.

The rate of application may be adjusted as necessary by the Resident. Cement or lime shall be introduced as described in section 307.041. The resultant material shall be graded and compacted to the cross-slope and profile shown on the plans or as directed by the Resident. The Contractor will also be responsible for re-establishing the existing profile grade.

After final compaction, the roadway surface shall be treated with a light application of water, and rolled with pneumatic-tired rollers to create a close-knit texture. The finished layer shall be free from:

- A. Surface laminations.
- B. Segregation of fine and coarse aggregate.
- C. Corrugations, centerline differential, potholes, or any other defects that may adversely affect the performance of the layer, or any layers to be placed upon it.

The Contractor shall protect and maintain the recycled layer until a lift of pavement is applied. Any damage or defects in the layer shall be repaired immediately. An even and uniform surface shall be maintained. The recycled surface shall be swept prior to hot mix asphalt overlay placement.

307.091 Repairs Repairs and maintenance of the recycled layers, resulting from damage caused by traffic, weather or environmental conditions, or resulting from damage caused by the Contractor's operations or equipment, shall be completed at no additional cost to the Department.

For recycled layers stabilized with emulsified asphalt, low areas will be repaired using a hot mix asphalt shim. Areas up to 1 inch high can be repaired by milling or shimming with hot mix asphalt. Areas greater than 1 inch high will be repaired using a hot mix asphalt shim. All repair work will be done with the Resident's approval at the Contractor's expense.

TESTING REQUIREMENTS

307.10 Quality Control The Contractor shall operate in accordance with the approved Quality Control Plan (QCP) to assure a product meeting the contract requirements. The QCP shall meet the requirements of Section 106.4 - Quality Control and this Section. The Contractor shall not begin recycling operations until the Department approves the QCP in writing. Prior to performing any recycling process, the Department and the Contractor shall hold a Pre-recycle conference to discuss the recycling schedule, type and amount of equipment to be used, sequence of operations, and traffic control. A copy of the QC random numbers to be used on the project shall be provided to the Resident. All field supervisors including the responsible onsite recycling process supervisor shall attend this meeting.

The QCP shall address any items that affect the quality of the Recycling Process including, but not limited to, the following:

- A. Sources for all materials, including New Aggregate and Additional Recycled Material.
- B. Make and type of rollers including weight, weight per inch of steel wheels, and average contact pressure for pneumatic tired rollers.
- C. Testing Plan.
- D. Recycling operations including recycling speed, methods to ensure that segregation is minimized, grading and compacting operations.
- E. Methods for protecting the finished product from damage and procedures for any necessary corrective action.
- F. Method of grade checks.
- G. Examples of Quality Control forms.
- H. Name, responsibilities, and qualifications of the Responsible onsite Recycling Supervisor experienced and knowledgeable with the process.
- I. A note that all testing will be done in accordance with AASHTO and MDOT/ACM procedures.

The Project Superintendent shall be named in the QCP, and the responsibilities for successful implementation of the QCP shall be outlined.

The Contractor shall sample, test, and evaluate the full depth reclamation process in accordance with the following minimum frequencies:

MINIMUM QUALITY CONTROL FREQUENCIES

Test or Action	Frequency	Test Method
Density	1 per 1000 feet / lane	AASHTO T 310
Air Temperature	4 per day at even intervals	
Surface Temperature	At the beginning and end of each days operation	
Yield of all materials (Daily yield, yield since last test, and total project yield.)	1 per 1000 ft/lane	

The Department may view any QC test and request a QC test at any time. The Contractor shall submit all QC test reports and summaries in writing, signed by the appropriate technician, to the Department's onsite representative by 1:00 P.M. on the next working day, except when otherwise noted in the QCP due to local restrictions. The Contractor shall make all test results, including randomly sampled densities, available to the Department onsite.

The Contractor shall cease recycling operations whenever one of the following occurs:

- A. The Contractor fails to follow the approved QCP.**
- B. The Contractor fails to achieve 98 percent density after corrective action has been taken.**
- C. The finished product is visually defective, as determined by the Resident.**
- D. The computed yield differs from the mix design by 10 percent or more.**

Recycling operations shall not resume until the Department approves the corrective action to be taken.

307.101 Test Strip The contractor shall assemble all items of equipment for the recycling operation on the first day of the recycling work. The Contractor shall construct a test strip for the project at a location approved by the Resident. The Responsible onsite Recycling Supervisor will work with Department personnel to determine the suitability of the mixed material, moisture control within the mixed material, and compaction and surface finish. The test strip section is required to:

- A. Demonstrate that the equipment and processes can produce recycled layers to meet the requirements specified in these special provisions.**
- B. Determine the effect on the gradation of the recycled material by varying the forward speed of the recycling machine and the rotation rate of the milling drum.**
- C. Determine the optimum moisture necessary to achieve proper compaction of the recycled layer.**
- D. Determine the sequence and manner of rolling necessary to obtain the compaction requirements and establish a target density. The Contractor and the Department will both conduct testing with their respective gauges at this time.**

The test strip shall be at least 300 feet in length of a full lane-width (or a half-road width). Full recycling production will not start until a passing test strip has been accomplished. If a test strip fails to meet the requirements of this specification, the Contractor will be required to repair or replace the test strip to the satisfaction of the Resident. Any repairs, replacement, or duplication of the test strip will be at the Contractor's expense.

After the test strip has been pulverized, and the roadway brought to proper shape, the Contractor shall add water until it is determined that optimum moisture has been obtained. The test strip shall then be rolled using the specified compaction equipment as directed until the density readings show an increase in dry density of less than 1 pcf for the final four roller passes of each roller. The Contractor and Department will each determine a target density using their respective gauges by performing several additional density tests and averaging them. The average of these tests will be used as the target density of the recycled material for QC and Acceptance purposes.

Following completion of the test strip, compaction of the material shall continue until a density of not less than 98 percent of the test strip target density has been achieved for the full width and depth of the layer. During the construction and compaction of the Full Depth Recycled base, should three consecutive Acceptance test results for density fail to meet a minimum of 95 percent of the target density, or exceed 102 percent of target density, a new test strip shall be constructed.

ACCEPTANCE TEST FREQUENCY

Property	Frequency	Test Method
In-place Density	1 per 2000 ft / lane	AASHTO T 310

307.102 Curing. No new pavement shall be placed on the full depth recycled pavement until curing has reduced the moisture content to 1 percent or less by total weight of the mixture, or a curing period of 4 days has elapsed, whichever comes first.

307.11 Method of Measurement Full Depth Recycled Pavement (Untreated or Treated with Emulsified Asphalt Stabilizer) will be measured by the square yard.

307.12 Basis of Payment The accepted quantity of Full Depth Recycled Asphalt Pavement (Untreated or Treated with Emulsified Asphalt Stabilizer) will be paid for at the contract unit price per square yard, complete in-place which price will be full compensation for furnishing all equipment, materials and labor for pulverizing, blending, placing, grading, compacting, and for all incidentals necessary to complete the work.

The addition of materials to restore profile grade and/or cross-slope in areas shown on the plans or described in the construction notes will be paid separately under designated pay items within the contract. No additional payment will be made for materials salvaged from the project.

Payments will be made under:

<u>Pay Item</u>	<u>Pay Unit</u>
307.331 Full Depth Recycled Pavement (Untreated)	Square Yard
307.332 Full Depth Recycled Pavement (with Emulsified Asphalt Stabilizer) 5 in. depth	Square Yard
307.333 Full Depth Recycled Pavement (with Emulsified Asphalt Stabilizer) 6 in. depth	Square Yard

SECTION 411
UNTREATED AGGREGATE SURFACE COURSE

411.02 – Aggregate Add the following to the end of the first sentence: “- **Type A**”

SECTION 501
FOUNDATION PILES

501.05 – Method of Measurement

b. Piles Furnished – After the second sentence, add the sentence “**Measurement will not include any pile tips**”.

c. Piles in Place – Add the sentence to the end of the second paragraph, “**Measurement will include the pile tips**”.

d. Pile Tips – Add the words “**on the Pile**” to the end of the sentence.

SECTION 502
STRUCTURAL CONCRETE

502.05 Composition and Proportioning

Replace Table 1 with

TABLE 1

Concrete CLASS	Minimum Compressive Strength (PSI)	Permeability as indicated by Surface Resistivity (KOhm-cm)	Entrained Air (%)		Notes
			LSL	USL	
S	3,000	LSL N/A	LSL N/A	USL N/A	4,5
A	4,000	14	6.0	9.0	1,4,5
P	-----	-----	5.5	7.5	1,2,3,4
LP	5,000	17	6.0	9.0	1,4,5
Fill	3,000	N/A	6.0	9.0	4,5

In the list of information submitted by the contractor for a mix design:

Item J Replace “Target Coulomb Value.” with “Target KOhm-cm Value.”

Note #1 - Remove, “...Standard Specification Section 711.05, Protective Coating for Concrete Surfaces, and per the manufacturer’s recommendations, at no additional cost to the Department.” and replace with, “...Standard Specification Section 515, Protective Coating for Concrete Surfaces, at no additional cost to the Department.”

502.1703 Acceptance Methods A and B

In the paragraph that starts with “The Department will take Acceptance...” Remove the word chloride from chloride permeability in the last sentence.

Replace the paragraph starting with “Rapid Chloride Permeability specimens...” With the following:
“Surface Resistivity specimens will be tested by the Department in accordance with AASHTO TP-95 at an age \geq 56 days. Four 4 inch x 8 inch cylinders will be cast per subplot placed. The average of three concrete specimens per subplot will constitute a test result and this average will be used to determine the permeability for pay adjustment computations.”

502.1706 Acceptance Method C

Remove in its entirety and Replace with:

502.1706 Acceptance Method C The Department will determine the acceptability of the concrete through Acceptance testing. Acceptance tests will include compressive strength, air content and permeability. Method C concrete not meeting the requirements listed in Table 1 shall be removed and replaced at no cost to the Department. At the Department’s sole discretion, material not meeting requirements may be left in place and paid for at a reduced price as described in Section 502.195.

502.1707 Resolution of Disputed Acceptance Test Results
Section B

Remove “Rapid Chloride” from the section heading.
In paragraph 4 replace T-277 with TP-95

502.192 Pay Adjustment for Chloride Permeability

Remove “Chloride” from the heading and from the first sentence.

Replace the sentence that starts with “values greater than...” and replace with “values less than 10 KOhms-cm for Class A concrete or 11 KOhms-cm for Class LP concrete shall be subject to rejection and replacement, at no additional cost to the Department.”

502.194 Pay Adjustments for Compressive Strength, Chloride Permeability and Air Content, Methods A and B

Remove the word “Chloride” from the section heading and from the equation for CPF.

502.195 Pay Adjustment Method C

In Table 6: Method C Pay Reductions (page 5-53)
Under “Entrained Air” for “Class Fill”, in the first line,
change from “< 4.0 (Removal)” to “< 4.5 (Removal)”

In Table 6: Method C PAY REDUCTIONS, revise the Chloride Permeability section by removing it
in its entirety and replacing it with:

Surface Resistivity {Permeability in Kohm-cms and Pay Reduction per CY}			
15-16 (\$50)	13 (\$25)	N/A	N/A
13-14 (\$75)	12(\$50)	N/A	N/A
12 (\$100)	11 (\$75)	N/A	N/A
11 (\$125)	10 (\$100)	N/A	N/A
< 11 (Removal)	< 10 (Removal)	N/A	N/A

SECTION 503
REINFORCING STEEL

503.06 Placing and Fastening Revise this Subsection by removing, in its entirety, the paragraph
which begins, “Stainless steel reinforcement shall not be tied to any other type of
reinforcement.....”

SECTION 504
STRUCTURAL STEEL

504.26 Welding Remove the second paragraph beginning with “The range of heat...” in its
entirety.

504.29 Welding ASTM A 709 HPS 70W Steel. Remove the third paragraph beginning with “Make
Weld runoff tabs...” in its entirety.

SECTION 510
SPECIAL DETOURS

510.032 Geometric and Approach Design a. Horizontal alignment
The third paragraph of this section is revised to read as follows:

“The roadway width shall be increased on curved portions of the Special Detour to account for the
off tracking characteristics of WB-62 vehicle in accordance with **the AASHTO publication A
Policy On Geometric Design of Highways and Streets (the Green Book), chapter 3 table
entitled Design Widths of Pavements for Turning Roadways.**”

SECTION 527 **ENERGY ABSORBING UNIT**

527.02 Materials This section is revised to read as follows.

527.02 Materials Work Zone Crash Cushions must comply with NCHRP Report 350. Work Zone Crash Cushions shall be selected from MaineDOT's Qualified Products List of Crash Cushions / Impact Attenuators, or an approved equal.

SECTION 534 **PRECAST STRUCTURAL CONCRETE**

534.14 Process Control Test Cylinders

Revise this subsection to read:

“534.14 Acceptance and Quality Control Testing of Concrete Refer to Section 712.061.”

SECTION 535

PRECAST, PRESTRESSED CONCRETE SUPERSTRUCTURE

Section 535.08 – Quality Assurance

Revise the second paragraph to read:

“The QAI will perform acceptance sampling and testing and will witness or review documentation, workmanship and testing to assure the Work is being performed in accordance with the Contract Documents.”

Section 535.15 - Process Control Test Cylinders

Revise the first paragraph to read:

“535.15 Acceptance and Quality Control Testing of Concrete Acceptance of structural precast/prestressed units, for each day's production, will be determined by the Department, based on compliance with this specification and satisfactory concrete testing results. At least once per week, the QAI will make 2 concrete cylinders (6 cylinders when the Contract includes permeability requirements) for use by the Department; cylinders shall be standard cured in accordance with AASHTO T23 (ASTM C31). The QAI will perform entrained air content and slump flow testing, determine water-cement ratio and determine temperature of the sampled concrete at the time of cylinder casting. All testing equipment required by the QAI to perform this testing shall be provided in accordance with Standard Specification Section 502.041, Testing Equipment. In addition, the Contractor shall provide a slump cone meeting the requirements of AASHTO T 119. Providing and maintaining testing and curing equipment shall be considered incidental to the work and no additional payment will be made.”

Insert the following as the second paragraph of Section 535.15:

“Quality Control concrete test cylinders shall be made for each day’s cast and each form bed used. Cylinders tested to determine strand release strength and design strength shall be field cured in accordance with AASHTO T23 (ASTM C31). 28 day cylinders shall be standard cured. Record unit identification, entrained air content, water-cement ratio, slump flow and temperature of the sampled concrete at the time of cylinder casting.”

SECTION 604 **MANHOLES, INLETS CATCH BASINS**

604.04 Adjusting Catch Basins and Manholes,

Add the following paragraph to the end of 604.04 b:

The Department will allow the use of metal ring inserts set into the manhole top frame or composite risers placed beneath the manhole frame to adjust manhole slope and grade for paving projects. The use of metal ring inserts shall be in accordance with 604.04 d. Ring Insert Requirements. The use of composite risers shall be in accordance with 604.04 e. Composite Riser Requirements.

Add the following paragraph after the first paragraph of 604.04 c:

The Department will allow the use of metal ring inserts set into the manhole top frame or composite risers placed beneath the manhole frame to adjust manhole slope and grade for paving projects. The use of metal ring inserts shall be in accordance with 604.04 d. Ring Insert Requirements. The use of composite risers shall be in accordance with 604.04 e. Composite Riser Requirements.

Add the following sections to 604.04:

d. Ring Insert Requirements Ring inserts to adjust manhole top frame slope and grade will be allowed in accordance with the following requirements:

1) Materials

- i. All ring inserts must be made of iron. *Multiple ring inserts will not be allowed.* The single ring insert may be any height up to a maximum of 2 inches tall.**
- ii. Ring inserts shall not be welded to the manhole frame to prevent brittle failure of the cast iron frame.**

- iii. Ring inserts shall be fastened to the manhole frame using liquid steel-filled epoxy such as Loctite Fixmaster Steel Liquid or equivalent. The epoxy shall be installed in accordance with the manufacturer's recommendations.

2) Where Ring Inserts May/May Not Be Used

- i. MaineDOT will allow the use of a single manhole ring insert to raise manholes on state and state-aid highways.
- ii. *Manhole ring inserts may not be used along state and state-aid highway sections where the speed limit is 40 miles per hour or more.* The standard brick and mortar or flat composite risers beneath the manhole frame must be used at these locations.

3) Construction Requirements For The Use of Iron Manhole Ring Inserts

- i. Wherever iron ring inserts are used to raise manhole top elevations, the rings shall be fastened to the existing manhole frame using liquid steel-filled epoxy. The liquid steel-filled epoxy shall be placed evenly around the entire manhole frame before placing the ring insert. *Unbonded ring inserts will not be allowed.* If the manufacturer's recommended construction practices result in loose or unacceptable manhole cover restraint, standard brick and mortar or flat composite risers beneath the manhole frame must be used at these locations.

e. Composite Riser Requirements Flat or beveled, doughnut-shaped, composite risers placed beneath the manhole frame to adjust slope and grade are allowed. The composite riser shall be fastened to both the top of the concrete cone and bottom of the manhole frame with the manufacturer's recommended epoxy. Composite risers may be used at all locations on state and state-aid highways under any legal speed limit without restriction.

SECTION 606
GUARDRAIL

606.09 Basis of Payment Amend the first sentence of the eighth paragraph of this subsection by removing the word "meter" and replace it with "linear foot".

SECTION 608
SIDEWALKS

608.021 Sidewalk Materials Revise this section by removing the second paragraph which begins with "Portland cement concrete shall..." in its entirety and replace with "**Portland cement concrete shall be Class A and meet the requirements of Section 502, Structural Concrete.**"

SECTION 609
CURB

609.03 Vertical Stone Curb, Terminal Section and Transition Sections and Portland Cement Concrete Curb, Terminal Sections and Transition Sections

Amend this section by adding the following paragraph to the end of it:

“The Contractor may elect to substitute concrete to backfill Stone Curbing or Stone Edging at their option. If the concrete backfill option is elected, the following is added to Standard Specification 609 – Curb”

609.02 Materials Amend this section by adding the following to it:

Portland cement and Portland Pozzolan Cement	701.01
Water	701.02
Fine Aggregate for Concrete	703.01
Coarse Aggregate for Concrete	703.02

The Contractor shall submit a concrete mix design for the Portland Cement Concrete to the Resident, with a minimum designed compressive strength of 4000 psi Class A concrete.

609.10 Basis of Payment Revise by changing the fifth paragraph which begins with “There will be no separate payment...” this section by removing the word “cement” and replacing it with “concrete fill, mortar”.

SECTION 619
MULCH

619.07 Basis of Payment Amend this section by adding the words “; **Bark Mulch and Erosion Control Mix will be paid for by the Cubic Yard;**” into the first sentence so that it reads:

“The accepted areas mulched will be paid for at the contract price per unit; **Bark Mulch and Erosion Control Mix will be paid for by the Cubic Yard;** which shall be full compensation for furnishing and spreading the hay or straw and mulch binder, cellulose fiber mulch, bark mulch or erosion control mix.

Revise the second sentence by removing “ **for pay item 619.1201**” So that it reads:

“When Mulch is measured in Bales, each bale will be paid for at 60% of the contract price per Unit”.

Revise this section by removing all pay items and replace them with the following:

619.12 Mulch	Unit
619.13 Bark Mulch	Cubic Yard
619.14 Erosion Control Mix	Cubic Yard

SECTION 621
LANDSCAPING

621.0002 Materials - General

In the list of items change “Organic Humus” to “**Humus**”.

621.0019 Plant Pits and Beds

c Class A Planting

In the third paragraph beginning with “ The plant pit...” change “½ inch” to “**1 inch**”

SECTION 626
**FOUNDATIONS, CONDUIT AND JUNCTION BOXES FOR HIGHWAY
SIGNING, LIGHTING AND SIGNALS**

626.02 General Amend the Material list by adding the following to the list:

Gravel Borrow	703.20
---------------	--------

Revise the Material List by removing:

Prewired Conduit	715.04
Metallic Junction and Fuse Box	715.05

626.021 Miscellaneous Material Amend this section by adding the following to the end of it:

“All concrete for concrete encasement of conduit shall be Fill Class concrete in accordance with the applicable requirements of Section 502 – Structural Concrete.”

Amend the third paragraph that begins with “If grouting is necessary...” by adding “**included on the Qualified Product List and**” after the word “material”.

626.03 General Amend this section by adding the following section to the end of it

“626.0301 Electrical Supply Lines and Service Connections The following requirements shall apply to Electric Supply Lines and Service Connections feeding traffic signalization equipment control boxes and lighting breaker boxes.

Whenever possible, the meter and breaker panel feeding traffic signal control boxes or lighting control boxes shall be constructed within 30 feet of the service drop pole.

All underground service connections that are constructed in trenches and carrying Secondary Utility Power to a MaineDOT meter and breaker panel, or, directly to MaineDOT traffic signalization control cabinets or lighting breaker boxes shall be in Rigid Metal Conduit or concrete encased PVC conduit.

Where trenchless technologies are employed to install the service connection conduit, Schedule 120 PVC conduit shall be used for the trenchless bore section of conduit. In addition, concrete encasement shall be used for any PVC conduit placed in trench sections and carrying Secondary Utility Power more than 10 feet before or after the limits of the trenchless bore conduit.

The construction practices described above shall be used for service connections up to a maximum of 600 feet. There may be rare exceptional cases where the service connection must exceed 600 feet. In these cases, the power companies may require primary power be run over 600 feet for the purpose of power consumption and dependable service. These cases will be evaluated on a case-by-case basis for alternate power feed methods and/or the need for steel or concrete encased conduit.”

626.031 Conduit Revise this section by removing the second paragraph which begins with “Trenches for conduits...” and replace it with the following:

“Trenches for conduits shall be excavated to a width that will permit proper installation of the conduit and to a minimum depth of 3 feet below finish grade as measured from the top of the conduit. If deeper depths are required, the conduit shall be installed at the depth shown on the plans or as directed. Conduit shall not interfere with poles, guardrail posts, sign foundations or other objects.”

Amend the third paragraph which begins with “All junction or pull boxes...” by adding “**concrete, in accordance with the applicable requirements of Section 502 – Structural Concrete,**” after Class LP.

Revise the fifth paragraph which begins with “After the trench has been...” by adding the following to the end of it:

“Where concrete encasement is required around the conduit, backfilling with approved material may begin adjacent to and above the encased conduit no sooner than 24 hours after concrete placement.”

Remove the following:

“All underground conduit shall be placed to at least the depth shown on the plans and shall not interfere with poles, guardrail posts, sign foundations or other objects.”

Revise the paragraph beginning with “All conduit ends shall...” by removing “Prewired Conduit shall be sealed during construction to prevent entry of moisture, dirt, or rocks.”

626.033 Polyvinylchloride Conduit Installation Amend the first paragraph of this section which begins with “Polyvinylchloride conduit and High Density...” by adding the following to the end of it:

“In addition, PVC conduit used for Electrical Supply Lines and Services constructed as underground service connections in trenches and carrying Secondary Utility Power to a MaineDOT meter and breaker panel, or, directly to MaineDOT traffic signalization control cabinets or lighting breaker boxes shall be concrete encased. When trenchless technologies are used to install PVC conduit, concrete encasement shall not be required.

Concrete encasement shall consist of a minimum of 4 inches of concrete above, below and on both sides of the conduit that shall have a minimum compressive strength of 3000 psi and a maximum aggregate size of 1-inch (Fill Class concrete). The concrete encasement may be backfilled no sooner than 24 hours after placement. “

“NON-METALLIC UNDER PAVEMENT CONDUIT INSTALLATION

Where noted on the drawings, non-metallic under pavement conduit of schedule 80 or greater rating shall be provided to facilitate conduit crossing of the existing highway and ramps without disruption to the existing highway and ramp pavement surface. The non-metallic under pavement conduit shall be hydraulically jacked or directional bored below the highway and ramp at a depth of not less than (36 inches). Under pavement conduit shall extend for a distance of (10 feet) beyond the highway or ramp edge at each side.”

Amend the sixth paragraph which begins with “Where PVC conduit runs are...” by changing “3 inch minimum bedding” to “**6 inch minimum bedding**”.

626.034 Concrete Foundations

Revise this section by removing the third paragraph which begins with “In the absence of Design Requirements...” in its entirety and replace with the following:

“In the absence of design requirements being provided on the plans, the Contractor shall prepare and submit the foundation design(s) to the Department for review. The Contractor may propose an alternate shallow spread footing or drilled shaft configuration/design than that set forth on the drawings. Design shall be in accordance with AASHTO LRFD Specifications for Structural Supports for Highway Sign, Luminaires and Traffic Signals, current edition; AASHTO LRFD Bridge Design Specifications, current edition; and FHWA-NHI-10-016 Drilled Shafts, Construction Procedures and Design Methods, current edition. Where conflicting requirements occur, the more stringent requirements shall govern. In addition to other design requirements, foundation design shall account for Torsion for which a minimum Factor of Safety equal to 1.2 shall be achieved. In evaluating axial capacity and torsional resistance in cohesionless soils, load transfer coefficient or side resistance coefficient (beta, β) will be used in accordance with Subsection 13.3.5.1 of FHWA-NHI-10-016, with beta determined in accordance with Equations 13-13 and 13-11 for silty sands to sandy silts (with varying amounts of gravel).

The design criteria for the resistance of drilled shaft and spread footing foundations against overturning, sliding and bearing capacity failure shall meet the requirements of Section 4 of AASHTO LRFD Bridge Design Specifications, current edition. The structural design of foundations shall meet the requirements of AASHTO LRFD Bridge Design Specifications, current edition. The Contractor shall submit to the Department for review, three (3) copies of detailed plans and calculations of the proposed design. Design shall be prepared and sealed by a Professional Engineer licensed in the State of Maine. Construction of foundation(s) shall not commence until the Department has reviewed the foundation design.”

On Page 6-85, add the following paragraph before the paragraph beginning with “Drilled shafts shall not be...”.

“ No foundation design will be required for 18- and 24-inch diameter foundations for structures less than 30-feet tall and with no projecting arms. A foundation design prepared by a Professional Engineer licensed in accordance with the laws of the State of Maine will be required for all other foundations Precast foundations will be permitted for 18 and 24-inch diameter foundations for structures less than 30-feet tall and with no projecting arms. Where precast foundations are permitted flowable concrete fill shall be used as backfill in the annular space, and placed from the bottom up. Construction of precast foundations shall conform to the Standard Details and all requirements of Section 712.061 except that the concrete shall have a minimum permeability of 17 kOhm-cm and the use of calcium nitrite will not be required. “

On Page 6-86, Revise the paragraph beginning with “Concrete for drilled shafts...” so that a portion of it reads as follows:

“The Contractor shall provide temporary dewatering of excavations for foundations such that concrete is placed in the dry. Concrete for drilled shafts shall be placed in accordance with Section 502.10 as temporary casing is withdrawn to prevent debris from contaminating the foundation and to ensure concrete is cast against the surrounding soil. Concrete for drilled shafts and spread footings shall be Class LP in accordance with Section 502 - Structural Concrete. Precast foundations will not be permitted except as specified above in this Section. Backfill for spread footing foundations shall be Gravel Borrow meeting the requirements of Section 703.20 - Gravel Borrow.....”

626.05 Basis of Payment Amend this section by removing the following paragraphs:
The one which starts with “Payment will be made for the total number of linear feet of prewired conduit...”

The one which starts with “Prewired conduit within the foundations...”

Amend this subsection by adding the following paragraph and Pay Items:

“Payment will be made for the total number of linear feet of under pavement conduit actually furnished, installed and accepted at the contract price per linear foot. This price shall include the cost of: furnishing and installing the conduit; excavating; furnishing special backfilling materials, pull wire, fittings, grounding and bonding; test cleaning interiors of conduits and all materials, labor, equipment and incidentals necessary to complete the work.”

Pay Item	PayUnit
626.221 Non-metallic Conduit, Concrete Encased	Linear Foot
626.251 Non-Metallic Under pavement Conduit (Schedule 80 or greater rating)	Linear Foot

Remove the following Pay Items:

626.23 Prewired Conduit Secondary Wiring	Linear Foot
626.24 Prewired Conduit Primary Wiring	Linear Foot

SECTION 627 **PAVEMENT MARKINGS**

Revise this section by removing it in its entirety and replacing with the following:

627.01 Description This work shall consist of furnishing and placing reflectorized pavement lines and markings, removing pavement lines and markings, and furnishing and applying reflectorized paint to curbing in reasonably close conformity with the plans and as designated.

627.02 Materials Materials shall conform to the requirements specified in the following Sections of Division 700 - Materials.

Pavement Marking Paint	708.03
Reflectorized Plastic Pavement Marking	712.05

Temporary Bi-directional Yellow Delineators shall be Temporary Object Markers (T.O.M.) as manufactured by the Davidson Plastic Company, 18726 East Valley Highway, Kent, WA 98031 or an approved equal.

627.04 General All pavement lines and markings shall be applied in accordance with the latest edition of Manual on Uniform Traffic Control Devices.

Longitudinal lines placed on tangent roadway segments shall be straight and true. Longitudinal lines placed on curves shall be continuous smoothly curved lines consistent with the roadway alignment. All pavement markings placed shall meet the tolerance limits shown on the plans.

Unless otherwise shown on the plans, non-interstate lines shall be 4 inches wide and broken lines shall consist of alternate 10 foot painted line segments and 30 foot gaps. On controlled access divided highways and on the interstate system lines shall be 6 inches wide and broken lines shall consist of alternate 15 foot painted line segments and 25 foot gaps. Width tolerance shall be +/- 1/4 inch.

Temporary pavement marking lines, defined in Special Provision Section 652, Maintenance of Traffic, Temporary Centerline, will be applied as many times as necessary to properly delineate traffic lanes for the safe passage of traffic. Bi-directional delineators may be used in place of temporary lines, except where specified otherwise in Special Provision 652 Maintenance of Traffic, Temporary Centerline. Delineators will be applied at 40 foot intervals.

In overnight lane closure areas that are not to be overlaid, temporary plastic lines or raised pavement markers shall be used through the length of the taper.

Newly painted lines, markings and curb shall be protected from traffic by the use of cones, stationary vehicles or other approved methods until the paint is dry.

627.05 Preparation of Surface Immediately before applying the pavement marking paint to the pavement or curb, the surface shall be dry and entirely free from dirt, grease, oil, or other foreign matter.

Surface preparation for application of plastic markings shall conform to the manufacturer's recommendations.

627.06 Application Prior to applying paint for final pavement lines, the Contractor shall perform a test for paint thickness by furnishing and placing a piece of smooth, clean metal with an area of at least 144 in² in the path of the striping truck. The striping truck shall be passed over the piece of metal, painting the surface as it passes, without applying beads. The result of this test will be used to determine the pressure setting and speed of the truck when applying paint to obtain the specified thickness. Additional paint thickness testing may be required on the final paint markings. The wet thickness of paint without beads on final pavement lines shall be a minimum of 16 mils.

On other final pavement markings and on curb, where the paint is applied by hand painting or spraying, application shall be in two uniform covering coats, each at least 10 mils thick. Before the second coat of paint has dried, the glass beads shall be applied by a pressure system that will force the glass beads onto the undried paint as uniformly as possible.

Glass beads shall be applied to the final and temporary pavement lines, marking and curb at a sufficient rate and in sufficient quantity to assure complete and uniform coverage of hand painted surfaces and achieve proper reflectivity.

Permanent and temporary white lines and markings shall have a minimum final reflectivity value of 250 millicandelas per square meter per lux (mcd/m²/lux) and permanent and temporary yellow lines and markings shall have a minimum final reflectivity value of 150 millicandelas per square meter per lux (mcd/m²/lux), as measured by the Department. Measurements taken to determine reflectivity shall be done within 4 weeks after final placement.

If the final reflectivity values are less than the described minimums, the Contractor shall repaint those areas not meeting required reflectivity at no cost to the Department. If the final reflectivity values are less than the described minimums after the second attempt, the Contractor will submit in writing a plan of action to meet the reflectivity minimums prior to continuing any work. Once the plan has been reviewed and approved by the Department, the Contractor shall re apply at no cost to the Department.

Temporary painted lines and markings shall be applied as specified for permanent painted lines, except that the thickness shall be a minimum of 16 mils.

Temporary pliant polymer marking material shall be used for temporary markings on the final pavement and on pavements not to be resurfaced when such pavement markings do not conform to the final pavement markings pattern.

The plastic final pavement lines and markings shall be applied in accordance with the manufacturer's recommendations by the inlay method of application.

627.07 Establishment Period Inlaid plastic pavement lines and marking material furnished and installed under this contract for final pavement markings shall still be subject to a six-month period of establishment.

The period of establishment shall commence as soon as the plastic pavement lines and markings are complete and in place and shall continue for six months. At the end of the establishment period, a minimum of 95% of the plastic pavement lines and markings shall still be in place to be acceptable.

If less than 95% of the plastic pavement lines and markings are in place after six months, the Contractor shall replace all unsatisfactory plastic pavement lines and markings on the project without additional payment. Plastic pavement lines and markings designated for replacement shall be installed according to these specifications, unless otherwise directed. Plastic pavement lines and markings replaced at the end of the six month establishment period will not be subject to a further establishment period.

627.08 Removing Lines and Markings When it is necessary to remove pavement lines and markings, it shall be done by high pressure water, grinding or other approved acceptable means. The method chosen must be capable of completely eradicating the existing line or marking without excessive damage to the pavement. Burning and the use of solvents to remove temporary markings from final pavement or from existing pavement not to be resurfaced will not be permitted.

627.09 Method of Measurement The quantity of pavement marking lines identified in the contract as a plan quantity pay item, the measurement of payment will be the number of feet shown in the Schedule of Items. This quantity will be considered final and no adjustments will be made except when changes resulting in increases or decreases are made by the Resident.

The accepted quantity of temporary or permanent pavement marking lines when identified in the contract as a linear foot item shall be measured and paid for at the contract unit price per linear foot for the total amount applied and accepted.

Double yellow centerline, broken or solid, will be considered one line for measurement purposes. The measurement of broken lines will include the gaps when painted and will not include the gaps when plastic. Double Yellow Centerline, broken or solid shall not be paid through intersections or side roads and will be paid for the actual length of painted line.

Broken white lines will include the gaps when painted and will not include the gaps when plastic inlaid pavement lines are applied. Yellow or white solid edge lines and will not be paid through intersections or side roads and will be measured by the actual length of painted line.

Temporary pavement marking lines shall not be paid through intersections or side roads and will be measured per linear foot of actual length of painted and accepted.

Reflectorized curb will be measured or computed by the square foot of curb surface actually painted and reflectorized.

The accepted quantity of removing existing pavement markings will be measured by the square foot.

Temporary Bi-directional Yellow Delineators will be measured by each unit, complete in place, maintained, and accepted.

627.10 Basis of Payment The accepted quantity of pavement marking lines identified in the contract as a plan quantity pay item will be paid for at the contract unit price for plan quantity. No adjustment will be made to the quantity for payment, except as described 627.09 Method of Measurement

The quantity of permanent or temporary pavement marking lines identified in the contract paid by the linear foot will be measured for payment as described under section 627.09 Method of Measurement.

All other permanent pavement markings will be paid for at the contract unit price per square foot in accordance with 627.09 Method of Measurement.

If allowed by Special Provision, the Contractor may utilize Temporary Bi-Directional Yellow and White (as required) Delineators. When utilized, payment will be made as temporary pavement marking lines, measured and paid at the contract unit price per linear foot. Such payment will include as many applications as required and removal.

Payment for final plastic pavement lines and markings will be made in two parts. The first payment of 75% will be made when plastic pavement lines and markings are placed. The payment of the remaining 25% will be made at the end of the establishment period for all plastic line and pavement markings accepted.

The accepted quantity of any pavement marking lines will be paid for at the contract unit price and will include as many applications as required and removal when required.

The accepted quantity of Temporary Bi-directional Yellow Delineators will be paid for at the contract unit price.

Payment will be made under:

<u>Pay Item</u>	<u>Pay Unit</u>
627.18 12 inch Solid White Pavement Marking Line	Linear Foot
627.711 White or Yellow Pavement Marking Line - Plan Quantity	Linear Foot
627.733 4" White or Yellow Painted Pavement Marking Line	Linear Foot
627.744 6" White or Yellow Painted Pavement Marking Line	Linear Foot
627.75 White or Yellow Pavement & Curb Marking	Square Foot
627.77 Removing Existing Pavement Marking	Square Foot
627.78 Temporary 4" Painted Pavement Marking Line, White or Yellow	Linear Foot
627.781 Temporary 6" Painted Pavement Marking Line, White or Yellow	Linear Foot
627.407 Reflectorized Plastic, White or Yellow Pavement Marking	Square Foot
627.4071 Reflectorized Plastic, White or Yellow Pavement Marking Line - Plan Quantity	Linear Foot
627.811 Temporary Bi-directional Yellow Delineators	Each

SECTION 639 **ENGINEERING FACILITIES**

Revise this section by removing this section in its entirety and replace with the following:

639.01 Description This work shall consist of providing, erecting, lighting, equipping and maintaining buildings to be solely used by the Resident and other assigned Department representatives as a field office. Upon completion of the work, the buildings and equipment shall remain the property of the Contractor.

639.02 Materials Materials for buildings shall be of good quality customarily used in standard frame house or office trailer construction.

639.03 General The building of the type called for shall be provided before the start of work, and shall remain until work is completed and accepted, unless earlier removal is authorized. The location shall be approved by the Resident and should be adjacent or virtually adjacent to the Project.

A fire extinguisher shall be provided in each building or office trailer for electrical and chemical fires and effective on all solvents used in the building.

Walls, roof, floor, windows, and doors shall be tightly constructed to the required area.

Furnishings shall be supplied as called for. Doors shall be equipped with locks and all keys shall be in the possession of the Resident. Windows shall be equipped with latches so they may be locked on the inside. Window screens and screen doors shall be supplied when necessary. Adequate desk and desk space shall be provided. If a portable table is supplied, it should be adjustable to accommodate the various heights of employees. A 5-way adjustable office chair shall be provided in the quantities listed.

639.04 Field Offices Field Offices are designated Type A, Type B, or Type C. Buildings, including trailers, may be provided if they substantially equal or exceed the following requirements. Air conditioning, appropriate to the building size, shall be provided in all field offices.

The walls, roof, and floor of the building shall be completely insulated with a minimum insulation value of R-15. Office trailers shall be either new or in very good used condition. The interior walls shall be covered with suitable wall paneling. The entire office trailer shall be for the exclusive use of the Resident. The office trailer shall be winterized and completely enclosed at the bottom, if the trailer will be used in cold weather.

Other types of buildings and facilities may be furnished of equal or better quality. A public work area will be provided in the field office that shall be designed and constructed so that individuals with disabilities can approach, enter, and exit this area.

At least one accessible route to the field office shall be provided from accessible parking. The accessible route shall comply with the Americans with Disabilities Act Accessibility Guidelines (ADAAG) and this specification.

The minimum clear width of an accessible route shall be 36 inches except at doors. The least possible slope shall be used for an accessible route. An accessible route with a running slope greater than 1:20 shall be considered a ramp. Maximum ramp slope is 1:12. The maximum rise for any run of a ramp shall be 30 inches and the minimum clear width shall be 36 inches. Nowhere shall the cross slope of an accessible route exceed 1:50. Changes in level up to ¼ inch may be vertical and without edge treatment. Changes in level between ¼ inch and ½ inch shall be beveled with a slope no greater than 1:2. Ramp floor surfaces shall be stable, firm, and slip-resistant.

Ground floor surfaces along accessible routes and in accessible rooms and spaces including floors, walks, ramps, stairs, and curb ramps, shall be stable, firm, and slip-resistant.

The main door to the public work area shall have a minimum clear opening of 32 inches with the door opened 90 degrees, measured between the face of door and the opposite stop. Minimum maneuvering clearances at doors shall be provided. The floor or ground area within the required clearances shall be level and clear.

The handle and other operating devices on accessible doors shall have a shape that is easy to grasp with one hand and does not require tight grasping. Lever-operated mechanisms push type mechanisms, and U-shaped handles are acceptable designs. Hardware required for accessible door passage shall be mounted no higher than 48 inches above finished floor. A minimum of 3 parking spaces will be supplied for Class B & C Field Offices and 6 for Class A. One wheelchair accessible parking space shall be located on the shortest accessible route of travel from adjacent parking to an accessible entrance.

Level landings shall be provided at bottom and top of each run. The landing shall be at least as wide as the ramp run leading to it with a minimum length of 60 inches.

If a ramp run has a rise greater than 6 inches or a horizontal projection greater than 72 inches, then it shall have handrails on both sides. Handrails shall have the following features:

- 1) Handrails shall be provided along both sides of ramp segments. The inside handrail on switchback ramps shall always be continuous.**
- 2) If handrails are not continuous, they shall extend at least 12 inches beyond the top and bottom of the ramp segment and shall be parallel with the floor or ground surface.**

- 3) The clear space between the handrail and the wall shall be 1½ inch.
- 4) Gripping surfaces shall be continuous.
- 5) Top of handrail gripping surfaces shall be mounted between 34 and 38 inches above ramp surfaces.
- 6) Ends of handrails shall be either rounded or returned smoothly to floor, wall, or post.
- 7) Handrails shall not rotate within their fittings.
- 8) The diameter or width of the gripping surfaces of a handrail shall be 1¼ to 1½ inch, or the shape shall provide an equivalent gripping surface.

Firm and sturdy steps shall also be provided with 7 inch maximum riser and 11 inch minimum depth, and at least one handrail extending from the top of the steps to a minimum 12 inches beyond the bottom of the steps.

The Contractor will make reasonable effort(s) to provide wheelchair accessible toilet facilities when "portable" facilities are provided.

The Contractor shall provide wheelchair accessible toilet facilities when flush type facilities, that is, those with running water, are provided; and the Contractor shall provide wheelchair accessible portable facilities, if used, when the contract duration exceeds two continuous construction seasons.

In addition to the facilities previously specified in this subsection, each field office shall meet the following minimum requirements:

<u>Description</u>	<u>Quantity</u>		
	<u>Type A</u>	<u>Type B</u>	<u>Type C</u>
Floor Area (Outside Dimension) - ft ²	312	220	125
Inside Wall Height – feet	7	7	7
Window Area - ft ²	55	35	35
Drafting Table Surface Area - ft ²	15	15	15
Drafting Stools - each	2	1	1
Office Desks - each	2	1	1
Ergonomic Swivel Chairs -ea (5-way adjustable)	3	2	2
Folding Chairs - each	3	2	2
Lighting Units - each	4	2	2
Electric Wall Outlets - each	6	4	3
Power Strip Surge Protectors - each	3	2	1
Wall Closets - each	1	1	1
Plan Rack for minimum of 6 sets of plans	1	1	0
Toilet Facility	1	1	1
Wastebaskets - each	2	2	1

All windows shall be provided with shades or blinds.

The toilet facility shall be for the exclusive use of State personnel. If requested, the Contractor will supply a lock to ensure exclusive use.

The Resident will have the option to reject any furniture or supplies provided to the field office based on general condition.

One hundred ten volt, 60 cycle, continuous electric service shall be supplied for lighting and 15 amp duplex wall outlets. Lighting shall consist of florescent light units with rapid start bulbs or LED shop style lights located over the work areas for a minimum of 50 foot candles overall. At least one external light source will be provided.

Drafting surfaces shall be 40 inches above the floor and have shelves beneath. Shelves for plans and rolls shall also be furnished overhead. Drafting stools shall be approximately 28 inches high.

Desks shall be single or double pedestal standard office type, and shall be in addition to “built-in” type desks in the office trailer.

Field offices shall be furnished with one four-drawer letter size metal filing cabinet.

Wall closets shall be 21 inches wide, 15 inches deep, and at least 4 feet high.

Each office shall be furnished with a broom, dustpan, sweeping compound, trash bags, and with cleaning material for cleaning glass. If the field office is carpeted, then a vacuum cleaner will be provided. The contractor will be responsible for disposing of trash from the field office.

The Contractor shall provide a fully functional wireless desktop copier/scanner/printer, capable of copying field books, for the Resident’s use during the project. All maintenance and supplies, except paper, shall be the responsibility of the Contractor.

The Contractor shall provide bottled water and a microwave for the duration of the project. All maintenance and supplies shall be the responsibility of the Contractor. Alternate source of water, such as a water cooler, may be provided as approved by resident.

The Contractor shall provide a 4 cubic-foot refrigerator in the field office for the duration of the project.

Each office shall be furnished with a 10-person general-purpose first aid kit. The first aid kit shall be periodically inspected and refilled as necessary.

639.08 Heat Heat appropriate to the building size shall be supplied by the Contractor to maintain an acceptable room temperature during occupancy.

639.091 Broadband Connection The contractor will supply one computer broadband connection, modem lease and router. The router shall have wireless access and be 802.11n or newer capable. The type of connection supplied will be contingent upon the availability of services (i.e. DSL or Cable Broadband). It shall be the contractor's option to provide dynamic or static IP addresses through the service. The selected service will have a minimum download connection of 5.0 Mbps and 1.0 Mbps upload. The contractor shall be responsible for the installation charges and all reinstallation charges following suspended periods. Monthly service and maintenance charges shall be billed by the Internet Service Provider (ISP) directly to the contractor.

639.10 Method of Measurement Field office will be measured by the unit or lump sum for each building provided, equipped and maintained satisfactorily.

639.11 Basis of Payment The accepted quantity of field office will be paid for at the contract unit price each or lump sum which payment shall be full compensation for furnishing until contract completion, erecting, equipping, maintaining, furnishing electricity, heating, installing and maintaining toilet facilities and if necessary removing the buildings or office trailers.

Payment for these items will be made in 3 parts; the first payment of ½ to be made after the Contractor has supplied the building or office trailer and it has been approved. The remaining payments shall be made at intervals as follows:

A second payment of ¼ shall be made when one-half of the anticipated work has been completed.

The final payment of the remaining ¼ shall be made upon completion of the work.

Payment will be made under:

	<u>Pay Item</u>	<u>Pay Unit</u>
639.18	Field Office, Type A	Each
639.19	Field Office, Type B	Each
639.20	Field Office, Type C	Each

SECTION 652 **MAINTENANCE OF TRAFFIC**

652.2.4 Other Devices Revise this Section by removing the following paragraph:
“ STOP/SLOW paddles shall be the primary and preferred hand held signaling device. Flags shall be limited to Emergencies. The paddle shall have an octagonal shape and be at least 18 inches wide with letters at least 6 inches high and should be fabricated from semi-rigid material”

And replace with these two paragraphs

“Flaggers shall use a STOP / SLOW hand held paddle as the primary and preferred hand signaling device. Use of flags shall be limited to emergency situations.

STOP / SLOW paddles shall have high intensity prismatic retro reflective sheeting Type XI, have an octagonal shape on a rigid handle and shall be at least 18 inches wide with letters at least 6 inches high and shall be constructed from light semi-rigid material. The STOP (R1-1) face shall have white letters and a white border on a red background. The SLOW (W20-8) face shall have black letters and a black border on an orange background. Paddles in existing stock meeting the current specification (Type VII, Type VIII, or Type IX) may be utilized until the end of the service life or until 12/31/18. All new paddles must meet the Type XI requirements.”

652.3.3 Submittal of Traffic Control Plan On page 6-148, note f, in the last sentence revise the “105.2.2” to “105.2.3” so that the last sentence reads, **“For a related provision, see Section 105.2.3 – Project Specific Emergency Planning.”**

652.3.4 General Revise the eighth paragraph by removing “Earth Berm” and replace it with **“Concrete Barrier”**.

Amend this section by adding the following paragraph before the paragraph beginning with “Special Detours and temporary structures...”:

“A temporary ramp shall be constructed with HMA at the ends of the roadway section paved or milled each day. The use of millings or RAP will not be allowed, but cold patch may be temporarily utilized until HMA plants are open for the season. The maximum ramp change in elevation shall not exceed 4” vertical. For Interstate Highways or roadways with speed limits equaling or exceeding 50 mph; temporary ramps shall be constructed at a length of eight feet per inch of transition depth. For roadways with speed limits less than 50 mph and greater than 25 mph, temporary ramps shall be constructed at a length of four feet per inch of transition depth. For roadways with speed limits 25 mph or less, temporary ramps shall be constructed at a length of two feet per inch of transition depth. Materials, placement, maintenance, and removal shall be incidental to contract items.”

652.4 Flaggers Revise this section by removing the first paragraph, and replace it with the following”

“The Contractor shall furnish flaggers as required by the TCP or as otherwise specified by the Resident. All flaggers must have successfully completed a flagger test approved by the Department and administered by a Department-approved Flagger-Certifier. All flaggers must carry an official certification card with them at all times while flagging.

For daytime conditions, flaggers shall wear a top (vest, shirt or jacket) that is orange, yellow, yellow-green, or fluorescent versions of these colors meeting ANSI 107-2004, Class 2 or Class 3, along with a hardhat with 360 ° retro-reflectivity.

For nighttime conditions, flaggers shall wear all Class 3 apparel, meeting ANSI 107-2004, including a Class 3 top (vest, shirt or jacket) and a Class E bottom (pants or coveralls), shall be worn along with a hardhat with 360 ° retro-reflectivity and shall be visible at a minimum distance of 1000 ft. Flagger stations must be illuminated in nighttime conditions to assure visibility and will be specifically addressed in detail in the Contractor’s TCP”.

652.41 TRAFFIC OFFICERS

Revise this subsection so that the subsection number and title is

“652.4.1 TRAFFIC OFFICERS ”

SECTION 656

TEMPORARY SOIL EROSION AND WATER POLLUTION CONTROL

656.5.2 If No Pay Item Add the following to the end of the first paragraph:

“Failure by the Contractor to follow Standard Specification or Special Provision - Section 656 will result in a violation letter and a reduction in payment as shown in the schedule list in 656.5.1. The Department’s Resident or any other representative of The Department reserves the right to suspend the work at any time and request a meeting to discuss violations and remedies. The Department shall not be held responsible for any delay in the work due to any suspension under this item.”

SECTION 660

ON-THE-JOB TRAINING

660.06 Method of Measurement

Remove the first sentence in its entirety and replace with **“ The OJT item will be measured by the number of OJT hours by a trainee who has successfully completed an approved training program.”**

660.07 Basis of payment to the Contractor

Remove the last word in the first sentence so that the first sentence reads **“ The OJT shall be paid for once successfully completed at the contract unit price per hour.”**

Payment will be made under

Change the Pay Item from **“660.22”** to **“660.21”** and change the Pay Unit from **“Each”** to **“Hour”**.

SECTION 672

PRECAST CONCRETE BLOCK GRAVITY WALL

672.035 Backfill Material– Revise this section by adding the following after the second paragraph: **Backfill materials shall meet the criteria in the following table.**

<u>Base Polymer</u>	<u>Property</u>	<u>Criteria</u>	<u>Test Method</u>
Polyester (PET)	pH	3 < pH < 9	AASHTO T-289
Polyolefin (PP & HDPE)	pH	pH > 3	AASHTO T-289

672.04 Design Requirements – Revise this section by replacing items 2 and 3 in the second paragraph with the following:

2. FHWA-NHI-10-024 and FHWA-NHI-10-025, Design and Construction of Mechanically Stabilized Earth Walls and Reinforced Soil Slopes, Volumes I and II, current edition.
3. FHWA-NHI-09-087 Corrosion/Degradation of Soil Reinforcements for Mechanically Stabilized Earth Walls and Reinforced Soil Slopes, current edition.

SECTION 673 **WETCAST SMALL LANDSCAPE BLOCK WALL**

673.035 Backfill Material – Revise this section by adding the following after the second paragraph:

Backfill materials shall meet the criteria in the following table.

<u>Base Polymer</u>	<u>Property</u>	<u>Criteria</u>	<u>Test Method</u>
Polyester (PET)	pH	3 < pH < 9	AASHTO T-289
Polyolefin (PP & HDPE)	pH	pH > 3	AASHTO T-289

673.04 Design Requirements – Revise this section by replacing items 2 and 3 in the second paragraph with the following:

2. FHWA-NHI-10-024 and FHWA-NHI-10-025, Design and Construction of Mechanically Stabilized Earth Walls and Reinforced Soil Slopes, Volumes I and II, current edition.
3. FHWA-NHI-09-087 Corrosion/Degradation of Soil Reinforcements for Mechanically Stabilized Earth Walls and Reinforced Soil Slopes, current edition

SECTION 674

PREFABRICATED CONCRETE MODULAR GRAVITY WALL

674.02 Materials

Amend this section by adding the following after “Concrete Units:” and before the paragraph beginning with “Tolerances”.

Concrete shall be Class P. The concrete shall contain a minimum of 5.5 gallons per cubic yard of calcium nitrite solution.

The minimum permeability of the concrete as indicated by Surface Resistivity shall be 17 KOhm-cm.

Defects Defects which may cause rejection of precast units include, but are not limited to, the following:

Any discontinuity (crack, rock pocket, etc.) of the concrete which could allow moisture to reach the reinforcing steel.

Rock pockets or honeycomb over 6 square inches in area or over 1 inch deep.

Edge or corner breakage exceeding 12 inches in length or 1 inch in depth.

Any other defect that clearly and substantially impacts the quality, durability, or maintainability of the structure, as determined by the Fabrication Engineer.

Repair honeycombing, ragged or irregular edges and other non-structural or cosmetic defects using a patching material from the MaineDOT Qualified Products List (QPL). The repair, including preparation of the repair area, mixing and application and curing of the patching material, shall be in accordance with the manufacturer's product data sheet. Corners that are not exposed in the final product may be ground smooth with no further repair necessary if the depth of the defect does not exceed 1/2 inch. Remove form ties and other hardware to a depth of not less than 1 inch from the face of the concrete and patch the holes using a patching material from the MaineDOT QPL.

Repair structural defects only with the approval of the Fabrication Engineer. Submit a nonconformance report (NCR) to the Fabrication Engineer with a proposed repair procedure. Do not perform structural repairs without an NCR that has been reviewed by the Fabrication Engineer. Structural defects include, but are not be limited to, exposed reinforcing steel or strand, cracks in bearing areas, through cracks and cracks 0.013 inch in width that extend more than 12 inches in length in any direction. Give the QAI adequate notice prior to beginning any structural repairs.

SECTION 677

MECHANICALLY STABILIZED EARTH RETAINING WALL

677.03 Design Requirements – Revise this section by replacing items 6, 7 and 8 in the second paragraph with the following:

- 6. FHWA-NHI-10-024, Design and Construction of Mechanically Stabilized Earth Walls and Reinforced Soil Slopes, Volumes I, current edition.**
- 7. FHWA-NHI-10-025, Design and Construction of Mechanically Stabilized Earth Walls and Reinforced Soil Slopes, Volumes II, current edition.**
- 8. FHWA-NHI-09-087 Corrosion/Degradation of Soil Reinforcements for Mechanically Stabilized Earth Walls and Reinforced Soil Slopes, current edition**

On page 6 - 203 change “636.041” to “677.041”

Amend 677.042 Precast Panel Tolerances and Surface Finish by the addition of the following:

Defects Defects which may cause rejection of precast units include, but are not limited to, the following:

Any discontinuity (crack, rock pocket, etc.) of the concrete which could allow moisture to reach the reinforcing steel.

Rock pockets or honeycomb over 6 square inches in area or over 1 inch deep.

Edge or corner breakage exceeding 12 inches in length or 1 inch in depth.

Any other defect that clearly and substantially impacts the quality, durability, or maintainability of the structure, as determined by the Fabrication Engineer.

Repair honeycombing, ragged or irregular edges and other non-structural or cosmetic defects using a patching material from the MaineDOT Qualified Products List (QPL). The repair, including preparation of the repair area, mixing and application and curing of the patching material, shall be in accordance with the manufacturer's product data sheet. Corners that are not exposed in the final product may be ground smooth with no further repair necessary if the depth of the defect does not exceed 1/2 inch. Remove form ties and other hardware to a depth of not less than 1 inch from the face of the concrete and patch the holes using a patching material from the MaineDOT QPL.

Repair structural defects only with the approval of the Fabrication Engineer. Submit a nonconformance report (NCR) to the Fabrication Engineer with a proposed repair procedure. Do not perform structural repairs without an NCR that has been reviewed by the Fabrication Engineer. Structural defects include, but are not be limited to, exposed reinforcing steel or strand, cracks in bearing areas, through cracks and cracks 0.013 inch in width that extend more than 12 inches in length in any direction. Give the QAI adequate notice prior to beginning any structural repairs.

SECTION 702
BITUMINOUS MATERIAL

702.01 Asphalt Cement - Remove this section in its entirety and replace with the following:

Performance-Graded Asphalt Binder (PGAB) that has not been modified with polymer shall conform to the requirements of AASHTO M 320. Polymer modified binder shall meet the requirements of AASHTO M 332 (including Appendix X1), except that the percent difference in nonrecoverable creep compliance, J_{nr}diff, shall not be enforced. Performance-Graded Asphalt Binder shall not contain re-refined engine oil bottoms (REOB).

The Contractor shall arrange for the Supplier to furnish the following items to the Department's Asphalt Pavement Engineer:

a. A Quality Control Plan that conforms to the requirements of AASHTO R 26 "Certifying Suppliers of Performance-Graded Asphalt Binders" and

b. A CERTIFICATE OF ANALYSIS for all asphalt materials furnished for use on the project. The Certificate shall include the actual test results of the material in storage from which the shipments are being made. Certificates shall be supplied for each lot, batch, or blend of each type and grade of material. A new certificate shall be issued at least every 30 days or upon receiving or manufacture of a new material. The original of each Certificate of Analysis shall be mailed to the Departments Asphalt Pavement Engineer.

The Contractor shall give the supplier sufficient notice of orders to permit testing and certification. Material not certified will not be accepted for use.

Deliveries of asphalt materials shall be accompanied by a Bill of Lading containing the information required under Section 108.1.3 f. The Bill of Lading shall include the applicable certificate number and shall include a printed or stamped statement such as the following: "THIS IS TO CERTIFY THAT THE ASPHALT MATERIAL REPRESENTED BY THIS LOADING INVOICE CONFORMS TO THE SPECIFICATIONS OF THE PURCHASER FOR THE MATERIAL TYPE AND GRADE STATED THEREON."

In the event an intermediate hauler of the asphalt material is involved, a copy of their own delivery slip shall be furnished, as well as a copy of the supplier's loading invoice. The hauler's delivery slip and the supplier's loading invoice shall be cross-referenced by use of their respective serial numbers.

All non-bituminous components added to the binder prior to the sampling point for binder certification shall be included on the asphalt binder Certificate of Analysis identifying their presence. All non-bituminous components added after the certification sampling point and prior to transport shall be included on the Bill of Lading. All non-bituminous components added to the binder at the HMA plant shall be identified on the mix plant documentation and accompanied by test results and certification showing the effect of the additives introduced, if any.

702.04 Emulsified Asphalt

Revise this Section by removing the first paragraph in its entirety and replace with the following:

Emulsified Asphalt shall conform to the requirements of AASHTO M 140. Cationic emulsified asphalt shall conform to the requirements of AASHTO M 208. Anionic emulsified asphalt Grade RS-1h shall conform to the requirements in the following table:

Type	Rapid-Setting	
Grade	RS-1h	
Tests on Emulsions	min	max
Viscosity, Saybolt Furol at 25°C SFS	20	100
Storage Stability test, 24-h, % ^A	-	1.0
Demulsibility, 35 ml, 0.02 N CaCl ₂ , %	60	-
Sieve Test, % ^A	-	0.10
Residue by distillation, %	55	-
Tests on Residue from Distillation Test	min	max
Penetration, 25°C 100g, 5 s	40	90
Ductility, 25°C 5 cm/min, cm	40	-
Solubility in trichloroethylene or n-propyl bromide, %	97.5	-

^A This requirement is waived if successful application of material has been achieved in the field.

SECTION 703
AGGREGATES

703.01 Fine Aggregate for Concrete Replace the second paragraph with the following:

“All fine aggregate shall be free from injurious amounts of organic impurities. Should the fine aggregate, when subjected to the colorimetric test for organic impurities, AASHTO T 21, produce a color darker than organic plate number 3, the fine aggregate shall be rejected.”

703.0201 Alkali Silica Reactive Aggregates. Remove this section in its entirety and replace with the following:

All coarse and fine aggregates proposed for use in concrete shall be tested for Alkali Silica Reactivity (ASR) potential under AASHTO T 303 (ASTM C 1260), Accelerated Detection of Potentially Deleterious Expansion of Mortar Bars Due to Alkali-Silica Reaction, prior to being accepted for use. Acceptance will be based on testing performed by an accredited independent lab submitted to the Department. Aggregate submittals will be required on a 5-year cycle, unless the source or character of the aggregate in question has changed within 5 years from the last test date.

As per AASHTO T 303 (ASTM C 1260): Use of a particular coarse or fine aggregate will be allowed with no restrictions when the mortar bars made with this aggregate expand less than or equal to 0.10 percent at 30 days from casting. Use of a particular coarse or fine aggregate will be classified as potentially reactive when the mortar bars made with this aggregate expand greater than 0.10 percent at 30 days from casting. Use of this aggregate will only be allowed with the use of cement-pozzolan blends and/or chemical admixtures that result in mortar bar expansion of less than 0.10 percent at 30 days from casting as tested under ASTM C 1567.

Acceptable pozzolans and chemical admixtures that may be used when an aggregate is classified as potentially reactive include, but are not limited to the following:

Class F Coal Fly Ash meeting the requirements of AASHTO M 295.

Ground Granulated Blast Furnace Slag (Grade 100 or 120) meeting the requirements of AASHTO M 302.

Densified Silica Fume meeting the requirements of AASHTO M 307.

Lithium based admixtures

Metakaolin

Pozzolans or chemical admixtures required to offset the effects of potentially reactive aggregates will be incorporated into the concrete at no additional cost to the Department.

703.06 Aggregate for Base and Subbase - Remove the first two paragraphs in their entirety and replace with these:

“The following shall apply to Sections (a.) and (c.) below. The material shall have a Micro-Deval value of 25.0 or less as determined by AASHTO T 327. If the Micro-Deval value exceeds 25.0, the Washington State Degradation DOT Test Method T113, Method of Test for Determination of Degradation Value (January 2009 version) shall be performed, except that the test shall be performed on the portion of the sample that passes the ½ in sieve and is retained on the No. 10 sieve. If the material has a Washington Degradation value of less than 15, the material shall be rejected.

The material used in Section (b.) below shall have a Micro-Deval value of 25.0 or less as determined by AASHTO T 327. If the Micro-Deval value exceeds 25.0 the material may be used if it does not exceed 25 percent loss on AASHTO T 96, Resistance to Degradation of Small-Size Coarse Aggregate by Abrasion and Impact in the Los Angeles Machine. “

703.081 RAP for Asphalt Pavement

Remove this section in its entirety and replace with the following:

703.081 RAP for Asphalt Pavement Recycled Asphalt Pavement (RAP) may be introduced into hot-mix asphalt pavement at percentages approved by the Department according to the MaineDOT Policies and Procedures for HMA Sampling and Testing.

If approved by the Department, the Contractor shall provide documentation stating the source, test results for average residual asphalt content, and stockpile gradations showing RAP materials have been sized to meet the maximum aggregate size requirements of each mix designation. The Department will obtain samples for verification and approval prior to its use.

The maximum allowable percent of RAP shall be determined by the asphalt content, the percent passing the 0.075 mm sieve, the ratio between the percent passing the 0.075 mm sieve and the asphalt content, and Coarse Micro-Deval loss values as tested by the Department. The maximum percentage of RAP allowable shall be the lowest percentage as determined according to Table 4 below:

Table 4: Maximum Percent RAP According to Test Results

Classification	Maximum RAP Percentage Allowed	Asphalt content standard deviation	Percent passing 0.075 mm sieve standard deviation	Percent passing 0.075 mm sieve / asphalt content ratio	Residual aggregate M-D loss value
Class III	10%	≤ 1.0	N/A	≤ 4.0	≤ 18
Class II	20%	≤ 0.5	≤ 1.0	≤ 2.8	
Class I	30%	≤ 0.3	≤ 0.5	≤ 1.8	

The Department will monitor RAP asphalt content and gradation during production by testing samples from the stockpile at approximately 15,000 T intervals (in terms of mix production). The allowable variance limits (from the numerical average values used for mix designs) for this testing are determined based upon the maximum allowable RAP percentage, and are shown below in Table 5.

Table 5: RAP Verification Limits

Classification	Asphalt content (compared to aim)	Percent passing 0.075 mm sieve (compared to aim)
Class III	± 1.5	± 2.0
Class II	± 1.0	± 1.5
Class I	± 0.5	± 0.7

For specification purposes, RAP will be categorized as follows:

Class III – A maximum of 10.0 percent of Class III RAP may be used in any base, intermediate base, surface, or shim mixture. A maximum of 20.0 percent of Class III RAP may be used in hand-placed mixes for item 403.209.

Class II – A maximum of 20.0 percent Class II RAP in any base, binder, surface, or shim course.

Class I – A maximum of 20.0 percent Class I RAP may be used in any base, intermediate base, surface, or shim mixture without requiring a change to the specified asphalt binder. A maximum of 30.0 percent Class I RAP may be used in in any base or intermediate base mixture provided that a PG 58-28 asphalt binder is used. A maximum of 30.0 percent Class I RAP may be used in any surface or shim mixture provided that PG 58-34 or 52-34 asphalt binder is used. Mixtures exceeding 20.0 percent Class I RAP must be evaluated and approved by the Department.

The Contractor may use up to two different RAP sources in any one mix design. The total RAP percentage of the mix shall not exceed the maximum allowed for the highest classification RAP source used (i.e. if a Class I & Class III used, total RAP must not exceed 30.0%). The blended RAP material must meet all the requirements of the classification for which the RAP is entered (i.e. 10% Class III with 20% Class I, blend must meet Class I criteria). The Department may take belt cuts of the blended RAP to verify the material meets these requirements. If the Contractor elects to use more than one RAP source in a design, the Contractor shall provide an acceptable point of sampling blended RAP material from the feed belt.

In the event that RAP source or properties change, the Contractor shall notify the Department of the change and submit new documentation stating the new source or properties a minimum of 72 hours prior to the change to allow for obtaining new samples and approval.

703.19 Granular Borrow

Remove the gradation requirements table, and replace with the following:

Sieve Designation	Percentage by Weight Passing Square Mesh Sieves	
	Material for Underwater Backfill	Material for Embankment Construction
6 inch	100	
No. 40	0-70	0-70
No. 200	0-7.0	0-20.0

703.33 Stone Ballast - In the third paragraph, remove the words “less than” before 2.60 and add the words “or greater” after 2.60.

SECTION 708 **PAINTS AND PRESERVATIVES**

708.05 Timber Preservative Revise this section by removing it in its entirety and replacing with:
“Timber preservatives shall conform to the requirements of AASHTO M 133 and AWPA Standard U1. All preservatives shall meet the requirements of the US EPA regulations under the Federal Insecticide, Fungicide and Rodenticide Act.”

SECTION 709 **REINFORCING STEEL AND WELDED STEEL WIRE FABRIC**

709.01 Reinforcing Steel Revise this section by removing the sentence starting with “The chemical composition...” in the third paragraph and replace it with the following:
“The chemical composition shall conform to one of the types listed in Table 2 of ASTM A955 or UNS S32304 Duplex.”

SECTION 710 **FENCE AND GUARDRAIL**

710.07 Guardrail Posts Amend subsection ‘a’ by removing the words “white oak”, “cedar”, “tamarack”, “maple”, “beech”, “birch” and “red oak” from the first sentence. Also in the first sentence, place an “or” between “pine” and “eastern hemlock”. In the second sentence remove the words “well seasoned”. Remove the sentence beginning with “Wood posts and offset brackets...” and replace it with: **“Wood posts and offset brackets shall be preservative treated in accordance with the requirements of AASHTO M 133 and AWPA U1, UC4A Commodity Specification A: Sawn Products.”**

SECTION 712 **MISCELLANEOUS HIGHWAY MATERIAL**

712.061- Structural Precast Concrete Units

Under the heading, Quality Control and Quality Assurance, revise the fourth paragraph to read:

“Acceptance is the prerogative of the Department. The Department will conduct Quality Assurance (QA) in accordance with Standard Specification Subsection 106.5. Testing deemed necessary by the Department that is in addition to the minimum testing requirements will be scheduled to minimize interference with the production schedule. The QAI will perform acceptance sampling and testing and will witness or review documentation, workmanship and testing to assure the Work is being performed in accordance with the Contract Documents.”

Under the heading, Concrete Testing, revise the first paragraph to read as the following two paragraphs:

“Concrete Testing Acceptance of structural precast units, for each day’s production, will be determined by the Department, based on compliance with this specification and satisfactory concrete testing results.

At least once per week, the QAI will make 2 concrete cylinders (6 cylinders when the Contract includes permeability requirements) for use by the Department; cylinders shall be standard cured in accordance with AASHTO T23 (ASTM C31). The QAI will perform entrained air content and slump flow testing, determine water-cement ratio and determine temperature of the sampled concrete at the time of cylinder casting. All testing equipment required by the QAI to perform this testing shall be in accordance with Standard Specification Section 502.041, Testing Equipment. In addition, the Contractor shall provide a slump cone meeting the requirements of AASHTO T 119. Providing and maintaining testing and curing equipment shall be considered incidental to the work and no additional payment will be made.

Quality Control test cylinders shall be made and tested in accordance with the following standards:

AASHTO T 22 (ASTM C39) Test Method for Compressive Strength of Cylindrical Concrete Specimens

AASHTO T23 (ASTM C31) Practice for Making and Curing Concrete Test Specimens in Field

**AASHTO T141 (ASTM C172) Practice for Sampling Freshly Mixed Concrete
AASHTO T152 (ASTM C231) Test Method for Air Content of Freshly Mixed Concrete by the Pressure Method**

AASHTO T196 (ASTM C173) Standard Test Method for Air Content of Freshly Mixed Concrete by the Volumetric Method

ASTM C1064 Test Method for Temperature of Freshly mixed Portland Cement Concrete

ASTM C1611 Standard Test Method for Slump Flow of Self-Consolidating Concrete”

Under the heading, Concrete Testing, delete the paragraph that begins:

“At least once per week, the Contractor shall make 2 concrete cylinders.....for use by the Department.....”

SECTION 713 **STRUCTURAL STEEL AND RELATED MATERIAL**

Section 713.01- Structural Steel Revise this Section by removing the sentence:

“ Impact test sampling and testing procedures shall be in accordance with AASHTO T.”

And replace it with: **“Impact test sampling and testing procedures shall be in accordance with AASHTO T 243 M/T 243 and AASHTO T 244.”**

SECTION 717 ROADSIDE IMPROVEMENT MATERIAL

717.02 Agricultural Ground Limestone

In the table after the third paragraph which starts with “Liquid lime...” change the Specification for Nitrogen (N) from “15.5 percent of which 1% is from ammoniac nitrogen and 14.5 /5 is from Nitrate Nitrogen” to read “**15.5 % of which 1% is from Ammoniacal Nitrogen and 14.5 % is from Nitrate Nitrogen**”

717.061 Erosion Control Blankets Revise this section by removing it in its entirety and replacing it with the following:

“717.061 Erosion Control Blankets Shall consist of a machine produced rolled blanket of biodegradable fibers, evenly distributed over the entire area of blanket, of a consistent thickness, sewn into a biodegradable mesh on the top and bottom surface using a cotton blend thread. The blanket shall remain in place when subject to shear stress of 1.55 lb/ft². The blanket shall remain intact until grass is established. The blanket shall be a product currently listed on the department’s Qualified Products List (QPL) of Erosion Control Products. See Section 618.10 - Seeding, Maintenance and Acceptance.”

SECTION 720 STRUCTURAL SUPPORTS FOR HIGHWAY SIGNS, LUMINAIRES AND TRAFFIC SIGNALS

720.10 Wood Utility Pole Amend the first sentence in this section by adding “, **Red Pine**” after “Douglas Fir”.

Replace the paragraph beginning with “Wood Utility poles...” with:

“Wood Utility poles shall be pressure treated, after fabrication in accordance with AASHTO Specifications M 133 and AWPA U1, UC4B, Commodity Specification D: Poles.”

720.12 Wood Sign Posts Remove the first sentence and replace with “**Wood sign posts shall be rectangular, straight and sound timber, cut from live growing native spruce, red pine, hemlock or cedar trees, free from loose knots or other structurally weakening defects of importance, such as shake or holes or heart rot.**”

Remove the paragraph beginning with “When pressure treated sign posts are called for on the plans ...” with “**When pressure treated sign posts are called for on the plans, the wood shall be Yellow Pine, Number 2 or better, or the species listed above. The pressure treated wood shall meet AASHTO M 133 and AWPA Standard U1, UC4A, Commodity Specification A: Sawn Products.**”



Appendix B: Self-Verification Notification Form
(for all tidal and non-tidal projects in Maine subject to Corps jurisdiction)

**US Army Corps
of Engineers** ®
New England District

At least two weeks before work commences, complete **all** fields (write "none" if applicable) below or use the fillable form at www.nae.usace.army.mil/missions/regulatory.aspx. Send this form, a location map, any project plans, and an Official Species List (See GC 8) to the address noted below; fax to (207) 623-8206; or email to jay.l.clement@usace.army.mil. The two-week lead time is not required for emergency situations (see page 4 for definition). Please call (207) 623-8367 with questions.

Maine Project Office
U.S. Army Corps of Engineers
New England District
675 Western Avenue #3
Manchester, Maine 04351

State Permit Number: MaineDEP Exempt per 480-Q #17
Date of State Permit: _____
State Project Manager: _____

Permittee: Maine Department of Transportation (Applicant: Colin Greenan, ENV Team Leader)
Address, City, State & Zip: 16 State House Station Augusta, Maine 04333-0016
Phone(s) and Email: (207) 590-4632 colin.m.greenan@maine.gov

Contractor: To be determined; project will be advertised to a contractor.
Address, City, State & Zip: _____
Phone(s) and Email: _____

Consultant/Engineer/Designer: MaineDOT
Address, City, State & Zip: _____
Phone(s) and Email: _____

Wetland/Vernal Pool Consultant: MaineDOT
Address, City, State & Zip: _____
Phone(s) and Email: _____

Project Location/Description: Augusta, I-95 Ramp F (Exit 109, bridge over mainline)
Address, City, State & Zip: Exit 109 on I-95, Augusta, Maine (location map attached)
Latitude/Longitude Coordinates: Lat: 44.312990°N Long: -69.809085°W Tax Map/Lot: _____
Waterway Name: Freshwater wetlands only, no instream work

Work Description: Flatten the inslope of the eastbound side of ramp in order to remove a section of guardrail to improve site distance.
The removal of the guardrail will enable drivers on the eastbound ramp to better see northbound off ramp vehicles prior to the merge point.

Provide any prior Corps permit numbers: n/a
Proposed Work Dates: Start: 5/20/2018 Finish: 9/1/2018

Area of wetland impact: 3,200s.f. perm. 4,000s.f. temp. SF (leave blank if work involves structures & no fill in Navigable Waters)
Area of waterway impact: none SF (leave blank if work involves structures & no fill in Navigable Waters)
Area of compensatory mitigation provided: none SF

Work will be done under the following Appendix A categories (circle all that apply):

- I. Inland Waters and wetlands: 1 2 3 4 5 6 7 8 9 10 11 12 13 14 15 16 17 18 19 20 21 22 **23** 24
II. Navigable Waters: 1 2 3 4 5 6 7 8 9 10 11 12 13 14 15 16 17 18 19 20 21 22 23 24

Your name/signature below, as permittee, indicates that you accept and agree to comply with the terms, eligibility criteria, and general conditions of Category 1 of the Maine General Permit.

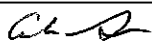
Permittee Printed Name: Colin Greenan for MaineDOT
Permittee Signature:  Date: 5/3/18

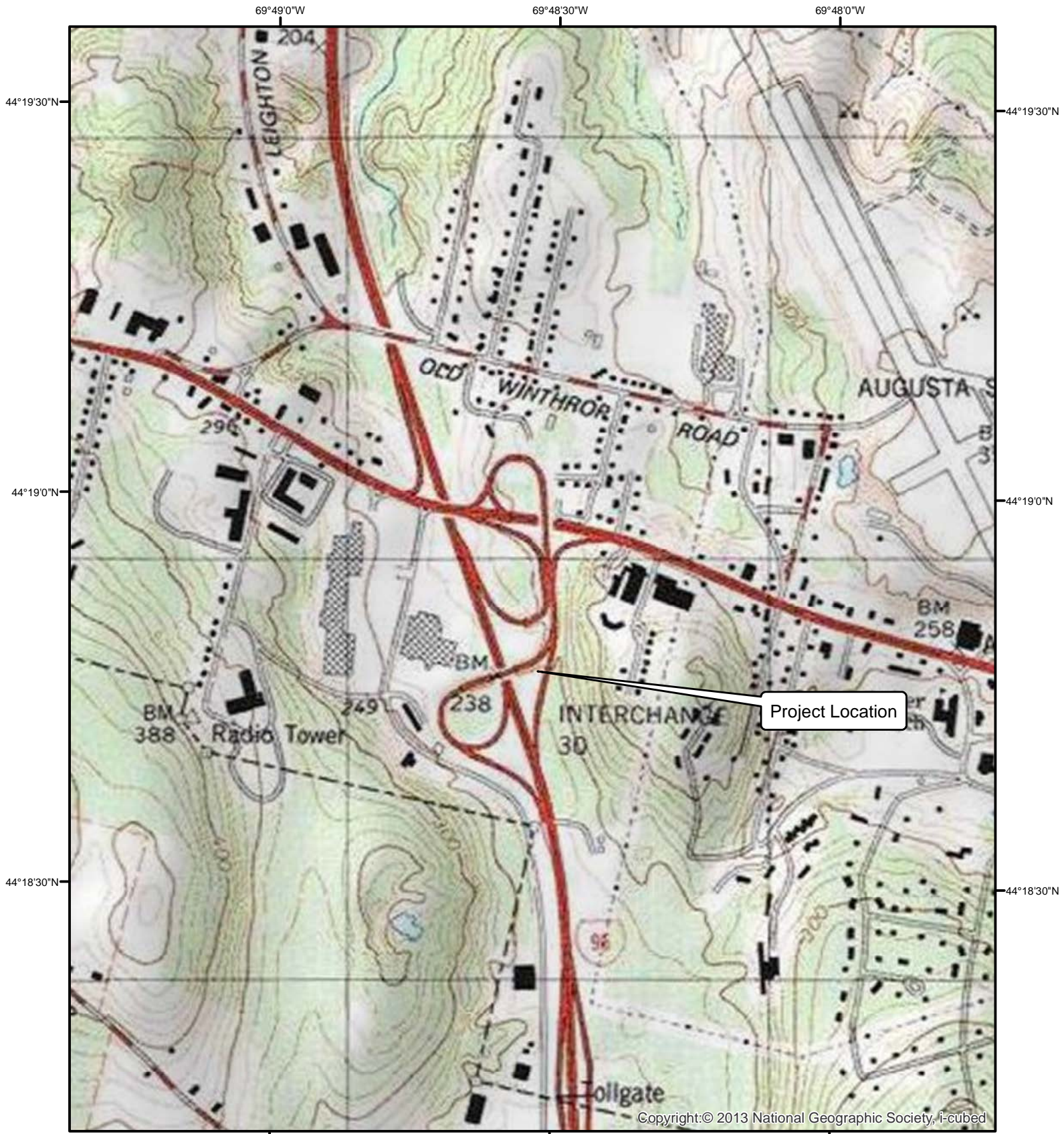

Interstate 95/Ramp F improvements
 WIN 23444.00
 Augusta, ME (Kennebec County)
 Augusta, ME USGS Quad map
 44.312990 x -69.809085

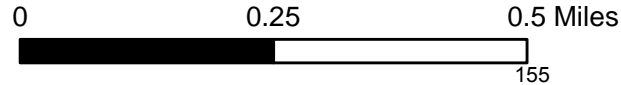

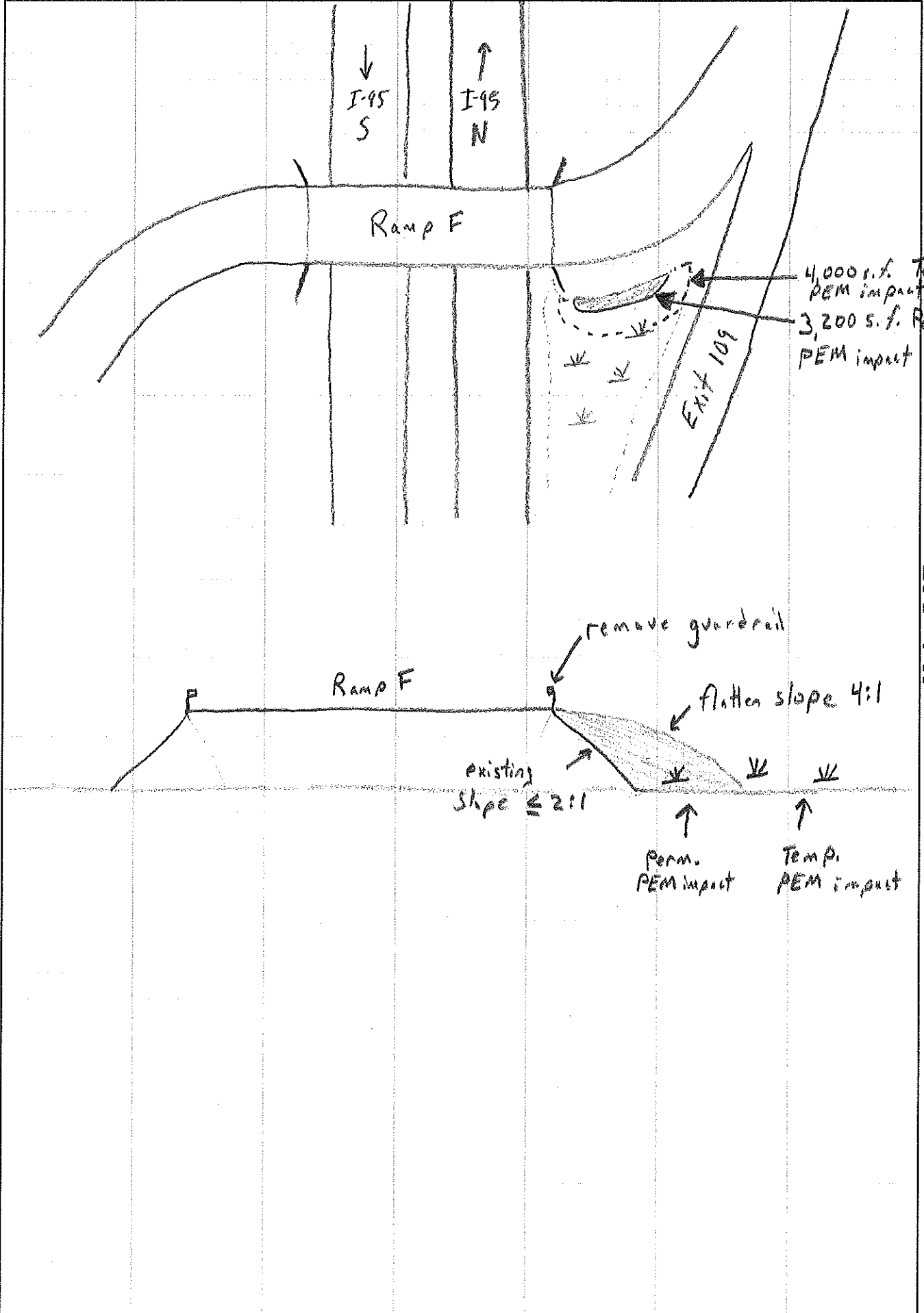

**DEPARTMENT OF THE ARMY
GENERAL PERMIT FOR
THE STATE OF MAINE**

The New England District of the U.S. Army Corps of Engineers (Corps) hereby issues a General Permit (GP) for activities subject to Corps jurisdiction in waters of the U.S. within the boundaries of the State of Maine. This GP is issued in accordance with Corps regulations at 33 CFR 320 - 332 [see 33 CFR 325.2(e)(2)]. This GP authorizes activity-specific categories of work that are similar in nature and cause no more than minimal individual and cumulative adverse environmental impacts. Refer to Page 2 for the list of activities and Appendix A for activity specific conditions of eligibility in inland and tidal waters.

I. GENERAL CRITERIA

1. In order for activities to qualify for this GP, they must meet the GP's terms and eligibility criteria (Pages 1–4), General Conditions (GC) (Pages 5 – 20), and Appendix A - Definition of Categories.
2. Under this GP, projects may qualify for the following:
 - Category 1: Category 1 Self -Verification Notification Form is required (SVNF – see Appendix B).
 - Category 2: Application to and written approval from the Corps is required (Pre-Construction Notification (PCN)). No work may proceed until written approval from the Corps is received.

If your project is ineligible for Category 1, it may qualify for Category 2 or an Individual Permit and you must submit an application (see Page 3). The thresholds for activities eligible for Categories 1 and 2 are defined in Appendix A. This GP does not affect the Corps Individual Permit review process or activities exempt from Corps regulation.

3. Prospective permittees need to read:
 - a. Section II to determine if the activity requires Corps authorization.
 - b. Sections III and IV to determine if the activity may be eligible for authorization under this GP, specifically whether it is eligible for Self-Verification (SV) or whether Pre-Construction Notification (PCN) is required.
4. Permittees must ensure compliance with all applicable General Conditions in Section IV. The Corps will consider unauthorized any activity requiring Corps authorization if that activity is under construction or completed and does not comply with all of the terms and conditions.
5. Project proponents are encouraged to contact the Corps with questions at any time. Pre-application meetings (see 33 CFR 325.1(b)), whether arranged by the Corps or requested by permit applicants, are encouraged to facilitate the review of projects. Pre-application meetings and/or site visits can help streamline the permit process by alerting the applicant to potentially time-consuming concerns that are likely to arise during the evaluation of their project (e.g., avoidance, minimization and compensatory mitigation requirements, historic properties, endangered species, essential fish habitat, and dredging contaminated sediments).

II. CORPS JURISDICTION/ACTIVITIES COVERED

1. Permits are required from the Corps of Engineers for the following work:
 - a. The construction of any structure in, over or under any navigable water of the United States (U.S.)¹, the excavating or dredging from or depositing of material in such waters, or the accomplishment of any other work affecting the course, location, condition, or capacity of such waters. The Corps regulates these activities under Section 10 of the Rivers and Harbors Act of 1899. See 33 CFR 322;
 - b. The discharge of dredged or fill material and certain discharges associated with excavation into waters of the U.S. (e.g. sidcasting). The Corps regulates these activities under Section 404 of the Clean Water Act (CWA). See 33 CFR 323; and
 - c. The transportation of dredged material for the purpose of disposal in the ocean. The Corps regulates these activities under Section 103 of the Marine Protection, Research and Sanctuaries Act. See 33 CFR 324.
2. Related laws:

33 CFR 320.3 includes a list of related laws, including: Section 401 of the CWA, Section 402 of the CWA, Section 307(c) of the Coastal Zone Management (CZM) Act of 1972, The National Historic Preservation Act of 1966, the Endangered Species Act, the Fish and Wildlife Act of 1956, the Marine Mammal Protection Act of 1972, Magnuson-Stevens Act, and Section 7(a) of the Wild and Scenic Rivers Act.
3. An activity listed below may be authorized by this GP only if that activity and the permittee satisfy all of the GP's terms and conditions. Any activity not specifically listed below may still be eligible for the GP; applicants are advised to contact the Corps for a specific eligibility determination. Category 1 and Category 2 eligibility criteria for each activity in both Inland and Tidal waters can be found in Appendix A.

1. Repair, Replacement, Expansion, and Maintenance of Authorized Structures and Fills
2. Moorings
3. Structures, Floats and Lifts
4. Aids to Navigation, and Temporary Recreational Structures
5. Dredging, Disposal of Dredged Material, Beach Nourishment, and Rock Removal and Relocation
6. Discharges of Dredged or Fill Material Incidental to the Construction of Bridges
7. Bank and Shoreline Stabilization
8. Residential, Commercial, Industrial, and Institutional Developments, and Recreational Facilities
9. Utility Line Activities
10. Linear Transportation Projects
11. Mining Activities
12. Boat Ramps and Marine Railways
13. Land and Water-Based Renewable Energy Generation Facilities and Hydropower Projects
14. Reshaping Existing Drainage Ditches and Mosquito Management
15. Oil Spill and Hazardous Material Cleanup
16. Cleanup of Hazardous and Toxic Waste
17. Scientific Measurement Devices
18. Survey Activities
19. Agricultural Activities
20. Fish and Wildlife Harvesting, Enhancement, and Attraction Devices
21. Habitat Restoration, Establishment and Enhancement Activities
22. Previously Authorized Activities
23. Stream & Wetland Crossings
24. Aquaculture

Note: Multiple activities may be authorized in the same GP, e.g. a recreational pier (#3) with an associated mooring (#2) or a windpower facility (#13) with an associated transmission line (#9).

¹ Defined in Appendix F, Definitions and at 33 CFR 328.
Section II

III. PROCEDURES

1. State Approvals. Applicants are responsible for applying for and obtaining any of the required state or local approvals. Federal and state jurisdictions may differ in some instances. State permits may be required for specific projects regardless of the general permit category.

In order for authorizations under this GP to be valid, when any of the following state approvals or statutorily-required reviews is also required, the approvals must be obtained prior to the commencement of work in Corps jurisdiction.

- Maine Department of Environmental Protection (DEP): Natural Resources Protection Act (NRPA) permit, including permit-by-rule (PBR) and general permit authorizations; Site Location of Development Act permit; Maine Waterway Development and Conservation Act permit; and Maine Hazardous Waste, Septage, and Solid Waste Management Act license.
- Maine Department of Conservation, Agriculture & Forestry: Land Use Planning Commission (LUPC) permit.
- Maine Department of Marine Resources: Aquaculture Leases.
- Maine Department of Conservation, Bureau of Parks and Lands, Submerged Lands: Submerged Lands Lease.

NOTE: This GP may also be used to authorize projects that are not regulated by the State of Maine (e.g., certain seasonal floats or moorings).

2. How to Obtain/Apply for Authorization.

a. Category 1 (**Self-Verification**): Self-Verification Notification Form (SVNF) required. The SVNF is required for all SV eligible work in Maine unless otherwise stated in Appendix A. Activities that are eligible for SV are authorized under this GP and may commence without written verification from the Corps provided the prospective permittee has:

i. Confirmed that the activity will meet the terms and conditions of Category 1. Consultation with the Corps and/or other relevant federal and state agencies may be necessary to ensure compliance with the applicable general conditions (GCs) and related federal laws such as the National Historic Preservation Act (see GC 6), the Endangered Species Act (GC 8) and the Wild and Scenic Rivers Act (GC 9). Prospective permittees are encouraged to contact the Corps with SV eligibility questions. Activities not meeting the SV criteria must submit a PCN to the Corps.

ii. Submitted the SVNF (see GC 27 and Appendix B) to the Corps. **NOTE: A copy of a state permit application form may be an acceptable surrogate for the SVNF. Whichever form chosen needs to include a location map, plans, and an Official Species List for federally listed threatened or endangered species (Reference Appendix D).**

b. Category 2 (**Pre-Construction Notification (PCN)**): Application to and written verification from the Corps is required before work can proceed. For activities that do not qualify for SV or where otherwise required by the terms of the GP, the permittee must submit a PCN and obtain a written permit before starting work in Corps jurisdiction.

i. The Corps will coordinate review of all activities requiring PCN with federal and state agencies and federally recognized tribes, as appropriate. To be eligible and subsequently authorized, an activity must result in no more than minimal individual and cumulative effects on the aquatic environment as determined by the Corps in accordance with the criteria listed within this GP. This may require project modifications involving avoidance, minimization, or compensatory mitigation for unavoidable impacts to ensure that the net adverse effects of a project are no more than minimal.

ii. The Corps will attempt to issue a written eligibility determination within the state's review period. Regardless, work eligible for Category 2 may not proceed before Corps written approval is received.

c. All applicants for Category 2 projects must:

- i. Apply directly to the Corps using the state application form or the Corps application form (ENG Form 4345²), and apply directly to the state (DEP, LUPC, BPL or DMR) as applicable using the appropriate state form, if the work is regulated by the Corps and the state; or
 - ii. Apply directly to the Corps using the Corps application form (ENG Form 4345²) if the work is regulated by the Corps but not the state (DEP, LUPC, BPL or DMR).
 - iii. Provide application information (see “Information Typically Required” in Appendix C) to help ensure the application is complete and to speed project review.
 - iv. Obtain an Official Species List of federally threatened or endangered species in the project area (GC 8).
 - v. Submit a copy of their application materials to the Maine Historic Preservation Commission (MHPC) *and all five Indian tribes* listed at Appendix E, at the same time, or before, they apply to the Corps, to be reviewed for the presence of historic, archaeological or tribal resources in the permit area that the proposed work may affect. Submittals to the Corps shall include information to indicate that this has been done (a copy of the applicant’s cover letter to MHPC and tribes or a copy of the MHPC and tribal response letters is acceptable).
- d. Work that is not regulated by the State of Maine, but is subject to Corps jurisdiction, may still be eligible for authorization under this GP.

e. Emergency Situations: 33 CFR 325.2(e)4 states that an “emergency” is a situation which would result in an unacceptable hazard to life, a significant loss of property, or an immediate, unforeseen, and significant economic hardship if corrective action requiring a permit is not undertaken within a time period less than the normal time needed to process the application under standard procedures.” Emergency work is subject to the same terms and conditions of this GP as non-emergency work, and similarly, must qualify for authorization under the GP; otherwise an IP is required. The Corps will work with all applicable agencies to expedite verification according to established procedures in emergency situations.

3. Individual Permits. Projects that are not authorized by this GP require an Individual Permit (IP) (33 CFR 325.5) and proponents must submit an application directly to the Corps. This GP does not affect the Corps IP review process or activities exempt from Corps regulation. For general information and application form, see the Corps website or contact the Corps (see Appendix E). The Corps encourages applicants to apply concurrently for a Corps IP and applicable state permits.

The Corps retains discretionary authority on a case-by-case basis to elevate a GP eligible project to an IP based on concerns for the aquatic environment or for any other factor of the public interest [33 CFR 320.4(a)]. Whenever the Corps notifies an applicant that an IP is required, no work in Corps jurisdiction may be conducted until the Corps issues the required authorization in writing indicating that work may proceed.

4. Enforcement/Non-Compliance. Work performed without the required Corps of Engineers permits is subject to administrative, civil, and criminal penalties. The Corps will evaluate unauthorized activities for enforcement action under 33 CFR 326.

The Corps will consider unauthorized any activity requiring Corps authorization if that activity is under construction or completed and does not comply with all of the terms and conditions of a GP or an IP. The Corps may elect to suspend enforcement proceedings if the permittee modifies his project to comply with a GP.

After considering whether a violation was knowing or intentional, and other indications of the need for a penalty, the Corps can elect to terminate an enforcement proceeding with an after-the- fact authorization under a GP, if all terms and conditions of the GP have been satisfied, either before or after the activity has been accomplished.

² Located at www.nae.usace.army.mil/missions/regulatory under “Forms & Publications.”
Section III

IV. GENERAL CONDITIONS

To qualify for GP authorization, the prospective permittee must comply with the following general conditions, as applicable.

1. Other Permits
2. Federal Jurisdictional Boundaries
3. Minimal Direct, Secondary, and Cumulative Impacts
4. Mitigation (Avoidance, Minimization, and Compensatory Mitigation)
5. Single and Complete Projects
6. Historic Properties
7. Corps Projects and Property
8. Federal Threatened and Endangered Species
9. Wild and Scenic Rivers
10. Navigation
11. Federal Liability
12. Utility Line Installation and Removal
13. Heavy Equipment in Wetlands or Mudflats
14. Temporary Fill
15. Restoration of Special Aquatic Sites (including wetland areas).
16. Soil Erosion, Sediment and Turbidity Controls
17. Time of Year Windows/Restrictions.
18. Aquatic Life Movements & Management of Water Flows
19. Water Quality and Coastal Zone Management
20. Floodplains and Floodways
21. Storage of Seasonal Structures
22. Spawning, Breeding, and Migratory Areas
23. Vernal Pools
24. Invasive and Other Unacceptable Species
25. Programmatic Agreements
26. Permit On-Site
27. Self-Verification Notification Form (SVNF)
28. Inspections
29. Maintenance
30. Property Rights
31. Transfer of GP Verifications
32. Modification, Suspension, and Revocation
33. Special Conditions
34. False or Incomplete Information
35. Abandonment
36. Enforcement Cases
37. Duration of Authorization
38. Previously Authorized Activities
39. Discretionary Authority
40. St. John/St. Croix Rivers.
41. National Lands
42. Essential Fish Habitat (EFH)
43. Work Site Restoration
44. Bank Stabilization
45. Stream Work & Crossings and Wetland Crossings

1. Other Permits. Permittees must obtain other federal, state, or local authorizations required by law. Applicants are responsible for applying for and obtaining all required state or local approvals. This includes, but is not limited to, the project proponent obtaining a Flood Hazard Development Permit issued by the town, if necessary. Inquiries may be directed to the municipality or to the Maine Floodplain Management Coordinator at (207) 287-8063. See <http://www.maine.gov/dacf/flood/>

2. Federal Jurisdictional Boundaries

a. Applicability of this GP shall be evaluated with reference to federal jurisdictional boundaries. Applicants are responsible for ensuring that the boundaries used satisfy the federal criteria defined at 33 CFR 328 “Waters of the U.S.” and 33 CFR 329 “Navigable Waters of the U.S.”

NOTE: Waters of the U.S. include the subcategories “navigable waters of the U.S.” and “wetlands.”

b. For Category 1 projects, proponents are not required to delineate the waters of the U.S. that they plan to impact, but must approximate the square footage of impacts in order to determine the review category (1 or 2 or Individual Permit). For projects filling <15,000 square feet (SF) of waters of the U.S. that do not qualify for Category 1 (e.g., vernal pool, secondary or endangered species impacts, etc.) and therefore require an application to the Corps (PCN), and for those filling ≥15,000 SF, applicants shall delineate all waters of the U.S. that will be filled (direct impacts) in accordance with the Corps of Engineers Wetlands Delineation Manual and the most recent regional supplement (see Appendix C). In addition, applicants shall approximately identify all waters of the U.S. on the property and *known* waters adjacent to the property in order for the Corps to evaluate secondary impacts. The waters of the U.S. shall be clearly shown on the project plans submitted with the application. This includes all waters of the U.S. in areas under DEP or LUPC jurisdiction regardless of whether they’re shown on LUPC zoning maps.

c. On a case-by-case basis, the Corps may modify/refine the above delineation and identification requirements for waters of the U.S. See www.nae.usace.army.mil/missions/regulatory >> Jurisdictional Limits and Wetlands for more information on delineating jurisdictional areas.

3. Minimal Direct, Secondary, and Cumulative Effects³

a. Projects authorized by this GP shall have no more than minimal direct, secondary and cumulative adverse environmental impacts. Category 2 applicants should provide information on secondary and cumulative impacts as stated in Appendix C. Compensatory mitigation may be required to offset unavoidable impacts (see GC 4) and to ensure that they are no more than minimal. Compensatory mitigation requirements will be determined on a case-by-case basis.

b. Secondary impacts to waterway and/or wetland areas, (e.g., areas drained, flooded, cleared, excavated or fragmented) shall be added to the total fill area when determining whether the project qualifies for Category 1 or 2. Direct, secondary and cumulative impacts are defined at Appendix A, Endnote 2 and Appendix F.

c. Site clearing, grading and construction activities in the upland habitat surrounding vernal pools (“Vernal Pool Management Areas”) are secondary impacts. See GC 23 for avoidance and minimization requirements and recommendations.

d. Bank stabilization activities in tidal waters are provided at Appendix A, Page 30. Direct impacts in tidal waters from contiguous bank stabilization projects in excess of 200 linear feet (Applicant or Applicant + Abutters combined) must undergo Category 2 review.

4. Mitigation (Avoidance, Minimization, and Compensatory Mitigation)

a. Discharges of dredged or fill material into waters of the U.S., including wetlands, shall be avoided and minimized to the maximum extent practicable through consideration of alternatives. The Corps may require compensatory mitigation of unavoidable direct and secondary impacts associated with Category 2 projects on a case-by-case basis.

b. Applicants proposing work in jurisdictional waters should consider riparian/forested buffers for stormwater management and low impact development (LID) best management practices (BMPs) to reduce

³ Direct, secondary and cumulative effects are defined at Appendix F, Definitions and Acronyms.

impervious cover and manage stormwater to minimize secondary impacts to aquatic resources to the maximum extent practicable.⁴

c. Compensatory mitigation⁵ for effects to waters of the U.S., including direct, secondary and temporal⁶, may be required for permanent impacts that exceed the SV area limits, and may be required for temporary impacts that exceed the SV area limits, to offset unavoidable impacts which remain after all appropriate and practicable avoidance and minimization has been achieved and to ensure that the adverse effects to the aquatic environment are no more than minimal. Proactive restoration projects or temporary impact work with no lasting secondary effects may generally be excluded from this requirement. Refer to Appendix G.

5. Single and Complete Projects⁷

a. This GP shall not be used to piecemeal work and shall be applied to single and complete projects. When determining the review category in Appendix A (Category 1 or 2) for a single and complete project, proponents must include any permanent historic fill placed since October 1995 that is associated with that project and all currently proposed temporary and permanent impact areas.

b. A single and complete project must have independent utility⁷.

c. Unless the Corps determines the activity has independent utility:

i. This GP shall not be used for any activity that is part of an overall project for which an Individual Permit is required.

ii. All components of a single project and/or all planned phases of a multi-phased project (e.g., subdivisions should include all work such as roads, utilities, and lot development) shall be treated together as constituting one single and complete project.

d. For linear projects, such as power lines or pipelines with multiple crossings, the single and complete project is all crossings of a single water of the U.S. (i.e., single waterbody) at a specific location. For linear projects crossing a single waterbody several times at separate and distant locations, each crossing is considered a single and complete project. However, individual channels in a braided stream or river, or individual arms of a large, irregularly-shaped wetland or lake, etc., are not separate waterbodies and crossings of such features cannot be considered separately. If any crossing requires a Category 2 activity, then the entire linear project shall be reviewed as one project under Category 2.

6. Historic Properties

a. No undertaking shall cause effects (defined at 33 CFR 325 Appendix C and 36 CFR 800) on properties listed on, determined to be eligible for listing on, or potentially eligible for listing on the National Register of Historic Places⁸, including previously unknown historic properties within the permit area, unless the Corps or another Federal action agency has satisfied the consultation requirements of Section 106 of the National Historic Preservation Act (NHPA). The State Historic Preservation Officer (SHPO), Tribal Historic Preservation Officer (THPO) and the National Register of Historic Places can assist with locating information on: i) previously identified historic properties; and ii) areas with potential for the presence of historic resources, which may require identification and evaluation by qualified historic preservation and/or archaeological consultants in consultation with the Corps and the SHPO and/or THPO(s).

⁴ See: www.nae.usace.army.mil/missions/regulatory >> State General Permit >> Permit Resources >> Mitigation for this additional information: a) "Wetland BMP Manual - Techniques for Avoidance & Minimization," b) riparian/forested buffer BMPs, and c) LID BMPs. LID BMPs include, but are not limited to: replacing curbs and gutters with swales; using an open space design for subdivisions; using permeable, pervious or porous pavements; constructing bio-retention systems; and/or, adding a green roof or rain garden.

⁵ Compensatory mitigation projects provided to offset losses of aquatic resources must comply with the applicable provisions of 33 CFR 332. See also the New England District Compensatory Mitigation Guidance at www.nae.usace.army.mil/regulatory >> Mitigation.

⁶ Temporal loss: The time lag between the loss of aquatic resource functions caused by the permitted impacts and the replacement of aquatic resource functions at the compensatory mitigation site(s) (33 CFR 332.2).

⁷ Single and Complete Project and Independent Utility are defined in Appendix F - Definitions.

⁸ The majority of historic properties are not listed on the National Register of Historic Places and may require identification and evaluation by qualified historic preservation and/or archaeological consultants in consultation with the Corps and the SHPO and/or THPO(s).

b. For activities eligible for SV, proponents must ensure and document that the activity will not cause effects as stated in 6(a). Proponents must submit a PCN if the authorized activity may cause effects as stated in 6(a) as soon as possible to ensure that the Corps is aware of any potential effects of the permitted activity on any historic property to ensure all Section 106 requirements are met.

c. All PCNs shall: i) show notification to the SHPO and applicable THPO(s)⁹ for their identification of historic properties, ii) state which historic properties may be affected by the proposed work or include a vicinity map indicating the location of the historic properties or the potential for the presence of historic properties, and iii) include any available documentation from the SHPO or THPO(s) indicating that there are or are not historic properties affected. Starting consultation early in project planning can save proponents time and money.

d. If you discover any previously unknown historic, cultural or archeological remains and artifacts while accomplishing the activity authorized by this permit, you must immediately notify the district engineer of what you have found, and to the maximum extent practicable, avoid construction activities that may affect the remains and artifacts until the required coordination has been completed. The district engineer will initiate the Federal, Tribal and state coordination required to determine if the items or remains warrant a recovery effort or if the site is eligible for listing in the National Register of Historic Places.

7. Corps Projects and Property

a. In addition to any authorization under this GP, proponents must contact the Corps Real Estate Division at (978) 318-8585 for work occurring on or potentially affecting Corps properties and/or Corps-controlled easements to initiate reviews and determine what real estate instruments are necessary to perform work. Permittees may not commence work on Corps properties and/or Corps-controlled easements until they have received any required Corps real estate documents evidencing site-specific permission to work.

b. Any proposed temporary or permanent alteration, or modification or use, including occupation, of a federal project (including but not limited to a levee, dike, floodwall, channel, anchorage, breakwater, seawall, bulkhead, jetty, wharf, pier or other work built but not necessarily owned by the United States), which would obstruct or impair the usefulness of the federal project in any manner, and/or would involve changes to the authorized federal project's scope, purpose, and/or functioning that go beyond minor modifications required for normal operations and maintenance, is not eligible for SV and requires review and approval by the Corps pursuant to 33 USC 408. Where Section 408 is applicable, a decision on a Department of the Army general permit application will not be rendered prior to the decision on a Section 408 request.

c. Any structure or work within any Corps Federal Navigation Project (FNP) or its buffer zone¹⁰, shall be subject to removal at the owner's expense prior to any future Corps dredging or the performance of periodic hydrographic surveys. See GC 10 for more requirements related to FNPs.

8. Federal Threatened and Endangered Species

a. No activity is authorized which: i) is likely to directly or indirectly jeopardize the continued existence of a threatened or endangered species or a species proposed for such designation, as identified under the Federal Endangered Species Act (ESA), or which will directly or indirectly destroy or adversely modify the critical habitat of such species; ii) "may affect" a listed species or critical habitat, unless Section 7 consultation addressing the effects of the proposed activity has been completed; or iii) violates the ESA.

b. **All applicants must request an Official Species List from the US Fish & Wildlife Service and must include the list in the Corps permit application. To request an Official Species List, refer to the instructions in Appendix D.**

c. **For federally listed species in tidal waters, applicants should contact the National Marine Fisheries Service at: <http://www.greateratlantic.fisheries.noaa.gov/protected/section7/>**

⁹ Appendix E, 3(a)&(b). Historic Resources, provides contact information and each tribe's "area of concern."

¹⁰ See Appendix H for a list of FNPs. The buffer zone is equal to three times the authorized depth of the FNP.

d. A PCN is required if a threatened or endangered species, a species proposed for listing as threatened or endangered, or designated or proposed critical habitat (all hereinafter referred to as “listed species or habitat”), as identified under the ESA, is present in the action area¹¹.

e. Federal agencies should follow their own procedures for complying with the requirements of the ESA but should coordinate that consultation with the Corps as well.

9. Wild and Scenic Rivers.¹² Any activity that occurs in the designated main stem of, within 0.25 mile up or downstream of the designated main stem of, or in tributaries within .25 miles of the designated main stem of a National Wild and Scenic River, or in “bordering and contiguous wetlands” (see Appendix A, Endnote 1) that are adjacent to the designated main stem of a National Wild and Scenic River, or that has the potential to alter flows within a river within the National Wild and Scenic River System, is not eligible for Category 1 regardless of size of the impacts. This condition applies to both designated Wild and Scenic Rivers and rivers officially designated by Congress as study rivers for possible inclusion while such rivers are in an official study status. National Wild and Scenic Rivers System segments for Maine as of October 2015 include: Allagash River beginning at Telos Dam continuing to Allagash checkpoint at Eliza Hole Rapids, approximately 3 miles upstream of the confluence with the St. John River (length = 92 miles); and 11.25 miles of the York River, in the State of Maine, from its headwaters at York Pond to the mouth of the river at York Harbor, plus its tributaries (currently under study).

10. Navigation

a. Any structure or work that extends closer to the horizontal limits of any Corps Federal Navigation Project (see Appendix H) than a distance of three times the project’s authorized depth shall be subject to removal at the owner’s expense prior to any future Corps dredging or the performance of periodic hydrographic surveys. This is applicable to Category 1 and 2. Reference Appendix A, Page 28 (Moorings) and Page 29 (Structures, Floats & Lifts).

b. There shall be no unreasonable interference with navigation by the existence or use of the activity authorized herein, and no attempt shall be made by the permittee to prevent the full and free use by the public of all navigable waters at or adjacent to the activity authorized herein.

c. The permittee understands and agrees that if future U.S. operations require the removal, relocation, or other alteration of the structure or work herein authorized, or if, in the opinion of the Secretary of the Army or his authorized representative, said structure or work shall cause unreasonable obstruction to the free navigation of the navigable waters, the permittee will be required, upon due notice from the Corps, to remove, relocate, or alter the structural work or obstructions caused thereby, without expense to the U.S. No claim shall be made against the U.S. on account of any such removal or alteration.

d. A PCN is required for all work in, over or under an FNP or its buffer zone unless otherwise indicated in Appendix A. (Reference Appendix A, Endnote 13, Page 36)

11. Federal Liability. In issuing this permit, the Federal Government does not assume any liability for the following: (a) damages to the permitted project or uses thereof as a result of other permitted or unpermitted activities or from natural causes; (b) damages to the permitted project or uses thereof as a result of current or future activities undertaken by or on behalf of the U.S. in the public interest; (c) damages to persons, property, or to other permitted or unpermitted activities or structures caused by the activity authorized by this permit; (d) design or construction deficiencies associated with the permitted work; (e) damage claims associated with any future modification, suspension, or revocation of this permit.

12. Utility Line Installation and Removal

a. Subsurface utility lines shall remain subsurface. If it is necessary to discharge dredged or filled material not previously authorized in order to keep such utility lines buried or restore them to their original subsurface condition, a PCN and written verification from the Corps may be required (e.g., in the case of side

¹¹ The “Endangered Species Consultation Handbook – Procedures for Conducting Consultation and Conference Activities Under Section 7 of the ESA,” defines action area as “all areas to be affected directly or indirectly by the Federal action and not merely the immediate area involved in the action. [50 CFR 402.02].”

¹² Additional information can be found at: <http://www.rivers.gov>.

casting into wetlands from utility trenches). Certain repair, replacement or maintenance activities may be eligible for Category 1 – refer to Appendix A.

b. Subsurface utility lines must be installed at a sufficient depth to avoid damage from anchors, dredging, etc., and to prevent exposure from erosion and stream adjustment. In accordance with Corps New England District Regulation NEDER 1110-1-9 (www.nae.usace.army.mil/missions/regulatory >> [Useful Links and Documents](#)), as an absolute minimum, the bottom cover associated with the initial installation of utility lines under navigable waters and navigation channels shall be 48 inches in soil or 24 inches in rock excavation in competent rock unless specified in a written determination. These minimum bottom cover requirements for pipelines and cables shall be measured from the maximum depth of dredging to the top of the utility. The maximum depth of dredging, in waterways having existing FNPs, is generally considered to be the authorized project depth plus any allowance for advanced maintenance and the allowable overdepth for dredging tolerances. In waterways that do not have existing FNPs, this depth should be taken as two feet below the existing bottom or maximum depth of proposed dredging, as applicable.

c. Aerial utility lines that cross navigable waters must meet minimum clearances. See 33CFR322.5(i).

d. For horizontal directional drilling work, returns of drilling fluids to the surface (i.e., frac-outs) are not authorized and require restoration to the maximum extent practicable in accordance with the terms and conditions of this GP. The permittee and its contractor shall have onsite and shall implement the procedures detailed in a frac-out contingency plan for monitoring drilling operations and for the immediate containment, control and recovery/removal of drilling fluids released into the environment should a discharge of material occur during drilling operations.

e. Within the context of any new installations, any abandoned or inactive utility lines should be removed and faulty lines (e.g., leaking hazardous substances, petroleum products, etc.) should be removed or repaired to the extent practicable. A PCN and written verification from the Corps is required if they are to remain in place, e.g., to protect sensitive areas or ensure safety.

f. No work shall drain a water of the U.S. by providing a conduit for water on or below the surface. Trench plugs installed along pipelines may be effective.

13. Heavy Equipment in Wetlands or Mudflats. Operating heavy equipment other than fixed equipment (drill rigs, fixed cranes, etc.) within wetlands shall be minimized, and such equipment shall not be stored, maintained or repaired in wetlands, to the maximum extent practicable. Where construction requires heavy equipment operation in wetlands, the equipment shall either have low ground pressure (typically <3 psi), or it shall be placed on swamp/construction/timber mats (herein referred to as “construction mats” and defined at Appendix A, Endnote 4) that are adequate to support the equipment in such a way as to minimize disturbance of wetland soil and vegetation. Construction mats are to be placed in the wetland from the upland or from equipment positioned on swamp mats if working within a wetland. Dragging construction mats into position is prohibited. Other support structures that are capable of safely supporting equipment may be used with written Corps authorization (Category 2 authorization or Individual Permit). Similarly, the permittee may request written authorization from the Corps to waive use of mats during frozen, dry or other conditions. An adequate supply of spill containment equipment shall be maintained on site. Construction mats should be managed in accordance with the Construction Mat BMPs at www.nae.usace.army.mil/missions/regulatory >> State General Permits >> Permit Resources.

14. Temporary Fill. Temporary fill that qualifies for Category 1 (e.g., <15,000 SF of combined temporary and permanent fill associated with the single and complete project) or is authorized in writing under Category 2, shall adhere to the following:

a. All temporary fill and disturbed soils shall be stabilized to prevent its eroding into waters of the U.S. where it is not authorized. Work shall include phased or staged development to ensure only areas under active development are exposed and to allow for stabilization practices as soon as practicable, typically within three calendar days after disturbance. Accelerated stabilization (the providing of temporary or permanent cover by the end of the work day to prevent erosion) shall be employed as necessary. Temporary fill must be placed in a manner that will prevent it from being eroded by expected high flows.

b. Unconfined temporary fill authorized for discharge into waters of the U.S. (e.g., temporary stream crossings) shall consist of material that minimizes impacts to water quality (e.g. washed stone, stone, etc.).

c. Appropriate measures must be taken to maintain normal downstream flows and minimize flooding to the maximum extent practicable when temporary structures, work, and discharges of dredged or fill material, including cofferdams, are necessary for construction activities, access fills, or dewatering of construction sites. Place materials in a location and manner that does not adversely impact surface or subsurface water flow into or out of the wetland. Temporary fill authorized for discharge into wetlands shall be placed on geotextile fabric or other appropriate material laid on the pre-construction wetland grade where practicable to minimize impacts and to facilitate restoration to the original grade. Construction mats are excluded from this requirement.

d. Temporary fill, construction mats and corduroy roads shall be entirely removed as soon as they are no longer needed to construct the authorized work. Temporary fill shall be placed in its original location or disposed of at an upland site and suitably contained to prevent its subsequent erosion into waters of the U.S. To qualify for Category 1, temporary fill placed during the: i.) growing season must be removed before the beginning of the next growing season; and ii.) non-growing season may remain throughout the following growing season, but must be removed before the beginning of the next growing season.

e. Temporary fill, construction mats and corduroy roads are considered temporary only if they are removed as soon as they are no longer needed to construct the authorized work.

f. Construction debris and/or deteriorated materials shall not be located in waters of the U.S.

15. Restoration of Special Aquatic Sites (Including Wetland Areas)

a. Temporary fills must be removed in their entirety and the affected areas restored to their pre-construction condition, function and elevation. Restoration shall typically commence no later than the completion of construction.

b. For excavated areas, “restored to pre-construction condition, function and elevation” means careful removal of existing soil and vegetation, separate topsoil and subsoil stockpiling, soil protection, and replacement back to the original location such that the original soil layering and vegetation schemes are approximately the same, unless otherwise authorized. Plan for natural settling that will occur (the initial post-restoration elevation of the backfilled areas should be above the desired final grade as topsoil may settle by 33% to 50%), minimize compaction, and ensure that topsoil is void of gravel and subsoil. A minimum of 4 inches of topsoil should be at the surface after the soil has settled. Wetland areas temporarily disturbed shall be stabilized (e.g., seeded or planted). Seed mixes and vegetation shall include only plant species native to New England and shall not include any species listed as “Invasive and Other Unacceptable Plant Species” in the “New England District Compensatory Mitigation Guidance” (see GC 24 and refer to Appendix G). This list may be updated periodically.

c. Limit compaction to the minimum needed to promote a successful seedbed; avoid a ‘fluffy’ seedbed, which is susceptible to erosion until the plants get established, and a compacted topsoil layer, which is counter-productive and will lead to greater erosion susceptibility down the road. Test soils for compaction. A soil probe, auger, or shovel should be able to retrieve samples of post-restoration profile. Equipment refusal shall be considered a failure of restoration, in which case the soil should be restored through deep-ripping and/or de-compaction, or other appropriate methods, and wetland hydrology must be maintained. See the BMPs at www.nae.usace.army.mil/missions/regulatory >> State General Permits >> Permit Resources >> Restoration.

d. In areas of authorized temporary disturbance, cut woody vegetation (trees, shrubs, etc.) shall be cut at or above ground level and not uprooted in order to prevent disruption to the wetland soil structure and to allow stump sprouts to revegetate the work area, unless otherwise authorized.

e. Trenches shall be constructed or backfilled so that the trench does not drain waters of the U.S. (e.g., materials or methods that create a French drain effect).

16. Soil Erosion, Sediment and Turbidity Controls

a. Adequate sedimentation and erosion control management measures, practices and devices, such as phased construction, installation of sediment control barriers (i.e. silt fence, vegetated filter strips, geotextile silt fences, erosion control mixes, hay bales or other devices) downhill of all exposed areas, retention of existing vegetated buffers, application of temporary mulching during construction, and permanent seeding and stabilization shall be installed and properly maintained to reduce erosion and retain sediment on-site during and after construction. They shall be capable of preventing erosion; of collecting sediment, suspended and floating materials; and of filtering fine sediment.

- b. Temporary sediment control barriers shall be removed upon completion of work, but not until all disturbed areas are permanently stabilized. The sediment collected by these sediment barriers shall be removed and placed at an upland location and stabilized to prevent its later erosion into a waterway or wetland.
- c. All exposed soil and other fills shall be permanently stabilized at the earliest practicable date .

17. Time of Year Work Windows/Restrictions. For activities where work is authorized in streams and tidal waters that causes turbidity or sediment re-suspension or other construction related disturbances, work must be conducted during the following TOY work windows (not during the TOY restrictions) unless otherwise authorized by the Corps under Category 2 review:

	<u>TOY Restriction</u> (no work)	<u>TOY Work Window</u> (work allowed)
Non-tidal waters	Oct. 01 through Jul. 14	Jul. 15 through Sep. 30
Tidal waters	Apr. 10 through Nov. 07	Nov. 08 through Apr. 09

Alternate windows authorized under Category 2 may include species specific windows recommended by the Maine Dept. of Marine Resources and/or Maine Dept. of Inland Fisheries & Wildlife.

18. Aquatic Life Movements & Management of Water Flows

a. No activity may substantially disrupt the necessary life cycle movements of those species of aquatic life indigenous to the waterbody, including those species that normally migrate through the area, unless the activity’s primary purpose is to impound water. Unless otherwise stated, activities impounding water in a stream require a PCN to ensure impacts to aquatic life species are avoided and minimized. All permanent and temporary crossings of waterbodies (e.g., streams, wetlands) shall be:

- i. Suitably culverted, bridged, or otherwise designed and constructed to maintain low flows to sustain the movement of those aquatic species; and
- ii. Properly aligned and constructed to prevent bank erosion or streambed scour both adjacent to and inside the culvert. Permanent and temporary crossings of wetlands shall be suitably culverted, spanned or bridged in such a manner as to preserve hydraulic and ecological connectivity between the wetlands on either side of the road.

b. To avoid adverse impacts on aquatic organisms, the low flow channel/thalweg shall remain unobstructed during periods of low flow, except when it is necessary to perform the authorized work.

c. To the maximum extent practicable, the pre-construction course, condition, capacity, and location of open waters must be maintained for each activity, including stream channelization and storm water management activities. The activity must be constructed to withstand expected high flows. The activity must not restrict or impede the passage of normal or high flows, unless the primary purpose of the activity is to impound water or manage high flows. The activity may alter the preconstruction course, condition, capacity, and location of open waters if it benefits the aquatic environment (e.g., stream restoration or relocation activities).

19. Water Quality and Coastal Zone Management

a. Applicants must satisfy any conditions imposed by the state and EPA, where applicable, in their CWA § 401 Water Quality Certifications (WQC) for this GP, or in any Individual § 401 WQC. See Appendix E for state-specific contact information and to determine if any action is required to obtain a 401 WQC. The Corps may require additional water quality management measures to ensure that the authorized activity does not cause or contribute to a violation of water quality standards. All projects authorized by this GP shall be designed, constructed and operated to minimize or eliminate the discharge of pollutants.

b. Applicants must satisfy any additional conditions imposed by the state in their Coastal Zone Management (CZM) Act consistency concurrences for this GP, or in any Individual CZM consistency concurrences. The Corps may require additional measures to ensure that the authorized activity is consistent with state coastal zone management requirements.

20. Floodplains and Floodways

a. Appropriate measures must be taken to minimize flooding to the maximum extent practicable.

b. Activities within 100-Year Floodplains must comply with applicable Federal Emergency Management Agency (FEMA)-approved state and/or local floodplain management permitting requirements. Proponents may need to coordinate with FEMA and apply for a formal change to the flood insurance study products or forward a set of project plans and relevant technical documentation in a digital format to the Risk

Analysis Branch Chief, Mitigation Division, FEMA, Region 1, 99 High Street, Boston, Massachusetts 02110. Applicants should provide a copy of any documentation to the Corps along with the PCN.

c. Proponents may have to obtain a Flood Hazard Development Permit issued by the town. Inquiries may be directed to the municipality or to the Maine Floodplain Management Coordinator at (207) 287-8063. See <http://www.maine.gov/dacf/flood/>

21. Storage of Seasonal Structures. Seasonal or recreational structures such as pier sections, floats, aquaculture structures, etc. that are removed from the waterway for a portion of the year (often referred to as seasonal structures) shall be stored in an upland location landward of mean high water (MHW) or ordinary high water (OHW) and not in wetlands, tidal wetlands, their substrate or on mudflats. These seasonal structures may be stored on the fixed, pile-supported portion of the structure that is waterward of MHW or OHW. Seasonal storage of structures in navigable waters, e.g., in a protected cove on a mooring, requires Corps approval and local harbormaster approval.

22. Spawning, Breeding, and Migratory Areas

a. Jurisdictional activities and impacts such as excavations, discharges of dredged or fill material, and/or suspended sediment producing activities in jurisdictional waters that provide value as fish migratory areas, fish and shellfish spawning or nursery areas, or amphibian and migratory bird breeding areas, during spawning or breeding seasons shall be avoided and minimized to the maximum extent practicable.

b. Jurisdictional activities in waters of the United States that provide value as breeding areas for migratory birds must be avoided to the maximum extent practicable. The permittee is responsible for obtaining any “take” permits required under the USFWS’s regulations governing compliance with the Migratory Bird Treaty Act or the Bald and Golden Eagle Protection Act. The permittee should contact the appropriate local office of the USFWS to determine if such “take” permits are required for a particular activity (See Appendix E).

23. Vernal Pools

a. Only vernal pools that meet the current definition of waters of the U.S. are regulated by the Corps.

b. Direct and indirect adverse effects to all vernal pools (VPs), including their envelopes and critical terrestrial habitats (VP Management Areas¹³), shall be avoided and minimized to the maximum extent practicable. Site clearing, grading, and construction activities associated with a regulated activity in the VP Management Area may cause these adverse effects to the VP.

c. The State of Maine has specific protections for vernal pools.¹⁴

d. When any regulated activities occur within 750 feet of a vernal pool, the following management practices must be followed for all work within any VP Management Area (750’ of a VP’s edge) *in order to qualify for Category I*:

- i. No disturbance within the VP Depression or VP Envelope (area within 100 feet of the VP Depression’s edge)¹⁵;
- ii. Maintain a minimum of 75% of the Critical Terrestrial Habitat (area within 100-750 feet of the VP Depression’s edge) as unfragmented forest with at least a partly-closed canopy of overstory trees to provide shade, deep litter and woody debris;
- iii. Maintain or restore forest corridors connecting wetlands and significant vernal pools;
- iv. Minimize forest floor disturbance; and
- v. Maintain native understory vegetation and downed woody debris.

¹³ The Corps VP Management Area, which includes the VP and a 750’ radius from the VP’s edge, is defined at Appendix A, Endnote 5.

¹⁴ Appendix G, 10(a)-(d) provides links to the state’s Significant Wildlife Habitat regulations and references that provide impact minimization measures to reference when designing projects.

¹⁵ The no disturbance requirement in the VP envelope [see (b)(i)(1)], and (b)(i)(2), do not apply to temporary impacts associated with construction mats in previously disturbed areas of existing utility project (e.g., transmission lines, gas pipelines) or linear transportation project (e.g., roads, highways, railways, trails, airport runways and taxiways) right-of-ways provided there is a Vegetation Management Plan that avoids, minimizes and mitigates impacts to aquatic resources.

vi. Cape Cod style-curbings or no curbings options shall be used on new roads to facilitate amphibian passage. (Reference Appendix G)

e. A PCN is required for any regulated activity within 750' of a vernal pool when all work within the VP Management Area does not comply with the Category 1 requirements in (d) above. Information on directional buffers in accordance with the VP Directional Buffer Guidance document may be provided in order to demonstrate minimal impact and avoid compensation requirements (Reference Appendix G). Conservation of the un-impacted area within the VP Management Area will often be required.

f. GC 2 requires applicants to delineate or approximately identify on the project plans all waters of the U.S., which contain vernal pools.

g. GC 23(b-d) do not apply to projects that are within a municipality and meet the provisions of a Corps-approved VP Special Area Management Plan (VP SAMP) and are otherwise eligible for self-verification.

24. Invasive and Other Unacceptable Species¹⁶

a. The introduction or spread of invasive or other unacceptable plant or animal species on the project site or areas adjacent to the project site caused by the site work shall be avoided to the maximum extent practicable. For example, construction mats and equipment shall be thoroughly cleaned and free of vegetation and soil before and after use. The introduction or spread of invasive plant or animal species on the project site caused by the site work shall be controlled.

b. No cultivars, invasive or other unacceptable plant species may be used for any mitigation, bioengineering, vegetative bank stabilization or any other work authorized by this GP. However, non-native species and cultivars may be used when it is appropriate and specified in a written verification, such as using *Secale cereale* (Annual Rye) to quickly stabilize a site. All PCNs should explain the reason for using non-native species or cultivars.

25. Programmatic Consultations or Agreements. The Corps requirements to comply with Section 106 of the NHPA, Section 7 of the Endangered Species Act or Essential Fish Habitat conservation under the Magnuson-Stevens Act may be satisfied by a Programmatic Agreement with the Corps, New England District or another federal action agency. Any Corps, New England District Programmatic Agreements will be available on our website.

26. Permit On Site. The permittee shall ensure that a copy of this GP and any accompanying authorization letter with attached plans are at the site of the work authorized by this GP whenever work is being performed and that all construction personnel performing work which may affect waters of the U.S. are aware of its terms and conditions. The entire permit authorization shall be made a part of any and all contracts and subcontracts for work that affects areas of Corps jurisdiction at the site of the work authorized by this GP. This shall be achieved by including the entire permit authorization in the specifications for work. The term "entire permit authorization" means this entire GP and the authorization letter (including its drawings, plans, appendices and other attachments) and also includes permit modifications. If the authorization letter is issued after the construction specifications, but before receipt of bids or quotes, the entire permit authorization shall be included as an addendum to the specifications. If the authorization letter is issued after receipt of bids or quotes, the entire permit authorization shall be included in the contract or subcontract. Although the permittee may assign various aspects of the work to different contractors or subcontractors, all contractors and subcontractors shall be obligated by contract to comply with all environmental protection provisions contained within the entire GP authorization, and no contract or subcontract shall require or allow unauthorized work in areas of Corps jurisdiction.

¹⁶ For the purposes of this GP, plant species that are considered invasive and unacceptable are provided in Appendix G "Invasive and other Unacceptable Plant Species" of our document "Compensatory Mitigation Guidance" at www.nae.usace.army.mil/missions/regulatory >> Mitigation. Chapter 4(e) Planting is also particularly relevant. The June 2009 "Corps of Engineers Invasive Species Policy" provides policy, goals and objectives and is located at www.nae.usace.army.mil/missions/regulatory >> Invasive Species. Additional information can be found at: www.eddmaps.org/ipane.

27. Self-Verification Notification Form (SVNF). Permittees must complete and submit the SVNF provided at Appendix B to the Corps for work authorized by this GP unless otherwise noted in Appendix A. **NOTE: A copy of a state permit application form may be an acceptable surrogate for the SVNF provided either form used also include plans and an Official Species List of federally listed threatened or endangered species.**

28. Inspections. The permittee shall allow the Corps to inspect the authorized activity at any time deemed necessary to ensure that it is being or has been accomplished in accordance with the terms and conditions of this GP and any written verification. The Corps may also require post-construction engineering drawings for completed work, post-dredging survey drawings for any dredging work, or other post-construction reports. To facilitate these inspections, the permittee shall complete and return to the Corps the following forms:

- For Category 1/Self-Verification: The SVNF (see Appendix B).
- For Category 2/PCN: The a) Work-Start Notification Form and b) Compliance Certification Form, when either is provided with the authorization letter.

29. Maintenance

a. Any authorized structure or fill shall be properly maintained, including maintenance to ensure public safety and compliance with applicable general conditions and activity-specific conditions to a written verification.

b. The requirement in (a) above does not include maintenance of dredging projects. Each maintenance dredging event exceeding the self-verification limits requires a new PCN unless an unexpired, written PCN or other Corps authorization specifies that the permittee may “dredge and maintain” an area for a particular time period. Self-verification or PCN maintenance dredging includes only those areas and depths previously authorized and actually dredged. Maintenance dredging with ocean or open water disposal will always require a PCN and at least Category 2 review.

c. Some maintenance activities may not be subject to regulation under Section 404 in accordance with 33 CFR 323.4(a)(2). Refer to Appendix A, Endnote 7.

30. Property Rights. This GP does not convey any property rights, either in real estate or material, or any exclusive privileges, nor does it authorize any injury to property or invasion of rights or any infringement of federal, state, or local laws or regulations.

31. Transfer of GP Verifications. When the structures or work authorized by this GP are still in existence at the time the property is transferred, the terms and conditions of this GP, including any special conditions, will continue to be binding on the entity or individual who received the GP authorizations, as well as the new owner(s) of the property. If the permittee sells the property associated with a GP verification, the permittee may transfer the GP verification to the new owner by submitting a letter to the Corps (see Appendix E for address) to validate the transfer. A copy of the GP verification must be attached to the letter, and *the letter must contain the new owner’s contact information and the following statement and signature:*

“When the structures or work authorized by this GP are still in existence at the time the property is transferred, the terms and conditions of this GP, including any special conditions, will continue to be binding on the new owner(s) of the property. To validate the transfer of this GP and the associated liabilities associated with compliance with its terms and conditions, have the transferee sign and date below.”

(Transferee)

(Date)

32. Modification, Suspension, and Revocation. Any work authorized under this GP by self-verification or PCN may be either modified, suspended, or revoked, in whole or in part, pursuant to the policies and procedures of 33 CFR 325.7. Any such action shall not be the basis for any claim for damages against the U.S.

33. Special Conditions. The Corps may independently, or at the request of the federal resource agencies, impose other special conditions on a project authorized pursuant to this GP that are determined necessary to minimize adverse navigational and/or environmental effects or based on any other factor of the public interest. Failure to comply with all terms and conditions of the authorization, including special conditions, constitutes a permit violation and may subject the permittee to criminal, civil or administrative penalties and/or an ordered restoration.

34. False or Incomplete Information. If the Corps makes a determination regarding the eligibility of a project under this GP and subsequently discovers that it has relied on false, incomplete or inaccurate information provided by the permittee, the Corps may determine that the GP authorization is not valid; modify, suspend or revoke the authorization; and the U.S. Government may institute legal proceedings.

35. Abandonment. If the permittee decides to abandon the activity authorized under this GP, unless such abandonment is merely the transfer of property to a third party, he/she may be required to restore the area to the satisfaction of the Corps.

36. Enforcement cases. This GP does not apply to any existing or proposed activity in Corps jurisdiction associated with an ongoing Corps or EPA enforcement action, until such time as the enforcement action is resolved or the Corps or EPA, as appropriate, determines that the activity may proceed independently without compromising the enforcement action.

37. Duration of Authorization. This GP expires on October 12, 2020. Activities authorized under this GP that have commenced (i.e., are under construction) or are under contract to commence before this GP expires will have until October 12, 2021 to complete the activity under the terms and conditions of the current GP.

38. Previously Authorized Activities.

a. Projects that have received authorization (Category 1 or 2) from the Corps and that were completed under the previous PGPs, nationwide permits, regional general permits or letters of permission, shall remain authorized.

b. Activities authorized pursuant to 33 CFR Part 330.3 (“Activities occurring before certain dates”) are not affected by this GP.

c. Any work not commenced nor completed that was authorized in a written letter from the Corps under the GP in effect between October 12, 2010 and October 12, 2015 remains authorized subject to the terms and general conditions of this GP along with any special conditions in the authorizing written letter. Exception – if previously authorized work is not commenced and a new federally listed threatened or endangered species could be affected, the Corps must consult with the Service(s) prior to re-authorizing the work under this GP. Requests for re-authorization must include an updated Official Species list. To request an Official Species List, refer to the instructions in Appendix D.

39. Discretionary Authority. Notwithstanding compliance with the terms and conditions of this permit, the Corps retains discretionary authority to require Category 2 or Individual Permit review based on concerns for the aquatic environment or for any other factor of the public interest [33 CFR 320.4(a)]. This authority is invoked on a case-by-case basis whenever the Corps determines that the potential consequences of the proposal warrant a higher level of review based on the concerns stated above. This authority may be invoked for projects that may contribute to cumulative environmental impacts that are more than minimal or if there is a special resource or concern associated with a particular project that is not already covered by the remaining conditions of the GP and that warrants greater review. Whenever the Corps notifies an applicant that an Individual Permit may be required, the project is not authorized under this GP and no work may be conducted until an Individual Permit is obtained or until the Corps notifies the applicant that further review has demonstrated that the work may proceed under this GP.

40. St. John/St. Croix Rivers. Work within the Saint John and Saint Croix River basins that requires approval of the International Joint Commission is not eligible for Category 1 and a PCN to the Corps is required if any temporary or permanent use, obstruction or diversion of international boundary waters could affect the natural

flow or levels of waters on the Canadian side of the line; or if any construction or maintenance of remedial works, protective works, dams, or other obstructions in waters downstream from boundary waters could raise the natural level of water on the Canadian side of the boundary.

41. National Lands. Activities that impinge upon the value of any National Wildlife Refuge, National Forest, National Marine Sanctuary, National Park or any other area administered by the National Park Service, U.S. Fish and Wildlife Service (USFWS) or U.S. Forest Service are not eligible for Category 1 and require a PCN.

42. Essential Fish Habitat (EFH). Any work in the following rivers and streams, including all tributaries to the extent that they are currently or were historically accessible for salmon migration, shall not be authorized under Category 1 of the GP and must be screened for potential impacts to EFH (see Appendix G for more information).

Androscoggin River	Aroostook River	Boyden River	Dennys River
Ducktrap River	East Machias River	Hobart Stream	Kennebec River
Machias River	Narraguagus River	Orland River	Passagassawaukeag River
Patten Stream	Penobscot River	Pleasant River	Presumpscot River
Saco River	Sheepscot River	St. Croix River	Tunk Stream
			Union River

The above does not apply to the following activities which may qualify for Category 1 work:

- Exploratory drilling and borings for bridges.
- Moorings (see Appendix A, Page 28 for Category 1 thresholds and requirements)
- Structures, floats & lifts (see Appendix A, Page 29 for Category 1 thresholds and requirements)
- Other activities specified in a programmatic agreement with NMFS.

43. Work Site Restoration

a. Wetland areas where permanent disturbance is not authorized shall be restored to their original condition and elevation, which under no circumstances shall be higher than the pre-construction elevation. Original condition means careful protection and/or removal of existing soil and vegetation, and replacement back to the original location such that the original soil layering and vegetation schemes are approximately the same, unless otherwise authorized.

b. Upon completion of construction, all disturbed wetland areas (the disturbance of these areas must be authorized) shall be properly stabilized. Any seed mix shall contain only plant species native to New England and shall not contain any species listed in the “Invasive and Other Unacceptable Plant Species” Appendix in the “New England District Compensatory Mitigation Guidance” (see GC 24 and refer to Appendix G). This list may be updated periodically.

c. In areas of authorized temporary disturbance, if trees are cut they shall be cut at ground level and not uprooted in order to prevent disruption to the wetland soil structure and to allow stump sprouts to revegetate the work area, unless otherwise authorized.

44. Bank Stabilization

a. Projects involving construction or reconstruction/maintenance of bank stabilization structures within Corps jurisdiction shall be designed to minimize environmental effects, effects to neighboring properties, scour, etc. to the maximum extent practicable.

b. Project proponents must design and construct bank stabilization projects using this sequential minimization process: avoidance of aquatic resource impacts, diversion of overland flow, vegetative stabilization, stone-sloped surfaces, and walls/bulkheads. Vertical walls/bulkheads shall only be used in situations where reflected wave energy can be tolerated.

c. Inland Water bank stabilization activities necessary for erosion prevention must meet all of the following criteria: i) No material is placed in excess of the minimum needed for erosion protection; ii) The activity is no more than 500 feet in total length along the bank(s); iii) The activity will not exceed an average of one cubic yard per running foot placed along the bank below the plane of the ordinary high water mark; iv) Structures angled steeper than 1H:1V and any material other than angular or sub-angular stone or fiber roll revetments require at least a Category 2 review; v) The activity does not involve discharges of dredged or fill

material into special aquatic sites; vi) No material is of the type, or is placed in any location, or in any manner, to impair surface water flow into or out of any water of the U.S.; vii) No material is placed in a manner that will be eroded by normal or expected high flows (properly anchored trees and treetops may be used in low energy areas); and viii) The activity is not a stream channelization activity.

d. Bank stabilization activities in tidal waters are provided at Appendix A, Page 30 & 31. Direct impacts in tidal waters from contiguous bank stabilization projects in excess of 200 linear feet (Applicant or Applicant + Abutters combined) must undergo Category 2 review.

45. Stream Work and Crossings & Wetland Crossings

Notes:

a. For *Stream Work and Crossings* below, conditions (a) and (b) apply to Inland Waters and Wetlands (see Appendix A, Page 1 for definition) and Navigable Waters (see Appendix A, Page 27 for definition). Conditions (c)-(l) below only apply to Inland Waters and Wetlands that are streams. All new and replacement crossings in Navigable Waters require an application to the Corps and at least a Category 2 review.

b. In-stream work in a watershed occupied by listed Atlantic salmon, Atlantic sturgeon, or shortnose sturgeon [see GC 8(b)] and some stream work such as crossings on EFH waters (see GC 42) is not eligible for Category 1.

c. “High-Quality Stream Segments” are shown at www.maine.gov/dep/gis/datamaps and may be useful in evaluating impacts to fisheries. GIS shape files are under “Other Google Earth Interactive Maps” and PDFs by county are under “DEP GIS Maps.” See Appendix E for more state contact information.

Conditions for Stream Work and Crossings:

a. All permanent crossings of rivers, streams, brooks, etc. (hereon referred to as “streams”) shall be suitably culverted, bridged, or otherwise designed to i) withstand and to prevent the restriction of high flows to qualify for Category 1, and ii) not obstruct the movement of or not substantially disrupt the necessary life-cycle movements of those species of aquatic life indigenous to the waterbody, including those species that normally migrate through the area, beyond the actual duration of construction unless the activity’s primary purpose is to impound water to qualify for Category 1 or 2. (*NOTE: Areas of fill and/or cofferdams must be included in total waterway/wetlands impacts to determine applicability of this GP.*)

b. Any work that temporarily or permanently impacts upstream or downstream flood conditions, or permanently impacts wetlands in excess of Category 1 thresholds, must be reviewed at least under Category 2. See the documents referenced in Appendix G, 8(c) and (d) for guidance.

c. New Stream Crossings. For new stream crossings to qualify for Category 1:

i. Must ensure compliance with GC 45(a) and GC 45(b) above.

ii. Shall be designed and constructed in accordance with the Corps General Stream Crossing

Standards provided on Page 19 and the stream simulation document listed at Appendix G, 8(a).

d. Replacement Stream Crossings. For replacement stream crossings to qualify for Category 1:

i. Must ensure compliance with GC 45(a) and GC 45(b) above.

ii. Shall be designed and constructed in accordance with the Corps General Stream Crossing

Standards provided on Page 19 and the stream simulation document listed at Appendix G, 8(a).

e. Culvert Extensions. Culvert extensions on culverts that do not meet the Corps General Stream Crossing Standards do not qualify for Category 1 and require an application to the Corps and at least Category 2 review.

f. Temporary Stream Crossings.

Note: The General Stream Crossing Standards don’t apply to temporary stream crossings.

i. Temporary stream crossings or cofferdams shall be used for equipment access across streams [see Appendix G, 8(e)]. Note: Areas of fill and/or cofferdams must be included in total waterway/wetlands impacts to determine the review category in Appendix A.

ii. Temporary stream crossings shall be removed within 180 days to qualify for Category 1.

iii. Temporary stream crossings that are not spans¹⁷ (typically culverts) must be designed in accordance with 1-6 below to qualify for Category 1. Category 2 applications should include information demonstrating 2-6 below:

1. Installed and removed during the low flow period specified in GC 45(l) below.
2. Placed on geotextile fabric or other material where practicable to ensure restoration to the original grade. Soil may not be used to construct or stabilize these structures and rock must be large enough to allow for easy removal without disrupting the streambed.
3. Designed and maintained to withstand and pass high flows. Water height should be no higher than the top of the culvert's inlet. A minimum culvert diameter of two feet is required to pass debris. Culverts must be aligned to prevent bank erosion or streambed scour.
4. Equipped with energy dissipating devices installed downstream if necessary to prevent scour.
5. Designed and maintained to prevent soil from entering the waterbody.
6. Removed upon the completion of work. Impacts to the streambed or banks requires restoration to their original condition using stream simulation methods¹⁸.

g. Slip Lining. Work using slip lining (retrofitting an existing culvert by inserting a smaller diameter pipe), invert lining, or resulting in decreased diameter, does not qualify for Category 1, either as new work or maintenance activities.

h. Work in Flowing Waters. To qualify for Category 1, no unconfined fill [see GC 14(b)] or excavation in flowing waters is allowed. To accomplish this:

i. Bank stabilization work below ordinary high water (OHW) shall utilize erosion controls such as inflatable cofferdams, jersey barrier, silt screen, turbidity curtain, etc. where practicable to prevent sediment input to the stream and to minimize turbidity and sedimentation impacts for sensitive life stages. Bank stabilization above OHW must utilize erosion controls.

ii. Management techniques such as temporary flume pipes, culverts, cofferdams, etc. must be used to maintain normal flows within the stream boundary's confines, or water diversions may be used immediately up and downstream of the work footprint (see Appendix A, Endnote 6) or work must be performed in the dry under no flow conditions, or under very low flow conditions following the practices in GC 45(a).

i. Minimization. In order to make the Category 2 review process more efficient and result in a faster decision, new and replacement stream crossings should be designed using the least intrusive and environmentally damaging method following this sequential minimization process: 1) spans with no stream impacts, 2) spans with stream impacts, and 3) embedded culverts with stream simulation or low-slope design.

j. Maintenance Requirements. The permittee shall maintain the work authorized herein in good condition and in conformance with the terms and general conditions of this permit to facilitate aquatic life passage as stated in GC 45(a). Culverts that develop "hanging" inlets or outlets, result in bed washout, or a stream that doesn't match the characteristics of the substrate in the natural stream channel such as mobility, slope, stability confinement will require maintenance or repair to comply with this GC. This does not apply to GC 45(f) above.

k. Maintenance and Replacement Information. An existing stream crossing must be authorized and in compliance with all conditions of its authorization(s) to qualify for maintenance not subject to regulation. See Appendix A, Endnote 7. A non-serviceable crossing is not eligible for maintenance and is therefore considered as a replacement crossing [see GC 45(d)].

l. Work Window. For projects that otherwise meet the terms of Category 1, in-stream construction work shall be conducted during the low flow period July 15 – September 30 in any year. Projects that are not to be conducted during that time period are ineligible for Category 1 and shall be screened pursuant to Category 2, regardless of the waterway and wetland fill and/or impact area.

Corps General Stream Crossing Standards (required for Category 1; recommended for Category 2):

- a. Culverts must be embedded:

¹⁷ For the purposes of this GP, spans are bridges, three-sided box culverts, open-bottom culverts or arches that span the stream with footings landward of bankfull width.

¹⁸ Design and construction shall be in accordance with the stream simulation document listed at Appendix G, 8(a).

- ≥ 2 feet for box culverts and other culverts with smooth internal walls,
- ≥ 1 foot for corrugated pipe arches
- ≥ 1 foot and at least 25 percent for corrugated round pipe culverts

b. **For new crossings**, spans¹⁷ are required to avoid or cause minimal disruption to the streambed and to meet the requirements of General Condition 45(a) and 45(b). Footings and abutments must be landward of 1.2 times bankfull width. To the greatest extent practicable, work in the stream shall be minimized, and design and construction shall allow the streambed's natural structure and integrity to remain intact. Any fill or excavation of the streambed below bankfull width other than footings, support pilings, or work specified in 45(h)ii requires Category 2 review and, unless demonstrated otherwise, stream simulation¹⁸ to establish substrate and banks in the span structure and work area as specified in (d) and (e) below.

c. **For replacement crossings**, spans¹⁷ are required to meet the requirements of General Condition 45(a) and 45(b). Footings and abutments shall be landward of 1.2 times bankfull width. Unless demonstrated otherwise, stream simulation¹⁸ is required to establish substrate and banks in the span structure and work area as specified in (d) and (e) below.

d. Crossings must have a natural bottom substrate within the structure matching the characteristics of the substrate in the natural stream channel and the banks (mobility, slope, stability, confinement, grain and rock size) at the time of construction and over time as the structure has had the opportunity to pass significant flood events. To allow terrestrial passage for wildlife and prevent undermining the footings, crossings shall have a bank on both sides of the stream matching the horizontal profile of the existing stream and banks¹⁸. Note: Installation of substrate material within smaller culverts may not be safe or practicable. In these cases, it may be necessary to allow for natural deposition and bed development unless alternative methods are identified.

e. Crossings must be designed and constructed¹⁸ with appropriate bed forms and streambed characteristics so that water depths and velocities are comparable to those found in the natural channel at a variety of flows. In order to provide appropriate water depths and velocities at a variety of flows and especially low flows, it is usually necessary to reconstruct the streambed or preserve the natural channel within the structure. Otherwise, the width of the structure needed to accommodate higher flows will create conditions that are too shallow at low flows. The grain and rock size, and arrangement of streambed materials within the structure should be in accordance with (d) above. Flows could go subsurface within the structure if only large material is used without smaller material filling the voids.

Conditions for Wetland Crossings:

a. All temporary and permanent crossings of wetlands shall be suitably culverted, bridged, or otherwise designed to: i) Withstand and prevent the restriction of high flows, ii) Not obstruct the movement of or not substantially disrupt the necessary life-cycle movements of those species of aquatic life indigenous to the wetland, including those species that normally migrate through the area, beyond the actual duration of construction unless the activity's primary purpose is to impound water. See Appendix E for the Maine DEP's crossing standards.

b. To qualify for Category 1, new and replacement wetland crossings that are permanent shall be culverted, spanned or bridged in such a manner as to preserve hydraulic and ecological connectivity, at its present level, between the wetlands on either side of the road. To meet this requirement, we recommend that culverts, spans or bridges be placed at least every 50 feet with an opening at least 2 feet high and 3 feet wide at ground level where practicable. Closed bottom culverts shall be embedded at least 6 inches with a natural bottom.

c. In the case of non-compliance, the permittee shall take necessary measures to correct wetland damage due to lack of hydraulic and ecological connectivity.

d. Any work that results in flooding, results in impacts to wetlands on either side of the wetland crossing in excess of Category 1 thresholds, or impacts wetland drainage from the upgradient side of the wetland crossing does not qualify for Category 1.



Robert J. Desista
Deputy Chief, Regulatory Division
For DISTRICT ENGINEER

DATE 10/13/15

APPENDIX A: DEFINITION OF CATEGORIES

<p>A. INLAND WATERS AND WETLANDS</p>	<p>Inland Waters and Wetlands: Waters that are regulated under Section 404 of the Clean Water Act, including rivers, streams, lakes, ponds and wetlands, and <i>excluding Section 10 Navigable Waters of the U.S. (tidal and freshwater)</i>. The jurisdictional limits are the ordinary high water (OHW) mark in the absence of adjacent wetlands, beyond the OHW mark to the limit of adjacent wetlands when adjacent wetlands are present, and the wetland limit when only wetlands are present. For the purposes of this GP and designated activities, fill placed in the area between the mean high water (MHW) and the high tide line (HTL), and in the bordering and contiguous wetlands¹ to tidal waters are reviewed in the Navigable Waters section. (See B. Navigable Waters on page 27 below.)</p> <p>Projects not meeting Category 1 require an application for review as a Category 2 or Individual Permit project.</p> <p>All Category 1 and 2 projects must comply with all of this GP's applicable terms (Pages 1 – 4) and General Conditions (Pages 5–20).</p>	
<p>ACTIVITY</p>	<p>CATEGORY 1 Self-Verification Eligible (SVNF Required)</p>	
<p>1. Repair, Replacement, and Expansion, and Maintenance of Authorized Structures and Fills</p>	<p>Repair or maintenance of existing, currently serviceable, authorized fills with no expansion or change in use:</p> <ul style="list-style-type: none"> • Conditions of the original authorization apply. • Minor deviations in fill design allowed.⁷ • The repair, rehabilitation, or replacement of those structures or fills destroyed or damaged by storms, floods, fire or other discrete events is authorized, provided the repair, rehabilitation, or replacement is commenced, or is under contract to commence, within two years of the date of their destruction or damage. • No effect on federally listed endangered or threatened species or critical habitat. 	<p>CATEGORY 2 (PCN Required)</p> <p>Replacement of non-serviceable fills, or repair/maintenance of serviceable fill, with expansion <3 acres, or with a change in use.</p>
<p>2. Moorings</p>	<p>NA – moorings in non-navigable inland waters are not subject to Corps jurisdiction.</p> <p>Note: Moorings placed in freshwater navigable waters are reviewed in the Navigable Waters section. (See B. Navigable Waters on Page 28 below.)</p>	<p>NA</p>
<p>3. Structures, Floats & Lifts</p>	<p>For solid fill or crib supported structures on inland waters, <15,000 square feet (SF) of waterway and/or wetland fill, associated secondary impacts², and temporary fills.</p> <ul style="list-style-type: none"> • No effect on federally listed endangered or threatened species or critical habitat. • Note: Temporary or permanent structures placed in freshwater navigable waters are reviewed in the Navigable Waters section. (See B. Navigable Waters on page 29 below.) 	<p>1. Work not eligible for Category 1</p> <p>2. ≥15,000 SF to <3 acres of inland waterway and/or wetland fill and associated secondary impacts (e.g., areas drained, flooded, fragmented, or excavated).</p>
<p>4. Aids to Navigation and Temporary Recreational Structures</p>	<p>NA - this activity in non-navigable inland waters is not subject to Corps jurisdiction.</p> <p>Note: Aids to Navigation and other structures placed in freshwater navigable waters are reviewed in the Navigable Waters section. (See B. Navigable Waters on page 30 below.)</p>	<p>NA</p>

<p>5. Dredging, Disposal of Dredged Material, Beach Nourishment, and Rock Removal and Relocation</p>	<p>1. For regulated discharges associated with excavation, and disposal <15,000 SF inland waterway and/or wetland impacts. 2. The activity does not occur in navigable waters of the U.S. 3. Stream channelization, relocation or loss of streambed including impoundments or discharge of tailings into streams does not occur. 4. No effect on federally listed endangered or threatened species or critical habitat.</p>	<p>1. Work not eligible for Category 1 2. ≥15,000 SF to <3 acres of inland waters.</p>
<p>6. Discharges of Dredged or Fill Material Incidental to the Construction of Bridges</p>	<p>NA - For discharges incidental to the construction of bridges in inland waters of the U.S. refer to Activity 23 (Stream and Wetland Crossings) and GC 45. Note: Discharges of Dredged or Fill Material Incidental to the Construction of Bridges in freshwater navigable waters are reviewed in the Navigable Waters section. (See B. Navigable Waters on page 30 below.)</p>	<p>NA</p>
<p>7. Bank and Shoreline Stabilization</p>	<p>Inland bank stabilization <500 FT long and ≤1 CY of fill per linear foot below OHW, provided:</p> <ul style="list-style-type: none"> • ≤1 cubic yard of fill per linear foot placed along the bank waterward of ordinary high water. • Work complies with the GCs (GC 44 in particular), including: <ul style="list-style-type: none"> o No structures angled steeper than 1H:1V allowed. Only rough-faced stone or fiber roll revetments allowed. o No in-stream work involving fill or excavation in flowing waters (see GC 45(h)). • In-water work limited to Jul 15 – Sep 30. • No work in vernal pools⁵ or SAS³. • No effect on federally listed endangered or threatened species or critical habitat. 	<p>Work not eligible for Category 1</p>
<p>8. Residential, Commercial, Industrial, and Institutional Developments, and Recreational Facilities</p>	<p>1. <15,000 SF of inland waterway and/or wetland fill and associated secondary impacts² (e.g., areas drained, flooded, fragmented, mechanically cleared or excavated). Fill area includes all temporary and permanent fill, and regulated discharges associated with excavation. Construction mats are considered as fill. [See GC 14] <u>Provided:</u></p> <ul style="list-style-type: none"> • Historic fill + proposed impact area <15,000 SF complies with GC 5, Single and Complete Projects. • No work in special aquatic sites (SAS)⁴ other than wetlands. • No effect on federally listed endangered or threatened species or critical habitat. <p>2. For work in Vernal Pool (VP) Management Areas (includes VPs)⁵:</p>	<p>1. Work not eligible for Category 1. 2. ≥15,000 SF to <3 acres of inland waterway and/or wetland fill and associated secondary impacts (e.g., areas drained, flooded, fragmented, or excavated). Fill area includes all temporary and permanent fill (including mats), and regulated discharges associated with excavation. 3. <i>Mechanical clearing without grubbing or other soil disturbance >3 acres as a secondary impact may still be eligible for Category 2 at the discretion of the Corps.</i></p> <p>See GC 2 and Appendix C for wetland delineation</p>

	<ul style="list-style-type: none"> • See GC 23 and Appendix C for VP delineation requirements. • See GC 23 to determine if work qualifies for Category 1 or 2. • See Appendix G for VP documents providing mitigation guidance. 	requirements.
<p>9. Utility Line Activities</p>	<ol style="list-style-type: none"> 1. <15,000 SF of inland waterway and/or wetland fill, associated secondary impacts², and temporary fills. 2. The activity does not occur in, over, or under navigable waters of the U.S. 3. Intake structures that are dry hydrants used exclusively for firefighting activities with no stream impoundments. 4. There is no permanent change in pre-construction contours in waters of the U.S. 5. Material resulting from trench excavation is temporarily side cast into waters of the U.S. for ≤3 months and is placed in such a manner that it is not dispersed by currents or other forces. 6. The utility line is placed within and does not run a) parallel to, or b) along a streambed. 7. Stream channelization, relocation or loss of streambed including impoundments does not occur. 8. No effect on federally listed endangered or threatened species or critical habitat. 9. There is no discharge in SAS other than non-tidal wetlands. 10. Construction mats⁴ of any area necessary to conduct activities that were previously authorized, authorized under Category 1, or not subject to regulation (see Endnote 7). Authorized construction mats must be in place for <3 months, removed immediately upon work completion, and the wetlands must be restored (see GC 43). 11. Stream crossings must comply with GC 17. 	<ol style="list-style-type: none"> 1. Work not eligible for Category 1 2. ≥15,000 SF to <3 acres of inland waterway and/or wetland fill and associated secondary impacts (e.g., areas drained, flooded, fragmented, or excavated). Fill area includes all temporary and permanent fill (including mats), and regulated discharges associated with excavation. 3. <i>Mechanical clearing without grubbing or other soil disturbance >3 acres as a secondary impact may still be eligible for Category 2 at the discretion of the Corps.</i>
<p>10. Linear Transportation Projects (not including stream crossings)</p> <p>For stream crossings, refer to Activity 23</p>	<ol style="list-style-type: none"> 1. <15,000 SF of inland waterway and/or wetland fill associated secondary impacts (e.g., areas drained, flooded, fragmented, mechanically cleared or excavated). Fill area includes all temporary and permanent fill, and regulated discharges associated with excavation. Construction mats are considered fill. (See GC 14.) Provided: <ul style="list-style-type: none"> • Historic fill + proposed impact area <15,000 SF and complies with GC 5 single and complete projects. • No work in special aquatic sites (SAS) other than wetlands. 2. Construction mats⁴ of any area necessary to conduct activities that were previously authorized, authorized under Category 1, or not subject to regulation (see Endnote 7). Authorized construction mats must be in place for <3 months, removed immediately upon work completion, and the wetlands must be restored (see GC 43). 3. No effect on federally listed endangered or threatened species or critical habitat. 	<ol style="list-style-type: none"> 1. ≥15,000 SF to <3 acres of inland waterway and/or wetland fill and associated secondary impacts (e.g., areas drained, flooded, fragmented, or excavated). Fill area includes all temporary and permanent fill (including mats), and regulated discharges associated with excavation. 2. <i>Mechanical clearing without grubbing or other soil disturbance >3 acres as a secondary impact may still be eligible for Category 2 at the discretion of the Corps.</i>

<p>11. Mining Activities</p>	<p>1. <15,000 SF of inland waterway and/or wetland fill, associated secondary impacts, and temporary impacts. 2. The activity does not occur in navigable waters of the U.S. 3. Stream channelization, relocation or loss of streambed including impoundments or discharge of tailings into streams does not occur. 4. No effect on federally listed endangered or threatened species or critical habitat.</p>	<p>1. Work not eligible for Category 1. 2. ≥15,000 SF to <3 acres of inland waterway and/or wetland fill and associated secondary impacts (e.g., areas drained, flooded, fragmented, or excavated). Fill area includes all temporary and permanent fill (including mats), and regulated discharges associated with excavation.</p>
<p>12. Boat Ramps</p>	<p>1. <15,000 SF of inland waterway and/or wetland fill, associated secondary impacts, and temporary impacts. 2. No effect on federally listed endangered or threatened species or critical habitat.</p>	<p>1. Work not eligible for Category 1 2. >15,000 SF and < 3 acres of impact.</p>
<p>13. Land and Water-Based Renewable Energy Generation Facilities and Hydropower Projects</p>	<p><i>For land-based facilities:</i> 1. <15,000 SF of inland waterway and/or wetland fill, associated secondary impacts, and temporary impacts. 2. Stream channelization, relocation or loss of streambed including impoundments does not occur. 3. No effect on federally listed endangered or threatened species or critical habitat. <i>For water-based facilities and hydropower projects:</i> No new facilities are eligible. Not Applicable</p>	<p><i>For land-based activities:</i> 1. Work not eligible for Category 1. 2. >15,000 SF and < 3 acres impact. 3. <i>Mechanical clearing without grubbing or other soil disturbance >3 acres as a secondary impact may still be eligible for Category 2 at the discretion of the Corps.</i> <i>For water-based facilities and hydropower projects:</i> > 3 acres of impact will require an IP.</p>
<p>14. Reshaping Existing Drainage Ditches & Mosquito Management</p>	<p>Not Applicable</p>	<p>Not Applicable</p>
<p>15. Oil Spill and Hazardous Material Cleanup</p>	<p>Jurisdictional activities required for the containment and cleanup of oil and hazardous substances that are subject to the National Oil and Hazardous Substances Pollution Contingency Plan (40 CFR 300) provided that the work is done in accordance with the Spill Control and Countermeasure Plan required by 40 CFR 112.3 or any existing state contingency plan and provided that the Regional Response Team (if one exists in the area) concurs with the proposed containment and cleanup action. SAS³ must typically be restored in place at the same elevation. <i>Note: SVNf or a surrogate state reporting form may be submitted after the fact.</i></p>	<p>Work not eligible for Category 1</p>

<p>16. Cleanup of Hazardous and toxic waste</p>	<p>Specific jurisdictional activities to effect the containment, stabilization, or removal of hazardous or toxic waste materials, including court ordered remedial action plans or related settlements, which are performed, ordered or sponsored by a government agency with established legal or regulatory authority. SAS should be restored in place at the same elevation.</p> <ul style="list-style-type: none"> • <15,000 SF of inland waterway and/or wetland fill, associated secondary impacts, and temporary impacts. • No stream channelization, relocation or loss of streambed occurs. • The project does not involve establishing new disposal sites or expanding existing sites used for the disposal of hazardous or toxic waste. • No effect on federally listed endangered or threatened species or critical habitat. 	<p>Work not eligible for Category 1</p>
<p>17. Scientific Measurements Devices</p>	<ol style="list-style-type: none"> 1. Scientific measurement devices whose purpose is to measure and record scientific data, such as staff gages, water recording devices, water quality testing and improvement devices, and similar structures. This excludes any biological sampling devices. Structures may not restrict or concentrate movement of aquatic organisms. 2. No effect on federally listed endangered or threatened species or critical habitat. 	<p>Work not eligible for Category 1</p>
<p>18. Survey Activities</p>	<ol style="list-style-type: none"> 1. Jurisdictional survey activities, such as core sampling, seismic exploratory operations, plugging of seismic shot holes and other exploratory-type bore holes, exploratory trenching, soil surveys, sampling, and historic resources surveys (but not recovery). Exploratory trenches must be restored in accordance with GC 43. The construction of temporary pads is authorized provided the discharge doesn't exceed 25 CY. This doesn't authorize permanent structures or the drilling and the discharge of excavated material from test wells for oil and gas exploration (the plugging of such wells is authorized). 2. No effect on federally listed endangered or threatened species or critical habitat. 	<p>Work not eligible for Category 1</p>
<p>19. Agricultural Activities</p>	<ol style="list-style-type: none"> 1. For those activities subject to Corps jurisdiction¹⁶, <15,000 SF of inland waterway and/or wetland fill, associated secondary impacts, and temporary impacts. 2. No stream channelization, relocation, loss of streambed, or farm ponds in streams. 3. No effect on federally listed endangered or threatened species or critical habitat. 	<ol style="list-style-type: none"> 1. ≥15,000 SF to <3 acres of inland waterway and/or wetland fill and associated secondary impacts (e.g., areas drained, flooded, fragmented, or excavated). Fill area includes all temporary and permanent fill (including mats), and regulated discharges associated with excavation. 2. > 3 acres of impact will require an IP.

<p>20. Fish and Wildlife Harvesting, Enhancement and Attraction Devices and Activities</p>	<p>NA - this activity in non-navigable inland waters, if not involving a discharge of dredged or fill material, is not subject to Corps jurisdiction. Note: Related structures placed in freshwater navigable waters (e.g. the upper Penobscot or Kennebec Rivers) are reviewed in the Navigable Waters section. (See B. Navigable Waters on Page 33 below.)</p>	<p>Not Applicable</p>
<p>21. Habitat Restoration, Establishment and Enhancement Activities</p>	<p>1. <15,000 SF of inland waterway and/or wetland fill, associated secondary impacts, and temporary impacts. 2. The activity is supported in writing by a local, state, or non-Corps Federal environmental agency. Water impoundments require PCN. 3. No conversion of i) a stream to wetland or vice versa, wetland to a pond or uplands, and ii) one wetland type to another. 4. No dam removal. 5. No effect on federally listed endangered or threatened species or critical habitat.</p>	<p>1. Work not eligible for Category 1 2. Aquatic habitat restoration, establishment, and enhancement of wetlands and riparian areas and the restoration and enhancement of streams and other open waters with impacts of any area \geq 15,000 SF, provided those activities result in net increase in overall aquatic resource functions and services.⁸</p>
<p>22. Previously Authorized Activities</p>	<p>Any work not commenced nor completed that was authorized in a written letter from the Corps under the GP in effect between October 12, 2010 and October 12, 2015. The terms and general conditions of this GP apply along with any special conditions in the written authorization.</p>	
<p>23. Stream & Wetland Crossings</p>	<p>1. River, stream and brook work and crossings: <ul style="list-style-type: none"> • Must comply with GC 45 in particular, including: <ul style="list-style-type: none"> o No slip lining [see GC 45 (g)]. o No in-stream work involving fill or excavation in flowing waters [see GC 45(h)]. o In-stream work limited to Jul 15 – Sep 30 [see GC 45 (l)]. • No work in riffles and pools³. • No stream relocations. • No dams or dikes⁶. • No effect on federally listed endangered or threatened species or critical habitat. • <15,000 SF of inland waterway and/or wetland fill, associated secondary impacts, and temporary impacts. <p>2. Wetland crossings must comply with the particularly relevant GC 45.</p> </p>	<p>Work not eligible for Category 1</p>
<p>24. Aquaculture (freshwater)</p>	<p>For land based installations, <15,000 SF of inland waterway and/or wetland fill, associated secondary impacts, and temporary impacts. <ul style="list-style-type: none"> • In-stream/in-water work limited to Jul 15 – Sep 30. • No effect on federally listed endangered or threatened species or critical habitat. <p>Note: Related structures placed in freshwater navigable waters are reviewed in the Navigable Waters section. (See B. Navigable Waters, below.)</p> </p>	<p>Work not eligible for Category 1</p>

<p>B. NAVIGABLE WATERS</p>	<p>Navigable Waters of the United States: Waters that are subject to the ebb and flow of the tide and/or the tidal and non-tidal portions of the Federally designated navigable waters (the Penobscot River, Kennebec River, and Lake Umbagog) (Section 10 Rivers and Harbors Act of 1899). The jurisdictional limits are the mean high water (MHW) line in tidal waters and the ordinary high water (OHW) mark in non-tidal portions of the federally designated navigable rivers. For the purposes of this GP, fill placed in the area between the mean high water (MHW) and the high tide line (HTL), and in the bordering and contiguous wetlands¹ to tidal waters are also reviewed in this Navigable Waters section.</p> <p>Projects not meeting Category 1 require an application for review as a Category 2 or Individual Permit project. All Category 1 and 2 projects must comply with all of this GP's applicable terms (Pages 1 - 4) and General Conditions (Pages 5 - 20).</p>
<p>ACTIVITY</p>	<p>CATEGORY 1 Self-Verification Eligible (SVNF Required)</p>
<p>1. Repair, Replacement, and Expansion of Maintenance of Authorized (or Grandfathered) Structures and Fills</p>	<p>CATEGORY 2 (PCN Required)</p> <p>1. Replacement of non-serviceable structures and fills or repair/maintenance of serviceable structures or fills, with fill, replacement or expansion <1 acre, or with a change in use.</p> <p>2. <1 acre temporary or permanent fill, excavation and/or secondary impacts. Fill area includes all temporary and permanent waterway fills, provided:</p> <ul style="list-style-type: none"> • Temporary or permanent fill in eelgrass¹⁴ <1000 SF. • Permanent fill in SAS (excluding eelgrass¹⁴) <4300 SF. <p>3. Standard Pile Driving Conditions. Work involving piles shall adhere to one of the four methods below:</p> <ul style="list-style-type: none"> • Piles installed in-the-dry during low water or in-water between Nov. 8th - Apr. 9th, or • Must be drilled and pinned to ledge, or • Vibratory hammers used to install any size and quantity of wood, concrete or steel piles, or • Impact hammers limited to one hammer and <50 piles installed/day with the following: wood piles of any size, concrete piles ≤18-inches diameter, steel piles <12-inches diameter if the hammer is ≤3000 lbs and a wood cushion is used between the hammer and steel pile, and • For the methods above: <ul style="list-style-type: none"> ○ In-water noise levels shall not exceed >187dB cSEL re 1μPa or 206dB peak re 1μPa at a distance >10m from the pile being installed, and ○ In-water noise levels >150dB peak re 1μPa shall not exceed 12 consecutive hours on any given day and a 12 hour recovery period (i.e., in-water noise below 150dB peak re 1μPa) must be provided between work days. • Existing derelict, degraded or abandoned piles in the project area that are affected by project activities should be removed and properly disposed of in an upland location landward of MHW or OHW and not in wetlands, tidal wetlands, their substrate or mudflats.

<p>2. Moorings</p>	<p>1. Private, non-commercial, non-rental, single-boat moorings, provided:</p> <ul style="list-style-type: none"> • Authorized by the local harbormaster/town. • Not associated with any boating facility.¹¹ • Boat or mooring not located in a Federal Navigation Project or buffer zone¹² other than in a Federal Anchorage¹². Moorings in a Federal Anchorage not associated with a boating facility¹¹ and are not for rent. • No interference with navigation. • No new moorings located in SAS³. Prior to installation of moorings, a site-specific eelgrass survey should be conducted to document that eelgrass is not present. • When existing, authorized moorings in SAS³ are going to be replaced, they should be replaced with low impact mooring technology that prevents mooring chains from resting or dragging on the bottom substrate at all tides and helical anchors, or equivalent SAS protection systems where practicable. <p>2. Minor relocation of previously authorized moorings, provided:</p> <ul style="list-style-type: none"> • Authorized by the local harbormaster/town. • Not located in SAS³ • No interference with navigation. • Cannot be relocated into a Federal Navigation Project¹² other than a Federal Anchorage¹² <p>Note: <i>Cat 1 eligible moorings do not require SVNf.</i></p>	<p>1. Moorings associated with an existing boating facility¹¹. An eelgrass¹⁴ survey may be required.</p> <p>2. Moorings that don't meet the terms in Category 1 and don't require an Individual Permit. This includes private moorings with no harbormaster or means of local approval.</p> <p>3. Moorings located such that they, and/or vessels docked or moored at them, are within the buffer zone of the horizontal limits¹³ of a Federal Channel¹². (See Appendix H.) The buffer zone is equal to 3 times the authorized depth of that channel.</p> <p>4. An IP is required for moorings within the horizontal limits¹¹, or with moored vessels that extend, into the horizontal limits of a Federal Navigation Project¹², except those in Federal Anchorages¹².</p> <p><i>For 1-4 above, siting of new individual moorings in SAS³, including eelgrass¹⁴, should be avoided to the maximum extent practicable. If SAS³ cannot be avoided, plans should show elastic mooring systems that prevent mooring chains from resting or dragging on the bottom substrate at all tides and helical anchors, or equivalent SAS protection systems, where practicable. For moorings that appear to impact SAS, the Corps may require an eelgrass survey.</i></p>
<p>3. Structures, Floats and Lifts</p>	<p>1. Reconfiguration of existing authorized structures shall occur in-the-dry during low water.</p> <p>2. Minor relocation of previously authorized floats or moored floats/lobster cars, provided:</p> <ul style="list-style-type: none"> • Authorized by the local harbormaster/town. • Not located in SAS³. • No interference with navigation. • Cannot be relocated into a Federal Navigation Project¹² other than a Federal Anchorage¹². 	<p>1. New structures or floats, including floatways/skidways, built to access waterway (seasonal and permanent). Includes both pile supported and crib supported structures.</p> <p>2. Expansions to existing boating facilities¹¹</p> <ul style="list-style-type: none"> • <i>Pile-supported structures <400 SF, with attached floats totaling ≤200 SF.</i> • <i>Structures are ≤4' wide and have at least a 1:1 height:width ratio¹¹.</i> • <i>Floats supported a minimum of 18" above the substrate during all tides.</i> • <i>Structures & floats not located within 25' of any eelgrass⁸.</i> • <i>Moored vessels not positioned over SAS³.</i>

- *The Corps may require a letter of no objection from the abutter if structure is to be within 25 feet of the property line.*
 - *No structure extends across >25% of the waterway width at mean low water.*
 - *Not located within the buffer zone of the horizontal limits¹³ of a Corps Federal Navigation Project (FNP) (Appendix F). The buffer zone is equal to three times the authorized depth of that FNP.*
3. An Individual Permit is required for structures or floats, including floatways/skidways, located such that they and/or vessels docked or moored at them are within the horizontal limits¹³ of a Corps Federal Navigation Project¹² (see Appendix H).
 4. An Individual Permit is required for structures & floats associated with a new or previously unauthorized boating facility¹¹.
 5. Standard Pile Driving Conditions. Work involving piles shall adhere to one of the four methods below:
 - Piles installed in-the-dry during low water or in-water between Nov. 8th - Apr. 9th, or
 - Must be drilled and pinned to ledge, or
 - Vibratory hammers used to install any size and quantity of wood, concrete or steel piles, or
 - Impact hammers limited to one hammer and <50 piles installed/day with the following: wood piles of any size, concrete piles ≤18-inches diameter, steel piles <12-inches diameter if the hammer is ≤3000 lbs and a wood cushion is used between the hammer and steel pile, and
 - For the methods above:
 - In-water noise levels shall not exceed >187dB cSEL re 1μPa or 206dB peak re 1μPa at a distance >10m from the pile being installed, and
 - In-water noise levels >150dB peak re 1μPa shall not exceed 12 consecutive hours on any given day and a 12 hour recovery period (i.e., in-water noise below 150dB peak re 1μPa) must be provided between work days.
 - Existing derelict, degraded or abandoned piles in the project area that are affected by project activities should be removed and properly disposed of in an upland location landward of MHW or OHW and not in wetlands, tidal wetlands, their substrate or mudflats.

<p>4. Aids to Navigation and Temporary Recreational Structures</p>	<p>1. Temporary buoys, markers, floats, etc. for recreational use during specific events, provided they are removed within 30 days after use is discontinued.</p> <p>2. The placement of aids to navigation and regulatory markers which are approved by and installed in accordance with the requirements of the U.S. Coast Guard. (See 33 CFR 66, Chapter I, subchapter C).”</p> <p><i>Note: Cat 1 eligible aids to navigation and regulatory markers do not require SVNF.</i></p>	<p>Work not eligible for Category 1</p>
<p>5. Dredging, Disposal of Dredged Material, Beach Nourishment, and Rock Removal and Relocation</p>	<p>1. Maintenance dredging¹⁰ for navigational purposes <1,000 CY with upland disposal. Includes return water from upland contained disposal area, provided:</p> <ul style="list-style-type: none"> • Proper siltation controls are used. • Dredging & disposal operation limited to Nov. 8 – Apr. 9. • No impact to SAS³. • No dredging in intertidal areas. • No dredging within 100’ of shellfish beds. • No dredging in areas designated as Critical Habitat for Atlantic salmon [see GC 8(b) & (c)]. • For dredging in tidal waters outside of Atlantic salmon critical habitat, applicants must contact NMFS (see GC 8) to ensure no impacts to listed species such as shortnose sturgeon, Atlantic surgeon, and listed sturgeon critical habitat. • Project proponents must contact the USFWS for work on coastal beaches to ensure no impacts to piping plovers, roseate terns, rufa red knot, or their habitat [see GC 8(c)]. • No underwater blasting. <p>2. Maintenance dredging is not eligible for Category 1 if conducted in tidal portions of the Penobscot river upstream of a line extending from Turner Point in Castine to Moose Point (formerly Squaw Point) on Cape Jellison in Stockton Springs or in tidal portions of the Kennebec or Androscoggin Rivers upstream of a line extending from Doubling Point in Arrowsic to Hospital Point in West Bath.</p>	<p>1. Maintenance dredging¹⁰ ≥1,000 CY, new dredging <25,000 CY, or projects not meeting Category 1. Includes return water from upland contained disposal areas. Disposal includes:</p> <ul style="list-style-type: none"> • Upland. • Beach nourishment (above mean high water) of any area provided the dredging’s primary purpose is navigation or the sand is from an upland source. • Open water & confined aquatic disposal, if Corps finds the material suitable. <p>2. Beach nourishment associated with dredging when the primary purpose is not navigation requires at least a Category 2 review.</p> <p>3. Maintenance or new dredging¹⁰ and/or disposal in or affecting a SAS³ requires an Individual Permit.</p>

<p>6. Discharges of Dredged or Fill Material Incidental to the Construction of Bridges</p>	<p>1. Discharges of dredged or fill material incidental to the construction of bridges across navigable waters of the U.S., including cofferdams, abutments, foundation seals, piers, and temporary construction and access fills provided the U.S. Coast Guard authorizes such discharges as part of the bridge permit or appropriate approval. 2. Causeways and approach fills are not included in this category and require Category 2 or Individual Permit authorization.</p>	<p><1 acre temporary or permanent fill, excavation and/or secondary impacts (e.g., areas drained, flooded, fragmented or mechanically cleared). Fill area includes all temporary and permanent waterway fills, provided:</p> <ul style="list-style-type: none"> • Temporary or permanent fill in eelgrass¹⁴ <1000 SF. • Permanent fill in SAS (excluding eelgrass¹⁴) <4300 SF.
<p>7. Bank and Shoreline Stabilization</p>	<p>1. Bank stabilization projects <200 linear feet provided:</p> <ul style="list-style-type: none"> • ≤1 cubic yard of fill per linear foot placed along the bank waterward of high tide line. No fill or equipment will occur in SAS³. • Work conducted in the intertidal zone must be conducted in-the-dry during low water. • No structures angled steeper than 1H:1V and only rough-faced stone or fiber roll revetments allowed. • No driving of piles or sheeting. <p>2. Bank stabilization projects in excess of 200 linear feet (Applicant or Applicant + Abutters combined) must undergo Category 2 review.</p>	<p>1. Work not eligible for Category 1. 2. <1 acre temporary or permanent fill, excavation and/or secondary impacts (e.g., areas drained, flooded, fragmented or mechanically cleared). Fill area includes all temporary and permanent waterway fills, provided:</p> <ul style="list-style-type: none"> • Temporary or permanent fill in eelgrass¹⁴ <1000 SF. • Permanent fill in SAS (excluding eelgrass¹⁴) <4300 SF.
<p>8. Residential, Commercial, and Institutional Developments, and Recreational Facilities</p>	<p>Not Eligible</p>	<p>1. <1 acre temporary or permanent fill, excavation and/or secondary impacts (e.g., areas drained, flooded, fragmented or mechanically cleared). Fill area includes all temporary and permanent waterway fills, provided:</p> <ul style="list-style-type: none"> • Temporary or permanent fill in eelgrass¹⁴ <1000 SF. • Permanent fill in SAS (excluding eelgrass¹⁴) <4300 SF. <p>2. Conversions of previously authorized pile supported buildings over navigable waters to residences, offices, or other non-water dependent uses require at least a Category 2 review. 3. Floating house boats or businesses on floats require Category 2 review.</p>
<p>9. Utility Line Activities</p>	<p>1. Repair or maintenance of existing, currently serviceable, authorized utilities with no expansion or change in use:</p> <ul style="list-style-type: none"> • Conditions of the original authorization apply. • Trenching or filling is confined to the existing footprint. • In water work conducted between Nov 8 and Apr 9. • No new impact to SAS. <p>2. Particularly relevant is GC12. 3. <u>New work in, over, or under navigable waters</u> requires a PCN and Category 2 review. 4. Except for aerial utility lines, work is not eligible for Category 1 if conducted in tidal portions of the Penobscot River upstream of a line extending from Turner Point in Castine to Moose Point (formerly</p>	<p>1. New or replacement installations or work not otherwise eligible for Category 1. 2. <1 acre temporary or permanent fill, excavation and/or secondary impacts (e.g., areas drained, flooded, fragmented or mechanically cleared). Fill area includes all temporary and permanent waterway fills, provided:</p> <ul style="list-style-type: none"> • Temporary or permanent fill in eelgrass¹⁴ <1000 SF. • Permanent fill in SAS (excluding eelgrass¹⁴) <4300 SF. <p>3. Particularly relevant is GC12</p>

	Squaw Point) on Cape Jellison in Stockton Springs or in tidal	
10. Linear Transportation Projects (Not Including Stream Crossings)	Not eligible	<p><1 acre temporary or permanent fill, excavation and/or secondary impacts (e.g., areas drained, flooded, fragmented or mechanically cleared). Fill area includes all temporary and permanent waterway fills, provided:</p> <ul style="list-style-type: none"> • Temporary or permanent fill in eelgrass¹⁴ <1000 SF. • Permanent fill in SAS (excluding eelgrass¹⁴) <4300 SF.
11. Mining Activities	Not Eligible	Not Eligible
12. Boat Ramps and Marine Railways	<ol style="list-style-type: none"> 1. No new impact to SAS 2. Marine railway and boat ramp work not eligible for maintenance⁷ (i.e. not currently serviceable⁷) may be replaced “in-kind” with minor deviations⁷ provided: <ul style="list-style-type: none"> • Work is in the intertidal zone. • No fill expansion below high tide line. • Work conducted in-the-dry during low water. 3. No new boat ramps or marine railways. 	<ol style="list-style-type: none"> 1. Work not eligible for Category 1 2. <1 acre temporary or permanent fill, excavation and/or secondary impacts (e.g., areas drained, flooded, fragmented or mechanically cleared). Fill area includes all temporary and permanent waterway fills, provided: <ul style="list-style-type: none"> • Temporary or permanent fill in eelgrass¹⁴ <1000 SF. • Permanent fill in SAS (excluding eelgrass¹⁴) <4300 SF.
13. Land and Water-Based Renewable Energy Generation Facilities and Hydropower Projects	Not Eligible	<ol style="list-style-type: none"> 1. <1 acre temporary or permanent fill, excavation and/or secondary impacts (e.g., areas drained, flooded, fragmented or mechanically cleared). Fill area includes all temporary and permanent waterway fills, provided: <ul style="list-style-type: none"> • Temporary or permanent fill in eelgrass¹⁴ <1000 SF. • Permanent fill in SAS (excluding eelgrass¹⁴) <4300 SF. 2. No new impoundments.
14. Reshaping Existing Drainage Ditches and Mosquito Management	<ol style="list-style-type: none"> 1. ≤500 linear feet of drainage ditch will be modified. The reshaping of the ditch cannot increase drainage capacity beyond the original as-built capacity nor can it expand the area drained by the ditch as originally constructed (i.e., the capacity of the ditch must be the same as originally constructed and it cannot drain additional wetlands or other waters of the U.S.). 2. No new ditches or relocation of drainage ditches constructed in waters of the U.S.; the location of the centerline of the reshaped drainage ditch must be approximately the same as the location of the centerline of the original drainage ditch. 3. No effect on federally listed endangered or threatened species or critical habitat 	<ol style="list-style-type: none"> 1. Work not eligible for Category 1 2. <1 acre temporary or permanent fill, excavation and/or secondary impacts (e.g., areas drained, flooded, fragmented or mechanically cleared). Fill area includes all temporary and permanent waterway fills, provided: <ul style="list-style-type: none"> • Temporary or permanent fill in eelgrass¹⁴ <1000 SF. • Permanent fill in SAS (excluding eelgrass¹⁴) <4300 SF.

<p>15. Oil Spill and Hazardous Material Cleanup</p>	<p>Jurisdictional activities required for the containment and cleanup of oil and hazardous substances that are subject to the National Oil and Hazardous Substances Pollution Contingency Plan (40 CFR 300) provided that the work is done in accordance with the Spill Control and Countermeasure Plan required by 40 CFR 112.3 and any existing state contingency plan and provided that the Regional Response Team (if one exists in the area) concurs with the proposed containment and cleanup action. SAS³ must typically be restored in place at the same elevation.</p> <p><i>Note: SVN^F or a surrogate state reporting form may be submitted after the fact. No SVN^F is required for Category 1 eligible containment booms.</i></p>	<p>Work not eligible for Category 1</p>
<p>16. Cleanup of Hazardous and Toxic Waste</p>	<p>Not eligible - except for booms placed for hazardous and toxic waste containment and absorption and prevention which are eligible for SV.</p> <p><i>Note: No SVN^F is required for Category 1 eligible containment booms.</i></p>	<p>Specific jurisdictional activities with impacts of any area required to affect the containment, stabilization, or removal of hazardous or toxic waste materials that are performed, ordered, or sponsored by a government agency with established legal or regulatory authority. Wetlands and other SAS must typically be restored in place at the same elevation to qualify.</p>
<p>17. Scientific Measurement Devices</p>	<p>Scientific measurement devices whose purpose is to measure and record scientific data, such as staff gages, water recording devices, water quality testing and improvement devices, and similar structures. Structures may not restrict or concentrate movement of aquatic organisms; no activity results in a hazard to navigation; and no activity requiring underwater blasting.</p>	<p>1. Work not eligible for Category 1 2. <1 acre temporary or permanent fill, excavation and/or secondary impacts (e.g., areas drained, flooded, fragmented or mechanically cleared). Fill area includes all temporary and permanent waterway fills, provided:</p> <ul style="list-style-type: none"> • Temporary or permanent fill in eelgrass¹⁴ <1000 SF. • Permanent fill in SAS (excluding eelgrass¹⁴) <4300 SF.
<p>18. Survey Activities</p>	<p>Jurisdictional survey activities such as exploratory drilling, surveying and sampling activities, excluding any biological sampling devices. Does not include any activity requiring underwater blasting, seismic exploratory operations, or oil and gas exploration and fill for roads or construction pads. No activity may result in a hazard to navigation.</p>	<p>1. Work not eligible for Category 1 2. <1 acre temporary or permanent fill, excavation and/or secondary impacts (e.g., areas drained, flooded, fragmented or mechanically cleared). Fill area includes all temporary and permanent waterway fills, provided:</p> <ul style="list-style-type: none"> • Temporary or permanent fill in eelgrass¹⁴ <1000 SF. • Permanent fill in SAS (excluding eelgrass¹⁴) <4300 SF.
<p>19. Agricultural Activities</p>	<p>Not Eligible</p>	<p>Not Eligible</p>

<p>20. Fish & Wildlife Harvesting, Enhancement and Attraction Devices and Activities (Not Aquaculture)</p>	<p>Fish and wildlife harvesting, enhancement, and attraction devices and activities such as pound nets, crab traps, crab dredging, eel pots, lobster traps, and clam and oyster digging, and small fish attraction devices such as open water fish concentrators (sea kites, etc.). This does not authorize artificial reefs or impoundments and semi-impoundments of waters of the U.S. for the culture or holding of motile species such as lobster, or the use of covered oyster trays or clam racks. No activity that may result in a hazard to navigation. <i>Note: A SVNF is not required for these Category 1 eligible devices and activities.</i></p>	<p>1. Work not eligible for Category 1. 2. Impoundments or semi-impoundments of waters of the U.S. for the culture or holding of motile species such as lobster and new fish weirs with an impounded area \leq 1/2 acre. For Aquaculture operations, refer to Activity 24.</p>
<p>21. Habitat Restoration, Establishment and Enhancement Activities</p>	<p>1. Cultch placement in tidal waters is eligible for SV provided there are no salt marsh or vegetated shallow impacts. 2. SAS planting and transplanting \leq 100 SF in tidal waters; 3. No artificial or living reefs. 4. The activity is authorized in writing by a local, state, or non-Corps federal environmental agency. Water impoundments require PCN. 5. No conversion of i) a stream to wetland or vice versa, wetland to a pond or uplands, and ii) one wetland type to another. 6. No dam removal. 7. Shellfish habitat enhancement such as brushing the flats is eligible for Category 1, but not the use of netting which requires Category 2 review.</p>	<p>1. Work not eligible for Category 1. 2. Aquatic habitat restoration, establishment and enhancement provided those activities are proactive and result in net increases in aquatic resource functions and services.⁸</p>
<p>22. Previously Authorized Activities</p>	<p>Any work not commenced nor completed that was authorized in a written letter from the Corps under the GP in effect between October 12, 2010 and October 12, 2015. The terms and general conditions of this GP apply along with any special conditions in the written authorization.</p>	
<p>23. Stream & Wetland Crossings</p>	<p>Not Eligible</p>	<p>All temporary or permanent crossings of tidal navigable waters or adjacent tidal wetlands not eligible as maintenance require a PCN. GC 45 applies</p>
<p>24. Aquaculture</p>	<p>Not Eligible</p>	<p>Shellfish & finfish aquaculture (with the exception of Atlantic salmon and any other salmonid, or other federally listed endangered or threatened species), or other aquaculture facilities with no more than minimal individual and cumulative impacts to environmental resources or navigation. This is inclusive but not limited to cages, nets, bags, racks, long lines, fences, posts, poles, predator screening, etc. Aquaculture guidelines are provided at: www.maine.gov/dmr/aquaculture/index.htm.</p>

Endnotes/Definitions

¹ Bordering and Contiguous Wetlands: A bordering wetland is immediately next to its adjacent waterbody and may lie at, or below, the ordinary high water mark (mean high water in navigable waters) of that waterbody and is directly influenced by its hydrologic regime. Contiguous wetlands extend landward from their adjacent waterbody to a point where a natural or manmade discontinuity exists. Contiguous wetlands include bordering wetlands as well as wetlands that are situated immediately above the ordinary high water mark and above the normal hydrologic influence of their adjacent waterbody. Note, with respect to the federally designated navigable rivers, the wetlands bordering and contiguous to the tidally influenced portions of those rivers are reviewed under “II. Navigable Waters.”

² Direct, Secondary, and Cumulative Impacts/Effects:

Direct Impacts: The immediate loss of aquatic ecosystem within the footprint of the fill.

Secondary Impacts: These are effects on an aquatic ecosystem that are associated with a discharge of dredged or fill materials, but do not result from the actual placement of the dredged or fill material. Information about secondary effects on aquatic ecosystems shall be considered prior to the time final section 404 action is taken by permitting authorities. Some examples of secondary effects on an aquatic ecosystem are a) fluctuating water levels in all impoundment and downstream associated with the operation of a dam, b) septic tank leaching and surface runoff from residential or commercial developments on fill, and c) leachate and runoff from a sanitary landfill located in waters of the U.S. Put another way, secondary effects are those impacts outside the footprint of the fill that arise from and are associated with the discharge of dredged or fill material, including the operation of an activity or facility associated with the discharge. Examples may include habitat fragmentation; interruption of travel corridors for wildlife (for example, for amphibians that migrate to and from seasonal or vernal pools used as breeding habitat); hydrologic regime changes; and impacts from operation and maintenance activities for constructed facilities; such as noise/lighting, storm water runoff, and road kill of wetland dependent wildlife. Using the directions contained in the guidelines, we consider the circumstances of a proposed discharge and the project of which it is a part to evaluate the scope, extent, severity, and permanence of direct, secondary, and cumulative adverse effects upon the aquatic ecosystem.

Cumulative Impacts: The extent of past, present, and foreseeable developments in the area may be an important consideration in evaluating the significance of a particular project’s impacts. Although the impacts associated with a particular discharge may be minor, the cumulative effect of numerous similar discharges can result in a large impact. Cumulative impacts should be estimated only to the extent that they are reasonable and practical.

³ Special Aquatic Sites: Includes wetlands and saltmarsh, mudflats, riffles and pools, and vegetated shallows (predominantly comprised of eelgrass in Maine).

⁴ Construction Mats: Constructions, swamp and timber mats (herein referred to as “construction mats”) are generic terms used to describe structures that distribute equipment weight to prevent wetland damage while facilitating passage and providing work platforms for workers and equipment. They are comprised of sheets or mats made from a variety of materials in various sizes. A timber mat consists of large timbers bolted or cabled together. Corduroy roads, which are not considered to be construction mats, are cut trees and/or saplings with the crowns and branches removed, and the trunks lined up next to one another. Corduroy roads are typically installed as permanent structures. Like construction mats, they are considered as fill whether they’re installed temporarily or permanently.

⁵ Vernal Pools: A vernal pool, also referred to as a seasonal forest pool, is a temporary to semi-permanent body of water occurring in a shallow depression that typically fills during the spring or fall and may dry during the summer. Vernal pools have no permanent inlet or outlet and no viable populations of predatory fish. A vernal pool may provide the primary breeding habitat for wood frogs (*Rana sylvatica*), spotted salamanders (*Ambystoma maculatum*), blue-spotted salamanders (*Ambystoma laterale*), and fairy shrimp (*Eubranchipus* sp.), as well as valuable habitat for other plants and wildlife, including several rare, threatened, and endangered species. A vernal pool intentionally created for the purposes of compensatory mitigation is included in this definition. For the purposes of this GP, the presence of any of the following species in any life stage in any abundance level/quantity would designate the waterbody as a vernal pool: fairy shrimp, blue spotted salamanders, spotted salamanders or wood frogs. The Corps may determine during a Category 2 review that a waterbody should not be regulated as a VP based on available evidence. For the purposes of this GP, the VP Management Areas are the: Vernal Pool Depression (includes the vernal pool depression up to the spring or fall high water mark, and includes any vegetation growing within the depression), Vernal Pool Envelope (area within 100 FT of the VP Depression’s edge) and Critical Terrestrial Habitat (area within 100-750 FT of the Vernal Pool Depression’s edge). [*Note: Critical Terrestrial Habitat is defined as 100 -750 FT on page 243 of the document “Science and Conservation of Vernal Pools in Northeastern North America.” Calhoun and deMaynadier, 2008, which is referenced in Appendix G, page 3, Paragraph 10(b).

⁶ **Water Diversions:** Water diversions are activities such as bypass pumping or water withdrawals. Temporary flume pipes, culverts or cofferdams where normal flows are maintained within the stream boundary's confines aren't water diversions. "Normal flows" are defined as no change in flow from pre-project conditions.

⁷ **Maintenance: a)** The repair, rehabilitation, or replacement of any previously authorized, currently serviceable structure or fill, or of any currently serviceable structure or fill authorized by 33 CFR 330.3 – "Activities occurring before certain dates," provided that the structure or fill is not to be put to uses differing from those uses specified or contemplated for it in the original permit or the most recently authorized modification.

- Minor deviations in the structure's configuration or filled area, including those due to changes in materials, construction techniques, or current construction codes or safety standards that are necessary to make repair, rehabilitation, or replacement are authorized.
- Currently serviceable means useable as is or with some maintenance, but not so degraded as to essentially require reconstruction.
- No seaward expansion for bulkheads or any other fill activity is considered Category 1 maintenance.
- Only structures or fills that were previously authorized and are in compliance with the terms and condition of the original authorization can be maintained as a non-regulated activity under 33 CFR 323.4(a)(2), or in accordance with the Category 1 or 2 thresholds in Appendix A.

b) The state's maintenance provisions may differ from the Corps and may require reporting and written authorization from the state.

c) Contact the Corps to determine whether stream crossing replacements require a written application to the Corps for at least a Category 2 review.

d) Exempted Maintenance. In accordance with 33 CFR 323.4(a)(2), any discharge of dredged or fill material that may result from any of the following activities is not prohibited by or otherwise subject to regulation under Section 404 of the CWA: "Maintenance, including emergency reconstruction of recently damaged parts, of currently serviceable structures such as dikes, dams, levees, groins, riprap, breakwaters, causeways, bridge abutments or approaches, and transportation structures. Maintenance does not include any modification that changes the character, scope, or size of the original fill design."

⁸ **Aquatic Habitat Restoration, Establishment and Enhancement:** The Corps will decide if a project qualifies and must determine in consultation with federal and state agencies that the net effects are beneficial. The Corps may refer to Nationwide Permit 27 published in the 3/12/07 Federal Register. Activities authorized here may include, but are not limited to: the removal of accumulated sediments; the installation, removal, and maintenance of small water control structures, dikes, and berms; the installation of current deflectors; the enhancement, restoration, or establishment of riffle and pool stream structure; the placement of in-stream habitat structures; modifications of the stream bed and/or banks to restore or establish stream meanders; the backfilling of artificial channels and drainage ditches; the removal of existing drainage structures; the construction of small nesting islands in inland waters; the construction of open water areas; the construction of native shellfish species habitat over unvegetated bottom for the purpose of habitat protection or restoration in tidal waters; shellfish seeding; activities needed to reestablish vegetation, including plowing or discing for seed bed preparation and the planting of appropriate wetland species; mechanized land clearing to remove non-native invasive, exotic, or nuisance vegetation; and other related activities. Only native plant species should be planted at the site.

⁹ **Brushing the Flats:** The placement of tree boughs, wooden lath structure, or small-mesh fencing on mudflats to enhance recruitment of soft-shell clams (*Mya arenaria*).

¹⁰ **Maintenance Dredging:** This includes only those areas and depths previously authorized by the Corps and dredged. The Corps may require proof of authorization. Maintenance dredging typically refers to the routine removal of sediment to maintain the design depths of serviceable navigation channels, harbors, basins, marinas, boat launches, and port facilities. Maintenance dredging is conducted for navigational purposes and does not include any expansion of the previously dredged area or depth. The Corps may review a maintenance dredging activity as new dredging if sufficient time has elapsed to allow for the colonization of SAS, shellfish, etc.

¹¹ **Boating Facilities:** Facilities that provide for a fee, rent, or sell mooring space, such as marinas, yacht clubs, boat clubs, boat yards, town facilities, dockominiums, etc.

¹² **Federal Navigation Projects (FNPs):** FNPs are comprised of Federal Channels and Federal Anchorages. See Appendix F for their location and contact the Corps for more information. "Horizontal Limits" is the outer edge of an FNP. "Buffer Zone" is equal to three times the authorized depth of that channel.

¹³ **Horizontal Limits:** The outer edge of a Federal Navigation Project (FNP). See Appendix F and contact the Corps for information on FNP's.

¹⁴ **Eelgrass (*Zostera marina*):** A type of rooted aquatic vegetation that exists in intertidal and shallow subtidal areas known as vegetated shallows. See www.nero.noaa.gov/hcd/ for eelgrass survey guidance. Note: Eelgrass surveys should be conducted between May and October unless otherwise directed.

¹⁵ **Structures:** The height of structures shall at all points be equal to or exceed the width of the deck. For the purpose of this definition, height shall be measured from the marsh substrate to the bottom of the longitudinal support beam.

¹⁶ **Agricultural Activities:** The Clean Water Act exempts certain discharges associated with normal farming, ranching, and forestry activities such as plowing, cultivating, minor drainage, and harvesting for the production of food, fiber, and forest products, or upland soil and water conservation practices (Section 404(f)(1)(A)). Applicants are strongly advised to contact the Corps for a determination of whether their activity is exempt or requires a permit.



Appendix B: Self-Verification Notification Form
(for all tidal and non-tidal projects in Maine subject to Corps jurisdiction)

**US Army Corps
of Engineers**®
New England District

At least two weeks before work commences, complete **all** fields (write “none” if applicable) below or use the fillable form at www.nae.usace.army.mil/missions/regulatory.aspx. Send this form, a location map, any project plans, and an Official Species List (See GC 8) to the address noted below; fax to (207) 623-8206; or email to jay.l.clement@usace.army.mil. The two-week lead time is not required for emergency situations (see page 4 for definition). Please call (207) 623-8367 with questions.

Maine Project Office
U.S. Army Corps of Engineers
New England District
675 Western Avenue #3
Manchester, Maine 04351

State Permit Number: _____
Date of State Permit: _____
State Project Manager: _____

Permittee: _____
Address, City, State & Zip: _____
Phone(s) and Email: _____

Contractor: _____
Address, City, State & Zip: _____
Phone(s) and Email: _____

Consultant/Engineer/Designer: _____
Address, City, State & Zip: _____
Phone(s) and Email: _____

Wetland/Vernal Pool Consultant: _____
Address, City, State & Zip: _____
Phone(s) and Email: _____

Project Location/Description: _____
Address, City, State & Zip: _____
Latitude/Longitude Coordinates: _____ Tax Map/Lot: _____
Waterway Name: _____
Work Description: _____

Provide any prior Corps permit numbers: _____
Proposed Work Dates: Start: _____ Finish: _____

Area of wetland impact: _____ SF (leave blank if work involves structures & no fill in Navigable Waters)
Area of waterway impact: _____ SF (leave blank if work involves structures & no fill in Navigable Waters)
Area of compensatory mitigation provided: _____ SF

Work will be done under the following Appendix A categories (circle all that apply):
I. Inland Waters and wetlands: 1 2 3 4 5 6 7 8 9 10 11 12 13 14 15 16 17 18 19 20 21 22 23 24
II. Navigable Waters: 1 2 3 4 5 6 7 8 9 10 11 12 13 14 15 16 17 18 19 20 21 22 23 24

Your name/signature below, as permittee, indicates that you accept and agree to comply with the terms, eligibility criteria, and general conditions of Category 1 of the Maine General Permit.

Permittee Printed Name: _____
Permittee Signature: _____ Date: _____



Appendix C: Content of Pre-Construction Notification

In addition to the following required information, the applicant must provide additional information as the Corps deems essential to make a public interest determination including, where applicable, a determination of compliance with the Section 404(b)(1) guidelines or ocean dumping criteria. Such additional information may include environmental data and information on alternate methods and sites as may be necessary for the preparation of the required environmental documentation. For a more comprehensive checklist, go to www.nae.usace.army.mil/missions/regulatory >> Forms >> Application and Plan Guideline Checklist. Please check with the Corps for project-specific requirements.

Information required for all projects:

- Corps application form ([ENG Form 4345](#)) or appropriate state application form (see Appendix E). Forms may need to be supplemented to include the information noted below.
- Proof of notification to the SHPO and the appropriate THPOs (see Appendix E).
- Official Species List for any federally listed endangered or threatened species (Instructions at Appendix D)
- Drawings, sketches, or plans (detailed engineering plans and specifications are not required) that are legible, reproducible (color is encouraged, but features must be distinguishable in black and white), no larger than 11"x17", with bar scale. Wetland area impact sheets should have the highest resolution possible to show work within Corps jurisdiction (do not just reduce project overview or cut large-scale plan into quadrant sheets). Provide locus map and a plan overview of the entire property with a key index to the individual impact sheets. A locus map be on a section of color USGS topographic map is encouraged. Digital submissions are encouraged.
- Include:
 - All direct, secondary, permanent and temporary effects the project would cause, including the anticipated amount of impacts to waters of the U.S. expected to result from the activity, in acres, linear feet, or other appropriate unit of measure.
 - Any historic permanent fill associated with each single and complete project.
 - Cross-section views of all wetland and waterway fill areas and wetland replication areas.
 - Delineation of all wetlands, other special aquatic sites (vegetated shallows, saltmarsh, mudflats, riffles and pools, coral reefs, and sanctuaries and refuges), and other waters, such as lakes and ponds, and perennial, intermittent, and ephemeral streams, on the project site. Use Federal delineation methods and include Corps wetland delineation data sheets (see GC 2).
 - MLW and MHW elevations in tidal waters. Show the HTL elevations when fill is involved. Show OHW elevation in lakes and non-tidal streams.
 - Existing and proposed conditions.
 - For vegetated shallow and eelgrass survey guidance, see www.nae.usace.army.mil/missions/regulatory >> Jurisdictional Limits and Wetlands >> Submerged Aquatic Vegetation Survey Guidance for the New England Region.
 - Show all known VPs on the project site. See GC 23 for vernal pool identification requirements.
- Volume, type, and source of fill material to be discharged into waters and wetlands, including the area(s) (in square feet or acres) of fill in wetlands, below OHW in inland waters and below the HTL in coastal waters.

- An Official Species List of federally “listed species or critical habitat” present in the action area (see GC 8).
- A restoration plan showing how all temporary fills and structures will be removed and the area restored to pre-project conditions (see GC 43).

Information that may be required:

- Photographs of wetland/waterway to be impacted. Photos at low tide are preferred for work in tidal waters.
- For drawings, sketches, or plans:
 - The vertical datum for all coastal projects must be in U.S. survey feet and referenced to MLLW and current tidal epochs, with a reference chart showing conversion factor to NAVD88; do not use local datum. See www.nae.usace.army.mil/missions/regulatory >> Forms and Publications >>Vertical Datum - FEMA (Jul 2007);
 - The horizontal state plane coordinates shall be in U.S. survey feet and based on the appropriate state plane coordinate system.
- For the construction of a filled area or pile or float-supported platform, the use of, and specific structures to be erected on, the fill or platform.
- For the discharge of dredged or fill material into waters of the U.S. or the transportation of dredged material for the purpose of disposing of it in ocean waters, the source of the material; the purpose of the discharge, a description of the type, composition and quantity of the material; the method of transportation and disposal of the material; and the location of the disposal site.
- For the discharge of dredged or fill material into waters of the U.S., include a statement describing how impacts to waters of the U.S. are to be avoided and minimized. Include either a statement describing how impacts to waters of the U.S. are to be compensated for or a statement explaining why compensatory mitigation should not be required for the proposed impacts.
- Purpose and need for the proposed activity;
- Limits and coordinates of any Federal Navigation Project in the vicinity of the project area.
- Limits and coordinates of any proposed mooring field, reconfiguration zone or aquaculture activity. Provide coordinates for all corners;
- Schedule of construction/activity;
- Names and addresses of adjoining property owners;
- Location and dimensions of adjacent structures;
- List of authorizations required by other Federal, interstate, state, or local agencies for the work, including all approvals received or denials already made.
- Identification and description of potential impacts to Essential Fish Habitat (defined at VI. Definitions and Acronyms).
- Identification of potential discharges of pollutants to waters, including potential impacts to impaired waters, in the project area (see GC 19).
- Invasive Species Control Plan (see GC 24). For sample control plans, see www.nae.usace.army.mil/missions/regulatory >> Invasive Species.
- Wildlife Action Plan (WAP) maps. Contact Maine Inland Fisheries & Wildlife (Appendix E) or on line at http://www.maine.gov/ifw/wildlife/conservation/action_plan.html

Information for dredging projects that may be required:

- Sediment testing, including physical (e.g., grain-size analysis), chemical and biological testing. For projects proposing open water disposal, applicants are encouraged to contact the Corps as early as possible regarding sampling and testing protocols. Sampling and testing of sediments without such contact should not occur and if done, would be at the applicant’s risk.
- The area in square feet and volume of material to be dredged below mean high water.

- Existing and proposed water depths.
- Type of dredging equipment to be used.
- Nature of material (e.g., silty sand).
- Any existing sediment grain size and bulk sediment chemistry data for the proposed or any nearby projects.
- Information on the location and nature of municipal or industrial discharges and occurrence of any contaminant spills in or near the project area.
- Shellfish survey.
- Location of the disposal site (include locus sheet).
- Identification and description of any potential impacts to Essential Fish Habitat.
- Delineation of submerged aquatic vegetation (e.g., eelgrass beds).

Information for aquaculture projects that may be required:

- Maine Aquaculture guidelines and joint Corps/Maine DMR applications may be found at: www.maine.gov/dmr/aquaculture/index.htm.
- In addition to the information required above, applications must also include:
 - Whether canopy predator nets are being used.

Appendix D: Instruction for USFWS IPaC Project Builder/Official Species List

NOTE: These instructions are subject to change by the USFWS. Users should check this GP's Corps webpage for the latest instructions or click [here](#).

In your internet browser go to <http://ecos.fws.gov/ipac/>

1. Click on get started.
2. Click on enter project location.
3. Search or zoom to your project location. (You can enter an address and then zoom in with your mouse).
4. Define your area. (Select the polygon tool and click around the boundary of your project.) or (Use the draw a line tool for linear projects)

Note: You can change/select the map from Streets to Satellite or Topo in the lower left corner of the map.

5. Click finished drawing then click confirm and select continue.

6. On the next page under Tasks (lower left), select Request an official species list. The pane will open. Select "request official species list" again.

7. A new page will open. Fill in the project information blanks with the project name, brief description, project type, lead agency, and contact information. Be sure to check the box to verify this is a legitimate project. Click on Submit Official Species List Request.

8. You will be sent an e-mail with instructions to complete the request by clicking on the link provided.

9. The site will open Official Species List Request Completed. Under the Maine Ecological Services Field Office address you will see "Official Species List Document". Click on that link and your document will open. Save and or print a copy and **include the entire report with your application.**

Note, you will receive a second e-mail with the same information. You can save the link in the event you need to return to the IPaC site for an updated list.

If a period of time has passed since your initial "Official Species List" identifier number was generated, you may choose to generate an "UPDATED SPECIES LIST". To do this, return to the IPaC homepage at <http://ecos.fws.gov/ipac> site. In the middle of the page, click the purple "Need an updated species list" link.

On the request an "Updated Official Species List" page, complete the information in the boxes provided. You will need the project specific official consultation code generated and stated on the original official list as well as the email address entered with the original submission.

Click "Request Updated Species List". Print, or save.

Appendix E: Contacts and Tribal Areas of Interest

1. Federal

U.S. Army Corps of Engineers
Maine Project Office
675 Western Avenue #3
Manchester, ME 04351
(207) 623-8367 (phone); (207) 623-8206 (fax)

Federal Emergency Management Agency
99 High St.
Boston, MA 02110
(877) 336-2734 (phone)
(Flood Plain Management)

U.S. Environmental Protection Agency
5 Post Office Square
Suite 100 (OEP05-2)
Boston, MA 02109-3912
(617) 918-1589 (phone)

National Marine Fisheries Service
55 Great Republic Drive
Gloucester, MA 01930
(978) 281-9102 (phone); (978) 281-9301 (fax)
(Federal endangered species & EFH)

U.S. Fish and Wildlife Service
Maine Field Office
17 Godfrey Drive, Suite 2
Orono, ME 04473
(207) 866-3344 (phone); (207) 866-3351 (fax)
(Federal endangered species)

National Park Service
North Atlantic Region
15 State Street
Boston, MA 02109
(617) 223-5203 (phone)
(Wild and Scenic Rivers)

National Marine Fisheries Service
Maine Field Office
17 Godfrey Drive Suite 1
Orono, ME 04473
(207) 866-7379 (phone); (207) 866-7342 (fax)
(Federal endangered species)

Commander (dpb)
First Coast Guard District
One South Street - Battery Bldg
New York, NY 10004-1466
(212) 668-7021 (phone); (212) 668-7967 (fax)
(bridge permits)

2. State of Maine

a. Department of Environmental Protection *(State permits & Water Quality Certifications)*

Division of Land Resource Regulation
Bureau of Land and Water Quality
17 State House Station
Augusta, Maine 04333
(207) 287-7688 (phone)

Eastern Maine Regional Office
106 Hogan Road
Bangor, Maine 04401
(207) 941-4570 (phone)

Southern Maine Regional Office
312 Canco Road
Portland, Maine 04103
(201) 822-6300 (phone)

Northern Maine Regional Office
1235 Central Drive - Skyway Park
Presque Isle, Maine 04769
(207) 764-0477 (phone)

b. Department of Agriculture, Conservation and Forestry

i. Maine Land Use Planning Commission (LUPC) (*State permits & Water Quality Certifications in the unorganized areas of the State*)

Augusta Office
22 State House Station
Augusta, Maine 04333-0022
(207) 287-2631 (phone); (207) 287-7439 (fax)

Downeast Regional Office
106 Hogan Rd, Suite 8
Dorothea Dix Complex
Bangor, Maine 04401
(207) 941-4052 (phone); (207) 941-4222 (fax)

Greenville Regional Office
43 Lakeview Drive
P.O. Box 1107
Greenville, Maine 04441
(207) 695-2466 (phone); (207) 695-2380 (fax)

Ashland Regional Office
45 Radar Road
Ashland, ME 04732-3600
(207) 435-7963 (phone); (207) 435-7184 (fax)

Rangley Regional Office
133 Fyfe Road
PO Box 307
West Farmington, ME 04992
(207) 670-7493 (phone); (207) 287-7439 (fax)

East Millinocket Regional Office
191 Main Street
East Millinocket, ME 04430
(207) 746-2244 (phone); (207) 746-2243 (fax)

ii. Maine Coastal Program

Department of Agriculture, Conservation and Forestry
Bureau of Resource Information and Land Use Planning
17 Elkins Lane {physical address}
State House Station 93
Augusta, Maine 04333-0038
(207) 287-2801 (phone); (207) 287-2353 (fax)
(*CZM consistency determinations*)

iii. Division of Parks and Public Lands

22 State House Station
Augusta, Maine 04333
(207) 287-3061 (phone); (207) 287-6170 (fax)
(*submerged lands leases*)

c. Department of Marine Resources

P.O. Box 8
West Boothbay Harbor, Maine 04575
(207) 633-9500 (phone); (207) 624-6024 (fax)
(*aquaculture leases*)

3. Historic Properties

a. State Historic Preservation Officer (SHPO)

Mr. Kirk F. Mohney, Director

Maine Historic Preservation Commission (MHPC)
65 State House Station
Augusta, Maine 04333-0065
(207) 287-2132 (phone); (207) 287-2335 (fax)
Area of concern: The entire State of Maine

b. Tribal Historic Preservation Officers (THPOs)

Note: The area of concern for each tribe is the entire State of Maine

THPO & Environmental Planner
Houlton Band of Maliseet Indians
88 Bell Road
Littleton, Maine 04730
(207) 532-4273, x215 (phone)
(207) 532-6883 (fax)
envplanner@maliseets.com
ogs1@maliseets.com

THPO
Aroostook Band of Micmacs
7 Northern Road
Presque Isle, Maine 04769
(207) 764-1972 (phone); (207) 764-7667 (fax)
jpictou@mimca-nsn.gov

THPO
Passamaquoddy Tribe of Indians
Pleasant Point Reservation
P.O. Box 343
Perry, Maine 04667
(207) 853-2600 (phone); (207) 853-6039 (fax)
soctomah@gmail.com

THPO
Penobscot Nation
Cultural and Historic Preservation Dept.
12 Wabanaki Way
Indian Island, Maine 04468
(207) 817-7471 (phone)
chris.sockalexis@penobscotnation.org

THPO
Passamaquoddy Tribe of Indians
Indian Township Reservation
P.O. Box 301
Princeton, Maine 04668
(207) 796-2301 (phone)
(207) 796-5256 (fax); soctomah@gmail.com

4. Organizational Websites (Note – Subject to Change):

U.S. Army Corps of Engineers, N.E. District	www.nae.usace.army.mil/missions/regulatory.aspx
U.S. Army Corps of Engineers, Headquarters	See above link>>Useful Links>>Federal Agency Links
U.S. Environmental Protection Agency	www.epa.gov/owow/wetlands
National Marine Fisheries Service	www.nmfs.noaa.gov
U.S. Fish and Wildlife Service	www.fws.gov/mainefieldoffice
National Park Service	www.nps.gov/rivers/index.html
Maine Department of Environmental Protection	www.maine.gov/dep
Maine Department of Agriculture, Conservation and Forestry	www.maine.gov/acf/index.shtml
Maine Land Use Planning Commission	www.maine.gov/doc/lupc/commission/offices.shtml
Maine Department of Marine Resources	www.maine.gov/dmr/index.htm
State of Maine - Aquaculture Guidelines	www.maine.gov/dmr/aquaculture/index.htm

Appendix F: Definitions

Definitions

Attendant Features: Occurring with or as a result of; accompanying.

Biodegradable: A material that decomposes into elements found in nature within a reasonably short period of time and will not leave a residue of plastic or a petroleum derivative in the environment after degradation. Examples of biodegradable materials include jute, sisal, cotton, straw, burlap, coconut husk fiber (coir) or excelsior. In contrast, degradable plastics break down into plastic fragments that remain in the environment after degradation.

Boating facilities: These provide, rent or sell mooring space, such as marinas, yacht clubs, boat yards, dockminiums, town facilities, land/home owners, etc. Not classified as boating facilities are piers shared between two abutting properties or town mooring fields that charge an equitable user fee based on the actual costs incurred.

Brushing the Flats: The placement of tree boughs, wooden lath structure, or small-mesh fencing on mudflats, or any bottom disturbance (e.g., discing, plowing, raking, etc.), to enhance recruitment of shellfish.

Buffer Zone: The buffer zone of an FNP is equal to three times the authorized depth of the FNP.

Construction mats: Constructions, swamp and timber mats (herein referred to as “construction mats”) are generic terms used to describe structures that distribute equipment weight to prevent wetland damage while facilitating passage and providing work platforms for workers and equipment. They are comprised of sheets or mats made from a variety of materials in various sizes. A timber mat consists of large timbers bolted or cabled together. Corduroy roads, which are not considered to be construction mats, are cut trees and/or saplings with the crowns and branches removed, and the trunks lined up next to one another. Corduroy roads are typically installed as permanent structures. Like construction mats, they are considered as fill whether they are installed temporarily or permanently.

Cumulative effects: See “Direct, secondary, and cumulative effects.”

Direct, secondary, and cumulative effects:

Direct Effects: The loss of aquatic ecosystem within the footprint of the discharge of dredged or fill material. Direct effects are caused by the action and occur at the same time and place.

Secondary Effects: These are effects on an aquatic ecosystem that are associated with a discharge of dredged or fill materials, but do not result from the actual placement of the dredged or fill material. Information about secondary effects on aquatic ecosystems shall be considered prior to the time final Section 404 action is taken by permitting authorities. Some examples of secondary effects on an aquatic ecosystem are a) aquatic areas drained, flooded, fragmented, or mechanically cleared, b) fluctuating water levels in all impoundment and downstream associated with the operation of a dam, c) septic tank leaching and surface runoff from residential or commercial developments on fill, and d) leachate and runoff from a sanitary landfill located in waters of the U.S. See 40 CFR 230.11(h).

Cumulative Effects: The changes in an aquatic ecosystem that are attributable to the collective effect of a number of individual 1) discharges of dredged or fill material, or 2) structures. Although the impact of a particular discharge may constitute a minor change in itself, the cumulative effect of numerous such piecemeal changes can result in a major impairment of the water resources and interfere with the productivity and water quality of existing aquatic ecosystems. See 40 CFR 230(g).

Dredging:

Maintenance Dredging: Includes areas and depths previously authorized by the Corps and dredged. The Corps may require proof of authorization. Maintenance dredging typically refers to the routine removal of accumulated sediment from channel beds to maintain the design depths of navigation channels, harbors, marinas, boat launches and port facilities. Routine maintenance dredging is conducted regularly for navigational purposes (typically at least once every ten years) and does not include any expansion of the previously dredged area or depth. The Corps may review a maintenance dredging activity as new dredging if sufficient time has elapsed to allow for the colonization of SAS,

shellfish, etc. The main characteristics of maintenance dredging projects are variable quantities of material; soft, uncompacted soil; contaminant content possible; thin layers of material; occurring in navigation channels and harbors; repetitive activity

New Dredging: Dredging of an area or to a depth that has never been authorized by the Corps or dredged.

Dredged material & discharge of dredged material: These are defined at 323.2(c) and (d). The term dredged material means material that is excavated or dredged from waters of the U.S.

Essential Fish Habitat (EFH): This is broadly defined to include those waters and substrate necessary to fish for spawning, breeding, feeding, or growth to maturity.

Fill material & discharge of fill material: These are defined at 323.2(e) and (f). The term fill material is defined as material placed in waters of the U.S. where the material has the effect of either replacing any portion of a water of the U.S. with dry land or changing the bottom elevation of any portion of a water of the U.S.

Federal anchorages, Federal channels and Federal turning basin: Refer to Appendix H for those in Maine

Federal navigation projects (FNPs): These areas are maintained by the Corps; authorized, constructed and maintained on the premise that they will be accessible and available to all on equal terms; and are comprised of Federal Anchorages, Federal Channels and Federal Turning Basins. The buffer zone is equal to three times the authorized depth of a FNP. More information on the following FNPs is provided at www.nae.usace.army.mil/missions/navigation.aspx >> Navigation Projects.

Flume: An open artificial water channel, in the form of a gravity chute, that leads water from a diversion dam or weir completely aside a natural flow. A flume can be used to measure the rate of flow.

Frac out: During normal drilling operations, drilling fluid travels up the borehole into a pit. When the borehole becomes obstructed or the pressure becomes too great inside the borehole, the ground fractures and fluid escapes to the surface.

Independent utility: A test to determine what constitutes a single and complete non-linear project in the Corps regulatory program. A project is considered to have independent utility if it would be constructed absent the construction of other projects in the project area. Portions of a multi-phase project that depend upon other phases of the project do not have independent utility. Phases of a project that would be constructed even if the other phases were not built can be considered as separate single and complete projects with independent utility.

Individual Permit: A Department of the Army authorization that is issued following a case-by-case evaluation of a specific structure or work in accordance with the procedures of 33 CFR 322, or a specific project involving the proposed discharge(s) in accordance with the procedures of 33 CFR 323, and in accordance with the procedures of 33 CFR 325 and a determination that the proposed discharge is in the public interest pursuant to 33 CFR 320.

Maintenance: Regulations on maintenance are provided at 33 CFR 323.4. The following definitions are applicable:

Minor deviations: Deviations in the structure's configuration or filled area, including those due to changes in materials, construction techniques, or current construction codes or safety standards, which are necessary to make repair, rehabilitation, or replacement are permitted, provided the adverse environmental effects resulting from such repair, rehabilitation, or replacement are minimal.

Currently serviceable: Useable as is or with some maintenance, but not so degraded as to essentially require reconstruction.

Marina reconfiguration zone: A Corps-authorized area in which permittees may rearrange pile-supported structures and floats without additional authorizations. A reconfiguration zone does not grant exclusive privileges to an area or an increase in structure or float area.

Navigable waters of the U.S.: See Waters of the U.S. below.

Overall project: See "single and complete linear project" below.

Practicable: Available and capable of being done after taking into consideration cost, existing technology, and logistics in light of overall project purposes.

Permanent impacts: Permanent impacts means waters of the U.S. that are permanently affected by filling, flooding, excavation, or drainage because of the regulated activity. Permanent impacts include permanent discharges of dredged or fill material that change an aquatic area to dry land, increase the bottom elevation of a waterbody, or change the use of a waterbody. Temporary impacts include waters of the U.S. that are temporarily filled, flooded, excavated, drained or mechanically cleared because of the regulated activity.

Pre-construction notification (PCN): A request submitted by the project proponent to the Corps for confirmation that a particular activity is authorized by this GP. The request may be a permit application, letter, or similar document that includes information about the proposed work and its anticipated environmental effects. Pre-construction notification may be required by the terms and conditions of these GPs. A PCN may be voluntarily submitted in cases where PCN is not required and the project proponent wants confirmation that the activity is authorized under this GP.

Secondary effects: See “Direct, secondary, and cumulative effects.”

Single and complete linear project: A linear project is a project constructed for the purpose of getting people, goods, or services from a point of origin to a terminal point, which often involves multiple crossings of one or more waterbodies at separate and distant locations. The term “single and complete project” is defined as that portion of the total linear project proposed or accomplished by one owner/developer or partnership or other association of owners/developers that includes all crossings of a single water of the U.S. (i.e., a single waterbody) at a specific location. For linear projects crossing a single or multiple waterbodies several times at separate and distant locations, each crossing is considered a single and complete project for the purposes of this GP. However, individual channels in a braided stream or river, or individual arms of a large, irregularly shaped wetland or lake, etc., are not separate waterbodies, and crossings of such features cannot be considered separately.

The overall project, for purposes of this GP, includes all regulated activities that are reasonably related and necessary to accomplish the project purpose.

Single and complete non-linear project: For non-linear projects, the term “single and complete project” is defined at 33 CFR 330.2(i) as the total project proposed or accomplished by one owner/developer or partnership or other association of owners/developers. For non-linear projects, the single and complete project must have independent utility (see definition).

Special aquatic sites: These include inland and saltmarsh wetlands, mud flats, vegetated shallows, sanctuaries and refuges, coral reefs, and riffle and pool complexes. These are defined at 40 CFR 230 Subpart E.

Stream channelization: The manipulation of a stream’s course, condition, capacity, or location that causes more than minimal interruption of normal stream processes. A channelized stream remains a water of the United States.

Temporary impacts: See permanent impacts above.

Utility line: Any pipe or pipeline for the transportation of any gaseous, liquid, liquescent, or slurry substance, for any purpose, and any cable, line, or wire for the transmission for any purpose of electrical energy, telephone, and telegraph messages, and radio and television communication. The term ‘utility line’ does not include activities that drain a water of the U.S., such as drainage tile or French drains, but it does apply to pipes conveying drainage from another area.

Vegetated shallows: Permanently inundated areas that under normal circumstances support communities of rooted aquatic vegetation, such as eelgrass and widgeon grass (*Ruppiamaritima*) in marine systems (doesn’t include salt marsh) as well as a number of freshwater species in rivers and lakes. Note: These areas are also commonly referred to as submerged aquatic vegetation (SAV).

Vernal pools (VPs): For the purposes of this GP, VPs are depressional wetland basins that typically go dry in most years and may contain inlets or outlets, typically of intermittent flow. Vernal pools range in both size and depth depending upon landscape position and parent material(s). Pools usually

support one or more of the following obligate indicator species: wood frog, spotted salamander, blue-spotted salamander, marbled salamander, Jefferson's salamander and fairy shrimp. However, they should preclude sustainable populations of predatory fish.

VP areas are:

- Depression (includes the VP depression up to the spring or fall high water mark, and includes any vegetation growing within the depression),
- Envelope (area within 100 feet of the VP depression's edge), and
- Critical terrestrial habitat (area within 100-750 feet of the VP depression's edge).

Note: See footnote to GC 23. The Corps may determine during the PCN review that a waterbody should not be designated as a VP based on available evidence.

Water diversions: Water diversions are activities such as bypass pumping (e.g., "dam and pump") or water withdrawals. Temporary flume pipes, culverts or cofferdams where normal flows are maintained within the stream boundary's confines aren't water diversions. "Normal flows" are defined as no change in flow from pre-project conditions.

Weir: A barrier across a river designed to alter the flow characteristics. In most cases, weirs take the form of a barrier, smaller than most conventional dams, across a river that causes water to pool behind the structure (not unlike a dam) and allows water to flow over the top. Weirs are commonly used to alter the flow regime of the river, prevent flooding, measure discharge and help render a river navigable.

Waters of the U.S. & Waters of the United States (U.S.): The term waters of the U.S. and all other terms relating to the geographic scope of jurisdiction are defined at 33 CFR 328. Also see Section 502(7) of the Federal CWA [33 USC 1352(7)]. Waters of the U.S. include jurisdictional wetlands. Not all waters and wetlands are jurisdictional. Contact the Corps with any questions regarding jurisdiction.

Navigable waters: Refer to 33 CFR 329. These waters include the following federally designated navigable waters in New England. This list represents only those waterbodies for which affirmative determinations have been made; absence from this list should not be taken as an indication that the waterbody is not navigable:

ME: All tidal waters; Kennebec River to Moosehead Lake; Penobscot River to the confluence of the East and West Branch at Medway, Maine; Lake Umbagog within the State of Maine.

Appendix G: Additional References

1. GC 2: Federal Jurisdictional Boundaries.

(a) Corps Wetlands Delineation Manual, regional supplements, and Corps Wetland Delineation Data Sheets: www.nae.usace.army.mil/missions/regulatory and then “Wetlands and Jurisdictional Limits.”

(b) The USFWS publishes the 1988 National List of Plant Species that Occur in Wetlands (www.nwi.fws.gov).

The Natural Resources Conservation Service (NRCS) publishes the current hydric soil definition, criteria and lists: <http://soils.usda.gov/use/hydric>. For the Field Indicators for Identifying Hydric Soils in N.E., see www.neiwpcc.org/hydricsoils.asp.

2. GC 5: Single and Complete Project.

Single and complete project means the total project proposed or accomplished by one owner/developer or partnership or other association of owners/developers. For example, if construction of a residential development affects several different areas of a headwater or isolated water, or several different headwaters or isolated waters, the cumulative total of all filled areas should be the basis for deciding whether or not the project will be covered by Category 1 or 2.

The *Independent utility* test is used to determine what constitutes a single and complete project in the Corps regulatory program. A project is considered to have independent utility if it would be constructed absent the construction of other projects in the project area. Portions of a multi-phase project that depend upon other phases of the project do not have independent utility. Phases of a project that would be constructed even if the other phases were not built can be considered as separate single and complete projects with independent utility.

3. GC 8: Threatened and Endangered Species.

(a) The following NMFS site must be referenced to ensure that listed species or critical habitat are not present in the action area [GC 8(b)] or to provide information on federally-listed species or habitat [GC 8(e)]: www.nero.noaa.gov/prot_res/esp/ListE&Tspec.pdf. Contact the USFWS for information to check for the presence of listed species (see Appendix D for contact information & procedures).

(b) The Endangered Species Act Consultation Handbook – Procedures for Conducting Section 7 Consultations and Conferences, defines action area as “all areas to be affected directly or indirectly by the federal action and not merely the immediate area involved in the action. [50 CFR 402.02].”

4. GC 42: Essential Fish Habitat.

As part of the GP screening process, the Corps may coordinate with NMFS in accordance with the 1996 amendments to the Magnuson-Stevens Fishery Conservation and Management Act to protect and conserve the habitat of marine, estuarine and anadromous finfish, mollusks, and crustaceans. This habitat is termed “Essential Fish Habitat (EFH)”, and is broadly defined to include “those waters and substrate necessary to fish for spawning, breeding, feeding, or growth to maturity.” There are EFH waters throughout inland and coastal waters in Maine. For additional information, see the EFH regulations 50 CFR 600 at www.nero.noaa.gov/hcd including the “Guide for EFH Descriptions” at www.nero.noaa.gov/hcd/list.htm. Additional information on the location of EFH can be obtained from NMFS (see Appendix D for contact information).

5. GC 4: Avoidance, Minimization and Compensatory Mitigation.

(a) See www.nae.usace.army.mil/missions/regulatory and then “Mitigation” to view the April 10, 2008 “Final Compensatory Mitigation Rule” (33 CFR 332) and related documents. The Q&A document states: “In order to reduce risk and uncertainty and help ensure that the required compensation is provided, the rule establishes a preference hierarchy for mitigation options. The most preferred option

is mitigation bank credits, which are usually in place before the activity is permitted. In-lieu fee program credits are second in the preference hierarchy, because they may involve larger, more ecologically valuable compensatory mitigation projects as compared to permittee-responsible mitigation. Permittee-responsible mitigation is the third option, with three possible circumstances: (1) conducted under a watershed approach, (2) on-site and in kind, and (3) off-site/out-of-kind.

(b) Compensatory mitigation may take the form of wetland preservation, restoration, enhancement, creation, and/or in lieu fee (ILF) for inclusion into the Natural Resources Mitigation Fund for projects in DEP and LURC territories. Avoidance of wetland impacts will reduce the ILF dollar total for applicants. The ILF compensation program was established to provide applicants with a flexible compensation option over and above traditional permittee responsible compensation projects. See the Maine ILF Agreement at www.nae.usace.army.mil/missions/regulatory, “Mitigation” and then “Maine,” or www.maine.gov/dep/blwq/docstand/nrpa/ILF_and_NRCP/index.htm.

6. GCs 24, 15, and 43: Invasive Species.

(a) Information on what are considered “invasive species” is provided in our “Compensatory Mitigation Guidance” document at www.nae.usace.army.mil/missions/regulatory under “Mitigation.” The “Invasive Species” section has a reference to our “Invasive Species Control Plan (ISCP) Guidance” document, located at www.nae.usace.army.mil/missions/regulatory under “Invasive Species,” which provides information on preparing an ISCP.

(b) The June 2009 “Corps of Engineers Invasive Species Policy” is at www.nae.usace.army.mil/missions/regulatory under “Invasive Species” and provides policy, goals and objectives.

7. GC 44: Bank Stabilization.

This generally eliminates bodies of water where the reflected wave energy may interfere with or impact on harbors, marinas, or other developed shore areas. A revetment is sloped and is typically employed to absorb the direct impact of waves more effectively than a vertical seawall. It typically has a less adverse effect on the beach in front of it, abutting properties and wildlife. See the Corps Coastal Engineering Manual [EM 1110-2-1100](http://www.nae.usace.army.mil/missions/regulatory) at www.nae.usace.army.mil/missions/regulatory under “Useful Links and Documents” for design and construction guidance.

8. GC 45: Stream and Wetland Crossings.

(a) Projects should be designed and constructed to ensure long-term success using the most recent manual located at www.nae.usace.army.mil/missions/regulatory under “Stream and River Continuity,” currently “Stream Simulation: An Ecological Approach to Providing Passage for Aquatic Organisms at Road-Stream Crossings, by the U.S. Forest Service.” Section 5.3.3 is of particular importance. Sections 7.5.2.3 Construction Methods and 8.2.11 Stream-Simulation Bed Material Placement both show important steps in the project construction.

(b) For more information on High-Quality Stream Segments and their components see:

i. High-Quality Stream Segments are shown at www.maine.gov/dep/gis/datamaps.

ii. Class A Waters or Class AA Waters:

www.mainelegislature.org/legis/statutes/38/title38sec465.html, and

www.mainelegislature.org/legis/statutes/38/title38sec467.html.

iii. Outstanding river segments www.mainelegislature.org/legis/statutes/38/title38sec480-P.html.

(c) The Massachusetts Dam Removal and the Wetland Regulations offer guidance to evaluate the positive and negative impacts of culvert replacement, including the loss of upstream wetlands, which may be offset by the overall benefits of the river restoration. See

www.nae.usace.army.mil/missions/regulatory and then “Stream and River Continuity.”

(d) The ME DOT’s document “Waterway and Wildlife Crossing Policy and Design Guide for Aquatic Organism, Wildlife Habitat, and Hydrologic Connectivity,” 3rd Edition, July 2008, may be used as guidance to evaluate impacts to aquatic, wildlife and surface water resources when designing, constructing, repairing and maintaining stream crossings. Note: Adherence to this DOT document does not ensure compliance with this GP. Projects must comply with the requirements of this GP including GC 45 and the Corps General Stream Crossing Standards contained therein.

www.maine.gov/mdot/environmental-office-homepage/fishpassage/3rd%20edition%20-%20merged%20final%20version%207-01-08a1.pdf.

(e) GC 45(f): The Skidder Bridge Fact Sheet at www.nae.usace.army.mil/missions/regulatory under “Stream and River Continuity” may be a useful temporary span construction method.

9. GC 45: Wetland Crossings. The Maine DEP’s crossing standards are at 06-096 DEP, Chapter 305: Permits by Rule, 9 & 10) Crossings (utility lines, pipes and cables).
www.maine.gov/dep/blwq/rules/NRPA/2009/305/305_effective_2009.pdf

10. GC 23: Protection of Vernal Pools.

(a) The state’s Significant Wildlife Habitat rules ([Chapter 335](#), Section 9(C) “Habitat management standards for significant vernal pool habitat”) are located at

www.maine.gov/dep/blwq/docstand/nrpapage.htm#rule under “Rules.”

(b) The following documents provide conservation recommendations:

i. Best Development Practices: Conserving pool-breeding amphibians in residential and commercial development in the northeastern U.S., Calhoun and Klemens, 2002. Chapter III, Management Goals and Recommendations, Pages 15 – 26, is particularly relevant. (Available for purchase at www.maineaudubon.org/resource/index.shtml and on Corps website*.)

ii. Science and Conservation of Vernal Pools in Northeastern North America, Calhoun and deMaynadier, 2008. Chapter 12, Conservation Recommendations section, Page 241, is particularly relevant. (Available for purchase via the internet. Chapter 12 is available on Corps website*.)

* www.nae.usace.army.mil/reg under “Vernal Pools.”

(c) Cape Cod Curbing: For smaller roads and driveways, the most important design feature to consider is curbing. Granite curbs and some traditional curbing can act as a barrier to amphibian and hatchling turtle movements. Large numbers of salamanders have been intercepted in their migrations by curbs and catch basins. Use of Cape Cod curbs rather than traditional curbing may be one solution. Alternatively, where storm water management systems require more traditional curbing, it may be possible to design in escape ramps on either side of each catch basin. Cape Cod curbing is shown on Page 35 of the document cited in 10.b.i above. Bituminous material is not required; other materials such as granite are acceptable.

(d) The VP Directional Buffer Guidance document is located at www.nae.usace.army.mil/missions/regulatory under: 1) “State General Permits” and then “Maine,” and 2) “Vernal Pools.”

11. GC 29: Maintenance. River restoration projects that are designed to accommodate the natural dynamic tendencies of the fluvial system are maintained in accordance with the project’s design objectives (Category 1) or the Corps authorization letter (Category 2). These projects are generally designed to support and implement channel assessment and management practices that recognize a stream’s natural dynamic tendencies.

Appendix H: Federal Navigation Projects in Maine

