

Updated 04/28/17

STATE PROJECT

BIDDING INSTRUCTIONS

FOR ALL PROJECTS:

1. Use pen and ink to complete all paper Bids.
2. As a minimum, the following must be received prior to the time of Bid opening:

For a Paper Bid:

- a) a copy of the Notice to Contractors, b) the completed Acknowledgement of Bid Amendments form, c) the completed Schedule of Items, d) two copies of the completed and signed Contract Offer, Agreement & Award form, e) a Bid Guaranty, (if required), and f) any other certifications or Bid requirements listed in the Bid Documents as due by Bid opening.

For an Electronic Bid:

- a) a completed Bid using Expedite® software and submitted via the Bid Express™ web-based service, b) an electronic Bid Guaranty (if required) or a faxed copy of a Bid Bond (with original to be delivered within 72 hours), and c) any other Certifications or Bid requirements listed in the Bid Documents as due by Bid opening.
3. Include prices for all items in the Schedule of Items (excluding non-selected alternates).
4. Bid Guaranty acceptable forms are:
 - a) a properly completed and signed Bid Bond on the Department's prescribed form (or on a form that does not contain any significant variations from the Department's form as determined by the Department) for 5% of the Bid Amount or
 - b) an Official Bank Check, Cashier's Check, Certified Check, U.S. Postal Money Order or Negotiable Certificate of Deposit in the amount stated in the Notice to Contractors or
 - c) an electronic bid bond submitted with an electronic bid.
5. If a paper Bid is to be sent, "FedEx First Overnight" delivery is suggested as the package is delivered directly to the DOT Headquarters Building located at 16 Child Street in Augusta. Other means, such as U.S. Postal Service's Express Mail has proven not to be reliable.

IN ADDITION, FOR FEDERAL AID PROJECTS:

6. Complete the DBE Proposed Utilization form, and submit with your bid. If you are submitting your bid electronically, you must FAX the form to (207) 624-3431. This is a curable defect.

*If you need further information regarding Bid preparation, call the DOT
Contracts Section at (207) 624-3410.*

*For complete bidding requirements, refer to Section 102 of the Maine Department
of Transportation, Standard Specifications, November 2014 Edition.*

NOTICE

The Maine Department of Transportation is attempting to improve the way Bid Amendments/Addendums are handled, and allow for an electronic downloading of bid packages from our website, while continuing to maintain an optional plan holders list.

Prospective bidders, subcontractors or suppliers who wish to download a copy of the bid package and receive a courtesy notification of project specific bid amendments must fill out the on-line plan holder registration form and provide an email address to the MDOT Contracts mailbox at: MDOT.contracts@maine.gov. Each bid package will require a separate request.

Additionally, interested parties will be responsible for reviewing and retrieving the Bid Amendments from our web site, and acknowledging receipt and incorporating those Bid Amendments in their bids using the Acknowledgement of Bid Amendment Form.

The downloading of bid packages from the MDOT website is not the same as providing an electronic bid to the Department. Electronic bids must be submitted via <http://www.BIDX.com>. For information on electronic bidding contact Rebecca Snowden at rebecca.snowden@maine.gov or Diane Barnes at diane.barnes@maine.gov.

NOTICE

For security and other reasons, all Bid Packages which are mailed, shall be provided in double (one envelope inside the other) envelopes. The *Inner Envelope* shall have the following information provided on it:

Bid Enclosed - Do Not Open

PIN:

Town:

Date of Bid Opening:

Name of Contractor with mailing address and telephone number:

In Addition to the usual address information, the *Outer Envelope* should have written or typed on it:

Double Envelope: Bid Enclosed

PIN:

Town:

Date of Bid Opening:

Name of Contractor:

This should not be much of a change for those of you who use Federal Express or similar services.

Hand-carried Bids may be in one envelope as before, and should be marked with the following information:

Bid Enclosed: Do Not Open

PIN:

Town:

Name of Contractor:

October 16, 2001

STATE OF MAINE DEPARTMENT OF TRANSPORTATION
Bid Guaranty-Bid Bond Form

KNOW ALL MEN BY THESE PRESENTS THAT _____

_____ of the City/Town of _____ and State of _____

as Principal, and _____ as Surety, a

Corporation duly organized under the laws of the State of _____ and having a usual place of

Business in _____ and hereby held and firmly bound unto the Treasurer of

the State of Maine in the sum of _____ for payment which Principal and Surety bind

themselves, their heirs, executors, administrators, successors and assigns, jointly and severally.

The condition of this obligation is that the Principal has submitted to the Maine Department of

Transportation, hereafter Department, a certain bid, attached hereto and incorporated as a

part herein, to enter into a written contract for the construction of _____

_____ and if the Department shall accept said bid

and the Principal shall execute and deliver a contract in the form attached hereto (properly

completed in accordance with said bid) and shall furnish bonds for this faithful performance of

said contract, and for the payment of all persons performing labor or furnishing material in

connection therewith, and shall in all other respects perform the agreement created by the

acceptance of said bid, then this obligation shall be null and void; otherwise it shall remain in full

force, and effect.

Signed and sealed this _____ day of _____ 20_____

WITNESS:

WITNESS

PRINCIPAL:

By _____

By: _____

By: _____

SURETY:

By _____

By: _____

Name of Local Agency: _____

NOTICE

Bidders:

Please use the attached “Request for Information” form when submitting questions concerning specific Contracts that have been advertised for Bid, include additional numbered pages as required. RFI’s may be faxed to 207-624-3431, submitted electronically through the Departments web page of advertised projects by selecting the RFI tab on the project details page or via e-mail to RFI-Contracts.MDOT@maine.gov.

These are the only allowable mechanisms for answering Project specific questions. MaineDOT will not be bound to any answers to Project specific questions received during the Bidding phase through other processes.

When submitting RFIs by Email please follow the same guidelines as stated on the “Request for Information” form and include the word “RFI” along with the Project name and Identification number in the subject line.

Vendor Registration

Prospective Bidders must register as a vendor with the Department of Administrative & Financial Services if the vendor is awarded a contract. Vendors will not be able to receive payment without first being registered. Vendors/Contractors will find information and register through the following link –

<http://www.maine.gov/purchases/venbid/index.shtml>

**STATE OF MAINE DEPARTMENT OF TRANSPORTATION
NOTICE TO CONTRACTORS**

Sealed Bids addressed to the Maine Department of Transportation, Augusta, Maine 04333 and endorsed on the wrapper "Bids for Crack Sealing and Crack Repair in the Towns of Blue Hill, Penobscot, Orland, Dover-Foxcroft, & Sebec" will be received from contractors at the Reception Desk, MaineDOT Building, Capitol Street, Augusta, Maine, until 11:00 o'clock A.M. (prevailing time) on April 22, 2020 and at that time and place, publicly opened and read. Bids will be accepted from all bidders. The lowest responsive bidder must demonstrate successful completion of projects of similar size and scope to be considered for the award of this contract. **We now accept electronic bids for bid packages posted on the bidx.com website. Electronic bids do not have to be accompanied by paper bids. Please note: The Department will accept a facsimile of the bid bond; however, the original bid bond must then be received at the MDOT Contract Section within 72 hours of the bid opening.** Until further notice, dual bids (one paper, one electronic) will be accepted, with the paper copy taking precedence.

Description: State Project 18995.43, WIN 18995.43.

Location: In Hancock and Piscataquis Counties: Priority 1 is located on Route 15 beginning 0.05 of a mile north of the Hinckley Hill Road in Blue Hill and extending northerly 7.99 miles to the intersection of U.S. Route 1 and State Route 15 in Orland. Priority 2 is located on Route 15 in Dover-Foxcroft beginning 0.97 of a mile north of intersection of Norton Hill road and extending northerly on Route 15 for 3.76 miles. Priority 3 is located on Route 6 beginning 0.15 of a mile northeast of intersection of Free Street in Dover-Foxcroft and extending northeasterly 6.40 miles. Ending at 0.3 of a mile west of intersection of Milo Road, Village Road and Stagecoach Road in Sebec.

Outline of Work: Crack Sealing, Crack Repair and other incidental work.

For general information regarding Bidding and Contracting procedures, contact George Macdougall at (207) 624-3410. Our webpage at <http://www.maine.gov/mdot/contractors/> contains a copy of the Schedule of Items, Plan Holders List, written portions of bid amendments, drawings, bid results and an electronic form for RFI submittal. For Project-specific information fax all questions to **George Macdougall** at (207) 624-3431, use electronic RFI form or email questions to RFI-Contracts.MDOT@maine.gov, project name and identification number should be in the subject line. Questions received after 12:00 noon of Monday (or if that Monday is a state holiday, Friday) prior to bid date will not be answered. Bidders shall not contact any other Departmental staff for clarification of Contract provisions, and the Department will not be responsible for any interpretations so obtained. TTY users call Maine Relay 711.

Specifications and bid forms may be seen at the MaineDOT Building in Augusta, Maine and at the Department of Transportation's Regional Office in Bangor. They may be purchased from the Department between the hours of 8:00 a.m. to 4:30 p.m. by cash, credit card (Visa/Mastercard) or check payable to Treasurer, State of Maine sent to Maine Department of Transportation, Attn.: Mailroom, 16 State House Station, Augusta, Maine 04333-0016. They also may be purchased by telephone at (207) 624-3536 between the hours of 8:00 a.m. to 4:30 p.m. Bid Book \$10 (\$13 by mail), payment in advance, all non-refundable.

Each Bid must be made upon blank forms provided by the Department and must be accompanied by a bid bond at 5% of the bid amount or an official bank check, cashier's check, certified check, certificate of deposit, or United States postal money order in the amount of **\$5,000** payable to Treasurer, State of Maine as a Bid guarantee. A Contract Performance Surety Bond and a Contract Payment Surety Bond, each in the amount of 100 percent of the Contract price, will be required of the successful Bidder.

This Contract is subject to all applicable State Laws.

All work shall be governed by *State of Maine, Department of Transportation, Standard Specifications, November 2014 Edition*, price \$10 [\$15 by mail], and *Standard Details, November 2014 Edition*, price \$10 [\$15 by mail]. They also may be purchased by telephone at (207) 624-3536 between the hours of 8:00 a.m. to 4:30 p.m. *Standard Detail* updates can be found at <http://www.maine.gov/mdot/contractors/publications/>.

The right is hereby reserved to the MaineDOT to reject any or all bids.

Augusta, Maine
April 1, 2020

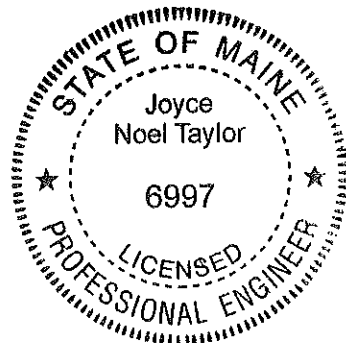

JOYCE NOEL TAYLOR P. E.
CHIEF ENGINEER

**SPECIAL PROVISION 102.7.3
ACKNOWLEDGMENT OF BID AMENDMENTS**

With this form, the Bidder acknowledges its responsibility to check for all Amendments to the Bid Package. For each Project under Advertisement, Amendments are located at <http://www.maine.gov/mdot/contractors/> . It is the responsibility of the Bidder to determine if there are Amendments to the Project, to download them, to incorporate them into their Bid Package, and to reference the Amendment number and the date on the form below. The Maine DOT will not post Bid Amendments any later than noon the day before Bid opening without individually notifying all the planholders.

Amendment Number	Date

The Contractor, for itself, its successors and assigns, hereby acknowledges that it has received all of the above referenced Amendments to the Bid Package.

CONTRACTOR

Date

Signature of authorized representative

(Name and Title Printed)

Maine Department of Transportation

Proposal Schedule of Items

Proposal ID: 018995.43

Project(s): 018995.43

SECTION: 1 HIGHWAY ITEMS

Alt Set ID:

Alt Mbr ID:

Contractor: _____

Proposal Line Number	Item ID Description	Approximate Quantity and Units	Unit Price		Bid Amount	
			Dollars	Cents	Dollars	Cents
0010	424.24 ASPHALT RUBBER CRACK SEALER TYPE 4, APPLIED	17,730.000 LB	_____	 _____	_____	 _____
0020	424.38 CRACK REPAIR - HOT POUR MASTIC	10,890.000 LB	_____	 _____	_____	 _____
0030	659.10 MOBILIZATION	LUMP SUM		LUMP SUM	_____	 _____
		Section: 1		Total:	_____	 _____
				Total Bid:	_____	 _____

CONTRACT AGREEMENT, OFFER & AWARD

AGREEMENT made on the date last signed below, by and between the State of Maine, acting through and by its Department of Transportation (Department), an agency of state government with its principal administrative offices located at Child Street, Augusta, Maine, with a mailing address at 16 State House Station, Augusta, Maine 04333-0016, and _____ a corporation or other legal entity organized under the laws of the State of _____, with its principal place of business located at _____

The Department and the Contractor, in consideration of the mutual promises set forth in this Agreement (the “Contract”), hereby agree as follows:

A. The Work.

The Contractor agrees to complete all Work as specified or indicated in the Contract including Extra Work in conformity with the Contract, **WIN 18995.43 for the Crack Sealing and Crack Repair in the Towns of Blue Hill, Penobscot, Orland, Dover-Foxcroft, & Sebec, Counties of Hancock and Piscataquis, Maine.** The Work includes construction, maintenance during construction, warranty as provided in the Contract, and other incidental work.

The Contractor shall be responsible for furnishing all supervision, labor, equipment, tools supplies, permanent materials and temporary materials required to perform the Work including construction quality control including inspection, testing and documentation, all required documentation at the conclusion of the project, warranting its work and performing all other work indicated in the Contract.

The Department shall have the right to alter the nature and extent of the Work as provided in the Contract; payment to be made as provided in the same.

B. Time.

The Contractor agrees to complete all Work, except warranty work, within **15** Working Days. Further, the Department may deduct from moneys otherwise due the Contractor, not as a penalty, but as Liquidated Damages in accordance with Sections 107.7 and 107.8 of the *State of Maine Department of Transportation Standard Specifications, November 2014 Edition* and related Special Provisions.

C. Price.

The quantities given in the Schedule of Items of the Bid Package will be used as the basis for determining the original Contract amount and for determining the amounts of the required Performance Surety Bond and Payment Surety Bond, and that the amount of this offer is _____

_____ Performance Bond and Payment Bond each being 100% of the amount of this Contract.

D. Contract.

This Contract, which may be amended, modified, or supplemented in writing only, consists of the Contract documents as defined in the Plans, *Standard Specifications, November 2014 Edition, Standard Details November 2014 Edition* as updated through advertisement, Supplemental Specifications, Special Provisions, Contract Agreement; and Contract Bonds. It is agreed and understood that this Contract will be governed by the documents listed above.

E. Certifications.

By signing below, the Contractor hereby certifies that to the best of the Contractor's knowledge and belief:

1. All of the statements, representations, covenants, and/or certifications required or set forth in the Bid and the Bid Documents, including those in the Contract are still complete and accurate as of the date of this Agreement.
2. The Contractor knows of no legal, contractual, or financial impediment to entering into this Contract.
3. The person signing below is legally authorized by the Contractor to sign this Contract on behalf of the Contractor and to legally bind the Contractor to the terms of the Contract.

F. Offer.

The undersigned, having carefully examined the site of work, the Plans, *Standard Specifications November 2014 Edition*, *Standard Details November 2014 Edition* as updated through advertisement, Supplemental Specifications, Special Provisions, Contract Agreement; and Contract Bonds contained herein for construction of **WIN 18995.43 for the Crack Sealing and Crack Repair in the Towns of Blue Hill, Penobscot, Orland, Dover-Foxcroft, & Sebec, Counties of Hancock and Piscataquis**, State of Maine, on which bids will be received until the time specified in the “Notice to Contractors” do(es) hereby bid and offer to enter into this contract to supply all the materials, tools, equipment and labor to construct the whole of the Work in strict accordance with the terms and conditions of this Contract at the unit prices in the attached “Schedule of Items.”

The Offeror agrees to perform the work required at the price specified above and in accordance with the bids provided in the attached “Schedule of Items” in strict accordance with the terms of this solicitation, and to provide the appropriate insurance and bonds if this offer is accepted by the Government in writing.

As Offeror also agrees:

First: To do any extra work, not covered by the attached “Schedule of Items,” which may be ordered by the Resident, and to accept as full compensation the amount determined upon a “Force Account” basis as provided in the *Standard Specifications, November 2014 Edition*, and as addressed in the contract documents.

Second: That the bid bond at 5% of the bid amount or the official bank check, cashier’s check, certificate of deposit or U. S. Postal Money Order in the amount given in the “Notice to Contractors”, payable to the Treasurer of the State of Maine and accompanying this bid, shall be forfeited, as liquidated damages, if in case this bid is accepted, and the undersigned shall fail to abide by the terms and conditions of the offer and fail to furnish satisfactory insurance and Contract bonds under the conditions stipulated in the Specifications within 15 days of notice of intent to award the contract.

Third: To begin the Work as stated in Section 107.2 of the *Standard Specifications November 2014 Edition* and complete the Work within the time limits given in the Special Provisions of this Contract.

Fourth: That this offer shall remain open for 30 calendar days after the date of opening of bids.

Fifth: The Bidder hereby certifies, to the best of its knowledge and belief that: the Bidder has not, either directly or indirectly, entered into any agreement, participated in any collusion, or otherwise taken any action in restraint of competitive bidding in connection with its bid, and its subsequent contract with the Department.

IN WITNESS WHEREOF, the Contractor, for itself, its successors and assigns, hereby execute two duplicate originals of this Agreement and thereby binds itself to all covenants, terms, and obligations contained in the Contract Documents.

CONTRACTOR

Date

(Signature of Legally Authorized Representative
of the Contractor)

Witness

(Name and Title Printed)

G. Award.

Your offer is hereby accepted. This award consummates the Contract, and the documents referenced herein.

MAINE DEPARTMENT OF TRANSPORTATION

Date

By: Bruce A. Van Note, Commissioner

Witness

CONTRACT AGREEMENT, OFFER & AWARD

AGREEMENT made on the date last signed below, by and between the State of Maine, acting through and by its Department of Transportation (Department), an agency of state government with its principal administrative offices located at Child Street, Augusta, Maine, with a mailing address at 16 State House Station, Augusta, Maine 04333-0016, and _____ a corporation or other legal entity organized under the laws of the State of _____, with its principal place of business located at _____

The Department and the Contractor, in consideration of the mutual promises set forth in this Agreement (the “Contract”), hereby agree as follows:

A. The Work.

The Contractor agrees to complete all Work as specified or indicated in the Contract including Extra Work in conformity with the Contract, **WIN 18995.43 for the Crack Sealing and Crack Repair in the Towns of Blue Hill, Penobscot, Orland, Dover-Foxcroft, & Sebec, Counties of Hancock and Piscataquis, Maine.** The Work includes construction, maintenance during construction, warranty as provided in the Contract, and other incidental work.

The Contractor shall be responsible for furnishing all supervision, labor, equipment, tools supplies, permanent materials and temporary materials required to perform the Work including construction quality control including inspection, testing and documentation, all required documentation at the conclusion of the project, warranting its work and performing all other work indicated in the Contract.

The Department shall have the right to alter the nature and extent of the Work as provided in the Contract; payment to be made as provided in the same.

B. Time.

The Contractor agrees to complete all Work, except warranty work, within **15** Working Days. Further, the Department may deduct from moneys otherwise due the Contractor, not as a penalty, but as Liquidated Damages in accordance with Sections 107.7 and 107.8 of the *State of Maine Department of Transportation Standard Specifications, November 2014 Edition* and related Special Provisions.

C. Price.

The quantities given in the Schedule of Items of the Bid Package will be used as the basis for determining the original Contract amount and for determining the amounts of the required Performance Surety Bond and Payment Surety Bond, and that the amount of this offer is _____

_____ Performance Bond and Payment Bond each being 100% of the amount of this Contract.

D. Contract.

This Contract, which may be amended, modified, or supplemented in writing only, consists of the Contract documents as defined in the Plans, *Standard Specifications, November 2014 Edition, Standard Details November 2014 Edition* as updated through advertisement, Supplemental Specifications, Special Provisions, Contract Agreement; and Contract Bonds. It is agreed and understood that this Contract will be governed by the documents listed above.

E. Certifications.

By signing below, the Contractor hereby certifies that to the best of the Contractor's knowledge and belief:

1. All of the statements, representations, covenants, and/or certifications required or set forth in the Bid and the Bid Documents, including those in the Contract are still complete and accurate as of the date of this Agreement.
2. The Contractor knows of no legal, contractual, or financial impediment to entering into this Contract.
3. The person signing below is legally authorized by the Contractor to sign this Contract on behalf of the Contractor and to legally bind the Contractor to the terms of the Contract.

F. Offer.

The undersigned, having carefully examined the site of work, the Plans, *Standard Specifications November 2014 Edition*, *Standard Details November 2014 Edition* as updated through advertisement, Supplemental Specifications, Special Provisions, Contract Agreement; and Contract Bonds contained herein for construction of **WIN 18995.43 for the Crack Sealing and Crack Repair in the Towns of Blue Hill, Penobscot, Orland, Dover-Foxcroft, & Sebec, Counties of Hancock and Piscataquis**, State of Maine, on which bids will be received until the time specified in the “Notice to Contractors” do(es) hereby bid and offer to enter into this contract to supply all the materials, tools, equipment and labor to construct the whole of the Work in strict accordance with the terms and conditions of this Contract at the unit prices in the attached “Schedule of Items.”

The Offeror agrees to perform the work required at the price specified above and in accordance with the bids provided in the attached “Schedule of Items” in strict accordance with the terms of this solicitation, and to provide the appropriate insurance and bonds if this offer is accepted by the Government in writing.

As Offeror also agrees:

First: To do any extra work, not covered by the attached “Schedule of Items,” which may be ordered by the Resident, and to accept as full compensation the amount determined upon a “Force Account” basis as provided in the *Standard Specifications, November 2014 Edition*, and as addressed in the contract documents.

Second: That the bid bond at 5% of the bid amount or the official bank check, cashier’s check, certificate of deposit or U. S. Postal Money Order in the amount given in the “Notice to Contractors”, payable to the Treasurer of the State of Maine and accompanying this bid, shall be forfeited, as liquidated damages, if in case this bid is accepted, and the undersigned shall fail to abide by the terms and conditions of the offer and fail to furnish satisfactory insurance and Contract bonds under the conditions stipulated in the Specifications within 15 days of notice of intent to award the contract.

Third: To begin the Work as stated in Section 107.2 of the *Standard Specifications November 2014 Edition* and complete the Work within the time limits given in the Special Provisions of this Contract.

Fourth: That this offer shall remain open for 30 calendar days after the date of opening of bids.

Fifth: The Bidder hereby certifies, to the best of its knowledge and belief that: the Bidder has not, either directly or indirectly, entered into any agreement, participated in any collusion, or otherwise taken any action in restraint of competitive bidding in connection with its bid, and its subsequent contract with the Department.

IN WITNESS WHEREOF, the Contractor, for itself, its successors and assigns, hereby execute two duplicate originals of this Agreement and thereby binds itself to all covenants, terms, and obligations contained in the Contract Documents.

CONTRACTOR

Date

(Signature of Legally Authorized Representative
of the Contractor)

Witness

(Name and Title Printed)

G. Award.

Your offer is hereby accepted. This award consummates the Contract, and the documents referenced herein.

MAINE DEPARTMENT OF TRANSPORTATION

Date

By: Bruce A. Van Note, Commissioner

Witness

CONTRACT AGREEMENT, OFFER & AWARD

AGREEMENT made on the date last signed below, by and between the State of Maine, acting through and by its Department of Transportation (Department), an agency of state government with its principal administrative offices located at Child Street Augusta, Maine, with a mailing address at 16 State House Station, Augusta, Maine 04333-0016, and
(Name of the firm bidding the job)
a corporation or other legal entity organized under the laws of the State of Maine, with its principal place of business located at (address of the firm bidding the job)

The Department and the Contractor, in consideration of the mutual promises set forth in this Agreement (the "Contract"), hereby agree as follows:

A. The Work.

The Contractor agrees to complete all Work as specified or indicated in the Contract including Extra Work in conformity with the Contract, PIN No. 1224.00, for the Hot Mix Asphalt Overlay in the town/city of South Nowhere, County of Washington, Maine. The Work includes construction, maintenance during construction, warranty as provided in the Contract, and other incidental work.

The Contractor shall be responsible for furnishing all supervision, labor, equipment, tools supplies, permanent materials and temporary materials required to perform the Work including construction quality control including inspection, testing and documentation, all required documentation at the conclusion of the project, warranting its work and performing all other work indicated in the Contract.

The Department shall have the right to alter the nature and extent of the Work as provided in the Contract; payment to be made as provided in the same.

B. Time.

The Contractor agrees to complete all Work, except warranty work, on or before November 15, 2006. Further, the Department may deduct from moneys otherwise due the Contractor, not as a penalty, but as Liquidated Damages in accordance with Sections 107.7 and 107.8 of the State of Maine Department of Transportation Standard Specifications, Revision of December 2002 and related Special Provisions.

C. Price.

The quantities given in the Schedule of Items of the Bid Package will be used as the basis for determining the original Contract amount and for determining the amounts of the required Performance Surety Bond and Payment Surety Bond, and that the amount of this offer is (Place bid here in alphabetical form such as One Hundred and Two dollars and 10 cents)
\$ (repeat bid here in numerical terms, such as \$102.10) Performance Bond and Payment Bond each being 100% of the amount of this Contract.

D. Contract.

This Contract, which may be amended, modified, or supplemented in writing only, consists of the Contract documents as defined in the Plans, Standard Specifications, Revision of December 2002, Standard Details Revision of December 2002, Supplemental Specifications, Special Provisions, Contract Agreement; and Contract Bonds. It is agreed and understood that this Contract will be governed by the documents listed above.

E. Certifications.

By signing below, the Contractor hereby certifies that to the best of the Contractor's knowledge and belief:

1. All of the statements, representations, covenants, and/or certifications required or set forth in the Bid and the Bid Documents, including those in Appendix A to Division 100 of the Standard Specifications Revision of December 2002 (Federal Contract Provisions Supplement), and the Contract are still complete and accurate as of the date of this Agreement.
2. The Contractor knows of no legal, contractual, or financial impediment to entering into this Contract.
3. The person signing below is legally authorized by the Contractor to sign this Contract on behalf of the Contractor and to legally bind the Contractor to the terms of the Contract.

F. Offer.

The undersigned, having carefully examined the site of work, the Plans, Standard Specifications, Revision of December 2002, Standard Details Revision of December 2002, Supplemental Specifications, Special Provisions, Contract Agreement; and Contract Bonds contained herein for construction of:

PIN 1234.00 South Nowhere, Hot Mix Asphalt Overlay

State of Maine, on which bids will be received until the time specified in the "Notice to Contractors" do(es) hereby bid and offer to enter into this contract to supply all the materials, tools, equipment and labor to construct the whole of the Work in strict accordance with the terms and conditions of this Contract at the unit prices in the attached "Schedule of Items".

The Offeror agrees to perform the work required at the price specified above and in accordance with the bids provided in the attached "Schedule of Items" in strict accordance with the terms of this solicitation, and to provide the appropriate insurance and bonds if this offer is accepted by the Government in writing.

As Offeror also agrees:

First: To do any extra work, not covered by the attached "Schedule of Items", which may be ordered by the Resident, and to accept as full compensation the amount determined upon a "Force Account" basis as provided in the Standard Specifications, Revision of December 2002, and as addressed in the contract documents.

Second: That the bid bond at 5% of the bid amount or the official bank check, cashier's check, certificate of deposit or U. S. Postal Money Order in the amount given in the "Notice to Contractors", payable to the Treasurer of the State of Maine and accompanying this bid, shall be forfeited, as liquidated damages, if in case this bid is accepted, and the undersigned shall fail to abide by the terms and conditions of the offer and fail to furnish satisfactory insurance and Contract bonds under the conditions stipulated in the Specifications within 15 days of notice of intent to award the contract.

Third: To begin the Work as stated in Section 107.2 of the Standard Specifications Revision of 2002 and complete the Work within the time limits given in the Special Provisions of this Contract.

Fourth: The Contractor will be bound to the Disadvantaged Business Enterprise (DBE) Requirements contained in the attached Notice (Additional Instructions to Bidders) and submit a completed Contractor's Disadvantaged Business Enterprise Utilization Plan with their bid.

Fifth: That this offer shall remain open for 30 calendar days after the date of opening of bids.

Sixth: The Bidder hereby certifies, to the best of its knowledge and belief that: the Bidder has not, either directly or indirectly, entered into any agreement, participated in any collusion, or otherwise taken any action in restraint of competitive bidding in connection with its bid, and its subsequent contract with the Department.

IN WITNESS WHEREOF, the Contractor, for itself, its successors and assigns, hereby execute two duplicate originals of this Agreement and thereby binds itself to all covenants, terms, and obligations contained in the Contract Documents.

Date

(Witness Sign Here)
Witness

(Sign Here)
(Signature of Legally Authorized Representative of the Contractor)

(Print Name Here)
(Name and Title Printed)

CONTRACTOR

G. Award.

Your offer is hereby accepted.

This award consummates the Contract, and the documents referenced herein.

MAINE DEPARTMENT OF TRANSPORTATION

Date

By: David Bernhardt, Commissioner

(Witness)

BOND

CONTRACT PERFORMANCE BOND
(Surety Company Form)

KNOW ALL MEN BY THESE PRESENTS: That _____
_____ in the State of _____, as principal,
and _____,
a corporation duly organized under the laws of the State of _____ and having a
usual place of business _____,
as Surety, are held and firmly bound unto the Treasurer of the State of Maine in the sum
of _____ and 00/100 Dollars (\$ _____),
to be paid said Treasurer of the State of Maine or his successors in office, for which
payment well and truly to be made, Principal and Surety bind themselves, their heirs,
executors and administrators, successors and assigns, jointly and severally by these
presents.

The condition of this obligation is such that if the Principal designated as Contractor in
the Contract to construct Project Number _____ in the Municipality of
_____ promptly and faithfully performs the Contract, then this
obligation shall be null and void; otherwise it shall remain in full force and effect.

The Surety hereby waives notice of any alteration or extension of time made by the State
of Maine.

Signed and sealed this _____ day of _____, 20_____

WITNESSES: SIGNATURES:

CONTRACTOR:

Signature.....

Print Name Legibly Print Name Legibly

SURETY:

Signature

Print Name Legibly Print Name Legibly

SURETY ADDRESS:

.....

.....

.....

TELEPHONE.....

BOND # _____

CONTRACT PAYMENT BOND
(Surety Company Form)

KNOW ALL MEN BY THESE PRESENTS: That _____
_____ **in the State of** _____, as principal,
and.....
a corporation duly organized under the laws of the State of and having a
usual place of business in
as Surety, are held and firmly bound unto the Treasurer of the State of Maine for the use
and benefit of claimants as herein below defined, in the sum of _____
_____ **and 00/100 Dollars (\$** _____ **)**
for the payment whereof Principal and Surety bind themselves, their heirs, executors and
administrators, successors and assigns, jointly and severally by these presents.

The condition of this obligation is such that if the Principal designated as Contractor in
the Contract to construct Project Number _____ in the Municipality of
_____ promptly satisfies all claims and demands incurred for all
labor and material, used or required by him in connection with the work contemplated by
said Contract, and fully reimburses the obligee for all outlay and expense which the
obligee may incur in making good any default of said Principal, then this obligation shall
be null and void; otherwise it shall remain in full force and effect.

A claimant is defined as one having a direct contract with the Principal or with a
Subcontractor of the Principal for labor, material or both, used or reasonably required for
use in the performance of the contract.

Signed and sealed this _____ day of _____, 20 .. .

WITNESS: SIGNATURES:

CONTRACTOR:

Signature.....

Print Name Legibly

SURETY:

Signature.....

Print Name Legibly

SURETY ADDRESS:

NAME OF LOCAL AGENCY:

..... ADDRESS

TELEPHONE

NOTICE TO CONTRACTORS - PREFERRED EMPLOYEES

Sec. 1303. Public Works; minimum wage

In the employment of laborers in the construction of public works, including state highways, by the State or by persons contracting for the construction, preference must first be given to citizens of the State who are qualified to perform the work to which the employment relates and, if they can not be obtained in sufficient numbers, then to citizens of the United States. Every contract for public works construction must contain a provision for employing citizens of this State or the United States. The hourly wage and benefit rate paid to laborers employed in the construction of public works, including state highways, may not be less than the fair minimum rate as determined in accordance with section 1308. Any contractor who knowingly and willfully violates this section is subject to a fine of not less than \$250 per employee violation. Each day that any contractor employs a laborer at less than the wage and benefit minimum stipulated in this section constitutes a separate violation of this section. [1997, c. 757, §1 (amd).]

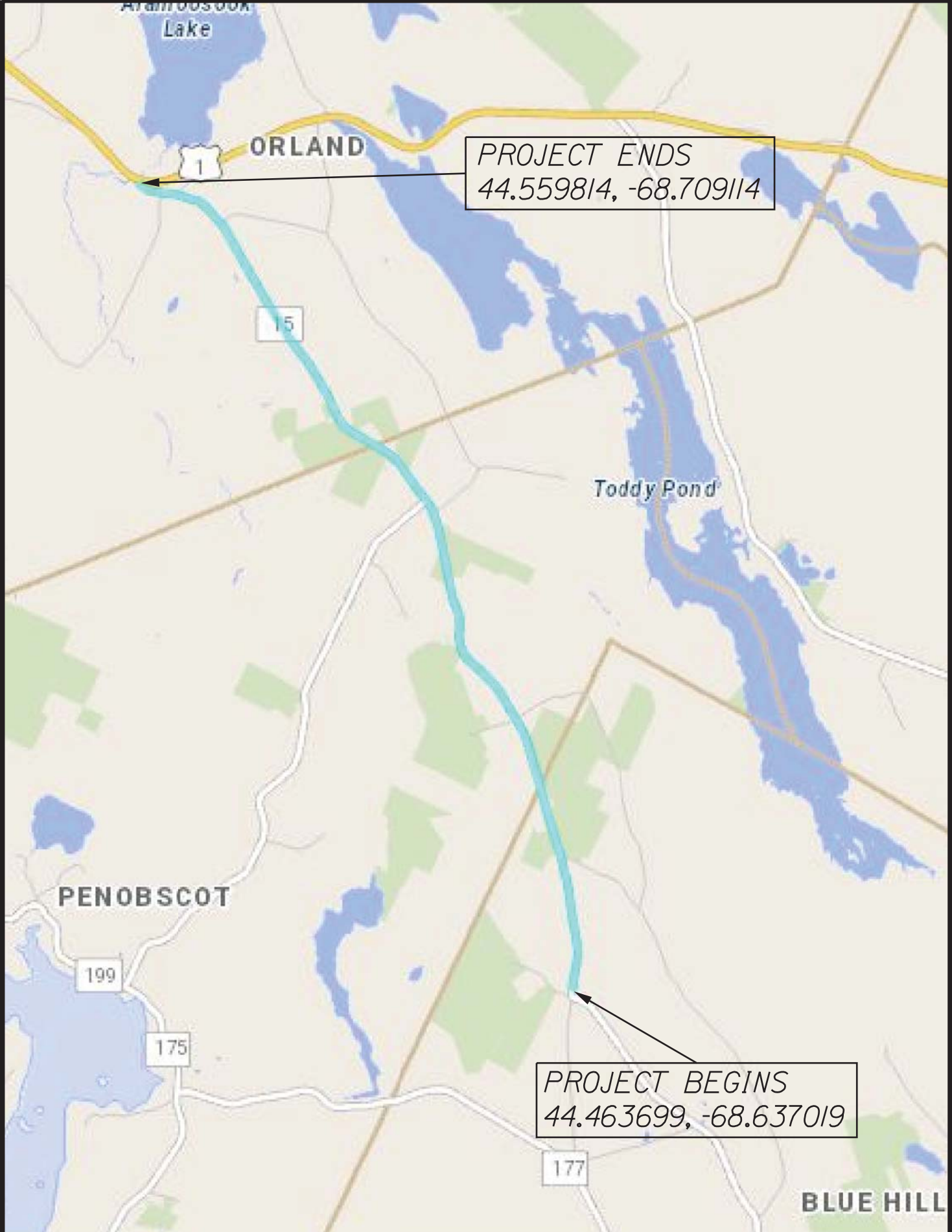

PROJECT ENDS
44.559814, -68.709114

PROJECT BEGINS
44.463699, -68.637019

STATE OF MAINE
DEPARTMENT OF TRANSPORTATION

ROUTE 15 BLUE HILL, ORLAND
HANCOCK COUNTY

SHEET NUMBER

1 28

WIN 18995.43

PLANS

OF 1

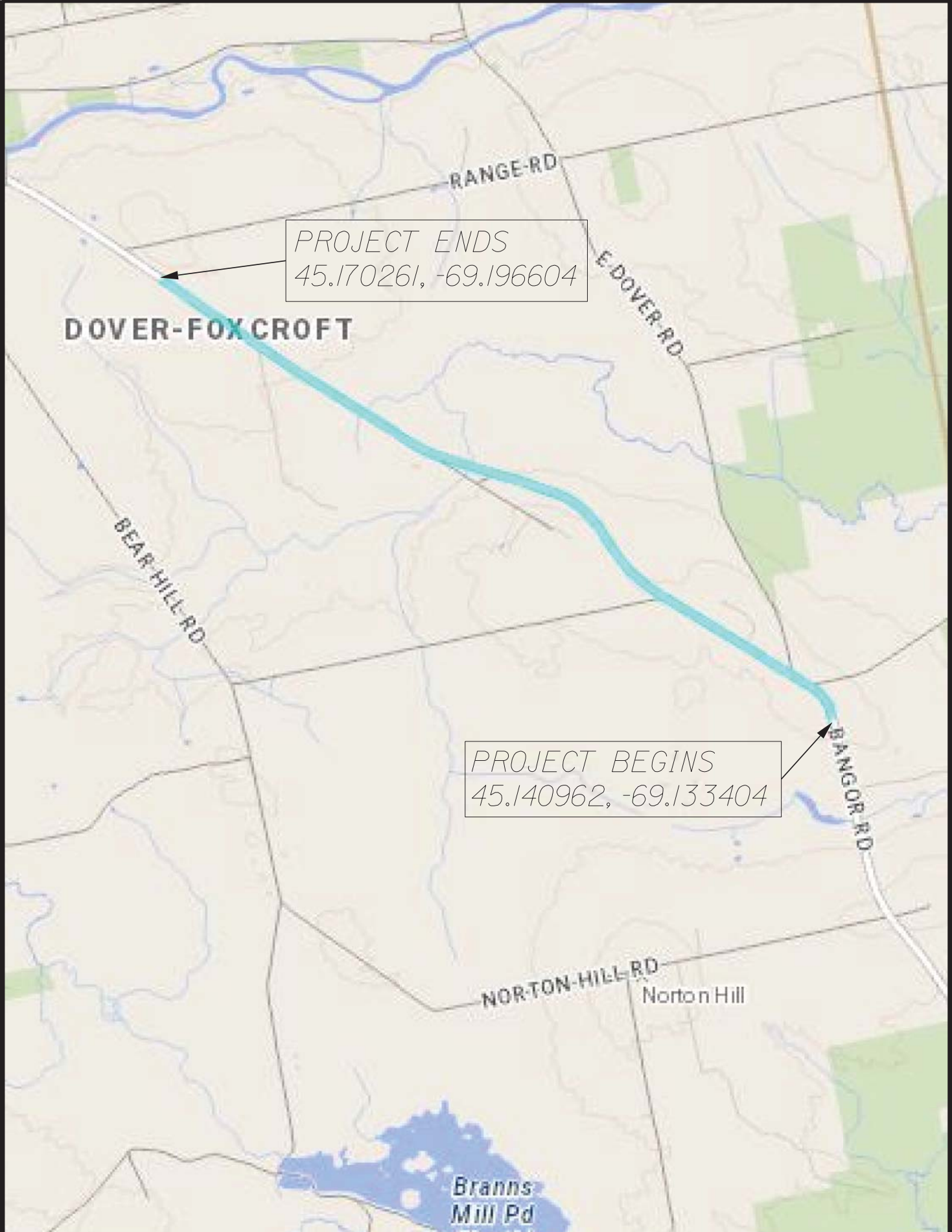

STATE OF MAINE
DEPARTMENT OF TRANSPORTATION

ROUTE 15 DOVER-FOXCROFT
PISCATAQUIS COUNTY

SHEET NUMBER
1 29

WIN 18995.43

PLANS

OF 1

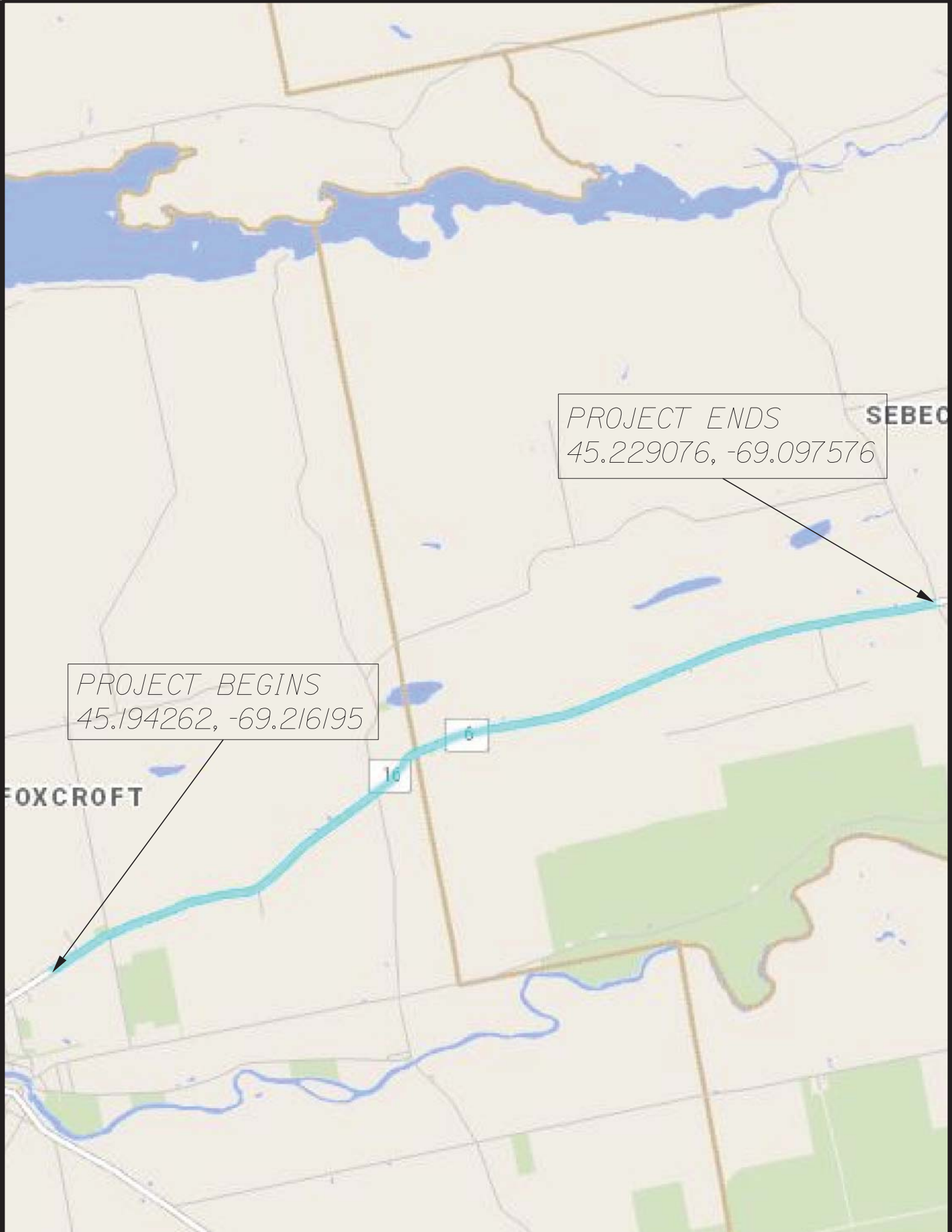

STATE OF MAINE
DEPARTMENT OF TRANSPORTATION

ROUTE 6 DOVER-FOX CROFT, SEBEC
PISCATAQUIS COUNTY

SHEET NUMBER
1 30

WIN 18995.43

PLANS

OF 1

CONSTRUCTION NOTES

Item 424.24 Asphalt Rubber Crack Sealer, Applied

Locations & Priority:

1. Blue Hill – Orland, Route 15

- Beginning 0.05 of a mile north of the Hinckley Hill Road and extending northerly 7.99 miles to the intersection of U.S. Route 1 and State Route 15.

2. Dover Foxcroft, Route 15

- Beginning 0.97 of a mile north of intersection of Norton Hill road and extending northerly on Route 15 for 3.76 miles.

3. Dover Foxcroft – Sebec, Route 6

- Beginning 0.15 of a mile northeast of intersection of Free Street, extending northeasterly 6.40 miles. Ending at 0.3 of a mile west of intersection of Milo Road, Village Road and Stagecoach Road.

Item 424.38 Crack Repair-Hot Pour Mastic

- This item shall be used on longitudinal cracks over 1” wide, or as directed by the Resident.

Locations & Priority:

1. Blue Hill – Orland, Route 15

- Beginning 0.15 of a mile south of the Hinckley Hill Road and extending northerly 7.24 miles.

2. Dover Foxcroft, Route 15

- Beginning 0.15 of a mile northeast of Free Street extending northeasterly 6.40 miles, ending 0.03 of a mile west of intersection of Milo Road, Village Road and Stagecoach Road.

Notes:

1. The Contractor shall crack seal the travel lanes (from centerline out to and including the white edge line and/or longitudinal joint between travel lane and shoulder), and transverse cracking on shoulders unless directed otherwise by the Resident.
2. Any damage to the slopes caused by the Contractor's equipment, personnel, or operation shall be repaired to the satisfaction of the Resident. All work, equipment, and materials required to make repairs shall be at the Contractor's expense.
3. MaineDOT may delete any portion of the work at any time due to unforeseen circumstances, conditions not favorable for crack sealing, or once the estimated quantity is reached.

SPECIAL PROVISION
SECTION 101
CONTRACT INTERPRETATION
(Working Day – Pavement Preservation)

Add the following to 101.2 – Definitions:

Weather Event Any precipitation, such as rain, sleet, snow, or fog that causes wet pavement that prevents the contractor from completing work within the Construction Limits as determined by the Department. This excludes ambient air temperatures below Specification.

Weather Dependent Activities Contractor scheduled work that cannot be completed should a Weather Event occur. Paving or other activities as determined by the Department will be considered Weather Dependent Activities.

Working Day Any Calendar Day except:

- Identified non-work days in the Contract Special Provision 107
- Saturdays, Sundays and Holidays – as outlined in Section 107.3.3
- The period from November 15th to April 15th, inclusive
- Any day a Weather Event prevents the Contractor from performing at least seven hours of weather dependent activities, as determined by the Department. Up to a three-hour hold prior to the start of work may be required if weather conditions are uncertain.

The Contractor may request, in writing, a non-working day due to a Weather Event up to 16 hours in advance of the normal start time. The Department may approve this request depending on the certainty of the forecast.

If the Contractor elects to work a Saturday, an allowable holiday, or receives approval to work Sunday, the same process will be utilized to determine if it is a Working Day.

If the Contractor requests approval to work Saturday and does not cancel their request by Thursday at the end of shift, that Saturday will be considered a Working Day regardless of the actual weather conditions and whether work occurred.

SPECIAL PROVISIONS
SECTION 104
Utilities

There are no Utility or Railroad conflicts anticipated with this project.

The Contractor shall take precautions to prevent any sealing material from flowing into any utility facilities such as manholes, catch basins or water gate boxes and causing covers to be stuck in the frame.

SPECIAL PROVISION 105
CONSTRUCTION AREA

Construction Areas located in the Towns of Blue Hill, Penobscot, Orland, Dover-Foxcroft, and Sebec have been established by the Maine Department of Transportation (MDOT) in accordance with provisions of 29-A § 2382 Maine Revised Statutes Annotated (MRSA).

Project 18995.43, the sections of highway under construction in Hancock and Piscataquis Counties:

- beginning on Route 15 in Blue Hill 0.05 of a mile north of Hinckley Hill Road and extending northerly 7.99 miles to the intersection of US Route 1 and State Route 15.*
- beginning on Route 15 in Dover-Foxcroft 0.97 of a mile north of intersection of Norton Hill Road and extending northerly on Route 15 for 3.76 miles.*
- beginning on Route 6 in Dover-Foxcroft 0.15 of a mile northeast of intersection of Free Street, extending northeasterly 6.40 miles, ending at 0.30 of a mile west of intersection of Milo Road, Village Road, and Stagecoach Road.*

Per 29-A § 2382 (7) MRSA, the MDOT may “issue permits for stated periods of time for loads and equipment employed on public way construction projects, United States Government projects or construction of private ways, when within construction areas established by the Department of Transportation. The permit:

- A. Must be procured from the municipal officers for a construction area within that municipality;*
- B. May require the contractor to be responsible for damage to ways used in the construction areas and may provide for:
 - (1) Withholding by the agency contracting the work of final payment under contract; or*
 - (2) The furnishing of a bond by the contractor to guarantee suitable repair or payment of damages.**
- The suitability of repairs or the amount of damage is to be determined by the Department of Transportation on state-maintained ways and bridges, otherwise by the municipal officers;*
- C. May be granted by the Department of Transportation or by the state engineer in charge of the construction contract; and*
- D. For construction areas, carries no fee and does not come within the scope of this section.”*

The Municipal Officers for the Towns of Blue Hill, Penobscot, Orland, Dover-Foxcroft, and Sebec agreed that an Overlimit Permit will be issued to the Contractor for the purpose of using loads and equipment on municipal ways in excess of the limits as specified in 29-A MRSA, on the municipal ways as described in the “Construction Area.”

As noted above, a bond may be required by the municipality, the exact amount of said bond to be determined prior to use of any municipal way. The MDOT will assist in determining the bond amount if requested by the municipality.

The maximum speed limits for trucks on any town way will be 25 mph (40 km per hour) unless a higher legal limit is specifically agreed upon in writing by the Municipal Officers concerned.

State of Maine
 Department of Labor
 Bureau of Labor Standards
 Augusta, Maine 04333-0045
 Telephone (207) 623-7906

Wage Determination - In accordance with 26 MRS §1301 et. seq., this is a determination by the Bureau of Labor Standards, of the fair minimum wage rate to be paid to laborers and workers employed on the below titled project.

**2020 Fair Minimum Wage Rates
 Highway & Earth Statewide**

<u>Occupation Title</u>	<u>Minimum</u>	<u>Minimum</u>	<u>Total</u>	<u>Occupation Title</u>	<u>Minimum</u>	<u>Minimum</u>	<u>Total</u>
	<u>Wage</u>	<u>Benefit</u>			<u>Wage</u>	<u>Benefit</u>	
Asphalt Raker	\$16.00	\$0.00	\$16.00	Laborers (Helpers & Tenders)	\$15.59	\$0.56	\$16.15
Backhoe Loader Operator	\$20.00	\$2.60	\$22.60	Laborer - Skilled	\$18.00	\$1.20	\$19.20
Boom Truck (Truck Crane) Operator	\$25.00	\$4.94	\$29.94	Loader Operator - Front-End	\$19.47	\$3.00	\$22.47
Bulldozer Operator	\$21.50	\$4.52	\$26.02	Mechanic- Maintenance	\$22.00	\$3.09	\$25.09
Carpenter	\$22.46	\$2.19	\$24.65	Millwright	\$29.82	\$7.73	\$37.55
Cement Mason/Finisher	\$16.00	\$4.04	\$20.04	Painter	\$18.00	\$0.45	\$18.45
Crane Operator =>15 Tons)	\$30.00	\$7.76	\$37.76	Paver Operator	\$20.50	\$0.44	\$20.94
Crusher Plant Operator	\$20.50	\$5.33	\$25.83	Pipelayer	\$23.78	\$1.60	\$25.38
Driller - Rock	\$12.00	\$8.82	\$20.82	Plumber (Licensed)	\$26.00	\$4.50	\$30.50
Electrician - Licensed	\$28.00	\$6.27	\$34.27	Reclaimer Operator	\$22.91	\$13.25	\$36.16
Electrician Helper/Cable Puller	\$18.00	\$1.84	\$19.84	Roller Operator - Earth	\$16.00	\$0.24	\$16.24
Elevator Constructor/Installer	\$20.00	\$1.78	\$21.78	Roller Operator - Pavement	\$19.50	\$3.70	\$23.20
Excavator Operator	\$21.50	\$3.08	\$24.58	Screed/Wheelman	\$18.43	\$1.24	\$19.67
Fence Setter	\$18.00	\$1.30	\$19.30	Stone Mason	\$20.00	\$0.42	\$20.42
Flagger	\$13.00	\$0.00	\$13.00	Truck Driver - Light	\$16.00	\$0.44	\$16.44
Grader/Scraper Operator	\$20.00	\$0.65	\$20.65	Truck Driver - Medium	\$19.00	\$1.97	\$20.97
Highway Worker/Guardrail Installer	\$18.25	\$1.66	\$19.91	Truck Driver - Heavy	\$17.19	\$0.85	\$18.04
Hot Top Plant Operator	\$22.91	\$13.25	\$36.16	Truck Driver - Tractor Trailer	\$17.00	\$0.00	\$17.00
Ironworker - Reinforcing	\$29.23	\$7.18	\$36.41	Truck Driver - Mixer (Cement)	\$17.25	\$2.26	\$19.51
Ironworker - Structural	\$26.01	\$22.27	\$48.28				

The Laborer classifications include a wide range of work duties. Therefore, if any specific occupation to be employed on this project is not listed in this determination, call the Bureau of Labor Standards at the above number for further clarification.

Welders are classified in the trade to which the welding is incidental.

Apprentices – The minimum wage rate for registered apprentices are those set forth in the standards and policies of the Maine State Apprenticeship and Training Council for approved apprenticeship programs.

Title 26 §1310 requires that a clearly legible statement of all fair minimum wage and benefits rates to be paid the several classes of laborers, workers and mechanics employed on the construction on the public work must be kept posted in a prominent and easily accessible place at the site by each contractor and subcontractor subject to sections 1304 to 1313.

Appeal – Any person affected by the determination of these rates may appeal to the Commissioner of Labor by filing a written notice with the Commissioner stating the specific grounds of the objection within ten (10) days from the filing of these rates.

A true copy

Attest: Scott R. Cotnoir
 Scott R. Cotnoir
 Wage & Hour Director
 Bureau of Labor Standards

Expiration Date: 12-31-2020

SPECIAL PROVISION
SECTION 105
GENERAL SCOPE OF WORK
(LIMITATIONS OF OPERATIONS)

1. A 48-hour notice will be required for any changes in the work schedule.
2. Crack sealing the locations will be completed in the order of priority and each location shall be completed in its entirety prior to mobilizing to the next location

SPECIAL PROVISION
SECTION 107
PROSECUTION AND PROGRESS
(Contract Time – Working Days)

This Contract shall be completed within **(15)** working days. The Contractor may begin work anytime on or after **June 1st 2020** in accordance with Standard Specification 104.4.2 and upon approval of all required submittals. Time charge will commence on the start date or no later than **September 3rd 2020** whichever occurs first.

At least 21 calendar days prior to the desired Begin Construction Date **and no later than June 15th**, the Contractor shall submit an **electronic copy of their signed request to begin work and the Begin Construction Date**. This signed request shall be sent read receipt through **email** with their **Schedule of Work**, in accordance with Standard Specification 107.4.2, to **Shawn.Smith@Maine.gov**, **Dale.Mayo@Maine.gov**, **Scott.Bickford@Maine.gov** and the **Jeremy.S.Parker@Maine.gov**. The Contractor shall notify all utility contacts listed in the 104 Special Provision and provide the utility contacts the submitted schedule of work within 2 calendar days of the schedule of work submittal. **A penalty in the amount of \$500/day will be assessed for each calendar day or partial calendar day beyond June 15th that the schedule of work is not received.** Upon receipt of the schedule of work, a pre-construction meeting will be scheduled.

The Contractor may request to adjust the submitted schedule of work and Begin Construction Date once after the initial submittal. The Department will allow adjustments in the Begin Construction Date of up to **seven calendar days** if the request is made at least **21 calendar days** prior to the updated Begin Construction Date. This signed request shall be sent read receipt through **email** with their **Schedule of Work**, in accordance with Standard Specification 107.4.2, to **Shawn.Smith@Maine.gov**, **Dale.Mayo@Maine.gov**, and **Scott.Bickford@Maine.gov**. The Contractor shall notify all utility contacts listed in the 104 Special Provision and provide the utility contacts the updated schedule of work within 2 calendar days of the request to adjust the Begin Construction Date.

SPECIAL PROVISION
SECTION 107
TIME
(Liquidated Damages)
(Working Days)

107.7.2 SCHEDULE OF LIQUIDATED DAMAGES

Revise this section by removing the numbers in the chart and replace with the following:

Original Contract Amount

From More Than	to	To and Including	Amount of Liquidated Damages per Working Day
\$ 0	to	\$ 100,000.00	\$400.00
\$ 100,000.00	to	\$ 250,000.00	\$800.00
\$ 250,000.00	to	\$ 500,000.00	\$1,000.00
\$ 500,000.00	to	\$1,000,000.00	\$1,250.00
\$1,000,000.00	to	\$2,000,000.00	\$1,600.00
\$2,000,000.00	to	\$4,000,000.00	\$2,000.00
\$4,000,000.00	and	More	\$3,350.00

SPECIAL PROVISION
SECTION 424
ASPHALT RUBBER CRACK SEALER - Type 4

Description This work shall consist of furnishing all labor, equipment and materials necessary to clean, fill and seal longitudinal and transverse cracks in bituminous concrete pavement courses. Materials are to be thoroughly applied to seal the cracks. This work shall consist of the furnishing and placement of crack sealing material in the cracks of existing bituminous concrete pavement in accordance with these Special Provisions. This work shall consist of crack cleaning and drying, material supply and heating, preparation and application material, material finishing or shaping, and providing and installing barrier material or curing materials as required.

Materials Asphalt Rubber Crack Sealer shall be an asphalt and rubber compound designed for a temperature range of 64-28 °C, and which improves the strength and performance of the base asphalt cement. Hot pour rubber crack sealant material shall conform to ASTM D-6690, Type 4.

Cone Penetration	90 - 150
Flow @ 60°C [140°F]	< 1/8 inch]
Bond, non-immersed	Three ½ inch specimens pass 3 cycles @ 200% extension @ -29°C [-20°F]
Resilience, %	60 min
Asphalt Compatibility, ASTM D5329	pass*

* There shall be no failure in adhesion, formation of any oily exudate at the interface between the sealant and asphaltic concrete or other deleterious effects on the asphaltic concrete or sealant when tested at 140°F.

The contractor shall provide the Resident or authorized representative with a copy of the material manufacturer's recommendations pertaining to heating, application, and reheating prior to the beginning of operations or the changing of materials

CONSTRUCTION REQUIREMENTS

Weather Asphalt Rubber Crack Sealer shall not be applied on a wet surface, or when the atmospheric temperature is below 50°F in a shaded area at the job site, or when weather conditions are otherwise unfavorable to proper construction procedures.

Equipment Equipment used in the performance of the work shall be subject to the Resident's or authorized representative's approval and shall be maintained in a satisfactory working condition at all times. As a minimum, the equipment required will consist of the following:

(1) Air Compressor and air wand: A portable air compressor shall be supplied to clean the cracks to be sealed prior to using a hot air lance. The air compressor shall be coupled with hose and air wand and be capable of furnishing not less than 150 CFM of air at not less than 100 psi pressure through a 5/8"-inch diameter nozzle. A 1/2 -inch or 3/4-inch nozzle may be used with approval of the Inspector as long as the pressure requirements are being met. The compressor shall be equipped with traps that will maintain the compressed air free of oil and water.

(2) Sweeper: Manually operated, gas powered air-broom or self-propelled sweeper designed especially for use in cleaning pavements shall be used to remove debris, dirt, and dust from the cracks.

(3) Hot Air Lance: The hot air lance shall be independent of the air wand unit. The hot air lance shall be operated with propane and compressed air in combination and provide 1000 ft/sec of heated air at 2000°F - 3000°F. The lance should draw propane from no smaller than a 100 lb tank using separate hoses for propane and air draw. The hoses shall be wrapped together with reflectorized wrap to keep them together and to protect workers in low light situations.

(4) Hand Tools: Shall consist of V-shaped squeegee, brooms, shovels, metal bars with chisel shaped ends, and any other tools which may be satisfactorily used to accomplish this work.

(5) Melting Kettle: The unit used to melt the joint sealing compound shall be a double boiler, indirect fired type. The space between inner and outer shells shall be filled with a suitable heat transfer oil or substitute having a flash point of not less than 608°F. The kettle shall be equipped with a satisfactory means of agitating and mixing the joint sealer at all times. This may be accomplished by continuous stirring with mechanically operated paddles and/or a continuous circulating gear pump attached to the heating unit. The kettle must be equipped with thermostatic control calibrated between 200°F and 550°F. The Contractor shall either provide a jacketed thermometer that accurately displays the sealant temperature within the kettle, or provide the Resident or authorized representative with a suitable device for verifying the sealant temperature in the kettle. Temperatures must be able to be checked at any time during the heating of material, application of material, or at the end of the application operation.

Preparations of Cracks All cracks shall be blown free of loose material, dirt, vegetation, and other debris by high pressure air prior to the used of the hot air lance. Material removed from the crack shall be removed from the pavement surface by means of compressed air, power sweeper or appropriate hand tools as required. Cracks showing evidence of vegetation after being blown out shall be additionally cleaned by appropriate hand tools and additionally blown out. All cracks must be blown and heated via the hot air lance no more than 5 minutes prior to the crack being sealed. Distance between the hot air lance and the crack sealing unit should be no more than 50 ft to eliminate reinvasion of water, debris, and other incompressible materials. All

debris, vegetation, and water shall be removed to enhance adhesion of the crack sealing material. THIS WORK SHALL NOT BE DONE IN INCLEMENT WEATHER.

Preparation and Placement of Sealer The rubber crack sealer material shall be heated and applied at the temperature specified by the manufacturer and approved by the Resident or authorized representative. Any material that has been heated above the manufacturer's specification shall not be used. Material that is reheated or held at temperature for an extended period of time may be used as allowed by the manufacturer's specification and approval of the Resident or authorized representative. A copy of the manufacturer's specification shall be provided to the Project when requested.

The Contractor shall provide the Resident or authorized representative with a suitable device for verifying the sealant temperature in the kettle and at the application site.

Any loose material on the surface or in the crack, which may contaminate the crack sealer or impede bonding of the sealant to the pavement, is to be removed by hand tools prior to crack filling. No crack filling material shall be applied in a crack that is wet or where frost, snow, or ice is present. The ambient air temperature must be 50 or higher.

Any over application or spills are to be removed to the satisfaction of the Resident or authorized representative. Any sealed areas with damaged or contaminated sealer or visible voids are to be removed, prepared and resealed. Defective or leaking valves and wands will be repaired or replaced before work continues. If repairs or replacement of defective equipment cannot be accomplished immediately then the Department may permit work to continue but deduct any excess quantities placed as it determines.

Sealer shall be delivered to the crack while the cracks are still hot from the hot air lance preparation through a pressure hose line and applicator nozzle or shoe.

If the work scope requires a flush fill with minimal overbanding then a nozzle sized to fill the cracks shall be used.

If the work scope required crack filling and sealing with overband, then a shoe sized to meet the overband width shall be used. Generally, the shoe width and the sealer overbanding area shall range from 1 inch – 1.5 inch. Overbanding width may vary from the range specified depending on the width and severity of the cracks.

The applicator shall be followed by a V-shaped squeegee to minimize the thickness of the overband. The sealer shall be applied at a rate that produces a coating thickness of 1/8 - inch, typical.

If the sealed area is to be opened to traffic immediately, a barrier material (de-tackifier) such as Glenzoil or an equivalent product approved by the Resident shall be provided by the Contractor and shall be applied to the crack sealer to prevent pickup as directed by the Resident or authorized representative.

If the sealed areas are to be paved over with a hot mix treatment then a 48 hour minimum cure time and use of barrier material (de-tackifier) will be required. Cure times may be extended if excessive pick-up of the crack sealants occurs.

Quality of Work Any excess of sealer, spilled or overapplied, shall be removed from the pavement by approved methods and discarded. Any quality of work determined to be below normal acceptable standards will not be accepted, and will be corrected and/or replaced as directed by the Resident or authorized representative.

Method of Measurement Asphalt Rubber Crack Sealer will be measured by the pound of sealant used. The manufacturer's weights of the sealant for each block (pill) will be accepted as a basis for measurement.

Should tank checks be required to verify material usage, or calculate initial or final gallons remaining in the kettle, a calibrated tank gauge or tank stick shall be used to measure the tank gallons, and a volume correction shall be calculated using Table:1 to correct the gallons to 60 ° F. The corrected gallons shall then be multiplied by the pounds per gallon at 60 ° F listed in the product data sheet provided for the crack seal product being used. The corrected volume and resultant pounds shall be made part of the method of measurement, with consideration given to blocks (pills) added during the day and applied in an acceptable manner.

Basis of Payment The accepted quantity of Asphalt Rubber Crack Sealer will be paid for at the contract unit price per pound complete in place. This price shall be full compensation for furnishing and placing crack sealer, including cleaning cracks and furnishing and placing barrier materials if necessary.

Payment will be made under:

<u>Pay Item</u>	<u>Pay Unit</u>
424.24 Asphalt Rubber Crack Sealer Type 4, Applied	Pound

Conversion Table:1

t	M	t	M	t	M	t	M	t	M	t	M
100	0.9861	135	0.9740	170	0.9621	205	0.9503	240	0.9385	275	0.9269
101	0.9857	136	0.9737	171	0.9618	206	0.9499	241	0.9382	276	0.9266
102	0.9854	137	0.9734	172	0.9614	207	0.9496	242	0.9379	277	0.9263
103	0.9851	138	0.9730	173	0.9611	208	0.9493	243	0.9375	278	0.9259
104	0.9847	139	0.9727	174	0.9607	209	0.9489	244	0.9372	279	0.9256
105	0.9844	140	0.9723	175	0.9604	210	0.9486	245	0.9369	280	0.9253
106	0.9840	141	0.9720	176	0.9601	211	0.9483	246	0.9365	281	0.9250
107	0.9837	142	0.9716	177	0.9597	212	0.9479	247	0.9362	282	0.9246
108	0.9833	143	0.9713	178	0.9594	213	0.9476	248	0.9359	283	0.9243
109	0.9830	144	0.9710	179	0.9590	214	0.9472	249	0.9356	284	0.9240
110	0.9826	145	0.9706	180	0.9587	215	0.9469	250	0.9352	285	0.9236
111	0.9823	146	0.9703	181	0.9584	216	0.9466	251	0.9349	286	0.9233
112	0.9819	147	0.9699	182	0.9580	217	0.9462	252	0.9346	287	0.9230
113	0.9816	148	0.9696	183	0.9577	218	0.9459	253	0.9342	288	0.9227
114	0.9813	149	0.9693	184	0.9574	219	0.9456	254	0.9339	289	0.9223
115	0.9809	150	0.9689	185	0.9570	220	0.9452	255	0.9336	290	0.9220
116	0.9806	151	0.9686	186	0.9567	221	0.9449	256	0.9332	291	0.9217
117	0.9802	152	0.9682	187	0.9563	222	0.9446	257	0.9329	292	0.9213
118	0.9799	153	0.9679	188	0.9560	223	0.9442	258	0.9326	293	0.9210
119	0.9795	154	0.9675	189	0.9557	224	0.9439	259	0.9322	294	0.9207
120	0.9792	155	0.9672	190	0.9553	225	0.9436	260	0.9319	295	0.9204
121	0.9788	156	0.9669	191	0.9550	226	0.9432	261	0.9316	296	0.9200
122	0.9785	157	0.9665	192	0.9547	227	0.9429	262	0.9312	297	0.9197
123	0.9782	158	0.9662	193	0.9543	228	0.9426	263	0.9309	298	0.9194
124	0.9778	159	0.9658	194	0.9540	229	0.9422	264	0.9306	299	0.9190
125	0.9775	160	0.9655	195	0.9536	230	0.9419	265	0.9302	300	0.9187
126	0.9771	161	0.9652	196	0.9533	231	0.9416	266	0.9299	301	0.9184
127	0.9768	162	0.9648	197	0.9530	232	0.9412	267	0.9296	302	0.9181
128	0.9764	163	0.9645	198	0.9526	233	0.9409	268	0.9293	303	0.9177
129	0.9761	164	0.9641	199	0.9523	234	0.9405	269	0.9289	304	0.9174
130	0.9758	165	0.9638	200	0.9520	235	0.9402	270	0.9286	305	0.9171
131	0.9754	166	0.9635	201	0.9516	236	0.9399	271	0.9283	306	0.9167
132	0.9751	167	0.9631	202	0.9513	237	0.9395	272	0.9279	307	0.9164
133	0.9747	168	0.9628	203	0.9509	238	0.9392	273	0.9276	308	0.9161
134	0.9744	169	0.9624	204	0.9505	239	0.9389	274	0.9273	309	0.9158

Legend: t = observed temperature in degrees Fahrenheit.
M = multiplier for reducing volumes to the basis of 60° F.

Conversion Table:1

t	M	t	M	t	M	t	M	t	M
310	0.9154	350	0.9024	390	0.8896	430	0.8768	470	0.8643
311	0.9151	351	0.9021	391	0.8892	431	0.8765	471	0.8640
312	0.9148	352	0.9018	392	0.8889	432	0.8762	472	0.8636
313	0.9145	353	0.9015	393	0.8886	433	0.8759	473	0.8633
314	0.9141	354	0.9011	394	0.8883	434	0.8756	474	0.8630
315	0.9138	355	0.9008	395	0.8880	435	0.8753	475	0.8627
316	0.9135	356	0.9005	396	0.8876	436	0.8749	476	0.8624
317	0.9132	357	0.9002	397	0.8873	437	0.8746	477	0.8621
318	0.9128	358	0.8998	398	0.8870	438	0.8743	478	0.8618
319	0.9125	359	0.8995	399	0.8867	439	0.8740	479	0.8615
320	0.9122	360	0.8992	400	0.8864	440	0.8737	480	0.8611
321	0.9118	361	0.8989	401	0.8861	441	0.8734	481	0.8608
322	0.9115	362	0.8986	402	0.8857	442	0.8731	482	0.8605
323	0.9112	363	0.8982	403	0.8854	443	0.8727	483	0.8602
324	0.9109	364	0.8979	404	0.8851	444	0.8724	484	0.8599
325	0.9105	365	0.8976	405	0.8848	445	0.8721	485	0.8596
326	0.9102	366	0.8973	406	0.8845	446	0.8718	486	0.8593
327	0.9099	367	0.8969	407	0.8841	447	0.8715	487	0.8590
328	0.9096	368	0.8966	408	0.8838	448	0.8712	488	0.8587
329	0.9092	369	0.8963	409	0.8835	449	0.8709	489	0.8583
330	0.9089	370	0.8960	410	0.8832	450	0.8705	490	0.8580
331	0.9086	371	0.8957	411	0.8829	451	0.8702	491	0.8577
332	0.9083	372	0.8953	412	0.8826	452	0.8699	492	0.8574
333	0.9079	373	0.8950	413	0.8822	453	0.8696	493	0.8571
334	0.9076	374	0.8947	414	0.8819	454	0.8693	494	0.8568
335	0.9073	375	0.8944	415	0.8816	455	0.8690	495	0.8565
336	0.9070	376	0.8941	416	0.8813	456	0.8687	496	0.8562
337	0.9066	377	0.8937	417	0.8810	457	0.8683	497	0.8559
338	0.9063	378	0.8934	418	0.8806	458	0.8680	498	0.8556
339	0.9060	379	0.8931	419	0.8803	459	0.8677	499	0.8552
340	0.9057	380	0.8928	420	0.8800	460	0.8674		
341	0.9053	381	0.8924	421	0.8797	461	0.8671		
342	0.9050	382	0.8921	422	0.8794	462	0.8668		
343	0.9047	383	0.8918	423	0.8791	463	0.8665		
344	0.9044	384	0.8915	424	0.8989	464	0.8661		
345	0.9040	385	0.8912	425	0.8984	465	0.8658		
346	0.9037	386	0.8908	426	0.8781	466	0.8655		
347	0.9034	387	0.8905	427	0.8778	467	0.8652		
348	0.9031	388	0.8902	428	0.8775	468	0.8649		
349	0.9028	389	0.8899	429	0.8772	469	0.8646		

Legend: t = observed temperature in degrees Fahrenheit.
M = multiplier for reducing volumes to the basis of 60° F.

SPECIAL PROVISION
SECTION 424
CRACK REPAIR with HOT POUR MASTIC

Description. This work shall consist of preparing and repairing areas identified for crack repair in existing bituminous or concrete pavement layers using hot pour mastic. The hot pour mastic shall be supplied in solid form in boxes containing pre-measured binder blended with aggregates. Products to be used will be subject to approval by the Department. Repair areas will be free of sand, vegetation, water, and any previously placed rubber crack seal or crack repair materials, including cold patch. Preparation, such as cleaning and drying of the cracks by use of oil free compressed air and hot air lance shall be considered included the price per pound of crack repair mastic. Routing or any pavement removal required will be paid for under the appropriate item as described in this Special Provision.

MATERIALS

The hot pour mastic materials are hot-applied, pourable, self-adhesive mastics blended with aggregates designed for maintenance and repair of asphalt and Portland cement concrete pavements. The hot pour mastic materials are composed of highly modified polymer asphalt binder and fine graded lightweight aggregate, or standard weight aggregates as required by the application.

The mastic materials shall be delivered in the manufacturer’s original container. The material shall be pre-packaged with the manufacturers name and product name marked on each container. The materials shall conform to the following requirements:

Parameter

Color	Black
Pourability @ 400F (PTM1)*	1000-1400 gm
Stability @ 158F (PTM2)	.6in. max
Flexibility @ Low Temperature (PTM3)	Pass @ -20F
Adhesion @77F (PTM4)	15psi min.
Specific Gravity (ASTM D792)	1.35max.
Skid Resistance, BPN (ASTM E303)	40 min.
Minimum Application Temperature	375°F
Maximum Application Temperature	410°F

The density of the mastic with fine lightweight aggregate is 76 pcf (+/- 3%) and weight per gallon is 10.2 lb/ gal at 60°F. (ref: PolyPatch or equivalent)

The density of the mastic with standard weight aggregate is 116 pcf (+/- 3%) and the weight per gallon is 15.5 lbs/gal at 60°F. (ref: MasticOne or equivalent)

EQUIPMENT

Equipment Equipment used in the performance of the work shall be subject to the Departments or authorized representative's approval and shall be maintained in a satisfactory working condition at all times.

(a) Air Compressor: Air compressors shall be portable and capable of furnishing not less than 4 yd³ of air per minute at not less than 90 psi pressure at the nozzle. The compressor shall be equipped with traps that will maintain the compressed air free of oil and water.

(b) Sweeper: Manually operated, gas powered air-broom or self-propelled sweeper designed especially for use in cleaning pavements shall be used to remove debris, dirt, and dust from the cracks.

(c) Hot Air Lance: Should operate with propane and compressed air in combination at 2000°F - 3000°F, exit air heated at 1000 ft/s. The lance should draw propane from no smaller than a 100 lb tank using separate hoses for propane and air draw. The hoses shall be wrapped together with reflectorized wrap to keep them together and to protect workers in low light situations.

(d) Hand Tools: Shall consist of Boxed or V-shaped squeegee, brooms, shovels, metal bars with chisel shaped ends, and any other tools which may be satisfactorily used to accomplish this work.

(e) Melting Kettle:) The unit used to heat the mastics shall be a double boiler unit equipped with continuous horizontal full sweep agitation and have separate thermostatic control devices that will automatically regulate hot oil and material temperature. Separate digital readouts shall display the temperatures of the hot oil and material. The kettle shall be equipped with mixing paddles, blending augers, or other satisfactory means of agitating, mixing, and blending the aggregates and mastic together. The kettle must be equipped with thermostatic control calibrated between 200°F and 550°F.

If required in the contract the router or crack saw equipment for preparing cracks shall be of a rotary impact type cutter, equipped with a carbide bit or a diamond-blade crack saw which will provide a reservoir of specified dimensions.

An application wand may be required for the work type, and shall apply a controlled flow of material via an insulated or heated hose. The nozzle shall distribute the material as called for in this specification. A pressure regulator shall be provided to regulate pressure at the nozzle. A bypass line into the holding tank is required for use when the nozzle is shut off.

CONSTRUCTION REQUIREMENTS

Weather Hot Pour Mastics shall not be applied on a wet or damp surface, or when the atmospheric temperature is below 45°F in a shaded area at the job site, or when weather conditions are otherwise unfavorable to proper crack repair procedures.

Preparation All cracks shall be prepared to receive the mastic material. All cracks must be cleaned of debris, dried and heated to ensure optimal bonding of the sealant material to the existing pavement and crack edges. All cracks shall be flush filled with pre-blended mastic with minimal overband in the same workday as directed by the Resident or authorized representative.

Cracks of less than 1 inch in width shall be shaped as directed by using a crack router or crack saw to a minimum 1 inch width and depth. The router or saw shall be guided so that the crack lies entirely within the routed channel. All material routed or sawn from the cracks shall immediately be removed from the crack and surrounding paved area by use of compressed air, sweeping, or combination of both.

Cracks greater than 1 inch in width shall be thoroughly cleaned by use of compressed air and dried by use of a hot air lance. Any loose or broken materials will be removed from the repair area before placing mastic materials. If it is determined that additional pavement removal or preparation is needed by means of milling, sawing, or cutting of existing pavement the work will be paid under an appropriate pay item. All materials routed, sawn, cut, or otherwise removed from the areas to be repaired shall immediately be removed from the crack and surrounding paved area by use of compressed air sweeping, or combination of both.

Cracks 1 inch in width to 3 inch in width shall be filled with mastic pre-blended with fine lightweight aggregate.

Cracks 3 inch in width to 6 inch width, or repairs that are more structural in nature, such as potholes, depressions, fills or repairs around utility adjustments shall be filled with mastic pre-blended with standard weight aggregates. Generally repairs wider than 6 inches, or that extend below the surface layer may require additional pavement removal or other preparation.

All mastic materials shall be heated to between 380°F and 410°F and thoroughly agitated prior to application. A non-contact infrared thermometer shall be used periodically to monitor the temperature of the material as it exits the kettle. Material may not be used if it is heated beyond the safe heating temperature of 410°F, exceeds the recommended pot life, or is reheated more than one time.

The mastics may be applied to large repair areas when the material has been heated to the lower end of the temperature range to minimize material flow and cooling time.

Mastics shall be applied to the repair areas directly from the melting kettle chute, wand or other conveyance method filled from the kettle. If bucketed, material cooling during transfer must be minimized.

The repair area shall be filled flush to the pavement surface. The material shall be poured into the repair area and worked using boxed or v-shaped squeegees, tools, lutes or heated irons. Care should be taken not to over work the material and cause unequal dispersion of the aggregate within the repair. The material may be applied in multiple lifts to accommodate material shrinkage or flow during cooling.

After the material has been applied to the repair, indirect heating by torch or hot air lance can be used to heat the edges and ensure a watertight seal. Do not burn, scorch or ignite the mastic or adjoining pavement when heating.

Do not allow traffic on the repaired areas for ½ hour, or until the material has cooled enough to support traffic and tracking is minimal.

Quality of Work Excess mastic shall be removed from the pavement by approved methods and discarded. Any work determined to be below normal acceptable standards will not be accepted, and will be corrected and/or replaced as directed by the Resident or authorized representative.

Basis of Payment The accepted quantity of Crack Repair with Hot Pour Mastic will be paid for at the contract unit price per pound. This price will be full compensation for furnishing the appropriate material type for the repair being done, heating, placing and finishing the mastic materials, as well as cleaning and preparing the areas for installation of the mastic, including the use of compressed air, hot air lance, and any sweeping required to remove contaminates from and dry the areas to be treated. Areas identified as requiring pavement removal by means of cutting, sawing, grinding, or routing will be paid under an appropriate contract item.

Payment will be made under:

<u>Pay Item</u>	<u>Pay Unit</u>
424.38 Crack Repair, Hot Pour Mastic	Pound
424.42 Crack Routing	Linear Foot

**SPECIAL PROVISION
SECTION 652
MAINTENANCE OF TRAFFIC**

Work Area At the work site, signs and channelizing devices shall be used as referenced in the following 2 pages and as directed by the Resident. Signs include:

Road Work Next 2 Mi.
One Lane Road Ahead
Flagger Sign (Flagger Symbol)

The Contractor shall conduct their operations in such a manner that the roadway will only be restricted to one lane for a distance needed to safely perform the work with a maximum restriction to one lane of 800 m [2,500 ft].

Additional flaggers shall be used at intersections and side roads as needed when the traffic from these areas can not be safely and effectively directed by the permanent mainline flaggers in use.

Cones may be used along the centerline of the work zone for safety at the contractors or MDOT's discretion for safety.

All signs shall use super high intensity fluorescent retroreflective sheeting, ASTM 4956 - Type VII.

652.16 Basis of Payment: The furnishing, installation and maintenance of all Traffic Control Devices, including cones, will not be paid for directly, but will be incidental to the 424 item(s).

The furnishing of the necessary quantity of flaggers, including hiring, transporting, equipping, supervising and the payment of flaggers, breaker flaggers and all overhead and incidentals necessary to complete the work will not be paid for directly, but will be incidental to the 424 item(s).

MOBILE OPERATION ON A TWO LANE, TWO WAY ROAD USING FLAGGERS.

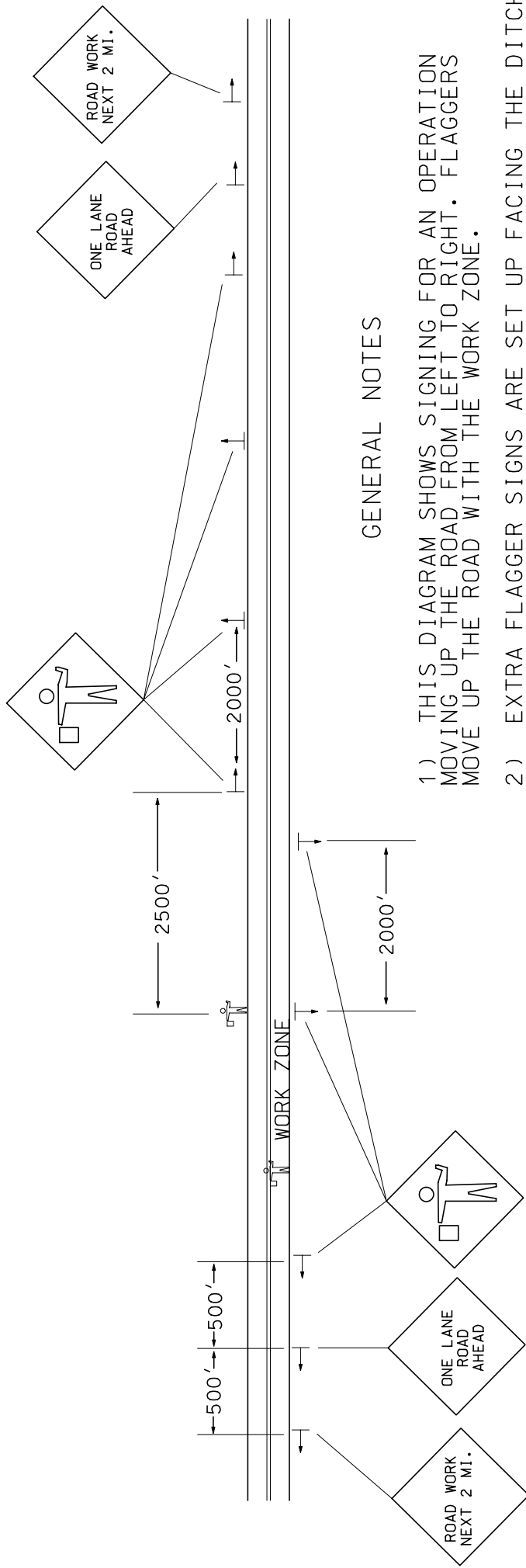

GENERAL NOTES

- 1) THIS DIAGRAM SHOWS SIGNING FOR AN OPERATION MOVING UP THE ROAD FROM LEFT TO RIGHT. FLAGGERS MOVE UP THE ROAD WITH THE WORK ZONE.
- 2) EXTRA FLAGGER SIGNS ARE SET UP FACING THE DITCH 2000 FT. APART SO THAT THEY CAN BE TURNED TO FACE ONCOMING TRAFFIC AS THE FLAGGER PASSES. THE FLAGGER SIGN UPSTREAM SHALL NOT BE REMOVED UNTIL THE FLAGGER IS 500 FT. PAST THE DOWNSTREAM SIGN.
- 3) EACH OPERATION SHALL HAVE A PERSON WHOSE RESPONSIBILITY IS TRAFFIC CONTROL INCLUDING THE PROPER SETUP AND REMOVAL OF SIGNS.
- 4) THE PERSON RESPONSIBLE FOR TRAFFIC CONTROL MAY WANT TO PERIODICALLY PLACE CONES ON THE CENTERLINE TO REINFORCE THE FACT THAT MOTORISTS ARE IN A WORK ZONE.
- 5) AT THE DISCRETION OF THE MDT REPRESENTATIVE CONES MAY BE REQUIRED ALONG THE CENTERLINE OF THE WORK ZONE FOR SAFETY.
- 6) THIS APPLICATION MAY BE USED FOR MAINTENANCE PAVING OR CRACKSEALING OPERATIONS.



4.0' X 4.0'

Letters shall be 7" in height and span 37-41" across face of sign. Minimum distance in between "ROAD WORK" and "NEXT 2 MILES" shall be 3".

SPECIAL PROVISION
SECTION 652
MAINTENANCE OF TRAFFIC

Approaches. Approach signing shall include the following signs at a minimum. Field conditions may warrant the use of additional signs as determined by the Resident.

Road Work Next X* Miles
Road Work 500 Feet (Ahead)
End Road Work

Work Areas. At each work site, signs and channelizing devices shall be used as directed by the Resident.

Signs include:

Road Work xxxx¹.
One Lane Road Ahead
Flagger Sign

Other typical signs include:

Be Prepared to Stop
Low Shoulder
Bump
Pavement Ends

The above lists of Approach signs and Work Area signs are representative of the contract requirements. Other sign legends may be required.

Unless otherwise defined in Special Provision 105/107 or submitted and approved in the Traffic Control Plan, the following shall apply:

- The Contractor shall conduct their operations in such a manner that the roadway will not be restricted to one lane for more than 2,500 feet at each work area and no more than 4,000 feet for paving and milling work areas.
- Where more than one work area restricts traffic to one lane operation, these work areas shall be separated by at least 1 mile of two-way operation.

Temporary Centerline A temporary centerline shall be placed each day on all new pavement to be used by traffic. The temporary centerline, when specified of reflectorized traffic paint, shall conform to the standard marking patterns used for permanent markings. Failure to apply a temporary centerline daily will result in a Traffic Control Violation and suspension of paving operations until temporary markers are applied to all previously placed pavement.

¹ “Road Work Ahead” to be used in short duration operations and “Road Work xx feet” to be used in stationary operations as directed by the Resident.

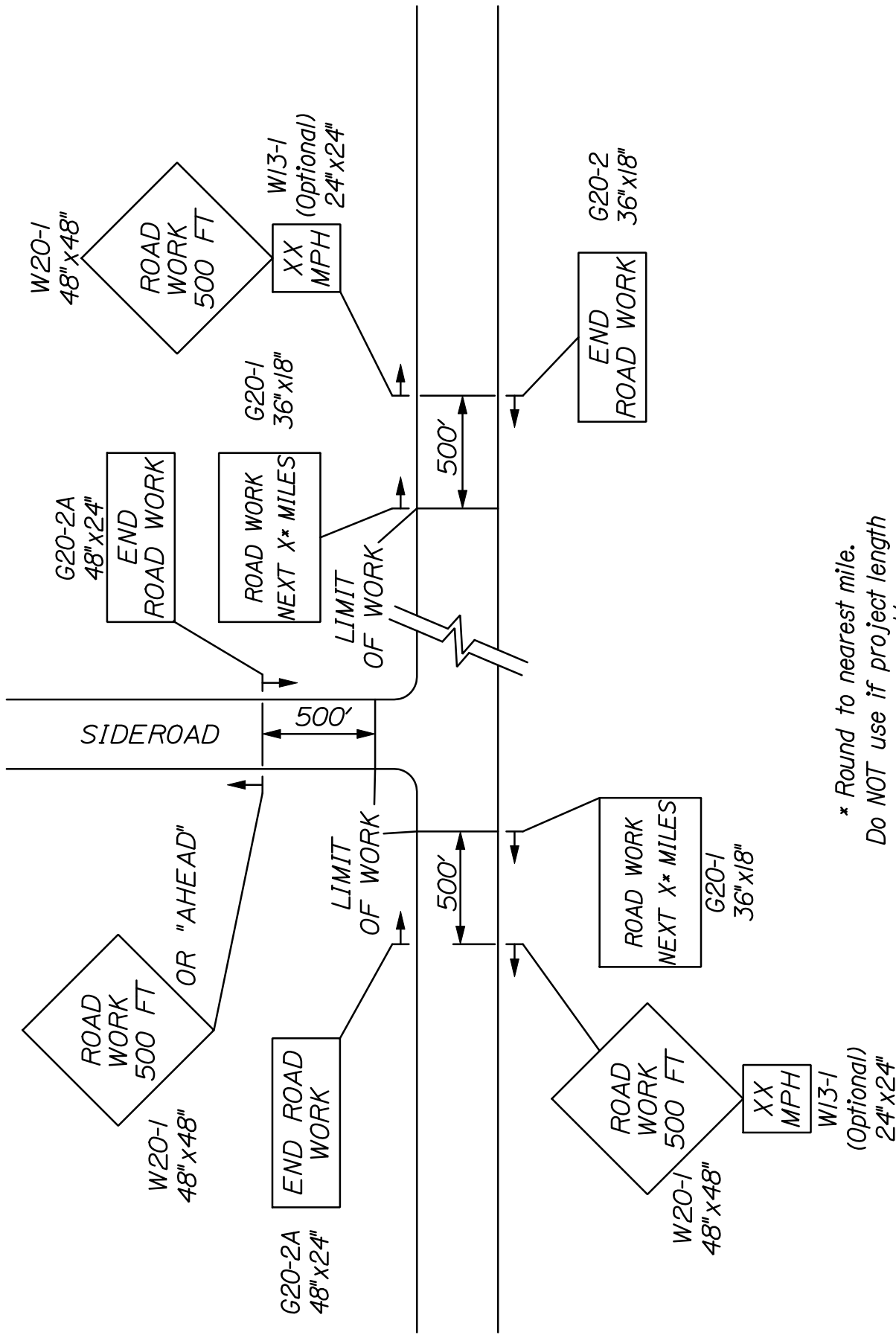

* Round to nearest mile.
 Do NOT use if project length
 is less than a 1/2 mile.

~ PROJECT APPROACH SIGNING ~
 TWO WAY TRAFFIC

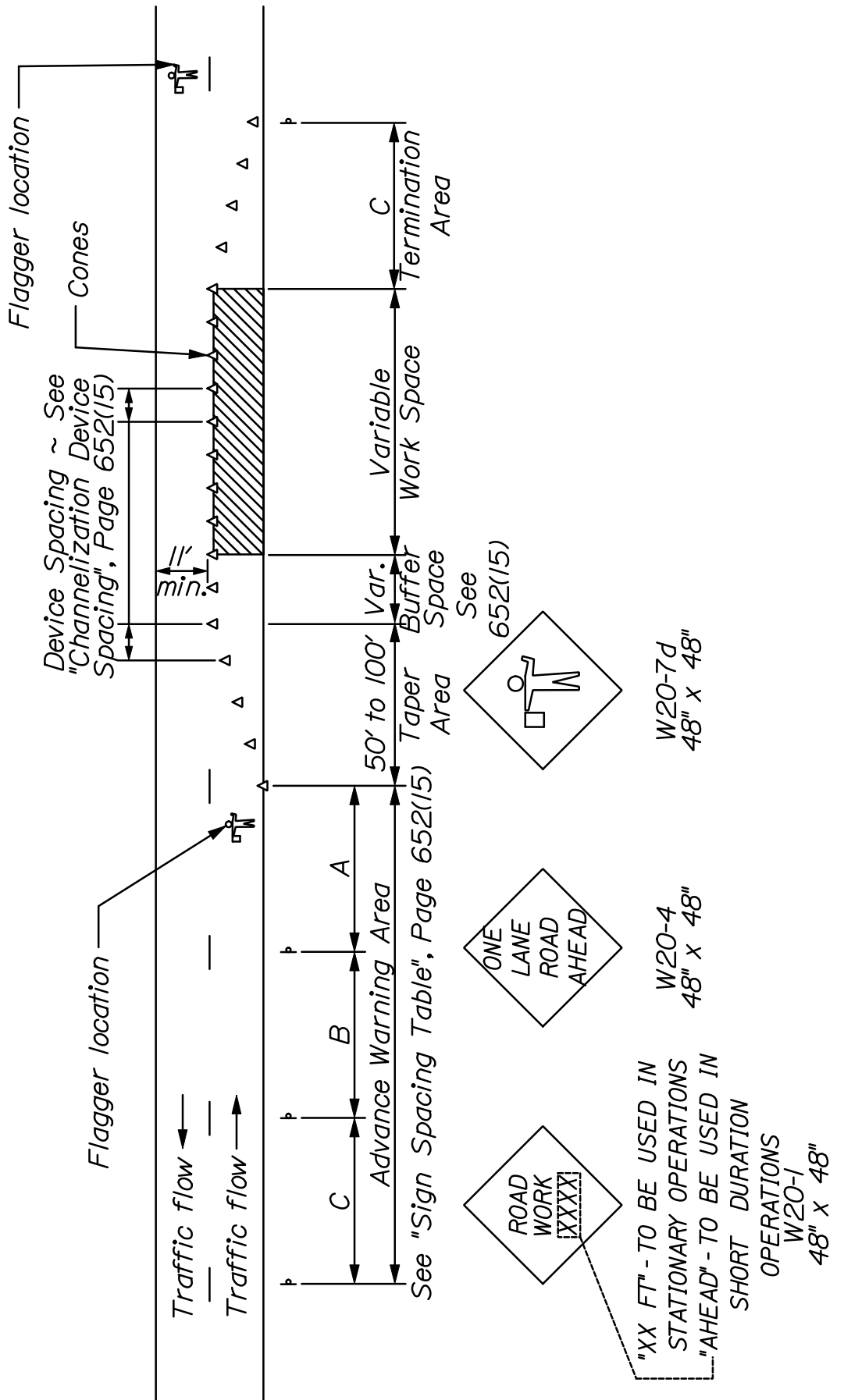

~ TYPICAL APPLICATION: TWO -WAY, TWO LANE ROADWAY, CLOSING ONE LANE USING FLAGGERS ~

* Formulas for L are as follows:
For speed limits of 40 mph or less:

$$L = \frac{WS^2}{60}$$

For speed limits of 45 mph or greater:

$$L = WS$$

* Formulas for L are as follows:

A minimum of 5 channelization devices shall be used in the taper.

TYPE OF TAPER	TAPER LENGTH (L)*
Merging Taper	at least L
Shifting Taper	at least 0.5 L
Shoulder Taper	at least 0.33 L
One-Lane, Two-Way Traffic Taper	100 ft maximum
Downstream Taper	100 ft per lane

CHANNELIZATION DEVICE SPACING

The spacing of channelization devices shall not exceed a distance in feet equal to 1.0 times the speed limit in mph when used for taper channelization, and a distance in feet of 2.0 times the speed limit in mph when used for tangent channelization.

GENERAL NOTES:

1. Final placement of signs and devices may be changed to fit field conditions as approved by the Resident.
2. Maintain same number of lanes for a shifting taper.
3. Shoulder taper allowed when a minimum of 10 feet can be open from centerline for lane.

Road Type	Distance Between Signs**		
	A	B	C
Urban 30 mph or less	100	100	100
Urban 35 mph and greater	350	350	350
Rural	500	500	500
Expressway / Urban Parkway	1000	1500	2640

**Distances are shown in feet.

SUGGESTED BUFFER ZONE LENGTHS

Speed (mph)	Length (feet)	Speed (mph)	Length (feet)
20	115	40	325
25	155	45	360
30	200	50	425
35	250	55	495

SPECIAL PROVISION SECTION 656
TEMPORARY SOIL EROSION AND WATER POLLUTION CONTROL

Amend 656.3.1 Qualification of Preparer to “The preparer of the SEWPCP must be knowledgeable and experienced with the handling, use, or storage of petroleum products or the hazardous matter/substances utilized on the project including the onsite fueling of equipment.”

The Soil Erosion and Water Pollution Control Plan (SEWPCP) will consist of the following:

Standard Specification 656.3.3 a) & b)

Standard Specification 656.3.4 a) & f) all sections

Preparation of the plan will be considered incidental to the contract

STANDARD DETAIL UPDATES

Standard Details and Standard Detail updates are available at:
<http://maine.gov/mdot/contractors/publications/standarddetail/>

<u>Detail #</u>	<u>Description</u>	<u>Revision Date</u>
501(02)	Pipe Pile Splice	3/05/2015
501(03)	H – Pile Splice	3/05/2015
502(04)	Concrete Curb	2/01/2019
504(07)	Diaphragm & Cross Frame Notes	10/13/2015
504(10)	Drip Bar Details	9/06/2017
505(01)	Shear Connectors	10/24/2016
507(13)	Steel Bridge Railing	6/03/2015
507(14)	Steel Bridge Railing	6/03/2015
507(31)	Barrier – Mounted Steel Bridge	8/06/2015
526(02)	Temporary Concrete Barrier	2/01/2015
526(02)	Temporary Concrete Barrier	2/01/2018
606(19)	Guardrail Type 3 – Single Rail Bridge Mounted	6/10/2019
606(21A)	Bridge Transition – Type “IA”	5/29/2019
609(08)	Precast Concrete Transition Curb	6/10/2019
609(9)	Concrete Slip Form Curb	5/06/2018
626(07)	Conduit Trench for Traffic Signals, Highway Signing and Lighting	5/17/2018
645(06)	H-Beam Posts Highway Signing	1/09/2018
652(06)	Construction Signs	10/24/2016
652(12)	Construction Traffic Control	10/24/2016
802(05)	Roadway Culvert End Slope Treatment	1/03/2017
801(11) – 801(26)	ADA Standard Details	6/03/2019

SUPPLEMENTAL SPECIFICATIONS
(Corrections, Additions, & Revisions to Standard Specifications - November 2014)

SECTION 101
CONTRACT INTERPRETATION

101.1 Abbreviations Revise the definition of AWP to “**American Wood Protection Association**”.

101.2 Definitions

Page 1-5 – Remove the definition of Bridge in its entirety and replace with:

“Bridge A structure that is erected over a depression or an obstruction, such as water, a highway or a railway, and has an opening measured along the centerline of the Roadway of more than 20 feet between: The faces of abutments; spring line of arches; extreme ends of openings of box culverts, pipes or pipe arches; or the extreme ends of openings for multiple box culverts, pipes or pipe arches.”

Page 1-12 – Remove the definition of Large Culvert in its entirety and replace with:

“Large Culvert Any structure not defined as a Culvert or Bridge that provides a drainage or non-drainage opening under the Roadway or Approaches to the Roadway, with an opening that is 5 feet but less than 10 feet.”

Remove the definition of Minor Span in its entirety and replace with:

“Minor Span Same definition as Bridge, except having an opening of between 10 feet and 20 feet, inclusive.”

SECTION 103
AWARD AND CONTRACTING

Amend this Section by adding the following:

“103.1a Tie Bids - In the case where two responsive bids from responsible bidders are equal monetarily, the Department shall determine the apparent low bidder by flipping a coin. The coin shall have sides clearly marked as heads and tails. The contractor whose first letter in their official company name that comes first in the alphabet shall be heads.

If there are three bids, each bidder will flip the coin and the bidder with the odd toss will be the winner. (i.e. if the results are two heads and a tails, the bidder who had tails is the winner). For a three way tie, bidders may flip their own coin or have the Contracts Engineer flip for them.

The coin flip will occur at the next bid opening by the Contracts and Specifications Engineer or a designee. The tied bidders may attend the coin flip in person or watch on the internet as they choose.”

In 103.3.2 Notice of Determination Revise this section by removing sections A – M and replacing with the following A - K:

(A) Default(s) or termination(s) on past or current Contracts.

**(B) Failure on past or current Contracts to pay or settle all bills for labor, Materials or services;
to comply with directives of the Department, to fulfill warranty obligations, or to provide Closeout Documentation.**

(C) "Below Standard" performance as determined from the Department's Contractor's Performance Rating process.

(D) Insufficient bonding capability or Inability of the Contractor to obtain or retain performance or Payment Bonds meeting MDOT requirements, or a pattern of unsupported Claims.

(E) Failure to accept an Award of a Contract made by the Department.

(F) Failure to provide information requested by the Department in a timely manner.

(G) Debarment, suspension or a denial of prequalification or 'award of contract' by any federal, State, or local governmental procurement agency or the Contractor's Agreement to refrain from Bidding as part of the settlement with any such agencies or any of the reasons contained in Section 102.02 of the "Rules Regarding Debarment of Contractors", Maine Department of Transportation Register 17-229, Chapter 102 (October 2, 1985).

(H) Failure to demonstrate ability to do work to the satisfaction and at the sole discretion of the Department.

(I) Number of personnel working directly for the Contractor with applicable knowledge and experience is significantly below industry standards.

(J) Safety Record, Environmental Record, Civil Rights or Equal Opportunity Record significantly below industry standards.

(K) Serious misconduct that the Department reasonably determines will substantially and adversely affect the cost, quality or timeliness of Work, or the safety of Workers or the public, any deceptive, evasive or fraudulent statements or omissions contained in the Application, made or omitted at any interview or hearing, or otherwise made to or omitted from the Department; or any other substantial deficiencies in experience or conduct that are clearly below industry standards and that clearly demonstrate in the sole discretion of the Department, that the Contractor is "Not Qualified".

SECTION 104

GENERAL RIGHTS AND RESPONSIBILITIES

This Section shall be amended by adding the following two sub-sections:

104.3.8.1 Electronic Payroll Submission On federally funded projects the prime contractor, all subcontractors, and lower-tier subcontractors will submit their certified payrolls electronically utilizing the Elations system. There is no charge to the contracting community for the use of this service. The submission of paper payrolls will not be allowed or accepted. Additional information can be found at <http://www.maine.gov/mdot/contractors/> under the “Bidder Info” go to “Electronic Payroll System.”

104.3.8.2 Payment Tracking On federally funded projects the prime contractor and all subcontractors and lower-tier subcontractors will track and confirm the delivery and receipt of all payments through the Elation System

104.4.10 Coordination of Road Closure / Bridge Closure / Bridge Width Restrictions

Revise the last sentence by adding a period after ‘Resident’; remove the “and” after Resident; and adding “**not covered by Pay Items**” between ‘costs’ and ‘will’. So that the last paragraph reads “**All Newspaper notices, radio announcements and any notifications will be subject to the approval of the Resident. All costs not covered by Pay Items will be considered incidental to the Contract.**”.

104.5.5 Prompt Payment of Subcontractors Add the following paragraph to this subsection:

C. Payment Tracking Federal Projects On federally funded projects, the prime contractor, subcontractors and lower-tier subcontractors will track and confirm the delivery and receipt of all payments through the Elation System. They will be responsible for entering all payments to all sub and lower tier contractors. MaineDOT will run a query monthly to ensure that contractors are complying and generate an e-mail to contractors who have not responded to confirm receipt of MaineDOT payment or contractor payment to lower tier subcontractors.

SECTION 105

GENERAL SCOPE OF WORK

105.2.5 Compliance with Health and Safety Laws Remove the second paragraph of this subsection in its entirety and replace with:

“For related provisions, see Sections 105.2.3 – Project Specific Emergency Planning, 105.3 – Traffic Control and Management and 105.4 – Maintenance of work.”

105.4.5 Special Detours Remove this subsection in its entirety and replace with:

“105.4.5 Maintenance of Existing Structures When a new Bridge or Minor Span is being installed on a new alignment and the existing structure is to remain in service, the Department will maintain the existing structure and the portions of the roadway required for maintaining traffic until such time that the new structure is opened to traffic and the existing structure is taken out of service. A similar situation exists when a new Bridge or Minor Span is being installed on the same alignment as the existing structure, requiring a temporary detour to be installed by the Contractor per Section 510, Special Detours, prior to removal of the existing structure. In this case, the Department will maintain the existing structure and the portions of the existing roadway required for maintaining traffic until such time that either the temporary detour is opened to traffic or the Contractor begins any work on the existing structure, including, but not limited to, repairs, modifications, moving, demolition or removal. In either case, once the new structure or temporary detour is opened to traffic, or the Contractor begins any work on the existing structure, the Contractor shall be solely responsible for all maintenance of the existing structure and the portions of the existing approaches that lie outside the new roadway or the temporary detour, respectively. This specification is not intended to supersede Standard Specification Section 104.3.11, Responsibility for Property of Others.”

105.6.2.4 Department Verification Add the following to the end of the first sentence:
“or other approved method, such as reference staking, to allow the Department to independently verify the accuracy of the work, as approved by the Department.”

SECTION 106 **QUALITY**

106.3.4 Storage Revise this Section by adding the following sentence after the first sentence:
“Materials shall not be stored under or in close proximity to Highway Structures unless the Contractor receives written permission from the Resident.”

106.4.1 General - In the first sentence, remove “When required by Special Provision,” and replace with **“When required elsewhere in the Contract,”**

Revise Subsection C by replacing the last sentence with the following:

Approval of both standard and project specific QCPs shall be as outlined in paragraph B above, with the exception that the initial 14 day review period for standard plans will begin on March 1, and that the supplemental project specific QCP for the project shall be submitted a minimum of 14 days prior to any related work being performed with an initial review period of 7 days.

Revise Subsection 106.4.6 by removing it in its entirety and replace it with:

“106.4.6 QCP Non-Compliance The Contractor shall comply with the approved QCP and shall take all other steps necessary to assure a high quality project.

Failure by the Contractor to comply with the approved Quality Control Plan will result in a letter describing the violation, a mandatory work suspension, and a reduction in payment as shown in Table 106.4A below. The Contractor shall submit a letter to the Department that details the corrective action made to address the violation in their Quality Control Plan. Work may resume when the Department it is satisfied the corrective action will result in adherence to the Quality Control Plan.

Table 106.4 A - Quality Control Pay Reduction

Quality Control Plan Value*		Pay Reduction		
From More Than	To and Including	1st	2nd	3rd & Subsequent
\$0	\$500,000	\$1,000	\$2,000	\$4,000
\$500,000	\$1,000,000	\$2,000	\$4,000	\$8,000
\$1,000,000	\$3,000,000	\$5,000	\$10,000	\$20,000
\$3,000,000	and more	\$10,000	\$20,000	\$40,000

* The Quality Control Plan Value is the total bid value of all items covered by a Quality Control Plan, as detailed in the applicable specification or Special Provision.

During all periods of the Contractor’s failure to follow the approved QCP, no positive pay incentives will be calculated or paid if the Department accepts the material.

Pay reductions for failure to comply with the approved QCP are additive, and the Department will deduct any pay reductions due from amounts otherwise due the Contractor. These pay reductions are intended to encourage the Contractor to comply with its approved QCP, and are not related to the quality of the material provided.”

Amend this Section by adding the following Subsection:

“106.7.3 Early Termination of Lots In the event a lot in progress is terminated prematurely before the Department is able to take the number of acceptance samples required by the test method specified in the contract, the following will apply as applicable unless otherwise detailed in the specifications for the item:

- A. If three or more samples have been taken, then payfactors will be generated using the available samples results for the lot.
- B. If the termination was requested by the Contractor and approved by the Department prior to three samples being taken, then each property’s payfactor will be set to 0.80.
- C. If the termination was initiated by the Department prior to three samples being taken, then each property’s payfactor will be set to 1.00 for each property.”

SECTION 107
TIME

107.7.2 SCHEDULE OF LIQUIDATED DAMAGES

Revise this section by removing the numbers in the chart and replace with the following:

Original Contract Amount		Per Diem Amount of Liquidated Damages
From More Than	To and Including	Calendar Day
\$ 0	to \$ 100,000.00	\$250.00
\$ 100,000.00	to \$ 250,000.00	\$500.00
\$ 250,000.00	to \$ 500,000.00	\$650.00
\$ 500,000.00	to \$1,000,000.00	\$800.00
\$1,000,000.00	to \$2,000,000.00	\$1,000.00
\$2,000,000.00	to \$4,000,000.00	\$1,200.00
\$4,000,000.00	and More	\$2,100.00

SECTION 108
PAYMENT

108.3 Retainage - Remove the paragraph beginning with “ The Contractor may withdraw...” in its entirety.

108.4.1 Price Adjustment for Hot Mix Asphalt:

Remove this section in its entirety and replace with the following

For all contracts with hot mix asphalt in excess of 500 tons total, a price adjustment for performance graded binder will be made for the following pay items:

- Item 403.102 Hot Mix Asphalt – Special Areas**
- Item 403.206 Hot Mix Asphalt - 25 mm**
- Item 403.207 Hot Mix Asphalt - 19 mm**
- Item 403.2071 Hot Mix Asphalt - 19 mm (Polymer Modified)**
- Item 403.2072 Hot Mix Asphalt - 19 mm (Asphalt Rich Base)**
- Item 403.208 Hot Mix Asphalt - 12.5 mm**
- Item 403.2081 Hot Mix Asphalt - 12.5 mm (Polymer Modified)**
- Item 403.209 Hot Mix Asphalt - 9.5 mm (sidewalks, drives, & incidentals)**
- Item 403.210 Hot Mix Asphalt - 9.5 mm**
- Item 403.2101 Hot Mix Asphalt - 9.5 mm (Polymer Modified)**
- Item 403.2102 Hot Mix Asphalt - 9.5 mm (Asphalt Rich Base)**

Item 403.2104	Hot Mix Asphalt - 9.5 mm (Thin Lift Surface Treatment)
Item 403.21041	Hot Mix Asphalt - 9.5 mm (Polymer Modified Thin Lift Surface Treatment)
Item 403.211	Hot Mix Asphalt – Shim
Item 403.2111	Hot Mix Asphalt – Shim (Polymer Modified)
Item 403.212	Hot Mix Asphalt - 4.75 mm (Shim)
Item 403.213	Hot Mix Asphalt - 12.5 mm (base and intermediate course)
Item 403.2131	Hot Mix Asphalt - 12.5 mm (base and intermediate course Polymer Modified)
Item 403.2132	Hot Mix Asphalt - 12.5 mm (Asphalt Rich Base and intermediate course)
Item 403.214	Hot Mix Asphalt - 4.75 mm (Surface)
Item 403.235	Hot Mix Asphalt (High Performance Rubberized HMA)
Item 403.301	Hot Mix Asphalt (Asphalt Rubber Gap-Graded)
Item 404.70	Colored Hot Mix Asphalt – 9.5mm (Surface)
Item 404.72	Colored Hot Mix Asphalt – 9.5mm (Islands, sidewalks, & incidentals)
Item 461.13	Light Capital Pavement
Item 461.210	9.5 mm HMA - Paver Placed Surface
Item 462.30	Ultra-Thin Bonded Wearing Course
Item 462.301	Polymer Modified Ultra-Thin Bonded Wearing Course

Price adjustments will be based on the variance in costs for the performance graded binder component of hot mix asphalt. They will be determined as follows:

The quantity of hot mix asphalt for each pay item will be multiplied by the performance graded binder percentages given in the table below times the difference in price between the base price and the period price of asphalt cement. Adjustments will be made upward or downward, as prices increase or decrease.

Item 403.102	-6.2%
Item 403.206	-4.8%
Item 403.207	-5.2%
Item 403.2071	-5.2%
Item 403.2072	-5.8%
Item 403.208	-5.6%
Item 403.2081	-5.6%
Item 403.209	-6.2%
Item 403.210	-6.2%
Item 403.2101	-6.2%
Item 403.2102	-6.8%
Item 403.2104	-6.2%
Item 403.21041	-6.2%
Item 403.211	-6.2%
Item 403.2111	-6.2%
Item 403.212	-6.8%
Item 403.213	-5.6%

Item 403.2131–5.6%
Item 403.2132–6.2%
Item 403.214–6.8%
Item 403.235–5.5%
Item 403.301–6.2%
Item 404.70–6.2%
Item 404.72–6.2%
Item 461.13–6.7%
Item 461.210 – 6.4%
Item 462.30–0.0021 tons/SY
Item 462.301–0.0021 tons/SY

Hot Mix Asphalt: The quantity of hot mix asphalt will be determined from the quantity shown on the progress estimate for each pay period.

Base Price: The base price of performance graded binder to be used is the price per standard ton current with the bid opening date. This price is determined by using the average New England Selling Price (Excluding the Connecticut market area), as listed in the Asphalt Weekly Monitor.

Period Price: The period price of performance graded binder will be determined by the Department by using the average New England Selling Price (Excluding the Connecticut market area), listed in the Asphalt Weekly Monitor current with the paving date. The maximum Period Price for paving after the adjusted Contract Completion Date will be the Period Price on the adjusted Contract Completion Date.

SECTION 109 **CHANGES**

109.5.1 Definitions - Types of Delays

Delete Paragraph 'A' in its entirety and replace with:

"A. Excusable Delay Except as expressly provided otherwise by this Contract, an "Excusable Delay" is a Delay to the Critical Path that is directly and solely caused by (1) a weather related Event of such an unusually severe nature that a Federal Emergency Disaster is declared. The Contractor will only be entitled to an adjustment of time if the Project falls within the geographic boundaries prescribed under the disaster declaration. or (2) a flooding event at the effected location of the Project that results in a Q25 headwater elevation, or greater, but less than a Q50 headwater elevation. Theoretical headwater elevations will be determined by the Department; actual headwater elevations will be determined by the Contractor and verified by the Department or (3) An Uncontrollable Event.”

SECTION 110
INDEMNIFICATION, BONDING AND INSURANCE

110.3.9 Administrative & General Provisions

B. Defense of Claims Amend this section by adding the following sentence to the end:
“The Contractor’s insurer shall name the Department of Transportation as a released party (Releasee”) on any release or settlement agreement for settled claims.”

APPENDIX A TO DIVISION 100

Remove Section D in its entirety as this is now covered in Section 105.10 EQUAL OPPORTUNITY AND CIVIL RIGHTS.

SECTION 203
EXCAVATION AND EMBANKMENT

203.02 Materials

At the bottom of page 2-12, add as the first item in the list:

Crushed Stone, ¾ inch 703.13

203.042 Rock Excavation and Blasting

On page 2-16, add the word “**No**” to the third sentence in Section 5 Submittals, Subsection V, 1 so that it reads:

“No blasting products will be allowed on the job site if the date codes are missing.”

203.09 Preparation of Embankment Area Revise the first sentence of the second paragraph so that it reads:

“When fill material is placed against existing slopes or previously placed fill, the interface shall be continuously benched by excavating steps of sufficient width to permit operations of placing and compacting the additional material.”

SECTION 304
AGGREGATE BASE AND SUBBASE COURSE

Remove Section 304.02 Aggregate entirely and replace with the following:

“304.02 Aggregate Aggregates shall conform to the requirements specified in the following subsections of Division 700 - Materials:

Aggregate Base	Type A & B	703.06 a
Aggregate Base	Type C	703.06 b
Aggregate Subbase	Type D & E	703.06 c

Aggregate for base or subbase courses shall be material meeting the aggregate type requirements specified in the following table:

Material	Aggregate Type (Subsection 703.06)
Base Course, Crushed	¹ A, B or C
Subbase Course, Gravel	² D
¹ Will be designated on the plans ² Subbase Course, Gravel-Type E may be used below the top 9” of the subbase layer at the Contractor’s option	

For the various types of base and subbase, all shall conform to the gradation requirements of the contract at the time it is deposited on the roadbed. The Department will obtain samples from the roadbed for Acceptance prior to compaction. Oversized stones shall be removed from the aggregate before depositing on the roadway. Oversized stones for the various types are as follows:

- Type A will not pass a 2 inch square mesh sieve
- Type B and Type C will not pass a 4 inch square mesh sieve
- Type D and E will not pass a 6 inch square mesh sieve.”

The top 3” of Aggregate Base Course-Type C shall consist of Recycled Asphalt Pavement (RAP) or Untreated Aggregate Surface Course-Type B.

304.04 Shaping, Compacting, and Stabilizing Revise the first paragraph in this section by removing “according to AASHTO T 224” and “(An Adjustment Chart/Spreadsheet for this correction is available upon request) so that it reads:

“Compaction of each layer of base and subbase shall continue until a density of not less than 95% of the maximum density has been achieved for the full width and depth of the layer. The maximum density shall be determined in accordance with AASHTO T180, Method C or D, correcting for oversize particles except mixtures may have 40 percent or less retained on the ¾ inch sieve. Field density tests will be performed by the Department in accordance with AASHTO T 310.”

304.04 Shaping, Compacting, and Stabilizing Replace the tenth paragraph in this section in its entirety with:

“If the Contractor wishes to route public traffic over the completed Aggregate Base-Type A and B or Aggregate Subbase Course for a period of time greater than 48 hours, the Aggregate Base and Aggregate Subbase Course shall be constructed with a minimum 2” surcharge above the design grade. Surcharge shall be constructed with material meeting the requirements of Section 703.06(b), Subbase Aggregate-Type D. Whenever the surcharge is used, it shall be placed on all the Aggregate Base and Aggregate Subbase Course subjected to public traffic. When the surcharge is removed, it may be placed in driveways, sidewalks, approach roads, or the outer portions of the shoulders. Removal of the surcharge shall be followed immediately in succession by the fine grading of the aggregate base or subbase and construction of the HMA base layer. As per subsection 203.041 Salvage of Existing Hot Mix Asphalt Pavement, Recycled Asphalt Pavement (RAP) may be used as the top 3” of aggregate. If RAP is utilized as the top 3”, a surcharge is not required.”

304.04 Shaping, Compacting, and Stabilizing Replace the eleventh paragraph in this section in its entirety with:

“The furnishing, placing, maintaining, and removal of the surcharge will not be paid for directly, but will be considered incidental to the Aggregate Base or Aggregate Subbase course pay item.”

Section 304.07 Basis of Payment add the following:

“RAP or Untreated Aggregate Surface Course-Type B used to cap Aggregate Base Course-Type C will be paid for as Item 304.16-Aggregate Base Course -Type C.”

SECTION 307 **FULL DEPTH RECYCLED PAVEMENT**

Remove this Section in its entirety and replace with:

SECTION 307 **FULL DEPTH RECYCLING** **(UNTREATED OR TREATED WITH EMULSIFIED ASPHALT STABILIZER)**

307.01 Description This work shall consist of pulverizing a portion of the existing roadway structure into a homogenous mass, adding an emulsified asphalt stabilizer (if required) to the depth of the pulverized material specified in the contract, placing and compacting this material to the lines, grades, and dimensions shown on the plans or established by the Resident.

MATERIALS

307.02 Pulverized Material Pulverized material shall consist of the existing asphalt pavement layers and one inch or more as specified of the underlying gravel, pulverized and blended into a homogenous mass. Pulverized material will be processed to 100% passing a 2 inch square mesh sieve.

307.021 New Aggregate and Additional Recycled Material New aggregate, if required by the contract, shall meet the requirements of Subsection 703.10 - Aggregate for Untreated Surface Course and Leveling Course, Type A. Aggregate Subbase Course Gravel Type D processed to 100 percent passing a 2 inch square mesh sieve and meeting the requirements of 703.06 – Aggregate for Base and Subbase may be used in areas requiring depths greater than 2 inches. New aggregate, will be measured and paid for under the appropriate item.

Recycled material, if required, shall consist of salvaged asphalt material from the project or from off-site stockpiles that has been processed before use to 100 percent passing a 2 inch square mesh sieve. Recycled material shall be conditionally accepted at the source by the Resident. It shall be free of winter sand, granular fill, construction debris, or other materials not generally considered asphalt pavement.

Recycled material generated and salvaged from the project shall be used within the roadway limits to the extent it is available as described in 307.09. No additional payment will be made for material salvaged from the project.

Recycled material supplied from off-site stockpiles shall be paid for as described in the contract, or by contract modification.

307.022 Emulsified Asphalt Stabilizer. If required, the emulsified asphalt stabilizer shall be grade MS-2, MS-4, SS-1, or CSS-1 meeting the requirements of Subsection 702.04 Emulsified Asphalt.

307.023 Water Water shall be clean and free from deleterious concentrations of acids, alkalis, salts or other organic or chemical substances.

307.024 Portland Cement If required, Portland Cement shall be Type I or II meeting the requirements of AASHTO M85.

307.025 Hydrated Lime If required, Hydrated Lime shall meet the requirements of AASHTO M216.

EQUIPMENT

307.03 Pulverizer The pulverizer shall be a self-propelled machine, specifically manufactured for full-depth recycling work and capable of reducing the required existing materials to a size that will pass a 2 inch square mesh sieve. The machine shall be equipped with standard automatic depth controls and must maintain a consistent cutting depth and width. The machine also shall be equipped with a gauge to show depth of material being processed.

307.04 Liquid Mixer Unit or Distributor. If treatment of the recycled layer with emulsified asphalt is required by the contract, a liquid mixing unit or distributor shall be used to introduce the emulsified asphalt stabilizer into the pulverized material. The mixing unit shall contain a liquid distribution and mixing system which has been specifically manufactured for full-depth recycling work, capable of mixing the pulverized material with an evenly metered distribution of emulsified asphalt into a homogeneous mixture, to the depth and width required.

The mixing unit shall be designed, equipped, maintained, and operated so that emulsified asphalt stabilizer at constant temperature may be applied uniformly on variable widths of pulverized material up to 6 feet at readily determined and controlled rates from 0.01 to 1.06 gal/yd² with uniform pressure and with an allowable variation from any specified rate not to exceed 0.01 gal/ yd². Mixing units shall include a tachometer, pressure gages, and accurate volume measuring devices or a calibrated tank and a thermometer for measuring temperatures of tank contents.

307.041 Cement or Lime Spreader If required by the contract, spreading of the Portland Cement or Hydrated Lime shall be done with a spreader truck designed to spread dry particulate (such as Portland Cement or Lime) or other approved means to insure a uniform distribution across the roadway and minimize fugitive dust. Pneumatic application, including through a slotted pipe, will not be permitted. Other systems that have been developed include fog systems, vacuum systems, etc. Slurry applications may also be accepted. The Department reserves the right to accept or reject the method of spreading cement. The Contractor shall provide a method for verifying that the correct amount of cement is being applied.

307.05 Placement Equipment Placement of the Full Depth recycled material to the required slope and grade shall be done with an approved highway grader or by another method approved by the Resident.

307.06 Rollers The full depth recycled material shall be rolled with a vibratory pad foot roller, a vibratory steel drum soil compactor and a pneumatic tire roller. The pad foot roller drum shall have a minimum of 112 tamping feet 3 inches in height, a minimum contact area per foot of 17 inch², and a minimum width of 84 inches. The vibratory steel drum roller shall have a minimum 84 inch width single drum. The pneumatic tire roller shall meet the requirements of Section 401.10 and the minimum allowable tire pressure shall be 85 psi.

MIX DESIGN

If treatment of the recycled layer with emulsified asphalt is required by the contract, the Department will supply a mix design for the emulsified asphalt stabilized material based on test results from pavement and soil analysis taken to the design depth. The Department will provide the following information prior to construction:

1. Percent of emulsified asphalt to be used.
2. Quantity of lime or cement to be added.
3. Optimum moisture content for proper compaction.

4. Additional aggregate (if required).

After a test strip has been completed or as the work progresses, it may be necessary for the Resident to make necessary adjustments to the mix design. Changes to compensation will be in accordance with the Mix Design Special Provision.

CONSTRUCTION REQUIREMENTS

307.06 Pulverizing The entire depth of existing pavement shall be pulverized together with 1 inch or more of the underlying gravel into a homogenous mass. All pulverizing shall be done with equipment that will provide a homogenous mass of pulverized material, processed in-place, which will pass a 2 inch square mesh sieve.

307.07 Weather Limitations Full depth recycled work shall be performed when;

- A. Recycling operations will be allowed between May 15th and September 15th inclusive in Zone 1 - Areas north of US Route 2 from Gilead to Bangor and north of Route 9 from Bangor to Calais. Recycling will be allowed between May 1st and September 30th inclusive in Zone 2 - Areas south of Zone 1 including the US Route 2 and Route 9 boundaries.**
- B. The atmospheric temperature, as determined by an approved thermometer placed in the shade at the recycling location, is 50°F and rising.**
- C. When there is no standing water on the surface.**
- D. During generally dry conditions, or when weather conditions are such that proper pulverizing, mixing, grading, finishing and curing can be obtained using proper procedures, and when compaction can be accomplished as determined by the Resident.**
- E. When the surface is not frozen and when overnight temperatures are expected to be above 32°F.**
- F. Wind conditions are such that the spreading of lime or cement on the roadway ahead of the recycling machine will not adversely affect the operation.**

307.08 Surface Tolerance The complete surface of the Full Depth Recycled course shall be shaped and maintained to a tolerance, above or below the required cross sectional shape, of $\frac{3}{8}$ inch.

307.09 Full Depth Recycling Procedure New aggregate or recycled material meeting the requirements of Section 307.021 - New Aggregate and Additional Recycled Material, shall be added as necessary to restore cross-slope and/or grade before pulverizing. Locations will be shown on the plans or described in the construction notes. The Resident may add other locations while construction of the project is in progress. The Contractor will use recycled material to the extent it is available, in lieu of new aggregate. The material shall then be pulverized, processed, and blended into a homogeneous mass passing a 2 inch square mesh sieve. Material found not pulverized down to a 2 inch size will be required to be reprocessed by the recycler with successive passes until approved by the Resident.

Should the Contractor be required to add new aggregate or recycled material to restore cross-slope and/or grade after the initial pulverizing process, those areas will require re-processing to blend into a homogenous mass passing a 2 in square mesh sieve.

Sufficient water shall be added during the recycling process to maintain optimum moisture for compaction.

The resultant material from the initial pulverizing processes shall be graded and compacted to the cross-slope and profile shown on the plans or as directed by the Resident. The Contractor will also be responsible for re-establishing the existing profile grade. The completed surface of the full depth recycled course shall be shaped and maintained to a tolerance, above or below the required cross sectional shape, of $\frac{3}{8}$ inch. Areas not meeting this tolerance will be repaired as described in Section 307.091. The initial pulverizing process density requirements will be the same as Section 307.101 unless otherwise directed by the Resident.

Additives, if required, shall be introduced following completion of the initial pulverizing and blending process. Emulsified asphalt stabilizer shall be incorporated into the top of the processed material as specified in section 307.04 to the depth specified in the contract by use of the liquid mixer unit or a distributor, at the rate specified in the mix design. The emulsified asphalt shall then be uniformly blended into a homogeneous mass until an apparent uniform distribution has occurred. The rate of application may be adjusted as necessary by the Resident. Cement or lime shall be introduced as described in section 307.041. The resultant material shall be graded and compacted to the cross-slope and profile shown on the plans or as directed by the Resident. The Contractor will also be responsible for re-establishing the existing profile grade.

After final compaction, the roadway surface shall be treated with a light application of water, and rolled with pneumatic-tired rollers to create a close-knit texture. The finished layer shall be free from:

- A. Surface laminations.
- B. Segregation of fine and coarse aggregate.
- C. Corrugations, centerline differential, potholes, or any other defects that may adversely affect the performance of the layer, or any layers to be placed upon it.

The Contractor shall protect and maintain the recycled layer until a lift of pavement is applied. Any damage or defects in the layer shall be repaired immediately. An even and uniform surface shall be maintained. The recycled surface shall be swept prior to hot mix asphalt overlay placement.

307.091 Repairs Repairs and maintenance of the recycled layers, resulting from damage caused by traffic, weather or environmental conditions, or resulting from damage caused by the Contractor's operations or equipment, shall be completed at no additional cost to the Department.

For recycled layers stabilized with emulsified asphalt, low areas will be repaired using a hot mix asphalt shim. Areas up to 1 inch high can be repaired by milling or shimming with hot mix asphalt. Areas greater than 1 inch high will be repaired using a hot mix asphalt shim. All repair work will be done with the Resident's approval at the Contractor's expense.

TESTING REQUIREMENTS

307.10 Quality Control The Contractor shall operate in accordance with the approved Quality Control Plan (QCP) to assure a product meeting the contract requirements. The QCP shall meet the requirements of Section 106.4 - Quality Control and this Section. The Contractor shall not begin recycling operations until the Department approves the QCP in writing. Prior to performing any recycling process, the Department and the Contractor shall hold a Pre-recycle conference to discuss the recycling schedule, type and amount of equipment to be used, sequence of operations, and traffic control. A copy of the QC random numbers to be used on the project shall be provided to the Resident. All field supervisors including the responsible onsite recycling process supervisor shall attend this meeting.

The QCP shall address any items that affect the quality of the Recycling Process including, but not limited to, the following:

- A. Sources for all materials, including New Aggregate and Additional Recycled Material.
- B. Make and type of rollers including weight, weight per inch of steel wheels, and average contact pressure for pneumatic tired rollers.
- C. Testing Plan.
- D. Recycling operations including recycling speed, methods to ensure that segregation is minimized, grading and compacting operations.
- E. Methods for protecting the finished product from damage and procedures for any necessary corrective action.
- F. Method of grade checks.
- G. Examples of Quality Control forms.
- H. Name, responsibilities, and qualifications of the Responsible onsite Recycling Supervisor experienced and knowledgeable with the process.
- I. A note that all testing will be done in accordance with AASHTO and MDOT/ACM procedures.

The Project Superintendent shall be named in the QCP, and the responsibilities for successful implementation of the QCP shall be outlined.

The Contractor shall sample, test, and evaluate the full depth reclamation process in accordance with the following minimum frequencies:

MINIMUM QUALITY CONTROL FREQUENCIES

Test or Action	Frequency	Test Method
Density	1 per 1000 feet / lane	AASHTO T 310
Air Temperature	4 per day at even intervals	

Surface Temperature	At the beginning and end of each days operation	
Yield of all materials (Daily yield, yield since last test, and total project yield.)	1 per 1000 ft/lane	

The Department may view any QC test and request a QC test at any time. The Contractor shall submit all QC test reports and summaries in writing, signed by the appropriate technician, to the Department’s onsite representative by 1:00 P.M. on the next working day, except when otherwise noted in the QCP due to local restrictions. The Contractor shall make all test results, including randomly sampled densities, available to the Department onsite.

The Contractor shall cease recycling operations whenever one of the following occurs:

- A. The Contractor fails to follow the approved QCP.
- B. The Contractor fails to achieve 98 percent density after corrective action has been taken.
- C. The finished product is visually defective, as determined by the Resident.
- D. The computed yield differs from the mix design by 10 percent or more.

Recycling operations shall not resume until the Department approves the corrective action to be taken.

307.101 Test Strip The contractor shall assemble all items of equipment for the recycling operation on the first day of the recycling work. The Contractor shall construct a test strip for the project at a location approved by the Resident. The Responsible onsite Recycling Supervisor will work with Department personnel to determine the suitability of the mixed material, moisture control within the mixed material, and compaction and surface finish. The test strip section is required to:

- A. Demonstrate that the equipment and processes can produce recycled layers to meet the requirements specified in these special provisions.
- B. Determine the effect on the gradation of the recycled material by varying the forward speed of the recycling machine and the rotation rate of the milling drum.

- C. Determine the optimum moisture necessary to achieve proper compaction of the recycled layer.
- D. Determine the sequence and manner of rolling necessary to obtain the compaction requirements and establish a target density. The Contractor and the Department will both conduct testing with their respective gauges at this time.

The test strip shall be at least 300 feet in length of a full lane-width (or a half-road width). Full recycling production will not start until a passing test strip has been accomplished. If a test strip fails to meet the requirements of this specification, the Contractor will be required to repair or replace the test strip to the satisfaction of the Resident. Any repairs, replacement, or duplication of the test strip will be at the Contractor's expense.

After the test strip has been pulverized, and the roadway brought to proper shape, the Contractor shall add water until it is determined that optimum moisture has been obtained. The test strip shall then be rolled using the specified compaction equipment as directed until the density readings show an increase in dry density of less than 1 pcf for the final four roller passes of each roller. The Contractor and Department will each determine a target density using their respective gauges by performing several additional density tests and averaging them. The average of these tests will be used as the target density of the recycled material for QC and Acceptance purposes.

Following completion of the test strip, compaction of the material shall continue until a density of not less than 98 percent of the test strip target density has been achieved for the full width and depth of the layer. During the construction and compaction of the Full Depth Recycled base, should three consecutive Acceptance test results for density fail to meet a minimum of 95 percent of the target density, or exceed 102 percent of target density, a new test strip shall be constructed.

ACCEPTANCE TEST FREQUENCY

Property	Frequency	Test Method
In-place Density	1 per 2000 ft / lane	AASHTO T 310

307.102 Curing. No new pavement shall be placed on the full depth recycled pavement until curing has reduced the moisture content to 1 percent or less by total weight of the mixture, or a curing period of 4 days has elapsed, whichever comes first.

307.11 Method of Measurement Full Depth Recycled Pavement (Untreated or Treated with Emulsified Asphalt Stabilizer) will be measured by the square yard.

307.12 Basis of Payment The accepted quantity of Full Depth Recycled Asphalt Pavement (Untreated or Treated with Emulsified Asphalt Stabilizer) will be paid for at the contract unit price per square yard, complete in-place which price will be full compensation for furnishing all equipment, materials and labor for pulverizing, blending, placing, grading, compacting, and for all incidentals necessary to complete the work.

The addition of materials to restore profile grade and/or cross-slope in areas shown on the plans or described in the construction notes will be paid separately under designated pay items within the contract. No additional payment will be made for materials salvaged from the project.

Payments will be made under:

<u>Pay Item</u>	<u>Pay Unit</u>
307.331 Full Depth Recycled Pavement (Untreated)	Square Yard
307.332 Full Depth Recycled Pavement (with Emulsified Asphalt Stabilizer) 5 in. depth	Square Yard
307.333 Full Depth Recycled Pavement (with Emulsified Asphalt Stabilizer) 6 in. depth	Square Yard

SECTION 411
UNTREATED AGGREGATE SURFACE COURSE

411.02 – Aggregate Add the following to the end of the first sentence: “- Type A”

SECTION 501
FOUNDATION PILES

501.047 Splicing Piles Remove subsection 501.047 d 3, which states “Written welding procedures do not need to be submitted”, in its entirety.

501.05 – Method of Measurement

- b. Piles Furnished – After the second sentence, add the sentence “**Measurement will not include any pile tips**”.
- c. Piles in Place – Add the sentence to the end of the second paragraph, “**Measurement will include the pile tips**”.
- d. Pile Tips – Add the words “**on the Pile**” to the end of the sentence.

SECTION 502
STRUCTURAL CONCRETE

502.05 Composition and Proportioning

Replace Table 1 with

TABLE 1

Concrete CLASS	Minimum Compressive Strength (PSI)	Permeability as indicated by Surface Resistivity (KOhm-cm)	Entrained Air (%)		Notes
			LSL	USL	
S	3,000	LSL	LSL	USL	4,5
		N/A	N/A	N/A	
A	4,000	14	6.0	9.0	1,4,5
P	-----	-----	5.5	7.5	1,2,3,4
LP	5,000	17	6.0	9.0	1,4,5
Fill	3,000	N/A	6.0	9.0	4,5

In the list of information submitted by the contractor for a mix design:

Item J Replace “Target Coulomb Value.” with “Target KOhm-cm Value.”

Note #1 - Remove, “...**Standard Specification Section 711.05, Protective Coating for Concrete Surfaces, and per the manufacturer’s recommendations, at no additional cost to the Department.**” and replace with, “...**Standard Specification Section 515, Protective Coating for Concrete Surfaces, at no additional cost to the Department.**”

502.1703 Acceptance Methods A and B

In the paragraph that starts with “The Department will take Acceptance...” Remove the word chloride from chloride permeability in the last sentence.

Replace the paragraph starting with “Rapid Chloride Permeability specimens...” With the following:

“Surface Resistivity specimens will be tested by the Department in accordance with AASHTO TP-95 at an age \geq 56 days. Four 4 inch x 8 inch cylinders will be cast per subplot placed. The average of three concrete specimens per subplot will constitute a test result and this average will be used to determine the permeability for pay adjustment computations.”

502.1706 Acceptance Method C

Remove in its entirety and Replace with:

502.1706 Acceptance Method C The Department will determine the acceptability of the concrete through Acceptance testing. Acceptance tests will include compressive strength, air content and permeability. Method C concrete not meeting the requirements listed in Table 1 shall be removed and replaced at no cost to the Department. At the Department’s sole discretion, material not meeting requirements may be left in place and paid for at a reduced price as described in Section 502.195.

502.1707 Resolution of Disputed Acceptance Test Results

Section B

Remove “Rapid Chloride” from the section heading.

In paragraph 4 replace T-277 with TP-95

502.192 Pay Adjustment for Chloride Permeability

Remove “Chloride” from the heading and from the first sentence.

Replace the sentence that starts with “values greater than...” and replace with “values less than 10 KOhms-cm for Class A concrete or 11 KOhms-cm for Class LP concrete shall be subject to rejection and replacement, at no additional cost to the Department.”

502.194 Pay Adjustments for Compressive Strength, Chloride Permeability and Air Content, Methods A and B

Remove the word “Chloride” from the section heading and from the equation for CPF.

502.195 Pay Adjustment Method C

In Table 6: Method C Pay Reductions (page 5-53)

Under “Entrained Air” for “Class Fill”, in the first line, change from “< 4.0 (Removal)” to “< **4.5 (Removal)**”

In Table 6: Method C PAY REDUCTIONS, revise the Chloride Permeability section by removing it in its entirety and replacing it with:

Surface Resistivity {Permeability in Kohm-cms and Pay Reduction per CY}			
15-16 (\$50)	13 (\$25)	N/A	N/A
13-14 (\$75)	12(\$50)	N/A	N/A
12 (\$100)	11 (\$75)	N/A	N/A
11 (\$125)	10 (\$100)	N/A	N/A
< 11 (Removal)	< 10 (Removal)	N/A	N/A

SECTION 503 **REINFORCING STEEL**

503.06 Placing and Fastening Revise this Subsection by removing, in its entirety, the paragraph which begins, “Stainless steel reinforcement shall not be tied to any other type of reinforcement.....”

SECTION 504 **STRUCTURAL STEEL**

504.06 Inspection Revise this section by removing the last sentence in the first paragraph which reads “Make the results of all measurements and testing available to the QAI.” And replace with **“Provide a copy of all measurements and testing to the QAI.”**

504.08 Rejections Amend this section by adding the following sentences to the end of the 1st paragraph: **“Structural Defects: Repair structural defects only with the approval of the Fabrication Engineer. Submit a nonconformance report (NCR) to the Fabrication Engineer with a proposed repair procedure. Do not perform structural repairs without an NCR that has been reviewed by the Fabrication Engineer. Give the QAI adequate notice prior to beginning structural repairs.”**

504.13 Unpainted Steel Revise this section by removing the third sentence which reads “Clean steel that is abrasive-blast cleaned prior to fabrication in accordance with SSPC-SP 1 Solvent Cleaning after fabrication is complete.” And replace it with: **“Clean steel that is abrasive cleaned prior to fabrication in accordance with SSPC-SP 6 shall be cleaned in accordance with SSPC-SP 1 Solvent Cleaning after fabrication is complete.”**

504.26 Welding Remove the second paragraph beginning with “The range of heat....” in its entirety.

504.29 Welding ASTM A 709 HPS 70W Steel. Remove the third paragraph beginning with “Make Weld runoff tabs...” in its entirety.

504.55 Field Welding Revise the first paragraph by replacing the word “Resident” with **“Fabrication Engineer”**.

504.60 Holes for Base Plates Revise this section by removing the second sentence and replacing it with **“The roughness shall not exceed condition of AWS C4.1-77, Sample 4.”**

504.64 Non Destructive Testing-Ancillary Bridge Products and Support Structures Revise the first sentence under number 1 by adding **“fillet or partial penetration welds on”** between the words “of” and “each” so the first sentence reads “ Examine ten percent of fillet or partial penetration welds on each production lot using Magnetic Particle (MT) inspection”.

SECTION 506

SHOP APPLIED PROTECTIVE COATING - STEEL

Revise this section by removing the subsection THERMAL SPRAY COATING entirely and replace with:

THERMAL SPRAY COATING

506.30 Description This work shall consist of surface preparation and application of Thermal Spray Coatings (TSC) in accordance with the Plans and this Specification. Application of TSC to steel substrate shall be done in accordance with requirements, recommendations and appendices of the current Joint Standard *NACE NO. 12/AWS C2.23M/SSPC-CS 23.00, Specification for the Application of Thermal Spray Coatings (Metallizing) of Aluminum, Zinc, and Their Alloys and Composites for the Corrosion Protection of Steel* (The Standard) and this Specification.

The applicator shall have a minimum of five years of experience and shall provide copies of application procedures, operator qualifications, QC Manuals and repair procedures.

506.31 Submittals Submit an application procedure and QC Plan for review by the Department prior to beginning work. Submit a certified analysis of the feedstock to the Department. Submit sample copies of QC records for review. Submit copies of applicator qualifications, job history, etc. Provide the name and qualifications of the QCI.

506.32 Surface Preparation Prior to abrasive blast cleaning, round all corners exposed in the assembled product to approximately a 3/32 inch radius. A series of tangents to the approximate radius will be considered acceptable. Remove hardened condition on thermal cut surfaces. Abrasive blast clean all surfaces to be coated in accordance with The Standard and *SSPC-SP 5, White Metal Blast Cleaning* (SP 5). Use SSPC-VIS. 1 as a visual standard to determine acceptable cleanliness. Inspect the substrate immediately before spray application.

The anchor profile shall be per The Standard (minimum 2.5 mils). Measure and record the anchor profile in accordance with *ASTM D4417 Method B or C (Replica Tape) or both* on each plane to be sprayed or at 120 ° intervals on pipe or tube. Measure at the frequency in The Standard. Angular blast media shall conform with The Standard. If the anchor profile fails to meet the minimum required profile, re-blast the substrate until the required anchor profile is achieved.

If compressed air is used for abrasive blast cleaning, perform a blotter test in accordance with *ASTM D4285* at the beginning of each shift. Empty moisture traps at the beginning of each shift and at any time thereafter when moisture appears to be present on the substrate. Notify the QAI prior to performing the test in order that the QAI can witness the blotter test.

506.33 TSC Requirements The coating thickness shall be a minimum of 14 mils. The DFT on faying surfaces shall not exceed the thickness tested for Class B slip coefficient rating. The TSC shall have a minimum tensile bond per The Standard. Test the tensile bond in

accordance with ASTM D4541. The frequency of testing shall be per The Standard. The test location will be as directed by the QAI. The specified tensile force shall be applied to the TSC and removed. If the test does not reveal a failure of the TSC, the tensile bond shall be considered acceptable. Repair or recoat unacceptable work. Tensile testing may be performed on witness panels coated by each technician on each shift TSC is applied; notify the QAI so witness panel coating may be observed.

Perform a bend test as described The Standard, at the beginning of each shift. If the bend test fails, take corrective action and perform another test. After performing the bend test successfully a number of times, the Fabrication Engineer may reduce the frequency of testing. Document the results of the tensile bond test and bend test and provide the results to the Department. Satisfactory bend test results with 7-12 mils thickness will be acceptable.

The TSC shall have a uniform appearance, free from blistering, cracks, loose particles, or exposed steel substrate when examined with 10-X magnification.

506.34 TSC Application Record the batch and lot numbers of the consumables. Measure ~~the~~ environmental conditions in the immediate vicinity of ~~the~~ piece(s) being coated during the coating operation and during the entire cure period for intermediate and top coat. Provide two data loggers capable of measuring ambient humidity and temperature. The data loggers shall come with software that can download the data onto a computer. Print out the data and provide a copy to the QAI for review prior to applying the subsequent coat of paint. Place the data loggers in the immediate vicinity of the coating operation during the entire application and curing cycle. The data will be used to determine that the cure/recoat time requirements for each coat have been met. Failure to comply will result in the coating being cured for the maximum time necessary to assure adequate cure as determined by the Fabrication Engineer.

506.35 Seal Coat and Top Coat Application (Paint) Apply a wash primer and/or seal coat of 2 to 3 mils thickness. The seal coat shall be compatible with an epoxy intermediate coat and a polyurethane top coat from the NEPCOAT QPL. Provide certification of compatibility between the seal coat and intermediate coat from the intermediate coat/top coat manufacturer. Top flanges of beams requiring shear connectors shall receive a seal coat only.

506.36 Materials Provide materials in accordance with 506.11.

506.37 Mixing and Application Mix and apply in accordance with 506.14.

506.38 Dry Film Thickness Measure and record the DFT in accordance with 506.15.

506.39 Touch-up and Repairs Repair damage to TSC by re-blasting the damaged area and re-applying TSC in accordance with this Specification. Perform touch-up and repairs to paint in accordance with 506.16.

SECTION 507 **RAILINGS**

507.07 Aluminum Bridge Railing Amend the paragraph beginning with “Welding shall be done in conformance...” by adding after “Aluminum D1.2” the words “(AWS D1.2)”. Add the following as a new paragraph after this paragraph:

“All welds shall be inspected and conform with AWS D1.2, Clause 5, Inspection. 100% of welds shall be visually examined (VT). In addition to VT, 10% of all partial joint penetration (PJP) and fillet welds shall be dye penetrant tested (PT); locations to be PT examined will be designated by the QAI. 25% of complete joint penetration (CJP) welds shall be either, ultrasonic tested (UT) or PT based on the thinner material in the welded joint; joints with thinner material thicknesses less than 0.25 inch shall be PT examined and joints with thinner material thickness equal or greater than 0.25 inch shall be UT examined. Locations to be UT examined will be designated by the QAI. Extent of testing shall conform with AWS D1.2, Clause 5.”

SECTION 510 **SPECIAL DETOURS**

510.032 Geometric and Approach Design a. Horizontal alignment
The third paragraph of this section is revised to read as follows:

“The roadway width shall be increased on curved portions of the Special Detour to account for the off tracking characteristics of WB-62 vehicle in accordance with the AASHTO publication A Policy On Geometric Design of Highways and Streets (the Green Book), chapter 3 table entitled Design Widths of Pavements for Turning Roadways.”

SECTION 527 **ENERGY ABSORBING UNIT**

527.02 Materials This section is revised to read as follows.

527.02 Materials Work Zone Crash Cushions must comply with NCHRP Report 350. Work Zone Crash Cushions shall be selected from MaineDOT’s Qualified Products List of Crash Cushions / Impact Attenuators, or an approved equal.

SECTION 534 **PRECAST STRUCTURAL CONCRETE**

534.14 Process Control Test Cylinders
Revise this subsection to read:

“534.14 Acceptance and Quality Control Testing of Concrete Refer to Section 712.061.”

534.20 Installation of Precast Units revise this section by removing the first two paragraphs and replacing them with:

534.20 Installation of Precast Units When footings are required, install the precast units on concrete footings that have reached a compressive strength of at least 3,000 psi. Construct the completed footing surface to the lines and grades shown on the Plans. When checked with a 10 foot straightedge, the surface shall not vary more than one-quarter inch in 10 feet. The footing keyway shall be filled with a Department-approved non-shrink flowable cementitious grout with a design compressive strength of at least 5,000 psi.

Three sided frame and box culvert joints shall be sealed with a Department-approved flexible joint sealant in accordance ASTM C990. Joints shall be closed tight. Culvert units shall be equipped with joint closure mechanisms to draw units together and close joints to the required opening.

SECTION 535 **PRECAST, PRESTRESSED CONCRETE SUPERSTRUCTURE**

Section 535.08 – Quality Assurance

Revise the second paragraph to read:

“The QAI will perform acceptance sampling and testing and will witness or review documentation, workmanship and testing to assure the Work is being performed in accordance with the Contract Documents.”

Section 535.15 - Process Control Test Cylinders

Revise the first paragraph to read:

“535.15 Acceptance and Quality Control Testing of Concrete Acceptance of structural precast/prestressed units, for each day’s production, will be determined by the Department, based on compliance with this specification and satisfactory concrete testing results. At least once per week, the QAI will make 2 concrete cylinders (6 cylinders when the Contract includes permeability requirements) for use by the Department; cylinders shall be standard cured in accordance with AASHTO T23 (ASTM C31). The QAI will perform entrained air content and slump flow testing, determine water-cement ratio and determine temperature of the sampled concrete at the time of cylinder casting. All testing equipment required by the QAI to perform this testing shall be provided in accordance with Standard Specification Section 502.041, Testing Equipment. In addition, the Contractor shall provide a slump cone meeting the requirements of AASHTO T 119. Providing and maintaining testing and curing equipment shall be considered incidental to the work and no additional payment will be made.”

Insert the following as the second paragraph of Section 535.15:

“Quality Control concrete test cylinders shall be made for each day’s cast and each form bed used. Cylinders tested to determine strand release strength and design strength shall be field cured in accordance with AASHTO T23 (ASTM C31). 28 day cylinders shall be standard

cured. Record unit identification, entrained air content, water-cement ratio, slump flow and temperature of the sampled concrete at the time of cylinder casting.”

SECTION 603 **PIPE CULVERTS AND STORM DRAINS**

603.02 Materials Amend this section by adding the following two paragraphs to the end:

“Reinforced Concrete Pipe (RCP) with inside diameters of 10 ft. (120in) or greater shall be designed, fabricated and accepted in accordance with Section 534- Precast Structural Concrete.

All Pipes or Culverts with inside diameters of 10 ft. (120in) or greater shall be designed using the current version of the AASHTO LRFD Bridge Design Specifications with Maine Modified HL-93 for Strength 1.”

SECTION 604 **MANHOLES, INLETS CATCH BASINS**

604.04 Adjusting Catch Basins and Manholes,

Add the following paragraph to the end of 604.04 b:

The Department will allow the use of metal ring inserts set into the manhole top frame or composite risers placed beneath the manhole frame to adjust manhole slope and grade for paving projects. The use of metal ring inserts shall be in accordance with 604.04 d. Ring Insert Requirements. The use of composite risers shall be in accordance with 604.04 e. Composite Riser Requirements.

Add the following paragraph after the first paragraph of 604.04 c:

The Department will allow the use of metal ring inserts set into the manhole top frame or composite risers placed beneath the manhole frame to adjust manhole slope and grade for paving projects. The use of metal ring inserts shall be in accordance with 604.04 d. Ring Insert Requirements. The use of composite risers shall be in accordance with 604.04 e. Composite Riser Requirements.

Add the following sections to 604.04:

d. Ring Insert Requirements Ring inserts to adjust manhole top frame slope and grade will be allowed in accordance with the following requirements:

1) Materials

- i. All ring inserts must be made of iron. *Multiple ring inserts will not be allowed.* The single ring insert may be any height up to a maximum of 2 inches tall.
 - ii. Ring inserts shall not be welded to the manhole frame to prevent brittle failure of the cast iron frame.
 - iii. Ring inserts shall be fastened to the manhole frame using liquid steel-filled epoxy such as Loctite Fixmaster Steel Liquid or equivalent. The epoxy shall be installed in accordance with the manufacturer's recommendations.
- 2) Where Ring Inserts May/May Not Be Used
- i. MaineDOT will allow the use of a single manhole ring insert to raise manholes on state and state-aid highways.
 - ii. *Manhole ring inserts may not be used along state and state-aid highway sections where the speed limit is 40 miles per hour or more.* The standard brick and mortar or flat composite risers beneath the manhole frame must be used at these locations.
- 3) Construction Requirements For The Use of Iron Manhole Ring Inserts
- i. Wherever iron ring inserts are used to raise manhole top elevations, the rings shall be fastened to the existing manhole frame using liquid steel-filled epoxy. The liquid steel-filled epoxy shall be placed evenly around the entire manhole frame before placing the ring insert. *Unbonded ring inserts will not be allowed.* If the manufacturer's recommended construction practices result in loose or unacceptable manhole cover restraint, standard brick and mortar or flat composite risers beneath the manhole frame must be used at these locations.

e. Composite Riser Requirements Flat or beveled, doughnut-shaped, composite risers placed beneath the manhole frame to adjust slope and grade are allowed. The composite riser shall be fastened to both the top of the concrete cone and bottom of the manhole frame with the manufacturer's recommended epoxy. Composite risers may be used at all locations on state and state-aid highways under any legal speed limit without restriction.

SECTION 606 **GUARDRAIL**

606.09 Basis of Payment Amend the first sentence of the eighth paragraph of this subsection by removing the word "meter" and replace it with "linear foot".

SECTION 608
SIDEWALKS

608.021 Sidewalk Materials Revise this section by removing the second paragraph which begins with “Portland cement concrete shall...” in its entirety and replace with **“Portland cement concrete shall be Class A and meet the requirements of Section 502, Structural Concrete.”**

SECTION 609
CURB

609.03 Vertical Stone Curb, Terminal Section and Transition Sections and Portland Cement Concrete Curb, Terminal Sections and Transition Sections

Amend this section by adding the following paragraph to the end of it:

“The Contractor may elect to substitute concrete to backfill Stone Curbing or Stone Edging at their option. If the concrete backfill option is elected, the following is added to Standard Specification 609 – Curb”

609.02 Materials Amend this section by adding the following to it:

Portland cement and Portland Pozzolan Cement	701.01
Water	701.02
Fine Aggregate for Concrete	703.01
Coarse Aggregate for Concrete	703.02

The Contractor shall submit a concrete mix design for the Portland Cement Concrete to the Resident, with a minimum designed compressive strength of 3000 psi Class Fill concrete.

609.10 Basis of Payment Revise by changing the fifth paragraph which begins with “There will be no separate payment...” this section by removing the word “cement” and replacing it with **“concrete fill, mortar”**.

SECTION 619
MULCH

619.07 Basis of Payment Amend this section by adding the words **“; Bark Mulch and Erosion Control Mix will be paid for by the Cubic Yard;”** into the first sentence so that it reads:

“The accepted areas mulched will be paid for at the contract price per unit; Bark Mulch and Erosion Control Mix will be paid for by the Cubic Yard; which shall be full compensation for furnishing and spreading the hay or straw and mulch binder, cellulose fiber mulch, bark mulch or erosion control mix.

Revise the second sentence by removing “ for pay item 619.1201” So that it reads:

“When Mulch is measured in Bales, each bale will be paid for at 60% of the contract price per Unit”.

Revise this section by removing all pay items and replace them with the following:

619.12 Mulch	Unit
619.13 Bark Mulch	Cubic Yard
619.14 Erosion Control Mix	Cubic Yard

SECTION 621 **LANDSCAPING**

621.0002 Materials - General

In the list of items change “Organic Humus” to “**Humus**”.

621.0019 Plant Pits and Beds

c Class A Planting

In the third paragraph beginning with “ The plant pit...” change “½ inch” to “**1 inch**”

SECTION 626 **FOUNDATIONS, CONDUIT AND JUNCTION BOXES FOR HIGHWAY SIGNING, LIGHTING AND SIGNALS**

626.02 General Amend the Material list by adding the following to the list:

Gravel Borrow	703.20
---------------	--------

Revise the Material List by removing:

Prewired Conduit	715.04
Metallic Junction and Fuse Box	715.05

626.021 Miscellaneous Material Amend this section by adding the following to the end of it:

“All concrete for concrete encasement of conduit shall be Fill Class concrete in accordance with the applicable requirements of Section 502 – Structural Concrete.”

Amend the third paragraph that begins with “If grouting is necessary...” by adding **“included on the Qualified Product List and”** after the word “material”.

626.03 General Amend this section by adding the following section to the end of it

“626.0301 Electrical Supply Lines and Service Connections The following requirements shall apply to Electric Supply Lines and Service Connections feeding traffic signalization equipment control boxes and lighting breaker boxes.

Whenever possible, the meter and breaker panel feeding traffic signal control boxes or lighting control boxes shall be constructed within 30 feet of the service drop pole.

All underground service connections that are constructed in trenches and carrying Secondary Utility Power to a MaineDOT meter and breaker panel, or, directly to MaineDOT traffic signalization control cabinets or lighting breaker boxes shall be in Rigid Metal Conduit or concrete encased PVC conduit.

Where trenchless technologies are employed to install the service connection conduit, Schedule 120 PVC conduit shall be used for the trenchless bore section of conduit. In addition, concrete encasement shall be used for any PVC conduit placed in trench sections and carrying Secondary Utility Power more than 10 feet before or after the limits of the trenchless bore conduit.

The construction practices described above shall be used for service connections up to a maximum of 600 feet. There may be rare exceptional cases where the service connection must exceed 600 feet. In these cases, the power companies may require primary power be run over 600 feet for the purpose of power consumption and dependable service. These cases will be evaluated on a case-by-case basis for alternate power feed methods and/or the need for steel or concrete encased conduit.”

626.031 Conduit Revise this section by removing the second paragraph which begins with “Trenches for conduits...” and replace it with the following:

“Trenches for conduits shall be excavated to a width that will permit proper installation of the conduit and to a minimum depth of 3 feet below finish grade as measured from the top of the conduit. If deeper depths are required, the conduit shall be installed at the depth shown on the plans or as directed. Conduit shall not interfere with poles, guardrail posts, sign foundations or other objects.”

Amend the third paragraph which begins with “All junction or pull boxes...” by adding **“concrete, in accordance with the applicable requirements of Section 502 – Structural Concrete,”** after Class LP.

Revise the fifth paragraph which begins with “After the trench has been...” by adding the following to the end of it:

“Where concrete encasement is required around the conduit, backfilling with approved material may begin adjacent to and above the encased conduit no sooner than 24 hours after concrete placement.”

Remove the following:

“All underground conduit shall be placed to at least the depth shown on the plans and shall not interfere with poles, guardrail posts, sign foundations or other objects.”

Revise the paragraph beginning with “All conduit ends shall...” by removing “Prewired Conduit shall be sealed during construction to prevent entry of moisture, dirt, or rocks.”

626.033 Polyvinylchloride Conduit Installation Amend the first paragraph of this section which begins with “Polyvinylchloride conduit and High Density...” by adding the following to the end of it:

“In addition, PVC conduit used for Electrical Supply Lines and Services constructed as underground service connections in trenches and carrying Secondary Utility Power to a MaineDOT meter and breaker panel, or, directly to MaineDOT traffic signalization control cabinets or lighting breaker boxes shall be concrete encased. When trenchless technologies are used to install PVC conduit, concrete encasement shall not be required.

Concrete encasement shall consist of a minimum of 4 inches of concrete above, below and on both sides of the conduit that shall have a minimum compressive strength of 3000 psi and a maximum aggregate size of 1-inch (Fill Class concrete). The concrete encasement may be backfilled no sooner than 24 hours after placement. “

“NON-METALLIC UNDER PAVEMENT CONDUIT INSTALLATION

Where noted on the drawings, non-metallic under pavement conduit of schedule 80 or greater rating shall be provided to facilitate conduit crossing of the existing highway and ramps without disruption to the existing highway and ramp pavement surface. The non-metallic under pavement conduit shall be hydraulically jacked or directional bored below the highway and ramp at a depth of not less than (36 inches). Under pavement conduit shall extend for a distance of (10 feet) beyond the highway or ramp edge at each side.”

Amend the sixth paragraph which begins with “Where PVC conduit runs are...” by changing “3 inch minimum bedding” to “**6 inch minimum bedding**”.

626.034 Concrete Foundations

Revise this section by removing the third paragraph which begins with “In the absence of Design Requirements...” in its entirety and replace with the following:

“In the absence of design requirements being provided on the plans, the Contractor shall prepare and submit the foundation design(s) to the Department for review. The Contractor may propose an alternate shallow spread footing or drilled shaft configuration/design than that set forth on the drawings. Design shall be in accordance with AASHTO LRFD Specifications for Structural Supports for Highway Sign, Luminaires and Traffic Signals,

current edition; AASHTO LRFD Bridge Design Specifications, current edition; and FHWA-NHI-10-016 Drilled Shafts, Construction Procedures and Design Methods, current edition. Where conflicting requirements occur, the more stringent requirements shall govern. In addition to other design requirements, foundation design shall account for Torsion for which a minimum Factor of Safety equal to 1.2 shall be achieved. In evaluating axial capacity and torsional resistance in cohesionless soils, load transfer coefficient or side resistance coefficient (beta, β) will be used in accordance with Subsection 13.3.5.1 of FHWA-NHI-10-016, with beta determined in accordance with Equations 13-13 and 13-11 for silty sands to sandy silts (with varying amounts of gravel). The design criteria for the resistance of drilled shaft and spread footing foundations against overturning, sliding and bearing capacity failure shall meet the requirements of Section 4 of AASHTO LRFD Bridge Design Specifications, current edition. The structural design of foundations shall meet the requirements of AASHTO LRFD Bridge Design Specifications, current edition. The Contractor shall submit to the Department for review, three (3) copies of detailed plans and calculations of the proposed design. Design shall be prepared and sealed by a Professional Engineer licensed in the State of Maine. Construction of foundation(s) shall not commence until the Department has reviewed the foundation design.”

On Page 6-85, add the following paragraph before the paragraph beginning with “Drilled shafts shall not be...”.

“ No foundation design will be required for 18- and 24-inch diameter foundations for structures less than 30-feet tall and with no projecting arms. A foundation design prepared by a Professional Engineer licensed in accordance with the laws of the State of Maine will be required for all other foundations Precast foundations will be permitted for 18 and 24-inch diameter foundations for structures less than 30-feet tall and with no projecting arms. Where precast foundations are permitted flowable concrete fill shall be used as backfill in the annular space, and placed from the bottom up. Construction of precast foundations shall conform to the Standard Details and all requirements of Section 712.061 except that the concrete shall have a minimum permeability of 17 kOhm-cm and the use of calcium nitrite will not be required. “

On Page 6-86, Revise the paragraph beginning with “Concrete for drilled shafts...” so that a portion of it reads as follows:

“...The Contractor shall provide temporary dewatering of excavations for foundations such that concrete is placed in the dry. Concrete for drilled shafts shall be placed in accordance with Section 502.10 as temporary casing is withdrawn to prevent debris from contaminating the foundation and to ensure concrete is cast against the surrounding soil. Concrete for drilled shafts and spread footings shall be Class LP in accordance with Section 502 - Structural Concrete. Precast foundations will not be permitted except as specified above in this Section. Backfill for spread footing foundations shall be Gravel Borrow meeting the requirements of Section 703.20 - Gravel Borrow.....”

626.05 Basis of Payment Amend this section by removing the following paragraphs:

The one which starts with “Payment will be made for the total number of linear feet of prewired conduit...”

The one which starts with “Prewired conduit within the foundations...”

Amend this subsection by adding the following paragraph and Pay Items:

“Payment will be made for the total number of linear feet of under pavement conduit actually furnished, installed and accepted at the contract price per linear foot. This price shall include the cost of: furnishing and installing the conduit; excavating; furnishing special backfilling materials, pull wire, fittings, grounding and bonding; test cleaning interiors of conduits and all materials, labor, equipment and incidentals necessary to complete the work.”

Pay Item	PayUnit
626.221 Non-metallic Conduit, Concrete Encased	Linear Foot
626.251 Non-Metallic Under pavement Conduit (Schedule 80 or greater rating)	Linear Foot

Remove the following Pay Items:

626.23 Prewired Conduit Secondary Wiring	Linear Foot
626.24 Prewired Conduit Primary Wiring	Linear Foot

SECTION 627 **PAVEMENT MARKINGS**

Revise this section by removing it in its entirety and replacing with the following:

627.01 Description This work shall consist of furnishing and placing reflectorized pavement lines and markings, removing pavement lines and markings, and furnishing and applying reflectorized paint to curbing in reasonably close conformity with the plans and as designated.

627.02 Materials Materials shall conform to the requirements specified in the following Sections of Division 700 - Materials.

Pavement Marking Paint	708.03
Reflectorized Plastic Pavement Marking	712.05

Temporary Bi-directional Yellow Delineators shall be Temporary Object Markers (T.O.M.) as manufactured by the Davidson Plastic Company, 18726 East Valley Highway, Kent, WA 98031 or an approved equal.

627.04 General All pavement lines and markings shall be applied in accordance with the latest edition of Manual on Uniform Traffic Control Devices.

Longitudinal lines placed on tangent roadway segments shall be straight and true. Longitudinal lines placed on curves shall be continuous smoothly curved lines consistent with the roadway alignment. All pavement markings placed shall meet the tolerance limits shown on the plans.

Unless otherwise shown on the plans, non-interstate lines shall be 4 inches wide and broken lines shall consist of alternate 10 foot painted line segments and 30 foot gaps. On controlled access divided highways and on the interstate system lines shall be 6 inches wide and broken lines shall consist of alternate 15 foot painted line segments and 25 foot gaps. Width tolerance shall be +/- 1/4 inch.

Temporary pavement marking lines, defined in Special Provision Section 652, Maintenance of Traffic, Temporary Centerline, will be applied as many times as necessary to properly delineate traffic lanes for the safe passage of traffic. Bi-directional delineators may be used in place of temporary lines, except where specified otherwise in Special Provision 652 Maintenance of Traffic, Temporary Centerline. Delineators will be applied at 40 foot intervals.

In overnight lane closure areas that are not to be overlaid, temporary plastic lines or raised pavement markers shall be used through the length of the taper.

Newly painted lines, markings and curb shall be protected from traffic by the use of cones, stationary vehicles or other approved methods until the paint is dry.

627.05 Preparation of Surface Immediately before applying the pavement marking paint to the pavement or curb, the surface shall be dry and entirely free from dirt, grease, oil, or other foreign matter.

Surface preparation for application of plastic markings shall conform to the manufacturer's recommendations.

627.06 Application Prior to applying paint for final pavement lines, the Contractor shall perform a test for paint thickness by furnishing and placing a piece of smooth, clean metal with an area of at least 144 in² in the path of the striping truck. The striping truck shall be passed over the piece of metal, painting the surface as it passes, without applying beads. The result of this test will be used to determine the pressure setting and speed of the truck when applying paint to obtain the specified thickness. Additional paint thickness testing may be required on the final paint markings. The wet thickness of paint without beads on final pavement lines shall be a minimum of 16 mils.

On other final pavement markings and on curb, where the paint is applied by hand painting or spraying, application shall be in two uniform covering coats, each at least 10 mils thick. Before the second coat of paint has dried, the glass beads shall be applied by a pressure system that will force the glass beads onto the undried paint as uniformly as possible.

Glass beads shall be applied to the final and temporary pavement lines, marking and curb at a sufficient rate and in sufficient quantity to assure complete and uniform coverage of hand painted surfaces and achieve proper reflectivity.

Permanent and temporary white lines and markings shall have a minimum final reflectivity value of 250 millicandelas per square meter per lux (mcd/m²/lux) and permanent and temporary yellow lines and markings shall have a minimum final reflectivity value of 150 millicandelas per square meter per lux (mcd/m²/lux), as measured by the Department. Measurements taken to determine reflectivity shall be done within 4 weeks after final placement.

If the final reflectivity values are less than the described minimums, the Contractor shall repaint those areas not meeting required reflectivity at no cost to the Department. If the final reflectivity values are less than the described minimums after the second attempt, the Contractor will submit in writing a plan of action to meet the reflectivity minimums prior to continuing any work. Once the plan has been reviewed and approved by the Department, the Contractor shall re apply at no cost to the Department.

Temporary painted lines and markings shall be applied as specified for permanent painted lines, except that the thickness shall be a minimum of 16 mils.

Temporary pliant polymer marking material shall be used for temporary markings on the final pavement and on pavements not to be resurfaced when such pavement markings do not conform to the final pavement markings pattern.

The plastic final pavement lines and markings shall be applied in accordance with the manufacturer's recommendations by the inlay method of application.

627.07 Establishment Period Inlaid plastic pavement lines and marking material furnished and installed under this contract for final pavement markings shall still be subject to a six-month period of establishment.

The period of establishment shall commence as soon as the plastic pavement lines and markings are complete and in place and shall continue for six months. At the end of the establishment period, a minimum of 95% of the plastic pavement lines and markings shall still be in place to be acceptable.

If less than 95% of the plastic pavement lines and markings are in place after six months, the Contractor shall replace all unsatisfactory plastic pavement lines and markings on the project without additional payment. Plastic pavement lines and markings designated for replacement shall be installed according to these specifications, unless otherwise directed. Plastic pavement lines and markings replaced at the end of the six month establishment period will not be subject to a further establishment period.

627.08 Removing Lines and Markings When it is necessary to remove pavement lines and markings, it shall be done by high pressure water, grinding or other approved acceptable means. The method chosen must be capable of completely eradicating the existing line or marking without excessive damage to the pavement. Burning and the use of solvents to remove temporary markings from final pavement or from existing pavement not to be resurfaced will not be permitted.

627.09 Method of Measurement The quantity of pavement marking lines identified in the contract as a plan quantity pay item, the measurement of payment will be the number of feet shown in the Schedule of Items. This quantity will be considered final and no adjustments will be made except when changes resulting in increases or decreases are made by the Resident.

The accepted quantity of temporary or permanent pavement marking lines when identified in the contract as a linear foot item shall be measured and paid for at the contract unit price per linear foot for the total amount applied and accepted.

Double yellow centerline, broken or solid, will be considered one line for measurement purposes. The measurement of broken lines will include the gaps when painted and will not include the gaps when plastic. Double Yellow Centerline, broken or solid shall not be paid through intersections or side roads and will be paid for the actual length of painted line.

Broken white lines will include the gaps when painted and will not include the gaps when plastic inlaid pavement lines are applied. Yellow or white solid edge lines and will not be paid through intersections or side roads and will be measured by the actual length of painted line.

Temporary pavement marking lines shall not be paid through intersections or side roads and will be measured per linear foot of actual length of painted and accepted.

Reflectorized curb will be measured or computed by the square foot of curb surface actually painted and reflectorized.

The accepted quantity of removing existing pavement markings will be measured by the square foot.

Temporary Bi-directional Yellow Delineators will be measured by each unit, complete in place, maintained, and accepted.

627.10 Basis of Payment The accepted quantity of pavement marking lines identified in the contract as a plan quantity pay item will be paid for at the contract unit price for plan quantity. No adjustment will be made to the quantity for payment, except as described 627.09 Method of Measurement

The quantity of permanent or temporary pavement marking lines identified in the contract paid by the linear foot will be measured for payment as described under section 627.09 Method of Measurement.

All other permanent pavement markings will be paid for at the contract unit price per square foot in accordance with 627.09 Method of Measurement.

If allowed by Special Provision, the Contractor may utilize Temporary Bi-Directional Yellow and White (as required) Delineators. When utilized, payment will be made as temporary pavement marking lines, measured and paid at the contract unit price per linear foot. Such payment will include as many applications as required and removal.

Payment for final plastic pavement lines and markings will be made in two parts. The first payment of 75% will be made when plastic pavement lines and markings are placed. The payment of the remaining 25% will be made at the end of the establishment period for all plastic line and pavement markings accepted.

The accepted quantity of any pavement marking lines will be paid for at the contract unit price and will include as many applications as required and removal when required.

The accepted quantity of Temporary Bi-directional Yellow Delineators will be paid for at the contract unit price.

Payment will be made under:

<u>Pay Item</u>	<u>Pay Unit</u>
627.18 12 inch Solid White Pavement Marking Line	Linear Foot
627.711 White or Yellow Pavement Marking Line - Plan Quantity	Linear Foot
627.733 4" White or Yellow Painted Pavement Marking Line	Linear Foot
627.744 6" White or Yellow Painted Pavement Marking Line	Linear Foot
627.75 White or Yellow Pavement & Curb Marking	Square Foot
627.77 Removing Existing Pavement Marking	Square Foot
627.78 Temporary 4" Painted Pavement Marking Line, White or Yellow	Linear Foot
627.781 Temporary 6" Painted Pavement Marking Line, White or Yellow	Linear Foot
627.407 Reflectorized Plastic, White or Yellow Pavement Marking	Square Foot
627.4071 Reflectorized Plastic, White or Yellow Pavement Marking Line - Plan Quantity	Linear Foot
627.811 Temporary Bi-directional Yellow Delineators	Each

SECTION 634 **HIGHWAY LIGHTING**

Revise this section by removing this section in its entirety and replace with the following:

634.01 Description This work shall consist of furnishing and installing a highway lighting system or modifying or removing an existing highway lighting system, including the design of

Light Standards, in accordance with these specifications and in reasonably close conformity with the plans.

634.02 General All material furnished by the Contractor shall be new unless otherwise specified. Substitutes for specified material may be accepted, upon approval of the Fabrication Engineer. Substitutes shall provide equal or better service. Where an existing system is to be modified, the existing material shall be removed, upgraded, or disposed of as shown on the plans or as directed.

All electrical equipment shall conform to NEMA, UL, or EIA standards, wherever applicable. In addition, all materials and workmanship shall conform to the requirements of the NEC, the local electrical Utility Company, and all local ordinances, which may apply.

634.021 Materials Materials shall meet the requirements specified in the following Section of Division 700 - Materials:

Steel Conduit	715.02
Non-metallic Conduit	715.03
Prewired Conduit	715.04
Metallic Junction and Fuse Box	715.05
Secondary Wiring	715.07
Luminaires, Lamps and Ballast	715.08
Luminaires, Lamp and Ballast for High Mast Lighting	715.09
Photo Electric Control	715.10
Service Equipment	715.11
Lowering System for High Mast Lighting	715.12
Aluminum Supports	720.01
Aluminum Mast Arm and Bracket Arm	720.02
Steel Supports	720.03
Steel Mast Arm and Bracket Arm	720.04
High Mast Light Standard	720.05
Steel H-beam Poles	720.06
Anchor Bolts	720.07
Wood Ornamental Light Standard	720.09
Wood Utility Pole	720.10
Mast Arm for Wood Utility Pole	720.11
Breakaway Devices	721.01

Transformer enclosures shall conform to NESC requirements. They shall be approximately 46 inches high, 42 inches wide and 42 inches deep. Dimensions should be verified with the electrical Utility Company before ordering. Clearances shall be provided as required by the NESC. The enclosure shall be painted inside and outside with one coat of red iron-oxide primer and a finish coat of gray baked enamel. Doors shall be furnished with padlock lugs.

The electric portable power unit shall be a heavy-duty reversing electric motor for the voltage and frequency shown on the plans and shall have a remote control.

The following are the minimum requirements for the high mast lighting lowering system:

- Ball bearing motor
- Grounded frame
- Torque limiter
- Power unit mounting frame
- Coupling to winch drive shaft
- Remote control unit with cable
- Cable with twist lock receptacle and plug for operator of power unit

All bolts for mounting lighting fixtures under bridge structures shall conform to the requirements of ASTM A307. These bolts and other fastening hardware shall be hot-dipped galvanized in accordance with ASTM A153.

Screened sand for bedding and covering direct buried cables shall meet the requirements of Section 703.14, except that there shall be 0-10% passing the No. 200 sieve.

634.022 Equipment List and Drawings Unless otherwise permitted in writing, the Contractor shall submit for review a list of equipment and materials which is proposed to be furnished. The list shall include the name of manufacturer, size, and identifying number of each item and other necessary data, including detailed scale drawings, wiring diagrams of special equipment and any proposed minor deviations from the plans. If requested, the Contractor shall submit sample articles of the material proposed for use. All of the above data except sample articles, shall be submitted in duplicate. Following checking, correction, and approval, not less than two complete sets of approved drawings shall be submitted. The Department will not be liable for material purchased, labor performed, or work delayed before such review. Where electrical equipment is to be constructed as shown on the plans, the submission of detailed drawings and diagrams will not be required.

Upon completion of the work, the Contractor shall submit three complete sets of corrected plans showing all construction changes.

634.023 Miscellaneous Material Insulating tape shall be of the self-bonding type. Jacket tape shall be of the water-resisting type. Friction tape shall be rubber-impregnated, woven cotton fabric.

634.024 Light Standards The terms "conventional standard" or "conventional light standard" shall mean the assembled metal base flange, transformer base or breakaway device, metal columnar shaft, metal overhanging bracket arm and incidental hardware.

The term "high mast pole" shall mean the assembled base plate flange, metal columnar shaft, luminaire tenon, mounting and lowering device and incidental hardware. For purposes of this specification, a structure shall be considered a high mast pole if the pole height, from base plate to the center of the luminaire, exceeds 55 feet.

The design, materials and fabrication of Light Standards shall meet the requirements of the current edition of AASHTO "LRFD Specifications for Structural Supports for Highway Signs, Luminaires, and Traffic Signals" and interims thereto, as noted below except as otherwise indicated within these specifications or on the plans.

Light Standards with a luminaire mounting height in excess of 55 feet (high mast pole) shall be designed using the following criteria:

- Basic wind speeds based on a 1700-year mean recurrence interval
- K_z as specified in Table C3.8.4-1 (Height and Exposure Factors)
- K_d as specified in Table 3.8.5-1 (Directionality Factors)
- G as 1.14, minimum (Gust Factor)
- C_d as specified in Table 3.8.7-1 (Wind Drag Coefficients)
- Fatigue Importance Category I with V_{mean} having a range of $9 \text{ mph} < V_{\text{mean}} \leq 11 \text{ mph}$.

Light Standards with a luminaire mounting height of 55 feet or less shall be designed using the following criteria:

- Basic wind speeds based on a 700-year mean recurrence interval
- K_z as specified in Table C3.8.4-1 (Height and Exposure Factors)
- K_d as specified in Table 3.8.5-1 (Directionality Factors)
- G as 1.14, minimum (Gust Factor)
- C_d as specified in Table 3.8.7-1 (Wind Drag Coefficients)
- Fatigue analysis is not required

For structural design purposes the luminaire mounting height for roadside installation is defined as the distance from the center of luminaire to the base plate bottom. For Light Standards mounted on structures and approaches to structures, the luminaire mounting height shall be defined and measured as the distance of the center of the luminaire to one of the following:

- a. For bridges over bodies of water Above the prevailing water level or, in the case of tidal waters, above mean high tide.

b. For overpass structures Above the lower roadway level.

c. For approach ramps Above the average adjacent ground level, if said ground level is more than 10 feet below the base of the light standard.

The design weight of luminaires shall be 60 pounds with an effective projected area of 2.5 ft², except that pole top-mounted luminaires shall have an effective projected area of 5.0 ft².

Light Standards mounted on a bridge structure or Light Standards fabricated with aluminum shall be equipped with an approved damping or energy-absorbing device.

Deflections of Light Standards and bracket arms shall be limited as follows:

a. Conventional Light Standards shall be able to support a 500 pound transverse load, applied at 18 inches below the pole top with a maximum deflection of 5% of the nominal pole length. A computer simulation or detailed computation using Service I load combination (as specified in the AASHTO LRFD Specification for Structural Supports for Highway Signs, Luminaires, and Traffic Signals) establishing a maximum of 7% deflection of the nominal pole length may be used as an alternate method.

b. Bracket arms shall be able to support a horizontal load, perpendicular to the axial vector of the arm, of 50 pounds and a concurrent vertical load of 100 pounds, both loads applied at the luminaire tenon, without developing a measurable permanent set.

c. High mast Light Standards shall have a maximum deflection of 7% of the nominal pole length under full design load when equipped with four luminaires.

Conformance to the above deflection criteria for Light Standards, bracket arms and high mast Light Standards shall be substantiated by detailed computations or computer simulation, accompanied by written methodology, or actual tests on materials produced for delivery under a Maine Department of Transportation contract.

The base plates of Light Standards shall have workable leveling nuts beneath and above them with flat washers against both nuts, when erected. The distance between the bottom of the base plate and top of the foundation shall not exceed twice the diameter of the anchor bolts. Grout, or other material, shall not be placed between the base plate and foundations.

Approval for deviations from the plans and/or specifications shall be requested in writing and shall be approved by the Fabrication Engineer before being incorporated in the manufacturer's drawings. Requests for substitution for all specified material shall be submitted in writing with full documentation (specifications, mill certifications, etc.) enabling the Department to evaluate the proposal.

A Certificate of Compliance shall be provided for all applicable materials noted in Section 634.021 – Materials, in accordance with the requirements of the General Statement of Division 700 Materials. Shop certification in accordance with Section 504.04 is required.

634.025 Conventional Light Standards After execution of the contract for conventional Light Standard(s), and before any shop work is commenced, the Contractor shall submit for approval the manufacturer's drawings of all standards and accessories proposed to be furnished and erected under this contract. The drawings shall be of sufficient detail to indicate material and/or dimensional conformance with these specifications and the plans. Each drawing shall contain a reference to the design criteria and certification that the design criteria have been met for the Light Standards, including bracket arms and associated hardware, fittings and breakaway devices, as submitted. A Professional Engineer licensed in accordance with the State of Maine regulations shall sign the certification under their official seal. The drawings shall use the same units as found in the project plans.

It is the intent of these specifications that the Contractor shall be fully responsible for the adequacy of the sizes, wall thickness, materials and connections of the Light Standards, including bracket arms and associated hardware, fittings and breakaway devices. Approval of the drawings will signify only approval of the material(s), mounting heights(s) and bracket arm length(s).

634.026 High Mast Light Standard For all high mast Light Standards, as defined in this Section, the Contractor shall submit for approval, in addition to the manufacturer's drawings, 3 sets of the design computations, including fatigue considerations consistent with AASHTO requirements. Approval of the drawings and computations will signify approval of all structurally significant details of the Light Standard and if any, the luminaire mounting and lowering device. All drawings and computations shall be signed by a Professional Engineer licensed in accordance with the State of Maine regulations. Approval will be based on the applicable provisions of Section 105.7.

The shaft shall be provided with an equipment access opening approximately 2 ft² and centered approximately 2 feet above the base. The access opening shall be reinforced to maintain the full design strength of the shaft and shall be provided with a hinged, removable, access door equipped with a vandal proof means of being locked in place. A positive means of internal grounding shall be provided inside of the access door.

All shaft sections shall be one plate thickness, except that a doubler plate may be used around the equipment access opening. The walls of polygonal shafts shall have an inside corner radius to wall thickness ratio not less than 2.

The Contractor may propose a galvanized and painted pole, in lieu of using weathering type steel. The steel shall be a base metal listed in the current edition of the AWS Structural Welding Code, D1.1. Paint color will be designated by the Fabrication Engineer. Galvanizing and surface preparation shall be in accordance with Section 504 and paint shall be a two-coat

system designed for use on galvanized surfaces approved by the Engineer. The Contractor shall supply sufficient additional coating material and instructions for touchup work.

634.027 Breakaway Supports Breakaway supports, approved by the Engineer, shall be supplied for use at all locations designated as breakaway. Breakaway Support Certification of both breakaway and structural adequacy shall be provided by the Manufacturer. Design calculations or test data of production samples to support certification shall be provided. Breakaway support components shall provide the same or greater structural strength than the support post or pole utilizing the breakaway device. Breakaway couplings shall not be used in conjunction with transformer bases. Breakaway devices must include a reaction plate connecting all anchor bolts under the breakaway device. Poles containing conductors must contain a fusible breakaway device disconnecting all ungrounded conductors simultaneously

Breakaway devices are subject to the applicable provisions of Section 721 - Breakaway Devices.

634.03 General The location of the roadway lighting systems and other incidental work will be shown on the plans. They are diagrammatic only, but shall be followed as closely as actual conditions at the site and the work of other Contractors will permit. As the work progresses, the drawings may be revised or supplemented by the Resident, and the Contractor shall perform the work required by such revisions or supplements without additional compensation, except as provided in Section 109.

Work shall be scheduled to assure that each highway lighting system shall be completed and ready for operation upon completion of the corresponding section of the roadway or as specified in Special Provision 107.

Before proceeding with any work under this Contract, the Contractor shall conduct continuity and insulating tests to establish the integrity of cable runs already in place. The Contractor shall report all cable faults to the Resident. In cases faults are located while contract work is in progress and the Contractor does not report them, the Contractor will be responsible for correcting those faults without extra compensation.

634.031 Foundations Foundations for Highway Lighting shall meet the requirements of Section 626 – Foundations, Conduit, and Junction Boxes for Highway Lighting, Traffic Signals, and Highway Lighting.

634.04 Cable Installation The Contractor shall pull all wires through conduits without overstressing or stretching any wire or scoring, cutting, twisting or damaging the protective covering or insulation. When pulling cable into conduits, if the strain on the cables is likely to prove excessive, the Contractor shall use soapstone powder or listed cable pulling lubricant as a lubricant. Where two or more cables are to occupy the same conduit, they shall be drawn in together and kept parallel to each other by the use of a pulling head. No aluminum wire shall be installed underground for primary and secondary wiring.

Both ends of each length of cable shall be sealed to prevent the entrance of moisture during shipment or during outdoor storage. Defective and damaged cable will be rejected and shall be replaced at no cost to the State.

Secondary wiring shall be installed as shown on the plans. Secondary wiring shall not be spliced underground. Splicing shall only occur in above ground hand holes and transformer bases. The wire for secondary circuits, which is pulled through ducts, shall be fed slack from the feed end. Secondary wiring being pulled through a junction box shall be provided with enough slack for the center of the cable to be positioned a minimum of one (1) foot outside the top of the junction box

Cables in junction boxes shall be provided with enough slack for the center of the cable to be positioned a minimum of one (1) foot outside the top of the junction box and shall be arranged as directed. After cables have been installed, the end of each section of cable in Light Standards and panel boxes shall be carefully sealed with DAC Heavy Duty KWIK Foam Polyurethane Sealant, Minimum Expanding or an approved equal. Sealant shall penetrate a minimum of four (4) inches into the conduit. All wiring shall be finished to provide a neat and orderly appearance. Ends of cable not connected to any device shall be insulated and sealed.

There will be no underground splicing of power conductors.

The trench for direct-buried cable shall be excavated to the width and depth shown on the plans or as directed.

Placement of the sand bedding shall be coordinated with the installation of the cables. After the cables and screened sand have been placed, the remainder of the trench shall be promptly backfilled with selected excavated material. Surplus material shall be disposed of as directed and the surface of the trench shall be loamed and seeded in accordance with Sections 615 and 618.

When connecting sockets, outlets and other similar equipment, the most accessible bare parts of each piece of equipment shall be connected to the grounded neutral. In order to ensure this has been done, each piece of equipment shall be tested after installation, under the supervision of the Resident, with a test lamp or other instrument, one leg of which has been connected to a definite ground, or by other approved means of testing.

All cables in junction boxes and Light Standards shall be tested for circuit connections, which shall be in conformity with those indicated on the plans. After verification of circuit connections, all cables in junction boxes, light standards and service panels shall be provided with individual metal tags, die-stamped with a phase designated A or B, as applicable. The tags shall be securely attached to the cables.

Splices to form continuous circuits shall be made by the Contractor and will only be permitted in accessible above ground locations. All other splices shall be made with approved crimp-type connectors.

Conductors shall not be pulled into conduit until pull boxes are set to grade, crushed rock sumps installed, grout placed around the conduit, concrete bottom of pull boxes placed and the metallic conduit bonded.

Where roadways are to remain open to traffic and existing lighting systems are to be modified, the existing lighting system shall remain in operation and the final connection to the modified circuit shall be made so that the modified circuit will be in operation by nightfall of the same day.

634.05 Erecting Light Standard To provide continuously aligned lamp post installations, Light Standards shall be located in accordance with the details governing the spacings and setbacks shown on the plans, unless otherwise directed.

The bracket arms shall be set normal to the edge of the roadway, unless otherwise directed. The bracket shall be assembled and attached to the shaft before the light standard is erected. If it is anticipated that there will be a period in excess of 24 hours between the erection of the Light Standards and the installation of the luminaires, the Contractor shall install a weight, weighing between 50 to 75 pounds, at the outboard end of each bracket arm. This weight shall be designed and fastened in such a way that it will not pose a hazard to persons or vehicles passing beneath it.

Light Standards shall be erected in a vertical position, with a maximum deviation from the vertical of ¼ inch in 5 feet, using either the leveling nuts provided with the anchor bolts or the breakaway couplings. Once the Light Standard is in its final position, the top nuts shall be tightened as follows:

a. Anchor Bolts with Breakaway Couplings The manufacturer's recommendation shall be used.

b. Anchor Bolts without Breakaway Couplings the nut shall be tightened to snug tight condition by utilizing the full effort of a worker using a standard spud wrench or comparable tool. After all nuts have been brought to a snug tight condition, each nut shall be tightened an additional 1/3 turn using an impact wrench, torque wrench or large crescent wrench.

A minimum of 2 bolt threads shall project beyond the outside face of the nut.

Nuts for bolts other than anchor bolts shall be tightened as outlined under b. above, for anchor bolts.

The bottom of all transformer bases shall be coated with a bitumen-mastic, epoxy paint.

When foundations and anchor bolts for Light Standards have been installed by others, the Contractor shall verify the anchor bolt dimensions at each location so that bases will be furnished with the proper bolt holes.

Wires in the shaft shall be supported with a Kellum-type, braided, strain-relief grip attached to a "J" hook mounted inside the shaft near the top.

Wood Ornamental Light Standards shall be installed as shown on the plans.

634.051 Removing Light Standards Before removing Light Standards, the luminaires shall be removed from the Light Standards and disposed of as noted on the plans.

Care shall be exercised in removing and transporting the Light Standards. The Contractor will be required to replace, at their expense, all equipment damaged or destroyed by their operations.

634.052 Portable Power Unit for Lowering Luminaires The number of portable electric power units with remote control required for operation of the high mast luminaire lowering system, will be 1 for every 10 high mast poles, or as shown on the plans.

634.06 Luminaires Luminaires shall not be installed until the lamp socket position has been inspected and approved for conformance with the manufacturer's recommended position for the specified distribution. All luminaires shall be adjusted to produce the maximum illumination on the roadway surface and shall be full IES cutoff.

The connections between the luminaires and connector kits shall be made with single conductor, number 12 wires AWG copper stranded THHN, minimum size. A 14 inch long Teflon sleeve shall be placed over each end of each conductor in the luminaire.

Installation of a connector kit, fused or non-fused, shall be in accordance with the manufacturer's instructions to provide watertight connections.

634.061 Under-Bridge Lighting Under-bridge lighting shall be installed in accordance with the plans and specifications, or as directed.

Circuits shall be fused in fuse boxes with 5-ampere cartridge-type, midget fuses, $\frac{3}{8}$ inch diameter and $1\frac{1}{2}$ inches long, unless otherwise indicated on the plans. Wiring connections in the under-bridge lighting units shall be made with 300°F wire.

All under bridge lighting, luminaires shall be installed and adjusted for maximum illumination of the roadway surface. The beam angle shall be adjusted as indicated on the plans.

In vehicular undercrossings, underpass lights shall be placed in operation as soon as practicable after falsework has been removed from the structure. Lighting for pedestrian structures shall be placed in operation before opening the structure to pedestrian traffic.

634.08 Service The Contractor shall install metal conduit riser with entrance cap, entrance switch, multiple control relay, and other equipment as shown on the plans.

The lighting system will be supplied with electrical power by the local power company. The type of service will be single phase, three wire, 240/480 volt or the voltage indicated on the plans, 60 hertz, alternating current. The meter trim will include a bypass handle to allow the power company to change the meter without disconnecting the power. An external, standalone breaker capable of shutting off the lighting control cabinet or signals will be provided to disconnect power to the control cabinet. No power shall be routed in or out of the control cabinet before this breaker. The power company will make all connections of the roadway lighting system cables at the power company's service pole. The Contractor shall notify the power company at least two weeks in advance of the time they intend to start construction at each of the sites and shall make all necessary arrangements with the power company for the required installation.

Roadway lighting cabinets shall be installed on stub poles with doors accessible from the roadway. All connections to equipment and terminals shall be neat and orderly conforming to the requirements specified.

Details for the fabrication and installation of service poles with cabinets and other equipment are shown on the plans.

Transformer enclosures used to protect overhead type transformers mounted on concrete pads shall be installed as shown on the plans. Transformers will be furnished by the power company.

All meter mounting devices shall be installed so that the meters will be upright (plumb). They shall be installed with the top of the meter not less than 48 inches nor more than 60 inches from the floor to the final grade. Exceptions to this height requirement will be made where special permission has been given to install group or modular metering, overall metering enclosures, or pole-mounted meters. Level grade shall be maintained for a minimum of 3 feet in front of the meter enclosure to provide a safe working space. In order to meet this requirement on uneven terrain, as an option, the Contractor may install a pressure-treated wood platform.

For any non-residential (industrial or commercial) self-contained meter socket the by-pass requirements are single phase, 100 or 150 amp, single handle lever operated.

The Contractor shall meet all requirements and regulations of Utility Companies when installing equipment on their poles and for the service connection. It is the responsibility of the Contractor to contact the appropriate Utility to determine their specific requirements.

634.081 Bonding and Grounding All metal conduit ends, Light Standards, luminaires, control cabinets, and exposed noncurrent carrying metal parts of fixed equipment shall be connected to the grounding conductor. All grounding and bonding shall conform to the current provisions of the NEC.

634.09 Testing Before acceptance of the work the Contractor shall cause the following tests to be made on all lighting circuits, by a licensed electrician. The tests do not need to be performed in the presence of the Resident, but the test results shall be recorded on the Highway Lighting Quality Control Check List and submitted to the Resident by the Contractor for acceptance. The form shall be signed by the licensed electrician certifying that the highway lighting meet the requirements of section 634.09.

a. Continuity Each circuit shall be tested for continuity.

b. Ground Each circuit shall be tested for grounds.

c. Resistance The resistance to ground on non-ground conductors shall be at least five megaohm at 60°F measured with a 1,000 volt megger. The ground resistance shall not be more than 25 ohms.

d. Voltage Voltage readings shall be made at each service pole, in the load contractor, with load and without load, and at each fixture with load.

e. Current Current readings shall be made on the load side of each load contractor phase and neutral. Readings shall be made at night with lighting systems in normal operation.

f. Test Data Electrical test data obtained from the above tests shall be furnished in writing.

g. Operational Test The Contractor shall conduct an operational test for the completed installation under normal operating conditions. This operational test shall have a duration of not less than two full days. The Resident shall be the sole authority to judge the adequacy of the length of the testing period in order to assure the satisfactory operation of the entire system or any of its sections. The work will not be accepted until the operational test has been successfully completed.

h. Functional Test With all equipment connected to the wiring system, a functional test shall be performed by the Contractor, in the presence of the Resident, to demonstrate that the system and all parts thereof function as specified. All defective materials or faulty installations shall be corrected by repairs or replacements by the Contractor to the satisfaction of the Resident at no additional cost.

Lighting circuits shall be subjected to such other tests as may be required and it shall be the responsibility of the Contractor to ascertain what tests are required and to perform these tests in the presence of the Resident. All tests shall be performed at the expense of the Contractor. Cost for power to conduct tests shall be paid by the Contractor.

634.091 Acceptance All systems shall be complete and in operation to the satisfaction of the Resident at the time of acceptance of the work.

The Contractor shall be responsible for the proper performance in service, in whole or in part, of the various lighting systems and all other electrical installations furnished and installed under this Contract and shall correct, at their own expense, all deficiencies in the operation which may arise prior to acceptance of the work. The Contractor shall be responsible for the cost of power until the work is accepted.

634.092 Method of Measurement Highway lighting system will be measured by the lump sum.

Light Standards will be measured by the single unit, complete in place and accepted.

The quantity of luminaires for high mast lighting will be measured by each single unit.

634.093 Basis of Payment The accepted quantity of Light Standards will be paid for at the contract unit price each for the number of units of the respective types. Payment shall be full compensation for the Light Standard and breakaway transformer base or breakaway device, bracket arm and all incidentals necessary to complete the work, including design of the Light Standards. Conduits, junction boxes, and foundations will be paid for under Section 626.

Payment for furnishing and installing luminaires for high mast lighting will be made for the accepted quantity at the contract unit price each, which shall include luminaire, ballast, lamp, and incidentals necessary to complete the work, including design of the high mast lighting.

The accepted highway lighting system will be paid for at the contract lump sum price for the complete lighting system shown on the plans, except that luminaires for high mast lighting and Light Standards will be paid for at the contract unit price each.

Lump sum payment for highway lighting system shall be full compensation for furnishing, installing and erecting: ballast, lamps, wiring in underground conduit, pole wiring, and all other wiring (except prewired conduit), transformer enclosures, luminaires (except luminaires for high mast lighting), break-away devices when applicable, all identification tags, and all materials, labor, equipment, tools, miscellaneous hardware and incidentals necessary to complete the work. Payment shall also include removing and resetting light standards, installing breakaway devices on existing poles, disposing of unused light standards, as noted on the plans, and for furnishing portable electric power units.

No separate payment will be made for bonding, grounding and ground rods; these costs shall be included in the contract price for conduit, light standards, service panels, or other items requiring bonding and grounding.

Trenching for direct buried cable will be incidental to highway lighting system and shall include excavating, furnishing and placing screened sand and backfilling.

Payment will be made under:

<u>Pay Item</u>		<u>Pay Unit</u>
634.160	Highway Lighting	Lump Sum
634.164	Luminaires for High Mast Lighting	Each
634.2041	Luminaires	Each
634.206	Light Standard for Post Top Luminaire	Each
634.207	High Mast Light Standard	Each
634.209	Wood Ornamental Light Standard	Each
634.210	Conventional Light Standard	Each

SECTION 639 ENGINEERING FACILITIES

Revise this section by removing this section in its entirety and replace with the following:

639.01 Description This work shall consist of providing, erecting, lighting, equipping and maintaining buildings to be solely used by the Resident and other assigned Department representatives as a field office. Upon completion of the work, the buildings and equipment shall remain the property of the Contractor.

639.02 Materials Materials for buildings shall be of good quality customarily used in standard frame house or office trailer construction.

639.03 General The building of the type called for shall be provided before the start of work, and shall remain until work is completed and accepted, unless earlier removal is authorized. The location shall be approved by the Resident and should be adjacent or virtually adjacent to the Project.

A fire extinguisher shall be provided in each building or office trailer for electrical and chemical fires and effective on all solvents used in the building.

Walls, roof, floor, windows, and doors shall be tightly constructed to the required area.

Furnishings shall be supplied as called for. Doors shall be equipped with locks and all keys shall be in the possession of the Resident. Windows shall be equipped with latches so they may

be locked on the inside. Window screens and screen doors shall be supplied when necessary. Adequate desk and desk space shall be provided. If a portable table is supplied, it should be adjustable to accommodate the various heights of employees. A 5-way adjustable office chair shall be provided in the quantities listed.

639.04 Field Offices Field Offices are designated Type A, Type B, or Type C. Buildings, including trailers, may be provided if they substantially equal or exceed the following requirements. Air conditioning, appropriate to the building size, shall be provided in all field offices.

The walls, roof, and floor of the building shall be completely insulated with a minimum insulation value of R-15. Office trailers shall be either new or in very good used condition. The interior walls shall be covered with suitable wall paneling. The entire office trailer shall be for the exclusive use of the Resident. The office trailer shall be winterized and completely enclosed at the bottom, if the trailer will be used in cold weather.

Other types of buildings and facilities may be furnished of equal or better quality. A public work area will be provided in the field office that shall be designed and constructed so that individuals with disabilities can approach, enter, and exit this area.

At least one accessible route to the field office shall be provided from accessible parking. The accessible route shall comply with the Americans with Disabilities Act Accessibility Guidelines (ADAAG) and this specification.

The minimum clear width of an accessible route shall be 36 inches except at doors. The least possible slope shall be used for an accessible route. An accessible route with a running slope greater than 1:20 shall be considered a ramp. Maximum ramp slope is 1:12. The maximum rise for any run of a ramp shall be 30 inches and the minimum clear width shall be 36 inches. Nowhere shall the cross slope of an accessible route exceed 1:50. Changes in level up to ¼ inch may be vertical and without edge treatment. Changes in level between ¼ inch and ½ inch shall be beveled with a slope no greater than 1:2. Ramp floor surfaces shall be stable, firm, and slip-resistant.

Ground floor surfaces along accessible routes and in accessible rooms and spaces including floors, walks, ramps, stairs, and curb ramps, shall be stable, firm, and slip-resistant.

The main door to the public work area shall have a minimum clear opening of 32 inches with the door opened 90 degrees, measured between the face of door and the opposite stop. Minimum maneuvering clearances at doors shall be provided. The floor or ground area within the required clearances shall be level and clear.

The handle and other operating devices on accessible doors shall have a shape that is easy to grasp with one hand and does not require tight grasping. Lever-operated mechanisms push type mechanisms, and U-shaped handles are acceptable designs. Hardware required for accessible door passage shall be mounted no higher than 48 inches above finished floor.

A minimum of 3 parking spaces will be supplied for Class B & C Field Offices and 6 for Class A. One wheelchair accessible parking space shall be located on the shortest accessible route of travel from adjacent parking to an accessible entrance.

Level landings shall be provided at bottom and top of each run. The landing shall be at least as wide as the ramp run leading to it with a minimum length of 60 inches.

If a ramp run has a rise greater than 6 inches or a horizontal projection greater than 72 inches, then it shall have handrails on both sides. Handrails shall have the following features:

- 1) Handrails shall be provided along both sides of ramp segments. The inside handrail on switchback ramps shall always be continuous.**
- 2) If handrails are not continuous, they shall extend at least 12 inches beyond the top and bottom of the ramp segment and shall be parallel with the floor or ground surface.**
- 4) The clear space between the handrail and the wall shall be 1½ inch.**
- 5) Gripping surfaces shall be continuous.**
- 6) Top of handrail gripping surfaces shall be mounted between 34 and 38 inches above ramp surfaces.**
- 6) Ends of handrails shall be either rounded or returned smoothly to floor, wall, or post.**
- 7) Handrails shall not rotate within their fittings.**
- 8) The diameter or width of the gripping surfaces of a handrail shall be 1¼ to 1½ inch, or the shape shall provide an equivalent gripping surface.**

Firm and sturdy steps shall also be provided with 7 inch maximum riser and 11 inch minimum depth, and at least one handrail extending from the top of the steps to a minimum 12 inches beyond the bottom of the steps.

The Contractor will make reasonable effort(s) to provide wheelchair accessible toilet facilities when "portable" facilities are provided.

The Contractor shall provide wheelchair accessible toilet facilities when flush type facilities, that is, those with running water, are provided; and the Contractor shall provide wheelchair accessible portable facilities, if used, when the contract duration exceeds two continuous construction seasons.

In addition to the facilities previously specified in this subsection, each field office shall meet the following minimum requirements:

<u>Description</u>	<u>Quantity</u>		
	<u>Type A</u>	<u>Type B</u>	<u>Type C</u>
Floor Area (Outside Dimension) - ft ²	312	220	125
Inside Wall Height – feet	7	7	7
Window Area - ft ²	55	35	35
Drafting Table Surface Area - ft ²	15	15	15
Drafting Stools - each	2	1	1
Office Desks - each	2	1	1
Ergonomic Swivel Chairs -ea (5-way adjustable)	3	2	2
Folding Chairs - each	3	2	2
Lighting Units - each	4	2	2
Electric Wall Outlets - each	6	4	3
Power Strip Surge Protectors - each	3	2	1
Wall Closets - each	1	1	1
Plan Rack for minimum of 6 sets of plans	1	1	0
Toilet Facility	1	1	1
Wastebaskets - each	2	2	1

All windows shall be provided with shades or blinds.

The toilet facility shall be for the exclusive use of State personnel. If requested, the Contractor will supply a lock to ensure exclusive use.

The Resident will have the option to reject any furniture or supplies provided to the field office based on general condition.

One hundred ten volt, 60 cycle, continuous electric service shall be supplied for lighting and 15 amp duplex wall outlets. Lighting shall consist of florescent light units with rapid start bulbs or LED shop style lights located over the work areas for a minimum of 50 foot candles overall. At least one external light source will be provided.

Drafting surfaces shall be 40 inches above the floor and have shelves beneath. Shelves for plans and rolls shall also be furnished overhead. Drafting stools shall be approximately 28 inches high.

Desks shall be single or double pedestal standard office type, and shall be in addition to “built-in” type desks in the office trailer.

Field offices shall be furnished with one four-drawer letter size metal filing cabinet.

Wall closets shall be 21 inches wide, 15 inches deep, and at least 4 feet high.

Each office shall be furnished with a broom, dustpan, sweeping compound, trash bags, and with cleaning material for cleaning glass. If the field office is carpeted, then a vacuum cleaner will be provided. The contractor will be responsible for disposing of trash from the field office.

The Contractor shall provide a fully functional wireless desktop copier/scanner/printer, capable of copying field books, for the Resident's use during the project. All maintenance and supplies, except paper, shall be the responsibility of the Contractor.

The Contractor shall provide bottled water and a microwave for the duration of the project. All maintenance and supplies shall be the responsibility of the Contractor. Alternate source of water, such as a water cooler, may be provided as approved by resident.

The Contractor shall provide a 4 cubic-foot refrigerator in the field office for the duration of the project.

Each office shall be furnished with a 10-person general-purpose first aid kit. The first aid kit shall be periodically inspected and refilled as necessary.

639.08 Heat Heat appropriate to the building size shall be supplied by the Contractor to maintain an acceptable room temperature during occupancy.

639.091 Broadband Connection The contractor will supply one computer broadband connection, modem lease and router. The router shall have wireless access and be 802.11n or newer capable. The type of connection supplied will be contingent upon the availability of services (i.e. DSL or Cable Broadband). It shall be the contractor's option to provide dynamic or static IP addresses through the service. The selected service will have a minimum download connection of 5.0 Mbps and 1.0 Mbps upload. The contractor shall be responsible for the installation charges and all reinstallation charges following suspended periods. Monthly service and maintenance charges shall be billed by the Internet Service Provider (ISP) directly to the contractor.

639.10 Method of Measurement Field office will be measured by the unit or lump sum for each building provided, equipped and maintained satisfactorily.

639.11 Basis of Payment The accepted quantity of field office will be paid for at the contract unit price each or lump sum which payment shall be full compensation for furnishing until contract completion, erecting, equipping, maintaining, furnishing electricity, heating, installing and maintaining toilet facilities and if necessary removing the buildings or office trailers.

Payment for these items will be made in 3 parts; the first payment of 1/2 to be made after the Contractor has supplied the building or office trailer and it has been approved. The remaining payments shall be made at intervals as follows:

A second payment of 1/4 shall be made when one-half of the anticipated work has been completed.

The final payment of the remaining 1/4 shall be made upon completion of the work.

Payment will be made under:

<u>Pay Item</u>	<u>Pay Unit</u>
639.18 Field Office, Type A	Each
639.19 Field Office, Type B	Each
639.20 Field Office, Type C	Each

SECTION 643
TRAFFIC SIGNALS

643.01 Description Revise this Section by removing in its entirety and replacing it with:

643.01 Description This work shall consist of furnishing and installing all equipment necessary for the erection and operation of a traffic signal, including traffic signal structures, flashing beacon, temporary traffic signal or modification of a traffic signal, all in reasonably close conformity with the plans.

643.02 General All equipment shall be new unless otherwise specified. Requests for substitution of any specified material shall be submitted in writing with all documentation (specifications, mill certifications, etc.) in order to enable the Department to evaluate the proposal. Substitutes for specified material may be accepted upon approval by the Fabrication Engineer. Functionally, any substitute shall give equal or better service than the specified material. Existing signal equipment to be used shall be cleaned, repainted, and reconditioned as noted on the plans. All equipment, installation of equipment and other incidental work shall conform to the latest applicable provisions of: NEC, MUTCD, NESC, NEMA, and the ITE Standards for traffic control equipment. All work shall be done to the satisfaction of the Resident. The meaning of specific terms shall be as defined in MUTCD, NESC, and the ITE Standards for traffic control equipment.

643.021 Materials Material shall meet the requirements specified in the following Sections of Division 700 - Materials:

Steel Conduit	715.02
Non-metallic Conduit	715.03
Prewired Conduit	715.04
Metallic Junction and Fuse Box	715.05
Secondary Wiring	715.07
Vehicular Signal Indications	718.01
Pedestrian Signal Indications	718.02
Signal Mounting	718.03
Vehicular Loop Detectors	718.04
Microwave Detectors	718.05
Pedestrian Detectors	718.06

Controllers	718.07
Controller Cabinet	718.08
Flasher	718.09
Program Selection	718.10
Contacts and Relays	718.11
Conductors	718.12
Aluminum Supports	720.01
Aluminum Mast Arm and Bracket Arm	720.02
Steel Supports	720.03
Steel Mast Arm and Bracket Arm	720.04
Anchor Bolts	720.07
Wood Utility Pole	720.10

643.022 Paint Aluminum paint shall conform to AASHTO M69, Type II. Green or yellow enamel paint, as indicated on the plans, shall meet or exceed the latest Federal Specification TT-E-489. The color shall match Federal Color Standard Number 14062.

643.023 Traffic Signal Structures The design, materials and fabrication of Traffic Signal Structures shall meet the requirements of the current edition of AASHTO “LRFD Specifications for Structural Supports for Highway Signs, Luminaires, and Traffic Signals” and interims thereto, as noted below except as otherwise indicated within these specifications or on the plans.

All poles and mast arms shall be designed using the following criteria:

- Basic wind speeds based on a 700-year mean recurrence interval
- K_z as specified in Table C3.8.4-1 (Height and Exposure Factors)
- K_d as specified in Table 3.8.5-1 (Directionality Factors)
- G as 1.14, minimum (Gust Factor)
- C_d as specified in Table 3.8.7-1 (Wind Drag Coefficients)
- Deflection requirements as specified in Section 10.4

Traffic signal support structures shall be classified as Fatigue Category III if they are located on roads with a speed limit of 35 mph or less, Fatigue Category II if they are located on roads with a speed limit of greater than 35 mph, and Fatigue Category I if noted on the Contract Plans. Fatigue Importance Factors shall be as specified in Table 11.6-1 (Fatigue Importance Factors).

All Traffic Signal Structures with mast or bracket arms shall be equipped with an approved damping or energy-absorbing device.

After execution of the contract and before any shop work is commenced, the Contractor shall submit for approval the manufacturer's drawings, including design computations and fatigue computations, of all Traffic Signal Structures proposed to be furnished and erected under this Contract. The drawings shall be of sufficient detail to indicate material and

dimensional conformance with these specifications and the plans. Each drawing shall contain a reference to the design criteria and a certification that the design criteria have been met for the Traffic Signal Structures, including poles, mast arms and associated hardware and fittings, as submitted. The certification shall be signed by a Professional Engineer licensed in accordance with State of Maine regulations under their official seal.

It is the intent of these specifications that the Contractor shall be fully responsible for the adequacy of the sizes, wall thicknesses, materials and connections of the Traffic Signal Structures, including poles, mast arms and associated hardware and fittings. Approval of the drawings by the Fabrication Engineer will signify only approval of the materials, mounting height(s) and mast arm length(s). Approval of deviations from the plans and/or specifications shall be requested in writing and approved by the Fabrication Engineer before being incorporated in the manufacturer's drawings.

The Contractor shall furnish and install all electrical fittings, pipe, switches, fuses, and such other material necessary to install the equipment properly and securely. All equipment shall conform to the applicable code and be of first-class workmanship. All electrical fittings shall be complete with weatherproof gaskets.

A Certificate of Compliance shall be provided for all applicable materials noted in Section 634.021 – Materials, in accordance with the requirements of the General Statement of Division 700 Materials. Shop certification in accordance with Section 504.04 is required.

643.024 Miscellaneous Materials Span wire shall be minimum $\frac{5}{16}$ inch diameter, minimum, 7 strand, extra-high strength, galvanized steel wire. Anchors shall be power installed and sized according to strain and soil conditions. All hardware, such as strand vise feed-thru dead ends, preforming guy grip dead ends and angle thimble-eye bolts, shall be standard pole line hardware.

Guying of poles shall meet the requirements of Grade "B" Construction as defined in the NESC. Guys shall be installed in line with the direction of pull. Anchors shall be power installed so that the centerline of the anchor rod will be within 10° of the line of the guy wire. The holding capacity of the anchor shall be 1.25 times the calculated load on the guy wire. Guy wires shall be utility grade and the maximum working stress shall not exceed half of the maximum ultimate tensile strength of utility grade guy strand. Where bedrock is encountered, rock anchors shall be used.

Pipe standoffs for sidewalk anchors shall be galvanized steel pipe sized according to the offset distance from anchor to pole and shall be fitted with standard guying hardware.

Messenger wire shall be $\frac{1}{4}$ inch diameter, 7 strand, extra-high strength, galvanized steel wire, unless otherwise specified.

LED lamps shall have a regulated power supply designed to electrically protect the diodes. The lamp shall be watertight and sealed to eliminate contaminants. The lamps shall be capable of operating at ambient air temperatures of -40°F to 140°F.

Lamp life shall be a minimum of 100,000 hours of continuous operation. They shall be manufactured using the Allen Gap Technology. Power consumption for 12 inch indications including power supply shall not exceed 20w.

643.03 General Installation details will be shown on the plans and/or specifications. The location shown for all equipment and vehicle detectors is approximate; final locations will be determined in the field.

During installation, all heads installed but not operating shall be covered or otherwise concealed from view.

The requirements of certain Sections of this specification may be waived for temporary traffic signals and traffic signal modifications, if so noted on the plans.

643.04 Poles Wood poles shall be placed in the ground to a depth of 20% of their overall length, with a maximum deviation from the vertical of ¼ inch in 5 feet.

After each wood pole has been set in the ground and plumbed, the space around the pole shall be backfilled with selected earth or sand, free of rocks and other deleterious material, placed in layers approximately 4 inches thick. Each layer shall be moistened and thoroughly compacted.

Traffic Signal Structures shall be erected in a vertical position, with a maximum deviation from the vertical of ¼ inch in 5 feet using the leveling nuts provided with the anchor bolts. Once the poles have been plumbed, the top nuts shall be tightened by bringing the nut to a snug tight condition using the full effort of a worker using a spud wrench or compatible tool. After all nuts have been brought to a snug, tight condition, each nut shall be tightened an additional one-third turn, using an impact wrench, torque wrench or large crescent wrench. A minimum of two full threads shall project beyond the outside face of the nut. Nuts and bolts, other than anchor bolts, shall also be tightened by the above procedure.

When foundations and anchor bolts have been installed by others, the Contractor shall verify the anchor bolt dimensions at each location so that bases will be furnished with properly located and sized bolt holes.

Wires in poles shall be supported with a Kellum-type, braided, strain-relief grip attached to a "J" hook mounted inside the pole near the top.

643.041 Foundations Foundations for Traffic Signal Structures shall meet the requirements of Section 626 – Foundations, Conduit, and Junction Boxes for Highway Lighting, Traffic Signals, and Highway Lighting.

643.05 Loop Detector and Loop Detector Wire Installation The detector unit shall be located in the controller. No more than four loops shall be connected to a single detector amplifier.

Detectors shall be installed according to the manufacturer's recommendation, subject to approval. Each detector shall be supplied complete with comprehensive installation instructions. The pavement slot for wire shall be 2 to 3 inches below the finished surface and not closer than 18 inches from the edge of pavement or the curb. The right-angle corners of the pavement slot shall be chamfered to eliminate sharp bends in the loop wires.

Loop detector wire shall be number 14 or number 12 AWG copper conductors drawn through vinyl plastic tubing approximately ¼ inch in diameter. All pulse loop "approach" wiring shall be insulated red and shall be permanently marked "A", "B", "C", or "D", according to the "approach" guidelines in the controller cabinet. All pulse loop "presence" wiring shall be insulated black and shall be permanently marked according to the "presence" guidelines in the controller cabinet. All loop lead-ins shall be of the same conductor with no splicing. The lead-in from the amplifier to the beginning of the loop shall be shielded pairs, as shown on the plans.

All debris and moisture shall be removed from the loop pavement slot before installation of loop wires. The pavement slot shall be filled to the road surface with an approved sealing compound to form a waterproof bond with the pavement after installing the wire loop.

Detector conductors shall not be housed in the same jacket as the signal conductors.

643.06 Microwave Detector Installation The microwave detector shall be installed in accordance with the manufacturer's recommendations. A four-conductor wire shall be installed from the microwave unit to the controller. All angles and adjustment of patterns shall be the responsibility of the Contractor. The detectors shall operate in either pulse or presence mode.

643.07 Span Wire, Messenger Wire, and Guy Wire All span wire, messenger wire, and guy wire installations shall be in conformance with the requirements of the Utility Companies, when installed on Utility Facilities.

All span wire hanging traffic signals permanent or temporary will have a bottom tether wire to prevent the signal from excessive swinging

All span wires, messenger wires, guy wires, terminal boxes, controller cabinets, or any other metallic surface that might be contacted by people, shall be bonded to ground.

All sidewalk guy wires and slant guy wires installed in a sidewalk area shall be equipped with full-round or half-round guy guards.

643.08 Conduit All conductors under roadways from the controller to the mast arm poles shall be 3 inch schedule 80 PVC.

643.09 Service Connection The Contractor shall furnish and install the necessary electrical service as directed by the Utility Company. The Contractor shall make all arrangements for the service connection and be responsible for all charges incurred thereby.

Under no condition shall any equipment, except that shown on the plans, be installed on any Utility Facilities.

Traffic signal services shall have an automatic transfer switch such as a GENERLINK model MA23/24 – S installed, this will be required on traffic signals only not beacons or dynamic signs.

Whenever a service connection is to be made, the Contractor shall contact the Utility Company involved and inform them of the location, pole number, and time proposed for the service connection.

The traffic cabinet shall be marked with:

- An appropriate arc flash plaque or decal with the following information
- Flash hazard boundary
- Cal/cm² hazard at 18 inches
- PPE level
- Shock hazard when cover is off
- Limited approach boundary
- Restricted approach boundary
- The prohibited approach boundary

This shall be located on the outside of the equipment and shall be visible, weatherproof, and fade resistant, and not easily removed.

The Contractor shall be responsible for all outstanding bills for preliminary work done by the Utility Company during the installation of the traffic signal system, to facilitate the service connection.

A service ground rod shall be installed if the service meter trim is not grounded.

The Contractor shall be responsible for grounding the system to 5 OHMS or less. The grounding shall be performed using a ground meter with reference grounds. All testing will be done in the presence of the Resident.

All meter mounting devices shall be installed so that the meters will be upright (plumb). They shall be installed with the top of the meter not less than 48 inches nor more than 60 inches from the floor to the final grade. Exceptions to this height requirement will be made

where special permission has been given to install group or modular metering, overall metering enclosures, or pole-mounted meters. Level grade shall be maintained for a minimum of 3 feet in front of the meter enclosure to provide a safe working space. In order to meet this requirement on uneven terrain, as an option, the Contractor may install a pressure-treated wood platform.

For any non-residential (industrial or commercial) self-contained meter socket the by-pass requirements are single phase, 100 or 150 amp, single handle lever operated.

The Contractor shall meet all requirements and regulations of Utility Companies when installing equipment on their poles and for the service connection. It is the responsibility of the Contractor to contact the appropriate Utility to determine their specific requirements.

643.10 Wiring The Contractor shall furnish and install sufficient cable and wire to operate the system properly as shown on the plans and as directed.

The following color code shall be used where possible:

Red Wire	Red, artery
Orange Wire	Yellow, artery
Green Wire	Red, side street
Orange with Tracer	Yellow, side street
Green with Tracer	Green, side street
White and white with tracer	Common for all signals and bond
Blue	All steady burning arrows
Blue with Tracer	Intermittent arrows
Remaining	Detectors and pedestrian signals

The white wire and white wire with tracer shall be used for all common connections and it shall be continuously connected to ground at the controller.

There shall be no wire splices. Connections shall be made on a terminal board inside a watertight galvanized steel or aluminum junction box or in an aerial terminal enclosure with protective cover rated for 600 volts.

Spade type copper terminal ends shall be used to attach all conductors to terminals. All exposed metal parts, including service conduit and the controller cabinet shall be bonded and grounded.

Not more than 3 conductors shall be brought to any one terminal. Terminals shall be mounted to face the cabinet door.

The number and size of conductors required in each cable will be indicated on the plans.

643.11 Vertical Clearance Unless otherwise specified on the plans and/or specifications, vertical clearances for vehicular and pedestrian heads shall be in conformity with the MUTCD. All clearances shall be uniform among each type of head or mounting scheme. Clearance for span wire mounted flashing beacon heads shall be a minimum of 17 feet and a maximum of 18 feet.

643.12 Painting Unless otherwise indicated, all exterior parts of the following equipment shall be delivered to the project finished with green or yellow enamel:

**Vehicular Signal Heads
Pedestrian Signal Heads
Pedestrian Push Button Detectors**

The outside of the steel controller cabinet shall be painted with aluminum paint.

The Contractor shall apply one coat of green enamel to all existing equipment designated on the plans to be painted. The Contractor shall touch up all scratches on exposed surfaces of new equipment with matching enamel after the equipment has been installed.

All exposed signal parts to be painted shall be cleaned and shall be dry when the paint is applied. No painting shall be done in damp weather nor when the air temperature is below 40°F, unless otherwise permitted.

The Contractor shall identify recently painted equipment with "Wet Paint" signs, and shall be responsible for all claims for damages resulting from contact with wet paint surfaces.

643.13 Power Factor In the event that the equipment is of such design that the power factor is reduced below the requirement of the Utility Company, the Contractor shall furnish and install, without further charge, all equipment necessary to restore the power factor to a satisfactory percentage. Such equipment shall be accessible and shall not be mounted on the Utility Facilities.

643.14 Field Tests Before acceptance of the work, the Contractor shall conduct the following tests on all traffic signal equipment and circuits, by a licensed electrician. The tests do not need to be performed in the presence of the Resident, but the test results shall be recorded on the Traffic Signal Quality Control Check List and submitted to the Resident by the Contractor for acceptance. The form shall be signed by the licensed electrician certifying that the signal equipment and circuits meet the requirements of section 634.14.

a. Continuity Each circuit shall be tested for continuity.

b. Ground Each circuit shall be tested for grounds.

c. Megger Megger tests at 500 volts DC shall be made on each circuit between the circuit and a ground. The insulation resistance shall not be less than 10 megaohms on

all circuits, except for inductive loop detector circuits, which shall have an insulation resistance value of not less than 100 megaohms.

d. Loop Inductance A loop test meter shall be used to determine that the inductance of the installed loop and lead-in are within the tuning range recommended by the loop detector manufacturer.

e. Functional A functional test shall be made in which it is demonstrated that each part of the system functions as specified.

The functional test for each new or modified traffic signal and flashing beacon shall consist of not less than 10 days of continuous satisfactory operation. If unsatisfactory performance of the system develops, the condition shall be corrected and the test shall be repeated until the 10 days of continuous satisfactory operation is obtained.

The initial operation shall be made between 9:00 A.M. and 2:00 P.M. unless specified otherwise. Before initial operation, all equipment shown on the plans shall be installed and operable.

Initial operation of new or modified traffic signal systems shall be made only after all traffic signal circuits have been thoroughly tested as specified above.

During the test period all costs except electrical energy shall be the Contractor's responsibility.

Functional tests shall start on any working day except Monday, Friday, Saturday, Sunday or the day preceding a legal holiday.

Shutdown caused by a power interruption shall not constitute discontinuity of the functional test, however, the test shall continue after power is restored.

643.15 Timing The controller shall be timed as noted on the plans. The Contractor shall notify the Resident, at least 1 week in advance, of their intention to initially operate the signals.

At the time of initial operation of the new signals, the Contractor shall provide police protection from the local police department at the Contractor's expense until the Contractor demonstrates to the Resident that the signal operates in conformance with this specification.

643.16 Final Cleaning Up After all work has been completed, the Contractor shall remove all barriers, "Wet Paint" signs, equipment and all debris which has accumulated during the work.

Unless otherwise specified in the plans, the Contractor shall remove and deliver all unused signal equipment and wiring to the State of Maine, Department of Transportation, as directed by the Resident. The Contractor shall notify the State Traffic Engineer (207-624-3620) as to

time and date of such delivery. (Deliveries will be accepted Monday through Friday between the hours of 7:00 A.M. and 4:00 P.M. only.) Notification shall precede delivery by a minimum of 24 hours.

643.17 Documents The Contractor shall furnish two operation and maintenance manuals for all controller units, auxiliary equipment, vehicle detector sensor units, control units, and amplifiers. Documents shall be delivered with the controller at the time of testing. Each manual must include, but need not be limited to the following:

- a. An explanation of the theory of operation, including a functional description and a detailed circuit description.
- b. A schematic diagram of each unit. A cabinet wiring diagram including all field wiring and pin locations and designations for all plug type connectors. If any circuit changes are made in the field, the changes shall be noted on the schematic diagrams.
- c. A trouble shooting and preventive maintenance procedure including both field and bench trouble shooting analysis.
- d. A parts list including a pictorial diagram showing the location and identification of each component on the chassis or circuit board.
- e. A drawing of the controller cabinet interior showing the location of all shelves, terminal blocks, relays, timers, loop amplifiers.

In addition, manufacturer's warranties and guarantees for materials shall be delivered to the Resident before acceptance of the project.

643.18 Method of Measurement Traffic signals, traffic signal modifications, interconnect wire, video detection system, traffic signal control system, and flashing beacons will each be measured for payment by the lump sum in place. Temporary traffic signals will be measured for payment by the lump sum, satisfactorily installed, operated, and removed.

Pedestal poles, strain poles, combination poles, and mast arm poles with mast arms will be measured by each unit.

Each loop detector installed, connected to appropriate phases in the controller cabinet, complete and operational will be measured by the unit.

Excavation in solid ledge rock for replacement of wood poles will be measured by the cubic yard. The depth of measurement will be to the bottom of the pole, and the diameter of measurement will be the pole diameter plus 30 inches.

643.19 Basis of Payment Traffic signal modifications, traffic signals, interconnect wire and flashing beacons will be paid for at the contract lump sum price, which payment will be full

compensation for furnishing and installing all materials, both new and reused, including, but not limited to wood poles, span wire, tether wires, backplates, visors, guys, controllers, vehicular heads, pedestrian heads, flashing beacons, wiring, cable, pole risers, LED lamps, and all appurtenances and incidentals, including design of the Traffic Signal Structures, required for a complete functioning installation and for furnishing all tools and labor necessary for completing the installation. Conduits, junction boxes, and foundations will be paid for under Section 626.

Pedestal poles, strain poles, combination poles and mast arm poles with mast arms will be paid for at the contract unit price each which payment shall be full compensation for furnishing and installing all materials, tools and labor necessary to erect the poles.

Payment for temporary traffic signals shall include compensation for the removal of the system upon completion of the work. All materials used for temporary traffic signals will remain the property of the Contractor. Operating the controller by hand will be paid for under Section 629.

Payment will be made for each Loop Detector at contract price, which will be full compensation for materials, labor, and equipment for each loop installed and fully operational.

Traffic signal control system will be paid for at the contract lump sum price, which payment will be full compensation for furnishing and installing all materials, including, but not limited to local intersection traffic signal controller, controller cabinets, on-street master controller, supervisory PC software, and all appurtenances and incidentals required for a complete functioning installation.

Video detection system will be paid for at the contract lump sum price, which payment will be full compensation for furnishing and installing all materials, including, but not limited to video processing unit, video cameras, supervisory PC software, and all appurtenances and incidentals required for a complete functioning installation.

Payment for excavation of solid bedrock for the placement of wood poles will be made under Item 206.07.

Payment will be made under:

<u>Pay Item</u>	<u>Pay Unit</u>
643.60 Flashing Beacon at:	Lump Sum
643.71 Traffic Signal Modification:	Lump Sum
643.72 Temporary Traffic Signal:	Lump Sum
643.80 Traffic Signals at: __	Lump Sum
643.81 Traffic Signal Control System	Lump Sum
643.83 Video Detection System	Lump Sum
643.86 Traffic Signal Loop Detector	Each

643.90	Interconnect Wire Between:	Lump Sum
643.91	Mast Arm Pole	Each
643.92	Pedestal Pole	Each
643.93	Strain Pole	Each
643.94	Dual Purpose Pole	Each

SECTION 645
HIGHWAY SIGNING

Revise this section by removing this section in its entirety and replace with the following:

645.01 Description This work shall consist of designing, furnishing and installing new signs, sign supports, delineators, Polyvinylchloride (PVC) Pipe and breakaway devices and removing, relocating and/or modifying existing signs and sign supports, in accordance with these specifications and in reasonably close conformity with the Contract Plans.

645.02 General All equipment shall be new unless otherwise specified. Requests for substitution of any specified material shall be submitted in writing with all documentation (specifications, mill certifications, etc.) in order to enable the Department to evaluate the proposal. Substitutes for specified material may be accepted, upon approval of the Fabrication Engineer. Substitutes shall give equal or better service than the specified material. Where an existing system is to be modified, the existing material shall be removed, upgraded, or disposed of as directed by the contract documents.

645.021 Materials Materials shall meet the requirements specified in the following Sections of Division 700 - Materials:

Polyvinylchloride (PVC) Pipe	706.08
Reflective Sheeting	719.01
Demountable High Intensity Reflectorized Letters, Numerals, Symbols and Borders	719.02
Aluminum Extrusions	719.03
Aluminum Sheets	719.04
Plywood	719.05
Demountable Reflectorized Delineators	719.06
Assembly Hardware	719.07
Aluminum Supports	720.01
Steel Supports	720.03
Steel H-beam Poles	720.06
Anchor Bolts	720.07
U-Channel Posts	720.08
Wood Sign Posts	720.12

Paint for the edge and back of plywood and field coat paint for wood sign posts shall be an exterior grade dark green enamel conforming to Federal Specifications TT-P-71b.

Materials shall meet the gradation requirements only of the following:

Aggregate for Untreated Surface Course and Leveling Course	703.10
Underdrain Backfill Material	703.22

645.022 Sign Layout Drawings The Contractor shall submit 3 sets of sign-face, layout-detail, and scale drawings. Fabrication of the signs shall not begin until the Contractor has received approval of these drawings. The drawings shall contain complete detailed information and dimensions. One set of drawings will be returned to the Contractor, who will submit corrected drawings, if required. The drawings shall be detailed using the same units used on the Contract Plans.

645.023 Sign Support Structures The design, materials and fabrication of Sign Support Structures shall meet the requirements of the current edition of AASHTO “LRFD Specifications for Structural Supports for Highway Signs, Luminaires, and Traffic Signals” and interims thereto, as noted below except as otherwise indicated within these specifications or on the Contract Plans.

Beam-mounted roadside sign supports and associated signs and hardware shall be designed using the following criteria:

- Basic wind speeds based on a 300-year mean recurrence interval
- K_z as specified in Table C3.8.4-1 (Height and Exposure Factors)
- K_d as specified in Table 3.8.5-1 (Directionality Factors)
- G as 1.14, minimum (Gust Factor)
- C_d as specified in Table 3.8.7-1 (Wind Drag Coefficients)

Bridge-mounted, bridge-type, cantilever, and butterfly-type sign supports and associated signs and hardware and all sign support structures supporting variable message signs shall be designed using the following criteria:

- Basic wind speeds based on a 1700-year mean recurrence interval
- K_z as specified in Table C3.8.4-1 (Height and Exposure Factors)
- K_d as specified in Table 3.8.5-1 (Directionality Factors)
- G as 1.14, minimum (Gust Factor)
- C_d as specified in Table 3.8.7-1 (Wind Drag Coefficients)
- Deflection requirements as specified in Section 10.4

Cantilever and butterfly-type sign supports and all structures supporting variable message signs shall be classified as Fatigue Category I. Bridge-type sign supports shall be classified as Fatigue Category II. Fatigue Importance Factors shall be as specified in Table 11.6-1 (Fatigue Importance Factors).

For bridge-mounted sign supports (including approaches to bridge structures), the mounting height shall be measured as the distance of the mounted sign(s) center of gravity to one of the following:

For bridges over bodies of water: above the prevailing water level or, in the case of tidal waters, above mean high tide.

For overpass structures: above the lower roadway level.

For approach ramps: above the average adjacent ground level, if said ground level is more than 10 feet below the base of the structure.

All cantilever and butterfly type sign support structures shall be equipped with an approved damping or energy-absorbing device.

For aluminum construction, welding shall conform to the current edition of AWS Structural Welding Code, Aluminum, D1.2 for aluminum construction.

After execution of the contract and before any shop work has commenced, the Contractor shall submit for approval the drawings, and design and fatigue computations if prescribed below, for all Sign Support Structures proposed to be furnished and erected under this contract. The drawings shall be of sufficient detail to indicate material and/or dimensional conformance with these specifications and the Contract Plans and, in the case of bridge, cantilever and butterfly type sign supports, shall be sufficiently detailed to show all significant structural details.

Approval for deviations from the Contract Plans and/or Specifications shall be requested in writing and shall be approved by the Fabrication Engineer before being incorporated in the manufacturer's drawings. Requests for substitution of all specified material shall be submitted in writing, with full documentation (specifications, mill certification, etc.) enabling the Department to evaluate the proposal.

Sign Support Structures and anchor bolts shall meet the requirements specified in Section 720 as well as the current edition of AASHTO "LRFD Specifications for Structural Supports for Highway Signs, Luminaires, and Traffic Signals" and interims thereto.

A Certificate of Compliance shall be provided for all applicable materials noted in Section 645.021 – Materials, in accordance with the requirements of the General Statement of Division 700 - Materials.

a. Beam-Mounted Roadside Signs The beams for beam-mounted roadside signs shall be of the size, material and shape designated in the Contract Documents. The Contractor shall be fully responsible for the adequacy and design of any structural details not shown on the Contract Plans, and each drawing shall contain a reference to the design criteria. A Professional Engineer licensed in accordance with the State of

Maine regulations shall sign the certification under their official seal that said design criteria have been met by all parts of the structure designed and/or detailed by the Contractor. Approval of the drawings will signify only approval of the size, material and length of the beam.

b. Bridge-Mounted Sign Supports Bridge-mounted sign supports shall be constructed to the configuration and sizes and of the material shown on the Contract Documents. Approval will be based on the applicable provisions of Section 105.7 - Working Drawings. Fastening sign panels directly to steel or aluminum members shall be as described in Section 719.07, as well as other applicable Sections, Plans and Specifications.

c. Bridge-Type, Cantilever, and Butterfly-Type Sign Supports The Contractor shall be responsible for the design of the Sign Support Structures for bridge-type, cantilever and butterfly-type sign supports in accordance with this specification.

Signs shall be placed on the Sign Support Structure such that the bottom edges are aligned (unless written consent from the Fabrication Engineer is obtained), while accommodating the minimum height requirement - see Section 645.06. The Contractor shall use the Contract Plans in order to determine the approximate horizontal placement of signs. Installation shall be in accordance with Section 645.06 - Installation of Type I Signs. The structure and foundation shall be designed to accommodate an additional theoretical sign load on each structure. This additional theoretical sign load for each sign shown in the contract documents shall be computed by: For single signs increasing the sign widths an additional 25% without changing the horizontal midpoint of the sign; for multiple signs the sign widths shall be increased 25% toward the outside sign edges. The height of all signs shall be increased 25% without changing the bottom edge elevation of the signs.

Bridge-type Sign Support Structures shall be designed using either a tri-chord or four-chord truss structure as the overhead member. Each of the two upright members supporting the bridge-type overhead truss member shall consist of a minimum of two vertical legs. A four chord truss configuration shall be required if the Contract Documents specify placing signs on both sides of the overhead structure (two way traffic beneath structure). Cantilever and butterfly-type structures shall be designed using either a tri-chord or four-chord overhead truss member. The upright member of a cantilever or butterfly-type support structure shall have a maximum horizontal deflection in accordance with Section 10.4.2.1 of the current edition of the AASHTO "LRFD Specifications for Structural Supports for Highway Signs, Luminaires, and Traffic Signals", and interims thereto.

The base plates of uprights for all types of Sign Support Structures shall have heavy hex leveling nut with 2 hardened flat washers. The distance between the bottom of the base plates to the top of the foundations shall not exceed twice the diameter of the

anchor bolts. Grout, or other materials, shall not be placed between base plates and the top of foundations.

In addition to the required detail drawings, the Contractor shall submit 3 copies of the design and fatigue computations meeting the all applicable requirements of this specification or the Contract Plans for each Sign Support Structure. Erection lifting points shall be clearly depicted on the shop drawing. The computations shall be sufficiently detailed to allow the Engineer to review the computations. Computer printouts will not be accepted unless they meet the above criteria. All plans and design calculations for sign support structures and foundations shall be sealed by a Professional Engineer licensed in accordance with the State of Maine regulations. Approval will be based on the applicable provisions of Section 105.7 - Working Drawings.

Overhead sign panel mounting devices shall be designed accommodating the requirements of appropriate sign panel tilting included in this specification. The design of this assembly shall include fastening sign panels directly to steel or aluminum members as further described in Section 719.07, as well as other applicable Sections, Plans and Specifications.

d. Breakaway Supports for Sign Supports Breakaway supports for sign supports will be required only for those locations indicated on the Contract Plans. Breakaway supports, approved by the Resident, using load-concentrating couplings shall be supplied for use at all locations designated as breakaway. Breakaway Support Certification of both breakaway and structural adequacy shall be provided by the Manufacturer. Design calculations or test data of production samples to support certification shall be provided. Breakaway support components shall provide the same or greater structural strength as the support post or pole utilizing the breakaway device. On multi-pole sign supports designated as breakaway, each pole shall be equipped with breakaway hinges immediately below the lower edge of the sign. Hinges relying on the friction between the hinge and the pole face for transmitting the design moment will not be accepted for use. Breakaway devices are subject to the applicable provisions of Section 721.

645.024 Bridge, Cantilever and Butterfly Support Structure Foundations Foundations for Highway Signing structures shall meet the requirements of Section 626 – Foundations, Conduit, and Junction Boxes for Highway Lighting, Traffic Signals, and Highway Lighting.

645.03 Classification of Signs Sign sizes, color and legend designs shall conform to these specifications, the Contract Plans, and MUTCD requirements. The signs are classified according to the intended use as follows:

a. Sign Type I guide signs shall consist of high intensity prismatic, reflectorized sheeting or reflectorized, demountable letters, numerals, symbols and border mounted

on a high intensity prismatic, reflective sheeting background adhered to a sign panel constructed of extruded aluminum planks.

b. Sign Type I regulatory, warning, and route marker assembly signs shall consist of high intensity prismatic, reflective sheeting letters, numerals, symbols, and border on a high intensity prismatic, reflective sheeting background adhered to a sign panel constructed of sheet aluminum.

c. Sign Type II guide signs shall consist of high intensity prismatic, reflective sheeting letters, numerals, symbols and border on a high intensity prismatic, reflective sheeting background attached to a sign panel constructed of plywood.

d. Sign Type II regulatory, warning and route marker assembly signs shall consist of high intensity prismatic reflective sheeting letters, numerals, symbols and border on a high intensity prismatic reflective sheeting background adhered to a sign panel constructed of sheet aluminum or plywood.

645.04 Fabrication of Type I Guide Signs

a. Panels The panels for this type sign shall be shop-fabricated from aluminum planks to the sizes designated on the approved shop drawings. Cut edges shall be true, smooth, and free from burrs or ragged breaks. Flame cutting will not be permitted. Bolt holes may be drilled to finished size or punched to finished size, provided the diameter of the punched hole is at least twice the thickness of the metal being punched.

Fabrication of extruded aluminum sign planks, including punching or drilling holes and cutting to length, shall be completed before the metal degreasing and the application of the reflective sheeting. The bolts required for fastening the extruded aluminum planks together shall conform to the designs used in standard commercial processes for the type of extruded aluminum panels to be used as approved.

All route shields shall be on an overlay aluminum sheet of 0.080 inch minimum thickness and shall be in full color with reflective background; they shall not have demountable numerals and borders.

b. Reflective Sheeting The high intensity prismatic reflective sheeting shall be applied to the extruded aluminum plank in accordance with the current recommendations of the sheeting Manufacturer.

The reflective sheeting shall cover the complete panel and shall not be trimmed to conform to the border. The reflective sheeting shall overlap into the side recess of the individual planks. There shall be no paint applied to the sign panels. The surface of all completed sign panels shall be flat and free of defects. Extruded aluminum molding shall be placed on the edges of the extruded panels, as shown on the Contract Plans.

c. Text The design of upper and lower case letters, numerals and symbols, and the arrangement and spacing of texts shall be as provided on the Contract Plans and in conformance with the MUTCD and Standard Highway Signs.

Text for Guide Signs shall be composed of demountable letters, numerals, symbols, and borders and shall be high-intensity prismatic, reflective sheeting. The demountable text shall be applied to the panels by use of aluminum pop rivets, in accordance with standard commercial processes, as approved. All demountable letters, numerals, symbols, and borders shall be the same manufacturer's make for the entire project. Cutout high-intensity, reflective sheeting text shall be applied to the sign panel with a pre-coated, adhesive backing.

645.041 Fabrication of Type I Regulatory, Warning and Route Marker Assembly Signs and Type II Sheet Aluminum Regulatory, Warning and Route Marker Assembly Signs

a. Panels Sheet aluminum sign panels shall be shop-fabricated to the size shown on the Contract Plans. The corners shall be rounded to the indicated radius where shown.

Bolt holes may be drilled or punched to finished size provided the diameter of the punched hole is at least twice the thickness of the metal being punched. Cut edges shall be true, smooth, and free from burrs or ragged breaks. Flame cutting will not be permitted. Punching or drilling of holes and cutting to size shall be completed before metal degreasing and the application of reflective sheeting.

b. Reflective Sheeting The high intensity prismatic reflective sheeting shall be applied to the sheet aluminum sign panels in accordance with the current recommendations of the sheeting Manufacturer. The reflective sheeting colors shall conform to the MUTCD Standard Highway Sign colors for each type of sign. Surface of all panels shall be flat and free from defects.

c. Text The text for regulatory, warning, confirmation and route marker assembly signs shall be composed of: High intensity prismatic, reflective sheeting letters, numerals, symbols and borders; or the silver letters may be formed by applying transparent ink to the reflective sheeting background where the silk screen process is used; or other methods to form the text may be used, when approved in advance.

645.042 Fabrication of Type II Guide Signs and Type II Plywood, Regulatory, Warning and Route Marker Assembly Signs

a. Panels Fabrication of all sign panels from high-density, overlaid plywood shall be performed in a uniform manner. All fabrication, including cutting, drilling, and edge routing, shall be completed prior to painting and application of reflective sheeting to the high-density, overlaid plywood. Panels shall be cut to size and shall be plywood. Panels shall be cut to size and shall be free of warping, open checks, open splits, open

joints, open cracks, loose knots and other defects resulting from fabrication. Corners shall be left square. The surface of all sign panels shall be flat.

The edge and back of the plywood shall be painted with an exterior grade dark green paint.

b. Blanks Sign blanks shall be cut to shape using a saw blade that does not tear plywood grain. Holes shall be clean-cut and uniform. All cracks, open checks, open splits and other defects occurring on the edge surfaces shall be filled with a synthetic wood filler and sanded smooth prior to sealing and painting. The sign blank edges shall be sealed using an approved sealer/primer. The edges shall then be painted with an exterior grade, dark green paint.

The surface shall not be painted before application of reflective sheeting. Before applying reflective sheeting, dirt or wax shall be removed by one of the following methods:

1. The surface shall be buffed lightly with solvent-soaked steel wool, fine or medium, using organic solvents, such as lacquer thinner, xylol, heptane, benzene or naphtha, and wiped dry with clean cloths.
2. The panel shall be sanded lightly with fine-grade paper, cleaned with solvent, and wiped dry using clean cloths.

c. Reflective Sheeting The High intensity prismatic reflective sheeting shall be applied directly to the cleaned high-density surface in accordance with the recommendations of the reflective sheeting manufacturer.

d. Text The text for regulatory, warning, confirmation and route marker assembly signs shall be composed of cutout, High intensity prismatic reflective sheeting letters, numerals, symbols and borders or the silver letters may be formed by applying transparent ink to the reflective sheeting background where the silk screen process is used. Other methods to form the text may be used when approved in advance.

The design of the letters, numerals, and symbols, the spacing of the text and the size and spacing of the border shall conform to the MUTCD and Standard Highway Signs.

645.06 Installation of Type I Signs The sign locations shown on the Contract Plans are approximate; exact locations will be determined in the field by the Resident. Signs stockpiled before erection shall be stored in a vertical position and completely covered to avoid staining, weathering, and dirt accumulation.

a. Sign Supports Poles for single and multiple support beam-mounted roadside signs shall be erected plumb, using the leveling nuts supplied with the anchor bolts. When

signs are supported by more than one pole, all poles shall be carefully aligned to avoid warping of the sign panel.

Bridge-mounted sign supports shall be fabricated and assembled in accordance with the details as shown on the Contract Plans and with Section 504. Additionally, if required to be painted, bridge-mounted sign supports shall be painted in accordance with Section 506.

Bridge-type, butterfly and cantilever-type sign supports and their foundations shall be constructed, assembled and erected, in accordance with the manufacturer's details, as approved. All horizontal supports spanning the roadway shall be level and shall have permanent camber as described in Section 10.5 of the current edition of AASHTO "LRFD Specifications for Structural Supports for Highway Signs, Luminaires, and Traffic Signals", and interims thereto. If, at any time after their erection, bridge-type, butterfly or cantilever-type sign supports are to remain for a period in excess of 72 hours without the sign(s) for which they were designed being in place, suitable vibration damping devices, approved by the Resident, shall be installed until such time as the sign(s) can be erected.

Where aluminum surfaces are in contact with concrete or dissimilar metals, the contacting surface shall be thoroughly coated with an approved aluminum impregnated caulking compound, or the surfaces shall be separated by another approved material. Before signs are attached, aluminum sign supports shall be cleaned of all dirt and discoloration using methods recommended by the manufacturer.

b. Sign Panels Extruded aluminum planks for sign panels shall be bolted together, as indicated on the Contract Plans. Extruded aluminum molding shall be placed on the edges of the extruded panels. Sign panels shall be attached to the posts to provide the vertical and horizontal clearances from the roadway as indicated on the Contract Plans. Sign panels on overhead structures shall provide a minimum vertical clearance of 18 feet to the highest point of the roadway surface under the sign(s). Sign panels on bridge-mounted sign supports shall be installed with the bottom edge of the sign approximately 4 inches above the bottom of the bridge beam.

Sign panels mounted over the roadway shall tilt in the direction of the approaching traffic in such a manner that the angle between the sign face and the roadway grade, at the sign location shall be $85^{\circ} \pm 3^{\circ}$.

Ground-mounted signs located 4 to 30 feet from the edge of shoulder shall form an angle of 93° between the approach roadway and the sign.

Signs located more than 30 feet from the edge of the shoulder shall form an angle between the approach roadway and the sign face equal to $87^{\circ} - 1^{\circ}$ for each additional 10 feet beyond 30 feet.

Unless otherwise shown on the Contract Plans, or designated by the Resident, a minimum lateral clearance of 4 feet shall be provided between the edge of the shoulder and the edge of any sign panel.

The elevation of the bottom edge of guide sign panels shall be 7 feet above the elevation of the edge of the traveled way, at the sign location, or in case of a curb section, 7 feet above the elevation of the outer edge of the roadway, unless authorized otherwise.

Signs located 30 feet or more from the edge of traveled way shall be 5 feet above the elevation of the edge of shoulder.

In the event that a second sign is to be placed under the main sign, the elevation of the bottom edge of the principal sign shall be a minimum of 8 feet above the outer edge of the traveled way, or a minimum of 8 feet above the edge of the traveled way, in curbed sections; the bottom edge of the second sign must be at least 5 feet above the edge of the traveled way.

The elevation of the bottom edge of the regulatory, warning and route marker sign panels shall be 6 feet above the elevation of the edge of the pavement, or edge of roadway in curbed sections, at the sign location. The elevation of the bottom edge of these sign panels above the elevation of the edge of the pavement on all crossing or connecting roadways shall be 5 feet in rural areas or 7 feet in urban areas. Field conditions may require some variation in elevations, as directed.

Each sign shall have at least two fasteners connecting it to the sign poles, except signs of 1 foot or less in height may have one fastener.

645.061 Installation of Type II Signs The exact sign locations will be determined in the field. Signs stockpiled before erection shall be stored in a vertical position and completely covered to avoid staining, weathering, and dirt accumulation.

When a steel pole is to be used, before any shop work is commenced, the Contractor shall submit 3 sets of the manufacturer's drawings of all standards and accessories proposed to be furnished and erected under this contract. The drawings shall be of sufficient detail to indicate material and/or dimensional conformance with these specifications and the contract drawings. Each drawing shall contain a reference to the design criteria and certification that the design criteria have been met for current edition of the AASHTO "LRFD Specifications for Structural Supports for Highway Signs, Luminaires, and Traffic Signals", and interims thereto, for bracket arms and associated hardware, fittings and breakaway devices, as submitted. A Professional Engineer licensed in accordance with the State of Maine regulations shall sign the certification under their official seal. The drawings shall use the same units as found in the Contract Plans. It is the intent of these specifications that the Contractor shall be fully responsible for the adequacy of the sizes, wall thickness, materials and connections of the standards, bracket arms and associated hardware, fittings and breakaway devices. Approval

of the drawings will signify only approval of the material(s), mounting heights(s) and bracket arm length(s).

a. Sign Supports Support posts for Type II signs shall be U-channel posts weighing 2½ pounds per foot for signs of less than 6.24 ft² in area, 4 inch by 4 inch wood posts or two U-channel posts weighing 2½ lb/ft for signs of area 6.24 ft² to 9 ft², 4 inch by 6 inch wood posts for signs of area 9 ft² to 16 ft², and 6 inch by 6 inch wood posts for signs of area over 16 ft². All signs 60 inches wide or wider shall be mounted on two wood posts. Wood posts shall be set to a depth of 4 feet. U-channel posts shall be set to a minimum depth of 30 inches. Leading signs less than 9 ft² on the apex of islands will be installed on U-channel posts. Solar powered sign mounted beacon arrays shall be mounted on galvanized steel poles. Any signs installed on/in an island, shall be installed in a PVC sleeve of the appropriate size for the type of post being installed, as shown in the standard details.

When it is necessary to set sign posts in bedrock, holes shall be excavated to the required depth and size at the locations indicated on the Contact Plans. The excavated material will be satisfactorily disposed of, as directed, and the posts set to the required depth.

When installing pressure-treated sign posts, the cut end of the posts shall not be buried in the ground.

Backfilling around the posts shall be with excavated material unless the excavated material is considered unsatisfactory, in which case the backfill shall be granular material conforming to the requirements of Section 703.19 - Granular Borrow. Backfill shall be thoroughly tamped in layers not exceeding 8 inches in depth.

When directed, the area around the posts shall be loamed and seeded in accordance with the applicable provisions of Section 615 and Section 618.

The Contractor shall be responsible for and shall repair all damage to underground drainage structures, utilities, or lighting conduits encountered during placing the posts.

b. Mounting Type II signs shall be mounted using assembly hardware specified in Section 719.07.

PVC pipe shall be installed in all locations where sign posts are to be placed in paved islands and shall have an inside diameter of 12 inches. For sleeves that are to be utilized for U-channel posts, the PVC pipe shall have a minimum length of 3 feet. For sleeves that are to be utilized for wood posts, the PVC pipe shall have a minimum length of 5 feet.

Installation of the PVC pipe shall occur prior to paving of the island. The pipe shall be placed at a depth so that the top of the pipe shall have no more than a 1 inch reveal from finished surface pavement. Once placed, the pipe shall be backfilled around the outside diameter in layers that are thoroughly compacted and that do not exceed a depth of 8 inches.

Once installed and backfilled, the pipe shall be completely filled to the top of the pipe with material that meets the gradation requirements of Aggregate for Untreated Surface Course and Leveling Course Type A or Type B or Underdrain Backfill Material.

645.062 Installation of Delineators Posts for delineators shall be erected so that posts and assemblies will be plumb. All posts, which are bent or otherwise damaged, shall be removed and properly replaced. Posts shall be driven 4 feet from the outside edge of shoulder, 4 feet from the face of curb and 4 feet from the normal edge of shoulder in guardrail sections. A suitable driving cap shall be used and after driving, the top of the post shall have substantially the same cross sectional dimensions as the body of the post.

When bedrock is encountered in erecting posts, the depth to be drilled into the rock shall be determined by the Resident.

After the posts are driven, delineators shall be mounted 4 feet above the elevation of the edge of the traveled way. In the event that a delineator is required to be installed on a bridge structure, it shall be installed by use of a bracket as shown on the Contract Plans.

Sign support posts to be installed in the sleeve shall be plumbed and set in the material which shall be compacted or tamped around the post. The posts shall be placed so that there is a 2 foot maximum distance from the bottom of the retro-reflective strip on the sign post to the paved travelway or shoulder surface. For wooden posts only, 4 feet of the post shall be placed in the sleeve. Other sign support post installation requirements shall be followed as per Section 645 of the Standard Specifications.

645.063 Installation of Breakaway Devices Breakaway devices shall be installed at locations indicated on the Contact Plans by an approved method. Each sign and pole shall be carefully demounted for reinstallation at the same or at a new location. Manufacturer's installation information shall be provided on the project.

If required, poles shall be cut in such a manner that no rough edges will remain. No flame cutting will be permitted. Cut edges on steel poles shall be painted in accordance with Section 645.07.

Existing foundations shall be modified for attachment of the breakaway device as shown on the Contract Plans or approved.

Breakaway devices shall be attached to new foundations in accordance with the recommendations of the breakaway device manufacturer and as approved.

645.064 Installation of Sign Mounted Beacon Array Beacons installation shall conform to current MUTCD standards.

Battery and solar assembly shall be of sufficient size to power sign for 7 days without solar charging. Batteries shall be gel cell or absorbed glass mat (AGM) batteries. Solar panel shall be installed facing true south and 60 degrees from vertical.

Connections to service shall be in accordance with section 643.09.

The cabinet should be positioned on the side of the pole farthest from traffic. Only aluminum and steel cabinets will be accepted. All exposed wiring shall be in accordance with section 715.11.

All wiring shall be in accordance with section 718.01-c.

Beacon Array shall meet testing requirements outlined in sections 643.14 a, b, and e.

645.07 Demounting and Reinstalling Existing Signs and Poles Signs and poles designated to be demounted and not designated to be reinstalled, except those designated to be demounted by others, shall be delivered to the Resident.

Existing sign panels, poles, foundations, and sign hardware, damaged because of the Contractor's operations shall be replaced or repaired by the Contractor to the satisfaction of the Resident.

New or relocated regulatory, warning, confirmation or route marker assembly signs shall be installed the same working day as the corresponding existing signs are demounted. All new or relocated guide signs shall be installed within two working days of the time the corresponding existing sign is demounted. Before the Contractor demounts any regulatory or warning sign, they shall erect a similar easel mounted sign at a designated location. The Contractor shall maintain this temporary sign in place until the permanent sign is installed.

Existing signs and poles shall be reinstalled in accordance with the applicable requirements for installing new signs and poles.

Relocated steel posts and clamps shall be field painted two coats after the posts have been erected. The first coat shall be a zinc-dust primer paint meeting Federal Specification TT-P-641B Type II. The second coat shall be bright aluminum paint, aluminum-dust Type II, Class 3 brightness, meeting Federal Specification TT-A-468 with a minimum of 2 lb/gal, with vehicle meeting or exceeding Federal Specification TT-V-109. Scratches shall be touched up after the erection of the sign panels. The touchup shall be with both primer and finish coat. Sign pole surfaces to be painted shall be cleaned and dry when the paint is applied. No painting shall be done in damp weather nor when the air temperature is below 40°F.

645.08 Method of Measurement Demount Signs, Demount Poles, Reinstall Signs, and Reinstall Poles will be measured by each unit.

Bridge-type, cantilever and butterfly-type Sign Support Structures, including the foundations and sign panels, complete in place, as called for on the Contract Plans, will be measured by each unit.

Bridge-Mounted Guide Signs, including supports, will be measured by each unit in place.

Breakaway devices (1 per pole) shall be measured by the unit complete in place and accepted.

The area of roadside guide signs, regulatory, warning, confirmation and route marker assembly signs of the respective types, will be measured by the area in square feet, computed to nearest hundredth of a square foot, as determined by the overall height multiplied by the overall width.

Aluminum poles for roadside guide signs, Type I will be measured by the number of units of each diameter, complete in place. Steel H-beam poles will be measured for payment by the pound, determined from the nominal weight per foot for each size and the lengths as indicated on the Contract Plans.

Demountable reflectorized delineators will be measured by the number of units of each type in place.

All beacons installed on an individual post/pole shall constitute a single installation. Each installation will be measured for payment by the lump sum in place

645.09 Basis of Payment The accepted demounted signs and demounted poles will be paid for at the contract unit price each for the respective item specified. Such price will be full compensation for delivering signs and poles not to be reinstalled to a site designated by the Resident, and all other incidentals necessary to complete the work.

The accepted reinstalled signs or reinstalled poles will be paid for at the contract unit price each. Such price will be full compensation for furnishing new hardware, when required, and all incidentals necessary to complete the installations. All signs or poles designated to be reinstalled that are damaged by the Contractor shall be replaced by the Contractor with new signs or poles conforming to the applicable Specifications at no additional cost to the State.

The accepted bridge-type, cantilever and butterfly-type Sign Support Structures will be paid for at the contract lump sum price for the respective items. Such price will be full compensation for the signs, support structures, foundations, and incidentals necessary to complete the work, including design of the sign supports.

The accepted guide signs-overpass mounted, will be paid for at the contract lump sum price for the respective items, which price will be full compensation for the signs, supports and incidentals necessary to complete the work, including design of the sign supports.

The accepted roadside guide signs and regulatory, warning, confirmation, and route marker assembly signs will be paid for at the contract unit price per square foot. Such payment will be full compensation for furnishing and installing signs, assembly hardware, and all incidentals necessary to complete the work, including design of the sign supports.

The accepted aluminum poles will be paid for at the contract unit price each for the specified diameter, complete in place.

The accepted demountable reflectorized delineators will be paid for at the contract unit price each for the type specified, which payment will be full compensation for delineator and post or bridge rail mounting, complete in place.

Payment for breakaway devices shall be full compensation for furnishing and installing the device, all required pole cutting, for adapting the pole to the breakaway device, for adapting the concrete base to the breakaway device and all other incidentals necessary to complete the work. Separate payment will be made at the respective contract unit prices for demounting and reinstalling the signs and the poles at multi-pole installations. At single-pole installations, separate payment will be made at the respective contract unit prices for demounting and reinstalling the poles only.

The accepted quantity of steel H-beam poles will be paid for at the contract unit price per pound, complete in place as shown on the Contract Plans or as designated.

Furnishing and installing posts for Type II signs, including earth excavation and backfilling, furnishing and placing assembly hardware, backfilling material, loam, seed and other incidentals, will not be paid for directly but will be considered incidental to the cost of the signs they support.

Sign Mounted Beacon Arrays will be paid for at the contract lump sum price, which payment will be full compensation for furnishing all materials including, but not limited to the LED-arrays, flasher, timer, controller cabinets, wiring, pedestrian push buttons, solar panels, batteries, radio devices, radar units, and all appurtenances and incidentals required for a complete and functioning installation and for furnishing all tools and labor necessary for completing the installation. Array must meet all testing and connection requirements of this section

All work, PVC Pipe, Aggregate for Untreated Surface Course and Leveling Course, Underdrain Backfill Material and other materials furnished to install, backfill around, and fill the sleeve in the island and place the sign post in the sleeve shall be incidental to the Section 645 Items.

Payment for excavation of solid bedrock for the placement of wood poles will be made under Item 206.07.

Payment will be made under:

<u>Pay Item</u>		<u>Pay Unit</u>
645.103	Demount Guide Sign	Each
645.106	Demount Regulatory, Warning, Confirmation and Route Marker Assembly Sign	Each
645.108	Demount Pole	Each
645.113	Reinstall Guide Sign	Each
645.116	Reinstall Regulatory, Warning, Confirmation and Route Marker Assembly Sign	Each
645.118	Reinstall Pole	Each
645.12	Overhead Guide Sign: (STA X + XXX)	Lump Sum
645.13	Bridge Overpass-Mounted Guide Sign: (STA X + XXX) (Left/Right XX)	Lump Sum
645.14	Special Work No.: ____	Lump Sum
645.15	Cantilever Guide Sign: (STA X + XXX)	Lump Sum
645.161	Breakaway Device Single Pole	Each
645.162	Breakaway Device Multi Pole	Each
645.251	Roadside Guide Signs, Type I	Square Foot
645.261	Bridge Guide Sign, Type I	Square Foot
645.271	Regulatory, Warning, Confirmation and Route Assembly Sign, Type I	Square Foot
645.281	5 Inch Aluminum Pole	Each
645.282	6 Inch Aluminum Pole	Each
645.283	7 Inch Aluminum Pole	Each
645.284	8 Inch Aluminum Pole	Each
645.285	10 Inch Aluminum Pole	Each
645.286	12 Inch Aluminum Pole	Each
645.289	Steel H-Beam Poles	Pounds
645.291	Roadside Guide Signs Type II	Square Foot
645.292	Regulatory, Warning, Confirmation and Route Marker Assembly Signs Type II	Square Foot
645.301	Demountable Reflectorized Delineator, Single	Each
645.302	Demountable Reflectorized Delineator, Double	Each
645.305	Sign Mounted Beacon Array	Lump Sum

SECTION 652 MAINTENANCE OF TRAFFIC

652.2.4 Other Devices Revise this Section by removing the following paragraph:
“ STOP/SLOW paddles shall be the primary and preferred hand held signaling device. Flags shall be limited to Emergencies. The paddle shall have an octagonal shape and be at least 18 inches wide with letters at least 6 inches high and should be fabricated from semi-rigid material”

And replace with these paragraphs:

“Flaggers shall use a STOP / SLOW hand held paddle as the primary and preferred hand signaling device. Flags shall only be limited to emergencies.

STOP / SLOW paddles shall have high intensity prismatic retro reflective sheeting, have an octagonal shape on a rigid handle and shall be at least 18 inches wide with letters at least 6 inches high and shall be constructed from light semi-rigid material. The STOP (R1-1) face shall have white letters and a white border on a red background. The SLOW (W20-8) face shall have black letters and a black border on an orange background.

STOP / SLOW paddles shall also incorporate either white or red flashing lights on the STOP face and white or yellow flashing lights on the SLOW face of the paddle and always be in use. Paddles must conform to any of the following patterns:

A. Two white or red lights (colors shall be all white or all red), one centered vertically above and one centered vertically below the STOP legend; and/or two white or yellow lights (colors shall be all white or all yellow), one centered vertically above and one centered vertically below the SLOW legend;

B. Two white or red lights (colors shall be all white or all red), one centered horizontally on each side of the STOP legend; and/or two white or yellow lights (colors shall be all white or all yellow), one centered horizontally on each side of the SLOW legend;

C. One white or red light centered below the STOP legend; and/or one white or yellow light centered below the SLOW legend;

D. A series of eight or more small all white or all red lights no larger than 1/4 inch in diameter along the outer edge of the paddle, arranged in an octagonal pattern at the eight corners of the border of the STOP face; and/or a series of eight or more small all white or all yellow lights no larger than 1/4 inch in diameter along the outer edge of the paddle, arranged in a diamond pattern along the border of the SLOW face; or

E. A series of white lights forming the shapes of the letters in the legend.

Flashing light patterns shall be compliant with Section 6E.03 Hand Signaling Devices in the most current version of the Manual on Uniform Traffic Control Devices.

All flashing light patterns on the STOP / SLOW paddle shall be visible from a minimum distance of 1000 feet.”

652.3.3 Submittal of Traffic Control Plan On page **6-148**;

Note **b**, revise this section by replacing “5 minutes” with “**10 minutes**” so that the sentence reads: “**The Contractor shall conduct the Work such that traffic delays do not exceed 10 minutes unless longer periods are authorized by the department.**”

Note **f**, in the last sentence revise the “105.2.2” to “105.2.3” so that the last sentence reads, “**For a related provision, see Section 105.2.3 – Project Specific Emergency Planning.**”.

652.3.4 General Revise the eighth paragraph by removing “Earth Berm” and replace it with “**Concrete Barrier**”.

Amend this section by adding the following paragraph before the paragraph beginning with “Special Detours and temporary structures...”:

“A temporary ramp shall be constructed with HMA at the ends of the roadway section paved or milled each day. The use of millings or RAP will not be allowed, but cold patch may be temporarily utilized until HMA plants are open for the season. The maximum ramp change in elevation shall not exceed 4” vertical. For Interstate Highways or roadways with speed limits equaling or exceeding 50 mph; temporary ramps shall be constructed at a length of eight feet per inch of transition depth. For roadways with speed limits less than 50 mph and greater than 25 mph, temporary ramps shall be constructed at a length of four feet per inch of transition depth. For roadways with speed limits 25 mph or less, temporary ramps shall be constructed at a length of two feet per inch of transition depth. Materials, placement, maintenance, and removal shall be incidental to contract items.”

652.4 Flaggers Revise this section by removing the first paragraph, and replace it with the following”

“The Contractor shall furnish flaggers as required by the TCP or as otherwise specified by the Resident. All flaggers must have successfully completed a flagger test approved by the Department and administered by a Department-approved Flagger-Certifier. All flaggers must carry an official certification card with them at all times while flagging.

For daytime conditions, flaggers shall wear a top (vest, shirt or jacket) that is orange, yellow, yellow-green, or fluorescent versions of these colors meeting ANSI 107-2004, Class 2 or Class 3, along with a hardhat with 360 ° retro-reflectivity.

For nighttime conditions, flaggers shall wear all Class 3 apparel, meeting ANSI 107-2004, including a Class 3 top (vest, shirt or jacket) and a Class E bottom (pants or coveralls), shall be worn along with a hardhat with 360 ° retro-reflectivity and shall be visible at a minimum distance of 1000 ft. Flagger stations must be illuminated in nighttime conditions to assure visibility and will be specifically addressed in detail in the Contractor’s TCP”.

652.41 TRAFFIC OFFICERS

Revise this subsection so that the subsection number and title is

“652.4.1 TRAFFIC OFFICERS ”

652.6.1 Daylight Work Times Revise this section by removing the word “table” in the first sentence and replacing it with “times procured”. Also remove the link <http://www.sunrisesunset.com/usa/Maine.asp> and replace with <https://www.sunrisesunset.com/usa/Maine/>.

SECTION 654
VACANT

Change this Section to:

SECTION 654
INTELLIGENT TRANSPORTATION SYSTEMS
RESERVED

SECTION 656
TEMPORARY SOIL EROSION AND WATER POLLUTION CONTROL

656.3.4 Water Pollution Control Requirements Revise this section by adding the following to the end:

“g. Water withdrawals for dust control or moisture control for compaction is prohibited from waterbodies in Maine that have identified invasive plant infestations. For current information and a map of waterbodies where withdrawal is prohibited, visit the DEP website; <https://www.maine.gov/dep/water/invasives/>. Under the heading, “Control” there is a link to infested waterbodies. “

656.5.2 If No Pay Item Add the following to the end of the first paragraph:

“Failure by the Contractor to follow Standard Specification or Special Provision - Section 656 will result in a violation letter and a reduction in payment as shown in the schedule list in 656.5.1. The Department’s Resident or any other representative of The Department reserves the right to suspend the work at any time and request a meeting to discuss violations and remedies. The Department shall not be held responsible for any delay in the work due to any suspension under this item.”

SECTION 660
ON-THE-JOB TRAINING

660.06 Method of Measurement

Remove the first sentence in its entirety and replace with “ **The OJT item will be measured by the number of OJT hours by a trainee who has successfully completed an approved training program.**”

660.07 Basis of payment to the Contractor

Remove the last word in the first sentence so that the first sentence reads “ The OJT shall be paid for once successfully completed at the contract unit price per **hour.**”

Payment will be made under

Change the Pay Item from “660.22” to “**660.21**” and change the Pay Unit from “Each” to “**Hour**”.

SECTION 672
PRECAST CONCRETE BLOCK GRAVITY WALL

672.031 Concrete Units Revise this section by making the following changes:

In the second paragraph remove “A” and underline “**Materials**”.

In the third paragraph remove “B” and underline “**Quality Control and Quality Assurance**”.

Revise this section by removing the paragraph “C Construction...” and replacing it with:

“Construction. Construction requirements are modified as follows:

Add the following paragraph at the end of the Construction section:

Face texture of the units shall be a formed finish on all exposed surfaces. Pigment shall be added during the casting process of the concrete unit to achieve a consistent shade of gray or other color as determined by the Resident.

Curing. Curing requirements are modified as follows:

Replace the first sentence in the paragraph which begins “Forms shall remain ...” with the following:

The forms shall remain in place until the concrete has gained sufficient strength such that removal of the forms and subsequent handling will not damage the units.”

In the paragraph beginning with “D” remove “D” and underline “**Concrete Testing**”.

In the paragraph beginning with “E” remove the “E” and underline “**Tolerances**”. Also in this paragraph add “**Replace Tolerance contents in 712.061 with the following:**” after Tolerances.

672.035 Backfill Material– Revise this section by adding the following after the second paragraph:
Backfill materials shall meet the criteria in the following table.

<u>Base Polymer</u>	<u>Property</u>	<u>Criteria</u>	<u>Test Method</u>
Polyester (PET)	pH	3 < pH < 9	AASHTO T-289
Polyolefin (PP & HDPE)	pH	pH > 3	AASHTO T-289

672.04 Design Requirements – Revise this section by replacing items 2 and 3 in the second paragraph with the following:

- 2. FHWA-NHI-10-024 and FHWA-NHI-10-025, Design and Construction of Mechanically Stabilized Earth Walls and Reinforced Soil Slopes, Volumes I and II, current edition.**
- 3. FHWA-NHI-09-087 Corrosion/Degradation of Soil Reinforcements for Mechanically Stabilized Earth Walls and Reinforced Soil Slopes, current edition.**

SECTION 673
WETCAST SMALL LANDSCAPE BLOCK WALL

673.031 Concrete Units Revise this section by making the following changes:

In the second paragraph remove “A” and underline “**Materials**”.

In the third paragraph remove “B” and underline “**Quality Control and Quality Assurance**”.

Revise this section by removing the paragraph “C Construction...” and replacing it with:

“Construction Add the following paragraph at the end of the Construction section:

Face texture of the units shall be a formed finish on all exposed surfaces.

Pigment shall be added during the casting process of the concrete unit to achieve a consistent shade of gray or other color as determined by the Resident.

Curing. Curing requirements are modified as follows:

Replace the first sentence in the paragraph which begins “Forms shall remain ...” with the following:

The forms shall remain in place until the concrete has gained sufficient strength such that removal of the forms and subsequent handling will not damage the units.”

In the paragraph beginning with “D” remove “D” and underline “**Concrete Testing**”.

In the paragraph beginning with “E” remove the “E” and underline “**Tolerances**”. Also in this paragraph add “**Replace Tolerance contents in 712.061 with the following:**” after Tolerances.

673.035 Backfill Material – Revise this section by adding the following after the second paragraph:

Backfill materials shall meet the criteria in the following table.

<u>Base Polymer</u>	<u>Property</u>	<u>Criteria</u>	<u>Test Method</u>
Polyester (PET)	pH	3 < pH < 9	AASHTO T-289
Polyolefin (PP & HDPE)	pH	pH > 3	AASHTO T-289

673.04 Design Requirements – Revise this section by replacing items 2 and 3 in the second paragraph with the following:

2. FHWA-NHI-10-024 and FHWA-NHI-10-025, Design and Construction of Mechanically Stabilized Earth Walls and Reinforced Soil Slopes, Volumes I and II, current edition.

3. FHWA-NHI-09-087 Corrosion/Degradation of Soil Reinforcements for Mechanically Stabilized Earth Walls and Reinforced Soil Slopes, current edition

SECTION 674

PREFABRICATED CONCRETE MODULAR GRAVITY WALL

674.02 Materials Amend this section by replacing the last sentence in the first paragraph which begins with “Materials shall...” with the following: **“Modify requirements in 712.061 as follows:”**.

Amend this section by adding the following after **“Concrete Units:”** and before the paragraph beginning with **“Tolerances ”**.

Concrete shall be Class P. The concrete shall contain a minimum of 5.5 gallons per cubic yard of calcium nitrite solution.

The minimum permeability of the concrete as indicated by Surface Resistivity shall be 17 KOhm-cm.

Defects Defects which may cause rejection of precast units include, but are not limited to, the following:

Any discontinuity (crack, rock pocket, etc.) of the concrete which could allow moisture to reach the reinforcing steel.

Rock pockets or honeycomb over 6 square inches in area or over 1 inch deep.

Edge or corner breakage exceeding 12 inches in length or 1 inch in depth.

Any other defect that clearly and substantially impacts the quality, durability, or maintainability of the structure, as determined by the Fabrication Engineer.

Repair honeycombing, ragged or irregular edges and other non-structural or cosmetic defects using a patching material from the MaineDOT Qualified Products List (QPL). The repair, including preparation of the repair area, mixing and application and curing of the patching material, shall be in accordance with the manufacturer's product data sheet. Corners that are not exposed in the final product may be ground smooth with no further repair necessary if the depth of the defect does not exceed 1/2 inch. Remove form ties and other hardware to a depth of not less than 1 inch from the face of the concrete and patch the holes using a patching material from the MaineDOT QPL.

Repair structural defects only with the approval of the Fabrication Engineer. Submit a nonconformance report (NCR) to the Fabrication Engineer with a proposed repair procedure. Do not perform structural repairs without an NCR that has been reviewed by the Fabrication Engineer. Structural defects include, but are not be limited to, exposed reinforcing steel or strand, cracks in bearing areas, through cracks and cracks 0.013 inch in width that extend more than 12 inches in length in any direction. Give the QAI adequate notice prior to beginning any structural repairs.

SECTION 677

MECHANICALLY STABILIZED EARTH RETAINING WALL

677.03 Design Requirements – Revise this section by replacing items 6, 7 and 8 in the second paragraph with the following:

6. FHWA-NHI-10-024, Design and Construction of Mechanically Stabilized Earth Walls and Reinforced Soil Slopes, Volumes I, current edition.
7. FHWA-NHI-10-025, Design and Construction of Mechanically Stabilized Earth Walls and Reinforced Soil Slopes, Volumes II, current edition.
8. FHWA-NHI-09-087 Corrosion/Degradation of Soil Reinforcements for Mechanically Stabilized Earth Walls and Reinforced Soil Slopes, current edition

On page 6 - 203 change “636.041” to “677.041”

Amend 677.042 Precast Panel Tolerances and Surface Finish by the addition of the following:

Defects Defects which may cause rejection of precast units include, but are not limited to, the following:

Any discontinuity (crack, rock pocket, etc.) of the concrete which could allow moisture to reach the reinforcing steel.

Rock pockets or honeycomb over 6 square inches in area or over 1 inch deep.

Edge or corner breakage exceeding 12 inches in length or 1 inch in depth.

Any other defect that clearly and substantially impacts the quality, durability, or maintainability of the structure, as determined by the Fabrication Engineer.

Repair honeycombing, ragged or irregular edges and other non-structural or cosmetic defects using a patching material from the MaineDOT Qualified Products List (QPL). The repair, including preparation of the repair area, mixing and application and curing of the patching material, shall be in accordance with the manufacturer's product data sheet. Corners that are not exposed in the final product may be ground smooth with no further repair necessary if the depth of the defect does not exceed 1/2 inch. Remove form ties and other hardware to a depth of not less than 1 inch from the face of the concrete and patch the holes using a patching material from the MaineDOT QPL.

Repair structural defects only with the approval of the Fabrication Engineer. Submit a nonconformance report (NCR) to the Fabrication Engineer with a proposed repair procedure. Do not perform structural repairs without an NCR that has been reviewed by the Fabrication Engineer. Structural defects include, but are not be limited to, exposed reinforcing steel or strand, cracks in bearing areas, through cracks and cracks 0.013 inch in width that extend more than 12 inches in length in any direction. Give the QAI adequate notice prior to beginning any structural repairs.

SECTION 681

PRECAST AGGREGATE-FILLED, CONCRETE BLOCK GRAVITY WALL

681.031 Concrete Units Revise this section by making the following changes:

In the second paragraph remove “A” and underline “**Materials**”.

In the third paragraph remove “B” and underline “**Quality Control and Quality Assurance**”.

In the fourth paragraph remove “C” and underline “**Construction**”.

In the fifth paragraph remove “D” and underline “Concrete Testing”.
In the sixth paragraph remove the “E” and underline “Tolerances”.

SECTION 702 **BITUMINOUS MATERIAL**

702.01 Asphalt Cement - Remove this section in its entirety and replace with the following:

Performance-Graded Asphalt Binder (PGAB) that has not been modified with polymer shall conform to the requirements of AASHTO M 320. Polymer modified binder shall meet the requirements of AASHTO M 332 and AASHTO R 92, except that the percent difference in nonrecoverable creep compliance, Jnr diff, shall not be enforced. Performance-Graded Asphalt Binder shall not contain re-refined engine oil bottoms (REOB).

The Contractor shall arrange for the Supplier to furnish the following items to the Department’s Asphalt Pavement Engineer:

a. A Quality Control Plan that conforms to the requirements of AASHTO R 26 “Certifying Suppliers of Performance-Graded Asphalt Binders” and

b. A CERTIFICATE OF ANALYSIS for all asphalt materials furnished for use on the project. The Certificate shall include the actual test results of the material in storage from which the shipments are being made. Certificates shall be supplied for each lot, batch, or blend of each type and grade of material. A new certificate shall be issued at least every 30 days or upon receiving or manufacture of a new material. The original of each Certificate of Analysis shall be mailed to the Departments Asphalt Pavement Engineer.

The Contractor shall give the supplier sufficient notice of orders to permit testing and certification. Material not certified will not be accepted for use.

Deliveries of asphalt materials shall be accompanied by a Bill of Lading containing the information required under Section 108.1.3 f. The Bill of Lading shall include the applicable certificate number and shall include a printed or stamped statement such as the following: “THIS IS TO CERTIFY THAT THE ASPHALT MATERIAL REPRESENTED BY THIS LOADING INVOICE CONFORMS TO THE SPECIFICATIONS OF THE PURCHASER FOR THE MATERIAL TYPE AND GRADE STATED THEREON.”

In the event an intermediate hauler of the asphalt material is involved, a copy of their own delivery slip shall be furnished, as well as a copy of the supplier's loading invoice. The hauler's delivery slip and the supplier's loading invoice shall be cross-referenced by use of their respective serial numbers.

All non-bituminous components added to the binder prior to the sampling point for binder certification shall be included on the asphalt binder Certificate of Analysis identifying their presence. All non-bituminous components added after the certification sampling point and prior to transport shall be included on the Bill of Lading. All non-bituminous components added to the binder at the HMA plant shall be identified on the mix plant documentation and accompanied by test results and certification showing the effect of the additives introduced, if any.

702.04 Emulsified Asphalt

Revise this Section by removing the first paragraph in its entirety and replace with the following:

Emulsified Asphalt shall conform to the requirements of AASHTO M 140. Cationic emulsified asphalt shall conform to the requirements of AASHTO M 208. Anionic emulsified asphalt Grade RS-1h shall conform to the requirements in the following table:

Type	Rapid-Setting	
Grade	RS-1h	
Tests on Emulsions	min	max
Viscosity, Saybolt Furol at 25°C SFS	20	100
Storage Stability test, 24-h, % ^A	-	1.0
Demulsibility, 35 ml, 0.02 N CaCl ₂ , %	60	-
Sieve Test, % ^A	-	0.10
Residue by distillation, %	55	-
Tests on Residue from Distillation Test	min	max
Penetration, 25°C 100g, 5 s	40	90
Ductility, 25°C 5 cm/min, cm	40	-
Solubility in trichloroethylene or n-propyl bromide, %	97.5	-

^A This requirement is waived if successful application of material has been achieved in the field.

SECTION 703
AGGREGATES

703.01 Fine Aggregate for Concrete Replace the second paragraph with the following:

“All fine aggregate shall be free from injurious amounts of organic impurities. Should the fine aggregate, when subjected to the colorimetric test for organic impurities, AASHTO T 21, produce a color darker than organic plate number 3, the fine aggregate shall be rejected.”

703.0201 Alkali Silica Reactive Aggregates. Remove this section in its entirety and replace with the following:

All coarse and fine aggregates proposed for use in concrete shall be tested for Alkali Silica Reactivity (ASR) potential under AASHTO T 303 (ASTM C 1260), Accelerated Detection of Potentially Deleterious Expansion of Mortar Bars Due to Alkali-Silica Reaction, prior to

being accepted for use. Acceptance will be based on testing performed by an accredited independent lab submitted to the Department. Aggregate submittals will be required on a 5-year cycle, unless the source or character of the aggregate in question has changed within 5 years from the last test date.

As per AASHTO T 303 (ASTM C 1260): Use of a particular coarse or fine aggregate will be allowed with no restrictions when the mortar bars made with this aggregate expand less than or equal to 0.10 percent at 30 days from casting. Use of a particular coarse or fine aggregate will be classified as potentially reactive when the mortar bars made with this aggregate expand greater than 0.10 percent at 30 days from casting. Use of this aggregate will only be allowed with the use of cement-pozzolan blends and/or chemical admixtures that result in mortar bar expansion of less than 0.10 percent at 30 days from casting as tested under ASTM C 1567.

Acceptable pozzolans and chemical admixtures that may be used when an aggregate is classified as potentially reactive include, but are not limited to the following:

Class F Coal Fly Ash meeting the requirements of AASHTO M 295.

Ground Granulated Blast Furnace Slag (Grade 100 or 120) meeting the requirements of AASHTO M 302.

Densified Silica Fume meeting the requirements of AASHTO M 307.

Lithium based admixtures

Metakaolin

Pozzolans or chemical admixtures required to offset the effects of potentially reactive aggregates will be incorporated into the concrete at no additional cost to the Department.

703.06 Aggregate for Base and Subbase - Remove the first two paragraphs in their entirety and replace with these:

“The following shall apply to Sections (a.) and (c.) below. The material shall have a Micro-Deval value of 25.0 or less as determined by AASHTO T 327. If the Micro-Deval value exceeds 25.0, the Washington State Degradation DOT Test Method T113, Method of Test for Determination of Degradation Value (January 2009 version) shall be performed, except that the test shall be performed on the portion of the sample that passes the 1/2 in sieve and is retained on the No. 10 sieve. If the material has a Washington Degradation value of less than 15, the material shall be rejected.

The material used in Section (b.) below shall have a Micro-Deval value of 25.0 or less as determined by AASHTO T 327. If the Micro-Deval value exceeds 25.0 the material may be used if it does not exceed 25 percent loss on AASHTO T 96, Resistance to Degradation of Small-Size Coarse Aggregate by Abrasion and Impact in the Los Angeles Machine. “

703.081 RAP for Asphalt Pavement

Remove this section in its entirety and replace with the following:

703.081 RAP for Asphalt Pavement Recycled Asphalt Pavement (RAP) may be introduced into hot-mix asphalt pavement at percentages approved by the Department according to the MaineDOT Policies and Procedures for HMA Sampling and Testing.

If approved by the Department, the Contractor shall provide documentation stating the source, test results for average residual asphalt content, and stockpile gradations showing RAP materials have been sized to meet the maximum aggregate size requirements of each mix designation. The Department will obtain samples for verification and approval prior to its use.

The maximum allowable percent of RAP shall be determined by the asphalt content, the percent passing the 0.075 mm sieve, the ratio between the percent passing the 0.075 mm sieve and the asphalt content, and Coarse Micro-Deval loss values as tested by the Department. The maximum percentage of RAP allowable shall be the lowest percentage as determined according to Table 4 below:

Table 4: Maximum Percent RAP According to Test Results

Classification	Maximum RAP Percentage Allowed	Asphalt content standard deviation	Percent passing 0.075 mm sieve standard deviation	Percent passing 0.075 mm sieve / asphalt content ratio	Residual aggregate M-D loss value
Class III	10%	≤ 1.0	N/A	≤ 4.0	≤ 18
Class II	20%	≤ 0.5	≤ 1.0	≤ 2.8	
Class I	30%	≤ 0.3	≤ 0.5	≤ 1.8	

The Department will monitor RAP asphalt content and gradation during production by testing samples from the stockpile at approximately 15,000 T intervals (in terms of mix production). The allowable variance limits (from the numerical average values used for mix designs) for this testing are determined based upon the maximum allowable RAP percentage, and are shown below in Table 5.

Table 5: RAP Verification Limits

Classification	Asphalt content (compared to aim)	Percent passing 0.075 mm sieve (compared to aim)
Class III	± 1.5	± 2.0

Class II	± 1.0	± 1.5
Class I	± 0.5	± 0.7

For specification purposes, RAP will be categorized as follows:

Class III – A maximum of 10.0 percent of Class III RAP may be used in any base, intermediate base, surface, or shim mixture. A maximum of 20.0 percent of Class III RAP may be used in hand-placed mixes for item 403.209.

Class II – A maximum of 20.0 percent Class II RAP in any base, binder, surface, or shim course.

Class I – A maximum of 20.0 percent Class I RAP may be used in any base, intermediate base, surface, or shim mixture without requiring a change to the specified asphalt binder. A maximum of 30.0 percent Class I RAP may be used in in any base or intermediate base mixture provided that a PG 58-28 or PG 58-34 asphalt binder is used. A maximum of 30.0 percent Class I RAP may be used in any surface or shim mixture provided that PG 58-34 asphalt binder is used. Mixtures exceeding 20.0 percent Class I RAP must be evaluated and approved by the Department.

The Contractor may use up to two different RAP sources in any one mix design. The total RAP percentage of the mix shall not exceed the maximum allowed for the highest classification RAP source used (i.e. if a Class I & Class III used, total RAP must not exceed 30.0%). The blended RAP material must meet all the requirements of the classification for which the RAP is entered (i.e. 10% Class III with 20% Class I, blend must meet Class I criteria). The Department may take belt cuts of the blended RAP to verify the material meets these requirements. If the Contractor elects to use more than one RAP source in a design, the Contractor shall provide an acceptable point of sampling blended RAP material from the feed belt.

In the event that RAP source or properties change, the Contractor shall notify the Department of the change and submit new documentation stating the new source or properties a minimum of 72 hours prior to the change to allow for obtaining new samples and approval.

703.19 Granular Borrow

Remove the gradation requirements table, and replace with the following:

Sieve Designation	Percentage by Weight Passing Square Mesh Sieves	
	Material for Underwater Backfill	Material for Embankment Construction
6 inch	100	
No. 40	0-70	0-70
No. 200	0-7.0	0-20.0

703.33 Stone Ballast - In the third paragraph, remove the words “less than” before 2.60 and add the words “or greater” after 2.60.

SECTION 705
JOINT MATERIAL

705.03 Flexible Watertight Gaskets Revise this section by deleting it in its entirety and replace with “**Flexible gaskets, either rubber or plastic, shall conform to ASTM C990**”

SECTION 708
PAINTS AND PRESERVATIVES

708.05 Timber Preservative Revise this section by removing it in its entirety and replacing with: “**Timber preservatives shall conform to the requirements of AASHTO M 133 and AWPA Standard U1. All preservatives shall meet the requirements of the US EPA regulations under the Federal Insecticide, Fungicide and Rodenticide Act.**”

SECTION 709
REINFORCING STEEL AND WELDED STEEL WIRE FABRIC

709.01 Reinforcing Steel Revise this section by removing the sentence starting with “The chemical composition...” in the third paragraph and replace it with the following: “**The chemical composition shall conform to one of the types listed in Table 2 of ASTM A955 or UNS S32304 Duplex.**”

SECTION 710 **FENCE AND GUARDRAIL**

710.07 Guardrail Posts Amend subsection 'a' by removing the words "white oak", "cedar", "tamarack", "maple", "beech", "birch" and "red oak" from the first sentence. Also in the first sentence, place an "**or**" between "pine" and "eastern hemlock". In the second sentence remove the words "well seasoned". Remove the sentence beginning with "Wood posts and offset brackets..." and replace it with: "**Wood posts and offset brackets shall be preservative treated in accordance with the requirements of AASHTO M 133 and AWPA U1, UC4A Commodity Specification A: Sawn Products.**"

SECTION 712 **MISCELLANEOUS HIGHWAY MATERIAL**

712.061- Structural Precast Concrete Units

Under the heading, Quality Control and Quality Assurance, revise the fourth paragraph to read:

"Acceptance is the prerogative of the Department. The Department will conduct Quality Assurance (QA) in accordance with Standard Specification Subsection 106.5. Testing deemed necessary by the Department that is in addition to the minimum testing requirements will be scheduled to minimize interference with the production schedule. The QAI will perform acceptance sampling and testing and will witness or review documentation, workmanship and testing to assure the Work is being performed in accordance with the Contract Documents."

Under the heading, Construction, revise the paragraph beginning with " Recess inserts one inch..." by removing the first sentence and replacing it with "**Recess metal inserts and form ties a minimum of one inch, unless noted otherwise in the Contract.**"

Under the heading, Concrete Testing, revise the first paragraph to read as the following two paragraphs:

Concrete Testing Acceptance of structural precast units, for each day's production, will be determined by the Department, based on compliance with this specification and satisfactory concrete testing results.

At least once per week, the QAI will make 2 concrete cylinders (6 cylinders when the Contract includes permeability requirements) for use by the Department; cylinders shall be standard cured in accordance with AASHTO T23 (ASTM C31). The QAI will perform entrained air content and slump flow testing, determine water-cement ratio and determine temperature of the sampled concrete at the time of cylinder casting. All testing equipment required by the QAI to perform this testing shall be in accordance with Standard Specification Section 502.041, Testing Equipment. In addition, the Contractor shall provide a slump cone meeting the requirements of AASHTO T 119. Providing and maintaining testing and curing equipment shall be considered incidental to the work and no additional payment will be made.

Quality Control test cylinders shall be made and tested in accordance with the following standards:

AASHTO T 22 (ASTM C39) Test Method for Compressive Strength of Cylindrical Concrete Specimens

AASHTO T23 (ASTM C31) Practice for Making and Curing Concrete Test Specimens in Field

AASHTO T141 (ASTM C172) Practice for Sampling Freshly Mixed Concrete

AASHTO T152 (ASTM C231) Test Method for Air Content of Freshly Mixed Concrete by the Pressure Method

AASHTO T196 (ASTM C173) Standard Test Method for Air Content of Freshly Mixed Concrete by the Volumetric Method

ASTM C1064 Test Method for Temperature of Freshly mixed Portland Cement Concrete

ASTM C1611 Standard Test Method for Slump Flow of Self-Consolidating Concrete”

Under the heading, Concrete Testing, delete the paragraph that begins:

“At least once per week, the Contractor shall make 2 concrete cylinders.....for use by the Department.....”

Under the heading, Concrete Testing, revise the paragraph beginning with “Perform compressive strength testing...” by replacing the word ”transfer” with the word “**stripping**”.

Under the heading, Concrete Testing, revise letter “b” to only read “Air Content shall be 5.5% to 7.5%.”

Under the heading, Surface Finish and Repairs, Revise this section by removing it and replacing it with:

Surface Finish and Repairs. Exposed surfaces shall be finished and repaired in conformance with the referenced specification. If the finish is not specified, then surfaces shall have a uniform appearance; make repairs to remove and blend fins, patch minor spalls, tie holes, handling device recesses, entrapped air pockets, honeycombing, ragged or irregular edges and other non-structural or cosmetic defects using a patching material from the MaineDOT Qualified Products List (QPL). The repair, including preparation of the repair area, mixing and application and curing of the patching material, shall be in accordance with the manufacturer's product data sheet. Corners not exposed in the final product may be ground smooth with no further repair necessary, if the depth of the defect does not exceed one-half inch. Remove form ties and other hardware to a depth of not less than one inch from the face of the concrete and patch the holes using a patching material from the MaineDOT QPL.

Repair of structural defects: Structural defects include, but are not be limited to, exposed reinforcing steel, cracks in bearing areas, through cracks and cracks

0.013 inch in width that extend more than 12 inches in length in any direction. Repair structural defects only with the approval of the Fabrication Engineer. Submit a nonconformance report (NCR) to the Fabrication Engineer with a proposed repair procedure. Do not perform structural repairs without an NCR that has been reviewed by the Fabrication Engineer. Give the QAI adequate notice prior to beginning any structural repairs.”

SECTION 713

STRUCTURAL STEEL AND RELATED MATERIAL

Section 713.01- Structural Steel Revise this Section by removing the sentence:

“ Impact test sampling and testing procedures shall be in accordance with AASHTO T.”

And replace it with: **“Impact test sampling and testing procedures shall be in accordance with AASHTO T 243 M/T 243 and AASHTO T 244.”**

713.02 High Strength Bolts Revise this section by adding **“F3125, Grade”** after **“ASTM”** in the first and fifth paragraphs. In the fifth paragraph, remove **“They shall meet the chemical and mechanical requirements of ASTM A 325”**

SECTION 717

ROADSIDE IMPROVEMENT MATERIAL

717.02 Agricultural Ground Limestone

In the table after the third paragraph which starts with **“Liquid lime...”** change the Specification for Nitrogen (N) from **“15.5 percent of which 1% is from ammoniac nitrogen and 14.5 /5 is from Nitrate Nitrogen”** to read **“15.5 % of which 1% is from Ammoniacal Nitrogen and 14.5 % is from Nitrate Nitrogen”**

717.061 Erosion Control Blankets Revise this section by removing it in its entirety and replacing it with the following:

“717.061 Erosion Control Blankets Shall consist of a machine produced rolled blanket of biodegradable fibers, evenly distributed over the entire area of blanket, of a consistent thickness, sewn into a biodegradable mesh on the top and bottom surface using a cotton blend thread. The blanket shall remain in place when subject to shear stress of 1.55 lb/ft². The blanket shall remain intact until grass is established. The blanket shall be a product currently listed on the department’s Qualified Products List (QPL) of Erosion Control Products. See Section 618.10 - Seeding, Maintenance and Acceptance.”

SECTION 720
**STRUCTURAL SUPPORTS FOR HIGHWAY SIGNS, LUMINAIRES AND
TRAFFIC SIGNALS**

720.01 Aluminum Supports Revise the first paragraph by removing the words "light standards" from the last sentence. Amend this paragraph by adding "(AWS D1.2)" after "Aluminum D1.2". Further amend this section by adding the following as a new second paragraph:

"All welds shall be inspected and conform with AWS D1.2, Clause 5, Inspection. 100% of welds shall be visually examined (VT). In addition to VT, 10% of all partial joint penetration (PJP) and fillet welds shall be dye penetrant tested (PT); locations to be PT examined will be designated by the QAI. 25% of complete joint penetration (CJP) welds shall be ultrasonic tested (UT) or PT based on the thinner material in the welded joint; joints with thinner material thicknesses less than 0.25 inch shall be PT examined and joints with thinner material thickness equal or greater than 0.25 inch shall be UT examined. Locations to be UT examined will be designated by the QAI. Extent of testing shall conform with AWS D1.2, Clause 5."

720.02 Aluminum Mast Arm and Bracket Arm Revise the first paragraph by removing the words "light standards" from the last sentence. Amend this paragraph by adding "(AWS D1.2)" after "Aluminum D1.2".

Further amend this section by adding the following as a new second paragraph:

"All welds shall be inspected and conform with AWS D1.2, Clause 5, Inspection. 100% of welds shall be visually examined (VT). In addition to VT, 10% of all partial joint penetration (PJP) and fillet welds shall be dye penetrant tested (PT); locations to be PT examined will be designated by the QAI. 25% of complete joint penetration (CJP) welds shall be ultrasonic tested (UT) or PT based on the thinner material in the welded joint; joints with thinner material thicknesses less than 0.25 inch shall be PT examined and joints with thinner material thickness equal or greater than 0.25 inch shall be UT examined. Locations to be UT examined will be designated by the QAI. Extent of testing shall conform with AWS D1.2, Clause 5."

720.10 Wood Utility Pole Amend the first sentence in this section by adding ", Red Pine" after "Douglas Fir".

Replace the paragraph beginning with "Wood Utility poles..." with:

"Wood Utility poles shall be pressure treated, after fabrication in accordance with AASHTO Specifications M 133 and AWP A U1, UC4B, Commodity Specification D: Poles."

720.12 Wood Sign Posts Remove the first sentence and replace with **"Wood sign posts shall be rectangular, straight and sound timber, cut from live growing native spruce, red pine, hemlock or cedar trees, free from loose knots or other structurally weakening defects of importance, such as shake or holes or heart rot."**

Remove the paragraph beginning with "When pressure treated sign posts are called for on the plans ..." with **"When pressure treated sign posts are called for on the plans, the wood shall be Yellow Pine, Number 2 or better, or the species listed above. The pressure treated wood shall meet AASHTO M 133 and AWP A Standard U1, UC4A, Commodity Specification A: Sawn Products."**