

Updated 04/28/17

STATE PROJECT

BIDDING INSTRUCTIONS

FOR ALL PROJECTS:

1. Use pen and ink to complete all paper Bids.
2. As a minimum, the following must be received prior to the time of Bid opening:

For a Paper Bid:

- a) a copy of the Notice to Contractors, b) the completed Acknowledgement of Bid Amendments form, c) the completed Schedule of Items, d) two copies of the completed and signed Contract Offer, Agreement & Award form, e) a Bid Guaranty, (if required), and f) any other certifications or Bid requirements listed in the Bid Documents as due by Bid opening.

For an Electronic Bid:

- a) a completed Bid using Expedite® software and submitted via the Bid Express™ web-based service, b) an electronic Bid Guaranty (if required) or a faxed copy of a Bid Bond (with original to be delivered within 72 hours), and c) any other Certifications or Bid requirements listed in the Bid Documents as due by Bid opening.
3. Include prices for all items in the Schedule of Items (excluding non-selected alternates).
4. Bid Guaranty acceptable forms are:
 - a) a properly completed and signed Bid Bond on the Department's prescribed form (or on a form that does not contain any significant variations from the Department's form as determined by the Department) for 5% of the Bid Amount or
 - b) an Official Bank Check, Cashier's Check, Certified Check, U.S. Postal Money Order or Negotiable Certificate of Deposit in the amount stated in the Notice to Contractors or
 - c) an electronic bid bond submitted with an electronic bid.
5. If a paper Bid is to be sent, "FedEx First Overnight" delivery is suggested as the package is delivered directly to the DOT Headquarters Building located at 16 Child Street in Augusta. Other means, such as U.S. Postal Service's Express Mail has proven not to be reliable.

IN ADDITION, FOR FEDERAL AID PROJECTS:

6. Complete the DBE Proposed Utilization form, and submit with your bid. If you are submitting your bid electronically, you must FAX the form to (207) 624-3431. This is a curable defect.

*If you need further information regarding Bid preparation, call the DOT
Contracts Section at (207) 624-3410.*

*For complete bidding requirements, refer to Section 102 of the Maine Department
of Transportation, Standard Specifications, November 2014 Edition.*

NOTICE

The Maine Department of Transportation is attempting to improve the way Bid Amendments/Addendums are handled, and allow for an electronic downloading of bid packages from our website, while continuing to maintain an optional plan holders list.

Prospective bidders, subcontractors or suppliers who wish to download a copy of the bid package and receive a courtesy notification of project specific bid amendments must fill out the on-line plan holder registration form and provide an email address to the MDOT Contracts mailbox at: MDOT.contracts@maine.gov. Each bid package will require a separate request.

Additionally, interested parties will be responsible for reviewing and retrieving the Bid Amendments from our web site, and acknowledging receipt and incorporating those Bid Amendments in their bids using the Acknowledgement of Bid Amendment Form.

The downloading of bid packages from the MDOT website is not the same as providing an electronic bid to the Department. Electronic bids must be submitted via <http://www.BIDX.com>. For information on electronic bidding contact Rebecca Snowden at rebecca.snowden@maine.gov or Diane Barnes at diane.barnes@maine.gov.

NOTICE

For security and other reasons, all Bid Packages which are mailed, shall be provided in double (one envelope inside the other) envelopes. The *Inner Envelope* shall have the following information provided on it:

Bid Enclosed - Do Not Open

PIN:

Town:

Date of Bid Opening:

Name of Contractor with mailing address and telephone number:

In Addition to the usual address information, the *Outer Envelope* should have written or typed on it:

Double Envelope: Bid Enclosed

PIN:

Town:

Date of Bid Opening:

Name of Contractor:

This should not be much of a change for those of you who use Federal Express or similar services.

Hand-carried Bids may be in one envelope as before, and should be marked with the following information:

Bid Enclosed: Do Not Open

PIN:

Town:

Name of Contractor:

October 16, 2001

STATE OF MAINE DEPARTMENT OF TRANSPORTATION
Bid Guaranty-Bid Bond Form

KNOW ALL MEN BY THESE PRESENTS THAT _____

_____, of the City/Town of _____ and State of _____

as Principal, and _____ as Surety, a

Corporation duly organized under the laws of the State of _____ and having a usual place of

Business in _____ and hereby held and firmly bound unto the Treasurer of

the State of Maine in the sum of _____ for payment which Principal and Surety bind

themselves, their heirs, executors, administrators, successors and assigns, jointly and severally.

The condition of this obligation is that the Principal has submitted to the Maine Department of

Transportation, hereafter Department, a certain bid, attached hereto and incorporated as a

part herein, to enter into a written contract for the construction of _____

_____ and if the Department shall accept said bid

and the Principal shall execute and deliver a contract in the form attached hereto (properly

completed in accordance with said bid) and shall furnish bonds for this faithful performance of

said contract, and for the payment of all persons performing labor or furnishing material in

connection therewith, and shall in all other respects perform the agreement created by the

acceptance of said bid, then this obligation shall be null and void; otherwise it shall remain in full

force, and effect.

Signed and sealed this _____ day of _____ 20_____

WITNESS:

WITNESS

PRINCIPAL:

By _____

By: _____

By: _____

SURETY:

By _____

By: _____

Name of Local Agency: _____

NOTICE

Bidders:

Please use the attached “Request for Information” form when submitting questions concerning specific Contracts that have been advertised for Bid, include additional numbered pages as required. RFI’s may be faxed to 207-624-3431, submitted electronically through the Departments web page of advertised projects by selecting the RFI tab on the project details page or via e-mail to RFI-Contracts.MDOT@maine.gov.

These are the only allowable mechanisms for answering Project specific questions. Maine DOT will not be bound to any answers to Project specific questions received during the Bidding phase through other processes.

When submitting RFIs by Email please follow the same guidelines as stated on the “Request for Information” form and include the word “RFI” along with the Project name and Identification number in the subject line.

Vendor Registration

Prospective Bidders must register as a vendor with the Department of Administrative & Financial Services if the vendor is awarded a contract. Vendors will not be able to receive payment without first being registered. Vendors/Contractors will find information and register through the following link –

<http://www.maine.gov/purchases/venbid/index.shtml>

**STATE OF MAINE DEPARTMENT OF TRANSPORTATION
NOTICE TO CONTRACTORS**

Sealed Bids addressed to the Maine Department of Transportation, Augusta, Maine 04333 and endorsed on the wrapper "Bids for Rolling Dam 2 Bridge Culvert Rehabilitation in the city of **GARDINER**" will be received from contractors at the Reception Desk, Maine DOT Building, Capitol Street, Augusta, Maine, until 11:00 o'clock A.M. (prevailing time) on August 7, 2019 and at that time and place publicly opened and read. Bids will be accepted from all bidders. The lowest responsive bidder must demonstrate previous successful completion of projects of a similar size and scope to be considered for the award of this contract. **We now accept electronic bids for bid packages posted on the bidx.com website. Electronic bids do not have to be accompanied by paper bids. Please note: The Department will accept a facsimile of the bid bond; however, the original bid bond must then be received at the MDOT Contract Section within 72 hours of the bid opening.** Until further notice, dual bids (one paper, one electronic) will be accepted, with the paper copy taking precedence.

Description: WIN 018964.00

Location: In Kennebec County, on Route 24/ River Avenue over Rolling Dam Stream approximately 3.0 miles northerly of Farmingdale town line.

Scope of Work: Rolling Dam 2 bridge culvert rehabilitation plus other incidental work.

For general information regarding Bidding and Contracting procedures, contact George Macdougall at (207) 624-3410. Our webpage at <http://www.maine.gov/mdot/contractors/> contains a copy of the Schedule of Items, Plan Holders List, written portions of bid amendments, drawings, bid results and an electronic form for RFI submittal. For Project-specific information fax all questions to **Project Manager Joel Kittredge** at (207) 624-3431, use electronic RFI form or email questions to RFI-Contracts.MDOT@maine.gov, project name and identification number should be in the subject line. Questions received after 12:00 noon of Monday (or if that Monday is a state holiday, Friday) prior to bid date will not be answered. Bidders shall not contact any other Departmental staff for clarification of Contract provisions, and the Department will not be responsible for any interpretations so obtained. TTY users call Maine Relay 711.

Plans, specifications and bid forms may be seen at the MaineDOT Building in Augusta. They may be purchased from the Department between the hours of 8:00 a.m. to 4:30 p.m. by cash, credit card (Visa/Mastercard) or check payable to Treasurer, State of Maine sent to Maine Department of Transportation, Attn.: Mailroom, 16 State House Station, Augusta, Maine 04333-0016. They also may be purchased by telephone at (207) 624-3536 between the hours of 8:00 a.m. to 4:30 p.m. Full size plans \$7.00 (\$10.50 by mail). Half size plans \$3.50 (\$5.75 by mail), Bid Book \$10 (\$13 by mail), Single Sheets \$2, payment in advance, all non-refundable.

Each Bid must be made upon blank forms provided by the Department and must be accompanied by a bid bond at 5% of the bid amount or an official bank check, cashier's check, certified check, certificate of deposit, or United States postal money order in the amount of \$12,000.00 payable to Treasurer, State of Maine as a Bid guarantee. A Contract Performance Surety Bond and a Contract Payment Surety Bond, each in the amount of 100 percent of the Contract price, will be required of the successful Bidder.

This Contract is subject to all applicable State Laws.

All work shall be governed by *State of Maine, Department of Transportation, Standard Specifications, November 2014 Edition*, price \$10 [\$15 by mail], and *Standard Details, November 2014 Edition*, price \$10 [\$15 by mail]. They also may be purchased by telephone at (207) 624-3536 between the hours of 8:00 a.m. to 4:30 p.m. *Standard Detail* updates can be found at <http://www.maine.gov/mdot/contractors/publications/>.

The right is hereby reserved to the MaineDOT to reject any or all bids.

Augusta, Maine
July 17, 2019



JOYCE NOEL TAYLOR P. E.
CHIEF ENGINEER

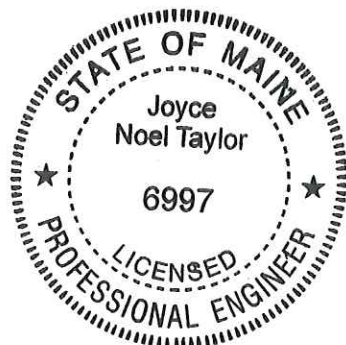

SPECIAL PROVISION 102.7.3
ACKNOWLEDGMENT OF BID AMENDMENTS

With this form, the Bidder acknowledges its responsibility to check for all Amendments to the Bid Package. For each Project under Advertisement, Amendments are located at <http://www.maine.gov/mdot/contractors/> . It is the responsibility of the Bidder to determine if there are Amendments to the Project, to download them, to incorporate them into their Bid Package, and to reference the Amendment number and the date on the form below. The Maine DOT will not post Bid Amendments any later than noon the day before Bid opening without individually notifying all the planholders.

Amendment Number	Date

The Contractor, for itself, its successors and assigns, hereby acknowledges that it has received all of the above referenced Amendments to the Bid Package.

CONTRACTOR

Date

Signature of authorized representative

(Name and Title Printed)

NOTICE TO CONTRACTORS - PREFERRED EMPLOYEES

Sec. 1303. Public Works; minimum wage

In the employment of laborers in the construction of public works, including state highways, by the State or by persons contracting for the construction, preference must first be given to citizens of the State who are qualified to perform the work to which the employment relates and, if they can not be obtained in sufficient numbers, then to citizens of the United States. Every contract for public works construction must contain a provision for employing citizens of this State or the United States. The hourly wage and benefit rate paid to laborers employed in the construction of public works, including state highways, may not be less than the fair minimum rate as determined in accordance with section 1308. Any contractor who knowingly and willfully violates this section is subject to a fine of not less than \$250 per employee violation. Each day that any contractor employs a laborer at less than the wage and benefit minimum stipulated in this section constitutes a separate violation of this section. [1997, c. 757, §1 (amd).]

Maine Department of Transportation

Proposal Schedule of Items

Proposal ID: 018964.00

Project(s): 018964.00

SECTION: 1 Project Items

Alt Set ID: Alt Mbr ID:

Contractor: _____

Proposal Line Number	Item ID Description	Approximate Quantity and Units	Unit Price		Bid Amount	
			Dollars	Cents	Dollars	Cents
0010	203.2318 DISPOSAL OF SPECIAL WASTE	131.000 T	_____	 _____	_____	 _____
0020	502.325 STRUCTURAL CONCRETE CULVERT INVERT LINING	LUMP SUM	_____	 LUMP SUM	_____	 _____
0030	502.326 STRUCTURAL CONCRETE - FISH WEIRS	LUMP SUM	_____	 LUMP SUM	_____	 _____
0040	503.12 REINFORCING STEEL, FABRICATED AND DELIVERED	7,830.000 LB	_____	 _____	_____	 _____
0050	503.13 REINFORCING STEEL, PLACING	7,830.000 LB	_____	 _____	_____	 _____
0060	511.07 COFFERDAM: DOWNSTREAM	LUMP SUM	_____	 LUMP SUM	_____	 _____
0070	511.07 COFFERDAM: UPTREAM	LUMP SUM	_____	 LUMP SUM	_____	 _____
0080	514.06 CURING BOX FOR CONCRETE CYLINDERS	1.000 EA	_____	 _____	_____	 _____
0090	606.366 GUARDRAIL, REMOVE & RESET TYPE 3C	50.000 LF	_____	 _____	_____	 _____
0100	606.367 REPLACE UNUSABLE EXISTING GUARDRAIL POSTS	5.000 EA	_____	 _____	_____	 _____
0110	610.16 HEAVY RIPRAP	120.000 CY	_____	 _____	_____	 _____
0120	615.07 LOAM	2.000 CY	_____	 _____	_____	 _____

Maine Department of Transportation

Proposal Schedule of Items

Proposal ID: 018964.00

Project(s): 018964.00

SECTION: 1 Project Items

Alt Set ID: Alt Mbr ID:

Contractor: _____

Proposal Line Number	Item ID Description	Approximate Quantity and Units	Unit Price		Bid Amount	
			Dollars	Cents	Dollars	Cents
0130	618.14 SEEDING METHOD NUMBER 2	1.000 UN	_____	_____	_____	_____
0140	619.12 MULCH	1.000 UN	_____	_____	_____	_____
0150	619.14 EROSION CONTROL MIX	20.000 CY	_____	_____	_____	_____
0160	620.58 EROSION CONTROL GEOTEXTILE	160.000 SY	_____	_____	_____	_____
0170	629.05 HAND LABOR, STRAIGHT TIME	40.000 HR	_____	_____	_____	_____
0180	631.12 ALL PURPOSE EXCAVATOR (INCLUDING OPERATOR)	20.000 HR	_____	_____	_____	_____
0190	631.172 TRUCK - LARGE (INCLUDING OPERATOR)	20.000 HR	_____	_____	_____	_____
0200	639.19 FIELD OFFICE TYPE B	1.000 EA	_____	_____	_____	_____
0210	652.33 DRUM	10.000 EA	_____	_____	_____	_____
0220	652.34 CONE	20.000 EA	_____	_____	_____	_____
0230	652.35 CONSTRUCTION SIGNS	300.000 SF	_____	_____	_____	_____
0240	652.361 MAINTENANCE OF TRAFFIC CONTROL DEVICES	LUMP SUM	_____	LUMP SUM	_____	_____

Maine Department of Transportation

Proposal Schedule of Items

Proposal ID: 018964.00 Project(s): 018964.00

SECTION: 1 Project Items

Alt Set ID: Alt Mbr ID:

Contractor: _____

Proposal Line Number	Item ID Description	Approximate Quantity and Units	Unit Price		Bid Amount	
			Dollars	Cents	Dollars	Cents
0250	652.38 FLAGGER	40.000 HR	_____	 _____	_____	 _____
0260	656.75 TEMPORARY SOIL EROSION AND WATER POLLUTION CONTROL	LUMP SUM	_____	 LUMP SUM	_____	 _____
0270	659.10 MOBILIZATION	LUMP SUM	_____	 LUMP SUM	_____	 _____
Section: 1			Total:		_____	 _____
			Total Bid:		_____	 _____

CONTRACT AGREEMENT, OFFER & AWARD

AGREEMENT made on the date last signed below, by and between the State of Maine, acting through and by its Department of Transportation (Department), an agency of state government with its principal administrative offices located at Child Street, Augusta, Maine, with a mailing address at 16 State House Station, Augusta, Maine 04333-0016, and

_____ a corporation or other legal entity organized under the laws of the State of _____, with its principal place of business located at _____

The Department and the Contractor, in consideration of the mutual promises set forth in this Agreement (the "Contract"), hereby agree as follows:

A. The Work.

The Contractor agrees to complete all Work as specified or indicated in the Contract including Extra Work in conformity with the Contract, WIN **018964.00**, for the **Rolling Dam 2 Bridge Culvert Rehabilitation** in the city of **Gardiner**, County of **Kennebec**, Maine. The Work includes construction, maintenance during construction, warranty as provided in the Contract, and other incidental work.

The Contractor shall be responsible for furnishing all supervision, labor, equipment, tools supplies, permanent materials and temporary materials required to perform the Work including construction quality control including inspection, testing and documentation, all required documentation at the conclusion of the project, warranting its work and performing all other work indicated in the Contract.

The Department shall have the right to alter the nature and extent of the Work as provided in the Contract; payment to be made as provided in the same.

B. Time.

The Contractor agrees to complete all Work, except warranty work, on or before **April 24, 2020**. Further, the Department may deduct from moneys otherwise due the Contractor, not as a penalty, but as Liquidated Damages in accordance with Sections 107.7 and 107.8 of the *State of Maine Department of Transportation Standard Specifications, November 2014 Edition* and related Special Provisions.

C. Price.

The quantities given in the Schedule of Items of the Bid Package will be used as the basis for determining the original Contract amount and for determining the amounts of the required Performance Surety Bond and Payment Surety Bond, and that the amount of this offer is _____

\$_____ Performance Bond and Payment Bond each being 100% of the amount of this Contract.

D. Contract.

This Contract, which may be amended, modified, or supplemented in writing only, consists of the Contract documents as defined in the Plans, Standard Specifications, November 2014 Edition, Standard Details November 2014 Edition as updated through advertisement, Supplemental Specifications, Special Provisions, Contract Agreement; and Contract Bonds. It is agreed and understood that this Contract will be governed by the documents listed above.

E. Certifications.

By signing below, the Contractor hereby certifies that to the best of the Contractor's knowledge and belief:

1. All of the statements, representations, covenants, and/or certifications required or set forth in the Bid and the Bid Documents, including those in the Contract are still complete and accurate as of the date of this Agreement.
2. The Contractor knows of no legal, contractual, or financial impediment to entering into this Contract.
3. The person signing below is legally authorized by the Contractor to sign this Contract on behalf of the Contractor and to legally bind the Contractor to the terms of the Contract.

F. Offer.

The undersigned, having carefully examined the site of work, the Plans, Standard Specifications November 2014 Edition, Standard Details November 2014 Edition as updated through advertisement, Supplemental Specifications, Special Provisions, Contract Agreement; and Contract Bonds contained herein for construction of: **WIN 018964.00 Rolling Dam 2 Bridge Culvert Rehabilitation plus other incidental work**, State of Maine, on which bids will be received until the time specified in the “Notice to Contractors” do(es) hereby bid and offer to enter into this contract to supply all the materials, tools, equipment and labor to construct the whole of the Work in strict accordance with the terms and conditions of this Contract at the unit prices in the attached “Schedule of Items”.

The Offeror agrees to perform the work required at the price specified above and in accordance with the bids provided in the attached “Schedule of Items” in strict accordance with the terms of this solicitation, and to provide the appropriate insurance and bonds if this offer is accepted by the Government in writing.

As Offeror also agrees:

First: To do any extra work, not covered by the attached “Schedule of Items”, which may be ordered by the Resident, and to accept as full compensation the amount determined upon a “Force Account” basis as provided in the Standard Specifications, November 2014 Edition, and as addressed in the contract documents.

Second: That the bid bond at 5% of the bid amount or the official bank check, cashier’s check, certificate of deposit or U. S. Postal Money Order in the amount given in the “Notice to Contractors”, payable to the Treasurer of the State of Maine and accompanying this bid, shall be forfeited, as liquidated damages, if in case this bid is accepted, and the undersigned shall fail to abide by the terms and conditions of the offer and fail to furnish satisfactory insurance and Contract bonds under the conditions stipulated in the Specifications within 15 days of notice of intent to award the contract.

Third: To begin the Work as stated in Section 107.2 of the Standard Specifications November 2014 Edition and complete the Work within the time limits given in the Special Provisions of this Contract.

Fourth: That this offer shall remain open for 30 calendar days after the date of opening of bids.

Fifth: The Bidder hereby certifies, to the best of its knowledge and belief that: the Bidder has not, either directly or indirectly, entered into any agreement, participated in any collusion, or otherwise taken any action in restraint of competitive bidding in connection with its bid, and its subsequent contract with the Department.

IN WITNESS WHEREOF, the Contractor, for itself, its successors and assigns, hereby execute two duplicate originals of this Agreement and thereby binds itself to all covenants, terms, and obligations contained in the Contract Documents.

CONTRACTOR

Date

(Signature of Legally Authorized Representative
of the Contractor)

Witness

(Name and Title Printed)

G. Award.

Your offer is hereby accepted.
documents referenced herein.

This award consummates the Contract, and the

MAINE DEPARTMENT OF TRANSPORTATION

Date

By: Bruce A. Van Note, Commissioner

Witness

CONTRACT AGREEMENT, OFFER & AWARD

AGREEMENT made on the date last signed below, by and between the State of Maine, acting through and by its Department of Transportation (Department), an agency of state government with its principal administrative offices located at Child Street, Augusta, Maine, with a mailing address at 16 State House Station, Augusta, Maine 04333-0016, and

_____ a corporation or other legal entity organized under the laws of the State of _____, with its principal place of business located at _____

The Department and the Contractor, in consideration of the mutual promises set forth in this Agreement (the "Contract"), hereby agree as follows:

A. The Work.

The Contractor agrees to complete all Work as specified or indicated in the Contract including Extra Work in conformity with the Contract, WIN **018964.00**, for the **Rolling Dam 2 Bridge Culvert Rehabilitation** in the city of **Gardiner**, County of **Kennebec**, Maine. The Work includes construction, maintenance during construction, warranty as provided in the Contract, and other incidental work.

The Contractor shall be responsible for furnishing all supervision, labor, equipment, tools supplies, permanent materials and temporary materials required to perform the Work including construction quality control including inspection, testing and documentation, all required documentation at the conclusion of the project, warranting its work and performing all other work indicated in the Contract.

The Department shall have the right to alter the nature and extent of the Work as provided in the Contract; payment to be made as provided in the same.

B. Time.

The Contractor agrees to complete all Work, except warranty work, on or before **April 24, 2020**. Further, the Department may deduct from moneys otherwise due the Contractor, not as a penalty, but as Liquidated Damages in accordance with Sections 107.7 and 107.8 of the *State of Maine Department of Transportation Standard Specifications, November 2014 Edition* and related Special Provisions.

C. Price.

The quantities given in the Schedule of Items of the Bid Package will be used as the basis for determining the original Contract amount and for determining the amounts of the required Performance Surety Bond and Payment Surety Bond, and that the amount of this offer is _____

\$_____ Performance Bond and Payment Bond each being 100% of the amount of this Contract.

D. Contract.

This Contract, which may be amended, modified, or supplemented in writing only, consists of the Contract documents as defined in the Plans, Standard Specifications, November 2014 Edition, Standard Details November 2014 Edition as updated through advertisement, Supplemental Specifications, Special Provisions, Contract Agreement; and Contract Bonds. It is agreed and understood that this Contract will be governed by the documents listed above.

E. Certifications.

By signing below, the Contractor hereby certifies that to the best of the Contractor's knowledge and belief:

1. All of the statements, representations, covenants, and/or certifications required or set forth in the Bid and the Bid Documents, including those in the Contract are still complete and accurate as of the date of this Agreement.
2. The Contractor knows of no legal, contractual, or financial impediment to entering into this Contract.
3. The person signing below is legally authorized by the Contractor to sign this Contract on behalf of the Contractor and to legally bind the Contractor to the terms of the Contract.

F. Offer.

The undersigned, having carefully examined the site of work, the Plans, Standard Specifications November 2014 Edition, Standard Details November 2014 Edition as updated through advertisement, Supplemental Specifications, Special Provisions, Contract Agreement; and Contract Bonds contained herein for construction of: **WIN 018964.00 Rolling Dam 2 Bridge Culvert Rehabilitation plus other incidental work**, State of Maine, on which bids will be received until the time specified in the “Notice to Contractors” do(es) hereby bid and offer to enter into this contract to supply all the materials, tools, equipment and labor to construct the whole of the Work in strict accordance with the terms and conditions of this Contract at the unit prices in the attached “Schedule of Items”.

The Offeror agrees to perform the work required at the price specified above and in accordance with the bids provided in the attached “Schedule of Items” in strict accordance with the terms of this solicitation, and to provide the appropriate insurance and bonds if this offer is accepted by the Government in writing.

As Offeror also agrees:

First: To do any extra work, not covered by the attached “Schedule of Items”, which may be ordered by the Resident, and to accept as full compensation the amount determined upon a “Force Account” basis as provided in the Standard Specifications, November 2014 Edition, and as addressed in the contract documents.

Second: That the bid bond at 5% of the bid amount or the official bank check, cashier’s check, certificate of deposit or U. S. Postal Money Order in the amount given in the “Notice to Contractors”, payable to the Treasurer of the State of Maine and accompanying this bid, shall be forfeited, as liquidated damages, if in case this bid is accepted, and the undersigned shall fail to abide by the terms and conditions of the offer and fail to furnish satisfactory insurance and Contract bonds under the conditions stipulated in the Specifications within 15 days of notice of intent to award the contract.

Third: To begin the Work as stated in Section 107.2 of the Standard Specifications November 2014 Edition and complete the Work within the time limits given in the Special Provisions of this Contract.

Fourth: That this offer shall remain open for 30 calendar days after the date of opening of bids.

Fifth: The Bidder hereby certifies, to the best of its knowledge and belief that: the Bidder has not, either directly or indirectly, entered into any agreement, participated in any collusion, or otherwise taken any action in restraint of competitive bidding in connection with its bid, and its subsequent contract with the Department.

IN WITNESS WHEREOF, the Contractor, for itself, its successors and assigns, hereby execute two duplicate originals of this Agreement and thereby binds itself to all covenants, terms, and obligations contained in the Contract Documents.

CONTRACTOR

Date

(Signature of Legally Authorized Representative
of the Contractor)

Witness

(Name and Title Printed)

G. Award.

Your offer is hereby accepted.
documents referenced herein.

This award consummates the Contract, and the

MAINE DEPARTMENT OF TRANSPORTATION

Date

By: Bruce A. Van Note, Commissioner

Witness

CONTRACT AGREEMENT, OFFER & AWARD

AGREEMENT made on the date last signed below, by and between the State of Maine, acting through and by its Department of Transportation (Department), an agency of state government with its principal administrative offices located at Child Street Augusta, Maine, with a mailing address at 16 State House Station, Augusta, Maine 04333-0016, and (Name of the firm bidding the job) a corporation or other legal entity organized under the laws of the State of Maine, with its principal place of business located at (address of the firm bidding the job)

The Department and the Contractor, in consideration of the mutual promises set forth in this Agreement (the "Contract"), hereby agree as follows:

A. The Work.

The Contractor agrees to complete all Work as specified or indicated in the Contract including Extra Work in conformity with the Contract, PIN No. 1224.00, for the Hot Mix Asphalt Overlay in the town/city of South Nowhere, County of Washington, Maine. The Work includes construction, maintenance during construction, warranty as provided in the Contract, and other incidental work.

The Contractor shall be responsible for furnishing all supervision, labor, equipment, tools supplies, permanent materials and temporary materials required to perform the Work including construction quality control including inspection, testing and documentation, all required documentation at the conclusion of the project, warranting its work and performing all other work indicated in the Contract.

The Department shall have the right to alter the nature and extent of the Work as provided in the Contract; payment to be made as provided in the same.

B. Time.

The Contractor agrees to complete all Work, except warranty work, on or before November 15, 2006. Further, the Department may deduct from moneys otherwise due the Contractor, not as a penalty, but as Liquidated Damages in accordance with Sections 107.7 and 107.8 of the State of Maine Department of Transportation Standard Specifications, November 2014 Edition and related Special Provisions.

C. Price.

The quantities given in the Schedule of Items of the Bid Package will be used as the basis for determining the original Contract amount and for determining the amounts of the required Performance Surety Bond and Payment Surety Bond, and that the amount of this offer is (Place bid here in alphabetical form such as One Hundred and Two dollars and 10 cents)
\$ (repeat bid here in numerical terms, such as \$102.10) Performance Bond and Payment Bond each being 100% of the amount of this Contract.

D. Contract.

This Contract, which may be amended, modified, or supplemented in writing only, consists of the Contract documents as defined in the Plans, Standard Specifications, November 2014 Edition, Standard Details November 2014 Edition, Supplemental Specifications, Special Provisions, Contract Agreement, and Contract Bonds. It is agreed and understood that this Contract will be governed by the documents listed above.

E. Certifications.

By signing below, the Contractor hereby certifies that to the best of the Contractor's knowledge and belief:

1. All of the statements, representations, covenants, and/or certifications required or set forth in the Bid and the Bid Documents, including those in Appendix A to Division 100 of the Standard Specifications November 2014 Edition (Federal Contract Provisions Supplement), and the Contract are still complete and accurate as of the date of this Agreement.
2. The Contractor knows of no legal, contractual, or financial impediment to entering into this Contract.
3. The person signing below is legally authorized by the Contractor to sign this Contract on behalf of the Contractor and to legally bind the Contractor to the terms of the Contract.

F. Offer.

The undersigned, having carefully examined the site of work, the Plans, Standard Specifications, November 2014 Edition, Standard Details November 2014 Edition, Supplemental Specifications, Special Provisions, Contract Agreement; and Contract Bonds contained herein for construction of:

PIN 1234.00 South Nowhere, Hot Mix Asphalt Overlay,

State of Maine, on which bids will be received until the time specified in the "Notice to Contractors" do(es) hereby bid and offer to enter into this contract to supply all the materials, tools, equipment and labor to construct the whole of the Work in strict accordance with the terms and conditions of this Contract at the unit prices in the attached "Schedule of Items".

The Offeror agrees to perform the work required at the price specified above and in accordance with the bids provided in the attached "Schedule of Items" in strict accordance with the terms of this solicitation, and to provide the appropriate insurance and bonds if this offer is accepted by the Government in writing.

As Offeror also agrees:

First: To do any extra work, not covered by the attached "Schedule of Items", which may be ordered by the Resident, and to accept as full compensation the amount determined upon a "Force Account" basis as provided in the Standard Specifications, November 2014 Edition, and as addressed in the contract documents.

Second: That the bid bond at 5% of the bid amount or the official bank check, cashier's check, certificate of deposit or U. S. Postal Money Order in the amount given in the "Notice to Contractors", payable to the Treasurer of the State of Maine and accompanying this bid, shall be forfeited, as liquidated damages, if in case this bid is accepted, and the undersigned shall fail to abide by the terms and conditions of the offer and fail to furnish satisfactory insurance and Contract bonds under the conditions stipulated in the Specifications within 15 days of notice of intent to award the contract.

Third: To begin the Work as stated in Section 107.2 of the Standard Specifications November 2014 Edition and complete the Work within the time limits given in the Special Provisions of this Contract.

Fourth: The Contractor will be bound to the Disadvantaged Business Enterprise (DBE) Requirements contained in the attached Notice (Additional Instructions to Bidders) and submit a completed Contractor's Disadvantaged Business Enterprise Utilization Plan with their bid.

Fifth: That this offer shall remain open for 30 calendar days after the date of opening of bids.

Sixth: The Bidder hereby certifies, to the best of its knowledge and belief that: the Bidder has not, either directly or indirectly, entered into any agreement, participated in any collusion, or otherwise taken any action in restraint of competitive bidding in connection with its bid, and its subsequent contract with the Department.

IN WITNESS WHEREOF, the Contractor, for itself, its successors and assigns, hereby execute two duplicate originals of this Agreement and thereby binds itself to all covenants, terms, and obligations contained in the Contract Documents.

Date

(Witness Sign Here)
Witness

(Sign Here)
(Signature of Legally Authorized Representative of the Contractor)

(Print Name Here)
(Name and Title Printed)

CONTRACTOR

G. Award.

Your offer is hereby accepted. documents referenced herein.

This award consummates the Contract, and the

MAINE DEPARTMENT OF TRANSPORTATION

Date

By: Bruce A. Van Note, Commissioner

(Witness)

BOND # _____

CONTRACT PERFORMANCE BOND
(Surety Company Form)

KNOW ALL MEN BY THESE PRESENTS: That _____
_____ in the State of _____, as principal,
and.....
a corporation duly organized under the laws of the State of and having a
usual place of business
as Surety, are held and firmly bound unto the Treasurer of the State of Maine in the sum
of _____ and 00/100 Dollars (\$ _____),
to be paid said Treasurer of the State of Maine or his successors in office, for which
payment well and truly to be made, Principal and Surety bind themselves, their heirs,
executors and administrators, successors and assigns, jointly and severally by these
presents.

The condition of this obligation is such that if the Principal designated as Contractor in
the Contract to construct Project Number _____ in the Municipality of
_____ promptly and faithfully performs the Contract, then this
obligation shall be null and void; otherwise it shall remain in full force and effect.

The Surety hereby waives notice of any alteration or extension of time made by the State
of Maine.

Signed and sealed this day of, 20.....

WITNESSES:

SIGNATURES:

CONTRACTOR:

Signature.....

.....

Print Name Legibly

Print Name Legibly

SURETY:

Signature

.....

Print Name Legibly

Print Name Legibly

SURETY ADDRESS:

NAME OF LOCAL AGENCY:

.....
.....
.....

ADDRESS
.....
.....

TELEPHONE.....

.....

BOND # _____

CONTRACT PAYMENT BOND
(Surety Company Form)

KNOW ALL MEN BY THESE PRESENTS: That _____
_____ **in the State of** _____, as principal,
and.....
a corporation duly organized under the laws of the State of and having a
usual place of business in
as Surety, are held and firmly bound unto the Treasurer of the State of Maine for the use
and benefit of claimants as herein below defined, in the sum of
_____ **and 00/100 Dollars (\$** _____ **)**
for the payment whereof Principal and Surety bind themselves, their heirs, executors and
administrators, successors and assigns, jointly and severally by these presents.

The condition of this obligation is such that if the Principal designated as Contractor in
the Contract to construct Project Number _____ in the Municipality of
_____ promptly satisfies all claims and demands incurred for all
labor and material, used or required by him in connection with the work contemplated by
said Contract, and fully reimburses the obligee for all outlay and expense which the
obligee may incur in making good any default of said Principal, then this obligation shall
be null and void; otherwise it shall remain in full force and effect.

A claimant is defined as one having a direct contract with the Principal or with a
Subcontractor of the Principal for labor, material or both, used or reasonably required for
use in the performance of the contract.

Signed and sealed this day of, 20

WITNESS:

SIGNATURES:

CONTRACTOR:

Signature.....

.....

Print Name Legibly

Print Name Legibly

SURETY:

Signature.....

.....

Print Name Legibly

Print Name Legibly

SURETY ADDRESS:

NAME OF LOCAL AGENCY:

.....

ADDRESS

.....

.....

TELEPHONE

.....

BRIDGE NO. 6023

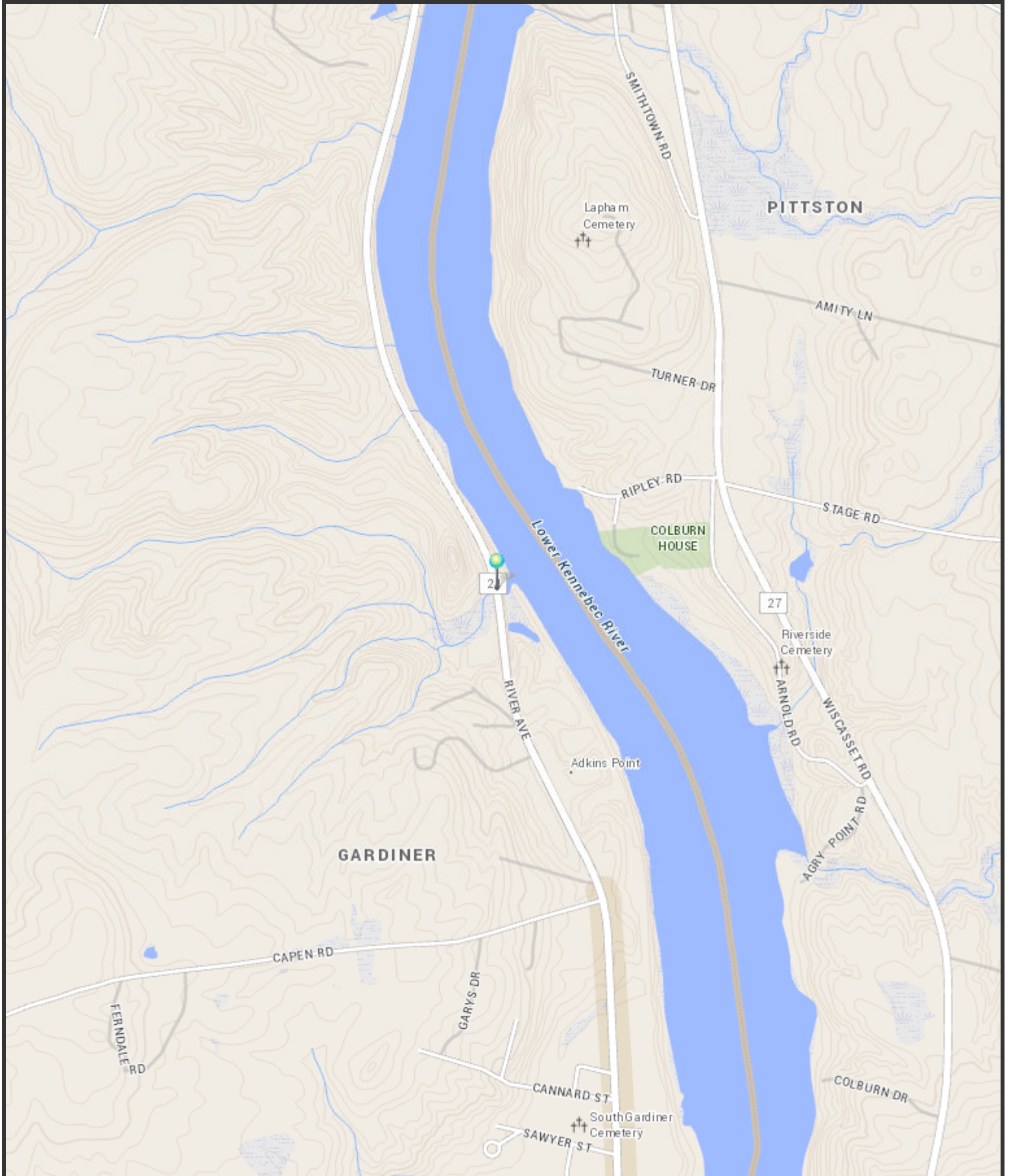

The Maine Department of Transportation provides this publication for information only. Reliance upon this information is at user risk. It is subject to revision and may be incomplete depending upon changing conditions. The Department assumes no liability if injuries or damages result from this information. This map is not intended to support emergency dispatch.

0.25 Miles
1 inch = 0.28 miles

Date: 5/29/2019
Time: 8:01:19 AM
29

**State of Maine
Department of Labor
Bureau of Labor Standards
Augusta, Maine 04333-0045
Telephone (207) 623-7906**

Wage Determination - In accordance with 26 MRS §1301 et. seq., this is a determination by the Bureau of Labor Standards, of the fair minimum wage rate to be paid to laborers and workers employed on the below titled project.

Title of Project -----Gardiner-Rolling Dam 2 Bridge Culvert Rehabilitation

Location of Project --Gardiner, Kennebec County

**2019 Fair Minimum Wage Rates
Heavy & Bridge Kennebec County**

<u>Occupation Title</u>	<u>Minimum Wage</u>	<u>Minimum Benefit</u>	<u>Total</u>	<u>Occupation Title</u>	<u>Minimum Wage</u>	<u>Minimum Benefit</u>	<u>Total</u>
Backhoe Loader Operator	\$26.48	\$4.96	\$31.44	Laborer - Skilled	\$19.50	\$5.72	\$25.22
Boilermaker	\$24.00	\$9.00	\$33.00	Line Erector - Power/Cable	\$31.00	\$5.49	\$36.49
Bulldozer Operator	\$20.00	\$3.71	\$23.71	Loader Operator - Front-End	\$21.50	\$3.17	\$24.67
Carpenter	\$23.50	\$4.16	\$27.66	Mechanic- Maintenance	\$22.25	\$3.97	\$26.22
Carpenter - Rough	\$22.00	\$7.20	\$29.20	Mechanic- Refrigeration	\$25.71	\$5.09	\$30.80
Communication Equip Installer	\$23.00	\$1.63	\$24.63	Millwright	\$25.10	\$9.55	\$34.65
Comm Transmission Erector	\$20.13	\$3.83	\$23.96	Painter	\$19.50	\$3.58	\$23.08
Concrete Mixing Plant Operator	\$22.11	\$4.92	\$27.03	Paver Operator	\$20.00	\$0.00	\$20.00
Crane Operator =>15 Tons)	\$27.00	\$6.79	\$33.79	Pipe/Steam/Sprinkler Fitter	\$27.00	\$5.61	\$32.61
Crusher Plant Operator	\$17.38	\$3.12	\$20.50	Pipelayer	\$23.00	\$1.14	\$24.14
Diver	\$32.00	\$6.91	\$38.91	Plumber (Licensed)	\$25.00	\$4.26	\$29.26
Driller - Well	\$19.83	\$2.66	\$22.49	Plumber Helper/Trainee	\$19.00	\$3.10	\$22.10
Earth Auger Operator	\$25.84	\$5.78	\$31.62	Rigger	\$22.50	\$6.57	\$29.07
Electrician - Licensed	\$29.25	\$9.44	\$38.69	Roller Operator - Earth	\$22.11	\$2.77	\$24.88
Electrician Helper/Cable Puller	\$18.00	\$3.38	\$21.38	Roller Operator - Pavement	\$19.00	\$1.06	\$20.06
Excavator Operator	\$24.00	\$2.91	\$26.91	Sheet Metal Worker	\$20.00	\$4.11	\$24.11
Fence Setter	\$15.00	\$2.00	\$17.00	Stone Mason	\$21.00	\$0.95	\$21.95
Flagger	\$13.00	\$0.00	\$13.00	Truck Driver - Light	\$17.00	\$1.17	\$18.17
Ironworker - Reinforcing	\$28.71	\$0.00	\$28.71	Truck Driver - Medium	\$19.00	\$3.37	\$22.37
Ironworker - Structural	\$20.50	\$2.50	\$23.00	Truck Driver - Heavy	\$18.50	\$2.06	\$20.56
Laborers (Helpers & Tenders)	\$17.00	\$1.38	\$18.38	Truck Driver - Tractor Trailer	\$21.13	\$4.07	\$25.20

The Laborer classifications include a wide range of work duties. Therefore, if any specific occupation to be employed on this project is not listed in this determination, call the Bureau of Labor Standards at the above number for further clarification.

Welders are classified in the trade to which the welding is incidental.

Apprentices - The minimum wage rate for registered apprentices are those set forth in the standards and policies of the Maine State Apprenticeship and Training Council for approved apprenticeship programs.

Posting of Schedule - Posting of this schedule is required in accordance with 26 MRS §1301 et. seq., by any contractor holding a State contract for construction valued at \$50,000 or more and any subcontractors to such a contractor.

Appeal - Any person affected by the determination of these rates may appeal to the Commissioner of Labor by filing a written notice with the Commissioner stating the specific grounds of the objection within ten (10) days from the filing of these rates.

Determination No: HB-015-2019

A true copy

Filing Date: June 3, 2019

Attest: 

Expiration Date: 12-31-2019

Scott R. Cotnoir
Wage & Hour Director
Bureau of Labor Standards

BLS(Heavy & Bridge Kennebec)

SPECIAL PROVISIONS
SECTION 104
Utilities

UTILITY COORDINATION

The contractor has primary responsibility for coordinating their work with utilities after contract award. The contractor shall communicate directly with the utilities regarding any utility work necessary to maintain the contractor’s schedule and prevent project construction delays. The contractor shall notify the resident of any issues. The Contractor shall plan and conduct his work accordingly.

MEETING

A Preconstruction Utility Conference, as defined in Subsection 104.4.6 of the Standard Specifications is required.

GENERAL INFORMATION

These Special Provisions outline the arrangements that have been made by the Department for utility and/or railroad work to be undertaken in conjunction with this project. The following list identifies all known utilities or railroads having facilities presently located within the limits of this project or intending to install facilities during project construction.

Utilities have been notified and will be furnished a project specification.

Utility/Railroad	Aboveground	Underground
Central Maine Power	X	
Time Warner Cable	X	
Gardiner Wastewater District		X
Gardiner Water District		X

Utility working days are Monday through Friday. Times are estimated on the basis of a single crew for each utility. Any times and dates mentioned are **estimates only** and are dependent upon favorable weather, working conditions, and freedom from emergencies. The Contractor shall have no claim against the Department if they are exceeded.

If the **Contractor** feels temporary relocation is necessary they must notify the **Department** of their concerns prior to bid.

In all cases, the utilities shall be notified, by the Contractor, well in advance (two weeks) before work in any area is to commence.

The Contractor shall plan and schedule their work in such a manner that the utilities that are located on this project will not be harmed, damaged or impacted in any way. The Contractor and Utility will coordinate and communicate their work plans in an effort not to interfere with each other's progress or the completion of the project. The Contractor must give the utilities at least 2 weeks' prior notification on when the utilities may start their work. If this communication breaks down, then the Contractor shall notify the Utility Coordinator.

AERIAL

No Aerial distribution cable adjustments are anticipated as part of this project. No pole relocation is anticipated. The bidding Contractors are encouraged to visit the site, prior to bid, and review all above ground wires, safety offsets for electrical three phase and choose their construction methods accordingly. Depending on the method of construction the Contractor may be working next to, or under the existing wires. These lines must stay energized, so the Contractor is encouraged to visit the site, prior to bid, to determine how to construct safely. Temporary utility adjustments are not anticipated. If temporary relocation becomes necessary, the Contractor shall notify the affected Utility Companies. Any cost for temporary relocations shall be the responsibility of the Contractor. The Contractor shall not have any claims against the department if the existing lines become a construction issue. Sufficient time will need to be allowed prior to the construction for all required temporary relocation.

SUBSURFACE

The **City of Gardiner** has sewer facilities upstream of the culvert and within the project limits. These facilities consist of a flow control structure, siphon inlet box and outlet boxes as well as a 30-inch concrete gravity sewer line approximately 10-foot under the stream bed. It appears the scope of the work will not impact this facility and the Contractor shall take care while working around their line not to disrupt or damage. If the scope of the work changes for any reason and conflicts could be possible the Contractor shall immediately contact the City for marking of their system.

The system also includes a 24" overflow discharge pipe that is located near the existing culvert inlet. This overflow serves as emergency discharge for when severe storms occur or in case treatment plant failure occurs. This system has not activated, for a storm, since 2012 and the plant has not failed since it was built in 1982.

With the ability of this pipe discharging into the work zone, the Contractor will develop a Safety Plan for actions and notifications needed in the event of a possible release. The Contractor will work collaboratively with the City in developing this safety plan. This Plan will be discussed and drafted at the pre-construction meeting and when finalized, given to the Resident. Payment for this Safety Plan will be considered incidental to the invert lining. The Contractor shall monitor the weather and stay in touch with the City when cofferdams are in place.

If in the unlikely event that a discharge occurs during construction and damage occurs because of this discharge, the Resident and Contractor will work collaboratively with the City of

Town: **Gardiner**
Road Name: **Route 24**
Project: **WIN 18964.00**
Date: **Oct 24, 2017**

Gardiner regarding a repair course of action. The Contractor shall plan and schedule their work in such a manner that the utilities that are located on this project will not be harmed, damaged or impacted in any way. The contact for the City of Gardiner is Doug Clark at 582-1351.

The **Gardiner Water District** has a water main in the project. It appears the scope of the work will not impact this facility and the Contractor shall take care while working around their line to not disrupt or damage it. If the scope of the work changes for any reason, and conflicts could be possible, the Contractor shall immediately contact the District for guidance. The Contractor shall plan and schedule his work in such a manner that the utilities that are located on this project will not be harmed, damaged or impacted in any way. The contact for the Gardiner Water District is Paul Gray at 623-582-5500.

UTILITY SIGNING

The Contractor shall ensure that the traveling public is adequately protected at all times from any Utility Company working within the construction limits of this project. All work areas shall be signed, lighted, and traffic flaggers employed as determined by field conditions. All traffic controls shall be in accordance with the latest edition of the Manual on Uniform Traffic Control Devices for Streets and Highways, as issued by the Federal Highway Administration.

SAFE PRACTICES AROUND UTILITY FACILITIES

The Contractor shall be responsible for complying with M.R.S.A. Title 35-A, Chapter 7-A Sections 751 -761 Overhead High-Voltage Line Safety Act. Prior to commencing any work that may come within ten (10) feet of any aerial electrical line; the Contractor shall notify the aerial utilities as per section 757 of the above act.

DIG SAFE

The Contractor shall be responsible for determining the presence of underground utility facilities prior to commencing any excavation work and shall notify Utilities of proposed excavation in accordance with M.R.S.A. Title 23 §3360-A, Maine “Dig Safe” System. The Contractor is also reminded that all Utilities on the project may not be members of Dig Safe.

MAINTAINING UTILITY LOCATION MARKINGS

The Contractor will be responsible for maintaining the buried utility location markings following the initial locating by the appropriate utility or their designated representative.

Town: **Gardiner**
Road Name: **Route 24**
Project: **WIN 18964.00**
Date: **Oct 24, 2017**

The following utilities are known to be located on this project:

<u>Utility Companies</u>	<u>Utility Contact</u>	<u>Phone</u>
Central Maine Power Company	Skip McKay	207-626-9445
Fairpoint	Marty Pease	207-797-1119
Gardiner Water District	Paul Gray	207-582-5500
Gardiner Waste Water District	Doug Clark	207-582-1351

**SPECIAL PROVISION
SECTION 104
GENERAL RIGHTS & RESPONSIBILITIES
(Bridge Closure Notification)**

Section 104, General Rights and Responsibilities, of the Standard Specifications is amended as follows:

104.4.10 Coordination of Bridge Closure/Bridge Width Restriction Notification:

Paragraph 2 is removed and replaced with the following:

A public notice shall be published in a local newspaper ten day prior to the closure.

SPECIAL PROVISION
SECTION 105
General Scope of Work
(Environmental Requirements)

In-Water work consists of any activity conducted below the normal high water mark of a river, stream, brook, lake, pond or “Coastal Wetland” areas that are subject to tidal action during the highest tide level for the year which an activity is proposed as identified in the tide tables published by the National Ocean Service. <http://www.oceanservice.noaa.gov/> For the full definition of “Coastal Wetlands”, please refer to 38 MRSA 480-B(2)

I. In-Water Work shall not be allowed between the dates of April 10 and September 30.
(In-Water work is allowed from October 1 to April 9.)

II. In-Water work window applies to the following water bodies at the following station #'s:

1. Rolling Dam Brook at proposed culvert rehabilitation

III. Special Conditions:

1. Special Conditions of Army Corps of Engineers (ACOE) Category II permit apply (see permit and conditions in contract documents).
2. Special Conditions of Formal Endangered Species Act (Section 7) Consultation with National Marine Fisheries Service apply (summarized in this Special Provision 105).
3. The contractor shall hold a pre-construction meeting for each project with appropriate MaineDOT Environmental Office staff, other MaineDOT staff, and the MaineDOT construction crew or contractor(s) to review all procedures and requirements for avoiding and minimizing effects to Atlantic salmon and Sturgeon and to emphasize the importance of these measures for protecting these species and their habitat. ACOE (Jay Clement, Jay.I.clement@usace.army.mil) and National Marine Fisheries Service staff (Dan Tierney, dan.tierney@noaa.gov) shall be invited to attend these meetings.
4. All work below the Ordinary High-Water Line (upstream of culvert) and Highest Annual Tide line (downstream of culvert) shall be completed within a cofferdam.
5. In-water work for installation and removal of the downstream cofferdam shall be done starting 3 hours prior to published low tide until 3 hours after published low tide and may happen over a several day period.
6. For all work utilizing pumps, the contractor shall use pump intake screens designed to insure approach velocity does not exceed 0.20 foot/second (6.10 cm/s) preventing entrainment of any small fish during dewatering and temporary stream rerouting around active construction. Square or round screen face openings are not to exceed 3/32 inches (2.38 mm) measured on a diagonal. Criteria for slotted face openings shall not exceed 1/16 inches (approximately 1.75 mm) in the narrow direction. Intake hoses shall be regularly monitored while pumping.
7. All cofferdams shall be removed from the stream immediately following completion of construction, allowing for minor delays due to high stream flows following heavy precipitation, so that fish and other aquatic organism passage is not unnecessarily restricted.
8. All areas of temporary waterways or wetland fill shall be restored to their original contour and character upon completion of the project.

9. Disturbed areas adjacent to the waterway shall be stabilized and re-vegetated with a seed mix appropriate for riparian areas in Maine.
10. The Contractor shall follow measures designed to avoid and minimize effects to streams from hazardous materials associated with construction activities. These measures include the following:
 - a. All vehicle refueling shall occur more than 100 feet from any water course.
 - b. All vehicles carrying fuel shall have specific equipment and materials needed to contain or clean up any incidental spills at the project site. Equipment and materials would include spill kits appropriately sized for specific quantities of fuel, shovels, absorbent pads, straw bales, containment structures and liners, and/or booms.
 - c. During use, all pumps and generators shall have appropriate spill containment structures and/or absorbent pads in place.
 - d. All equipment used for in-stream work shall be cleaned of external oil, grease, dirt, and mud. Any leaks or accumulations of these materials would be corrected before entering streams or areas that drain directly to streams or wetlands.
11. To minimize the spread of noxious weeds into the riparian zone, all off-road equipment and vehicles must be inspected and cleaned prior to entering the construction site to remove all soil, seeds, vegetation or other debris that could contain seeds or reproductive portions of plants.

IV. Approvals:

1. Temporary Soil Erosion and Water Pollution Control Plan
2. Permitted Resource Impacts (square feet), see ACOE permit for locations:

Stream:

Permanent: RUS- 750

Temporary RUS-1300

V. All activities are prohibited (including placement and removal of cofferdams unless otherwise permitted by Regulatory Agencies) below the normal high water mark if outside the prescribed in-water work window, except for the following:

1. Work within a cofferdam constructed according to MaineDOT's Standard Specifications and in adherence with the contractors approved "Soil Erosion and Water Pollution Control Plan".

VI. No work is allowed that completely blocks a river, stream, or brook without providing downstream flow.

NOTE: Regulatory Review and Approval is required to modify the existing In-Water work window. Requests for work window extensions must be submitted to the MaineDOT Environmental Office. Approvals of requests for work window extensions are not guaranteed and may result in delays in construction schedule that are the sole responsibility of the contractor.

SPECIAL PROVISION
SECTION 105
GENERAL SCOPE OF WORK
Traffic Control

The following is added to the Standard Specifications in accordance with Subsection 105.3
Traffic Control and Management:

The Contractor, at a minimum, shall maintain one 11 foot wide lane in each direction utilizing lane shifts. Overnight lane closures shall not be allowed. Lane closures with alternating traffic shall only be allowed if approved by the Resident.

Gardiner
Rolling Dam 2 Bridge
WIN 018964.00
May 23, 2019

SPECIAL PROVISION
SECTION 107
TIME

The specified Contract Completion Date is April 24, 2020.

SPECIAL PROVISION
SECTION 109.5
ADJUSTMENTS FOR DELAY
(Delays due to Flooding)

109.5.1 Definitions - Types of Delays

Delete Paragraph 'A' in its entirety and replace with:

A. Excusable Delay Except as expressly provided otherwise by this Contract, an "Excusable Delay" is a Delay to the Critical Path that is directly and solely caused by: (1) a weather related Event of such an unusually severe nature that a Federal Emergency Disaster is declared. The Contractor will only be entitled to an adjustment of time if the Project falls within the geographic boundaries prescribed under the disaster declaration, or (2) a flooding event at the effected location of the Project that results in a headwater elevation of 17.5 feet (NAVD88), or greater, but less than a Q50 headwater elevation. Theoretical headwater elevations will be determined by the Department; actual headwater elevations will be determined by the Contractor and verified by the Department.

SPECIAL PROVISION
SECTION 203
EXCAVATION AND EMBANKMENT
(Dredge Material)

Management and Disposal: Dredge Material (See MaineDOT Standard Specifications § 101.2 Definitions) is regulated as a Special Waste.

In accordance with MRSA 418, Dredge Material shall be managed as a Special Waste. Work associated with the Gardiner Pipe Invert Lining initiative will require the excavation of select Dredge Material from the waterbody. It is anticipated that approximately 65 cubic yards of Dredge Material will be excavated. There is no place to reuse this dredge at the project site. This Dredge Material shall be disposed of at an appropriately licensed facility.

The Contractor shall dispose of Dredge Material from the project at a facility licensed by the Maine Department of Environmental Protection (MDEP) for the management of Special Waste. The Contractor shall be responsible for making all necessary arrangements for dewatering and proper management of the Dredge Material, including any laboratory testing, in accordance with the facility's license. The Contractor shall provide documentation to the Resident that the Dredge Material was managed as specified. The submitted documentation shall consist of truck manifests, waybills, or such documentation as may be acceptable to the Resident and shall clearly document the management site location and the quantity of Dredge Material.

It is acknowledged that the excavation of Dredge for this work may include some boulders. The Maine Department of Environmental Protection (MDEP) has determined that sound boulders (rock 12-inches or more in diameter), that are free of adhering sediment or other contaminants, shall be deemed to be Inert Fill material and shall not be included in the Dredge Material Quantities.

Method of Measurement: Dredge Material will be measured by the cubic yard of material removed. Special Waste properly disposed of will be measured by the ton.

Basis of Payment: Payment for the Beneficial Use of Dredge Material will be incidental to the project.

The accepted quantity of Dredge Material properly disposed of, as Special Waste, will be paid for at the contract unit price bid for Disposal of Special Waste.

Payment shall be full compensation for excavation, dewatering, testing, managing, transporting, disposal or placement, and all associated fees.

Payment will be made under:

<u>Pay Item</u>		<u>Pay Unit</u>
203.2318	Disposal of Special Waste	Ton

SPECIAL PROVISION
SECTION 502
STRUCTURAL CONCRETE
(Cast-in-place Invert Lining)

Description This work shall include preparation of existing surfaces, installation of studs, spot painting of corroded areas, placement of concrete, and the application of emulsified asphalt.

The Contractor has the option of using either a shotcrete lining method or a composite lining method for the culvert repair in lieu of this cast in place method. If the Contractor chooses a shotcrete or composite method, the appropriate Special Provision must be followed.

Materials Concrete for the culvert repair shall be Class "A" Concrete. The concrete mix shall include a chemical accelerator and shall be submitted to the Resident for prior approval.

Construction Requirements All work shall be in conformity with applicable requirements of Section 502.

Welded concrete anchor studs shall be installed in accordance with Section 505 of the Standard Specifications with the following changes. Subsections 505.04 and 505.051 are removed, and the first paragraph of Section 505.05 is replaced with the following:

Studs shall be inspected for a full 360-degree weld. Any stud that is found not to have the full weld shall be marked for re-welding.

All reinforcement shall be secured in place to prevent displacement during the concrete placement.

Finish the entire length of the concrete invert with a broom surface finish.

The horizontal interfaces (joint between the top of the concrete invert lining and the corrugated metal culvert) shall be sealed with an asphalt emulsion (roofing tar) which extends onto the metal culvert at least 1 inch.

All areas of steel section loss above the concrete liner shall be sandblasted and painted with a Moisture-Cured Zinc Primer and a Moisture-Cured Urethane Coal Tar Topcoat.

The Contractor shall sandblast all areas from 1 inch below the top of concrete lining to 6 inches below the lowest row of shear connectors. The Contractor shall remove all loose materials, rust, scale, oil and deleterious material from all remaining surfaces to receive concrete by methods acceptable to the Resident. In areas where the metal is non-existent, a preliminary concrete placement shall be made to fill voids and establish the former extremity lines of the metal, utilizing forms where required. The final placement is to be made over this preliminary placement. No concrete shall be placed on frozen surfaces.

Concrete shall not be placed without cold weather protection when the ambient temperature is below 40° F. Cold weather protection shall include heating under tents, blankets, or other means acceptable to the Resident. The temperature of the concrete, when deposited, shall be above 50° F but less than 90° F. The concrete temperature shall be maintained at a minimum temperature of 50° F for a minimum of 7 days.

Concrete application shall also be suspended during high winds and heavy rains when, in the opinion of the Resident, the quality of the application is not acceptable. Newly placed concrete exposed to rain that washes out cement or otherwise makes the concrete unacceptable to the Resident shall be removed and replaced. The Contractor shall provide adequately secured polyethylene sheeting or equivalent when adverse exposure to weather is anticipated.

An approved curing cover (or compound) shall be applied within 18 hours after finishing. Finished concrete shall be cured for a minimum of 48 hours before flushed with water, unless otherwise directed by the Resident, and flush water must be collected as per Section 656.

Method of Measurement The structural concrete for the culvert invert lining, satisfactorily placed and accepted in accordance with the dimensions shown on the plans, will be measured as one lump sum unit.

Basis of Payment The accepted structural concrete for the culvert invert lining will be paid for at the Contract lump sum price for Structural Concrete Culvert Invert Lining. The contract lump sum price shall be full compensation for preparing surfaces, installing studs, spot painting of corroded areas above the concrete, placing concrete, applying asphalt emulsion, and furnishing all materials, equipment, labor, and incidentals necessary to complete the work. Reinforcing steel fabrication, delivery and placing shall be paid for under their respective pay items.

Concrete admixtures including silica fume will not be paid for directly, but shall be incidental to the related contract item.

The containment and disposal of pollutants during surface preparation will not be paid for directly but shall be incidental to the related contract item and included in the Contractor's Soil Erosion and Water Pollution Control Plan.

Payment will be made under:

<u>Pay Item</u>	<u>Pay Unit</u>
502.325 Structural Concrete Culvert Invert Lining	Lump Sum

SPECIAL PROVISION
SECTION 502
STRUCTURAL CONCRETE
(Shotcrete Culvert Invert Lining)

Description This work shall include preparation of existing surfaces, installation of studs, spot painting of corroded areas, application by pneumatic pressure of a shotcrete mix, furnishing test panels, extracting cores, and application of asphalt emulsion as indicated on the Plans, and in accordance with this specification.

The Contractor has the option of using either a cast-in-place lining method or a composite lining method for the culvert repair in lieu of this shotcrete method. If the Contractor chooses a cast-in-place or composite method, the appropriate Special Provision must be followed.

Shotcrete shall conform to all requirements of ACI 506.2 “Specifications for Materials, Proportioning, and Application of Shotcrete”, published by the American Concrete Institute, Detroit, Michigan, except as modified by the requirements of this project specification. Shotcrete shall consist of an application of one or more layers of mortar or concrete conveyed through a hose and pneumatically projected at a high velocity against a prepared surface.

Shotcrete shall be produced by either a dry-mix or a wet-mix process. The wet-mix process consists of thoroughly mixing all of the ingredients except accelerating admixtures, but including the mixing water, introducing the mixture into the delivery equipment and delivering it, by positive displacement, to the nozzle. The wet-mix shotcrete shall then be air jetted from the nozzle at high velocity onto the surface. The dry-mix process is shotcrete without mixing water which is conveyed through the hose pneumatically and the mixing water is introduced at the nozzle. For additional descriptive information, see the American Concrete Institute “Guide to Shotcrete” (ACI 506R).

Qualifications The work shall be performed by fully qualified personnel experienced in this type of work.

1. The foreman shall have at least five years of shotcrete experience and at least two years as a nozzleman.
2. The nozzleman shall have at least two years recent experience of satisfactory work as a nozzleman.
3. Evidence of the foreman and nozzleman’s experience of satisfactory work in similar capacities elsewhere shall be provided.

Materials All materials for shotcrete shall conform to the following requirements.

Cement	AASHTO M-85, ASTM C150, Type I, II, III or IV
Fine Aggregate	AASHTO M-6, ASTM C33 clean, natural
Coarse Aggregate	AASHTO M-80, Class B for quality

Water	Potable, clean, and free from substances deleterious to concrete and steel or elements that would stain
Chemical Admixtures	ASTM C1141 and the following:
Water-reducer	AASHTO M-194, Type A, D, F, G or
Superplasticizer	ASTM C494 Type A, D, F, G
Air-Entraining Agent	AASHTO M-194/ASTM C260
Plasticizers	AASHTO M-194 Type A, D, F, G or ASTM C494
Mineral Admixtures	
Fly Ash	AASHTO M-295, ASTM C618 Type F or C
Silica Fume	ASTM C1240, 90% minimum silicon dioxide solids content, not to exceed 12% by weight of cement. In addition, silica fume shall conform to the requirements of Section 502.
Polypropylene Fibers	ACI Standard, Polypropylene Fibers, 1 inch in length, 1½ lb/yd ³
Steel Fibers	ASTM A820 Type I, II, or III, Deformed, Steel Fibers, 1 inch to 1 ⅜ inches in length, minimum aspect ratio of 60
Curing Compounds	ASTM C309 Type 1-D or Type 2
Pre-packaged Shotcrete	ASTM C928

Other admixtures shall not be used unless approved by the Resident. Admixtures used to entrain air, to reduce water-cement ratio, to retard or accelerate setting time, or to accelerate the development of strength shall be thoroughly mixed into the shotcrete at the rate specified by the manufacturer unless specified otherwise. Accelerating additives shall be compatible with the cement used, be non-corrosive to steel, and shall not promote other detrimental effects such as cracking or excessive shrinkage. The maximum allowable chloride ion content of all ingredients shall not exceed 0.10% when tested to AASHTO T260.

Premixed and pre-packaged concrete products specifically manufactured as a shotcrete product may be provided for on-site mixed shotcrete if approved by the Resident. The packages shall contain materials conforming to the materials portion of this specification.

Welded concrete anchor studs shall be installed in accordance with Section 505 of the Standard Specifications with the following changes: Subsections 505.04 and 505.051 are removed, and the first paragraph of Section 505.05 is replaced with the following:
Studs shall be inspected for a full 360-degree weld. Any stud that is found not to have the full weld shall be marked for re-welding.

Materials Storage and Handling Materials shall be delivered, stored, and handled to prevent contamination, segregation, corrosion, or damage. Liquid admixtures shall be stored to prevent evaporation and freezing.

Cement shall be adequately stored to prevent moisture degradation and partial hydration. Cement that has become caked or lumpy shall not be used.

Aggregates shall be stored so that segregation and the inclusion of foreign materials are prevented. The bottom 6 inches of aggregate piles in contact with the ground shall not be used.

Submittals The following submittals shall be provided by the Contractor for the Resident's review and approval. The Contractor will not be allowed to begin culvert repairs until all submittal requirements are satisfied and found acceptable to the Resident. Changes or deviations from the approved submittals must be resubmitted for approval. Adjustments in contract time will not be allowed for incomplete submittals.

At least 21 calendar days prior to initiating the work, the Contractor shall submit to the Resident the following:

1. Written documentation of the foreman's and nozzleman's qualifications and the proposed method of shotcrete placement.
2. Shotcrete mix design including:
 - a) Brand and type of Portland Cement used
 - b) Source, gradation, and quality of aggregates as specified herein
 - c) Proportions of mix by weight
 - d) Proposed admixtures, manufacturer, dosage, and technical literature (when admixture allowed)
 - e) Compressive strength test results from the manufacturer's records, no older than six months, verifying the 28-day compressive strength

Shotcrete Mix Design Aggregate for shotcrete shall meet the strength and durability requirement of AASHTO M-80 and M-43 and shall meet the following gradation requirements.

<u>Sieve Size</u>	<u>% Passing by Weight</u>
3/8 in	100
No. 4	95 – 100
No. 8	80 – 100
No. 16	50 – 85
No. 30	25– 60
No. 50	10 – 30
No. 100	2 – 10
No. 200	0-5
FM	2.3 to 3.1

- A. Proportioning Shotcrete shall be proportioned and delivered with a minimum cement content of 650 lb/yd³.
- B. Strength Requirements Shotcrete shall be proportioned to produce a mix capable of attaining 5,000 psi compressive strength in 28 days. The average compressive strength of each set of three cores extracted from the test panels shall equal or exceed the specified

compressive strength, with no individual core less than 75 percent of the specified compressive strength, in accordance with ACI 506.2.

Mixing and Batching Mixing equipment shall be capable of thoroughly mixing the materials in sufficient quantity to maintain the placing continuity. Shotcrete shall be batched, delivered, and placed within 90 minutes of mixing.

Field Quality Control Production test panels are required. Qualified personnel shall perform shotcreting and coring of the test panels with the Department's personnel present. The Contractor shall provide equipment, materials, and personnel as necessary to obtain shotcrete cores for testing including construction of test panel boxes, field curing requirements, and coring. The Department will perform compressive strength testing. Shotcrete final acceptance will be based on obtaining the specified 28-day compressive strength.

Shotcrete core samples failing to meet the minimum specified 28-day compressive strength shall be evaluated per section 502.195 Pay Adjustment Method C of the Standard Specifications using the pay reductions for Class LP Compressive Strength in Table 6, Method C Pay Reductions, if allowed by the Department to remain in place.

Shotcreting may commence upon initial approval of the design mix and nozzlemen.

Production Test Panels At least one production test panel shall be furnished during each day of production of shotcrete. The production test panels shall be constructed simultaneously with the shotcrete facing installation at times designated by the Resident. Production test panels shall be made with the minimum dimensions of 18 x 18 inches and at least 6 inches thick.

Test Panel Curing, Test Specimen Extraction, and Testing Immediately after shooting, the test panels shall be field moist cured by covering and tightly wrapping with a sheet of material meeting the requirements of ASTM C 171 until delivered to the testing lab or test specimens are extracted. The test panels shall not be immersed in water. The test panels shall not be disturbed for the first 24 hours after shooting.

At least three, 3-inch diameter core samples shall be cut from each unreinforced production test panel for compressive strength testing. The Contractor shall extract the test specimens from test panels in the field within 48 hours of shooting the panel. The panels shall be kept in their forms when transported.

Cores shall not be taken from the outer 6 inches of test panels measured in from the outside edges of the panel's form.

The cores and container shall be clearly marked to identify the core locations. For production testing, the production section of the unformed superstructure repair represented by the production test panel cores shall be marked on the cores and the container. Immediately wrap cores in wet burlap or material in accordance with the requirements of ASTM C 171 and seal in a plastic bag. The Department shall take possession of the cores immediately after extraction.

The remainder of the panels shall become the property of the Contractor. The Department will perform the compressive strength testing.

Upon delivery to the testing lab, samples will be placed in the moist room until the time of test. When the test length of a core is less than twice the diameter, the correction factors given in AASHTO T 24/ASTM C 42 will be applied to obtain the compressive strength of individual cores. Three cores will be tested at 28 days for compressive strength per AASHTO T 24/ASTM C 42.

Construction Requirements

The construction sequence shall be in accordance with the approved submittal, unless otherwise approved by the Resident.

A. Equipment

1. The shotcreting equipment selected must be capable of metering the mix through a hose to the nozzle for projecting at high velocity onto the surface to be shotcreted.
2. The gun shall be either the double chamber or the rotary type capable of continuous delivery of material. Gaskets in the equipment must be kept in good condition to avoid reduced pressure and consequent reduced velocity of material through the hose.
3. The air compressor may be any standard type capable of sufficient pressures and volume of air to convey the material through the longest hose delivery. The air compressor capacity must have allowance for air used in removing rebound and other incidental work. The air hose shall be equipped with filters to prevent any oil or grease from contaminating the shotcrete.
4. Water pressure shall be maintained at a minimum 15 psi higher than the highest air pressure required for placing the material. Both air and water pressure shall be uniformly steady.

B. Surface Preparation The Contractor shall remove all loose materials, rust, scale, oil, and deleterious material from all surfaces to receive shotcrete by methods acceptable to the Resident. The removal shall be accomplished in such a manner as not to loosen, crack, or shatter the surfaces to receive the shotcrete. Any surface material, which in the opinion of the Resident is so loosened or damaged, shall be removed to a sufficient depth to provide a base that is suitable to receive the shotcrete. The Contractor shall clean all surfaces to receive shotcrete by methods acceptable to the Resident. Material that loosens as the shotcrete is applied shall be removed. No shotcrete shall be placed on frozen surfaces.

All areas of section loss above the concrete liner shall be sandblasted and painted with a Moisture-Cured Zinc Primer and a Moisture-Cured Urethane Coal Tar Topcoat.

- C. Shotcrete Alignment Control The Contractor shall ensure that the thickness of shotcrete satisfies the minimum thickness shown on the design drawings using alignment wires, thickness control pins, or other means acceptable to the Resident.
- D. Delivery and Application In areas of the culvert where the metal is non-existent and voids are present, a preliminary placement of shotcrete shall be made to fill all voids and establish the former extremity lines of the structure face. The final placement is to be made over this preliminary placement to full depth.

The shotcrete shall be applied from the lower part of the work area upwards to prevent accumulation of rebound on uncovered surfaces. Rebound shall not be worked back into the placement nor shall the rebound be salvaged. Rebound which does not fall clear of the working area shall be removed. The nozzle shall be held at an angle approximately perpendicular to the working face and at a distance so that rebound will be minimal and compaction will be maximized. Thickness, methods of support, air pressure, and rate of placement of shotcrete shall be controlled to prevent sagging or sloughing of freshly applied shotcrete.

The shotcreting procedure may be corrected by adjusting the nozzle distance and orientation perpendicular to the surface, adjusting the water content of the shotcrete mix, or other means acceptable to the Resident. Retempering of the mix will not be permitted. The shotcreted surface shall be broomed and roughened to insure proper bond of subsequent layers.

All horizontal edges of exposed concrete (joint between the top of the concrete invert lining and the corrugated metal culvert) shall be sealed with an asphalt emulsion which extends onto the culvert at least 1 inch.

- E. Defective Shotcrete Surface defects shall be repaired as soon as possible after initial placement of the shotcrete. All shotcrete that lacks uniformity; exhibits segregation, sagging, honeycombing, or lamination; or contains any voids or sand pockets shall be removed and replaced with fresh shotcrete by the Contractor in accordance with this specification and to the satisfaction of the Resident.

A clearly defined pattern of continuous horizontal or vertical ridges or depressions at the reinforcing elements after they are covered will be considered an indication of insufficient cover of reinforcement or poor application and probable voids. In this case, the application of shotcrete shall be immediately suspended and the work carefully inspected by the Resident. The Contractor shall implement and complete corrective measures prior to resuming the shotcrete operations.

- F. Reinforcement All reinforcement shall be secured in place to prevent displacement during the shotcrete application.

- G. Finish Shotcrete finish shall be a natural gun finish. Scraping or cutting to remove high spots shall not be done until the shotcrete has become stiff enough to withstand the pull of the cutting device.
- H. Weather Limitations Shotcrete shall not be placed without cold weather protection when the ambient temperature is below 40° F and falling and/or when the shotcrete is likely to be subjected to freezing temperatures before a minimum strength of 700 psi. Cold weather protection shall be maintained until the strength of the in-place shotcrete is greater than 750 psi. Cold weather protection shall include heating under tents, blankets, or other means acceptable to the Resident. The temperature of the shotcrete, when deposited, shall be above 50° F but less than 90° F.

Shotcrete application shall also be suspended during high winds and heavy rains when, in the opinion of the Resident, the quality of the application is not acceptable. Newly placed shotcrete exposed to rain that washes out cement or otherwise makes the shotcrete unacceptable to the Resident shall be removed and replaced. The Contractor shall provide adequately secured polyethylene sheeting or equivalent when adverse exposure to weather is anticipated.

- I. Curing An approved curing cover (or compound) shall be applied within 18 hours after finishing. After surface water has evaporated from the finished surface, shotcrete exposed to sunlight shall be immediately treated for curing. Finished shotcrete shall be cured for a minimum of 48 hours before flushed with water, unless otherwise directed by the Resident, and flush water must be collected per Section 656.

Safety Requirements Appropriate eye and dust protection equipment shall be used during shotcrete application. Cement and other admixtures are caustic and may cause eye, skin, and respiratory irritation unless safety measures are taken. Adequate ventilation shall be required. Nozzlemen and helpers shall at a minimum be equipped with gloves, respirators, eye protection and adequate protective clothing during the application of shotcrete. The Contractor is responsible for meeting all Federal, State, and Local Safety Code Requirements.

Method of Measurement The shotcrete for the culvert invert lining, satisfactorily applied and accepted in accordance with the dimensions shown on the Plans, will be measured as one lump sum unit.

Basis of Payment The accepted shotcrete for the culvert invert lining will be paid for at the contract lump sum price for Structural Concrete Culvert Invert Lining. The Contract lump sum price shall be full compensation for preparing surfaces, installing studs, spot painting of corroded areas above the concrete, applying shotcrete, applying asphalt emulsion, constructing test panels, extracting cores, and furnishing all materials, equipment, labor, and incidentals necessary to complete the work. Reinforcing steel fabrication, delivery, and placing shall be paid for under their respective pay items.

Shotcrete admixtures including silica fume will not be paid for directly, but shall be incidental to the related contract item.

The containment and disposal of pollutants during surface preparation and during shotcrete application will not be paid for directly, but shall be incidental to the related contract item and included in the Contractor's Soil Erosion and Water Pollution Control Plan.

Payment will be made under:

<u>Pay Item</u>	<u>Pay Unit</u>
502.325 Structural Concrete Culvert Invert Lining	Lump Sum

SPECIAL PROVISION
SECTION 502
STRUCTURAL CULVERT
(Composite Invert Lining)

Description This specification covers the rehabilitation (invert lining) of and fish weirs (where applicable) for culvert structures through the use of glass fiber reinforced polymer (FRP) liner segments.

The Contractor has the option of using either a shotcrete lining method or a cast-in-place lining method for the culvert repair in lieu of this composites method. If the Contractor chooses a shotcrete or cast-in-place method, the appropriate Special Provision must be followed.

DEFINITIONS

For the purpose of this specification, the following definitions apply:

E-glass	Alumo-borosilicate glass with an alkali content of maximum one weight percent, when expressed as sodium oxide (Na ₂ O)
Effective length of unit	The distance between planes normal to the unit axis and passing through the end points of the lining unit
Liner segment	A discrete length of culvert lining which may be either a single pipe lining unit or a combined pair of segmental lining units
Vinyl ester resin	A resin produced by the esterification of an epoxy resin with an unsaturated monocarboxylic acid – the reaction product is then dissolved in a reactive solvent, such as styrene, to a 35 - 50 percent content by weight

MATERIALS

Glass Mat A layer of E-glass fiber constructed as either chopped strand mat (CSM) or continuous filament mat (CFM) that provides a resin rich FRP layer near the corrosion/erosion exposed surface. All glass fiber reinforcement shall have a surface treatment (binder) compatible with the lining manufacturing process and the matrix resins. A stitched material laminate is also acceptable.

Glass fiber Reinforcement All glass fiber reinforcement shall be E-glass or better and have a surface treatment compatible with the lining manufacturing process and the matrix resins. Unidirectional (UD) reinforcement areal weight shall not exceed 55 oz/yd² in any single ply. A layer of CSM or CFM shall separate layers of UD fabric where applicable to maintain laminar shear strength. The E-glass material shall not contain more than 0.2% moisture by weight as supplied; it shall be uncontaminated and protected to the point of use.

Grout Grout having a 28-day compressive strength of at least 4,000 psi at the desired water content for optimum placement shall be used. The permissible mixing and placement temperature range per the manufacturer's recommendations shall not be lower than 40°F or

higher than 90°F. The non-shrink grout shall have a Hardened Height Change per ASTM C1090 of 0.0 to 0.3%.

Resin Vinyl ester or vinyl ester blend corrosion resistant resin shall be used with a catalysis process applied in accordance with the resin manufacturer's instructions. The resin shall have a viscosity suitable for the manufacturing method. The gel time shall be adequate for the given environmental conditions present during the manufacturing process. The gel time must allow for the elimination of wedging within the part. Resin promotion should allow for adequate cure during manufacture. Resin must achieve a minimum of 80% of manufacturer's Barcol value without post curing.

Cured resins, as cast singly without reinforcement, shall have an elongation at break greater than 1.4% when tested in accordance with ASTM D790. In addition, the Barcol Hardness as determined by ASTM D2503 shall be at least 30. Resins with added flexibility through the addition of plasticizers shall not be used.

Coating Dyes, pigments, or additives shall be introduced as necessary in the resin to provide resistance to ultra-violet light degradation and a uniform, muted appearance.

Fasteners Carbon steel fasteners and washers with a minimum 0.2 mil zinc coating or stainless steel fasteners and washers shall be used. Fasteners shall have a minimum shank diameter of 0.138 inches and washers shall have a diameter of between ¾ to 1 inch.

CONSTRUCTION REQUIREMENTS

General All culvert linings shall be manufactured with the following elements:

- A corrosion and abrasion resistant barrier layer
- A reinforcement layer comprised of double bias and unidirectional fabric
- A rough backing to provide a bond between the lining and annular grout
- A nailing flange that is offset from the general liner radius

The manufacturing facility shall have a Certified Composites Technician (CCT) certified in Open Molding or Vacuum Infusion Process (VIP) on staff to supervise or perform the manufacturing of all composite components. The design of the composite liner shall be completed by a composites engineer and be verified by a Professional Engineer.

Barrier Layer (BL) The BL shall be manufactured from a vinyl ester resin system reinforced with E-glass CSM or CFM between 30-50% content by weight. The BL shall be a minimum of 0.10 inches thick.

Glass reinforcement The structural layer shall be made from a vinyl ester resin system impregnated layers of E-glass fiber. At least one ply shall be double bias (± 45) stitched or woven fabric having an areal weight of at least 24 oz/yd². At least one ply shall be made up of unidirectional (UD) E-glass with the fiber direction oriented in the circumferential (hoop)

direction of the liner. The areal weight of the UD plies shall be selected by analysis and/or tested to satisfy strength and stiffness requirements. The structural layer shall have a fiber content of between 50%-70% by weight.

Liner fabrication Each fabric layer comprising the FRP liner shall be placed in a mold having the same nominal inner radius as the culvert minus 1 inch to avoid contact with the culvert bolts. A nailing flange shall transition outward to the nominal inner radius of the culvert extending a minimum of 2 times the number of fastener rows plus 1 inch. A gradual transition shall exist between the two liner radii extending between 3 to 6 inches depending on liner radius. The extent of the liner in the circumferential dimension shall be as shown on the Plans.

Rough backing A clean, dry aggregate shall be bonded to the back of the FRP liner to promote a mechanical bond between the liner and grout filler. It shall consist of an angular, inert material, such as crushed granite, nominally 1/8 to 1/4 inch in size uniformly distributed over the external surface. A CSM layer with an areal weight at least 1.5 oz/ft² shall be hand laid on to the back of the liner using a vinyl ester resin system and rollers to provide a resin-rich embedment layer for the aggregate. Once the resin has cured, a stiff broom shall be passed over the surface to remove any loose or poorly bonded aggregate. The aggregate must uniformly cover 50% or more of the total surface area of the back of the panel.

Weir Fabrication Weirs shall be fabricated from E-glass fabric and a vinyl ester resin system using the materials described above. The size, shape, and elevation of the weir features shall be as shown on the Plans. Wall thickness shall be at least 1/2 inch. Wall thickness may need to increase based on panel radius. Allowable stresses as per RTP1-2011.

Edges and ends The edges and ends of all trimmed lining segments and sections shall be sealed with a vinyl ester resin system to prevent the exposure of glass fibers. The resin shall be pigmented to match the color and performance of the laminating resin.

INSTALLATION

General

Flow Diversion Flow shall be rerouted or dammed prior to culvert cleaning and until after the liner, grout, and weirs have been installed. The presence of some groundwater is acceptable as long as flow is prevented along the length of the culvert. Any water propagating through the corroded invert of the culvert must be contained prior to panel installation. No grout dilution is allowable.

Cleaning and Preparation Debris shall be removed from the culvert and disposed of in accordance with state and local environmental requirements. The invert shall be pressure washed to remove soil and loose, corroded material from the culvert. All debris should be removed by mechanical means. Any holes in the steel culvert shall be sealed with hydraulic cement. Bolts that protrude more than 1.25 inches above the crest of corrugations shall be

trimmed prior to placing the FRP liner. Bolts should be cut off flush with the top of the nut. The nut must not be compromised.

All areas of culvert section loss above the composite liner shall be sandblasted and painted with a Moisture-Cured Zinc Primer and a Moisture-Cured Urethane Coal Tar Topcoat.

LINERS

Attachment The exact position of the first liner segment placed at one end of the culvert shall be determined based on the segment length and the overall length of the culvert such that the first and last liner segments shall be at least 5 feet long.

Liner segments shall be secured to sound steel using powder-actuated galvanized or stainless steel fasteners. The frequency and spacing of the fasteners shall be determined by engineering analysis of the seam strength requirements. Fasteners shall be driven with enough energy to ensure the head and washer are seated tight against the FRP and that contact is maintained between the FRP and steel while avoiding excess force that may cause cupping of the washer or damage to the FRP. Jacking poles may be used to hold the FRP against the steel in places where sudden geometry changes prevent contact under dead weight. The allowance of any gap between the FRP and steel is at the discretion of the engineer and shall be minimized.

Trimming Liner segments placed at the culvert ends shall be trimmed to match the taper of the existing steel culvert. The ends shall be sealed with a mixture of resin and fiber to contain the annular grout. The edges and ends of all trimmed lining segments and sections shall be sealed with a vinyl ester resin system to prevent the exposure of glass fibers. The resin shall be pigmented to match the color and performance of the laminating resin.

Joining All joining of panels shall be designed as per RTP1-2011 standards and specifications. Reference sections 3A-800 Secondary Bond Shear Stress and subpart 3B Design by Stress Analysis sections 3B-100 through 3B-700 to determine proper joint design. Refer to RTP1-2011 Mandatory Appendix M-5 Qualification of Laminators and Secondary Bonders for the required standards and practices. See section M-5 for required procedures to properly manufacture and test shear bond strength specimens.

FISH WEIRS

Size and Location The number, size, geometry, and location/elevation of all fish weirs internal and external shall be as shown on the plans.

Fitting Each fish weir shall be fabricated oversized and trimmed to fit in the required location. All trimmed edges shall be treated in accordance with the Construction Requirements above. The final weir channel elevation of the trimmed part shall be verified by the Resident prior to attachment.

Attachment The internal weirs shall be attached to the liner through the use of a methacrylate adhesive capable of bridging a gap of at least 0.250". The weir must be 100% edge sealed with the adhesive. The adhesive must be allowed to completely cure prior to installing the final weld kit. The final weld kit shall be installed on the upstream side of the weir and across the top seams on both sides. The weld kit shall be in accordance with ASME RTP-1 specifications. Glass used shall be E-glass and consist of a combination of 1.5 oz CSM and 24 oz Woven Roving. All weld kits must be final coated and leave no exposed areas.

External Fish Weirs External fish weirs should be pre-assembled on a jig and placed as a complete unit in the prepared location. The Site should be excavated to a depth as shown on the Plans to allow for the installation of a Geotextile stabilization fabric followed by a minimum of 12" of ¾" stone. The entire stone bed must be leveled to within ¼" prior to placement. The top of the stone must allow for the critical surfaces of the weirs and spouts to be at the proper final elevation.

Forming of the weirs must allow for the complete encapsulation of the weirs and spouts. Installation and placement of rebar shall be in accordance with all plans and specifications. External edges must be softened to assure that there are no 90° drop offs.

QUALITY ASSURANCE

As part of the quality assurance procedures, the manufacturer shall keep records of the following against each batch of output product:

- raw material batch details, including source, acceptance test records, purchase dates and shelf-life at time of use
- resin mixing records
- initiator level
- mold pressure at commencement of infusion
- mold temperature
- resin temperature
- ambient temperature of the shop
- infusion start and stop time
- visual inspection results of the cured part
- final Barcol readings
- technician names and date of manufacture

Appearance and surface condition The surface of the lining material shall be free from tackiness and defects such as protruding fibers, air voids, crazes, cracks, blisters or foreign matter that might impair the performance in service. The internal surface of the lining shall be textured. The surface of the panels shall be finished with a pigmented UV resistant final coat. Pigment must be compatible with the resin system.

Joints The liner and joint shall be designed so that the resulting lap joint is flush with the interior surface of the liner segments. The flexible or rigid joints are required to provide a

permanent seal between liner segments to protect the integrity of the grout and prevent water ingress. Rigid setting or flexible compounds used to caulk or seal the gap between liner segments shall be resistant to the environment for which they are intended, and shall be suitable for installation within a confined space taking safety aspects into consideration. Upon complete cure of the sealing compound, the joint should be finished with a weld kit designed in accordance with ASME RTP-1 specifications and final coated.

Performance requirements A composites engineer shall determine the appropriate reinforcing ply thickness to satisfy all strength, stiffness, and seam strength requirements assuming the corroded invert does not provide any residual strength to the system. Mechanical testing performed by a certified (ISO 9000 or equivalent) testing laboratory shall be conducted to verify predicted material properties for final design and provide quality control data. All calculations supporting the design shall be submitted for approval by the Department prior to beginning construction.

Type tests Coupon tests to verify predicted mechanical properties used during preliminary design shall be performed before completing the detail design. These tests shall include flexural strength and modulus per ASTM D790 and compressive strength and modulus per ASTM D6641. Component level tests shall be performed to verify the predicted buckling strength of the FRP/grout system and the shear capacity of the connection. The acceptable design value for strength is the mean minus two standard deviations. The acceptable design value for modulus is the mean.

QUALITY CONTROL TESTS

General The following test requirements are necessary in order to demonstrate a continuing satisfactory level of production quality in day-to-day production. The manufacturer shall establish a quality system to meet the requirements of ISO 9001 or ASME RTP-1. Witness panels fabricated at the same time using the same materials as the liner or cut-outs from the liner segment shall be used to conduct verification tests for every tenth panel fabricated.

Dimensions Wall thickness and resin rich layer thickness shall be determined at a minimum of three locations in each test sample using a method of measurement accurate to the nearest 0.005 inches by measuring cut surfaces through the lining wall. The cut surfaces shall be smoothed sufficiently for the different layers to be delineated. Generally the locations of cores shall include:

- A point towards the center of the test sample and points near each end of the test sample, but not at a joint.

Resin cure The surfaces shall not be tacky to the touch. Each test specimen shall be tested in accordance with the method described in ASTM D2503 at a minimum of three points and shall have a hardness not less than the minimum declared in the material subsection for resin. Post curing is permissible if necessary to achieve the desired results.

Analysis of construction The disposition of the laminates or layers and the constituents within them shall correspond to those of the type tested liners. The percentage by weight of the constituents and the weight of glass per unit area shall not deviate from the declared control values by more than $\pm 10\%$ (of each numerical value).

Appearance The internal and external surfaces of each lining unit shall be examined visually and be free from defects. Where practicable, this shall occur prior to application of any bed mat backing or pigmented, UV resistant final surface coating.

Mechanical Properties The coupon tests described above under Type tests shall be conducted on test samples. The Quality Control Test results are acceptable if the calculated design values are not less than 95% of the Type Test values.

CONTROL OF TEST CONDITIONS

Test conditions Unless otherwise required by this specification, the test measurements shall be conducted at a temperature of $72 \pm 10^\circ\text{F}$ and relative humidity of $50 \pm 10\%$.

Specimen conditioning For Type Testing, specimens shall be kept in air $72 \pm 10^\circ\text{F}$ and $50 \pm 10\%$ relative humidity for not less than 72 hours prior to testing.

For Quality Control Testing, specimens shall be kept in air at $72 \pm 10^\circ\text{F}$ and $50 \pm 10\%$ relative humidity for not less than 24 hours after they are considered to be cured.

NOTE: The preferred temperature for conditioning and testing composite materials is 72°F and 50% relative humidity.

Test specimen preparation Test specimens shall be prepared in accordance with the applicable ASTM standards.

WORKMANSHIP, INSPECTION AND CERTIFICATION

Manufacturing Process FRP liners shall be manufactured using vacuum assisted resin transfer molding (VARTM) or open molding to ensure the production of high quality components and repeatability of physical and mechanical properties.

All raw materials shall be tested at a frequency sufficient to ensure consistency and compliance with this specification. The manufacturer shall adequately supervise all stages of production and keep records of the raw material batches used and products made each work shift or day. Manufacture shall be under environmental conditions compatible with producing satisfactory liners and raw materials shall be stored and used in compliance with the recommendations of their manufacturers.

Reinforcement materials shall be stored in dry conditions. The liner manufacturer shall be familiar with the changes in viscosity, gel times, etc., which may occur during storage of the

resin, and make appropriate allowances in the lining manufacturing process. Resin stored in original unopened containers shall not be used after the resin manufacturer's stated expiration date.

Inspection In addition to the manufacturer's own inspection and supervision, the Department shall have access at all reasonable times to inspect parts and all relevant test records.

Certification The manufacturer shall, on request, furnish the Department with copies of a signed certificate for each size of liner stating that the construction and testing of liner segments supplied comply with the requirements of this specification and given details of minimum performance parameters agreed with the Department. The quality control test results or a suitable summary shall be provided with the certificate.

PROTECTION OF LINING UNITS

Liner segments shall be handled, stored, and transported in such a way as to prevent damage before receipt by the purchaser.

METHOD OF MEASUREMENT

Composite invert lining and/or fish weirs satisfactorily placed and accepted in accordance with the dimensions shown on the plans will be measured as one lump sum unit.

BASIS OF PAYMENT

The accepted structural composite invert lining and/or composite fish weirs will be paid for at the Contract lump sum price under the related Structural Concrete Culvert Invert Lining and Structural Concrete Fish Weir items. The contract lump sum price shall be full compensation for preparing surfaces, spot painting of corroded areas above the composite lining, placing composite segments, and furnishing all other materials, equipment, labor, and incidentals necessary to complete the work.

The containment and disposal of pollutants during surface preparation will not be paid for directly, but shall be incidental to the related contract item and included in the Contractor's Soil Erosion and Water Pollution Control Plan.

Payment will be made under:

<u>Pay Items</u>	<u>Pay Unit</u>
502.325 Structural Concrete Culvert Invert Lining	Lump Sum

SPECIAL PROVISION
SECTION 502
STRUCTURAL CONCRETE
(Fish Weirs)

Description This work shall consist of forming and placing reinforced concrete fish weirs inside the culvert and any incidental construction in accordance with these specifications, as called for on the plans, or as designated by the Resident. All work shall be in conformity with the Standard Specifications and other Special Provisions.

Materials Concrete shall be Class A.

Composites may be used for the internal fish weirs and may be placed at the same time as the invert lining, upon the Resident's approval. If the fish weirs are made from composite material, the requirements of Special Provision Section 502 - Structural Culvert Invert Lining (Composite Invert Lining), shall be followed.

CONSTRUCTION REQUIREMENTS

General The fish weirs shall be formed, cast, and stripped in the conventional manner; the use of shotcrete will not be allowed for construction of the fish weirs.

Method of Measurement Reinforced concrete fish weirs satisfactorily placed and accepted will be measured for payment as one lump sum unit acceptably covered in accordance with the plans and this special provision.

Basis of Payment Reinforced concrete fish weirs will be paid for at the contract lump sum price. Payment shall be full compensation for forming, placing and finishing the concrete, and all equipment, labor, and other incidentals necessary to complete the work.

Payment will be made under:

Pay Item	Pay Unit
502.326 Structural Concrete Fish Weirs	Lump Sum

SPECIAL PROVISION
SECTION 502
STRUCTURAL CONCRETE
(QC/QA Acceptance Methods)

CLASS OF CONCRETE	ITEM NUMBER	DESCRIPTION	P	METHOD
A	All	All Class A concrete	-	C

SPECIAL PROVISION
SECTION 652
MAINTENANCE OF TRAFFIC

Approaches. Approach signing shall include the following signs at a minimum. Field conditions may warrant the use of additional signs as determined by the Resident..

Road Work Next X* Miles
Road Work 500 Feet (Ahead)
End Road Work

Work Areas. At each work site, signs and channelizing devices shall be used as directed by the Resident.

Signs include:

Road Work xxxx¹.
One Lane Road Ahead
Flagger Sign

Other typical signs include:

Be Prepared to Stop
Low Shoulder
Bump
Pavement Ends

The above lists of Approach signs and Work Area signs are representative of the contract requirements. Other sign legends may be required.

The Contractor shall conduct their operations in such a manner that the roadway will not be restricted to one lane for more than 2,500 feet at each work area. To encourage quality paving in warm-weather conditions, the length can be extended to 4,000 feet depending on the traffic impacts. Where more than one work area restricts traffic to one lane operation, these work areas shall be separated by at least 1 mile of two way operation.

Temporary Centerline A temporary centerline shall be placed each day on all new pavement to be used by traffic. The temporary centerline, when specified of reflectorized traffic paint, shall conform to the standard marking patterns used for permanent markings. Failure to apply a temporary centerline daily will result in a Traffic Control Violation and suspension of paving operations until temporary markers are applied to all previously placed pavement.

¹ “Road Work Ahead” to be used in short duration operations and “Road Work xx feet” to be used in stationary operations as directed by the Resident.

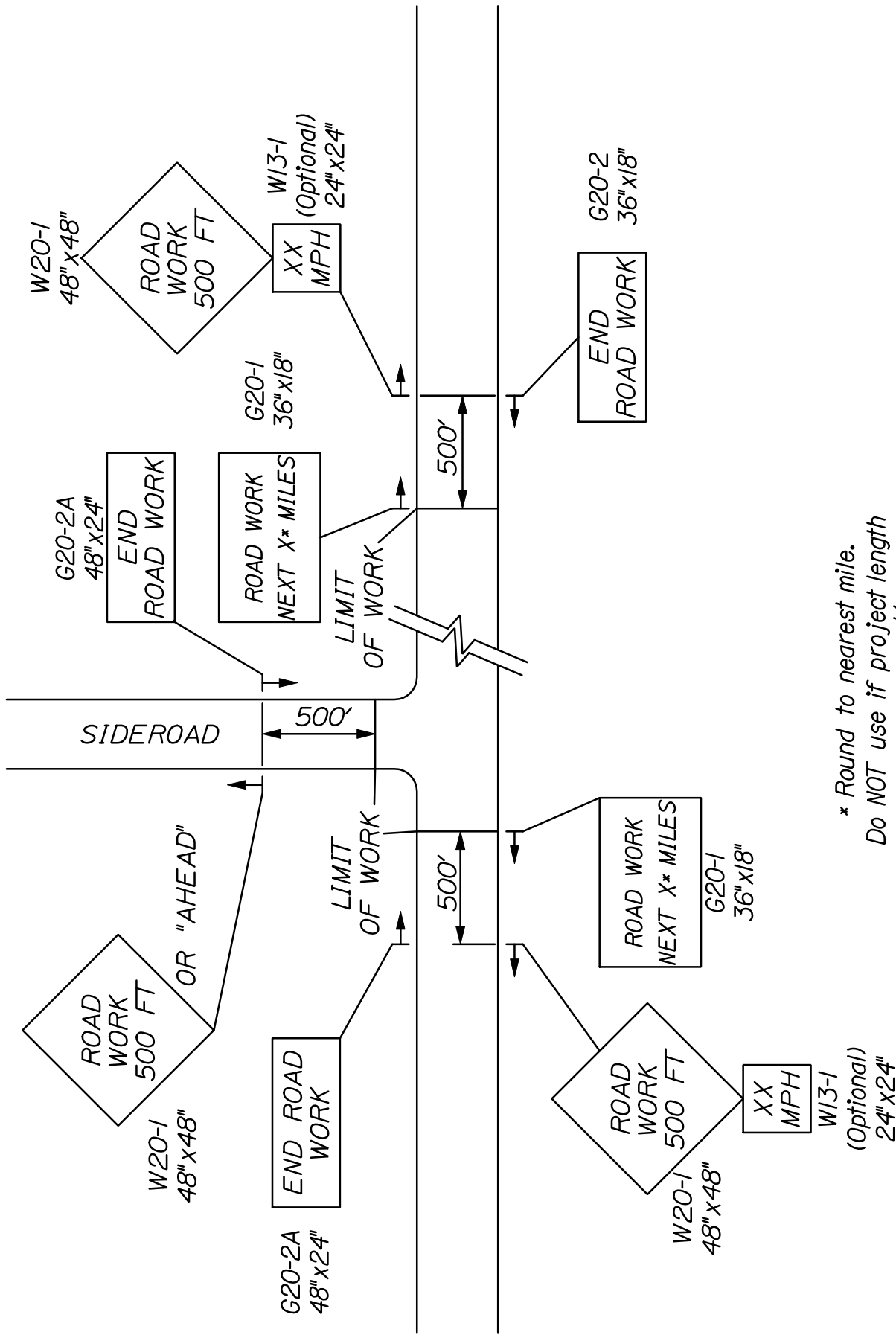

* Round to nearest mile.
 Do NOT use if project length
 is less than a 1 1/2 mile.

~ PROJECT APPROACH SIGNING ~
 TWO WAY TRAFFIC

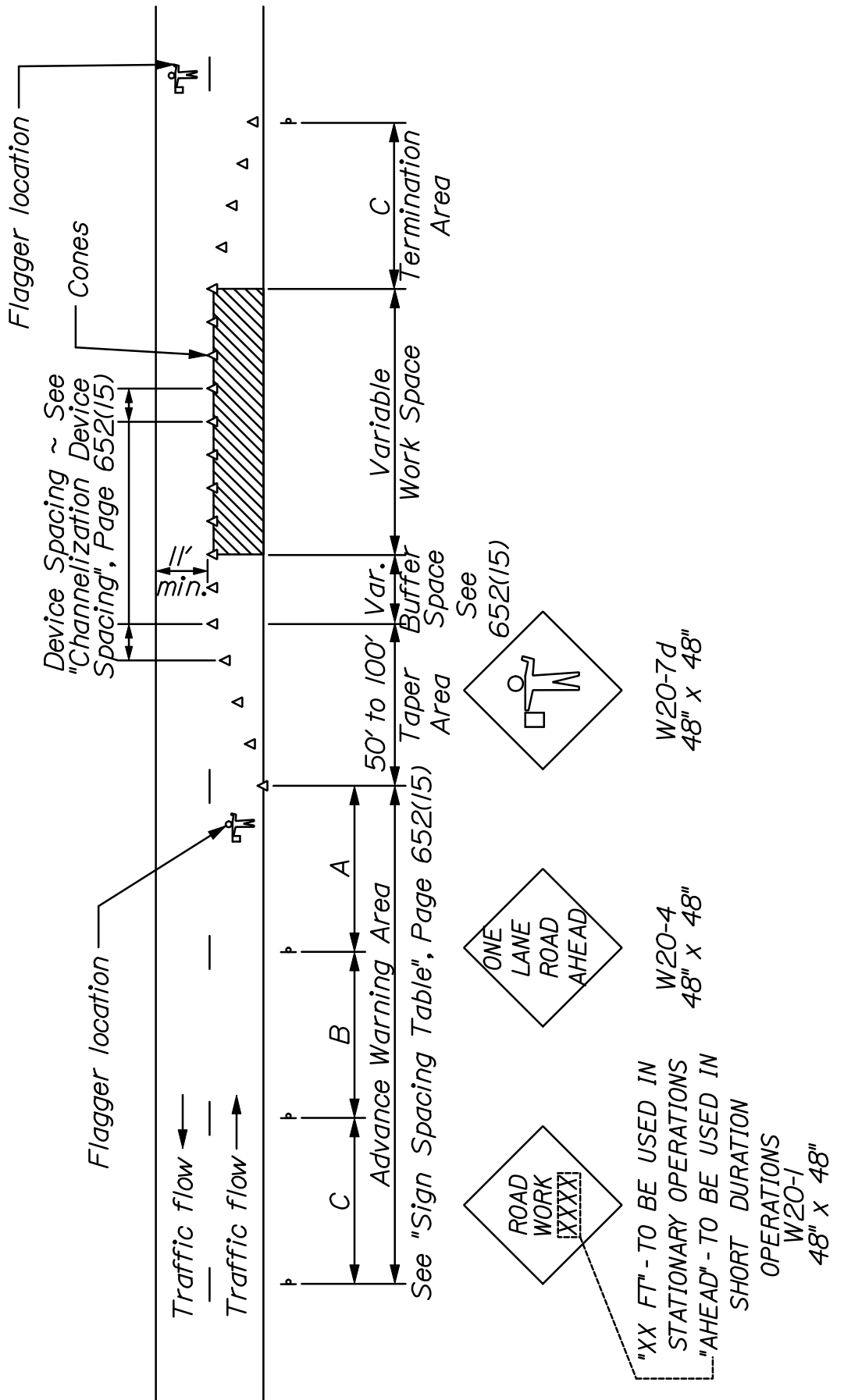

~ TYPICAL APPLICATION: TWO -WAY, TWO LANE ROADWAY,
 CLOSING ONE LANE USING FLAGGERS ~

* Formulas for L are as follows:
For speed limits of 40 mph or less:

$$L = \frac{WS^2}{60}$$

For speed limits of 45 mph or greater:

$$L = WS$$

* Formulas for L are as follows:

A minimum of 5 channelization devices shall be used in the taper.

TYPE OF TAPER	TAPER LENGTH (L)*
Merging Taper	at least L
Shifting Taper	at least 0.5 L
Shoulder Taper	at least 0.33 L
One-Lane, Two-Way Traffic Taper	100 ft maximum
Downstream Taper	100 ft per lane

CHANNELIZATION DEVICE SPACING

The spacing of channelization devices shall not exceed a distance in feet equal to 1.0 times the speed limit in mph when used for taper channelization, and a distance in feet of 2.0 times the speed limit in mph when used for tangent channelization.

GENERAL NOTES:

1. Final placement of signs and devices may be changed to fit field conditions as approved by the Resident.
2. Maintain same number of lanes for a shifting taper.
3. Shoulder taper allowed when a minimum of 10 feet can be open from centerline for lane.

Road Type	Distance Between Signs**		
	A	B	C
Urban 30 mph or less	100	100	100
Urban 35 mph and greater	350	350	350
Rural	500	500	500
Expressway / Urban Parkway	1000	1500	2640

**Distances are shown in feet.

SUGGESTED BUFFER ZONE LENGTHS

Speed (mph)	Length (feet)	Speed (mph)	Length (feet)
20	115	40	325
25	155	45	360
30	200	50	425
35	250	55	495

STANDARD DETAIL UPDATES

Standard Details and Standard Detail updates are available at:
<http://maine.gov/mdot/contractors/publications/standarddetail/>

<u>Detail #</u>	<u>Description</u>	<u>Revision Date</u>
501(02)	Pipe Pile Splice	3/05/2015
501(03)	H – Pile Splice	3/05/2015
502(04)	Concrete Curb	2/01/2019
504(07)	Diaphragm & Cross Frame Notes	10/13/2015
504(10)	Drip Bar Details	9/06/2017
505(01)	Shear Connectors	10/24/2016
507(13)	Steel Bridge Railing	6/03/2015
507(14)	Steel Bridge Railing	6/03/2015
507(31)	Barrier – Mounted Steel Bridge	8/06/2015
526(02)	Temporary Concrete Barrier	2/01/2015
526(02)	Temporary Concrete Barrier	2/01/2018
606(19)	Guardrail Type 3 – Single Rail Bridge Mounted	6/10/2019
606(21A)	Bridge Transition – Type “IA”	5/29/2019
609(08)	Precast Concrete Transition Curb	6/10/2019
609(9)	Concrete Slip Form Curb	5/06/2018
626(07)	Conduit Trench for Traffic Signals, Highway Signing and Lighting	5/17/2018
645(06)	H-Beam Posts Highway Signing	1/09/2018
652(06)	Construction Signs	10/24/2016
652(12)	Construction Traffic Control	10/24/2016
802(05)	Roadway Culvert End Slope Treatment	1/03/2017
801(11) – 801(26)	ADA Standard Details	6/03/2019

SUPPLEMENTAL SPECIFICATIONS
(Corrections, Additions, & Revisions to Standard Specifications - November 2014)

SECTION 101
CONTRACT INTERPRETATION

101.1 Abbreviations Revise the definition of AWWA to “**American Wood Protection Association**”.

101.2 Definitions

Page 1-5 – Remove the definition of Bridge in its entirety and replace with:

“Bridge A structure that is erected over a depression or an obstruction, such as water, a highway or a railway, and has an opening measured along the centerline of the Roadway of more than 20 feet between: The faces of abutments; spring line of arches; extreme ends of openings of box culverts, pipes or pipe arches; or the extreme ends of openings for multiple box culverts, pipes or pipe arches.”

Page 1-12 – Remove the definition of Large Culvert in its entirety and replace with:

“Large Culvert Any structure not defined as a Culvert or Bridge that provides a drainage or non-drainage opening under the Roadway or Approaches to the Roadway, with an opening that is 5 feet but less than 10 feet.”

Remove the definition of Minor Span in its entirety and replace with:

“Minor Span Same definition as Bridge, except having an opening of between 10 feet and 20 feet, inclusive.”

SECTION 103
AWARD AND CONTRACTING

Amend this Section by adding the following:

“103.1a Tie Bids - In the case where two responsive bids from responsible bidders are equal monetarily, the Department shall determine the apparent low bidder by flipping a coin. The coin shall have sides clearly marked as heads and tails. The contractor whose first letter in their official company name that comes first in the alphabet shall be heads.

If there are three bids, each bidder will flip the coin and the bidder with the odd toss will be the winner. (i.e. if the results are two heads and a tails, the bidder who had tails is the winner). For a three way tie, bidders may flip their own coin or have the Contracts Engineer flip for them.

The coin flip will occur at the next bid opening by the Contracts and Specifications Engineer or a designee. The tied bidders may attend the coin flip in person or watch on the internet as they choose.”

In 103.3.2 Notice of Determination Revise this section by removing sections A – M and replacing with the following A - K:

(A) Default(s) or termination(s) on past or current Contracts.

**(B) Failure on past or current Contracts to pay or settle all bills for labor, Materials or services;
to comply with directives of the Department, to fulfill warranty obligations, or to provide Closeout Documentation.**

(C) "Below Standard" performance as determined from the Department's Contractor's Performance Rating process.

(D) Insufficient bonding capability or Inability of the Contractor to obtain or retain performance or Payment Bonds meeting MDOT requirements, or a pattern of unsupported Claims.

(E) Failure to accept an Award of a Contract made by the Department.

(F) Failure to provide information requested by the Department in a timely manner.

(G) Debarment, suspension or a denial of prequalification or 'award of contract' by any federal, State, or local governmental procurement agency or the Contractor's Agreement to refrain from Bidding as part of the settlement with any such agencies or any of the reasons contained in Section 102.02 of the "Rules Regarding Debarment of Contractors", Maine Department of Transportation Register 17-229, Chapter 102 (October 2, 1985).

(H) Failure to demonstrate ability to do work to the satisfaction and at the sole discretion of the Department.

(I) Number of personnel working directly for the Contractor with applicable knowledge and experience is significantly below industry standards.

(J) Safety Record, Environmental Record, Civil Rights or Equal Opportunity Record significantly below industry standards.

(K) Serious misconduct that the Department reasonably determines will substantially and adversely affect the cost, quality or timeliness of Work, or the safety of Workers or the public, any deceptive, evasive or fraudulent statements or omissions contained in the Application, made or omitted at any interview or hearing, or otherwise made to or omitted from the Department; or any other substantial deficiencies in experience or conduct that are clearly below industry standards and that clearly demonstrate in the sole discretion of the Department, that the Contractor is "Not Qualified".

SECTION 104 **GENERAL RIGHTS AND RESPONSIBILITIES**

This Section shall be amended by adding the following two sub-sections:

104.3.8.1 Electronic Payroll Submission On federally funded projects the prime contractor, all subcontractors, and lower-tier subcontractors will submit their certified payrolls electronically utilizing the Elations system. There is no charge to the contracting community for the use of this service. The submission of paper payrolls will not be allowed or accepted. Additional information can be found at <http://www.maine.gov/mdot/contractors/> under the “Bidder Info” go to “Electronic Payroll System.”

104.3.8.2 Payment Tracking On federally funded projects the prime contractor and all subcontractors and lower-tier subcontractors will track and confirm the delivery and receipt of all payments through the Elation System

104.4.10 Coordination of Road Closure / Bridge Closure / Bridge Width Restrictions

Revise the last sentence by adding a period after ‘Resident’; remove the “and” after Resident; and adding “**not covered by Pay Items**” between ‘costs’ and ‘will’. So that the last paragraph reads “**All Newspaper notices, radio announcements and any notifications will be subject to the approval of the Resident. All costs not covered by Pay Items will be considered incidental to the Contract.**”.

104.5.5 Prompt Payment of Subcontractors Add the following paragraph to this subsection:

C. Payment Tracking Federal Projects On federally funded projects, the prime contractor, subcontractors and lower-tier subcontractors will track and confirm the delivery and receipt of all payments through the Elation System. They will be responsible for entering all payments to all sub and lower tier contractors. MaineDOT will run a query monthly to ensure that contractors are complying and generate an e-mail to contractors who have not responded to confirm receipt of MaineDOT payment or contractor payment to lower tier subcontractors.

SECTION 105 **GENERAL SCOPE OF WORK**

105.2.5 Compliance with Health and Safety Laws Remove the second paragraph of this subsection in its entirety and replace with:

“For related provisions, see Sections 105.2.3 – Project Specific Emergency Planning, 105.3 – Traffic Control and Management and 105.4 – Maintenance of work.”

105.4.5 Special Detours Remove this subsection in its entirety and replace with:

“105.4.5 Maintenance of Existing Structures When a new Bridge or Minor Span is being installed on a new alignment and the existing structure is to remain in service, the Department will maintain the existing structure and the portions of the roadway required for maintaining traffic until such time that the new structure is opened to traffic and the existing structure is taken out of service. A similar situation exists when a new Bridge or Minor Span is being installed on the same alignment as the existing structure, requiring a temporary detour to be installed by the Contractor per Section 510, Special Detours, prior to removal of the existing structure. In this case, the Department will maintain the existing structure and the portions of the existing roadway required for maintaining traffic until such time that either the temporary detour is opened to traffic or the Contractor begins any work on the existing structure, including, but not limited to, repairs, modifications, moving, demolition or removal. In either case, once the new structure or temporary detour is opened to traffic, or the Contractor begins any work on the existing structure, the Contractor shall be solely responsible for all maintenance of the existing structure and the portions of the existing approaches that lie outside the new roadway or the temporary detour, respectively. This specification is not intended to supersede Standard Specification Section 104.3.11, Responsibility for Property of Others.”

105.6.2.4 Department Verification Add the following to the end of the first sentence:
“or other approved method, such as reference staking, to allow the Department to independently verify the accuracy of the work, as approved by the Department.”

SECTION 106 **QUALITY**

106.3.4 Storage Revise this Section by adding the following sentence after the first sentence:
“Materials shall not be stored under or in close proximity to Highway Structures unless the Contractor receives written permission from the Resident.”

106.4.1 General - In the first sentence, remove “When required by Special Provision,” and replace with **“When required elsewhere in the Contract,”**

Revise Subsection C by replacing the last sentence with the following:

Approval of both standard and project specific QCPs shall be as outlined in paragraph B above, with the exception that the initial 14 day review period for standard plans will begin on March 1, and that the supplemental project specific QCP for the project shall be submitted a minimum of 14 days prior to any related work being performed with an initial review period of 7 days.

Revise Subsection 106.4.6 by removing it in its entirety and replace it with:

“106.4.6 QCP Non-Compliance The Contractor shall comply with the approved QCP and shall take all other steps necessary to assure a high quality project.

Failure by the Contractor to comply with the approved Quality Control Plan will result in a letter describing the violation, a mandatory work suspension, and a reduction in payment as shown in Table 106.4A below. The Contractor shall submit a letter to the Department that details the corrective action made to address the violation in their Quality Control Plan. Work may resume when the Department it is satisfied the corrective action will result in adherence to the Quality Control Plan.

Table 106.4 A - Quality Control Pay Reduction

Quality Control Plan Value*		Pay Reduction		
From More Than	To and Including	1st	2nd	3rd & Subsequent
\$0	\$500,000	\$1,000	\$2,000	\$4,000
\$500,000	\$1,000,000	\$2,000	\$4,000	\$8,000
\$1,000,000	\$3,000,000	\$5,000	\$10,000	\$20,000
\$3,000,000	and more	\$10,000	\$20,000	\$40,000

* The Quality Control Plan Value is the total bid value of all items covered by a Quality Control Plan, as detailed in the applicable specification or Special Provision.

During all periods of the Contractor’s failure to follow the approved QCP, no positive pay incentives will be calculated or paid if the Department accepts the material.

Pay reductions for failure to comply with the approved QCP are additive, and the Department will deduct any pay reductions due from amounts otherwise due the Contractor. These pay reductions are intended to encourage the Contractor to comply with its approved QCP, and are not related to the quality of the material provided.”

Amend this Section by adding the following Subsection:

“106.7.3 Early Termination of Lots In the event a lot in progress is terminated prematurely before the Department is able to take the number of acceptance samples required by the test method specified in the contract, the following will apply as applicable unless otherwise detailed in the specifications for the item:

- A. If three or more samples have been taken, then payfactors will be generated using the available samples results for the lot.
- B. If the termination was requested by the Contractor and approved by the Department prior to three samples being taken, then each property’s payfactor will be set to 0.80.
- C. If the termination was initiated by the Department prior to three samples being taken, then each property’s payfactor will be set to 1.00 for each property.”

SECTION 107
TIME

107.7.2 SCHEDULE OF LIQUIDATED DAMAGES

Revise this section by removing the numbers in the chart and replace with the following:

Original Contract Amount		Per Diem Amount of Liquidated Damages
From More Than	To and Including	Calendar Day
\$ 0	to \$ 100,000.00	\$250.00
\$ 100,000.00	to \$ 250,000.00	\$500.00
\$ 250,000.00	to \$ 500,000.00	\$650.00
\$ 500,000.00	to \$1,000,000.00	\$800.00
\$1,000,000.00	to \$2,000,000.00	\$1,000.00
\$2,000,000.00	to \$4,000,000.00	\$1,200.00
\$4,000,000.00	and More	\$2,100.00

SECTION 108
PAYMENT

108.3 Retainage - Remove the paragraph beginning with “ The Contractor may withdraw...” in its entirety.

108.4.1 Price Adjustment for Hot Mix Asphalt:
Remove this section in its entirety and replace with the following

For all contracts with hot mix asphalt in excess of 500 tons total, a price adjustment for performance graded binder will be made for the following pay items:

- Item 403.102 Hot Mix Asphalt – Special Areas**
- Item 403.206 Hot Mix Asphalt - 25 mm**
- Item 403.207 Hot Mix Asphalt - 19 mm**
- Item 403.2071 Hot Mix Asphalt - 19 mm (Polymer Modified)**
- Item 403.2072 Hot Mix Asphalt - 19 mm (Asphalt Rich Base)**
- Item 403.208 Hot Mix Asphalt - 12.5 mm**
- Item 403.2081 Hot Mix Asphalt - 12.5 mm (Polymer Modified)**
- Item 403.209 Hot Mix Asphalt - 9.5 mm (sidewalks, drives, & incidentals)**
- Item 403.210 Hot Mix Asphalt - 9.5 mm**
- Item 403.2101 Hot Mix Asphalt - 9.5 mm (Polymer Modified)**
- Item 403.2102 Hot Mix Asphalt - 9.5 mm (Asphalt Rich Base)**

Item 403.2104	Hot Mix Asphalt - 9.5 mm (Thin Lift Surface Treatment)
Item 403.21041	Hot Mix Asphalt - 9.5 mm (Polymer Modified Thin Lift Surface Treatment)
Item 403.211	Hot Mix Asphalt – Shim
Item 403.2111	Hot Mix Asphalt – Shim (Polymer Modified)
Item 403.212	Hot Mix Asphalt - 4.75 mm (Shim)
Item 403.213	Hot Mix Asphalt - 12.5 mm (base and intermediate course)
Item 403.2131	Hot Mix Asphalt - 12.5 mm (base and intermediate course Polymer Modified)
Item 403.2132	Hot Mix Asphalt - 12.5 mm (Asphalt Rich Base and intermediate course)
Item 403.214	Hot Mix Asphalt - 4.75 mm (Surface)
Item 403.235	Hot Mix Asphalt (High Performance Rubberized HMA)
Item 403.301	Hot Mix Asphalt (Asphalt Rubber Gap-Graded)
Item 404.70	Colored Hot Mix Asphalt – 9.5mm (Surface)
Item 404.72	Colored Hot Mix Asphalt – 9.5mm (Islands, sidewalks, & incidentals)
Item 461.13	Light Capital Pavement
Item 461.210	9.5 mm HMA - Paver Placed Surface
Item 462.30	Ultra-Thin Bonded Wearing Course
Item 462.301	Polymer Modified Ultra-Thin Bonded Wearing Course

Price adjustments will be based on the variance in costs for the performance graded binder component of hot mix asphalt. They will be determined as follows:

The quantity of hot mix asphalt for each pay item will be multiplied by the performance graded binder percentages given in the table below times the difference in price between the base price and the period price of asphalt cement. Adjustments will be made upward or downward, as prices increase or decrease.

Item 403.102	-6.2%
Item 403.206	-4.8%
Item 403.207	-5.2%
Item 403.2071	-5.2%
Item 403.2072	-5.8%
Item 403.208	-5.6%
Item 403.2081	-5.6%
Item 403.209	-6.2%
Item 403.210	-6.2%
Item 403.2101	-6.2%
Item 403.2102	-6.8%
Item 403.2104	-6.2%
Item 403.21041	-6.2%
Item 403.211	-6.2%
Item 403.2111	-6.2%
Item 403.212	-6.8%
Item 403.213	-5.6%
Item 403.2131	-5.6%

Item 403.2132–6.2%
Item 403.214–6.8%
Item 403.235–5.5%
Item 403.301–6.2%
Item 404.70–6.2%
Item 404.72–6.2%
Item 461.13–6.7%
Item 461.210 – 6.4%
Item 462.30–0.0021 tons/SY
Item 462.301–0.0021 tons/SY

Hot Mix Asphalt: The quantity of hot mix asphalt will be determined from the quantity shown on the progress estimate for each pay period.

Base Price: The base price of performance graded binder to be used is the price per standard ton current with the bid opening date. This price is determined by using the average New England Selling Price (Excluding the Connecticut market area), as listed in the Asphalt Weekly Monitor.

Period Price: The period price of performance graded binder will be determined by the Department by using the average New England Selling Price (Excluding the Connecticut market area), listed in the Asphalt Weekly Monitor current with the paving date. The maximum Period Price for paving after the adjusted Contract Completion Date will be the Period Price on the adjusted Contract Completion Date.

SECTION 109 **CHANGES**

109.5.1 Definitions - Types of Delays

Delete Paragraph 'A' in its entirety and replace with:

"A. Excusable Delay Except as expressly provided otherwise by this Contract, an "Excusable Delay" is a Delay to the Critical Path that is directly and solely caused by (1) a weather related Event of such an unusually severe nature that a Federal Emergency Disaster is declared. The Contractor will only be entitled to an adjustment of time if the Project falls within the geographic boundaries prescribed under the disaster declaration. or (2) a flooding event at the effected location of the Project that results in a Q25 headwater elevation, or greater, but less than a Q50 headwater elevation. Theoretical headwater elevations will be determined by the Department; actual headwater elevations will be determined by the Contractor and verified by the Department or (3) An Uncontrollable Event.”

SECTION 110
INDEMNIFICATION, BONDING AND INSURANCE

110.3.9 Administrative & General Provisions

B. Defense of Claims Amend this section by adding the following sentence to the end:
“The Contractor’s insurer shall name the Department of Transportation as a released party (Releasee”) on any release or settlement agreement for settled claims.”

APPENDIX A TO DIVISION 100

Remove Section D in its entirety as this is now covered in Section 105.10 EQUAL OPPORTUNITY AND CIVIL RIGHTS.

SECTION 203
EXCAVATION AND EMBANKMENT

203.02 Materials

At the bottom of page 2-12, add as the first item in the list:

Crushed Stone, ¾ inch 703.13

203.042 Rock Excavation and Blasting

On page 2-16, add the word “**No**” to the third sentence in Section 5 Submittals, Subsection V, 1 so that it reads:

“No blasting products will be allowed on the job site if the date codes are missing.”

203.09 Preparation of Embankment Area Revise the first sentence of the second paragraph so that it reads:

“When fill material is placed against existing slopes or previously placed fill, the interface shall be continuously benched by excavating steps of sufficient width to permit operations of placing and compacting the additional material.”

SECTION 304
AGGREGATE BASE AND SUBBASE COURSE

Remove Section 304.02 Aggregate entirely and replace with the following:

304.02 Aggregate Aggregates shall conform to the requirements specified in the following subsections of Division 700 - Materials:

Aggregate Base	Type A & B	703.06 a
-----------------------	-----------------------	-----------------

Aggregate Base	Type C	703.06 b
Aggregate Subbase	Type D & E	703.06 c

Aggregate for base or subbase courses shall be material meeting the aggregate type requirements specified in the following table:

Material	Aggregate Type (Subsection 703.06)
Base Course, Crushed	¹ A, B or C
Subbase Course, Gravel	² D
¹ Will be designated on the plans ² Subbase Course, Gravel-Type E may be used below the top 9" of the subbase layer at the Contractor's option	

For the various types of base and subbase, all shall conform to the gradation requirements of the contract at the time it is deposited on the roadbed. The Department will obtain samples from the roadbed for Acceptance prior to compaction. Oversized stones shall be removed from the aggregate before depositing on the roadway. Oversized stones for the various types are as follows:

- Type A will not pass a 2 inch square mesh sieve
- Type B and Type C will not pass a 4 inch square mesh sieve
- Type D and E will not pass a 6 inch square mesh sieve."

The top 3" of Aggregate Base Course-Type C shall consist of Recycled Asphalt Pavement (RAP) or Untreated Aggregate Surface Course-Type B.

304.04 Shaping, Compacting, and Stabilizing Revise the first paragraph in this section by removing "according to AASHTO T 224" and "(An Adjustment Chart/Spreadsheet for this correction is available upon request)" so that it reads:

"Compaction of each layer of base and subbase shall continue until a density of not less than 95% of the maximum density has been achieved for the full width and depth of the layer. The maximum density shall be determined in accordance with AASHTO T180, Method C or D, correcting for oversize particles except mixtures may have 40 percent or less retained on the 3/4 inch sieve. Field density tests will be performed by the Department in accordance with AASHTO T 310."

304.04 Shaping, Compacting, and Stabilizing Replace the tenth paragraph in this section in its entirety with:

"If the Contractor wishes to route public traffic over the completed Aggregate Base-Type A and B or Aggregate Subbase Course for a period of time greater than 48 hours, the Aggregate Base and Aggregate Subbase Course shall be constructed with a minimum 2"

surcharge above the design grade. Surcharge shall be constructed with material meeting the requirements of Section 703.06(b), Subbase Aggregate-Type D. Whenever the surcharge is used, it shall be placed on all the Aggregate Base and Aggregate Subbase Course subjected to public traffic. When the surcharge is removed, it may be placed in driveways, sidewalks, approach roads, or the outer portions of the shoulders. Removal of the surcharge shall be followed immediately in succession by the fine grading of the aggregate base or subbase and construction of the HMA base layer. As per subsection 203.041 Salvage of Existing Hot Mix Asphalt Pavement, Recycled Asphalt Pavement (RAP) may be used as the top 3" of aggregate. If RAP is utilized as the top 3", a surcharge is not required."

304.04 Shaping, Compacting, and Stabilizing Replace the eleventh paragraph in this section in its entirety with:

"The furnishing, placing, maintaining, and removal of the surcharge will not be paid for directly, but will be considered incidental to the Aggregate Base or Aggregate Subbase course pay item."

Section 304.07 Basis of Payment add the following:

"RAP or Untreated Aggregate Surface Course-Type B used to cap Aggregate Base Course-Type C will be paid for as Item 304.16-Aggregate Base Course -Type C."

SECTION 307 FULL DEPTH RECYCLED PAVEMENT

Remove this Section in its entirety and replace with:

SECTION 307 FULL DEPTH RECYCLING (UNTREATED OR TREATED WITH EMULSIFIED ASPHALT STABILIZER)

307.01 Description This work shall consist of pulverizing a portion of the existing roadway structure into a homogenous mass, adding an emulsified asphalt stabilizer (if required) to the depth of the pulverized material specified in the contract, placing and compacting this material to the lines, grades, and dimensions shown on the plans or established by the Resident.

MATERIALS

307.02 Pulverized Material Pulverized material shall consist of the existing asphalt pavement layers and one inch or more as specified of the underlying gravel, pulverized and blended into a homogenous mass. Pulverized material will be processed to 100% passing a 2 inch square mesh sieve.

307.021 New Aggregate and Additional Recycled Material New aggregate, if required by the contract, shall meet the requirements of Subsection 703.10 - Aggregate for Untreated Surface Course and Leveling Course, Type A. Aggregate Subbase Course Gravel Type D processed to 100 percent passing a 2 inch square mesh sieve and meeting the requirements of 703.06 – Aggregate for Base and Subbase may be used in areas requiring depths greater than 2 inches. New aggregate, will be measured and paid for under the appropriate item.

Recycled material, if required, shall consist of salvaged asphalt material from the project or from off-site stockpiles that has been processed before use to 100 percent passing a 2 inch square mesh sieve. Recycled material shall be conditionally accepted at the source by the Resident. It shall be free of winter sand, granular fill, construction debris, or other materials not generally considered asphalt pavement.

Recycled material generated and salvaged from the project shall be used within the roadway limits to the extent it is available as described in 307.09. No additional payment will be made for material salvaged from the project.

Recycled material supplied from off-site stockpiles shall be paid for as described in the contract, or by contract modification.

307.022 Emulsified Asphalt Stabilizer. If required, the emulsified asphalt stabilizer shall be grade MS-2, MS-4, SS-1, or CSS-1 meeting the requirements of Subsection 702.04 Emulsified Asphalt.

307.023 Water Water shall be clean and free from deleterious concentrations of acids, alkalis, salts or other organic or chemical substances.

307.024 Portland Cement If required, Portland Cement shall be Type I or II meeting the requirements of AASHTO M85.

307.025 Hydrated Lime If required, Hydrated Lime shall meet the requirements of AASHTO M216.

EQUIPMENT

307.03 Pulverizer The pulverizer shall be a self-propelled machine, specifically manufactured for full-depth recycling work and capable of reducing the required existing materials to a size that will pass a 2 inch square mesh sieve. The machine shall be equipped with standard automatic depth controls and must maintain a consistent cutting depth and width. The machine also shall be equipped with a gauge to show depth of material being processed.

307.04 Liquid Mixer Unit or Distributor. If treatment of the recycled layer with emulsified asphalt is required by the contract, a liquid mixing unit or distributor shall be used to introduce the emulsified asphalt stabilizer into the pulverized material. The mixing unit shall contain a liquid distribution and mixing system which has been specifically manufactured for full-depth recycling work, capable of mixing the pulverized material with an evenly metered

distribution of emulsified asphalt into a homogeneous mixture, to the depth and width required.

The mixing unit shall be designed, equipped, maintained, and operated so that emulsified asphalt stabilizer at constant temperature may be applied uniformly on variable widths of pulverized material up to 6 feet at readily determined and controlled rates from 0.01 to 1.06 gal/yd² with uniform pressure and with an allowable variation from any specified rate not to exceed 0.01 gal/ yd². Mixing units shall include a tachometer, pressure gages, and accurate volume measuring devices or a calibrated tank and a thermometer for measuring temperatures of tank contents.

307.041 Cement or Lime Spreader If required by the contract, spreading of the Portland Cement or Hydrated Lime shall be done with a spreader truck designed to spread dry particulate (such as Portland Cement or Lime) or other approved means to insure a uniform distribution across the roadway and minimize fugitive dust. Pneumatic application, including through a slotted pipe, will not be permitted. Other systems that have been developed include fog systems, vacuum systems, etc. Slurry applications may also be accepted. The Department reserves the right to accept or reject the method of spreading cement. The Contractor shall provide a method for verifying that the correct amount of cement is being applied.

307.05 Placement Equipment Placement of the Full Depth recycled material to the required slope and grade shall be done with an approved highway grader or by another method approved by the Resident.

307.06 Rollers The full depth recycled material shall be rolled with a vibratory pad foot roller, a vibratory steel drum soil compactor and a pneumatic tire roller. The pad foot roller drum shall have a minimum of 112 tamping feet 3 inches in height, a minimum contact area per foot of 17 inch², and a minimum width of 84 inches. The vibratory steel drum roller shall have a minimum 84 inch width single drum. The pneumatic tire roller shall meet the requirements of Section 401.10 and the minimum allowable tire pressure shall be 85 psi.

MIX DESIGN

If treatment of the recycled layer with emulsified asphalt is required by the contract, the Department will supply a mix design for the emulsified asphalt stabilized material based on test results from pavement and soil analysis taken to the design depth. The Department will provide the following information prior to construction:

1. Percent of emulsified asphalt to be used.
2. Quantity of lime or cement to be added.
3. Optimum moisture content for proper compaction.
4. Additional aggregate (if required).

After a test strip has been completed or as the work progresses, it may be necessary for the Resident to make necessary adjustments to the mix design. Changes to compensation will be in accordance with the Mix Design Special Provision.

CONSTRUCTION REQUIREMENTS

307.06 Pulverizing The entire depth of existing pavement shall be pulverized together with 1 inch or more of the underlying gravel into a homogenous mass. All pulverizing shall be done with equipment that will provide a homogenous mass of pulverized material, processed in-place, which will pass a 2 inch square mesh sieve.

307.07 Weather Limitations Full depth recycled work shall be performed when;

- A. Recycling operations will be allowed between May 15th and September 15th inclusive in Zone 1 - Areas north of US Route 2 from Gilead to Bangor and north of Route 9 from Bangor to Calais. Recycling will be allowed between May 1st and September 30th inclusive in Zone 2 - Areas south of Zone 1 including the US Route 2 and Route 9 boundaries.
- B. The atmospheric temperature, as determined by an approved thermometer placed in the shade at the recycling location, is 50°F and rising.
- C. When there is no standing water on the surface.
- D. During generally dry conditions, or when weather conditions are such that proper pulverizing, mixing, grading, finishing and curing can be obtained using proper procedures, and when compaction can be accomplished as determined by the Resident.
- E. When the surface is not frozen and when overnight temperatures are expected to be above 32°F.
- F. Wind conditions are such that the spreading of lime or cement on the roadway ahead of the recycling machine will not adversely affect the operation.

307.08 Surface Tolerance The complete surface of the Full Depth Recycled course shall be shaped and maintained to a tolerance, above or below the required cross sectional shape, of $\frac{3}{8}$ inch.

307.09 Full Depth Recycling Procedure New aggregate or recycled material meeting the requirements of Section 307.021 - New Aggregate and Additional Recycled Material, shall be added as necessary to restore cross-slope and/or grade before pulverizing. Locations will be shown on the plans or described in the construction notes. The Resident may add other locations while construction of the project is in progress. The Contractor will use recycled material to the extent it is available, in lieu of new aggregate. The material shall then be pulverized, processed, and blended into a homogeneous mass passing a 2 inch square mesh sieve. Material found not pulverized down to a 2 inch size will be required to be reprocessed by the recycler with successive passes until approved by the Resident.

Should the Contractor be required to add new aggregate or recycled material to restore cross-slope and/or grade after the initial pulverizing process, those areas will require re-processing to blend into a homogenous mass passing a 2 in square mesh sieve.

Sufficient water shall be added during the recycling process to maintain optimum moisture for compaction.

The resultant material from the initial pulverizing processes shall be graded and compacted to the cross-slope and profile shown on the plans or as directed by the Resident. The Contractor will also be responsible for re-establishing the existing profile grade. The completed surface of the full depth recycled course shall be shaped and maintained to a tolerance, above or below the required cross sectional shape, of $\frac{3}{8}$ inch. Areas not meeting this tolerance will be repaired as described in Section 307.091. The initial pulverizing process density requirements will be the same as Section 307.101 unless otherwise directed by the Resident.

Additives, if required, shall be introduced following completion of the initial pulverizing and blending process. Emulsified asphalt stabilizer shall be incorporated into the top of the processed material as specified in section 307.04 to the depth specified in the contract by use of the liquid mixer unit or a distributor, at the rate specified in the mix design. The emulsified asphalt shall then be uniformly blended into a homogeneous mass until an apparent uniform distribution has occurred. The rate of application may be adjusted as necessary by the Resident. Cement or lime shall be introduced as described in section 307.041. The resultant material shall be graded and compacted to the cross-slope and profile shown on the plans or as directed by the Resident. The Contractor will also be responsible for re-establishing the existing profile grade.

After final compaction, the roadway surface shall be treated with a light application of water, and rolled with pneumatic-tired rollers to create a close-knit texture. The finished layer shall be free from:

- A. Surface laminations.
- B. Segregation of fine and coarse aggregate.
- C. Corrugations, centerline differential, potholes, or any other defects that may adversely affect the performance of the layer, or any layers to be placed upon it.

The Contractor shall protect and maintain the recycled layer until a lift of pavement is applied. Any damage or defects in the layer shall be repaired immediately. An even and uniform surface shall be maintained. The recycled surface shall be swept prior to hot mix asphalt overlay placement.

307.091 Repairs Repairs and maintenance of the recycled layers, resulting from damage caused by traffic, weather or environmental conditions, or resulting from damage caused by the Contractor's operations or equipment, shall be completed at no additional cost to the Department.

For recycled layers stabilized with emulsified asphalt, low areas will be repaired using a hot mix asphalt shim. Areas up to 1 inch high can be repaired by milling or shimming with hot mix asphalt. Areas greater than 1 inch high will be repaired using a hot mix asphalt shim. All repair work will be done with the Resident's approval at the Contractor's expense.

TESTING REQUIREMENTS

307.10 Quality Control The Contractor shall operate in accordance with the approved Quality Control Plan (QCP) to assure a product meeting the contract requirements. The QCP shall

meet the requirements of Section 106.4 - Quality Control and this Section. The Contractor shall not begin recycling operations until the Department approves the QCP in writing. Prior to performing any recycling process, the Department and the Contractor shall hold a Pre-recycle conference to discuss the recycling schedule, type and amount of equipment to be used, sequence of operations, and traffic control. A copy of the QC random numbers to be used on the project shall be provided to the Resident. All field supervisors including the responsible onsite recycling process supervisor shall attend this meeting.

The QCP shall address any items that affect the quality of the Recycling Process including, but not limited to, the following:

- A. Sources for all materials, including New Aggregate and Additional Recycled Material.
- B. Make and type of rollers including weight, weight per inch of steel wheels, and average contact pressure for pneumatic tired rollers.
- C. Testing Plan.
- D. Recycling operations including recycling speed, methods to ensure that segregation is minimized, grading and compacting operations.
- E. Methods for protecting the finished product from damage and procedures for any necessary corrective action.
- F. Method of grade checks.
- G. Examples of Quality Control forms.
- H. Name, responsibilities, and qualifications of the Responsible onsite Recycling Supervisor experienced and knowledgeable with the process.
- I. A note that all testing will be done in accordance with AASHTO and MDOT/ACM procedures.

The Project Superintendent shall be named in the QCP, and the responsibilities for successful implementation of the QCP shall be outlined.

The Contractor shall sample, test, and evaluate the full depth reclamation process in accordance with the following minimum frequencies:

MINIMUM QUALITY CONTROL FREQUENCIES

Test or Action	Frequency	Test Method
Density	1 per 1000 feet / lane	AASHTO T 310
Air Temperature	4 per day at even intervals	
Surface Temperature	At the beginning and end of each days operation	
Yield of all materials (Daily yield, yield since last test, and total project yield.)	1 per 1000 ft/lane	

The Department may view any QC test and request a QC test at any time. The Contractor shall submit all QC test reports and summaries in writing, signed by the appropriate technician, to the Department's onsite representative by 1:00 P.M. on the next working day, except when otherwise

noted in the QCP due to local restrictions. The Contractor shall make all test results, including randomly sampled densities, available to the Department onsite.

The Contractor shall cease recycling operations whenever one of the following occurs:

- A. The Contractor fails to follow the approved QCP.
- B. The Contractor fails to achieve 98 percent density after corrective action has been taken.
- C. The finished product is visually defective, as determined by the Resident.
- D. The computed yield differs from the mix design by 10 percent or more.

Recycling operations shall not resume until the Department approves the corrective action to be taken.

307.101 Test Strip The contractor shall assemble all items of equipment for the recycling operation on the first day of the recycling work. The Contractor shall construct a test strip for the project at a location approved by the Resident. The Responsible onsite Recycling Supervisor will work with Department personnel to determine the suitability of the mixed material, moisture control within the mixed material, and compaction and surface finish. The test strip section is required to:

- A. Demonstrate that the equipment and processes can produce recycled layers to meet the requirements specified in these special provisions.
- B. Determine the effect on the gradation of the recycled material by varying the forward speed of the recycling machine and the rotation rate of the milling drum.

- C. Determine the optimum moisture necessary to achieve proper compaction of the recycled layer.
- D. Determine the sequence and manner of rolling necessary to obtain the compaction requirements and establish a target density. The Contractor and the Department will both conduct testing with their respective gauges at this time.

The test strip shall be at least 300 feet in length of a full lane-width (or a half-road width). Full recycling production will not start until a passing test strip has been accomplished. If a test strip fails to meet the requirements of this specification, the Contractor will be required to repair or replace the test strip to the satisfaction of the Resident. Any repairs, replacement, or duplication of the test strip will be at the Contractor's expense.

After the test strip has been pulverized, and the roadway brought to proper shape, the Contractor shall add water until it is determined that optimum moisture has been obtained. The test strip shall then be rolled using the specified compaction equipment as directed until the density readings show an increase in dry density of less than 1 pcf for the final four roller passes of each roller. The Contractor and Department will each determine a target density using their respective gauges by performing several additional density tests and averaging them. The average of these tests will be used as the target density of the recycled material for QC and Acceptance purposes.

Following completion of the test strip, compaction of the material shall continue until a density of not less than 98 percent of the test strip target density has been achieved for the full width and depth of the layer. During the construction and compaction of the Full Depth Recycled base, should three consecutive Acceptance test results for density fail to meet a minimum of 95 percent of the target density, or exceed 102 percent of target density, a new test strip shall be constructed.

ACCEPTANCE TEST FREQUENCY

Property	Frequency	Test Method
In-place Density	1 per 2000 ft / lane	AASHTO T 310

307.102 Curing. No new pavement shall be placed on the full depth recycled pavement until curing has reduced the moisture content to 1 percent or less by total weight of the mixture, or a curing period of 4 days has elapsed, whichever comes first.

307.11 Method of Measurement Full Depth Recycled Pavement (Untreated or Treated with Emulsified Asphalt Stabilizer) will be measured by the square yard.

307.12 Basis of Payment The accepted quantity of Full Depth Recycled Asphalt Pavement (Untreated or Treated with Emulsified Asphalt Stabilizer) will be paid for at the contract unit price per square yard, complete in-place which price will be full compensation for furnishing all equipment, materials and labor for pulverizing, blending, placing, grading, compacting, and for all incidentals necessary to complete the work.

The addition of materials to restore profile grade and/or cross-slope in areas shown on the plans or described in the construction notes will be paid separately under designated pay items within the contract. No additional payment will be made for materials salvaged from the project.

Payments will be made under:

<u>Pay Item</u>	<u>Pay Unit</u>
307.331 Full Depth Recycled Pavement (Untreated)	Square Yard
307.332 Full Depth Recycled Pavement (with Emulsified Asphalt Stabilizer) 5 in. depth	Square Yard
307.333 Full Depth Recycled Pavement (with Emulsified Asphalt Stabilizer) 6 in. depth	Square Yard

SECTION 411 **UNTREATED AGGREGATE SURFACE COURSE**

411.02 – Aggregate Add the following to the end of the first sentence: “- Type A”

SECTION 501 **FOUNDATION PILES**

501.047 Splicing Piles Remove subsection 501.047 d 3, which states “Written welding procedures do not need to be submitted”, in its entirety.

501.05 – Method of Measurement

- b. Piles Furnished – After the second sentence, add the sentence “**Measurement will not include any pile tips**”.
- c. Piles in Place – Add the sentence to the end of the second paragraph, “**Measurement will include the pile tips**”.
- d. Pile Tips – Add the words “**on the Pile**” to the end of the sentence.

SECTION 502
STRUCTURAL CONCRETE

502.05 Composition and Proportioning

Replace Table 1 with

TABLE 1

Concrete CLASS	Minimum Compressive Strength (PSI)	Permeability as indicated by Surface Resistivity (KOhm-cm)	Entrained Air (%)		Notes
			LSL	USL	
S	3,000	LSL N/A	LSL N/A	USL N/A	4,5
A	4,000	14	6.0	9.0	1,4,5
P	-----	-----	5.5	7.5	1,2,3,4
LP	5,000	17	6.0	9.0	1,4,5
Fill	3,000	N/A	6.0	9.0	4,5

In the list of information submitted by the contractor for a mix design:

Item J Replace “Target Coulomb Value.” with “Target KOhm-cm Value.”

Note #1 - Remove, “...Standard Specification Section 711.05, Protective Coating for Concrete Surfaces, and per the manufacturer’s recommendations, at no additional cost to the Department.” and replace with, “...Standard Specification Section 515, Protective Coating for Concrete Surfaces, at no additional cost to the Department.”

502.1703 Acceptance Methods A and B

In the paragraph that starts with “The Department will take Acceptance...” Remove the word chloride from chloride permeability in the last sentence.

Replace the paragraph starting with “Rapid Chloride Permeability specimens...” With the following:

“Surface Resistivity specimens will be tested by the Department in accordance with AASHTO TP-95 at an age ≥ 56 days. Four 4 inch x 8 inch cylinders will be cast per subplot placed. The average of three concrete specimens per subplot will constitute a test result and this average will be used to determine the permeability for pay adjustment computations.”

502.1706 Acceptance Method C

Remove in its entirety and Replace with:

502.1706 Acceptance Method C The Department will determine the acceptability of the concrete through Acceptance testing. Acceptance tests will include compressive strength, air content and permeability. Method C concrete not meeting the requirements listed in Table 1 shall be removed and replaced at no cost to the Department. At the Department’s sole discretion, material not meeting requirements may be left in place and paid for at a reduced price as described in Section 502.195.

502.1707 Resolution of Disputed Acceptance Test Results

Section B

Remove “Rapid Chloride” from the section heading.

In paragraph 4 replace T-277 with TP-95

502.192 Pay Adjustment for Chloride Permeability

Remove “Chloride” from the heading and from the first sentence.

Replace the sentence that starts with “values greater than...” and replace with “values less than 10 KOhms-cm for Class A concrete or 11 KOhms-cm for Class LP concrete shall be subject to rejection and replacement, at no additional cost to the Department.”

502.194 Pay Adjustments for Compressive Strength, Chloride Permeability and Air Content, Methods A and B

Remove the word “Chloride” from the section heading and from the equation for CPF.

502.195 Pay Adjustment Method C

In Table 6: Method C Pay Reductions (page 5-53)

Under “Entrained Air” for “Class Fill”, in the first line, change from “< 4.0 (Removal)” to “< **4.5 (Removal)**”

In Table 6: Method C PAY REDUCTIONS, revise the Chloride Permeability section by removing it in its entirety and replacing it with:

Surface Resistivity {Permeability in Kohm-cms and Pay Reduction per CY}			
15-16 (\$50)	13 (\$25)	N/A	N/A
13-14 (\$75)	12(\$50)	N/A	N/A
12 (\$100)	11 (\$75)	N/A	N/A
11 (\$125)	10 (\$100)	N/A	N/A
< 11 (Removal)	< 10 (Removal)	N/A	N/A

SECTION 503 **REINFORCING STEEL**

503.06 Placing and Fastening Revise this Subsection by removing, in its entirety, the paragraph which begins, “Stainless steel reinforcement shall not be tied to any other type of reinforcement.....”

SECTION 504 **STRUCTURAL STEEL**

504.06 Inspection Revise this section by removing the last sentence in the first paragraph which reads “Make the results of all measurements and testing available to the QAI.” And replace with **“Provide a copy of all measurements and testing to the QAI.”**

504.08 Rejections Amend this section by adding the following sentences to the end of the 1st paragraph: **“Structural Defects: Repair structural defects only with the approval of the Fabrication Engineer. Submit a nonconformance report (NCR) to the Fabrication Engineer with a proposed repair procedure. Do not perform structural repairs without an NCR that has been reviewed by the Fabrication Engineer. Give the QAI adequate notice prior to beginning structural repairs.”**

504.13 Unpainted Steel Revise this section by removing the third sentence which reads “Clean steel that is abrasive-blast cleaned prior to fabrication in accordance with SSPC-SP 1 Solvent Cleaning after fabrication is complete.” And replace it with: **“Clean steel that is abrasive cleaned prior to fabrication in accordance with SSPC-SP 6 shall be cleaned in accordance with SSPC-SP 1 Solvent Cleaning after fabrication is complete.”**

504.26 Welding Remove the second paragraph beginning with “The range of heat....” in its entirety.

504.29 Welding ASTM A 709 HPS 70W Steel. Remove the third paragraph beginning with “Make Weld runoff tabs...” in its entirety.

504.55 Field Welding Revise the first paragraph by replacing the word “Resident” with **“Fabrication Engineer”**.

504.60 Holes for Base Plates Revise this section by removing the second sentence and replacing it with **“The roughness shall not exceed condition of AWS C4.1-77, Sample 4.”**

504.64 Non Destructive Testing-Ancillary Bridge Products and Support Structures Revise the first sentence under number 1 by adding **“fillet or partial penetration welds on”** between the words “of” and “each” so the first sentence reads “Examine ten percent of fillet or partial penetration welds on each production lot using Magnetic Particle (MT) inspection”.

SECTION 506 **SHOP APPLIED PROTECTIVE COATING - STEEL**

Revise this section by removing the subsection THERMAL SPRAY COATING entirely and replace with: THERMAL SPRAY COATING

506.30 Description This work shall consist of surface preparation and application of Thermal Spray Coatings (TSC) in accordance with the Plans and this Specification. Application of TSC to steel substrate shall be done in accordance with requirements, recommendations and appendices of the current Joint Standard *NACE NO. 12/AWS C2.23M/SSPC-CS 23.00, Specification for the Application of Thermal Spray Coatings (Metallizing) of Aluminum, Zinc, and Their Alloys and Composites for the Corrosion Protection of Steel* (The Standard) and this Specification.

The applicator shall have a minimum of five years of experience and shall provide copies of application procedures, operator qualifications, QC Manuals and repair procedures.

506.31 Submittals Submit an application procedure and QC Plan for review by the Department prior to beginning work. Submit a certified analysis of the feedstock to the Department. Submit sample copies of QC records for review. Submit copies of applicator qualifications, job history, etc. Provide the name and qualifications of the QCI.

506.32 Surface Preparation Prior to abrasive blast cleaning, round all corners exposed in the assembled product to approximately a 3/32 inch radius. A series of tangents to the approximate radius will be considered acceptable. Remove hardened condition on thermal cut surfaces. Abrasive blast clean all surfaces to be coated in accordance with The Standard and *SSPC-SP 5, White Metal Blast Cleaning* (SP 5). Use SSPC-VIS. 1 as a visual standard to determine acceptable cleanliness. Inspect the substrate immediately before spray application.

The anchor profile shall be per The Standard (minimum 2.5 mils). Measure and record the anchor profile in accordance with *ASTM D4417 Method B or C (Replica Tape) or both* on each plane to be sprayed or at 120 ° intervals on pipe or tube. Measure at the frequency in The Standard. Angular blast media shall conform with The Standard. If the anchor profile fails to meet the minimum required profile, re-blast the substrate until the required anchor profile is achieved.

If compressed air is used for abrasive blast cleaning, perform a blotter test in accordance with *ASTM D4285* at the beginning of each shift. Empty moisture traps at the beginning of each shift and at any time thereafter when moisture appears to be present on the substrate. Notify the QAI prior to performing the test in order that the QAI can witness the blotter test.

506.33 TSC Requirements The coating thickness shall be a minimum of 14 mils. The DFT on faying surfaces shall not exceed the thickness tested for Class B slip coefficient rating. The TSC shall have a minimum tensile bond per The Standard. Test the tensile bond in accordance with *ASTM D4541*. The frequency of testing shall be per The Standard. The test

location will be as directed by the QAI. The specified tensile force shall be applied to the TSC and removed. If the test does not reveal a failure of the TSC, the tensile bond shall be considered acceptable. Repair or recoat unacceptable work. Tensile testing may be performed on witness panels coated by each technician on each shift TSC is applied; notify the QAI so witness panel coating may be observed.

Perform a bend test as described The Standard, at the beginning of each shift. If the bend test fails, take corrective action and perform another test. After performing the bend test successfully a number of times, the Fabrication Engineer may reduce the frequency of testing. Document the results of the tensile bond test and bend test and provide the results to the Department. Satisfactory bend test results with 7-12 mils thickness will be acceptable.

The TSC shall have a uniform appearance, free from blistering, cracks, loose particles, or exposed steel substrate when examined with 10-X magnification.

506.34 TSC Application Record the batch and lot numbers of the consumables. Measure the environmental conditions in the immediate vicinity of the piece(s) being coated during the coating operation and during the entire cure period for intermediate and top coat. Provide two data loggers capable of measuring ambient humidity and temperature. The data loggers shall come with software that can download the data onto a computer. Print out the data and provide a copy to the QAI for review prior to applying the subsequent coat of paint. Place the data loggers in the immediate vicinity of the coating operation during the entire application and curing cycle. The data will be used to determine that the cure/recoat time requirements for each coat have been met. Failure to comply will result in the coating being cured for the maximum time necessary to assure adequate cure as determined by the Fabrication Engineer.

506.35 Seal Coat and Top Coat Application (Paint) Apply a wash primer and/or seal coat of 2 to 3 mils thickness. The seal coat shall be compatible with an epoxy intermediate coat and a polyurethane top coat from the NEPCOAT QPL. Provide certification of compatibility between the seal coat and intermediate coat from the intermediate coat/top coat manufacturer. Top flanges of beams requiring shear connectors shall receive a seal coat only.

506.36 Materials Provide materials in accordance with 506.11.

506.37 Mixing and Application Mix and apply in accordance with 506.14.

506.38 Dry Film Thickness Measure and record the DFT in accordance with 506.15.

506.39 Touch-up and Repairs Repair damage to TSC by re-blasting the damaged area and re-applying TSC in accordance with this Specification. Perform touch-up and repairs to paint in accordance with 506.16.

SECTION 507 **RAILINGS**

507.07 Aluminum Bridge Railing Amend the paragraph beginning with “Welding shall be done in conformance...” by adding after “Aluminum D1.2” the words “(AWS D1.2)”. Add the following as a new paragraph after this paragraph:

“All welds shall be inspected and conform with AWS D1.2, Clause 5, Inspection. 100% of welds shall be visually examined (VT). In addition to VT, 10% of all partial joint penetration (PJP) and fillet welds shall be dye penetrant tested (PT); locations to be PT examined will be designated by the QAI. 25% of complete joint penetration (CJP) welds shall be either, ultrasonic tested (UT) or PT based on the thinner material in the welded joint; joints with thinner material thicknesses less than 0.25 inch shall be PT examined and joints with thinner material thickness equal or greater than 0.25 inch shall be UT examined. Locations to be UT examined will be designated by the QAI. Extent of testing shall conform with AWS D1.2, Clause 5.”

SECTION 510 **SPECIAL DETOURS**

510.032 Geometric and Approach Design a. Horizontal alignment
The third paragraph of this section is revised to read as follows:

“The roadway width shall be increased on curved portions of the Special Detour to account for the off tracking characteristics of WB-62 vehicle in accordance with the AASHTO publication A Policy On Geometric Design of Highways and Streets (the Green Book), chapter 3 table entitled Design Widths of Pavements for Turning Roadways.”

SECTION 527 **ENERGY ABSORBING UNIT**

527.02 Materials This section is revised to read as follows.

527.02 Materials Work Zone Crash Cushions must comply with NCHRP Report 350. Work Zone Crash Cushions shall be selected from MaineDOT’s Qualified Products List of Crash Cushions / Impact Attenuators, or an approved equal.

SECTION 534 **PRECAST STRUCTURAL CONCRETE**

534.14 Process Control Test Cylinders
Revise this subsection to read:

“534.14 Acceptance and Quality Control Testing of Concrete Refer to Section 712.061.”

534.20 Installation of Precast Units revise this section by removing the first two paragraphs and replacing them with:

534.20 Installation of Precast Units When footings are required, install the precast units on concrete footings that have reached a compressive strength of at least 3,000 psi. Construct the completed footing surface to the lines and grades shown on the Plans. When checked with a 10 foot straightedge, the surface shall not vary more than one-quarter inch in 10 feet. The footing keyway shall be filled with a Department-approved non-shrink flowable cementitious grout with a design compressive strength of at least 5,000 psi.

Three sided frame and box culvert joints shall be sealed with a Department-approved flexible joint sealant in accordance ASTM C990. Joints shall be closed tight. Culvert units shall be equipped with joint closure mechanisms to draw units together and close joints to the required opening.

SECTION 535 **PRECAST, PRESTRESSED CONCRETE SUPERSTRUCTURE**

Section 535.08 – Quality Assurance

Revise the second paragraph to read:

“The QAI will perform acceptance sampling and testing and will witness or review documentation, workmanship and testing to assure the Work is being performed in accordance with the Contract Documents.”

Section 535.15 - Process Control Test Cylinders

Revise the first paragraph to read:

“535.15 Acceptance and Quality Control Testing of Concrete Acceptance of structural precast/prestressed units, for each day’s production, will be determined by the Department, based on compliance with this specification and satisfactory concrete testing results. At least once per week, the QAI will make 2 concrete cylinders (6 cylinders when the Contract includes permeability requirements) for use by the Department; cylinders shall be standard cured in accordance with AASHTO T23 (ASTM C31). The QAI will perform entrained air content and slump flow testing, determine water-cement ratio and determine temperature of the sampled concrete at the time of cylinder casting. All testing equipment required by the QAI to perform this testing shall be provided in accordance with Standard Specification Section 502.041, Testing Equipment. In addition, the Contractor shall provide a slump cone meeting the requirements of AASHTO T 119. Providing and maintaining testing and curing equipment shall be considered incidental to the work and no additional payment will be made.”

Insert the following as the second paragraph of Section 535.15:

“Quality Control concrete test cylinders shall be made for each day’s cast and each form bed used. Cylinders tested to determine strand release strength and design strength shall be field cured in accordance with AASHTO T23 (ASTM C31). 28 day cylinders shall be standard cured. Record unit identification, entrained air content, water-cement ratio, slump flow and temperature of the sampled concrete at the time of cylinder casting.”

SECTION 603

PIPE CULVERTS AND STORM DRAINS

603.02 Materials Amend this section by adding the following two paragraphs to the end:

“Reinforced Concrete Pipe (RCP) with inside diameters of 10 ft. (120in) or greater shall be designed, fabricated and accepted in accordance with Section 534- Precast Structural Concrete.

All Pipes or Culverts with inside diameters of 10 ft. (120in) or greater shall be designed using the current version of the AASHTO LRFD Bridge Design Specifications with Maine Modified HL-93 for Strength 1.”

SECTION 604

MANHOLES, INLETS CATCH BASINS

604.04 Adjusting Catch Basins and Manholes,

Add the following paragraph to the end of 604.04 b:

The Department will allow the use of metal ring inserts set into the manhole top frame or composite risers placed beneath the manhole frame to adjust manhole slope and grade for paving projects. The use of metal ring inserts shall be in accordance with 604.04 d. Ring Insert Requirements. The use of composite risers shall be in accordance with 604.04 e. Composite Riser Requirements.

Add the following paragraph after the first paragraph of 604.04 c:

The Department will allow the use of metal ring inserts set into the manhole top frame or composite risers placed beneath the manhole frame to adjust manhole slope and grade for paving projects. The use of metal ring inserts shall be in accordance with 604.04 d. Ring Insert Requirements. The use of composite risers shall be in accordance with 604.04 e. Composite Riser Requirements.

Add the following sections to 604.04:

d. Ring Insert Requirements Ring inserts to adjust manhole top frame slope and grade will be allowed in accordance with the following requirements:

1) Materials

- i. All ring inserts must be made of iron. *Multiple ring inserts will not be allowed.* The single ring insert may be any height up to a maximum of 2 inches tall.**

- ii. Ring inserts shall not be welded to the manhole frame to prevent brittle failure of the cast iron frame.
- iii. Ring inserts shall be fastened to the manhole frame using liquid steel-filled epoxy such as Loctite Fixmaster Steel Liquid or equivalent. The epoxy shall be installed in accordance with the manufacturer's recommendations.

2) Where Ring Inserts May/May Not Be Used

- i. MaineDOT will allow the use of a single manhole ring insert to raise manholes on state and state-aid highways.
- ii. *Manhole ring inserts may not be used along state and state-aid highway sections where the speed limit is 40 miles per hour or more.* The standard brick and mortar or flat composite risers beneath the manhole frame must be used at these locations.

3) Construction Requirements For The Use of Iron Manhole Ring Inserts

- i. Wherever iron ring inserts are used to raise manhole top elevations, the rings shall be fastened to the existing manhole frame using liquid steel-filled epoxy. The liquid steel-filled epoxy shall be placed evenly around the entire manhole frame before placing the ring insert. *Unbonded ring inserts will not be allowed.* If the manufacturer's recommended construction practices result in loose or unacceptable manhole cover restraint, standard brick and mortar or flat composite risers beneath the manhole frame must be used at these locations.

e. Composite Riser Requirements Flat or beveled, doughnut-shaped, composite risers placed beneath the manhole frame to adjust slope and grade are allowed. The composite riser shall be fastened to both the top of the concrete cone and bottom of the manhole frame with the manufacturer's recommended epoxy. Composite risers may be used at all locations on state and state-aid highways under any legal speed limit without restriction.

SECTION 606
GUARDRAIL

606.09 Basis of Payment Amend the first sentence of the eighth paragraph of this subsection by removing the word "meter" and replace it with "linear foot".

SECTION 608
SIDEWALKS

608.021 Sidewalk Materials Revise this section by removing the second paragraph which begins with “Portland cement concrete shall...” in its entirety and replace with “**Portland cement concrete shall be Class A and meet the requirements of Section 502, Structural Concrete.**”

SECTION 609
CURB

609.03 Vertical Stone Curb, Terminal Section and Transition Sections and Portland Cement Concrete Curb, Terminal Sections and Transition Sections

Amend this section by adding the following paragraph to the end of it:

“The Contractor may elect to substitute concrete to backfill Stone Curbing or Stone Edging at their option. If the concrete backfill option is elected, the following is added to Standard Specification 609 – Curb”

609.02 Materials Amend this section by adding the following to it:

Portland cement and Portland Pozzolan Cement	701.01
Water	701.02
Fine Aggregate for Concrete	703.01
Coarse Aggregate for Concrete	703.02

The Contractor shall submit a concrete mix design for the Portland Cement Concrete to the Resident, with a minimum designed compressive strength of 3000 psi Class Fill concrete.

609.10 Basis of Payment Revise by changing the fifth paragraph which begins with “There will be no separate payment...” this section by removing the word “cement” and replacing it with “**concrete fill, mortar**”.

SECTION 619
MULCH

619.07 Basis of Payment Amend this section by adding the words “**; Bark Mulch and Erosion Control Mix will be paid for by the Cubic Yard;**” into the first sentence so that it reads:

“The accepted areas mulched will be paid for at the contract price per unit; **Bark Mulch and Erosion Control Mix will be paid for by the Cubic Yard;** which shall be full compensation for furnishing and spreading the hay or straw and mulch binder, cellulose fiber mulch, bark mulch or erosion control mix.

Revise the second sentence by removing “**for pay item 619.1201**” So that it reads:

“When Mulch is measured in Bales, each bale will be paid for at 60% of the contract price per Unit”.

Revise this section by removing all pay items and replace them with the following:

619.12 Mulch	Unit
619.13 Bark Mulch	Cubic Yard
619.14 Erosion Control Mix	Cubic Yard

SECTION 621 **LANDSCAPING**

621.0002 Materials - General

In the list of items change “Organic Humus” to “**Humus**”.

621.0019 Plant Pits and Beds

c Class A Planting

In the third paragraph beginning with “ The plant pit...” change “½ inch” to “**1 inch**”

SECTION 626 **FOUNDATIONS, CONDUIT AND JUNCTION BOXES FOR HIGHWAY SIGNING, LIGHTING AND SIGNALS**

626.02 General Amend the Material list by adding the following to the list:

Gravel Borrow	703.20
---------------	--------

Revise the Material List by removing:

Prewired Conduit	715.04
Metallic Junction and Fuse Box	715.05

626.021 Miscellaneous Material Amend this section by adding the following to the end of it:

“All concrete for concrete encasement of conduit shall be Fill Class concrete in accordance with the applicable requirements of Section 502 – Structural Concrete.”

Amend the third paragraph that begins with “If grouting is necessary...” by adding “**included on the Qualified Product List and**” after the word “material”.

626.03 General Amend this section by adding the following section to the end of it

“626.0301 Electrical Supply Lines and Service Connections The following requirements shall apply to Electric Supply Lines and Service Connections feeding traffic signalization equipment control boxes and lighting breaker boxes.

Whenever possible, the meter and breaker panel feeding traffic signal control boxes or lighting control boxes shall be constructed within 30 feet of the service drop pole.

All underground service connections that are constructed in trenches and carrying Secondary Utility Power to a MaineDOT meter and breaker panel, or, directly to MaineDOT traffic signalization control cabinets or lighting breaker boxes shall be in Rigid Metal Conduit or concrete encased PVC conduit.

Where trenchless technologies are employed to install the service connection conduit, Schedule 120 PVC conduit shall be used for the trenchless bore section of conduit. In addition, concrete encasement shall be used for any PVC conduit placed in trench sections and carrying Secondary Utility Power more than 10 feet before or after the limits of the trenchless bore conduit.

The construction practices described above shall be used for service connections up to a maximum of 600 feet. There may be rare exceptional cases where the service connection must exceed 600 feet. In these cases, the power companies may require primary power be run over 600 feet for the purpose of power consumption and dependable service. These cases will be evaluated on a case-by-case basis for alternate power feed methods and/or the need for steel or concrete encased conduit.”

626.031 Conduit Revise this section by removing the second paragraph which begins with “Trenches for conduits...” and replace it with the following:

“Trenches for conduits shall be excavated to a width that will permit proper installation of the conduit and to a minimum depth of 3 feet below finish grade as measured from the top of the conduit. If deeper depths are required, the conduit shall be installed at the depth shown on the plans or as directed. Conduit shall not interfere with poles, guardrail posts, sign foundations or other objects.”

Amend the third paragraph which begins with “All junction or pull boxes...” by adding “concrete, in accordance with the applicable requirements of Section 502 – Structural Concrete,” after Class LP.

Revise the fifth paragraph which begins with “After the trench has been...” by adding the following to the end of it:

“Where concrete encasement is required around the conduit, backfilling with approved material may begin adjacent to and above the encased conduit no sooner than 24 hours after concrete placement.”

Remove the following:

“All underground conduit shall be placed to at least the depth shown on the plans and shall not interfere with poles, guardrail posts, sign foundations or other objects.”

Revise the paragraph beginning with “All conduit ends shall...” by removing “Prewired Conduit shall be sealed during construction to prevent entry of moisture, dirt, or rocks.”

626.033 Polyvinylchloride Conduit Installation Amend the first paragraph of this section which begins with “Polyvinylchloride conduit and High Density...” by adding the following to the end of it:

“In addition, PVC conduit used for Electrical Supply Lines and Services constructed as underground service connections in trenches and carrying Secondary Utility Power to a MaineDOT meter and breaker panel, or, directly to MaineDOT traffic signalization control cabinets or lighting breaker boxes shall be concrete encased. When trenchless technologies are used to install PVC conduit, concrete encasement shall not be required.

Concrete encasement shall consist of a minimum of 4 inches of concrete above, below and on both sides of the conduit that shall have a minimum compressive strength of 3000 psi and a maximum aggregate size of 1-inch (Fill Class concrete). The concrete encasement may be backfilled no sooner than 24 hours after placement. “

“NON-METALLIC UNDER PAVEMENT CONDUIT INSTALLATION

Where noted on the drawings, non-metallic under pavement conduit of schedule 80 or greater rating shall be provided to facilitate conduit crossing of the existing highway and ramps without disruption to the existing highway and ramp pavement surface. The non-metallic under pavement conduit shall be hydraulically jacked or directional bored below the highway and ramp at a depth of not less than (36 inches). Under pavement conduit shall extend for a distance of (10 feet) beyond the highway or ramp edge at each side.”

Amend the sixth paragraph which begins with “Where PVC conduit runs are...” by changing “3 inch minimum bedding” to **“6 inch minimum bedding”**.

626.034 Concrete Foundations

Revise this section by removing the third paragraph which begins with “In the absence of Design Requirements...” in its entirety and replace with the following:

“In the absence of design requirements being provided on the plans, the Contractor shall prepare and submit the foundation design(s) to the Department for review. The Contractor may propose an alternate shallow spread footing or drilled shaft configuration/design than that set forth on the drawings. Design shall be in accordance with AASHTO LRFD Specifications for Structural Supports for Highway Sign, Luminaires and Traffic Signals, current edition; AASHTO LRFD Bridge Design Specifications, current edition; and FHWA-NHI-10-016 Drilled Shafts, Construction Procedures and Design Methods, current edition. Where conflicting requirements occur, the more stringent requirements shall govern. In addition to other design requirements, foundation design shall account for Torsion for which a

minimum Factor of Safety equal to 1.2 shall be achieved. In evaluating axial capacity and torsional resistance in cohesionless soils, load transfer coefficient or side resistance coefficient (beta, β) will be used in accordance with Subsection 13.3.5.1 of FHWA-NHI-10-016, with beta determined in accordance with Equations 13-13 and 13-11 for silty sands to sandy silts (with varying amounts of gravel). The design criteria for the resistance of drilled shaft and spread footing foundations against overturning, sliding and bearing capacity failure shall meet the requirements of Section 4 of AASHTO LRFD Bridge Design Specifications, current edition. The structural design of foundations shall meet the requirements of AASHTO LRFD Bridge Design Specifications, current edition. The Contractor shall submit to the Department for review, three (3) copies of detailed plans and calculations of the proposed design. Design shall be prepared and sealed by a Professional Engineer licensed in the State of Maine. Construction of foundation(s) shall not commence until the Department has reviewed the foundation design.”

On Page 6-85, add the following paragraph before the paragraph beginning with “Drilled shafts shall not be...”.

“ No foundation design will be required for 18- and 24-inch diameter foundations for structures less than 30-feet tall and with no projecting arms. A foundation design prepared by a Professional Engineer licensed in accordance with the laws of the State of Maine will be required for all other foundations. Precast foundations will be permitted for 18 and 24-inch diameter foundations for structures less than 30-feet tall and with no projecting arms. Where precast foundations are permitted flowable concrete fill shall be used as backfill in the annular space, and placed from the bottom up. Construction of precast foundations shall conform to the Standard Details and all requirements of Section 712.061 except that the concrete shall have a minimum permeability of 17 kOhm-cm and the use of calcium nitrite will not be required. “

On Page 6-86, Revise the paragraph beginning with “Concrete for drilled shafts...” so that a portion of it reads as follows:

“...The Contractor shall provide temporary dewatering of excavations for foundations such that concrete is placed in the dry. Concrete for drilled shafts shall be placed in accordance with Section 502.10 as temporary casing is withdrawn to prevent debris from contaminating the foundation and to ensure concrete is cast against the surrounding soil. Concrete for drilled shafts and spread footings shall be Class LP in accordance with Section 502 - Structural Concrete. Precast foundations will not be permitted except as specified above in this Section. Backfill for spread footing foundations shall be Gravel Borrow meeting the requirements of Section 703.20 - Gravel Borrow.....”

626.05 Basis of Payment Amend this section by removing the following paragraphs:
The one which starts with “Payment will be made for the total number of linear feet of prewired conduit...”

The one which starts with “Prewired conduit within the foundations...”

Amend this subsection by adding the following paragraph and Pay Items:

“Payment will be made for the total number of linear feet of under pavement conduit actually furnished, installed and accepted at the contract price per linear foot. This price shall include the cost of: furnishing and installing the conduit; excavating; furnishing special backfilling materials, pull wire, fittings, grounding and bonding; test cleaning interiors of conduits and all materials, labor, equipment and incidentals necessary to complete the work.”

Pay Item	PayUnit
626.221 Non-metallic Conduit, Concrete Encased	Linear Foot
626.251 Non-Metallic Under pavement Conduit (Schedule 80 or greater rating)	Linear Foot

Remove the following Pay Items:

626.23 Prewired Conduit Secondary Wiring	Linear Foot
626.24 Prewired Conduit Primary Wiring	Linear Foot

SECTION 627 **PAVEMENT MARKINGS**

Revise this section by removing it in its entirety and replacing with the following:

627.01 Description This work shall consist of furnishing and placing reflectorized pavement lines and markings, removing pavement lines and markings, and furnishing and applying reflectorized paint to curbing in reasonably close conformity with the plans and as designated.

627.02 Materials Materials shall conform to the requirements specified in the following Sections of Division 700 - Materials.

Pavement Marking Paint	708.03
Reflectorized Plastic Pavement Marking	712.05

Temporary Bi-directional Yellow Delineators shall be Temporary Object Markers (T.O.M.) as manufactured by the Davidson Plastic Company, 18726 East Valley Highway, Kent, WA 98031 or an approved equal.

627.04 General All pavement lines and markings shall be applied in accordance with the latest edition of Manual on Uniform Traffic Control Devices.

Longitudinal lines placed on tangent roadway segments shall be straight and true. Longitudinal lines placed on curves shall be continuous smoothly curved lines consistent with the roadway alignment. All pavement markings placed shall meet the tolerance limits shown on the plans.

Unless otherwise shown on the plans, non-interstate lines shall be 4 inches wide and broken lines shall consist of alternate 10 foot painted line segments and 30 foot gaps. On controlled access divided highways and on the interstate system lines shall be 6 inches wide and broken lines shall consist of alternate 15 foot painted line segments and 25 foot gaps. Width tolerance shall be +/- 1/4 inch.

Temporary pavement marking lines, defined in Special Provision Section 652, Maintenance of Traffic, Temporary Centerline, will be applied as many times as necessary to properly delineate traffic lanes for the safe passage of traffic. Bi-directional delineators may be used in place of temporary lines, except where specified otherwise in Special Provision 652 Maintenance of Traffic, Temporary Centerline. Delineators will be applied at 40 foot intervals.

In overnight lane closure areas that are not to be overlaid, temporary plastic lines or raised pavement markers shall be used through the length of the taper.

Newly painted lines, markings and curb shall be protected from traffic by the use of cones, stationary vehicles or other approved methods until the paint is dry.

627.05 Preparation of Surface Immediately before applying the pavement marking paint to the pavement or curb, the surface shall be dry and entirely free from dirt, grease, oil, or other foreign matter.

Surface preparation for application of plastic markings shall conform to the manufacturer's recommendations.

627.06 Application Prior to applying paint for final pavement lines, the Contractor shall perform a test for paint thickness by furnishing and placing a piece of smooth, clean metal with an area of at least 144 in² in the path of the striping truck. The striping truck shall be passed over the piece of metal, painting the surface as it passes, without applying beads. The result of this test will be used to determine the pressure setting and speed of the truck when applying paint to obtain the specified thickness. Additional paint thickness testing may be required on the final paint markings. The wet thickness of paint without beads on final pavement lines shall be a minimum of 16 mils.

On other final pavement markings and on curb, where the paint is applied by hand painting or spraying, application shall be in two uniform covering coats, each at least 10 mils thick. Before the second coat of paint has dried, the glass beads shall be applied by a pressure system that will force the glass beads onto the undried paint as uniformly as possible.

Glass beads shall be applied to the final and temporary pavement lines, marking and curb at a sufficient rate and in sufficient quantity to assure complete and uniform coverage of hand painted surfaces and achieve proper reflectivity.

Permanent and temporary white lines and markings shall have a minimum final reflectivity value of 250 millicandelas per square meter per lux (mcd/m²/lux) and permanent and temporary yellow lines and markings shall have a minimum final reflectivity value of 150

millicandelas per square meter per lux (mcd/m²/lux), as measured by the Department. Measurements taken to determine reflectivity shall be done within 4 weeks after final placement.

If the final reflectivity values are less than the described minimums, the Contractor shall repaint those areas not meeting required reflectivity at no cost to the Department. If the final reflectivity values are less than the described minimums after the second attempt, the Contractor will submit in writing a plan of action to meet the reflectivity minimums prior to continuing any work. Once the plan has been reviewed and approved by the Department, the Contractor shall re apply at no cost to the Department.

Temporary painted lines and markings shall be applied as specified for permanent painted lines, except that the thickness shall be a minimum of 16 mils.

Temporary pliant polymer marking material shall be used for temporary markings on the final pavement and on pavements not to be resurfaced when such pavement markings do not conform to the final pavement markings pattern.

The plastic final pavement lines and markings shall be applied in accordance with the manufacturer's recommendations by the inlay method of application.

627.07 Establishment Period Inlaid plastic pavement lines and marking material furnished and installed under this contract for final pavement markings shall still be subject to a six-month period of establishment.

The period of establishment shall commence as soon as the plastic pavement lines and markings are complete and in place and shall continue for six months. At the end of the establishment period, a minimum of 95% of the plastic pavement lines and markings shall still be in place to be acceptable.

If less than 95% of the plastic pavement lines and markings are in place after six months, the Contractor shall replace all unsatisfactory plastic pavement lines and markings on the project without additional payment. Plastic pavement lines and markings designated for replacement shall be installed according to these specifications, unless otherwise directed. Plastic pavement lines and markings replaced at the end of the six month establishment period will not be subject to a further establishment period.

627.08 Removing Lines and Markings When it is necessary to remove pavement lines and markings, it shall be done by high pressure water, grinding or other approved acceptable means. The method chosen must be capable of completely eradicating the existing line or marking without excessive damage to the pavement. Burning and the use of solvents to remove temporary markings from final pavement or from existing pavement not to be resurfaced will not be permitted.

627.09 Method of Measurement The quantity of pavement marking lines identified in the contract as a plan quantity pay item, the measurement of payment will be the number of

feet shown in the Schedule of Items. This quantity will be considered final and no adjustments will be made except when changes resulting in increases or decreases are made by the Resident.

The accepted quantity of temporary or permanent pavement marking lines when identified in the contract as a linear foot item shall be measured and paid for at the contract unit price per linear foot for the total amount applied and accepted.

Double yellow centerline, broken or solid, will be considered one line for measurement purposes. The measurement of broken lines will include the gaps when painted and will not include the gaps when plastic. Double Yellow Centerline, broken or solid shall not be paid through intersections or side roads and will be paid for the actual length of painted line.

Broken white lines will include the gaps when painted and will not include the gaps when plastic inlaid pavement lines are applied. Yellow or white solid edge lines and will not be paid through intersections or side roads and will be measured by the actual length of painted line.

Temporary pavement marking lines shall not be paid through intersections or side roads and will be measured per linear foot of actual length of painted and accepted.

Reflectorized curb will be measured or computed by the square foot of curb surface actually painted and reflectorized.

The accepted quantity of removing existing pavement markings will be measured by the square foot.

Temporary Bi-directional Yellow Delineators will be measured by each unit, complete in place, maintained, and accepted.

627.10 Basis of Payment The accepted quantity of pavement marking lines identified in the contract as a plan quantity pay item will be paid for at the contract unit price for plan quantity. No adjustment will be made to the quantity for payment, except as described 627.09 Method of Measurement

The quantity of permanent or temporary pavement marking lines identified in the contract paid by the linear foot will be measured for payment as described under section 627.09 Method of Measurement.

All other permanent pavement markings will be paid for at the contract unit price per square foot in accordance with 627.09 Method of Measurement.

If allowed by Special Provision, the Contractor may utilize Temporary Bi-Directional Yellow and White (as required) Delineators. When utilized, payment will be made as temporary pavement marking lines, measured and paid at the contract unit price per linear foot. Such payment will include as many applications as required and removal.

Payment for final plastic pavement lines and markings will be made in two parts. The first payment of 75% will be made when plastic pavement lines and markings are placed. The payment of the remaining 25% will be made at the end of the establishment period for all plastic line and pavement markings accepted.

The accepted quantity of any pavement marking lines will be paid for at the contract unit price and will include as many applications as required and removal when required.

The accepted quantity of Temporary Bi-directional Yellow Delineators will be paid for at the contract unit price.

Payment will be made under:

<u>Pay Item</u>	<u>Pay Unit</u>
627.18 12 inch Solid White Pavement Marking Line	Linear Foot
627.711 White or Yellow Pavement Marking Line - Plan Quantity	Linear Foot
627.733 4" White or Yellow Painted Pavement Marking Line	Linear Foot
627.744 6" White or Yellow Painted Pavement Marking Line	Linear Foot
627.75 White or Yellow Pavement & Curb Marking	Square Foot
627.77 Removing Existing Pavement Marking	Square Foot
627.78 Temporary 4" Painted Pavement Marking Line, White or Yellow	Linear Foot
627.781 Temporary 6" Painted Pavement Marking Line, White or Yellow	Linear Foot
627.407 Reflectorized Plastic, White or Yellow Pavement Marking	Square Foot
627.4071 Reflectorized Plastic, White or Yellow Pavement Marking Line - Plan Quantity	Linear Foot
627.811 Temporary Bi-directional Yellow Delineators	Each

SECTION 634 HIGHWAY LIGHTING

Revise this section by removing this section in its entirety and replace with the following:

634.01 Description This work shall consist of furnishing and installing a highway lighting system or modifying or removing an existing highway lighting system, including the design of Light Standards, in accordance with these specifications and in reasonably close conformity with the plans.

634.02 General All material furnished by the Contractor shall be new unless otherwise specified. Substitutes for specified material may be accepted, upon approval of the Fabrication Engineer. Substitutes shall provide equal or better service. Where an existing system is to be modified, the existing material shall be removed, upgraded, or disposed of as shown on the plans or as directed.

All electrical equipment shall conform to NEMA, UL, or EIA standards, wherever applicable. In addition, all materials and workmanship shall conform to the requirements of the NEC, the local electrical Utility Company, and all local ordinances, which may apply.

634.021 Materials Materials shall meet the requirements specified in the following Section of Division 700 - Materials:

Steel Conduit	715.02
Non-metallic Conduit	715.03
Prewired Conduit	715.04
Metallic Junction and Fuse Box	715.05
Secondary Wiring	715.07
Luminaires, Lamps and Ballast	715.08
Luminaires, Lamp and Ballast for High Mast Lighting	715.09
Photo Electric Control	715.10
Service Equipment	715.11
Lowering System for High Mast Lighting	715.12
Aluminum Supports	720.01
Aluminum Mast Arm and Bracket Arm	720.02
Steel Supports	720.03
Steel Mast Arm and Bracket Arm	720.04
High Mast Light Standard	720.05
Steel H-beam Poles	720.06
Anchor Bolts	720.07
Wood Ornamental Light Standard	720.09
Wood Utility Pole	720.10
Mast Arm for Wood Utility Pole	720.11
Breakaway Devices	721.01

Transformer enclosures shall conform to NESC requirements. They shall be approximately 46 inches high, 42 inches wide and 42 inches deep. Dimensions should be verified with the electrical Utility Company before ordering. Clearances shall be provided as required by the NESC. The enclosure shall be painted inside and outside with one coat of red iron-oxide primer and a finish coat of gray baked enamel. Doors shall be furnished with padlock lugs.

The electric portable power unit shall be a heavy-duty reversing electric motor for the voltage and frequency shown on the plans and shall have a remote control.

The following are the minimum requirements for the high mast lighting lowering system:

- Ball bearing motor
- Grounded frame
- Torque limiter
- Power unit mounting frame

**Coupling to winch drive shaft
Remote control unit with cable
Cable with twist lock receptacle and plug for operator of power unit**

All bolts for mounting lighting fixtures under bridge structures shall conform to the requirements of ASTM A307. These bolts and other fastening hardware shall be hot-dipped galvanized in accordance with ASTM A153.

Screened sand for bedding and covering direct buried cables shall meet the requirements of Section 703.14, except that there shall be 0-10% passing the No. 200 sieve.

634.022 Equipment List and Drawings Unless otherwise permitted in writing, the Contractor shall submit for review a list of equipment and materials which is proposed to be furnished. The list shall include the name of manufacturer, size, and identifying number of each item and other necessary data, including detailed scale drawings, wiring diagrams of special equipment and any proposed minor deviations from the plans. If requested, the Contractor shall submit sample articles of the material proposed for use. All of the above data except sample articles, shall be submitted in duplicate. Following checking, correction, and approval, not less than two complete sets of approved drawings shall be submitted. The Department will not be liable for material purchased, labor performed, or work delayed before such review. Where electrical equipment is to be constructed as shown on the plans, the submission of detailed drawings and diagrams will not be required.

Upon completion of the work, the Contractor shall submit three complete sets of corrected plans showing all construction changes.

634.023 Miscellaneous Material Insulating tape shall be of the self-bonding type. Jacket tape shall be of the water-resisting type. Friction tape shall be rubber-impregnated, woven cotton fabric.

634.024 Light Standards The terms "conventional standard" or "conventional light standard" shall mean the assembled metal base flange, transformer base or breakaway device, metal columnar shaft, metal overhanging bracket arm and incidental hardware.

The term "high mast pole" shall mean the assembled base plate flange, metal columnar shaft, luminaire tenon, mounting and lowering device and incidental hardware. For purposes of this specification, a structure shall be considered a high mast pole if the pole height, from base plate to the center of the luminaire, exceeds 55 feet.

The design, materials and fabrication of Light Standards shall meet the requirements of the current edition of AASHTO "LRFD Specifications for Structural Supports for Highway Signs, Luminaires, and Traffic Signals" and interims thereto, as noted below except as otherwise indicated within these specifications or on the plans.

Light Standards with a luminaire mounting height in excess of 55 feet (high mast pole) shall be designed using the following criteria:

- **Basic wind speeds based on a 1700-year mean recurrence interval**
- **K_z as specified in Table C3.8.4-1 (Height and Exposure Factors)**
- **K_d as specified in Table 3.8.5-1 (Directionality Factors)**
- **G as 1.14, minimum (Gust Factor)**
- **C_d as specified in Table 3.8.7-1 (Wind Drag Coefficients)**
- **Fatigue Importance Category I with V_{mean} having a range of $9 \text{ mph} < V_{\text{mean}} \leq 11 \text{ mph}$.**

Light Standards with a luminaire mounting height of 55 feet or less shall be designed using the following criteria:

- **Basic wind speeds based on a 700-year mean recurrence interval**
- **K_z as specified in Table C3.8.4-1 (Height and Exposure Factors)**
- **K_d as specified in Table 3.8.5-1 (Directionality Factors)**
- **G as 1.14, minimum (Gust Factor)**
- **C_d as specified in Table 3.8.7-1 (Wind Drag Coefficients)**
- **Fatigue analysis is not required**

For structural design purposes the luminaire mounting height for roadside installation is defined as the distance from the center of luminaire to the base plate bottom. For Light Standards mounted on structures and approaches to structures, the luminaire mounting height shall be defined and measured as the distance of the center of the luminaire to one of the following:

- a. For bridges over bodies of water Above the prevailing water level or, in the case of tidal waters, above mean high tide.**
- b. For overpass structures Above the lower roadway level.**
- c. For approach ramps Above the average adjacent ground level, if said ground level is more than 10 feet below the base of the light standard.**

The design weight of luminaires shall be 60 pounds with an effective projected area of 2.5 ft², except that pole top-mounted luminaires shall have an effective projected area of 5.0 ft².

Light Standards mounted on a bridge structure or Light Standards fabricated with aluminum shall be equipped with an approved damping or energy-absorbing device.

Deflections of Light Standards and bracket arms shall be limited as follows:

- a. Conventional Light Standards shall be able to support a 500 pound transverse load, applied at 18 inches below the pole top with a maximum deflection of 5% of the nominal pole length. A computer simulation or detailed computation using Service I load combination (as specified in the AASHTO LRFD Specification for Structural Supports for Highway Signs, Luminaires, and Traffic Signals) establishing a maximum of 7% deflection of the nominal pole length may be used as an alternate method.**
- b. Bracket arms shall be able to support a horizontal load, perpendicular to the axial vector of the arm, of 50 pounds and a concurrent vertical load of 100 pounds, both loads applied at the luminaire tenon, without developing a measurable permanent set.**
- c. High mast Light Standards shall have a maximum deflection of 7% of the nominal pole length under full design load when equipped with four luminaires.**

Conformance to the above deflection criteria for Light Standards, bracket arms and high mast Light Standards shall be substantiated by detailed computations or computer simulation, accompanied by written methodology, or actual tests on materials produced for delivery under a Maine Department of Transportation contract.

The base plates of Light Standards shall have workable leveling nuts beneath and above them with flat washers against both nuts, when erected. The distance between the bottom of the base plate and top of the foundation shall not exceed twice the diameter of the anchor bolts. Grout, or other material, shall not be placed between the base plate and foundations.

Approval for deviations from the plans and/or specifications shall be requested in writing and shall be approved by the Fabrication Engineer before being incorporated in the manufacturer's drawings. Requests for substitution for all specified material shall be submitted in writing with full documentation (specifications, mill certifications, etc.) enabling the Department to evaluate the proposal.

A Certificate of Compliance shall be provided for all applicable materials noted in Section 634.021 – Materials, in accordance with the requirements of the General Statement of Division 700 Materials. Shop certification in accordance with Section 504.04 is required.

634.025 Conventional Light Standards After execution of the contract for conventional Light Standard(s), and before any shop work is commenced, the Contractor shall submit for approval the manufacturer's drawings of all standards and accessories proposed to be furnished and erected under this contract. The drawings shall be of sufficient detail to indicate material and/or dimensional conformance with these specifications and the plans. Each drawing shall contain a reference to the design criteria and certification that the design criteria have been met for the Light Standards, including bracket arms and associated hardware, fittings and breakaway devices, as submitted. A Professional Engineer licensed in accordance with the State of Maine regulations shall sign the certification under their official seal. The drawings shall use the same units as found in the project plans.

It is the intent of these specifications that the Contractor shall be fully responsible for the adequacy of the sizes, wall thickness, materials and connections of the Light Standards, including bracket arms and associated hardware, fittings and breakaway devices. Approval of the drawings will signify only approval of the material(s), mounting heights(s) and bracket arm length(s).

634.026 High Mast Light Standard For all high mast Light Standards, as defined in this Section, the Contractor shall submit for approval, in addition to the manufacturer's drawings, 3 sets of the design computations, including fatigue considerations consistent with AASHTO requirements. Approval of the drawings and computations will signify approval of all structurally significant details of the Light Standard and if any, the luminaire mounting and lowering device. All drawings and computations shall be signed by a Professional Engineer licensed in accordance with the State of Maine regulations. Approval will be based on the applicable provisions of Section 105.7.

The shaft shall be provided with an equipment access opening approximately 2 ft² and centered approximately 2 feet above the base. The access opening shall be reinforced to maintain the full design strength of the shaft and shall be provided with a hinged, removable, access door equipped with a vandal proof means of being locked in place. A positive means of internal grounding shall be provided inside of the access door.

All shaft sections shall be one plate thickness, except that a doubler plate may be used around the equipment access opening. The walls of polygonal shafts shall have an inside corner radius to wall thickness ratio not less than 2.

The Contractor may propose a galvanized and painted pole, in lieu of using weathering type steel. The steel shall be a base metal listed in the current edition of the AWS Structural Welding Code, D1.1. Paint color will be designated by the Fabrication Engineer. Galvanizing and surface preparation shall be in accordance with Section 504 and paint shall be a two-coat system designed for use on galvanized surfaces approved by the Engineer. The Contractor shall supply sufficient additional coating material and instructions for touchup work.

634.027 Breakaway Supports Breakaway supports, approved by the Engineer, shall be supplied for use at all locations designated as breakaway. Breakaway Support Certification of both breakaway and structural adequacy shall be provided by the Manufacturer. Design calculations or test data of production samples to support certification shall be provided. Breakaway support components shall provide the same or greater structural strength than the support post or pole utilizing the breakaway device. Breakaway couplings shall not be used in conjunction with transformer bases. Breakaway devices must include a reaction plate connecting all anchor bolts under the breakaway device. Poles containing conductors must contain a fusible breakaway device disconnecting all ungrounded conductors simultaneously

Breakaway devices are subject to the applicable provisions of Section 721 - Breakaway Devices.

634.03 General The location of the roadway lighting systems and other incidental work will be shown on the plans. They are diagrammatic only, but shall be followed as closely as actual conditions at the site and the work of other Contractors will permit. As the work progresses, the drawings may be revised or supplemented by the Resident, and the Contractor shall perform the work required by such revisions or supplements without additional compensation, except as provided in Section 109.

Work shall be scheduled to assure that each highway lighting system shall be completed and ready for operation upon completion of the corresponding section of the roadway or as specified in Special Provision 107.

Before proceeding with any work under this Contract, the Contractor shall conduct continuity and insulating tests to establish the integrity of cable runs already in place. The Contractor shall report all cable faults to the Resident. In cases faults are located while contract work is in progress and the Contractor does not report them, the Contractor will be responsible for correcting those faults without extra compensation.

634.031 Foundations Foundations for Highway Lighting shall meet the requirements of Section 626 – Foundations, Conduit, and Junction Boxes for Highway Lighting, Traffic Signals, and Highway Lighting.

634.04 Cable Installation The Contractor shall pull all wires through conduits without overstressing or stretching any wire or scoring, cutting, twisting or damaging the protective covering or insulation. When pulling cable into conduits, if the strain on the cables is likely to prove excessive, the Contractor shall use soapstone powder or listed cable pulling lubricant as a lubricant. Where two or more cables are to occupy the same conduit, they shall be drawn in together and kept parallel to each other by the use of a pulling head. No aluminum wire shall be installed underground for primary and secondary wiring.

Both ends of each length of cable shall be sealed to prevent the entrance of moisture during shipment or during outdoor storage. Defective and damaged cable will be rejected and shall be replaced at no cost to the State.

Secondary wiring shall be installed as shown on the plans. Secondary wiring shall not be spliced underground. Splicing shall only occur in above ground hand holes and transformer bases. The wire for secondary circuits, which is pulled through ducts, shall be fed slack from the feed end. Secondary wiring being pulled through a junction box shall be provided with enough slack for the center of the cable to be positioned a minimum of one (1) foot outside the top of the junction box

Cables in junction boxes shall be provided with enough slack for the center of the cable to be positioned a minimum of one (1) foot outside the top of the junction box and shall be arranged as directed. After cables have been installed, the end of each section of cable in Light Standards and panel boxes shall be carefully sealed with DAC Heavy Duty KWIK Foam Polyurethane Sealant, Minimum Expanding or an approved equal. Sealant shall penetrate a

minimum of four (4) inches into the conduit. All wiring shall be finished to provide a neat and orderly appearance. Ends of cable not connected to any device shall be insulated and sealed.

There will be no underground splicing of power conductors.

The trench for direct-buried cable shall be excavated to the width and depth shown on the plans or as directed.

Placement of the sand bedding shall be coordinated with the installation of the cables. After the cables and screened sand have been placed, the remainder of the trench shall be promptly backfilled with selected excavated material. Surplus material shall be disposed of as directed and the surface of the trench shall be loamed and seeded in accordance with Sections 615 and 618.

When connecting sockets, outlets and other similar equipment, the most accessible bare parts of each piece of equipment shall be connected to the grounded neutral. In order to ensure this has been done, each piece of equipment shall be tested after installation, under the supervision of the Resident, with a test lamp or other instrument, one leg of which has been connected to a definite ground, or by other approved means of testing.

All cables in junction boxes and Light Standards shall be tested for circuit connections, which shall be in conformity with those indicated on the plans. After verification of circuit connections, all cables in junction boxes, light standards and service panels shall be provided with individual metal tags, die-stamped with a phase designated A or B, as applicable. The tags shall be securely attached to the cables.

Splices to form continuous circuits shall be made by the Contractor and will only be permitted in accessible above ground locations. All other splices shall be made with approved crimp-type connectors.

Conductors shall not be pulled into conduit until pull boxes are set to grade, crushed rock sumps installed, grout placed around the conduit, concrete bottom of pull boxes placed and the metallic conduit bonded.

Where roadways are to remain open to traffic and existing lighting systems are to be modified, the existing lighting system shall remain in operation and the final connection to the modified circuit shall be made so that the modified circuit will be in operation by nightfall of the same day.

634.05 Erecting Light Standard To provide continuously aligned lamp post installations, Light Standards shall be located in accordance with the details governing the spacings and setbacks shown on the plans, unless otherwise directed.

The bracket arms shall be set normal to the edge of the roadway, unless otherwise directed. The bracket shall be assembled and attached to the shaft before the light standard is erected. If it is anticipated that there will be a period in excess of 24 hours between the erection of the

Light Standards and the installation of the luminaires, the Contractor shall install a weight, weighing between 50 to 75 pounds, at the outboard end of each bracket arm. This weight shall be designed and fastened in such a way that it will not pose a hazard to persons or vehicles passing beneath it.

Light Standards shall be erected in a vertical position, with a maximum deviation from the vertical of ¼ inch in 5 feet, using either the leveling nuts provided with the anchor bolts or the breakaway couplings. Once the Light Standard is in its final position, the top nuts shall be tightened as follows:

a. Anchor Bolts with Breakaway Couplings The manufacturer's recommendation shall be used.

b. Anchor Bolts without Breakaway Couplings the nut shall be tightened to snug tight condition by utilizing the full effort of a worker using a standard spud wrench or comparable tool. After all nuts have been brought to a snug tight condition, each nut shall be tightened an additional 1/3 turn using an impact wrench, torque wrench or large crescent wrench.

A minimum of 2 bolt threads shall project beyond the outside face of the nut.

Nuts for bolts other than anchor bolts shall be tightened as outlined under b. above, for anchor bolts.

The bottom of all transformer bases shall be coated with a bitumen-mastic, epoxy paint.

When foundations and anchor bolts for Light Standards have been installed by others, the Contractor shall verify the anchor bolt dimensions at each location so that bases will be furnished with the proper bolt holes.

Wires in the shaft shall be supported with a Kellum-type, braided, strain-relief grip attached to a "J" hook mounted inside the shaft near the top.

Wood Ornamental Light Standards shall be installed as shown on the plans.

634.051 Removing Light Standards Before removing Light Standards, the luminaires shall be removed from the Light Standards and disposed of as noted on the plans.

Care shall be exercised in removing and transporting the Light Standards. The Contractor will be required to replace, at their expense, all equipment damaged or destroyed by their operations.

634.052 Portable Power Unit for Lowering Luminaires The number of portable electric power units with remote control required for operation of the high mast luminaire lowering system, will be 1 for every 10 high mast poles, or as shown on the plans.

634.06 Luminaires Luminaires shall not be installed until the lamp socket position has been inspected and approved for conformance with the manufacturer's recommended position for the specified distribution. All luminaires shall be adjusted to produce the maximum illumination on the roadway surface and shall be full IES cutoff.

The connections between the luminaires and connector kits shall be made with single conductor, number 12 wires AWG copper stranded THHN, minimum size. A 14 inch long Teflon sleeve shall be placed over each end of each conductor in the luminaire.

Installation of a connector kit, fused or non-fused, shall be in accordance with the manufacturer's instructions to provide watertight connections.

634.061 Under-Bridge Lighting Under-bridge lighting shall be installed in accordance with the plans and specifications, or as directed.

Circuits shall be fused in fuse boxes with 5-ampere cartridge-type, midget fuses, $\frac{3}{8}$ inch diameter and 1½ inches long, unless otherwise indicated on the plans. Wiring connections in the under-bridge lighting units shall be made with 300°F wire.

All under bridge lighting, luminaires shall be installed and adjusted for maximum illumination of the roadway surface. The beam angle shall be adjusted as indicated on the plans.

In vehicular undercrossings, underpass lights shall be placed in operation as soon as practicable after falsework has been removed from the structure. Lighting for pedestrian structures shall be placed in operation before opening the structure to pedestrian traffic.

634.08 Service The Contractor shall install metal conduit riser with entrance cap, entrance switch, multiple control relay, and other equipment as shown on the plans.

The lighting system will be supplied with electrical power by the local power company. The type of service will be single phase, three wire, 240/480 volt or the voltage indicated on the plans, 60 hertz, alternating current. The meter trim will include a bypass handle to allow the power company to change the meter without disconnecting the power. An external, standalone breaker capable of shutting off the lighting control cabinet or signals will be provided to disconnect power to the control cabinet. No power shall be routed in or out of the control cabinet before this breaker. The power company will make all connections of the roadway lighting system cables at the power company's service pole. The Contractor shall notify the power company at least two weeks in advance of the time they intend to start construction at each of the sites and shall make all necessary arrangements with the power company for the required installation.

Roadway lighting cabinets shall be installed on stub poles with doors accessible from the roadway. All connections to equipment and terminals shall be neat and orderly conforming to the requirements specified.

Details for the fabrication and installation of service poles with cabinets and other equipment are shown on the plans.

Transformer enclosures used to protect overhead type transformers mounted on concrete pads shall be installed as shown on the plans. Transformers will be furnished by the power company.

All meter mounting devices shall be installed so that the meters will be upright (plumb). They shall be installed with the top of the meter not less than 48 inches nor more than 60 inches from the floor to the final grade. Exceptions to this height requirement will be made where special permission has been given to install group or modular metering, overall metering enclosures, or pole-mounted meters. Level grade shall be maintained for a minimum of 3 feet in front of the meter enclosure to provide a safe working space. In order to meet this requirement on uneven terrain, as an option, the Contractor may install a pressure-treated wood platform.

For any non-residential (industrial or commercial) self-contained meter socket the by-pass requirements are single phase, 100 or 150 amp, single handle lever operated.

The Contractor shall meet all requirements and regulations of Utility Companies when installing equipment on their poles and for the service connection. It is the responsibility of the Contractor to contact the appropriate Utility to determine their specific requirements.

634.081 Bonding and Grounding All metal conduit ends, Light Standards, luminaires, control cabinets, and exposed noncurrent carrying metal parts of fixed equipment shall be connected to the grounding conductor. All grounding and bonding shall conform to the current provisions of the NEC.

634.09 Testing Before acceptance of the work the Contractor shall cause the following tests to be made on all lighting circuits, by a licensed electrician. The tests do not need to be performed in the presence of the Resident, but the test results shall be recorded on the Highway Lighting Quality Control Check List and submitted to the Resident by the Contractor for acceptance. The form shall be signed by the licensed electrician certifying that the highway lighting meet the requirements of section 634.09.

a. Continuity Each circuit shall be tested for continuity.

b. Ground Each circuit shall be tested for grounds.

c. Resistance The resistance to ground on non-ground conductors shall be at least five megaohm at 60°F measured with a 1,000 volt megger. The ground resistance shall not be more than 25 ohms.

d. Voltage Voltage readings shall be made at each service pole, in the load contractor, with load and without load, and at each fixture with load.

e. Current Current readings shall be made on the load side of each load contractor phase and neutral. Readings shall be made at night with lighting systems in normal operation.

f. Test Data Electrical test data obtained from the above tests shall be furnished in writing.

g. Operational Test The Contractor shall conduct an operational test for the completed installation under normal operating conditions. This operational test shall have a duration of not less than two full days. The Resident shall be the sole authority to judge the adequacy of the length of the testing period in order to assure the satisfactory operation of the entire system or any of its sections. The work will not be accepted until the operational test has been successfully completed.

h. Functional Test With all equipment connected to the wiring system, a functional test shall be performed by the Contractor, in the presence of the Resident, to demonstrate that the system and all parts thereof function as specified. All defective materials or faulty installations shall be corrected by repairs or replacements by the Contractor to the satisfaction of the Resident at no additional cost.

Lighting circuits shall be subjected to such other tests as may be required and it shall be the responsibility of the Contractor to ascertain what tests are required and to perform these tests in the presence of the Resident. All tests shall be performed at the expense of the Contractor. Cost for power to conduct tests shall be paid by the Contractor.

634.091 Acceptance All systems shall be complete and in operation to the satisfaction of the Resident at the time of acceptance of the work.

The Contractor shall be responsible for the proper performance in service, in whole or in part, of the various lighting systems and all other electrical installations furnished and installed under this Contract and shall correct, at their own expense, all deficiencies in the operation which may arise prior to acceptance of the work. The Contractor shall be responsible for the cost of power until the work is accepted.

634.092 Method of Measurement Highway lighting system will be measured by the lump sum.

Light Standards will be measured by the single unit, complete in place and accepted.

The quantity of luminaires for high mast lighting will be measured by each single unit.

634.093 Basis of Payment The accepted quantity of Light Standards will be paid for at the contract unit price each for the number of units of the respective types. Payment shall be full compensation for the Light Standard and breakaway transformer base or breakaway device, bracket arm and all incidentals necessary to complete the work, including design of the Light Standards. Conduits, junction boxes, and foundations will be paid for under Section 626.

Payment for furnishing and installing luminaires for high mast lighting will be made for the accepted quantity at the contract unit price each, which shall include luminaire, ballast, lamp, and incidentals necessary to complete the work, including design of the high mast lighting.

The accepted highway lighting system will be paid for at the contract lump sum price for the complete lighting system shown on the plans, except that luminaires for high mast lighting and Light Standards will be paid for at the contract unit price each.

Lump sum payment for highway lighting system shall be full compensation for furnishing, installing and erecting: ballast, lamps, wiring in underground conduit, pole wiring, and all other wiring (except prewired conduit), transformer enclosures, luminaires (except luminaires for high mast lighting), break-away devices when applicable, all identification tags, and all materials, labor, equipment, tools, miscellaneous hardware and incidentals necessary to complete the work. Payment shall also include removing and resetting light standards, installing breakaway devices on existing poles, disposing of unused light standards, as noted on the plans, and for furnishing portable electric power units.

No separate payment will be made for bonding, grounding and ground rods; these costs shall be included in the contract price for conduit, light standards, service panels, or other items requiring bonding and grounding.

Trenching for direct buried cable will be incidental to highway lighting system and shall include excavating, furnishing and placing screened sand and backfilling.

Payment will be made under:

<u>Pay Item</u>		<u>Pay Unit</u>
634.160	Highway Lighting	Lump Sum
634.164	Luminaires for High Mast Lighting	Each
634.2041	Luminaires	Each
634.206	Light Standard for Post Top Luminaire	Each
634.207	High Mast Light Standard	Each
634.209	Wood Ornamental Light Standard	Each
634.210	Conventional Light Standard	Each

SECTION 639
ENGINEERING FACILITIES

Revise this section by removing this section in its entirety and replace with the following:

639.01 Description This work shall consist of providing, erecting, lighting, equipping and maintaining buildings to be solely used by the Resident and other assigned Department representatives as a field office. Upon completion of the work, the buildings and equipment shall remain the property of the Contractor.

639.02 Materials Materials for buildings shall be of good quality customarily used in standard frame house or office trailer construction.

639.03 General The building of the type called for shall be provided before the start of work, and shall remain until work is completed and accepted, unless earlier removal is authorized. The location shall be approved by the Resident and should be adjacent or virtually adjacent to the Project.

A fire extinguisher shall be provided in each building or office trailer for electrical and chemical fires and effective on all solvents used in the building.

Walls, roof, floor, windows, and doors shall be tightly constructed to the required area.

Furnishings shall be supplied as called for. Doors shall be equipped with locks and all keys shall be in the possession of the Resident. Windows shall be equipped with latches so they may be locked on the inside. Window screens and screen doors shall be supplied when necessary. Adequate desk and desk space shall be provided. If a portable table is supplied, it should be adjustable to accommodate the various heights of employees. A 5-way adjustable office chair shall be provided in the quantities listed.

639.04 Field Offices Field Offices are designated Type A, Type B, or Type C. Buildings, including trailers, may be provided if they substantially equal or exceed the following requirements. Air conditioning, appropriate to the building size, shall be provided in all field offices.

The walls, roof, and floor of the building shall be completely insulated with a minimum insulation value of R-15. Office trailers shall be either new or in very good used condition. The interior walls shall be covered with suitable wall paneling. The entire office trailer shall be for the exclusive use of the Resident. The office trailer shall be winterized and completely enclosed at the bottom, if the trailer will be used in cold weather.

Other types of buildings and facilities may be furnished of equal or better quality.

A public work area will be provided in the field office that shall be designed and constructed so that individuals with disabilities can approach, enter, and exit this area.

At least one accessible route to the field office shall be provided from accessible parking. The accessible route shall comply with the Americans with Disabilities Act Accessibility Guidelines (ADAAG) and this specification.

The minimum clear width of an accessible route shall be 36 inches except at doors. The least possible slope shall be used for an accessible route. An accessible route with a running slope

greater than 1:20 shall be considered a ramp. Maximum ramp slope is 1:12. The maximum rise for any run of a ramp shall be 30 inches and the minimum clear width shall be 36 inches. Nowhere shall the cross slope of an accessible route exceed 1:50. Changes in level up to ¼ inch may be vertical and without edge treatment. Changes in level between ¼ inch and ½ inch shall be beveled with a slope no greater than 1:2. Ramp floor surfaces shall be stable, firm, and slip-resistant.

Ground floor surfaces along accessible routes and in accessible rooms and spaces including floors, walks, ramps, stairs, and curb ramps, shall be stable, firm, and slip-resistant.

The main door to the public work area shall have a minimum clear opening of 32 inches with the door opened 90 degrees, measured between the face of door and the opposite stop. Minimum maneuvering clearances at doors shall be provided. The floor or ground area within the required clearances shall be level and clear.

The handle and other operating devices on accessible doors shall have a shape that is easy to grasp with one hand and does not require tight grasping. Lever-operated mechanisms push type mechanisms, and U-shaped handles are acceptable designs. Hardware required for accessible door passage shall be mounted no higher than 48 inches above finished floor.

A minimum of 3 parking spaces will be supplied for Class B & C Field Offices and 6 for Class A. One wheelchair accessible parking space shall be located on the shortest accessible route of travel from adjacent parking to an accessible entrance.

Level landings shall be provided at bottom and top of each run. The landing shall be at least as wide as the ramp run leading to it with a minimum length of 60 inches.

If a ramp run has a rise greater than 6 inches or a horizontal projection greater than 72 inches, then it shall have handrails on both sides. Handrails shall have the following features:

- 1) Handrails shall be provided along both sides of ramp segments. The inside handrail on switchback ramps shall always be continuous.
- 2) If handrails are not continuous, they shall extend at least 12 inches beyond the top and bottom of the ramp segment and shall be parallel with the floor or ground surface.
- 4) The clear space between the handrail and the wall shall be 1½ inch.
- 5) Gripping surfaces shall be continuous.
- 6) Top of handrail gripping surfaces shall be mounted between 34 and 38 inches above ramp surfaces.
- 6) Ends of handrails shall be either rounded or returned smoothly to floor, wall, or post.
- 7) Handrails shall not rotate within their fittings.

8) The diameter or width of the gripping surfaces of a handrail shall be 1¼ to 1½ inch, or the shape shall provide an equivalent gripping surface.

Firm and sturdy steps shall also be provided with 7 inch maximum riser and 11 inch minimum depth, and at least one handrail extending from the top of the steps to a minimum 12 inches beyond the bottom of the steps.

The Contractor will make reasonable effort(s) to provide wheelchair accessible toilet facilities when "portable" facilities are provided.

The Contractor shall provide wheelchair accessible toilet facilities when flush type facilities, that is, those with running water, are provided; and the Contractor shall provide wheelchair accessible portable facilities, if used, when the contract duration exceeds two continuous construction seasons.

In addition to the facilities previously specified in this subsection, each field office shall meet the following minimum requirements:

<u>Description</u>	<u>Quantity</u>		
	<u>Type A</u>	<u>Type B</u>	<u>Type C</u>
Floor Area (Outside Dimension) - ft ²	312	220	125
Inside Wall Height – feet	7	7	7
Window Area - ft ²	55	35	35
Drafting Table Surface Area - ft ²	15	15	15
Drafting Stools - each	2	1	1
Office Desks - each	2	1	1
Ergonomic Swivel Chairs -ea (5-way adjustable)	3	2	2
Folding Chairs - each	3	2	2
Lighting Units - each	4	2	2
Electric Wall Outlets - each	6	4	3
Power Strip Surge Protectors - each	3	2	1
Wall Closets - each	1	1	1
Plan Rack for minimum of 6 sets of plans	1	1	0
Toilet Facility	1	1	1
Wastebaskets - each	2	2	1

All windows shall be provided with shades or blinds.

The toilet facility shall be for the exclusive use of State personnel. If requested, the Contractor will supply a lock to ensure exclusive use.

The Resident will have the option to reject any furniture or supplies provided to the field office based on general condition.

One hundred ten volt, 60 cycle, continuous electric service shall be supplied for lighting and 15 amp duplex wall outlets. Lighting shall consist of florescent light units with rapid start bulbs

or LED shop style lights located over the work areas for a minimum of 50 foot candles overall. At least one external light source will be provided.

Drafting surfaces shall be 40 inches above the floor and have shelves beneath. Shelves for plans and rolls shall also be furnished overhead. Drafting stools shall be approximately 28 inches high.

Desks shall be single or double pedestal standard office type, and shall be in addition to “built-in” type desks in the office trailer.

Field offices shall be furnished with one four-drawer letter size metal filing cabinet.

Wall closets shall be 21 inches wide, 15 inches deep, and at least 4 feet high.

Each office shall be furnished with a broom, dustpan, sweeping compound, trash bags, and with cleaning material for cleaning glass. If the field office is carpeted, then a vacuum cleaner will be provided. The contractor will be responsible for disposing of trash from the field office.

The Contractor shall provide a fully functional wireless desktop copier/scanner/printer, capable of copying field books, for the Resident’s use during the project. All maintenance and supplies, except paper, shall be the responsibility of the Contractor.

The Contractor shall provide bottled water and a microwave for the duration of the project. All maintenance and supplies shall be the responsibility of the Contractor. Alternate source of water, such as a water cooler, may be provided as approved by resident.

The Contractor shall provide a 4 cubic-foot refrigerator in the field office for the duration of the project.

Each office shall be furnished with a 10-person general-purpose first aid kit. The first aid kit shall be periodically inspected and refilled as necessary.

639.08 Heat Heat appropriate to the building size shall be supplied by the Contractor to maintain an acceptable room temperature during occupancy.

639.091 Broadband Connection The contractor will supply one computer broadband connection, modem lease and router. The router shall have wireless access and be 802.11n or newer capable. The type of connection supplied will be contingent upon the availability of services (i.e. DSL or Cable Broadband). It shall be the contractor’s option to provide dynamic or static IP addresses through the service. The selected service will have a minimum download connection of 5.0 Mbps and 1.0 Mbps upload. The contractor shall be responsible for the installation charges and all reinstallation charges following suspended periods. Monthly service and maintenance charges shall be billed by the Internet Service Provider (ISP) directly to the contractor.

639.10 Method of Measurement Field office will be measured by the unit or lump sum for each building provided, equipped and maintained satisfactorily.

639.11 Basis of Payment The accepted quantity of field office will be paid for at the contract unit price each or lump sum which payment shall be full compensation for furnishing until contract completion, erecting, equipping, maintaining, furnishing electricity, heating, installing and maintaining toilet facilities and if necessary removing the buildings or office trailers.

Payment for these items will be made in 3 parts; the first payment of ½ to be made after the Contractor has supplied the building or office trailer and it has been approved. The remaining payments shall be made at intervals as follows:

A second payment of ¼ shall be made when one-half of the anticipated work has been completed.

The final payment of the remaining ¼ shall be made upon completion of the work.

Payment will be made under:

<u>Pay Item</u>	<u>Pay Unit</u>
639.18 Field Office, Type A	Each
639.19 Field Office, Type B	Each
639.20 Field Office, Type C	Each

SECTION 643 **TRAFFIC SIGNALS**

643.01 Description Revise this Section by removing in its entirety and replacing it with:

643.01 Description This work shall consist of furnishing and installing all equipment necessary for the erection and operation of a traffic signal, including traffic signal structures, flashing beacon, temporary traffic signal or modification of a traffic signal, all in reasonably close conformity with the plans.

643.02 General All equipment shall be new unless otherwise specified. Requests for substitution of any specified material shall be submitted in writing with all documentation (specifications, mill certifications, etc.) in order to enable the Department to evaluate the proposal. Substitutes for specified material may be accepted upon approval by the Fabrication Engineer. Functionally, any substitute shall give equal or better service than the specified material. Existing signal equipment to be used shall be cleaned, repainted, and reconditioned as noted on the plans. All equipment, installation of equipment and other incidental work shall conform to the latest applicable provisions of: NEC, MUTCD, NESC,

NEMA, and the ITE Standards for traffic control equipment. All work shall be done to the satisfaction of the Resident. The meaning of specific terms shall be as defined in MUTCD, NESC, and the ITE Standards for traffic control equipment.

643.021 Materials Material shall meet the requirements specified in the following Sections of Division 700 - Materials:

Steel Conduit	715.02
Non-metallic Conduit	715.03
Prewired Conduit	715.04
Metallic Junction and Fuse Box	715.05
Secondary Wiring	715.07
Vehicular Signal Indications	718.01
Pedestrian Signal Indications	718.02
Signal Mounting	718.03
Vehicular Loop Detectors	718.04
Microwave Detectors	718.05
Pedestrian Detectors	718.06
Controllers	718.07
Controller Cabinet	718.08
Flasher	718.09
Program Selection	718.10
Contacts and Relays	718.11
Conductors	718.12
Aluminum Supports	720.01
Aluminum Mast Arm and Bracket Arm	720.02
Steel Supports	720.03
Steel Mast Arm and Bracket Arm	720.04
Anchor Bolts	720.07
Wood Utility Pole	720.10

643.022 Paint Aluminum paint shall conform to AASHTO M69, Type II. Green or yellow enamel paint, as indicated on the plans, shall meet or exceed the latest Federal Specification TT-E-489. The color shall match Federal Color Standard Number 14062.

643.023 Traffic Signal Structures The design, materials and fabrication of Traffic Signal Structures shall meet the requirements of the current edition of AASHTO “LRFD Specifications for Structural Supports for Highway Signs, Luminaires, and Traffic Signals” and interims thereto, as noted below except as otherwise indicated within these specifications or on the plans.

All poles and mast arms shall be designed using the following criteria:

- Basic wind speeds based on a 700-year mean recurrence interval
- K_z as specified in Table C3.8.4-1 (Height and Exposure Factors)
- K_d as specified in Table 3.8.5-1 (Directionality Factors)

- **G as 1.14, minimum (Gust Factor)**
- **C_d as specified in Table 3.8.7-1 (Wind Drag Coefficients)**
- **Deflection requirements as specified in Section 10.4**

Traffic signal support structures shall be classified as Fatigue Category III if they are located on roads with a speed limit of 35 mph or less, Fatigue Category II if they are located on roads with a speed limit of greater than 35 mph, and Fatigue Category I if noted on the Contract Plans. Fatigue Importance Factors shall be as specified in Table 11.6-1 (Fatigue Importance Factors).

All Traffic Signal Structures with mast or bracket arms shall be equipped with an approved damping or energy-absorbing device.

After execution of the contract and before any shop work is commenced, the Contractor shall submit for approval the manufacturer's drawings, including design computations and fatigue computations, of all Traffic Signal Structures proposed to be furnished and erected under this Contract. The drawings shall be of sufficient detail to indicate material and dimensional conformance with these specifications and the plans. Each drawing shall contain a reference to the design criteria and a certification that the design criteria have been met for the Traffic Signal Structures, including poles, mast arms and associated hardware and fittings, as submitted. The certification shall be signed by a Professional Engineer licensed in accordance with State of Maine regulations under their official seal.

It is the intent of these specifications that the Contractor shall be fully responsible for the adequacy of the sizes, wall thicknesses, materials and connections of the Traffic Signal Structures, including poles, mast arms and associated hardware and fittings. Approval of the drawings by the Fabrication Engineer will signify only approval of the materials, mounting height(s) and mast arm length(s). Approval of deviations from the plans and/or specifications shall be requested in writing and approved by the Fabrication Engineer before being incorporated in the manufacturer's drawings.

The Contractor shall furnish and install all electrical fittings, pipe, switches, fuses, and such other material necessary to install the equipment properly and securely. All equipment shall conform to the applicable code and be of first-class workmanship. All electrical fittings shall be complete with weatherproof gaskets.

A Certificate of Compliance shall be provided for all applicable materials noted in Section 634.021 – Materials, in accordance with the requirements of the General Statement of Division 700 Materials. Shop certification in accordance with Section 504.04 is required.

643.024 Miscellaneous Materials Span wire shall be minimum $5/16$ inch diameter, minimum, 7 strand, extra-high strength, galvanized steel wire. Anchors shall be power installed and sized according to strain and soil conditions. All hardware, such as strand vise feed-thru dead ends, preforming guy grip dead ends and angle thimble-eye bolts, shall be standard pole line hardware.

Guying of poles shall meet the requirements of Grade "B" Construction as defined in the NESC. Guys shall be installed in line with the direction of pull. Anchors shall be power installed so that the centerline of the anchor rod will be within 10° of the line of the guy wire. The holding capacity of the anchor shall be 1.25 times the calculated load on the guy wire. Guy wires shall be utility grade and the maximum working stress shall not exceed half of the maximum ultimate tensile strength of utility grade guy strand. Where bedrock is encountered, rock anchors shall be used.

Pipe standoffs for sidewalk anchors shall be galvanized steel pipe sized according to the offset distance from anchor to pole and shall be fitted with standard guying hardware.

Messenger wire shall be ¼ inch diameter, 7 strand, extra-high strength, galvanized steel wire, unless otherwise specified.

LED lamps shall have a regulated power supply designed to electrically protect the diodes. The lamp shall be watertight and sealed to eliminate contaminants. The lamps shall be capable of operating at ambient air temperatures of -40°F to 140°F.

Lamp life shall be a minimum of 100,000 hours of continuous operation. They shall be manufactured using the Allen Gap Technology. Power consumption for 12 inch indications including power supply shall not exceed 20w.

643.03 General Installation details will be shown on the plans and/or specifications. The location shown for all equipment and vehicle detectors is approximate; final locations will be determined in the field.

During installation, all heads installed but not operating shall be covered or otherwise concealed from view.

The requirements of certain Sections of this specification may be waived for temporary traffic signals and traffic signal modifications, if so noted on the plans.

643.04 Poles Wood poles shall be placed in the ground to a depth of 20% of their overall length, with a maximum deviation from the vertical of ¼ inch in 5 feet.

After each wood pole has been set in the ground and plumbed, the space around the pole shall be backfilled with selected earth or sand, free of rocks and other deleterious material, placed in layers approximately 4 inches thick. Each layer shall be moistened and thoroughly compacted.

Traffic Signal Structures shall be erected in a vertical position, with a maximum deviation from the vertical of ¼ inch in 5 feet using the leveling nuts provided with the anchor bolts. Once the poles have been plumbed, the top nuts shall be tightened by bringing the nut to a snug tight condition using the full effort of a worker using a spud wrench or compatible tool. After all nuts have been brought to a snug, tight condition, each nut shall be tightened an

additional one-third turn, using an impact wrench, torque wrench or large crescent wrench. A minimum of two full threads shall project beyond the outside face of the nut. Nuts and bolts, other than anchor bolts, shall also be tightened by the above procedure.

When foundations and anchor bolts have been installed by others, the Contractor shall verify the anchor bolt dimensions at each location so that bases will be furnished with properly located and sized bolt holes.

Wires in poles shall be supported with a Kellum-type, braided, strain-relief grip attached to a "J" hook mounted inside the pole near the top.

643.041 Foundations Foundations for Traffic Signal Structures shall meet the requirements of Section 626 – Foundations, Conduit, and Junction Boxes for Highway Lighting, Traffic Signals, and Highway Lighting.

643.05 Loop Detector and Loop Detector Wire Installation The detector unit shall be located in the controller. No more than four loops shall be connected to a single detector amplifier.

Detectors shall be installed according to the manufacturer's recommendation, subject to approval. Each detector shall be supplied complete with comprehensive installation instructions. The pavement slot for wire shall be 2 to 3 inches below the finished surface and not closer than 18 inches from the edge of pavement or the curb. The right-angle corners of the pavement slot shall be chamfered to eliminate sharp bends in the loop wires.

Loop detector wire shall be number 14 or number 12 AWG copper conductors drawn through vinyl plastic tubing approximately ¼ inch in diameter. All pulse loop "approach" wiring shall be insulated red and shall be permanently marked "A", "B", "C", or "D", according to the "approach" guidelines in the controller cabinet. All pulse loop "presence" wiring shall be insulated black and shall be permanently marked according to the "presence" guidelines in the controller cabinet. All loop lead-ins shall be of the same conductor with no splicing. The lead-in from the amplifier to the beginning of the loop shall be shielded pairs, as shown on the plans.

All debris and moisture shall be removed from the loop pavement slot before installation of loop wires. The pavement slot shall be filled to the road surface with an approved sealing compound to form a waterproof bond with the pavement after installing the wire loop.

Detector conductors shall not be housed in the same jacket as the signal conductors.

643.06 Microwave Detector Installation The microwave detector shall be installed in accordance with the manufacturer's recommendations. A four-conductor wire shall be installed from the microwave unit to the controller. All angles and adjustment of patterns shall be the responsibility of the Contractor. The detectors shall operate in either pulse or presence mode.

643.07 Span Wire, Messenger Wire, and Guy Wire All span wire, messenger wire, and guy wire installations shall be in conformance with the requirements of the Utility Companies, when installed on Utility Facilities.

All span wire hanging traffic signals permanent or temporary will have a bottom tether wire to prevent the signal from excessive swinging

All span wires, messenger wires, guy wires, terminal boxes, controller cabinets, or any other metallic surface that might be contacted by people, shall be bonded to ground.

All sidewalk guy wires and slant guy wires installed in a sidewalk area shall be equipped with full-round or half-round guy guards.

643.08 Conduit All conductors under roadways from the controller to the mast arm poles shall be 3 inch schedule 80 PVC.

643.09 Service Connection The Contractor shall furnish and install the necessary electrical service as directed by the Utility Company. The Contractor shall make all arrangements for the service connection and be responsible for all charges incurred thereby.

Under no condition shall any equipment, except that shown on the plans, be installed on any Utility Facilities.

Traffic signal services shall have an automatic transfer switch such as a GENERLINK model MA23/24 – S installed, this will be required on traffic signals only not beacons or dynamic signs.

Whenever a service connection is to be made, the Contractor shall contact the Utility Company involved and inform them of the location, pole number, and time proposed for the service connection.

The traffic cabinet shall be marked with:

An appropriate arc flash plaque or decal with the following information

Flash hazard boundary

Cal/cm² hazard at 18 inches

PPE level

Shock hazard when cover is off

Limited approach boundary

Restricted approach boundary

The prohibited approach boundary

This shall be located on the outside of the equipment and shall be visible, weatherproof, and fade resistant, and not easily removed.

The Contractor shall be responsible for all outstanding bills for preliminary work done by the Utility Company during the installation of the traffic signal system, to facilitate the service connection.

A service ground rod shall be installed if the service meter trim is not grounded.

The Contractor shall be responsible for grounding the system to 5 OHMS or less. The grounding shall be performed using a ground meter with reference grounds. All testing will be done in the presence of the Resident.

All meter mounting devices shall be installed so that the meters will be upright (plumb). They shall be installed with the top of the meter not less than 48 inches nor more than 60 inches from the floor to the final grade. Exceptions to this height requirement will be made where special permission has been given to install group or modular metering, overall metering enclosures, or pole-mounted meters. Level grade shall be maintained for a minimum of 3 feet in front of the meter enclosure to provide a safe working space. In order to meet this requirement on uneven terrain, as an option, the Contractor may install a pressure-treated wood platform.

For any non-residential (industrial or commercial) self-contained meter socket the by-pass requirements are single phase, 100 or 150 amp, single handle lever operated.

The Contractor shall meet all requirements and regulations of Utility Companies when installing equipment on their poles and for the service connection. It is the responsibility of the Contractor to contact the appropriate Utility to determine their specific requirements.

643.10 Wiring The Contractor shall furnish and install sufficient cable and wire to operate the system properly as shown on the plans and as directed.

The following color code shall be used where possible:

Red Wire	Red, artery
Orange Wire	Yellow, artery
Green Wire	Red, side street
Orange with Tracer	Yellow, side street
Green with Tracer	Green, side street
White and white with tracer	Common for all signals and bond
Blue	All steady burning arrows
Blue with Tracer	Intermittent arrows
Remaining	Detectors and pedestrian signals

The white wire and white wire with tracer shall be used for all common connections and it shall be continuously connected to ground at the controller.

There shall be no wire splices. Connections shall be made on a terminal board inside a watertight galvanized steel or aluminum junction box or in an aerial terminal enclosure with protective cover rated for 600 volts.

Spade type copper terminal ends shall be used to attach all conductors to terminals. All exposed metal parts, including service conduit and the controller cabinet shall be bonded and grounded.

Not more than 3 conductors shall be brought to any one terminal. Terminals shall be mounted to face the cabinet door.

The number and size of conductors required in each cable will be indicated on the plans.

643.11 Vertical Clearance Unless otherwise specified on the plans and/or specifications, vertical clearances for vehicular and pedestrian heads shall be in conformity with the MUTCD. All clearances shall be uniform among each type of head or mounting scheme. Clearance for span wire mounted flashing beacon heads shall be a minimum of 17 feet and a maximum of 18 feet.

643.12 Painting Unless otherwise indicated, all exterior parts of the following equipment shall be delivered to the project finished with green or yellow enamel:

Vehicular Signal Heads
Pedestrian Signal Heads
Pedestrian Push Button Detectors

The outside of the steel controller cabinet shall be painted with aluminum paint.

The Contractor shall apply one coat of green enamel to all existing equipment designated on the plans to be painted. The Contractor shall touch up all scratches on exposed surfaces of new equipment with matching enamel after the equipment has been installed.

All exposed signal parts to be painted shall be cleaned and shall be dry when the paint is applied. No painting shall be done in damp weather nor when the air temperature is below 40°F, unless otherwise permitted.

The Contractor shall identify recently painted equipment with "Wet Paint" signs, and shall be responsible for all claims for damages resulting from contact with wet paint surfaces.

643.13 Power Factor In the event that the equipment is of such design that the power factor is reduced below the requirement of the Utility Company, the Contractor shall furnish and install, without further charge, all equipment necessary to restore the power factor to a satisfactory percentage. Such equipment shall be accessible and shall not be mounted on the Utility Facilities.

643.14 Field Tests Before acceptance of the work, the Contractor shall conduct the following tests on all traffic signal equipment and circuits, by a licensed electrician. The tests do not need to be performed in the presence of the Resident, but the test results shall be recorded on the Traffic Signal Quality Control Check List and submitted to the Resident by the Contractor for acceptance. The form shall be signed by the licensed electrician certifying that the signal equipment and circuits meet the requirements of section 634.14.

a. Continuity Each circuit shall be tested for continuity.

b. Ground Each circuit shall be tested for grounds.

c. Megger Megger tests at 500 volts DC shall be made on each circuit between the circuit and a ground. The insulation resistance shall not be less than 10 megaohms on all circuits, except for inductive loop detector circuits, which shall have an insulation resistance value of not less than 100 megaohms.

d. Loop Inductance A loop test meter shall be used to determine that the inductance of the installed loop and lead-in are within the tuning range recommended by the loop detector manufacturer.

e. Functional A functional test shall be made in which it is demonstrated that each part of the system functions as specified.

The functional test for each new or modified traffic signal and flashing beacon shall consist of not less than 10 days of continuous satisfactory operation. If unsatisfactory performance of the system develops, the condition shall be corrected and the test shall be repeated until the 10 days of continuous satisfactory operation is obtained.

The initial operation shall be made between 9:00 A.M. and 2:00 P.M. unless specified otherwise. Before initial operation, all equipment shown on the plans shall be installed and operable.

Initial operation of new or modified traffic signal systems shall be made only after all traffic signal circuits have been thoroughly tested as specified above.

During the test period all costs except electrical energy shall be the Contractor's responsibility.

Functional tests shall start on any working day except Monday, Friday, Saturday, Sunday or the day preceding a legal holiday.

Shutdown caused by a power interruption shall not constitute discontinuity of the functional test, however, the test shall continue after power is restored.

643.15 Timing The controller shall be timed as noted on the plans. The Contractor shall notify the Resident, at least 1 week in advance, of their intention to initially operate the signals.

At the time of initial operation of the new signals, the Contractor shall provide police protection from the local police department at the Contractor's expense until the Contractor demonstrates to the Resident that the signal operates in conformance with this specification.

643.16 Final Cleaning Up After all work has been completed, the Contractor shall remove all barriers, "Wet Paint" signs, equipment and all debris which has accumulated during the work.

Unless otherwise specified in the plans, the Contractor shall remove and deliver all unused signal equipment and wiring to the State of Maine, Department of Transportation, as directed by the Resident. The Contractor shall notify the State Traffic Engineer (207-624-3620) as to time and date of such delivery. (Deliveries will be accepted Monday through Friday between the hours of 7:00 A.M. and 4:00 P.M. only.) Notification shall precede delivery by a minimum of 24 hours.

643.17 Documents The Contractor shall furnish two operation and maintenance manuals for all controller units, auxiliary equipment, vehicle detector sensor units, control units, and amplifiers. Documents shall be delivered with the controller at the time of testing. Each manual must include, but need not be limited to the following:

- a. An explanation of the theory of operation, including a functional description and a detailed circuit description.
- b. A schematic diagram of each unit. A cabinet wiring diagram including all field wiring and pin locations and designations for all plug type connectors. If any circuit changes are made in the field, the changes shall be noted on the schematic diagrams.
- c. A trouble shooting and preventive maintenance procedure including both field and bench trouble shooting analysis.
- d. A parts list including a pictorial diagram showing the location and identification of each component on the chassis or circuit board.
- e. A drawing of the controller cabinet interior showing the location of all shelves, terminal blocks, relays, timers, loop amplifiers.

In addition, manufacturer's warranties and guarantees for materials shall be delivered to the Resident before acceptance of the project.

643.18 Method of Measurement Traffic signals, traffic signal modifications, interconnect wire, video detection system, traffic signal control system, and flashing beacons will each be measured for payment by the lump sum in place. Temporary traffic signals will be measured for payment by the lump sum, satisfactorily installed, operated, and removed.

Pedestal poles, strain poles, combination poles, and mast arm poles with mast arms will be measured by each unit.

Each loop detector installed, connected to appropriate phases in the controller cabinet, complete and operational will be measured by the unit.

Excavation in solid ledge rock for replacement of wood poles will be measured by the cubic yard. The depth of measurement will be to the bottom of the pole, and the diameter of measurement will be the pole diameter plus 30 inches.

643.19 Basis of Payment Traffic signal modifications, traffic signals, interconnect wire and flashing beacons will be paid for at the contract lump sum price, which payment will be full compensation for furnishing and installing all materials, both new and reused, including, but not limited to wood poles, span wire, tether wires, backplates, visors, guys, controllers, vehicular heads, pedestrian heads, flashing beacons, wiring, cable, pole risers, LED lamps, and all appurtenances and incidentals, including design of the Traffic Signal Structures, required for a complete functioning installation and for furnishing all tools and labor necessary for completing the installation. Conduits, junction boxes, and foundations will be paid for under Section 626.

Pedestal poles, strain poles, combination poles and mast arm poles with mast arms will be paid for at the contract unit price each which payment shall be full compensation for furnishing and installing all materials, tools and labor necessary to erect the poles.

Payment for temporary traffic signals shall include compensation for the removal of the system upon completion of the work. All materials used for temporary traffic signals will remain the property of the Contractor. Operating the controller by hand will be paid for under Section 629.

Payment will be made for each Loop Detector at contract price, which will be full compensation for materials, labor, and equipment for each loop installed and fully operational.

Traffic signal control system will be paid for at the contract lump sum price, which payment will be full compensation for furnishing and installing all materials, including, but not limited to local intersection traffic signal controller, controller cabinets, on-street master controller, supervisory PC software, and all appurtenances and incidentals required for a complete functioning installation.

Video detection system will be paid for at the contract lump sum price, which payment will be full compensation for furnishing and installing all materials, including, but not limited to video processing unit, video cameras, supervisory PC software, and all appurtenances and incidentals required for a complete functioning installation.

Payment for excavation of solid bedrock for the placement of wood poles will be made under Item 206.07.

Payment will be made under:

<u>Pay Item</u>		<u>Pay Unit</u>
643.60	Flashing Beacon at:	Lump Sum
643.71	Traffic Signal Modification:	Lump Sum
643.72	Temporary Traffic Signal:	Lump Sum
643.80	Traffic Signals at: __	Lump Sum
643.81	Traffic Signal Control System	Lump Sum
643.83	Video Detection System	Lump Sum
643.86	Traffic Signal Loop Detector	Each
643.90	Interconnect Wire Between:	Lump Sum
643.91	Mast Arm Pole	Each
643.92	Pedestal Pole	Each
643.93	Strain Pole	Each
643.94	Dual Purpose Pole	Each

SECTION 645 HIGHWAY SIGNING

Revise this section by removing this section in its entirety and replace with the following:

645.01 Description This work shall consist of designing, furnishing and installing new signs, sign supports, delineators, Polyvinylchloride (PVC) Pipe and breakaway devices and removing, relocating and/or modifying existing signs and sign supports, in accordance with these specifications and in reasonably close conformity with the Contract Plans.

645.02 General All equipment shall be new unless otherwise specified. Requests for substitution of any specified material shall be submitted in writing with all documentation (specifications, mill certifications, etc.) in order to enable the Department to evaluate the proposal. Substitutes for specified material may be accepted, upon approval of the Fabrication Engineer. Substitutes shall give equal or better service than the specified material. Where an existing system is to be modified, the existing material shall be removed, upgraded, or disposed of as directed by the contract documents.

645.021 Materials Materials shall meet the requirements specified in the following Sections of Division 700 - Materials:

Polyvinylchloride (PVC) Pipe	706.08
Reflective Sheeting	719.01
Demountable High Intensity Reflectorized Letters, Numerals, Symbols and Borders	719.02
Aluminum Extrusions	719.03

Aluminum Sheets	719.04
Plywood	719.05
Demountable Reflectorized Delineators	719.06
Assembly Hardware	719.07
Aluminum Supports	720.01
Steel Supports	720.03
Steel H-beam Poles	720.06
Anchor Bolts	720.07
U-Channel Posts	720.08
Wood Sign Posts	720.12

Paint for the edge and back of plywood and field coat paint for wood sign posts shall be an exterior grade dark green enamel conforming to Federal Specifications TT-P-71b.

Materials shall meet the gradation requirements only of the following:

Aggregate for Untreated Surface Course and Leveling Course	703.10
Underdrain Backfill Material	703.22

645.022 Sign Layout Drawings The Contractor shall submit 3 sets of sign-face, layout-detail, and scale drawings. Fabrication of the signs shall not begin until the Contractor has received approval of these drawings. The drawings shall contain complete detailed information and dimensions. One set of drawings will be returned to the Contractor, who will submit corrected drawings, if required. The drawings shall be detailed using the same units used on the Contract Plans.

645.023 Sign Support Structures The design, materials and fabrication of Sign Support Structures shall meet the requirements of the current edition of AASHTO “LRFD Specifications for Structural Supports for Highway Signs, Luminaires, and Traffic Signals” and interims thereto, as noted below except as otherwise indicated within these specifications or on the Contract Plans.

Beam-mounted roadside sign supports and associated signs and hardware shall be designed using the following criteria:

- Basic wind speeds based on a 300-year mean recurrence interval
- K_z as specified in Table C3.8.4-1 (Height and Exposure Factors)
- K_d as specified in Table 3.8.5-1 (Directionality Factors)
- G as 1.14, minimum (Gust Factor)
- C_d as specified in Table 3.8.7-1 (Wind Drag Coefficients)

Bridge-mounted, bridge-type, cantilever, and butterfly-type sign supports and associated signs and hardware and all sign support structures supporting variable message signs shall be designed using the following criteria:

- Basic wind speeds based on a 1700-year mean recurrence interval

- K_z as specified in Table C3.8.4-1 (Height and Exposure Factors)
- K_d as specified in Table 3.8.5-1 (Directionality Factors)
- G as 1.14, minimum (Gust Factor)
- C_d as specified in Table 3.8.7-1 (Wind Drag Coefficients)
- Deflection requirements as specified in Section 10.4

Cantilever and butterfly-type sign supports and all structures supporting variable message signs shall be classified as Fatigue Category I. Bridge-type sign supports shall be classified as Fatigue Category II. Fatigue Importance Factors shall be as specified in Table 11.6-1 (Fatigue Importance Factors).

For bridge-mounted sign supports (including approaches to bridge structures), the mounting height shall be measured as the distance of the mounted sign(s) center of gravity to one of the following:

For bridges over bodies of water: above the prevailing water level or, in the case of tidal waters, above mean high tide.

For overpass structures: above the lower roadway level.

For approach ramps: above the average adjacent ground level, if said ground level is more than 10 feet below the base of the structure.

All cantilever and butterfly type sign support structures shall be equipped with an approved damping or energy-absorbing device.

For aluminum construction, welding shall conform to the current edition of AWS Structural Welding Code, Aluminum, D1.2 for aluminum construction.

After execution of the contract and before any shop work has commenced, the Contractor shall submit for approval the drawings, and design and fatigue computations if prescribed below, for all Sign Support Structures proposed to be furnished and erected under this contract. The drawings shall be of sufficient detail to indicate material and/or dimensional conformance with these specifications and the Contract Plans and, in the case of bridge, cantilever and butterfly type sign supports, shall be sufficiently detailed to show all significant structural details.

Approval for deviations from the Contract Plans and/or Specifications shall be requested in writing and shall be approved by the Fabrication Engineer before being incorporated in the manufacturer's drawings. Requests for substitution of all specified material shall be submitted in writing, with full documentation (specifications, mill certification, etc.) enabling the Department to evaluate the proposal.

Sign Support Structures and anchor bolts shall meet the requirements specified in Section 720 as well as the current edition of AASHTO "LRFD Specifications for Structural Supports for Highway Signs, Luminaires, and Traffic Signals" and interims thereto.

A Certificate of Compliance shall be provided for all applicable materials noted in Section 645.021 – Materials, in accordance with the requirements of the General Statement of Division 700 - Materials.

a. Beam-Mounted Roadside Signs The beams for beam-mounted roadside signs shall be of the size, material and shape designated in the Contract Documents. The Contractor shall be fully responsible for the adequacy and design of any structural details not shown on the Contract Plans, and each drawing shall contain a reference to the design criteria. A Professional Engineer licensed in accordance with the State of Maine regulations shall sign the certification under their official seal that said design criteria have been met by all parts of the structure designed and/or detailed by the Contractor. Approval of the drawings will signify only approval of the size, material and length of the beam.

b. Bridge-Mounted Sign Supports Bridge-mounted sign supports shall be constructed to the configuration and sizes and of the material shown on the Contract Documents. Approval will be based on the applicable provisions of Section 105.7 - Working Drawings. Fastening sign panels directly to steel or aluminum members shall be as described in Section 719.07, as well as other applicable Sections, Plans and Specifications.

c. Bridge-Type, Cantilever, and Butterfly-Type Sign Supports The Contractor shall be responsible for the design of the Sign Support Structures for bridge-type, cantilever and butterfly-type sign supports in accordance with this specification.

Signs shall be placed on the Sign Support Structure such that the bottom edges are aligned (unless written consent from the Fabrication Engineer is obtained), while accommodating the minimum height requirement - see Section 645.06. The Contractor shall use the Contract Plans in order to determine the approximate horizontal placement of signs. Installation shall be in accordance with Section 645.06 - Installation of Type I Signs. The structure and foundation shall be designed to accommodate an additional theoretical sign load on each structure. This additional theoretical sign load for each sign shown in the contract documents shall be computed by: For single signs increasing the sign widths an additional 25% without changing the horizontal midpoint of the sign; for multiple signs the sign widths shall be increased 25% toward the outside sign edges. The height of all signs shall be increased 25% without changing the bottom edge elevation of the signs.

Bridge-type Sign Support Structures shall be designed using either a tri-chord or four-chord truss structure as the overhead member. Each of the two upright members supporting the bridge-type overhead truss member shall consist of a minimum of two vertical legs. A four chord truss configuration shall be required if the Contract Documents specify placing signs on both sides of the overhead structure (two way traffic beneath structure). Cantilever and butterfly-type structures shall be designed using either a tri-chord or four-chord overhead truss member. The upright member of a cantilever or butterfly-type support structure shall have a maximum horizontal

deflection in accordance with Section 10.4.2.1 of the current edition of the AASHTO “LRFD Specifications for Structural Supports for Highway Signs, Luminaires, and Traffic Signals”, and interims thereto.

The base plates of uprights for all types of Sign Support Structures shall have heavy hex leveling nut with 2 hardened flat washers. The distance between the bottom of the base plates to the top of the foundations shall not exceed twice the diameter of the anchor bolts. Grout, or other materials, shall not be placed between base plates and the top of foundations.

In addition to the required detail drawings, the Contractor shall submit 3 copies of the design and fatigue computations meeting the all applicable requirements of this specification or the Contract Plans for each Sign Support Structure. Erection lifting points shall be clearly depicted on the shop drawing. The computations shall be sufficiently detailed to allow the Engineer to review the computations. Computer printouts will not be accepted unless they meet the above criteria. All plans and design calculations for sign support structures and foundations shall be sealed by a Professional Engineer licensed in accordance with the State of Maine regulations. Approval will be based on the applicable provisions of Section 105.7 - Working Drawings.

Overhead sign panel mounting devices shall be designed accommodating the requirements of appropriate sign panel tilting included in this specification. The design of this assembly shall include fastening sign panels directly to steel or aluminum members as further described in Section 719.07, as well as other applicable Sections, Plans and Specifications.

d. Breakaway Supports for Sign Supports Breakaway supports for sign supports will be required only for those locations indicated on the Contract Plans. Breakaway supports, approved by the Resident, using load-concentrating couplings shall be supplied for use at all locations designated as breakaway. Breakaway Support Certification of both breakaway and structural adequacy shall be provided by the Manufacturer. Design calculations or test data of production samples to support certification shall be provided. Breakaway support components shall provide the same or greater structural strength as the support post or pole utilizing the breakaway device. On multi-pole sign supports designated as breakaway, each pole shall be equipped with breakaway hinges immediately below the lower edge of the sign. Hinges relying on the friction between the hinge and the pole face for transmitting the design moment will not be accepted for use. Breakaway devices are subject to the applicable provisions of Section 721.

645.024 Bridge, Cantilever and Butterfly Support Structure Foundations Foundations for Highway Signing structures shall meet the requirements of Section 626 – Foundations, Conduit, and Junction Boxes for Highway Lighting, Traffic Signals, and Highway Lighting.

645.03 Classification of Signs Sign sizes, color and legend designs shall conform to these specifications, the Contract Plans, and MUTCD requirements. The signs are classified according to the intended use as follows:

- a. Sign Type I guide signs shall consist of high intensity prismatic, reflectorized sheeting or reflectorized, demountable letters, numerals, symbols and border mounted on a high intensity prismatic, reflective sheeting background adhered to a sign panel constructed of extruded aluminum planks.
- b. Sign Type I regulatory, warning, and route marker assembly signs shall consist of high intensity prismatic, reflective sheeting letters, numerals, symbols, and border on a high intensity prismatic, reflective sheeting background adhered to a sign panel constructed of sheet aluminum.
- c. Sign Type II guide signs shall consist of high intensity prismatic, reflective sheeting letters, numerals, symbols and border on a high intensity prismatic, reflective sheeting background attached to a sign panel constructed of plywood.
- d. Sign Type II regulatory, warning and route marker assembly signs shall consist of high intensity prismatic reflective sheeting letters, numerals, symbols and border on a high intensity prismatic reflective sheeting background adhered to a sign panel constructed of sheet aluminum or plywood.

645.04 Fabrication of Type I Guide Signs

a. Panels The panels for this type sign shall be shop-fabricated from aluminum planks to the sizes designated on the approved shop drawings. Cut edges shall be true, smooth, and free from burrs or ragged breaks. Flame cutting will not be permitted. Bolt holes may be drilled to finished size or punched to finished size, provided the diameter of the punched hole is at least twice the thickness of the metal being punched.

Fabrication of extruded aluminum sign planks, including punching or drilling holes and cutting to length, shall be completed before the metal degreasing and the application of the reflective sheeting. The bolts required for fastening the extruded aluminum planks together shall conform to the designs used in standard commercial processes for the type of extruded aluminum panels to be used as approved.

All route shields shall be on an overlay aluminum sheet of 0.080 inch minimum thickness and shall be in full color with reflective background; they shall not have demountable numerals and borders.

b. Reflective Sheeting The high intensity prismatic reflective sheeting shall be applied to the extruded aluminum plank in accordance with the current recommendations of the sheeting Manufacturer.

The reflective sheeting shall cover the complete panel and shall not be trimmed to conform to the border. The reflective sheeting shall overlap into the side recess of the individual planks. There shall be no paint applied to the sign panels. The surface of all completed sign panels shall be flat and free of defects. Extruded aluminum molding shall be placed on the edges of the extruded panels, as shown on the Contract Plans.

c. Text The design of upper and lower case letters, numerals and symbols, and the arrangement and spacing of texts shall be as provided on the Contract Plans and in conformance with the MUTCD and Standard Highway Signs.

Text for Guide Signs shall be composed of demountable letters, numerals, symbols, and borders and shall be high-intensity prismatic, reflective sheeting. The demountable text shall be applied to the panels by use of aluminum pop rivets, in accordance with standard commercial processes, as approved. All demountable letters, numerals, symbols, and borders shall be the same manufacturer's make for the entire project. Cutout high-intensity, reflective sheeting text shall be applied to the sign panel with a pre-coated, adhesive backing.

645.041 Fabrication of Type I Regulatory, Warning and Route Marker Assembly Signs and Type II Sheet Aluminum Regulatory, Warning and Route Marker Assembly Signs

a. Panels Sheet aluminum sign panels shall be shop-fabricated to the size shown on the Contract Plans. The corners shall be rounded to the indicated radius where shown.

Bolt holes may be drilled or punched to finished size provided the diameter of the punched hole is at least twice the thickness of the metal being punched. Cut edges shall be true, smooth, and free from burrs or ragged breaks. Flame cutting will not be permitted. Punching or drilling of holes and cutting to size shall be completed before metal degreasing and the application of reflective sheeting.

b. Reflective Sheeting The high intensity prismatic reflective sheeting shall be applied to the sheet aluminum sign panels in accordance with the current recommendations of the sheeting Manufacturer. The reflective sheeting colors shall conform to the MUTCD Standard Highway Sign colors for each type of sign. Surface of all panels shall be flat and free from defects.

c. Text The text for regulatory, warning, confirmation and route marker assembly signs shall be composed of: High intensity prismatic, reflective sheeting letters, numerals, symbols and borders; or the silver letters may be formed by applying transparent ink to the reflective sheeting background where the silk screen process is used; or other methods to form the text may be used, when approved in advance.

645.042 Fabrication of Type II Guide Signs and Type II Plywood, Regulatory, Warning and Route Marker Assembly Signs

a. Panels Fabrication of all sign panels from high-density, overlaid plywood shall be performed in a uniform manner. All fabrication, including cutting, drilling, and edge routing, shall be completed prior to painting and application of reflective sheeting to the high-density, overlaid plywood. Panels shall be cut to size and shall be plywood. Panels shall be cut to size and shall be free of warping, open checks, open splits, open joints, open cracks, loose knots and other defects resulting from fabrication. Corners shall be left square. The surface of all sign panels shall be flat.

The edge and back of the plywood shall be painted with an exterior grade dark green paint.

b. Blanks Sign blanks shall be cut to shape using a saw blade that does not tear plywood grain. Holes shall be clean-cut and uniform. All cracks, open checks, open splits and other defects occurring on the edge surfaces shall be filled with a synthetic wood filler and sanded smooth prior to sealing and painting. The sign blank edges shall be sealed using an approved sealer/primer. The edges shall then be painted with an exterior grade, dark green paint.

The surface shall not be painted before application of reflective sheeting. Before applying reflective sheeting, dirt or wax shall be removed by one of the following methods:

1. The surface shall be buffed lightly with solvent-soaked steel wool, fine or medium, using organic solvents, such as lacquer thinner, xylol, heptane, benzene or naphtha, and wiped dry with clean cloths.
2. The panel shall be sanded lightly with fine-grade paper, cleaned with solvent, and wiped dry using clean cloths.

c. Reflective Sheeting The High intensity prismatic reflective sheeting shall be applied directly to the cleaned high-density surface in accordance with the recommendations of the reflective sheeting manufacturer.

d. Text The text for regulatory, warning, confirmation and route marker assembly signs shall be composed of cutout, High intensity prismatic reflective sheeting letters, numerals, symbols and borders or the silver letters may be formed by applying transparent ink to the reflective sheeting background where the silk screen process is used. Other methods to form the text may be used when approved in advance.

The design of the letters, numerals, and symbols, the spacing of the text and the size and spacing of the border shall conform to the MUTCD and Standard Highway Signs.

645.06 Installation of Type I Signs The sign locations shown on the Contract Plans are approximate; exact locations will be determined in the field by the Resident. Signs stockpiled before erection shall be stored in a vertical position and completely covered to avoid staining, weathering, and dirt accumulation.

a. Sign Supports Poles for single and multiple support beam-mounted roadside signs shall be erected plumb, using the leveling nuts supplied with the anchor bolts. When signs are supported by more than one pole, all poles shall be carefully aligned to avoid warping of the sign panel.

Bridge-mounted sign supports shall be fabricated and assembled in accordance with the details as shown on the Contract Plans and with Section 504. Additionally, if required to be painted, bridge-mounted sign supports shall be painted in accordance with Section 506.

Bridge-type, butterfly and cantilever-type sign supports and their foundations shall be constructed, assembled and erected, in accordance with the manufacturer's details, as approved. All horizontal supports spanning the roadway shall be level and shall have permanent camber as described in Section 10.5 of the current edition of AASHTO "LRFD Specifications for Structural Supports for Highway Signs, Luminaires, and Traffic Signals", and interims thereto. If, at any time after their erection, bridge-type, butterfly or cantilever-type sign supports are to remain for a period in excess of 72 hours without the sign(s) for which they were designed being in place, suitable vibration damping devices, approved by the Resident, shall be installed until such time as the sign(s) can be erected.

Where aluminum surfaces are in contact with concrete or dissimilar metals, the contacting surface shall be thoroughly coated with an approved aluminum impregnated caulking compound, or the surfaces shall be separated by another approved material. Before signs are attached, aluminum sign supports shall be cleaned of all dirt and discoloration using methods recommended by the manufacturer.

b. Sign Panels Extruded aluminum planks for sign panels shall be bolted together, as indicated on the Contract Plans. Extruded aluminum molding shall be placed on the edges of the extruded panels. Sign panels shall be attached to the posts to provide the vertical and horizontal clearances from the roadway as indicated on the Contract Plans. Sign panels on overhead structures shall provide a minimum vertical clearance of 18 feet to the highest point of the roadway surface under the sign(s). Sign panels on bridge-mounted sign supports shall be installed with the bottom edge of the sign approximately 4 inches above the bottom of the bridge beam.

Sign panels mounted over the roadway shall tilt in the direction of the approaching traffic in such a manner that the angle between the sign face and the roadway grade, at the sign location shall be $85^{\circ} \pm 3^{\circ}$.

Ground-mounted signs located 4 to 30 feet from the edge of shoulder shall form an angle of 93° between the approach roadway and the sign.

Signs located more than 30 feet from the edge of the shoulder shall form an angle between the approach roadway and the sign face equal to $87^{\circ} - 1^{\circ}$ for each additional 10 feet beyond 30 feet.

Unless otherwise shown on the Contract Plans, or designated by the Resident, a minimum lateral clearance of 4 feet shall be provided between the edge of the shoulder and the edge of any sign panel.

The elevation of the bottom edge of guide sign panels shall be 7 feet above the elevation of the edge of the traveled way, at the sign location, or in case of a curb section, 7 feet above the elevation of the outer edge of the roadway, unless authorized otherwise.

Signs located 30 feet or more from the edge of traveled way shall be 5 feet above the elevation of the edge of shoulder.

In the event that a second sign is to be placed under the main sign, the elevation of the bottom edge of the principal sign shall be a minimum of 8 feet above the outer edge of the traveled way, or a minimum of 8 feet above the edge of the traveled way, in curbed sections; the bottom edge of the second sign must be at least 5 feet above the edge of the traveled way.

The elevation of the bottom edge of the regulatory, warning and route marker sign panels shall be 6 feet above the elevation of the edge of the pavement, or edge of roadway in curbed sections, at the sign location. The elevation of the bottom edge of these sign panels above the elevation of the edge of the pavement on all crossing or connecting roadways shall be 5 feet in rural areas or 7 feet in urban areas. Field conditions may require some variation in elevations, as directed.

Each sign shall have at least two fasteners connecting it to the sign poles, except signs of 1 foot or less in height may have one fastener.

645.061 Installation of Type II Signs The exact sign locations will be determined in the field. Signs stockpiled before erection shall be stored in a vertical position and completely covered to avoid staining, weathering, and dirt accumulation.

When a steel pole is to be used, before any shop work is commenced, the Contractor shall submit 3 sets of the manufacturer's drawings of all standards and accessories proposed to be furnished and erected under this contract. The drawings shall be of sufficient detail to indicate material and/or dimensional conformance with these specifications and the contract drawings. Each drawing shall contain a reference to the design criteria and certification that the design criteria have been met for current edition of the AASHTO "LRFD Specifications for Structural Supports for Highway Signs, Luminaires, and Traffic Signals", and interims thereto, for bracket arms and associated hardware, fittings and breakaway devices, as submitted. A Professional Engineer licensed in accordance with the State of Maine regulations shall sign the certification under their official seal. The drawings shall use the same units as found in the Contract Plans. It is the intent of these specifications that the Contractor shall be

fully responsible for the adequacy of the sizes, wall thickness, materials and connections of the standards, bracket arms and associated hardware, fittings and breakaway devices. Approval of the drawings will signify only approval of the material(s), mounting heights(s) and bracket arm length(s).

a. Sign Supports Support posts for Type II signs shall be U-channel posts weighing 2½ pounds per foot for signs of less than 6.24 ft² in area, 4 inch by 4 inch wood posts or two U-channel posts weighing 2½ lb/ft for signs of area 6.24 ft² to 9 ft², 4 inch by 6 inch wood posts for signs of area 9 ft² to 16 ft², and 6 inch by 6 inch wood posts for signs of area over 16 ft². All signs 60 inches wide or wider shall be mounted on two wood posts. Wood posts shall be set to a depth of 4 feet. U-channel posts shall be set to a minimum depth of 30 inches. Leading signs less than 9 ft² on the apex of islands will be installed on U-channel posts. Solar powered sign mounted beacon arrays shall be mounted on galvanized steel poles. Any signs installed on/in an island, shall be installed in a PVC sleeve of the appropriate size for the type of post being installed, as shown in the standard details.

When it is necessary to set sign posts in bedrock, holes shall be excavated to the required depth and size at the locations indicated on the Contact Plans. The excavated material will be satisfactorily disposed of, as directed, and the posts set to the required depth.

When installing pressure-treated sign posts, the cut end of the posts shall not be buried in the ground.

Backfilling around the posts shall be with excavated material unless the excavated material is considered unsatisfactory, in which case the backfill shall be granular material conforming to the requirements of Section 703.19 - Granular Borrow. Backfill shall be thoroughly tamped in layers not exceeding 8 inches in depth.

When directed, the area around the posts shall be loamed and seeded in accordance with the applicable provisions of Section 615 and Section 618.

The Contractor shall be responsible for and shall repair all damage to underground drainage structures, utilities, or lighting conduits encountered during placing the posts.

b. Mounting Type II signs shall be mounted using assembly hardware specified in Section 719.07.

PVC pipe shall be installed in all locations where sign posts are to be placed in paved islands and shall have an inside diameter of 12 inches. For sleeves that are to be utilized for U-channel posts, the PVC pipe shall have a minimum length of 3 feet. For sleeves that are to be utilized for wood posts, the PVC pipe shall have a minimum length of 5 feet.

Installation of the PVC pipe shall occur prior to paving of the island. The pipe shall be placed at a depth so that the top of the pipe shall have no more than a 1 inch reveal from finished surface pavement. Once placed, the pipe shall be backfilled around the outside

diameter in layers that are thoroughly compacted and that do not exceed a depth of 8 inches.

Once installed and backfilled, the pipe shall be completely filled to the top of the pipe with material that meets the gradation requirements of Aggregate for Untreated Surface Course and Leveling Course Type A or Type B or Underdrain Backfill Material.

645.062 Installation of Delineators Posts for delineators shall be erected so that posts and assemblies will be plumb. All posts, which are bent or otherwise damaged, shall be removed and properly replaced. Posts shall be driven 4 feet from the outside edge of shoulder, 4 feet from the face of curb and 4 feet from the normal edge of shoulder in guardrail sections. A suitable driving cap shall be used and after driving, the top of the post shall have substantially the same cross sectional dimensions as the body of the post.

When bedrock is encountered in erecting posts, the depth to be drilled into the rock shall be determined by the Resident.

After the posts are driven, delineators shall be mounted 4 feet above the elevation of the edge of the traveled way. In the event that a delineator is required to be installed on a bridge structure, it shall be installed by use of a bracket as shown on the Contract Plans.

Sign support posts to be installed in the sleeve shall be plumbed and set in the material which shall be compacted or tamped around the post. The posts shall be placed so that there is a 2 foot maximum distance from the bottom of the retro-reflective strip on the sign post to the paved travelway or shoulder surface. For wooden posts only, 4 feet of the post shall be placed in the sleeve. Other sign support post installation requirements shall be followed as per Section 645 of the Standard Specifications.

645.063 Installation of Breakaway Devices Breakaway devices shall be installed at locations indicated on the Contact Plans by an approved method. Each sign and pole shall be carefully demounted for reinstallation at the same or at a new location. Manufacturer's installation information shall be provided on the project.

If required, poles shall be cut in such a manner that no rough edges will remain. No flame cutting will be permitted. Cut edges on steel poles shall be painted in accordance with Section 645.07.

Existing foundations shall be modified for attachment of the breakaway device as shown on the Contract Plans or approved.

Breakaway devices shall be attached to new foundations in accordance with the recommendations of the breakaway device manufacturer and as approved.

645.064 Installation of Sign Mounted Beacon Array Beacons installation shall conform to current MUTCD standards.

Battery and solar assembly shall be of sufficient size to power sign for 7 days without solar charging. Batteries shall be gel cell or absorbed glass mat (AGM) batteries. Solar panel shall be installed facing true south and 60 degrees from vertical.

Connections to service shall be in accordance with section 643.09.

The cabinet should be positioned on the side of the pole farthest from traffic. Only aluminum and steel cabinets will be accepted. All exposed wiring shall be in accordance with section 715.11.

All wiring shall be in accordance with section 718.01-c.

Beacon Array shall meet testing requirements outlined in sections 643.14 a, b, and e.

645.07 Demounting and Reinstalling Existing Signs and Poles Signs and poles designated to be demounted and not designated to be reinstalled, except those designated to be demounted by others, shall be delivered to the Resident.

Existing sign panels, poles, foundations, and sign hardware, damaged because of the Contractor's operations shall be replaced or repaired by the Contractor to the satisfaction of the Resident.

New or relocated regulatory, warning, confirmation or route marker assembly signs shall be installed the same working day as the corresponding existing signs are demounted. All new or relocated guide signs shall be installed within two working days of the time the corresponding existing sign is demounted. Before the Contractor demounts any regulatory or warning sign, they shall erect a similar easel mounted sign at a designated location. The Contractor shall maintain this temporary sign in place until the permanent sign is installed.

Existing signs and poles shall be reinstalled in accordance with the applicable requirements for installing new signs and poles.

Relocated steel posts and clamps shall be field painted two coats after the posts have been erected. The first coat shall be a zinc-dust primer paint meeting Federal Specification TT-P-641B Type II. The second coat shall be bright aluminum paint, aluminum-dust Type II, Class 3 brightness, meeting Federal Specification TT-A-468 with a minimum of 2 lb/gal, with vehicle meeting or exceeding Federal Specification TT-V-109. Scratches shall be touched up after the erection of the sign panels. The touchup shall be with both primer and finish coat. Sign pole surfaces to be painted shall be cleaned and dry when the paint is applied. No painting shall be done in damp weather nor when the air temperature is below 40°F.

645.08 Method of Measurement Demount Signs, Demount Poles, Reinstall Signs, and Reinstall Poles will be measured by each unit.

Bridge-type, cantilever and butterfly-type Sign Support Structures, including the foundations and sign panels, complete in place, as called for on the Contract Plans, will be measured by each unit.

Bridge-Mounted Guide Signs, including supports, will be measured by each unit in place.

Breakaway devices (1 per pole) shall be measured by the unit complete in place and accepted.

The area of roadside guide signs, regulatory, warning, confirmation and route marker assembly signs of the respective types, will be measured by the area in square feet, computed to nearest hundredth of a square foot, as determined by the overall height multiplied by the overall width.

Aluminum poles for roadside guide signs, Type I will be measured by the number of units of each diameter, complete in place. Steel H-beam poles will be measured for payment by the pound, determined from the nominal weight per foot for each size and the lengths as indicated on the Contract Plans.

Demountable reflectorized delineators will be measured by the number of units of each type in place.

All beacons installed on an individual post/pole shall constitute a single installation. Each installation will be measured for payment by the lump sum in place

645.09 Basis of Payment The accepted demounted signs and demounted poles will be paid for at the contract unit price each for the respective item specified. Such price will be full compensation for delivering signs and poles not to be reinstalled to a site designated by the Resident, and all other incidentals necessary to complete the work.

The accepted reinstalled signs or reinstalled poles will be paid for at the contract unit price each. Such price will be full compensation for furnishing new hardware, when required, and all incidentals necessary to complete the installations. All signs or poles designated to be reinstalled that are damaged by the Contractor shall be replaced by the Contractor with new signs or poles conforming to the applicable Specifications at no additional cost to the State.

The accepted bridge-type, cantilever and butterfly-type Sign Support Structures will be paid for at the contract lump sum price for the respective items. Such price will be full compensation for the signs, support structures, foundations, and incidentals necessary to complete the work, including design of the sign supports.

The accepted guide signs-overpass mounted, will be paid for at the contract lump sum price for the respective items, which price will be full compensation for the signs, supports and incidentals necessary to complete the work, including design of the sign supports.

The accepted roadside guide signs and regulatory, warning, confirmation, and route marker assembly signs will be paid for at the contract unit price per square foot. Such payment will be full compensation for furnishing and installing signs, assembly hardware, and all incidentals necessary to complete the work, including design of the sign supports.

The accepted aluminum poles will be paid for at the contract unit price each for the specified diameter, complete in place.

The accepted demountable reflectorized delineators will be paid for at the contract unit price each for the type specified, which payment will be full compensation for delineator and post or bridge rail mounting, complete in place.

Payment for breakaway devices shall be full compensation for furnishing and installing the device, all required pole cutting, for adapting the pole to the breakaway device, for adapting the concrete base to the breakaway device and all other incidentals necessary to complete the work. Separate payment will be made at the respective contract unit prices for demounting and reinstalling the signs and the poles at multi-pole installations. At single-pole installations, separate payment will be made at the respective contract unit prices for demounting and reinstalling the poles only.

The accepted quantity of steel H-beam poles will be paid for at the contract unit price per pound, complete in place as shown on the Contract Plans or as designated.

Furnishing and installing posts for Type II signs, including earth excavation and backfilling, furnishing and placing assembly hardware, backfilling material, loam, seed and other incidentals, will not be paid for directly but will be considered incidental to the cost of the signs they support.

Sign Mounted Beacon Arrays will be paid for at the contract lump sum price, which payment will be full compensation for furnishing all materials including, but not limited to the LED-arrays, flasher, timer, controller cabinets, wiring, pedestrian push buttons, solar panels, batteries, radio devices, radar units, and all appurtenances and incidentals required for a complete and functioning installation and for furnishing all tools and labor necessary for completing the installation. Array must meet all testing and connection requirements of this section

All work, PVC Pipe, Aggregate for Untreated Surface Course and Leveling Course, Underdrain Backfill Material and other materials furnished to install, backfill around, and fill the sleeve in the island and place the sign post in the sleeve shall be incidental to the Section 645 Items.

Payment for excavation of solid bedrock for the placement of wood poles will be made under Item 206.07.

Payment will be made under:

<u>Pay Item</u>		<u>Pay Unit</u>
645.103	Demount Guide Sign	Each
645.106	Demount Regulatory, Warning, Confirmation and Route Marker Assembly Sign	Each
645.108	Demount Pole	Each
645.113	Reinstall Guide Sign	Each
645.116	Reinstall Regulatory, Warning, Confirmation and Route Marker Assembly Sign	Each
645.118	Reinstall Pole	Each
645.12	Overhead Guide Sign: (STA X + XXX)	Lump Sum
645.13	Bridge Overpass-Mounted Guide Sign: (STA X + XXX) (Left/Right XX)	Lump Sum
645.14	Special Work No.: _____	Lump Sum
645.15	Cantilever Guide Sign: (STA X + XXX)	Lump Sum
645.161	Breakaway Device Single Pole	Each
645.162	Breakaway Device Multi Pole	Each
645.251	Roadside Guide Signs, Type I	Square Foot
645.261	Bridge Guide Sign, Type I	Square Foot
645.271	Regulatory, Warning, Confirmation and Route Assembly Sign, Type I	Square Foot
645.281	5 Inch Aluminum Pole	Each
645.282	6 Inch Aluminum Pole	Each
645.283	7 Inch Aluminum Pole	Each
645.284	8 Inch Aluminum Pole	Each
645.285	10 Inch Aluminum Pole	Each
645.286	12 Inch Aluminum Pole	Each
645.289	Steel H-Beam Poles	Pounds
645.291	Roadside Guide Signs Type II	Square Foot
645.292	Regulatory, Warning, Confirmation and Route Marker Assembly Signs Type II	Square Foot
645.301	Demountable Reflectorized Delineator, Single	Each
645.302	Demountable Reflectorized Delineator, Double	Each
645.305	Sign Mounted Beacon Array	Lump Sum

SECTION 652 MAINTENANCE OF TRAFFIC

652.2.4 Other Devices Revise this Section by removing the following paragraph:
“ STOP/SLOW paddles shall be the primary and preferred hand held signaling device. Flags shall be limited to Emergencies. The paddle shall have an octagonal shape and be at least 18 inches wide with letters at least 6 inches high and should be fabricated from semi-rigid material”

And replace with these paragraphs:

“Flaggers shall use a STOP / SLOW hand held paddle as the primary and preferred hand signaling device. Flags shall only be limited to emergencies.

STOP / SLOW paddles shall have high intensity prismatic retro reflective sheeting, have an octagonal shape on a rigid handle and shall be at least 18 inches wide with letters at least 6 inches high and shall be constructed from light semi-rigid material. The STOP (R1-1) face shall have white letters and a white border on a red background. The SLOW (W20-8) face shall have black letters and a black border on an orange background.

STOP / SLOW paddles shall also incorporate either white or red flashing lights on the STOP face and white or yellow flashing lights on the SLOW face of the paddle and always be in use. Paddles must conform to any of the following patterns:

A. Two white or red lights (colors shall be all white or all red), one centered vertically above and one centered vertically below the STOP legend; and/or two white or yellow lights (colors shall be all white or all yellow), one centered vertically above and one centered vertically below the SLOW legend;

B. Two white or red lights (colors shall be all white or all red), one centered horizontally on each side of the STOP legend; and/or two white or yellow lights (colors shall be all white or all yellow), one centered horizontally on each side of the SLOW legend;

C. One white or red light centered below the STOP legend; and/or one white or yellow light centered below the SLOW legend;

D. A series of eight or more small all white or all red lights no larger than 1/4 inch in diameter along the outer edge of the paddle, arranged in an octagonal pattern at the eight corners of the border of the STOP face; and/or a series of eight or more small all white or all yellow lights no larger than 1/4 inch in diameter along the outer edge of the paddle, arranged in a diamond pattern along the border of the SLOW face; or

E. A series of white lights forming the shapes of the letters in the legend.

Flashing light patterns shall be compliant with Section 6E.03 Hand Signaling Devices in the most current version of the Manual on Uniform Traffic Control Devices.

All flashing light patterns on the STOP / SLOW paddle shall be visible from a minimum distance of 1000 feet.”

652.3.3 Submittal of Traffic Control Plan On page 6-148, note f, in the last sentence revise the “105.2.2” to “105.2.3” so that the last sentence reads, **“For a related provision, see Section 105.2.3 – Project Specific Emergency Planning.”**

652.3.4 General Revise the eighth paragraph by removing “Earth Berm” and replace it with **“Concrete Barrier”**.

Amend this section by adding the following paragraph before the paragraph beginning with “Special Detours and temporary structures...”:

“A temporary ramp shall be constructed with HMA at the ends of the roadway section paved or milled each day. The use of millings or RAP will not be allowed, but cold patch may be temporarily utilized until HMA plants are open for the season. The maximum ramp change in

elevation shall not exceed 4” vertical. For Interstate Highways or roadways with speed limits equaling or exceeding 50 mph; temporary ramps shall be constructed at a length of eight feet per inch of transition depth. For roadways with speed limits less than 50 mph and greater than 25 mph, temporary ramps shall be constructed at a length of four feet per inch of transition depth. For roadways with speed limits 25 mph or less, temporary ramps shall be constructed at a length of two feet per inch of transition depth. Materials, placement, maintenance, and removal shall be incidental to contract items.”

652.4 Flaggers Revise this section by removing the first paragraph, and replace it with the following”

“The Contractor shall furnish flaggers as required by the TCP or as otherwise specified by the Resident. All flaggers must have successfully completed a flagger test approved by the Department and administered by a Department-approved Flagger-Certifier. All flaggers must carry an official certification card with them at all times while flagging.

For daytime conditions, flaggers shall wear a top (vest, shirt or jacket) that is orange, yellow, yellow-green, or fluorescent versions of these colors meeting ANSI 107-2004, Class 2 or Class 3, along with a hardhat with 360 ° retro-reflectivity.

For nighttime conditions, flaggers shall wear all Class 3 apparel, meeting ANSI 107-2004, including a Class 3 top (vest, shirt or jacket) and a Class E bottom (pants or coveralls), shall be worn along with a hardhat with 360 ° retro-reflectivity and shall be visible at a minimum distance of 1000 ft. Flagger stations must be illuminated in nighttime conditions to assure visibility and will be specifically addressed in detail in the Contractor’s TCP”.

652.41 TRAFFIC OFFICERS

Revise this subsection so that the subsection number and title is

“652.4.1 TRAFFIC OFFICERS”

652.6.1 Daylight Work Times Revise this section by removing the word “table” in the first sentence and replacing it with “times procured”. Also remove the link <http://www.sunrisesunset.com/usa/Maine.asp> and replace with <https://www.sunrisesunset.com/usa/Maine/>.

SECTION 654
VACANT

Change this Section to:

SECTION 654
INTELLIGENT TRANSPORTATION SYSTEMS
RESERVED

SECTION 656
TEMPORARY SOIL EROSION AND WATER POLLUTION CONTROL

656.3.4 Water Pollution Control Requirements Revise this section by adding the following to the end:

“g. Water withdrawals for dust control or moisture control for compaction is prohibited from waterbodies in Maine that have identified invasive plant infestations. For current information and a map of waterbodies where withdrawal is prohibited, visit the DEP website; <https://www.maine.gov/dep/water/invasives/>. Under the heading, “Control” there is a link to infested waterbodies. “

656.5.2 If No Pay Item Add the following to the end of the first paragraph:

“Failure by the Contractor to follow Standard Specification or Special Provision - Section 656 will result in a violation letter and a reduction in payment as shown in the schedule list in 656.5.1. The Department’s Resident or any other representative of The Department reserves the right to suspend the work at any time and request a meeting to discuss violations and remedies. The Department shall not be held responsible for any delay in the work due to any suspension under this item.”

SECTION 660 ON-THE-JOB TRAINING

660.06 Method of Measurement

Remove the first sentence in its entirety and replace with “The OJT item will be measured by the number of OJT hours by a trainee who has successfully completed an approved training program.”

660.07 Basis of payment to the Contractor

Remove the last word in the first sentence so that the first sentence reads “The OJT shall be paid for once successfully completed at the contract unit price per hour.”

Payment will be made under

Change the Pay Item from “660.22” to “660.21” and change the Pay Unit from “Each” to “Hour”.

SECTION 672 PRECAST CONCRETE BLOCK GRAVITY WALL

672.031 Concrete Units Revise this section by making the following changes:

In the second paragraph remove “A” and underline “Materials”.

In the third paragraph remove “B” and underline “Quality Control and Quality Assurance”.

Revise this section by removing the paragraph “C Construction...” and replacing it with:

“Construction. Construction requirements are modified as follows:

Add the following paragraph at the end of the Construction section:

Face texture of the units shall be a formed finish on all exposed surfaces. Pigment shall be added during the casting process of the concrete unit to achieve a consistent shade of gray or other color as determined by the Resident.

Curing. Curing requirements are modified as follows:

Replace the first sentence in the paragraph which begins “Forms shall remain ...” with the following:

The forms shall remain in place until the concrete has gained sufficient strength such that removal of the forms and subsequent handling will not damage the units.”

In the paragraph beginning with “D” remove “D” and underline “**Concrete Testing**”.

In the paragraph beginning with “E” remove the “E” and underline “**Tolerances**”. Also in this paragraph add “**Replace Tolerance contents in 712.061 with the following:**” after Tolerances.

672.035 Backfill Material– Revise this section by adding the following after the second paragraph: **Backfill materials shall meet the criteria in the following table.**

<u>Base Polymer</u>	<u>Property</u>	<u>Criteria</u>	<u>Test Method</u>
Polyester (PET)	pH	3 < pH < 9	AASHTO T-289
Polyolefin (PP & HDPE)	pH	pH > 3	AASHTO T-289

672.04 Design Requirements – Revise this section by replacing items 2 and 3 in the second paragraph with the following:

- 2. FHWA-NHI-10-024 and FHWA-NHI-10-025, Design and Construction of Mechanically Stabilized Earth Walls and Reinforced Soil Slopes, Volumes I and II, current edition.**
- 3. FHWA-NHI-09-087 Corrosion/Degradation of Soil Reinforcements for Mechanically Stabilized Earth Walls and Reinforced Soil Slopes, current edition.**

SECTION 673
WETCAST SMALL LANDSCAPE BLOCK WALL

673.031 Concrete Units Revise this section by making the following changes:

In the second paragraph remove “A” and underline “**Materials**”.

In the third paragraph remove “B” and underline “**Quality Control and Quality Assurance**”.

Revise this section by removing the paragraph “C Construction...” and replacing it with:

Construction Add the following paragraph at the end of the Construction section:

Face texture of the units shall be a formed finish on all exposed surfaces. Pigment shall be added during the casting process of the concrete unit to achieve a consistent shade of gray or other color as determined by the Resident.

Curing. Curing requirements are modified as follows:

Replace the first sentence in the paragraph which begins “Forms shall remain ...” with the following:

The forms shall remain in place until the concrete has gained sufficient strength such that removal of the forms and subsequent handling will not damage the units.”

In the paragraph beginning with “D” remove “D” and underline “**Concrete Testing**”.

In the paragraph beginning with “E” remove the “E” and underline “**Tolerances**”. Also in this paragraph add “**Replace Tolerance contents in 712.061 with the following:**” after Tolerances.

673.035 Backfill Material – Revise this section by adding the following after the second paragraph:

Backfill materials shall meet the criteria in the following table.

<u>Base Polymer</u>	<u>Property</u>	<u>Criteria</u>	<u>Test Method</u>
Polyester (PET)	pH	3 < pH < 9	AASHTO T-289
Polyolefin (PP & HDPE)	pH	pH > 3	AASHTO T-289

673.04 Design Requirements – Revise this section by replacing items 2 and 3 in the second paragraph with the following:

- 2. FHWA-NHI-10-024 and FHWA-NHI-10-025, Design and Construction of Mechanically Stabilized Earth Walls and Reinforced Soil Slopes, Volumes I and II, current edition.**
- 3. FHWA-NHI-09-087 Corrosion/Degradation of Soil Reinforcements for Mechanically Stabilized Earth Walls and Reinforced Soil Slopes, current edition**

SECTION 674

PREFABRICATED CONCRETE MODULAR GRAVITY WALL

674.02 Materials Amend this section by replacing the last sentence in the first paragraph which begins with “Materials shall...” with the following: “**Modify requirements in 712.061 as follows:**”.

Amend this section by adding the following after “Concrete Units:” and before the paragraph beginning with “Tolerances”.

Concrete shall be Class P. The concrete shall contain a minimum of 5.5 gallons per cubic yard of calcium nitrite solution.

The minimum permeability of the concrete as indicated by Surface Resistivity shall be 17 KOhm-cm.

Defects Defects which may cause rejection of precast units include, but are not limited to, the following:

Any discontinuity (crack, rock pocket, etc.) of the concrete which could allow moisture to reach the reinforcing steel.

Rock pockets or honeycomb over 6 square inches in area or over 1 inch deep.

Edge or corner breakage exceeding 12 inches in length or 1 inch in depth.

Any other defect that clearly and substantially impacts the quality, durability, or maintainability of the structure, as determined by the Fabrication Engineer.

Repair honeycombing, ragged or irregular edges and other non-structural or cosmetic defects using a patching material from the MaineDOT Qualified Products List (QPL). The repair, including preparation of the repair area, mixing and application and curing of the patching material, shall be in accordance with the manufacturer's product data sheet. Corners that are not exposed in the final product may be ground smooth with no further repair necessary if the depth of the defect does not exceed 1/2 inch. Remove form ties and other hardware to a depth of not less than 1 inch from the face of the concrete and patch the holes using a patching material from the MaineDOT QPL.

Repair structural defects only with the approval of the Fabrication Engineer. Submit a nonconformance report (NCR) to the Fabrication Engineer with a proposed repair procedure. Do not perform structural repairs without an NCR that has been reviewed by the Fabrication Engineer. Structural defects include, but are not be limited to, exposed reinforcing steel or strand, cracks in bearing areas, through cracks and cracks 0.013 inch in width that extend more than 12 inches in length in any direction. Give the QAI adequate notice prior to beginning any structural repairs.

SECTION 677

MECHANICALLY STABILIZED EARTH RETAINING WALL

677.03 Design Requirements – Revise this section by replacing items 6, 7 and 8 in the second paragraph with the following:

- 6. FHWA-NHI-10-024, Design and Construction of Mechanically Stabilized Earth Walls and Reinforced Soil Slopes, Volumes I, current edition.**
- 7. FHWA-NHI-10-025, Design and Construction of Mechanically Stabilized Earth Walls and Reinforced Soil Slopes, Volumes II, current edition.**
- 8. FHWA-NHI-09-087 Corrosion/Degradation of Soil Reinforcements for Mechanically Stabilized Earth Walls and Reinforced Soil Slopes, current edition**

On page 6 - 203 change “636.041” to “677.041”

Amend 677.042 Precast Panel Tolerances and Surface Finish by the addition of the following:

Defects Defects which may cause rejection of precast units include, but are not limited to, the following:

Any discontinuity (crack, rock pocket, etc.) of the concrete which could allow moisture to reach the reinforcing steel.

Rock pockets or honeycomb over 6 square inches in area or over 1 inch deep.

Edge or corner breakage exceeding 12 inches in length or 1 inch in depth.

Any other defect that clearly and substantially impacts the quality, durability, or maintainability of the structure, as determined by the Fabrication Engineer.

Repair honeycombing, ragged or irregular edges and other non-structural or cosmetic defects using a patching material from the MaineDOT Qualified Products List (QPL). The repair, including preparation of the repair area, mixing and application and curing of the patching material, shall be in accordance with the manufacturer's product data sheet. Corners that are not exposed in the final product may be ground smooth with no further repair necessary if the depth of the defect does not exceed 1/2 inch. Remove form ties and other hardware to a depth of not less than 1 inch from the face of the concrete and patch the holes using a patching material from the MaineDOT QPL.

Repair structural defects only with the approval of the Fabrication Engineer. Submit a nonconformance report (NCR) to the Fabrication Engineer with a proposed repair procedure. Do not perform structural repairs without an NCR that has been reviewed by the Fabrication Engineer. Structural defects include, but are not be limited to, exposed reinforcing steel or strand, cracks in bearing areas, through cracks and cracks 0.013 inch in width that extend more than 12 inches in length in any direction. Give the QAI adequate notice prior to beginning any structural repairs.

SECTION 681

PRECAST AGGREGATE-FILLED, CONCRETE BLOCK GRAVITY WALL

681.031 Concrete Units Revise this section by making the following changes:

In the second paragraph remove "A" and underline "Materials".

In the third paragraph remove "B" and underline "Quality Control and Quality Assurance".

In the fourth paragraph remove "C" and underline "Construction".

In the fifth paragraph remove "D" and underline "Concrete Testing".

In the sixth paragraph remove the "E" and underline "Tolerances".

SECTION 702

BITUMINOUS MATERIAL

702.01 Asphalt Cement - Remove this section in its entirety and replace with the following:

Performance-Graded Asphalt Binder (PGAB) that has not been modified with polymer shall conform to the requirements of AASHTO M 320. Polymer modified binder shall meet the requirements of AASHTO M 332 and AASHTO R 92, except that the percent difference in nonrecoverable creep compliance, J_{nr}diff, shall not be enforced. Performance-Graded Asphalt Binder shall not contain re-refined engine oil bottoms (REOB).

The Contractor shall arrange for the Supplier to furnish the following items to the Department's Asphalt Pavement Engineer:

a. A Quality Control Plan that conforms to the requirements of AASHTO R 26 "Certifying Suppliers of Performance-Graded Asphalt Binders" and

b. A CERTIFICATE OF ANALYSIS for all asphalt materials furnished for use on the project. The Certificate shall include the actual test results of the material in storage from which the shipments are being made. Certificates shall be supplied for each lot, batch, or blend of each type and grade of material. A new certificate shall be issued at least every 30 days or upon receiving or manufacture of a new material. The original of each Certificate of Analysis shall be mailed to the Departments Asphalt Pavement Engineer.

The Contractor shall give the supplier sufficient notice of orders to permit testing and certification. Material not certified will not be accepted for use.

Deliveries of asphalt materials shall be accompanied by a Bill of Lading containing the information required under Section 108.1.3 f. The Bill of Lading shall include the applicable certificate number and shall include a printed or stamped statement such as the following: "THIS IS TO CERTIFY THAT THE ASPHALT MATERIAL REPRESENTED BY THIS LOADING INVOICE CONFORMS TO THE SPECIFICATIONS OF THE PURCHASER FOR THE MATERIAL TYPE AND GRADE STATED THEREON."

In the event an intermediate hauler of the asphalt material is involved, a copy of their own delivery slip shall be furnished, as well as a copy of the supplier's loading invoice. The hauler's delivery slip and the supplier's loading invoice shall be cross-referenced by use of their respective serial numbers.

All non-bituminous components added to the binder prior to the sampling point for binder certification shall be included on the asphalt binder Certificate of Analysis identifying their presence. All non-bituminous components added after the certification sampling point and prior to transport shall be included on the Bill of Lading. All non-bituminous components added to the binder at the HMA plant shall be identified on the mix plant documentation and accompanied by test results and certification showing the effect of the additives introduced, if any.

702.04 Emulsified Asphalt

Revise this Section by removing the first paragraph in its entirety and replace with the following:

Emulsified Asphalt shall conform to the requirements of AASHTO M 140. Cationic emulsified asphalt shall conform to the requirements of AASHTO M 208. Anionic emulsified asphalt Grade RS-1h shall conform to the requirements in the following table:

Type	Rapid-Setting	
Grade	RS-1h	
Tests on Emulsions	min	max
Viscosity, Saybolt Furol at 25°C SFS	20	100
Storage Stability test, 24-h, % ^A	-	1.0
Demulsibility, 35 ml, 0.02 N CaCl ₂ , %	60	-
Sieve Test, % ^A	-	0.10
Residue by distillation, %	55	-
Tests on Residue from Distillation Test	min	max
Penetration, 25°C 100g, 5 s	40	90
Ductility, 25°C 5 cm/min, cm	40	-
Solubility in trichloroethylene or n-propyl bromide, %	97.5	-

^A This requirement is waived if successful application of material has been achieved in the field.

SECTION 703 **AGGREGATES**

703.01 Fine Aggregate for Concrete Replace the second paragraph with the following:

“All fine aggregate shall be free from injurious amounts of organic impurities. Should the fine aggregate, when subjected to the colorimetric test for organic impurities, AASHTO T 21, produce a color darker than organic plate number 3, the fine aggregate shall be rejected.”

703.0201 Alkali Silica Reactive Aggregates. Remove this section in its entirety and replace with the following:

All coarse and fine aggregates proposed for use in concrete shall be tested for Alkali Silica Reactivity (ASR) potential under AASHTO T 303 (ASTM C 1260), Accelerated Detection of Potentially Deleterious Expansion of Mortar Bars Due to Alkali-Silica Reaction, prior to being accepted for use. Acceptance will be based on testing performed by an accredited independent lab submitted to the Department. Aggregate submittals will be required on a 5-year cycle, unless the source or character of the aggregate in question has changed within 5 years from the last test date.

As per AASHTO T 303 (ASTM C 1260): Use of a particular coarse or fine aggregate will be allowed with no restrictions when the mortar bars made with this aggregate expand less than or equal to 0.10 percent at 30 days from casting. Use of a particular coarse or fine aggregate will be classified as potentially reactive when the mortar bars made with this aggregate expand greater than 0.10 percent at 30 days from casting. Use of this aggregate will only be allowed with the use of cement-pozzolan blends and/or chemical admixtures that result in

mortar bar expansion of less than 0.10 percent at 30 days from casting as tested under ASTM C 1567.

Acceptable pozzolans and chemical admixtures that may be used when an aggregate is classified as potentially reactive include, but are not limited to the following:

Class F Coal Fly Ash meeting the requirements of AASHTO M 295.

Ground Granulated Blast Furnace Slag (Grade 100 or 120) meeting the requirements of AASHTO M 302.

Densified Silica Fume meeting the requirements of AASHTO M 307.

Lithium based admixtures

Metakaolin

Pozzolans or chemical admixtures required to offset the effects of potentially reactive aggregates will be incorporated into the concrete at no additional cost to the Department.

703.06 Aggregate for Base and Subbase - Remove the first two paragraphs in their entirety and replace with these:

“The following shall apply to Sections (a.) and (c.) below. The material shall have a Micro-Deval value of 25.0 or less as determined by AASHTO T 327. If the Micro-Deval value exceeds 25.0, the Washington State Degradation DOT Test Method T113, Method of Test for Determination of Degradation Value (January 2009 version) shall be performed, except that the test shall be performed on the portion of the sample that passes the ½ in sieve and is retained on the No. 10 sieve. If the material has a Washington Degradation value of less than 15, the material shall be rejected.

The material used in Section (b.) below shall have a Micro-Deval value of 25.0 or less as determined by AASHTO T 327. If the Micro-Deval value exceeds 25.0 the material may be used if it does not exceed 25 percent loss on AASHTO T 96, Resistance to Degradation of Small-Size Coarse Aggregate by Abrasion and Impact in the Los Angeles Machine. “

703.081 RAP for Asphalt Pavement

Remove this section in its entirety and replace with the following:

703.081 RAP for Asphalt Pavement Recycled Asphalt Pavement (RAP) may be introduced into hot-mix asphalt pavement at percentages approved by the Department according to the MaineDOT Policies and Procedures for HMA Sampling and Testing.

If approved by the Department, the Contractor shall provide documentation stating the source, test results for average residual asphalt content, and stockpile gradations showing RAP materials have been sized to meet the maximum aggregate size requirements of each mix designation. The Department will obtain samples for verification and approval prior to its use.

The maximum allowable percent of RAP shall be determined by the asphalt content, the percent passing the 0.075 mm sieve, the ratio between the percent passing the 0.075 mm sieve and the asphalt content, and Coarse Micro-Deval loss values as tested by the Department.

The maximum percentage of RAP allowable shall be the lowest percentage as determined according to Table 4 below:

Table 4: Maximum Percent RAP According to Test Results

Classification	Maximum RAP Percentage Allowed	Asphalt content standard deviation	Percent passing 0.075 mm sieve standard deviation	Percent passing 0.075 mm sieve / asphalt content ratio	Residual aggregate M-D loss value
Class III	10%	≤ 1.0	N/A	≤ 4.0	≤ 18
Class II	20%	≤ 0.5	≤ 1.0	≤ 2.8	
Class I	30%	≤ 0.3	≤ 0.5	≤ 1.8	

The Department will monitor RAP asphalt content and gradation during production by testing samples from the stockpile at approximately 15,000 T intervals (in terms of mix production). The allowable variance limits (from the numerical average values used for mix designs) for this testing are determined based upon the maximum allowable RAP percentage, and are shown below in Table 5.

Table 5: RAP Verification Limits

Classification	Asphalt content (compared to aim)	Percent passing 0.075 mm sieve (compared to aim)
Class III	± 1.5	± 2.0
Class II	± 1.0	± 1.5
Class I	± 0.5	± 0.7

For specification purposes, RAP will be categorized as follows:

Class III – A maximum of 10.0 percent of Class III RAP may be used in any base, intermediate base, surface, or shim mixture. A maximum of 20.0 percent of Class III RAP may be used in hand-placed mixes for item 403.209.

Class II – A maximum of 20.0 percent Class II RAP in any base, binder, surface, or shim course.

Class I – A maximum of 20.0 percent Class I RAP may be used in any base, intermediate base, surface, or shim mixture without requiring a change to the specified asphalt binder. A maximum of 30.0 percent Class I RAP may be used in in any base or intermediate base mixture provided that a PG 58-28 or PG 58-34 asphalt binder is used. A maximum of 30.0 percent Class I RAP may be used in any surface or shim mixture provided that PG 58-34 asphalt binder is used. Mixtures exceeding 20.0 percent Class I RAP must be evaluated and approved by the Department.

The Contractor may use up to two different RAP sources in any one mix design. The total RAP percentage of the mix shall not exceed the maximum allowed for the highest classification RAP source used (i.e. if a Class I & Class III used, total RAP must not exceed 30.0%). The blended RAP material must meet all the requirements of the classification for which the RAP is entered (i.e. 10% Class III with 20% Class I, blend must meet Class I criteria). The Department may take belt cuts of the blended RAP to verify the material meets these requirements. If the Contractor elects to use more than one RAP source in a design, the Contractor shall provide an acceptable point of sampling blended RAP material from the feed belt.

In the event that RAP source or properties change, the Contractor shall notify the Department of the change and submit new documentation stating the new source or properties a minimum of 72 hours prior to the change to allow for obtaining new samples and approval.

703.19 Granular Borrow

Remove the gradation requirements table, and replace with the following:

Sieve Designation	Percentage by Weight Passing Square Mesh Sieves	
	Material for Underwater Backfill	Material for Embankment Construction
6 inch	100	
No. 40	0-70	0-70
No. 200	0-7.0	0-20.0

703.33 Stone Ballast - In the third paragraph, remove the words “less than” before 2.60 and add the words “or greater” after 2.60.

SECTION 705
JOINT MATERIAL

705.03 Flexible Watertight Gaskets Revise this section by deleting it in its entirety and replace with “Flexible gaskets, either rubber or plastic, shall conform to ASTM C990”

SECTION 708

PAINTS AND PRESERVATIVES

708.05 Timber Preservative Revise this section by removing it in its entirety and replacing with:
“Timber preservatives shall conform to the requirements of AASHTO M 133 and AWPA Standard U1. All preservatives shall meet the requirements of the US EPA regulations under the Federal Insecticide, Fungicide and Rodenticide Act.”

SECTION 709 REINFORCING STEEL AND WELDED STEEL WIRE FABRIC

709.01 Reinforcing Steel Revise this section by removing the sentence starting with “The chemical composition...” in the third paragraph and replace it with the following:
“The chemical composition shall conform to one of the types listed in Table 2 of ASTM A955 or UNS S32304 Duplex.”

SECTION 710 FENCE AND GUARDRAIL

710.07 Guardrail Posts Amend subsection ‘a’ by removing the words “white oak”, “cedar”, “tamarack”, “maple”, “beech”, “birch” and “red oak” from the first sentence. Also in the first sentence, place an “**or**” between “pine” and “eastern hemlock”. In the second sentence remove the words “well seasoned”. Remove the sentence beginning with “Wood posts and offset brackets...” and replace it with: **“Wood posts and offset brackets shall be preservative treated in accordance with the requirements of AASHTO M 133 and AWPA U1, UC4A Commodity Specification A: Sawn Products.”**

SECTION 712 MISCELLANEOUS HIGHWAY MATERIAL

712.061- Structural Precast Concrete Units

Under the heading, Quality Control and Quality Assurance, revise the fourth paragraph to read:

“Acceptance is the prerogative of the Department. The Department will conduct Quality Assurance (QA) in accordance with Standard Specification Subsection 106.5. Testing deemed necessary by the Department that is in addition to the minimum testing requirements will be scheduled to minimize interference with the production schedule. The QAI will perform acceptance sampling and testing and will witness or review documentation, workmanship and testing to assure the Work is being performed in accordance with the Contract Documents.”

Under the heading, Construction, revise the paragraph beginning with “Recess inserts one inch...” by removing the first sentence and replacing it with **“Recess metal inserts and form ties a minimum of one inch, unless noted otherwise in the Contract.”**

Under the heading, Concrete Testing, revise the first paragraph to read as the following two paragraphs:

“Concrete Testing Acceptance of structural precast units, for each day’s production, will be determined by the Department, based on compliance with this specification and satisfactory concrete testing results.

At least once per week, the QAI will make 2 concrete cylinders (6 cylinders when the Contract includes permeability requirements) for use by the Department; cylinders shall be standard cured in accordance with AASHTO T23 (ASTM C31). The QAI will perform entrained air content and slump flow testing, determine water-cement ratio and determine temperature of the sampled concrete at the time of cylinder casting. All testing equipment required by the QAI to perform this testing shall be in accordance with Standard Specification Section 502.041, Testing Equipment. In addition, the Contractor shall provide a slump cone meeting the requirements of AASHTO T 119. Providing and maintaining testing and curing equipment shall be considered incidental to the work and no additional payment will be made.

Quality Control test cylinders shall be made and tested in accordance with the following standards:

AASHTO T 22 (ASTM C39) Test Method for Compressive Strength of Cylindrical Concrete Specimens

AASHTO T23 (ASTM C31) Practice for Making and Curing Concrete Test Specimens in Field

AASHTO T141 (ASTM C172) Practice for Sampling Freshly Mixed Concrete

AASHTO T152 (ASTM C231) Test Method for Air Content of Freshly Mixed Concrete by the Pressure Method

AASHTO T196 (ASTM C173) Standard Test Method for Air Content of Freshly Mixed Concrete by the Volumetric Method

ASTM C1064 Test Method for Temperature of Freshly mixed Portland Cement Concrete

ASTM C1611 Standard Test Method for Slump Flow of Self-Consolidating Concrete”

Under the heading, Concrete Testing, **delete** the paragraph that begins:

“At least once per week, the Contractor shall make 2 concrete cylinders.....for use by the Department.....”

Under the heading, Concrete Testing, revise the paragraph beginning with “Perform compressive strength testing...” by replacing the word ”transfer” with the word “**stripping**”.

Under the heading, Concrete Testing, revise letter “b” to only read “Air Content shall be 5.5% to 7.5%.”

Under the heading, Surface Finish and Repairs, Revise this section by removing it and replacing it with:

“Surface Finish and Repairs. Exposed surfaces shall be finished and repaired in conformance with the referenced specification. If the finish is not specified, then surfaces shall have a uniform appearance; make repairs to remove and blend fins, patch minor spalls, tie holes, handling device recesses, entrapped air pockets, honeycombing, ragged or irregular edges and other non-structural or cosmetic defects using a patching material from the MaineDOT Qualified Products List (QPL). The repair, including preparation of the repair area, mixing and application and curing of the patching material, shall be in accordance with the manufacturer's product data sheet. Corners not exposed in the final product may be ground smooth with no further repair necessary, if the depth of the defect does not exceed one-half inch. Remove form ties and other hardware to a depth of not less than one inch from the face of the concrete and patch the holes using a patching material from the MaineDOT QPL.

Repair of structural defects: Structural defects include, but are not be limited to, exposed reinforcing steel, cracks in bearing areas, through cracks and cracks 0.013 inch in width that extend more than 12 inches in length in any direction. Repair structural defects only with the approval of the Fabrication Engineer. Submit a nonconformance report (NCR) to the Fabrication Engineer with a proposed repair procedure. Do not perform structural repairs without an NCR that has been reviewed by the Fabrication Engineer. Give the QAI adequate notice prior to beginning any structural repairs.”

SECTION 713

STRUCTURAL STEEL AND RELATED MATERIAL

Section 713.01- Structural Steel Revise this Section by removing the sentence:

“ Impact test sampling and testing procedures shall be in accordance with AASHTO T.”

And replace it with: **“Impact test sampling and testing procedures shall be in accordance with AASHTO T 243 M/T 243 and AASHTO T 244.”**

713.02 High Strength Bolts Revise this section by adding **“F3125, Grade”** after **“ASTM”** in the first and fifth paragraphs. In the fifth paragraph, remove **“They shall meet the chemical and mechanical requirements of ASTM A 325”**

SECTION 717

ROADSIDE IMPROVEMENT MATERIAL

717.02 Agricultural Ground Limestone

In the table after the third paragraph which starts with **“Liquid lime...”** change the Specification for Nitrogen (N) from **“15.5 percent of which 1% is from ammoniac nitrogen and 14.5 /5 is from Nitrate Nitrogen”** to read **“15.5 % of which 1% is from Ammoniacal Nitrogen and 14.5 % is from Nitrate Nitrogen”**

717.061 Erosion Control Blankets Revise this section by removing it in its entirety and replacing it with the following:

717.061 Erosion Control Blankets Shall consist of a machine produced rolled blanket of biodegradable fibers, evenly distributed over the entire area of blanket, of a consistent thickness, sewn into a biodegradable mesh on the top and bottom surface using a cotton blend thread. The blanket shall remain in place when subject to shear stress of 1.55 lb/ft². The blanket shall remain intact until grass is established. The blanket shall be a product currently listed on the department's Qualified Products List (QPL) of Erosion Control Products. See Section 618.10 - Seeding, Maintenance and Acceptance."

SECTION 720

STRUCTURAL SUPPORTS FOR HIGHWAY SIGNS, LUMINAIRES AND TRAFFIC SIGNALS

720.01 Aluminum Supports Revise the first paragraph by removing the words "light standards" from the last sentence. Amend this paragraph by adding "(AWS D1.2)" after "Aluminum D1.2". Further amend this section by adding the following as a new second paragraph:

"All welds shall be inspected and conform with AWS D1.2, Clause 5, Inspection. 100% of welds shall be visually examined (VT). In addition to VT, 10% of all partial joint penetration (PJP) and fillet welds shall be dye penetrant tested (PT); locations to be PT examined will be designated by the QAI. 25% of complete joint penetration (CJP) welds shall be ultrasonic tested (UT) or PT based on the thinner material in the welded joint; joints with thinner material thicknesses less than 0.25 inch shall be PT examined and joints with thinner material thickness equal or greater than 0.25 inch shall be UT examined. Locations to be UT examined will be designated by the QAI. Extent of testing shall conform with AWS D1.2, Clause 5."

720.02 Aluminum Mast Arm and Bracket Arm Revise the first paragraph by removing the words "light standards" from the last sentence. Amend this paragraph by adding "(AWS D1.2)" after "Aluminum D1.2".

Further amend this section by adding the following as a new second paragraph:

"All welds shall be inspected and conform with AWS D1.2, Clause 5, Inspection. 100% of welds shall be visually examined (VT). In addition to VT, 10% of all partial joint penetration (PJP) and fillet welds shall be dye penetrant tested (PT); locations to be PT examined will be designated by the QAI. 25% of complete joint penetration (CJP) welds shall be ultrasonic tested (UT) or PT based on the thinner material in the welded joint; joints with thinner material thicknesses less than 0.25 inch shall be PT examined and joints with thinner material thickness equal or greater than 0.25 inch shall be UT examined. Locations to be UT examined will be designated by the QAI. Extent of testing shall conform with AWS D1.2, Clause 5."

720.10 Wood Utility Pole Amend the first sentence in this section by adding ", Red Pine" after "Douglas Fir".

Replace the paragraph beginning with "Wood Utility poles..." with:

“Wood Utility poles shall be pressure treated, after fabrication in accordance with AASHTO Specifications M 133 and AWPA U1, UC4B, Commodity Specification D: Poles.”

720.12 Wood Sign Posts Remove the first sentence and replace with **“Wood sign posts shall be rectangular, straight and sound timber, cut from live growing native spruce, red pine, hemlock or cedar trees, free from loose knots or other structurally weakening defects of importance, such as shake or holes or heart rot.”**

Remove the paragraph beginning with “When pressure treated sign posts are called for on the plans ...” with **“When pressure treated sign posts are called for on the plans, the wood shall be Yellow Pine, Number 2 or better, or the species listed above. The pressure treated wood shall meet AASHTO M 133 and AWPA Standard U1, UC4A, Commodity Specification A: Sawn Products.”**



REPLY TO
ATTENTION OF

DEPARTMENT OF THE ARMY
NEW ENGLAND DISTRICT, CORPS OF ENGINEERS
696 VIRGINIA ROAD
CONCORD, MASSACHUSETTS 01742-2751

**MAINE GENERAL PERMIT (GP)
AUTHORIZATION LETTER AND SCREENING SUMMARY**

ENVIRONMENTAL OFFICE
MAINE DEPARTMENT OF TRANSPORTATION
16 STATE HOUSE STATION
AUGUSTA, MAINE 04333

CORPS PERMIT # NAE-2017-02770
CORPS GP ID# 17-655
STATE ID# PBR

DESCRIPTION OF WORK:

Place temporary fill and permanent fill below the high tide line of Rolling Dam Brook at Gardiner, Maine in order to facilitate the rehabilitation (invert lining) of an existing deteriorated bridge culvert beneath Route 24. This work will result in approximately 750 s.f. of permanent and 1,300 s.f. of temporary stream bed impact. This work is shown on the attached plans entitled "MDOT WIN 18964.00, Gardiner Route 24 - Bridge #6023, Bridge Culvert Rehabilitation" in six sheets dated "11/6/17".
Project Description Continued on Page 2

LAT/LONG COORDINATES : 44.19704° N -69.76075° W USGS QUAD: GARDINER, ME

I. CORPS DETERMINATION:

Based on our review of the information you provided, we have determined that your project will have only minimal individual and cumulative impacts on waters and wetlands of the United States. **Your work is therefore authorized by the U.S. Army Corps of Engineers under the Federal Permit, the Maine General Permit (GP).** http://www.nae.usace.army.mil/Portals/74/docs/regulatory/StateGeneralPermits/ME/Maine_General_Permit_2015.pdf

You must perform the activity authorized herein in compliance with all the terms and conditions of the GP [including any attached Additional Conditions and any conditions placed on the State 401 Water Quality Certification including any required mitigation]. Please review the enclosed GP carefully, including the GP conditions beginning on page 5, to familiarize yourself with its contents. You are responsible for complying with all of the GP requirements; therefore you should be certain that whoever does the work fully understands all of the conditions. You may wish to discuss the conditions of this authorization with your contractor to ensure the contractor can accomplish the work in a manner that conforms to all requirements.

If you change the plans or construction methods for work within our jurisdiction, please contact us immediately to discuss modification of this authorization. This office must approve any changes before you undertake them.

Condition 38 of the GP (page 16) provides one year for completion of work that has commenced or is under contract to commence prior to the expiration of the GP on October 13, 2020. You will need to apply for reauthorization for any work within Corps jurisdiction that is not completed by October 13, 2021.

This authorization presumes the work shown on your plans noted above is in waters of the U.S. Should you desire to appeal our jurisdiction, please submit a request for an approved jurisdictional determination in writing to the undersigned.

No work may be started unless and until all other required local, State and Federal licenses and permits have been obtained. This includes but is not limited to a Flood Hazard Development Permit issued by the town if necessary.

II. STATE ACTIONS: PENDING [X], ISSUED [], DENIED [] DATE _____

APPLICATION TYPE: PBR: X, TIER 1: _____, TIER 2: _____, TIER 3: _____, LURC: _____, DMR LEASE: _____, NA: _____

III. FEDERAL ACTIONS:

JOINT PROCESSING MEETING: 11/16/17 LEVEL OF REVIEW: CATEGORY 1: _____, CATEGORY 2: X

AUTHORITY (Based on a review of plans and/or State/Federal applications): SEC 10 _____, 404 _____, 10/404 X, 103 _____

EXCLUSIONS: The exclusionary criteria identified in the general permit do not apply to this project.

FEDERAL RESOURCE AGENCY OBJECTIONS: EPA_NO _____, USF&WS_NO _____, NMFS_NO _____

If you have any questions on this matter, please contact my staff at 207-623-8367 at our Augusta, Maine Project Office. In order for us to better serve you, we would appreciate your completing our Customer Service Survey located at http://corpsmapu.usace.army.mil/cm_apex/f?p=136:4:0

Jay L. Clement
JAY L. CLEMENT
SENIOR PROJECT MANAGER
MAINE PROJECT OFFICE

FRANK J. DEL GIUDICE
FRANK J. DEL GIUDICE
CHIEF, PERMITS & ENFORCEMENT BRANCH
REGULATORY DIVISION
DATE 2/14/2019



Corps of Engineers Permit No. NAE-2017-02770
Permit Conditions Resulting From
Endangered Species Act Consultation Between the Corps and the National Marine Fisheries Service
(Reference NMFS Biological Opinion dated "January 30, 2019" and
the Corps Biological Assessment ("BA") dated "December 20, 2017"
and revised "September 2018")

1. The permittee and contractor shall comply with all terms and conditions of this permit and with the permittee's construction plan. Modifications to the approved plan may require re-initiation of Endangered Species Consultation between the Corps and National Marine Fisheries Service and therefore, should not be implemented without first contacting the Corps.
2. The permittee shall hold a pre-construction meeting with appropriate Maine DOT Environmental Office staff, other DOT staff, and the DOT construction crew or contractor(s) to review all procedures and requirements for avoiding and minimizing effects to Atlantic salmon, shortnose sturgeon, and Atlantic sturgeon and to emphasize the importance of these measures for protecting Atlantic salmon and Atlantic sturgeon Critical Habitat. Corps, FHWA, and Service staff will be notified of and attend this meeting as practicable.
4. All in water work will be conducted during low tide, from October 1 to April 9 of any year.
5. The permittee and his contractor(s) shall minimize the potential for effects to Atlantic salmon and both sturgeon species and their habitat by conducting all construction activities for the project in accordance with the Maine DOT - approved Soil Erosion and Water Pollution Control Plan. Instream turbidity will be visually monitored and all erosion controls will be inspected daily to ensure that the measures taken are adequate. If inspection shows that the erosion controls are ineffective, immediate action will be taken to repair, replace, or reinforce controls as necessary.
6. All areas of temporary waterway or wetland fill will be restored to their original contour and character upon completion of the projects.
7. Disturbed areas adjacent to the waterways will be stabilized and re-vegetated with a seed mix appropriate for riparian areas in Maine.
8. All cofferdams shall be removed from the stream immediately following completion of construction, allowing for minor delays due to high stream flows following heavy precipitation, so that fish and other aquatic organism passage is not unnecessarily restricted. If the project is not completed but there will be substantial delays in construction, cofferdams will need to be at least partially removed to allow full passage of fish and other aquatic organisms until construction resumes.
9. To minimize the spread of noxious weeds into the riparian zone, all off-road equipment and vehicles (operating off of existing open and maintained roads) must be inspected and cleaned prior to entering the construction site to remove all soil, seeds, vegetation, or other debris that could contain seeds or reproductive portions of plants.
10. The permittee and his contractors shall follow measures designed to avoid and minimize effects to streams from hazardous materials associated with construction activities. These measures include but are not limited to the following:
 - a. All vehicle refueling shall occur more than 100 feet from any water course.
 - b. All vehicles carrying fuel shall have specific equipment and materials needed to contain or clean up any incidental spills at the project site. Equipment and materials would include spill kits appropriately sized for specific quantities of fuel, shovels, absorbent pads, straw bales, containment structures and liners, and/or booms.
 - c. During use, all pumps and generators shall have appropriate spill containment structures and/or absorbent pads in place.
 - d. All equipment used for instream work shall be cleaned of external oil, grease, dirt, and mud. Any leaks or accumulations of these materials would be corrected before entering streams or areas that drain directly to streams or wetlands.

11. A post-project report, confirming completion of construction and the successful application of all terms and conditions of this permit, shall be submitted within four (4) weeks of the project's completion. The report shall include, but not be limited to, a narrative and photos documenting project elements outlined in the construction plan and referenced in these conditions as well as the amount of incidental take of any listed species. This report may accompany the Compliance Certification Form referenced in Condition 13. Individual findings for each project site are required but the permittee may submit a combined report for all of the projects depending on the timing of each project's construction.

12. Maine DOT shall evaluate fish passage conditions at the rehabilitated culvert structure soon after construction, when flows are low and later at near normal flow conditions (e.g., about average annual minimum and average annual). Within 30 days of the evaluation period, the Corps and NMFS shall be provided with a summary of findings that provides information regarding depths and velocities in the structure(s) or at the inlet and outlet if culvert size limits access. The evaluation shall include stream flow measurements and photos of the culvert inlet. Photos shall be taken during the inspection to document characteristics of the culvert inlet(s), outlet(s), bed details, and the stream upstream and downstream from the road surface. Maine DOT staff shall note any channel condition changes, including scour and bedload deposition in the stream above and below the project area. Additionally, they shall assess the characteristics of the substrate deposited in the structure (including type, size, depth, and relative amounts). Velocities and depths will be compared to the results of known swimming capabilities of juvenile Atlantic salmon. Based on the summary of findings, the Corps and the Services shall determine whether subsequent long-term monitoring is required to determine if fish passage conditions and streambed morphology are stable.

13. This authorization requires you to 1) notify us before beginning work so we may inspect the project, and 2) submit a Compliance Certification Form. You must complete and return the enclosed Work Start Notification Form(s) to this office at least two weeks before the anticipated starting date. You must complete and return the enclosed Compliance Certification Form within one month following the completion of the authorized work and any required mitigation (but not mitigation monitoring, which requires separate submittals).

14. The permittee shall assure that a copy of this permit is at the work site whenever work is being performed and that all personnel performing work at the site of the work authorized by this permit are fully aware of the terms and conditions of the permit. This permit, including its drawings and any appendices and other attachments, shall be made a part of any and all contracts and sub-contracts for work which affects areas of Corps of Engineers' jurisdiction at the site of the work authorized by this permit. This shall be done by including the entire permit in the specifications for the work. If the permit is issued after construction specifications but before receipt of bids or quotes, the entire permit shall be included as an addendum to the specifications. The term "entire permit" includes permit amendments. Although the permittee may assign various aspects of the work to different contractors or sub-contractors, all contractors and sub-contractors shall be obligated by contract to comply with all environmental protection provisions of the entire permit, and no contract or sub-contract shall require or allow unauthorized work in areas of Corps of Engineers jurisdiction.

Section 3: Project Location Map

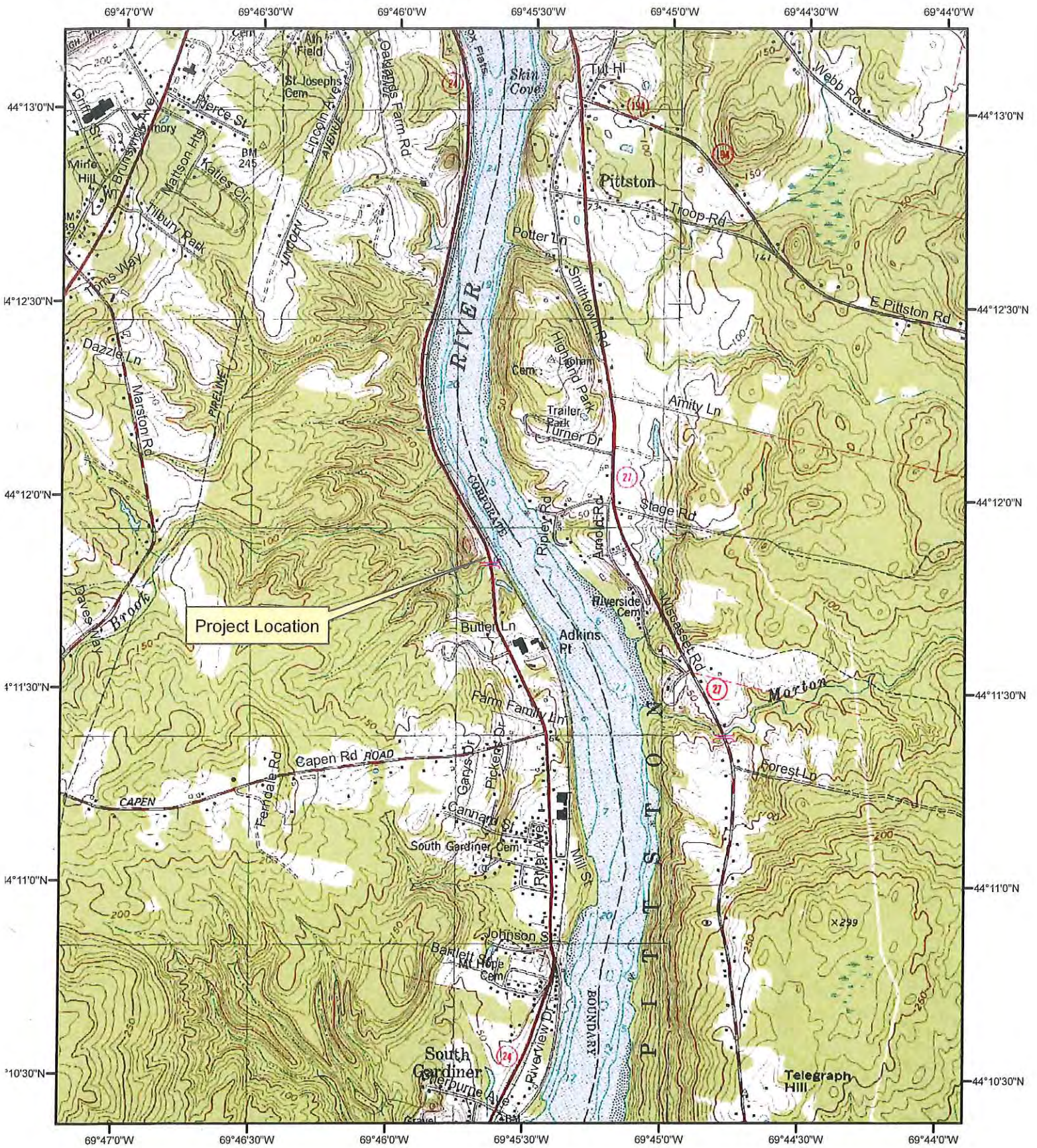

-69.76075
44.19709

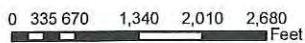

MDOT WIN 18964.00
Gardiner Route 24- Bridge # 6023
Bridge Culvert Rehabilitation
PLANS- 11/6/17



TRUST

Tax Map 21
LOT 21

MDOT WIN 18964.00
Gardiner Route 24-
Bridge # 6023
Bridge Culvert Rehabilitation
PLANS- 11/6/17



HORIZONTAL DATUM-US STATE PLANE
 FOR MAINE
 VERTICAL DATUM-NGVD 1988
 CONSIDERED FACTOR-1.00607235

DALE H. STAPLES

RUS Permanent-750 SF



RUS Temporary-1300 SF



APPROXIMATE LOCATION OF 23' COMBINED SANITARY EASEMENT AND SEWER EASEMENT (SEE BOOK 10744, PAGE 336)

12' R/W

Sewer overflow pipe outlet

EXISTING DRAINAGE

LIMITS

DIVERSION

EXISTING

SLOPE

ROLLING DAM

P.L.

CORNER LOCATION

EXISTING

LIMITS

DIVERSION

EXISTING

LIMITS

DIVERSION

EXISTING

LIMITS

DIVERSION

EXISTING

S.A.H. NO. 1

RIVER ROAD ROUTE 24

BEGIN B.L.

561.40'

+52'

ROUTE 24

CULVERT (1960)

S.H.C. FILE NO. 6-01 (1960)

EXISTING

SLOPE

EASEMENT

EXISTING

TO BE COFFER DAM-UNKNOWN LOCATION

138± S.F.

Heavy Riprap Filled Erosion Hole

TEMP. CONST. LIMITS

Heavy Riprap

Heavy Riprap (Typ.)

EXISTING CHANNEL DIVERSION LIMITS

EXISTING CHANNEL DIVERSION LIMITS

EXISTING DRAINAGE

EXISTING SLUICE



STATE OF MAINE

DALE H. STAPLES
 ITEM NO. (1)
 TEMP. CONST. RIGHTS = 138± S.F. (1)
 TOTAL AREA = 0.09± AC. (CALC.)
 (PER TAX RECORD)

DEBRA L. RUSSELL
 JOHN A. MYRICK

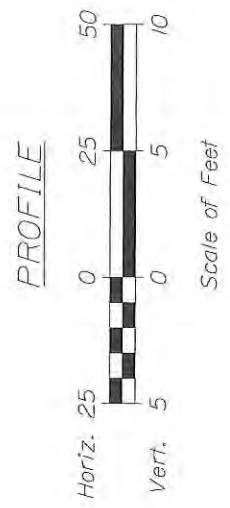
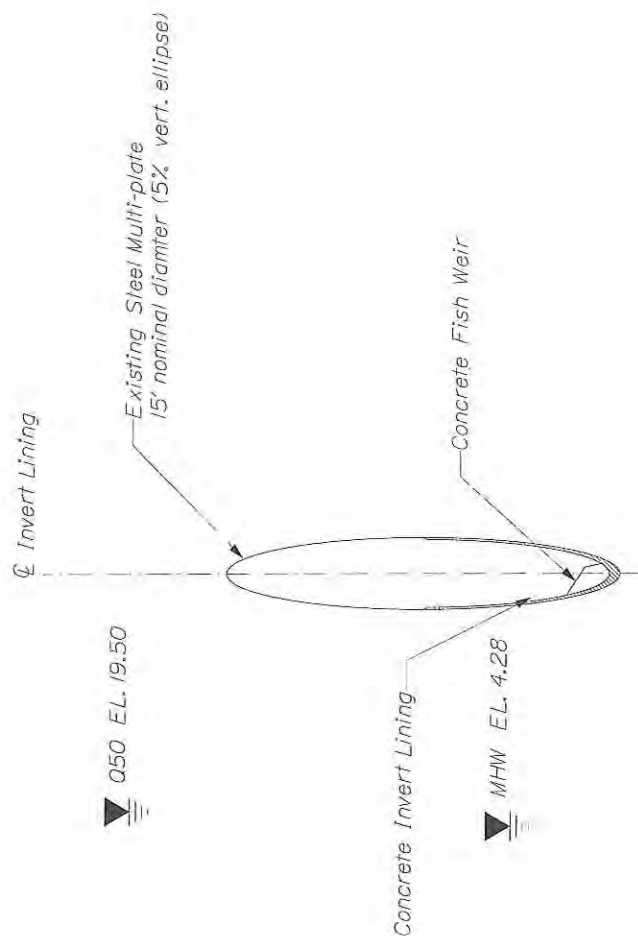
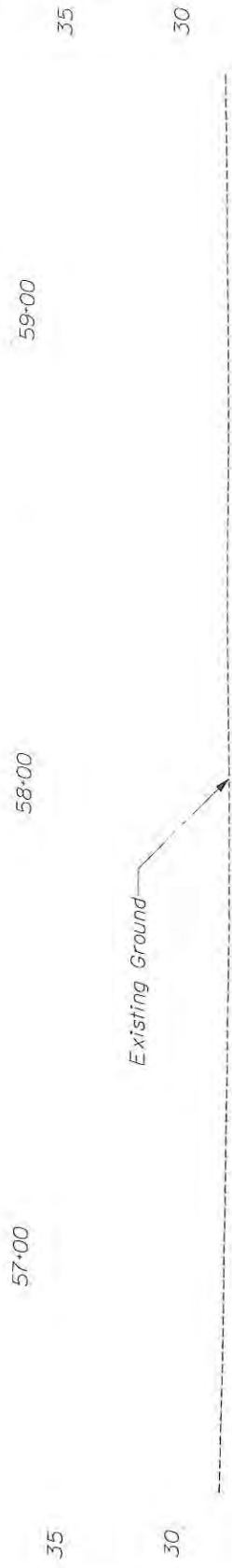

MDOT WIN 18964.00
 Gardiner Route 24-
 Bridge # 6023
 Bridge Culvert Rehabilitation
 PLANS-11/6/17

DATE	
P.E. NUMBER	
SIGNATURE	
NO.	
BY	
CHECKED	
DATE	

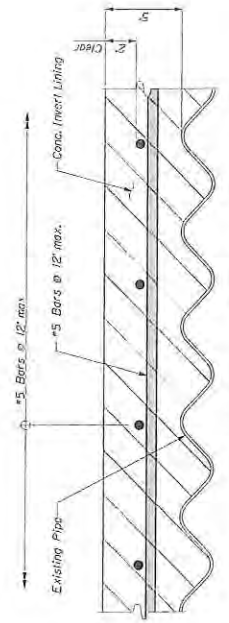

INVERT LINING SECTION

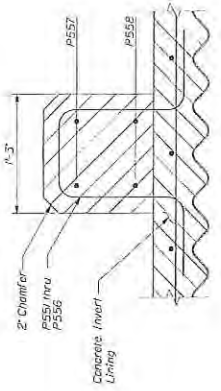

FISH WEIR SECTION
See Invert Lining Details for invert reinforcement

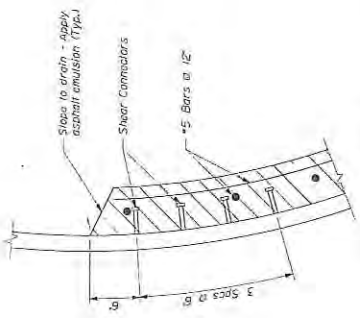

CONNECTION DETAIL

Note: Four rows of shear connectors shall be spaced longitudinally at 12" spacing along each side of the culvert. Shear connectors shall be 1/2" diameter x 3" long or machine bolts welded to the crests of the corrugations. The length of the shear connectors shall not be paid for directly. Payment will be considered incidental to item 502.325 Structural Concrete Culvert Invert Lining.

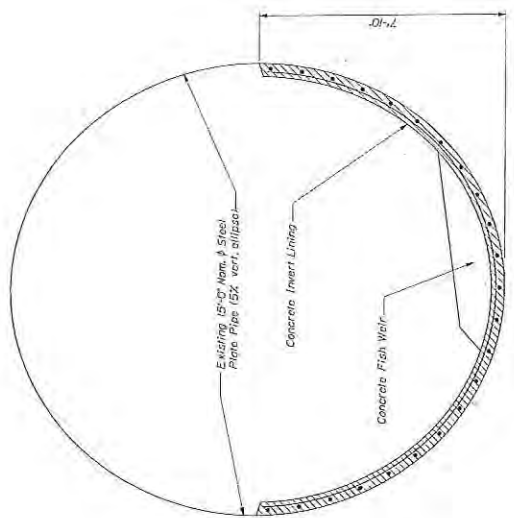
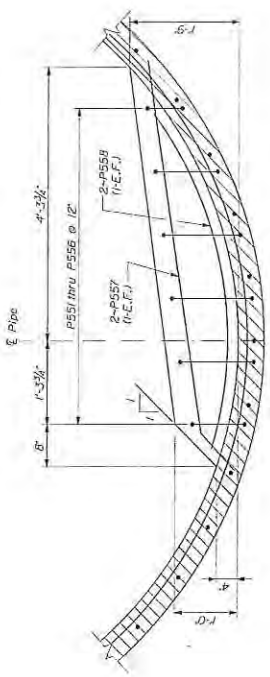

PLATE PIPE SECTION



FISH WEIR ELEVATION

Note: Section cut perpendicular to the pipe. Shows conditions such as deformation of the existing pipe and irregularities in the invert lining thickness result in control between the vertical and the horizontal dimensions shown in this detail, the vertical dimensions shall control.

MDOT WIN 18964.00
Gardiner Route 24-
Bridge # 6023
Bridge Culvert Rehabilitation
PLANS- 11/6/17

DATE	
P.E. NUMBER	
SIGNATURE	
PROJECT	ROLLING DAM NO. 2 BRIDGE
LOCATION	ROLLING DAM BROOK
COUNTY	KENNEBEC COUNTY
DESIGN	DESIGN 32 (P. 13)
REVISED	REVISED 1
REVISED	REVISED 2
REVISED	REVISED 3
REVISED	REVISED 4
REVISED	REVISED 5
REVISED	REVISED 6
REVISED	REVISED 7
REVISED	REVISED 8
REVISED	REVISED 9
REVISED	REVISED 10
REVISED	REVISED 11
REVISED	REVISED 12
REVISED	REVISED 13
REVISED	REVISED 14
REVISED	REVISED 15
REVISED	REVISED 16
REVISED	REVISED 17
REVISED	REVISED 18
REVISED	REVISED 19
REVISED	REVISED 20

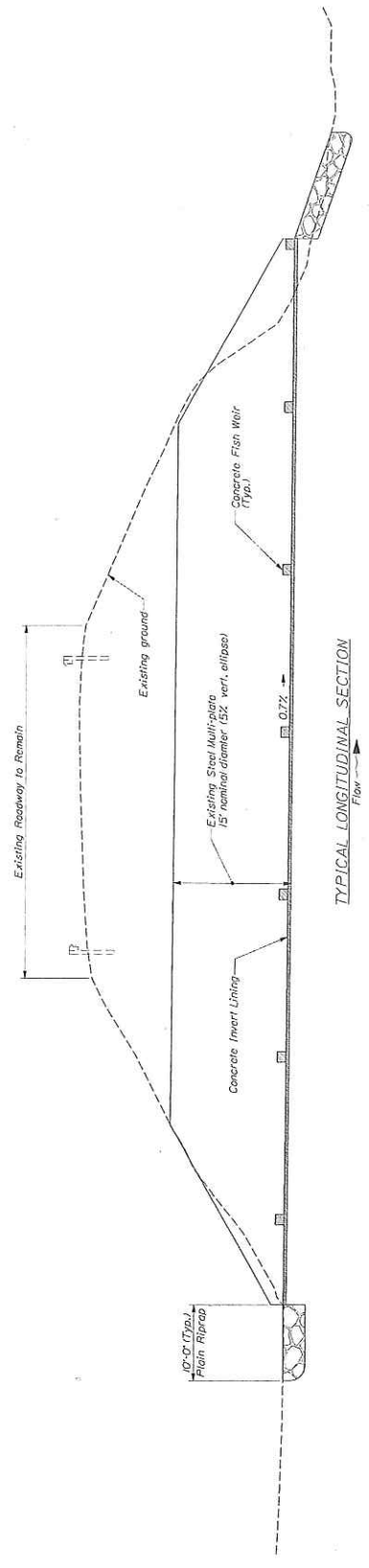
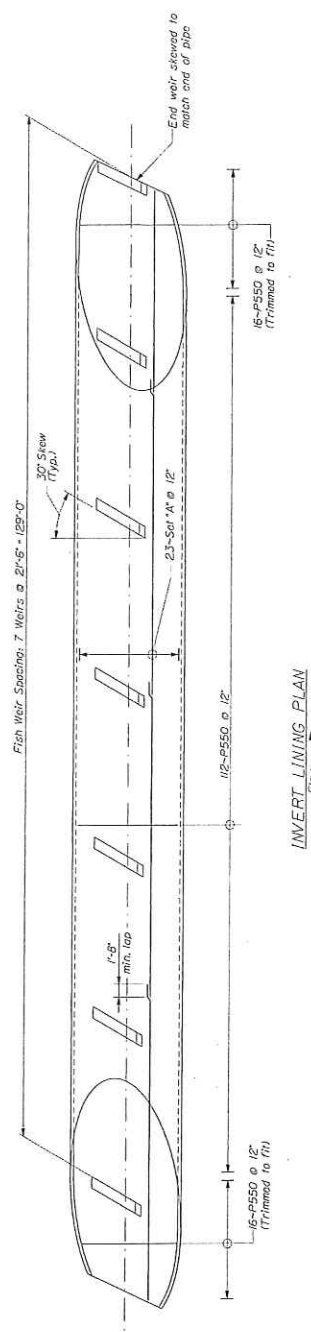

MDOT WIN 18964.00
Gardiner Route 24-
Bridge # 6023
Bridge Culvert Rehabilitation
PLANS- 11/6/17



**US Army Corps
of Engineers®**
New England District

(Minimum Notice: Permittee must sign and return notification
within one month of the completion of work.)

COMPLIANCE CERTIFICATION FORM

Permit Number: NAE-2017-02770

MaineDOT WIN 18964.00

Project Manager Clement

Name of Permittee: Maine Dept. of Transportation

Permit Issuance Date: 2/14/2019

Please sign this certification and return it to the following address upon completion of the activity and any mitigation required by the permit. You must submit this after the mitigation is complete, but not the mitigation monitoring, which requires separate submittals.

 * MAIL TO: U.S. Army Corps of Engineers, New England District *
 * Permits and Enforcement Branch C *
 * Regulatory Division *
 * 696 Virginia Road *
 * Concord, Massachusetts 01742-2751 *

Please note that your permitted activity is subject to a compliance inspection by an U.S. Army Corps of Engineers representative. If you fail to comply with this permit you are subject to permit suspension, modification, or revocation.

I hereby certify that the work authorized by the above referenced permit was completed in accordance with the terms and conditions of the above referenced permit, and any required mitigation was completed in accordance with the permit conditions.

Signature of Permittee

Date

Printed Name

Date of Work Completion

() _____
Telephone Number

() _____
Telephone Number



**US Army Corps
of Engineers®**
New England District

**GENERAL PERMIT
WORK-START NOTIFICATION FORM**
(Minimum Notice: Two weeks before work begins)

* MAIL TO: U.S. Army Corps of Engineers, New England District *
* Permits and Enforcement Branch *
* Regulatory Division *
* 696 Virginia Road *
* Concord, Massachusetts 01742-2751 *

Corps of Engineers Permit No. NAE-2018-02878 was issued to the Maine Dept. of Transportation on 2/14/19. This work is located in Rolling Dam Brook at Gardiner, Maine. The permit authorized the permittee to place temporary fill and permanent fill below the high tide line in order to facilitate the rehabilitation (invert lining) of an existing deteriorated bridge culvert beneath Route 24. This work will result in approximately 750 s.f. of permanent and 1,300 s.f. of temporary stream bed impact. **MaineDOT WIN 18964.00**

The people (e.g., contractor) listed below will do the work, and they understand the permit's conditions and limitations.

PLEASE PRINT OR TYPE

Name of Person/Firm: _____

Business Address: _____

Telephone Numbers: () _____ () _____

Proposed Work Dates: Start: _____ Finish: _____

Permittee/Agent Signature: _____ **Date:** _____

Printed Name: _____ **Title:** _____

Date Permit Issued: 2/14/19 **Date Permit Expires:** 10/13/2020

FOR USE BY THE CORPS OF ENGINEERS

PM: Clement _____ **Submittals Required:** Yes _____

Inspection Recommendation: Inspect as convenient _____

**DEPARTMENT OF THE ARMY
GENERAL PERMIT FOR
THE STATE OF MAINE**

The New England District of the U.S. Army Corps of Engineers (Corps) hereby issues a General Permit (GP) for activities subject to Corps jurisdiction in waters of the U.S. within the boundaries of the State of Maine. This GP is issued in accordance with Corps regulations at 33 CFR 320 - 332 [see 33 CFR 325.2(e)(2)]. This GP authorizes activity-specific categories of work that are similar in nature and cause no more than minimal individual and cumulative adverse environmental impacts. Refer to Page 2 for the list of activities and Appendix A for activity specific conditions of eligibility in inland and tidal waters.

I. GENERAL CRITERIA

1. In order for activities to qualify for this GP, they must meet the GP's terms and eligibility criteria (Pages 1-4), General Conditions (GC) (Pages 5 - 20), and Appendix A - Definition of Categories.
2. Under this GP, projects may qualify for the following:
 - Category 1: Category 1 Self-Verification Notification Form is required (SVNF - see Appendix B).
 - Category 2: Application to and written approval from the Corps is required (Pre-Construction Notification (PCN)). No work may proceed until written approval from the Corps is received.

If your project is ineligible for Category 1, it may qualify for Category 2 or an Individual Permit and you must submit an application (see Page 3). The thresholds for activities eligible for Categories 1 and 2 are defined in Appendix A. This GP does not affect the Corps Individual Permit review process or activities exempt from Corps regulation.

3. Prospective permittees need to read:
 - a. Section II to determine if the activity requires Corps authorization.
 - b. Sections III and IV to determine if the activity may be eligible for authorization under this GP, specifically whether it is eligible for Self-Verification (SV) or whether Pre-Construction Notification (PCN) is required.
4. Permittees must ensure compliance with all applicable General Conditions in Section IV. The Corps will consider unauthorized any activity requiring Corps authorization if that activity is under construction or completed and does not comply with all of the terms and conditions.
5. Project proponents are encouraged to contact the Corps with questions at any time. Pre-application meetings (see 33 CFR 325.1(b)), whether arranged by the Corps or requested by permit applicants, are encouraged to facilitate the review of projects. Pre-application meetings and/or site visits can help streamline the permit process by alerting the applicant to potentially time-consuming concerns that are likely to arise during the evaluation of their project (e.g., avoidance, minimization and compensatory mitigation requirements, historic properties, endangered species, essential fish habitat, and dredging contaminated sediments).

II. CORPS JURISDICTION/ACTIVITIES COVERED

1. Permits are required from the Corps of Engineers for the following work:

a. The construction of any structure in, over or under any navigable water of the United States (U.S.)¹, the excavating or dredging from or depositing of material in such waters, or the accomplishment of any other work affecting the course, location, condition, or capacity of such waters. The Corps regulates these activities under Section 10 of the Rivers and Harbors Act of 1899. See 33 CFR 322;

b. The discharge of dredged or fill material and certain discharges associated with excavation into waters of the U.S. (e.g. sidecasting). The Corps regulates these activities under Section 404 of the Clean Water Act (CWA). See 33 CFR 323; and

c. The transportation of dredged material for the purpose of disposal in the ocean. The Corps regulates these activities under Section 103 of the Marine Protection, Research and Sanctuaries Act. See 33 CFR 324.

2. Related laws:

33 CFR 320.3 includes a list of related laws, including: Section 401 of the CWA, Section 402 of the CWA, Section 307(c) of the Coastal Zone Management (CZM) Act of 1972, The National Historic Preservation Act of 1966, the Endangered Species Act, the Fish and Wildlife Act of 1956, the Marine Mammal Protection Act of 1972, Magnuson-Stevens Act, and Section 7(a) of the Wild and Scenic Rivers Act.

3. An activity listed below may be authorized by this GP only if that activity and the permittee satisfy all of the GP's terms and conditions. Any activity not specifically listed below may still be eligible for the GP; applicants are advised to contact the Corps for a specific eligibility determination. Category 1 and Category 2 eligibility criteria for each activity in both Inland and Tidal waters can be found in Appendix A.

1. Repair, Replacement, Expansion, and Maintenance of Authorized Structures and Fills
2. Moorings
3. Structures, Floats and Lifts
4. Aids to Navigation, and Temporary Recreational Structures
5. Dredging, Disposal of Dredged Material, Beach Nourishment, and Rock Removal and Relocation
6. Discharges of Dredged or Fill Material Incidental to the Construction of Bridges
7. Bank and Shoreline Stabilization
8. Residential, Commercial, Industrial, and Institutional Developments, and Recreational Facilities
9. Utility Line Activities
10. Linear Transportation Projects
11. Mining Activities
12. Boat Ramps and Marine Railways
13. Land and Water-Based Renewable Energy Generation Facilities and Hydropower Projects
14. Reshaping Existing Drainage Ditches and Mosquito Management
15. Oil Spill and Hazardous Material Cleanup
16. Cleanup of Hazardous and Toxic Waste
17. Scientific Measurement Devices
18. Survey Activities
19. Agricultural Activities
20. Fish and Wildlife Harvesting, Enhancement, and Attraction Devices
21. Habitat Restoration, Establishment and Enhancement Activities
22. Previously Authorized Activities
23. Stream & Wetland Crossings
24. Aquaculture

Note: Multiple activities may be authorized in the same GP, e.g. a recreational pier (#3) with an associated mooring (#2) or a windpower facility (#13) with an associated transmission line (#9).

¹ Defined in Appendix F, Definitions and at 33 CFR 328.
Section II

III. PROCEDURES

1. State Approvals. Applicants are responsible for applying for and obtaining any of the required state or local approvals. Federal and state jurisdictions may differ in some instances. State permits may be required for specific projects regardless of the general permit category.

In order for authorizations under this GP to be valid, when any of the following state approvals or statutorily-required reviews is also required, the approvals must be obtained prior to the commencement of work in Corps jurisdiction.

- Maine Department of Environmental Protection (DEP): Natural Resources Protection Act (NRPA) permit, including permit-by-rule (PBR) and general permit authorizations; Site Location of Development Act permit; Maine Waterway Development and Conservation Act permit; and Maine Hazardous Waste, Septage, and Solid Waste Management Act license.
- Maine Department of Conservation, Agriculture & Forestry: Land Use Planning Commission (LUPC) permit.
- Maine Department of Marine Resources: Aquaculture Leases.
- Maine Department of Conservation, Bureau of Parks and Lands, Submerged Lands: Submerged Lands Lease.

NOTE: This GP may also be used to authorize projects that are not regulated by the State of Maine (e.g., certain seasonal floats or moorings).

2. How to Obtain/Apply for Authorization.

a. Category 1 (Self-Verification): Self-Verification Notification Form (SVNF) required. The SVNF is required for all SV eligible work in Maine unless otherwise stated in Appendix A. Activities that are eligible for SV are authorized under this GP and may commence without written verification from the Corps provided the prospective permittee has:

i. Confirmed that the activity will meet the terms and conditions of Category 1. Consultation with the Corps and/or other relevant federal and state agencies may be necessary to ensure compliance with the applicable general conditions (GCs) and related federal laws such as the National Historic Preservation Act (see GC 6), the Endangered Species Act (GC 8) and the Wild and Scenic Rivers Act (GC 9). Prospective permittees are encouraged to contact the Corps with SV eligibility questions. Activities not meeting the SV criteria must submit a PCN to the Corps.

ii. Submitted the SVNF (see GC 27 and Appendix B) to the Corps. **NOTE: A copy of a state permit application form may be an acceptable surrogate for the SVNF. Whichever form chosen needs to include a location map, plans, and an Official Species List for federally listed threatened or endangered species (Reference Appendix D).**

b. Category 2 (Pre-Construction Notification (PCN)): Application to and written verification from the Corps is required before work can proceed. For activities that do not qualify for SV or where otherwise required by the terms of the GP, the permittee must submit a PCN and obtain a written permit before starting work in Corps jurisdiction.

i. The Corps will coordinate review of all activities requiring PCN with federal and state agencies and federally recognized tribes, as appropriate. To be eligible and subsequently authorized, an activity must result in no more than minimal individual and cumulative effects on the aquatic environment as determined by the Corps in accordance with the criteria listed within this GP. This may require project modifications involving avoidance, minimization, or compensatory mitigation for unavoidable impacts to ensure that the net adverse effects of a project are no more than minimal.

ii. The Corps will attempt to issue a written eligibility determination within the state's review period. Regardless, work eligible for Category 2 may not proceed before Corps written approval is received.

c. All applicants for Category 2 projects must:

- i. Apply directly to the Corps using the state application form or the Corps application form (ENG Form 4345²), and apply directly to the state (DEP, LUPC, BPL or DMR) as applicable using the appropriate state form, if the work is regulated by the Corps and the state; or
- ii. Apply directly to the Corps using the Corps application form (ENG Form 4345²) if the work is regulated by the Corps but not the state (DEP, LUPC, BPL or DMR).
- iii. Provide application information (see “Information Typically Required” in Appendix C) to help ensure the application is complete and to speed project review.
- iv. Obtain an Official Species List of federally threatened or endangered species in the project area (GC 8).
- v. Submit a copy of their application materials to the Maine Historic Preservation Commission (MHPC) *and all five Indian tribes* listed at Appendix E, at the same time, or before, they apply to the Corps, to be reviewed for the presence of historic, archaeological or tribal resources in the permit area that the proposed work may affect. Submittals to the Corps shall include information to indicate that this has been done (a copy of the applicant’s cover letter to MHPC and tribes or a copy of the MHPC and tribal response letters is acceptable).

d. Work that is not regulated by the State of Maine, but is subject to Corps jurisdiction, may still be eligible for authorization under this GP.

e. **Emergency Situations:** 33 CFR 325.2(e)4 states that an “emergency” is a situation which would result in an unacceptable hazard to life, a significant loss of property, or an immediate, unforeseen, and significant economic hardship if corrective action requiring a permit is not undertaken within a time period less than the normal time needed to process the application under standard procedures.” Emergency work is subject to the same terms and conditions of this GP as non-emergency work, and similarly, must qualify for authorization under the GP; otherwise an IP is required. The Corps will work with all applicable agencies to expedite verification according to established procedures in emergency situations.

3. Individual Permits. Projects that are not authorized by this GP require an Individual Permit (IP) (33 CFR 325.5) and proponents must submit an application directly to the Corps. This GP does not affect the Corps IP review process or activities exempt from Corps regulation. For general information and application form, see the Corps website or contact the Corps (see Appendix E). The Corps encourages applicants to apply concurrently for a Corps IP and applicable state permits.

The Corps retains discretionary authority on a case-by-case basis to elevate a GP eligible project to an IP based on concerns for the aquatic environment or for any other factor of the public interest [33 CFR 320.4(a)]. Whenever the Corps notifies an applicant that an IP is required, no work in Corps jurisdiction may be conducted until the Corps issues the required authorization in writing indicating that work may proceed.

4. Enforcement/Non-Compliance. Work performed without the required Corps of Engineers permits is subject to administrative, civil, and criminal penalties. The Corps will evaluate unauthorized activities for enforcement action under 33 CFR 326.

The Corps will consider unauthorized any activity requiring Corps authorization if that activity is under construction or completed and does not comply with all of the terms and conditions of a GP or an IP. The Corps may elect to suspend enforcement proceedings if the permittee modifies his project to comply with a GP.

After considering whether a violation was knowing or intentional, and other indications of the need for a penalty, the Corps can elect to terminate an enforcement proceeding with an after-the- fact authorization under a GP, if all terms and conditions of the GP have been satisfied, either before or after the activity has been accomplished.

² Located at www.nae.usace.army.mil/missions/regulatory under “Forms & Publications.”
Section III

IV. GENERAL CONDITIONS

To qualify for GP authorization, the prospective permittee must comply with the following general conditions, as applicable.

1. Other Permits
2. Federal Jurisdictional Boundaries
3. Minimal Direct, Secondary, and Cumulative Impacts
4. Mitigation (Avoidance, Minimization, and Compensatory Mitigation)
5. Single and Complete Projects
6. Historic Properties
7. Corps Projects and Property
8. Federal Threatened and Endangered Species
9. Wild and Scenic Rivers
10. Navigation
11. Federal Liability
12. Utility Line Installation and Removal
13. Heavy Equipment in Wetlands or Mudflats
14. Temporary Fill
15. Restoration of Special Aquatic Sites (including wetland areas).
16. Soil Erosion, Sediment and Turbidity Controls
17. Time of Year Windows/Restrictions.
18. Aquatic Life Movements & Management of Water Flows
19. Water Quality and Coastal Zone Management
20. Floodplains and Floodways
21. Storage of Seasonal Structures
22. Spawning, Breeding, and Migratory Areas
23. Vernal Pools
24. Invasive and Other Unacceptable Species
25. Programmatic Agreements
26. Permit On-Site
27. Self-Verification Notification Form (SVNF)
28. Inspections
29. Maintenance
30. Property Rights
31. Transfer of GP Verifications
32. Modification, Suspension, and Revocation
33. Special Conditions
34. False or Incomplete Information
35. Abandonment
36. Enforcement Cases
37. Duration of Authorization
38. Previously Authorized Activities
39. Discretionary Authority
40. St. John/St. Croix Rivers.
41. National Lands
42. Essential Fish Habitat (EFH)
43. Work Site Restoration
44. Bank Stabilization
45. Stream Work & Crossings and Wetland Crossings

1. Other Permits. Permittees must obtain other federal, state, or local authorizations required by law. Applicants are responsible for applying for and obtaining all required state or local approvals. This includes, but is not limited to, the project proponent obtaining a Flood Hazard Development Permit issued by the town, if necessary. Inquiries may be directed to the municipality or to the Maine Floodplain Management Coordinator at (207) 287-8063. See <http://www.maine.gov/dacf/flood/>

2. Federal Jurisdictional Boundaries

a. Applicability of this GP shall be evaluated with reference to federal jurisdictional boundaries. Applicants are responsible for ensuring that the boundaries used satisfy the federal criteria defined at 33 CFR 328 "Waters of the U.S." and 33 CFR 329 "Navigable Waters of the U.S."

NOTE: Waters of the U.S. include the subcategories "navigable waters of the U.S." and "wetlands."

b. For Category 1 projects, proponents are not required to delineate the waters of the U.S. that they plan to impact, but must approximate the square footage of impacts in order to determine the review category (1 or 2 or Individual Permit). For projects filling <15,000 square feet (SF) of waters of the U.S. that do not qualify for Category 1 (e.g., vernal pool, secondary or endangered species impacts, etc.) and therefore require an application to the Corps (PCN), and for those filling ≥15,000 SF, applicants shall delineate all waters of the U.S. that will be filled (direct impacts) in accordance with the Corps of Engineers Wetlands Delineation Manual and the most recent regional supplement (see Appendix C). In addition, applicants shall approximately identify all waters of the U.S. on the property and *known* waters adjacent to the property in order for the Corps to evaluate secondary impacts. The waters of the U.S. shall be clearly shown on the project plans submitted with the application. This includes all waters of the U.S. in areas under DEP or LUPC jurisdiction regardless of whether they're shown on LUPC zoning maps.

c. On a case-by-case basis, the Corps may modify/refine the above delineation and identification requirements for waters of the U.S. See www.nae.usace.army.mil/missions/regulatory >> Jurisdictional Limits and Wetlands for more information on delineating jurisdictional areas.

3. Minimal Direct, Secondary, and Cumulative Effects³

a. Projects authorized by this GP shall have no more than minimal direct, secondary and cumulative adverse environmental impacts. Category 2 applicants should provide information on secondary and cumulative impacts as stated in Appendix C. Compensatory mitigation may be required to offset unavoidable impacts (see GC 4) and to ensure that they are no more than minimal. Compensatory mitigation requirements will be determined on a case-by-case basis.

b. Secondary impacts to waterway and/or wetland areas, (e.g., areas drained, flooded, cleared, excavated or fragmented) shall be added to the total fill area when determining whether the project qualifies for Category 1 or 2. Direct, secondary and cumulative impacts are defined at Appendix A, Endnote 2 and Appendix F.

c. Site clearing, grading and construction activities in the upland habitat surrounding vernal pools ("Vernal Pool Management Areas") are secondary impacts. See GC 23 for avoidance and minimization requirements and recommendations.

d. Bank stabilization activities in tidal waters are provided at Appendix A, Page 30. Direct impacts in tidal waters from contiguous bank stabilization projects in excess of 200 linear feet (Applicant or Applicant + Abutters combined) must undergo Category 2 review.

4. Mitigation (Avoidance, Minimization, and Compensatory Mitigation)

a. Discharges of dredged or fill material into waters of the U.S., including wetlands, shall be avoided and minimized to the maximum extent practicable through consideration of alternatives. The Corps may require compensatory mitigation of unavoidable direct and secondary impacts associated with Category 2 projects on a case-by-case basis.

b. Applicants proposing work in jurisdictional waters should consider riparian/forested buffers for stormwater management and low impact development (LID) best management practices (BMPs) to reduce

³ Direct, secondary and cumulative effects are defined at Appendix F, Definitions and Acronyms.
Section IV

impervious cover and manage stormwater to minimize secondary impacts to aquatic resources to the maximum extent practicable.⁴

c. Compensatory mitigation⁵ for effects to waters of the U.S., including direct, secondary and temporal⁶, may be required for permanent impacts that exceed the SV area limits, and may be required for temporary impacts that exceed the SV area limits, to offset unavoidable impacts which remain after all appropriate and practicable avoidance and minimization has been achieved and to ensure that the adverse effects to the aquatic environment are no more than minimal. Proactive restoration projects or temporary impact work with no lasting secondary effects may generally be excluded from this requirement. Refer to Appendix G.

5. Single and Complete Projects⁷

a. This GP shall not be used to piecemeal work and shall be applied to single and complete projects. When determining the review category in Appendix A (Category 1 or 2) for a single and complete project, proponents must include any permanent historic fill placed since October 1995 that is associated with that project and all currently proposed temporary and permanent impact areas.

b. A single and complete project must have independent utility⁷.

c. Unless the Corps determines the activity has independent utility:

i. This GP shall not be used for any activity that is part of an overall project for which an Individual Permit is required.

ii. All components of a single project and/or all planned phases of a multi-phased project (e.g., subdivisions should include all work such as roads, utilities, and lot development) shall be treated together as constituting one single and complete project.

d. For linear projects, such as power lines or pipelines with multiple crossings, the single and complete project is all crossings of a single water of the U.S. (i.e., single waterbody) at a specific location. For linear projects crossing a single waterbody several times at separate and distant locations, each crossing is considered a single and complete project. However, individual channels in a braided stream or river, or individual arms of a large, irregularly-shaped wetland or lake, etc., are not separate waterbodies and crossings of such features cannot be considered separately. If any crossing requires a Category 2 activity, then the entire linear project shall be reviewed as one project under Category 2.

6. Historic Properties

a. No undertaking shall cause effects (defined at 33 CFR 325 Appendix C and 36 CFR 800) on properties listed on, determined to be eligible for listing on, or potentially eligible for listing on the National Register of Historic Places⁸, including previously unknown historic properties within the permit area, unless the Corps or another Federal action agency has satisfied the consultation requirements of Section 106 of the National Historic Preservation Act (NHPA). The State Historic Preservation Officer (SHPO), Tribal Historic Preservation Officer (THPO) and the National Register of Historic Places can assist with locating information on: i) previously identified historic properties; and ii) areas with potential for the presence of historic resources, which may require identification and evaluation by qualified historic preservation and/or archaeological consultants in consultation with the Corps and the SHPO and/or THPO(s).

⁴ See: www.nae.usace.army.mil/missions/regulatory >> State General Permit >> Permit Resources >> Mitigation for this additional information: a) "Wetland BMP Manual - Techniques for Avoidance & Minimization," b) riparian/forested buffer BMPs, and c) LID BMPs. LID BMPs include, but are not limited to: replacing curbs and gutters with swales; using an open space design for subdivisions; using permeable, pervious or porous pavements; constructing bio-retention systems; and/or, adding a green roof or rain garden.

⁵ Compensatory mitigation projects provided to offset losses of aquatic resources must comply with the applicable provisions of 33 CFR 332. See also the New England District Compensatory Mitigation Guidance at www.nae.usace.army.mil/regulatory >> Mitigation.

⁶ Temporal loss: The time lag between the loss of aquatic resource functions caused by the permitted impacts and the replacement of aquatic resource functions at the compensatory mitigation site(s) (33 CFR 332.2).

⁷ Single and Complete Project and Independent Utility are defined in Appendix F - Definitions.

⁸ The majority of historic properties are not listed on the National Register of Historic Places and may require identification and evaluation by qualified historic preservation and/or archaeological consultants in consultation with the Corps and the SHPO and/or THPO(s).

b. For activities eligible for SV, proponents must ensure and document that the activity will not cause effects as stated in 6(a). Proponents must submit a PCN if the authorized activity may cause effects as stated in 6(a) as soon as possible to ensure that the Corps is aware of any potential effects of the permitted activity on any historic property to ensure all Section 106 requirements are met.

c. All PCNs shall: i) show notification to the SHPO and applicable THPO(s)⁹ for their identification of historic properties, ii) state which historic properties may be affected by the proposed work or include a vicinity map indicating the location of the historic properties or the potential for the presence of historic properties, and iii) include any available documentation from the SHPO or THPO(s) indicating that there are or are not historic properties affected. Starting consultation early in project planning can save proponents time and money.

d. If you discover any previously unknown historic, cultural or archeological remains and artifacts while accomplishing the activity authorized by this permit, you must immediately notify the district engineer of what you have found, and to the maximum extent practicable, avoid construction activities that may affect the remains and artifacts until the required coordination has been completed. The district engineer will initiate the Federal, Tribal and state coordination required to determine if the items or remains warrant a recovery effort or if the site is eligible for listing in the National Register of Historic Places.

7. Corps Projects and Property

a. In addition to any authorization under this GP, proponents must contact the Corps Real Estate Division at (978) 318-8585 for work occurring on or potentially affecting Corps properties and/or Corps-controlled easements to initiate reviews and determine what real estate instruments are necessary to perform work. Permittees may not commence work on Corps properties and/or Corps-controlled easements until they have received any required Corps real estate documents evidencing site-specific permission to work.

b. Any proposed temporary or permanent alteration, or modification or use, including occupation, of a federal project (including but not limited to a levee, dike, floodwall, channel, anchorage, breakwater, seawall, bulkhead, jetty, wharf, pier or other work built but not necessarily owned by the United States), which would obstruct or impair the usefulness of the federal project in any manner, and/or would involve changes to the authorized federal project's scope, purpose, and/or functioning that go beyond minor modifications required for normal operations and maintenance, is not eligible for SV and requires review and approval by the Corps pursuant to 33 USC 408. Where Section 408 is applicable, a decision on a Department of the Army general permit application will not be rendered prior to the decision on a Section 408 request.

c. Any structure or work within any Corps Federal Navigation Project (FNP) or its buffer zone¹⁰, shall be subject to removal at the owner's expense prior to any future Corps dredging or the performance of periodic hydrographic surveys. See GC 10 for more requirements related to FNPs.

8. Federal Threatened and Endangered Species

a. No activity is authorized which: i) is likely to directly or indirectly jeopardize the continued existence of a threatened or endangered species or a species proposed for such designation, as identified under the Federal Endangered Species Act (ESA), or which will directly or indirectly destroy or adversely modify the critical habitat of such species; ii) "may affect" a listed species or critical habitat, unless Section 7 consultation addressing the effects of the proposed activity has been completed; or iii) violates the ESA.

b. **All applicants must request an Official Species List from the US Fish & Wildlife Service and must include the list in the Corps permit application. To request an Official Species List, refer to the instructions in Appendix D.**

c. **For federally listed species in tidal waters, applicants should contact the National Marine Fisheries Service at: <http://www.greateratlantic.fisheries.noaa.gov/protected/section7/>**

⁹ Appendix E, 3(a)&(b). Historic Resources, provides contact information and each tribe's "area of concern."

¹⁰ See Appendix H for a list of FNPs. The buffer zone is equal to three times the authorized depth of the FNP.
Section IV

d. A PCN is required if a threatened or endangered species, a species proposed for listing as threatened or endangered, or designated or proposed critical habitat (all hereinafter referred to as “listed species or habitat”), as identified under the ESA, is present in the action area¹¹.

e. Federal agencies should follow their own procedures for complying with the requirements of the ESA but should coordinate that consultation with the Corps as well.

9. Wild and Scenic Rivers.¹² Any activity that occurs in the designated main stem of, within 0.25 mile up or downstream of the designated main stem of, or in tributaries within .25 miles of the designated main stem of a National Wild and Scenic River, or in “bordering and contiguous wetlands” (see Appendix A, Endnote 1) that are adjacent to the designated main stem of a National Wild and Scenic River, or that has the potential to alter flows within a river within the National Wild and Scenic River System, is not eligible for Category 1 regardless of size of the impacts. This condition applies to both designated Wild and Scenic Rivers and rivers officially designated by Congress as study rivers for possible inclusion while such rivers are in an official study status. National Wild and Scenic Rivers System segments for Maine as of October 2015 include: Allagash River beginning at Telos Dam continuing to Allagash checkpoint at Eliza Hole Rapids, approximately 3 miles upstream of the confluence with the St. John River (length = 92 miles); and 11.25 miles of the York River, in the State of Maine, from its headwaters at York Pond to the mouth of the river at York Harbor, plus its tributaries (currently under study).

10. Navigation

a. Any structure or work that extends closer to the horizontal limits of any Corps Federal Navigation Project (see Appendix H) than a distance of three times the project’s authorized depth shall be subject to removal at the owner’s expense prior to any future Corps dredging or the performance of periodic hydrographic surveys. This is applicable to Category 1 and 2. Reference Appendix A, Page 28 (Mooring) and Page 29 (Structures, Floats & Lifts).

b. There shall be no unreasonable interference with navigation by the existence or use of the activity authorized herein, and no attempt shall be made by the permittee to prevent the full and free use by the public of all navigable waters at or adjacent to the activity authorized herein.

c. The permittee understands and agrees that if future U.S. operations require the removal, relocation, or other alteration of the structure or work herein authorized, or if, in the opinion of the Secretary of the Army or his authorized representative, said structure or work shall cause unreasonable obstruction to the free navigation of the navigable waters, the permittee will be required, upon due notice from the Corps, to remove, relocate, or alter the structural work or obstructions caused thereby, without expense to the U.S. No claim shall be made against the U.S. on account of any such removal or alteration.

d. A PCN is required for all work in, over or under an FNP or its buffer zone unless otherwise indicated in Appendix A. (Reference Appendix A, Endnote 13, Page 36)

11. Federal Liability. In issuing this permit, the Federal Government does not assume any liability for the following: (a) damages to the permitted project or uses thereof as a result of other permitted or unpermitted activities or from natural causes; (b) damages to the permitted project or uses thereof as a result of current or future activities undertaken by or on behalf of the U.S. in the public interest; (c) damages to persons, property, or to other permitted or unpermitted activities or structures caused by the activity authorized by this permit; (d) design or construction deficiencies associated with the permitted work; (e) damage claims associated with any future modification, suspension, or revocation of this permit.

12. Utility Line Installation and Removal

a. Subsurface utility lines shall remain subsurface. If it is necessary to discharge dredged or filled material not previously authorized in order to keep such utility lines buried or restore them to their original subsurface condition, a PCN and written verification from the Corps may be required (e.g., in the case of side

¹¹ The “Endangered Species Consultation Handbook – Procedures for Conducting Consultation and Conference Activities Under Section 7 of the ESA,” defines action area as “all areas to be affected directly or indirectly by the Federal action and not merely the immediate area involved in the action. [50 CFR 402.02].”

¹² Additional information can be found at: <http://www.rivers.gov>.

casting into wetlands from utility trenches). Certain repair, replacement or maintenance activities may be eligible for Category 1 – refer to Appendix A.

b. Subsurface utility lines must be installed at a sufficient depth to avoid damage from anchors, dredging, etc., and to prevent exposure from erosion and stream adjustment. In accordance with Corps New England District Regulation NEDER 1110-1-9 (www.nae.usace.army.mil/missions/regulatory >> [Useful Links and Documents](#)), as an absolute minimum, the bottom cover associated with the initial installation of utility lines under navigable waters and navigation channels shall be 48 inches in soil or 24 inches in rock excavation in competent rock unless specified in a written determination. These minimum bottom cover requirements for pipelines and cables shall be measured from the maximum depth of dredging to the top of the utility. The maximum depth of dredging, in waterways having existing FNP's, is generally considered to be the authorized project depth plus any allowance for advanced maintenance and the allowable overdepth for dredging tolerances. In waterways that do not have existing FNP's, this depth should be taken as two feet below the existing bottom or maximum depth of proposed dredging, as applicable.

c. Aerial utility lines that cross navigable waters must meet minimum clearances. See 33CFR322.5(i).

d. For horizontal directional drilling work, returns of drilling fluids to the surface (i.e., frac-outs) are not authorized and require restoration to the maximum extent practicable in accordance with the terms and conditions of this GP. The permittee and its contractor shall have onsite and shall implement the procedures detailed in a frac-out contingency plan for monitoring drilling operations and for the immediate containment, control and recovery/removal of drilling fluids released into the environment should a discharge of material occur during drilling operations.

e. Within the context of any new installations, any abandoned or inactive utility lines should be removed and faulty lines (e.g., leaking hazardous substances, petroleum products, etc.) should be removed or repaired to the extent practicable. A PCN and written verification from the Corps is required if they are to remain in place, e.g., to protect sensitive areas or ensure safety.

f. No work shall drain a water of the U.S. by providing a conduit for water on or below the surface. Trench plugs installed along pipelines may be effective.

13. Heavy Equipment in Wetlands or Mudflats. Operating heavy equipment other than fixed equipment (drill rigs, fixed cranes, etc.) within wetlands shall be minimized, and such equipment shall not be stored, maintained or repaired in wetlands, to the maximum extent practicable. Where construction requires heavy equipment operation in wetlands, the equipment shall either have low ground pressure (typically <3 psi), or it shall be placed on swamp/construction/timber mats (herein referred to as "construction mats" and defined at Appendix A, Endnote 4) that are adequate to support the equipment in such a way as to minimize disturbance of wetland soil and vegetation. Construction mats are to be placed in the wetland from the upland or from equipment positioned on swamp mats if working within a wetland. Dragging construction mats into position is prohibited. Other support structures that are capable of safely supporting equipment may be used with written Corps authorization (Category 2 authorization or Individual Permit). Similarly, the permittee may request written authorization from the Corps to waive use of mats during frozen, dry or other conditions. An adequate supply of spill containment equipment shall be maintained on site. Construction mats should be managed in accordance with the Construction Mat BMPs at www.nae.usace.army.mil/missions/regulatory >> State General Permits >> Permit Resources.

14. Temporary Fill. Temporary fill that qualifies for Category 1 (e.g., <15,000 SF of combined temporary and permanent fill associated with the single and complete project) or is authorized in writing under Category 2, shall adhere to the following:

a. All temporary fill and disturbed soils shall be stabilized to prevent its eroding into waters of the U.S. where it is not authorized. Work shall include phased or staged development to ensure only areas under active development are exposed and to allow for stabilization practices as soon as practicable, typically within three calendar days after disturbance. Accelerated stabilization (the providing of temporary or permanent cover by the end of the work day to prevent erosion) shall be employed as necessary. Temporary fill must be placed in a manner that will prevent it from being eroded by expected high flows.

b. Unconfined temporary fill authorized for discharge into waters of the U.S. (e.g., temporary stream crossings) shall consist of material that minimizes impacts to water quality (e.g. washed-stone, stone, etc.).

c. Appropriate measures must be taken to maintain normal downstream flows and minimize flooding to the maximum extent practicable when temporary structures, work, and discharges of dredged or fill material, including cofferdams, are necessary for construction activities, access fills, or dewatering of construction sites. Place materials in a location and manner that does not adversely impact surface or subsurface water flow into or out of the wetland. Temporary fill authorized for discharge into wetlands shall be placed on geotextile fabric or other appropriate material laid on the pre-construction wetland grade where practicable to minimize impacts and to facilitate restoration to the original grade. Construction mats are excluded from this requirement.

d. Temporary fill, construction mats and corduroy roads shall be entirely removed as soon as they are no longer needed to construct the authorized work. Temporary fill shall be placed in its original location or disposed of at an upland site and suitably contained to prevent its subsequent erosion into waters of the U.S. To qualify for Category 1, temporary fill placed during the: i.) growing season must be removed before the beginning of the next growing season; and ii.) non-growing season may remain throughout the following growing season, but must be removed before the beginning of the next growing season.

e. Temporary fill, construction mats and corduroy roads are considered temporary only if they are removed as soon as they are no longer needed to construct the authorized work.

f. Construction debris and/or deteriorated materials shall not be located in waters of the U.S.

15. Restoration of Special Aquatic Sites (Including Wetland Areas)

a. Temporary fills must be removed in their entirety and the affected areas restored to their pre-construction condition, function and elevation. Restoration shall typically commence no later than the completion of construction.

b. For excavated areas, "restored to pre-construction condition, function and elevation" means careful removal of existing soil and vegetation, separate topsoil and subsoil stockpiling, soil protection, and replacement back to the original location such that the original soil layering and vegetation schemes are approximately the same, unless otherwise authorized. Plan for natural settling that will occur (the initial post-restoration elevation of the backfilled areas should be above the desired final grade as topsoil may settle by 33% to 50%), minimize compaction, and ensure that topsoil is void of gravel and subsoil. A minimum of 4 inches of topsoil should be at the surface after the soil has settled. Wetland areas temporarily disturbed shall be stabilized (e.g., seeded or planted). Seed mixes and vegetation shall include only plant species native to New England and shall not include any species listed as "Invasive and Other Unacceptable Plant Species" in the "New England District Compensatory Mitigation Guidance" (see GC 24 and refer to Appendix G). This list may be updated periodically.

c. Limit compaction to the minimum needed to promote a successful seedbed; avoid a 'fluffy' seedbed, which is susceptible to erosion until the plants get established, and a compacted topsoil layer, which is counter-productive and will lead to greater erosion susceptibility down the road. Test soils for compaction. A soil probe, auger, or shovel should be able to retrieve samples of post-restoration profile. Equipment refusal shall be considered a failure of restoration, in which case the soil should be restored through deep-ripping and/or de-compaction, or other appropriate methods, and wetland hydrology must be maintained. See the BMPs at www.nae.usace.army.mil/missions/regulatory >> State General Permits >> Permit Resources >> Restoration.

d. In areas of authorized temporary disturbance, cut woody vegetation (trees, shrubs, etc.) shall be cut at or above ground level and not uprooted in order to prevent disruption to the wetland soil structure and to allow stump sprouts to revegetate the work area, unless otherwise authorized.

e. Trenches shall be constructed or backfilled so that the trench does not drain waters of the U.S. (e.g., materials or methods that create a French drain effect).

16. Soil Erosion, Sediment and Turbidity Controls

a. Adequate sedimentation and erosion control management measures, practices and devices, such as phased construction, installation of sediment control barriers (i.e. silt fence, vegetated filter strips, geotextile silt fences, erosion control mixes, hay bales or other devices) downhill of all exposed areas, retention of existing vegetated buffers, application of temporary mulching during construction, and permanent seeding and stabilization shall be installed and properly maintained to reduce erosion and retain sediment on-site during and after construction. They shall be capable of preventing erosion; of collecting sediment, suspended and floating materials; and of filtering fine sediment.

- b. Temporary sediment control barriers shall be removed upon completion of work, but not until all disturbed areas are permanently stabilized. The sediment collected by these sediment barriers shall be removed and placed at an upland location and stabilized to prevent its later erosion into a waterway or wetland.
- c. All exposed soil and other fills shall be permanently stabilized at the earliest practicable date .

17. Time of Year Work Windows/Restrictions. For activities where work is authorized in streams and tidal waters that causes turbidity or sediment re-suspension or other construction related disturbances, work must be conducted during the following TOY work windows (not during the TOY restrictions) unless otherwise authorized by the Corps under Category 2 review:

	<u>TOY Restriction</u> (no work)	<u>TOY Work Window</u> (work allowed)
Non-tidal waters	Oct. 01 through Jul. 14	Jul. 15 through Sep. 30
Tidal waters	Apr. 10 through Nov. 07	Nov. 08 through Apr. 09

Alternate windows authorized under Category 2 may include species specific windows recommended by the Maine Dept. of Marine Resources and/or Maine Dept. of Inland Fisheries & Wildlife.

18. Aquatic Life Movements & Management of Water Flows

a. No activity may substantially disrupt the necessary life cycle movements of those species of aquatic life indigenous to the waterbody, including those species that normally migrate through the area, unless the activity’s primary purpose is to impound water. Unless otherwise stated, activities impounding water in a stream require a PCN to ensure impacts to aquatic life species are avoided and minimized. All permanent and temporary crossings of waterbodies (e.g., streams, wetlands) shall be:

- i. Suitably culverted, bridged, or otherwise designed and constructed to maintain low flows to sustain the movement of those aquatic species; and
- ii. Properly aligned and constructed to prevent bank erosion or streambed scour both adjacent to and inside the culvert. Permanent and temporary crossings of wetlands shall be suitably culverted, spanned or bridged in such a manner as to preserve hydraulic and ecological connectivity between the wetlands on either side of the road.

b. To avoid adverse impacts on aquatic organisms, the low flow channel/thalweg shall remain unobstructed during periods of low flow, except when it is necessary to perform the authorized work.

c. To the maximum extent practicable, the pre-construction course, condition, capacity, and location of open waters must be maintained for each activity, including stream channelization and storm water management activities. The activity must be constructed to withstand expected high flows. The activity must not restrict or impede the passage of normal or high flows, unless the primary purpose of the activity is to impound water or manage high flows. The activity may alter the preconstruction course, condition, capacity, and location of open waters if it benefits the aquatic environment (e.g., stream restoration or relocation activities).

19. Water Quality and Coastal Zone Management

a. Applicants must satisfy any conditions imposed by the state and EPA, where applicable, in their CWA § 401 Water Quality Certifications (WQC) for this GP, or in any Individual § 401 WQC. See Appendix E for state-specific contact information and to determine if any action is required to obtain a 401 WQC. The Corps may require additional water quality management measures to ensure that the authorized activity does not cause or contribute to a violation of water quality standards. All projects authorized by this GP shall be designed, constructed and operated to minimize or eliminate the discharge of pollutants.

b. Applicants must satisfy any additional conditions imposed by the state in their Coastal Zone Management (CZM) Act consistency concurrences for this GP, or in any Individual CZM consistency concurrences. The Corps may require additional measures to ensure that the authorized activity is consistent with state coastal zone management requirements.

20. Floodplains and Floodways

a. Appropriate measures must be taken to minimize flooding to the maximum extent practicable.

b. Activities within 100-Year Floodplains must comply with applicable Federal Emergency Management Agency (FEMA)-approved state and/or local floodplain management permitting requirements. Proponents may need to coordinate with FEMA and apply for a formal change to the flood insurance study products or forward a set of project plans and relevant technical documentation in a digital format to the Risk

Analysis Branch Chief, Mitigation Division, FEMA, Region 1, 99 High Street, Boston, Massachusetts 02110. Applicants should provide a copy of any documentation to the Corps along with the PCN.

c. Proponents may have to obtain a Flood Hazard Development Permit issued by the town. Inquiries may be directed to the municipality or to the Maine Floodplain Management Coordinator at (207) 287-8063. See <http://www.maine.gov/dacf/flood/>

21. Storage of Seasonal Structures. Seasonal or recreational structures such as pier sections, floats, aquaculture structures, etc. that are removed from the waterway for a portion of the year (often referred to as seasonal structures) shall be stored in an upland location landward of mean high water (MHW) or ordinary high water (OHW) and not in wetlands, tidal wetlands, their substrate or on mudflats. These seasonal structures may be stored on the fixed, pile-supported portion of the structure that is waterward of MHW or OHW. Seasonal storage of structures in navigable waters, e.g., in a protected cove on a mooring, requires Corps approval and local harbormaster approval.

22. Spawning, Breeding, and Migratory Areas

a. Jurisdictional activities and impacts such as excavations, discharges of dredged or fill material, and/or suspended sediment producing activities in jurisdictional waters that provide value as fish migratory areas, fish and shellfish spawning or nursery areas, or amphibian and migratory bird breeding areas, during spawning or breeding seasons shall be avoided and minimized to the maximum extent practicable.

b. Jurisdictional activities in waters of the United States that provide value as breeding areas for migratory birds must be avoided to the maximum extent practicable. The permittee is responsible for obtaining any “take” permits required under the USFWS’s regulations governing compliance with the Migratory Bird Treaty Act or the Bald and Golden Eagle Protection Act. The permittee should contact the appropriate local office of the USFWS to determine if such “take” permits are required for a particular activity (See Appendix E).

23. Vernal Pools

a. Only vernal pools that meet the current definition of waters of the U.S. are regulated by the Corps.

b. Direct and indirect adverse effects to all vernal pools (VPs), including their envelopes and critical terrestrial habitats (VP Management Areas¹³), shall be avoided and minimized to the maximum extent practicable. Site clearing, grading, and construction activities associated with a regulated activity in the VP Management Area may cause these adverse effects to the VP.

c. The State of Maine has specific protections for vernal pools.¹⁴

d. When any regulated activities occur within 750 feet of a vernal pool, the following management practices must be followed for all work within any VP Management Area (750’ of a VP’s edge) *in order to qualify for Category I:*

- i. No disturbance within the VP Depression or VP Envelope (area within 100 feet of the VP Depression’s edge)¹⁵;
- ii. Maintain a minimum of 75% of the Critical Terrestrial Habitat (area within 100-750 feet of the VP Depression’s edge) as unfragmented forest with at least a partly-closed canopy of overstory trees to provide shade, deep litter and woody debris;
- iii. Maintain or restore forest corridors connecting wetlands and significant vernal pools;
- iv. Minimize forest floor disturbance; and
- v. Maintain native understory vegetation and downed woody debris.

¹³ The Corps VP Management Area, which includes the VP and a 750’ radius from the VP’s edge, is defined at Appendix A, Endnote 5.

¹⁴ Appendix G, 10(a)-(d) provides links to the state’s Significant Wildlife Habitat regulations and references that provide impact minimization measures to reference when designing projects.

¹⁵ The no disturbance requirement in the VP envelope [see (b)(i)(1)], and (b)(i)(2), do not apply to temporary impacts associated with construction mats in previously disturbed areas of existing utility project (e.g., transmission lines, gas pipelines) or linear transportation project (e.g., roads, highways, railways, trails, airport runways and taxiways) right-of-ways provided there is a Vegetation Management Plan that avoids, minimizes and mitigates impacts to aquatic resources.

vi. Cape Cod style-curbings or no curbing options shall be used on new roads to facilitate amphibian passage. (Reference Appendix G)

e. A PCN is required for any regulated activity within 750' of a vernal pool when all work within the VP Management Area does not comply with the Category 1 requirements in (d) above. Information on directional buffers in accordance with the VP Directional Buffer Guidance document may be provided in order to demonstrate minimal impact and avoid compensation requirements (Reference Appendix G). Conservation of the un-impacted area within the VP Management Area will often be required.

f. GC 2 requires applicants to delineate or approximately identify on the project plans all waters of the U.S., which contain vernal pools.

g. GC 23(b-d) do not apply to projects that are within a municipality and meet the provisions of a Corps-approved VP Special Area Management Plan (VP SAMP) and are otherwise eligible for self-verification.

24. Invasive and Other Unacceptable Species¹⁶

a. The introduction or spread of invasive or other unacceptable plant or animal species on the project site or areas adjacent to the project site caused by the site work shall be avoided to the maximum extent practicable. For example, construction mats and equipment shall be thoroughly cleaned and free of vegetation and soil before and after use. The introduction or spread of invasive plant or animal species on the project site caused by the site work shall be controlled.

b. No cultivars, invasive or other unacceptable plant species may be used for any mitigation, bioengineering, vegetative bank stabilization or any other work authorized by this GP. However, non-native species and cultivars may be used when it is appropriate and specified in a written verification, such as using *Secale cereale* (Annual Rye) to quickly stabilize a site. All PCNs should explain the reason for using non-native species or cultivars.

25. Programmatic Consultations or Agreements. The Corps requirements to comply with Section 106 of the NHPA, Section 7 of the Endangered Species Act or Essential Fish Habitat conservation under the Magnuson-Stevens Act may be satisfied by a Programmatic Agreement with the Corps, New England District or another federal action agency. Any Corps, New England District Programmatic Agreements will be available on our website.

26. Permit On Site. The permittee shall ensure that a copy of this GP and any accompanying authorization letter with attached plans are at the site of the work authorized by this GP whenever work is being performed and that all construction personnel performing work which may affect waters of the U.S. are aware of its terms and conditions. The entire permit authorization shall be made a part of any and all contracts and subcontracts for work that affects areas of Corps jurisdiction at the site of the work authorized by this GP. This shall be achieved by including the entire permit authorization in the specifications for work. The term "entire permit authorization" means this entire GP and the authorization letter (including its drawings, plans, appendices and other attachments) and also includes permit modifications. If the authorization letter is issued after the construction specifications, but before receipt of bids or quotes, the entire permit authorization shall be included as an addendum to the specifications. If the authorization letter is issued after receipt of bids or quotes, the entire permit authorization shall be included in the contract or subcontract. Although the permittee may assign various aspects of the work to different contractors or subcontractors, all contractors and subcontractors shall be obligated by contract to comply with all environmental protection provisions contained within the entire GP authorization, and no contract or subcontract shall require or allow unauthorized work in areas of Corps jurisdiction.

¹⁶ For the purposes of this GP, plant species that are considered invasive and unacceptable are provided in Appendix G "Invasive and other Unacceptable Plant Species" of our document "Compensatory Mitigation Guidance" at www.nae.usace.army.mil/missions/regulatory >> Mitigation. Chapter 4(e) Planting is also particularly relevant. The June 2009 "Corps of Engineers Invasive Species Policy" provides policy, goals and objectives and is located at www.nae.usace.army.mil/missions/regulatory >> Invasive Species. Additional information can be found at: www.eddmaps.org/ipane.

27. Self-Verification Notification Form (SVNF). Permittees must complete and submit the SVNF provided at Appendix B to the Corps for work authorized by this GP unless otherwise noted in Appendix A. **NOTE: A copy of a state permit application form may be an acceptable surrogate for the SVNF provided either form used also include plans and an Official Species List of federally listed threatened or endangered species.**

28. Inspections. The permittee shall allow the Corps to inspect the authorized activity at any time deemed necessary to ensure that it is being or has been accomplished in accordance with the terms and conditions of this GP and any written verification. The Corps may also require post-construction engineering drawings for completed work, post-dredging survey drawings for any dredging work, or other post-construction reports. To facilitate these inspections, the permittee shall complete and return to the Corps the following forms:

- For Category 1/Self-Verification: The SVNF (see Appendix B).
- For Category 2/PCN: The a) Work-Start Notification Form and b) Compliance Certification Form, when either is provided with the authorization letter.

29. Maintenance

a. Any authorized structure or fill shall be properly maintained, including maintenance to ensure public safety and compliance with applicable general conditions and activity-specific conditions to a written verification.

b. The requirement in (a) above does not include maintenance of dredging projects. Each maintenance dredging event exceeding the self-verification limits requires a new PCN unless an unexpired, written PCN or other Corps authorization specifies that the permittee may “dredge and maintain” an area for a particular time period. Self-verification or PCN maintenance dredging includes only those areas and depths previously authorized and actually dredged. Maintenance dredging with ocean or open water disposal will always require a PCN and at least Category 2 review.

c. Some maintenance activities may not be subject to regulation under Section 404 in accordance with 33 CFR 323.4(a)(2). Refer to Appendix A, Endnote 7.

30. Property Rights. This GP does not convey any property rights, either in real estate or material, or any exclusive privileges, nor does it authorize any injury to property or invasion of rights or any infringement of federal, state, or local laws or regulations.

31. Transfer of GP Verifications. When the structures or work authorized by this GP are still in existence at the time the property is transferred, the terms and conditions of this GP, including any special conditions, will continue to be binding on the entity or individual who received the GP authorizations, as well as the new owner(s) of the property. If the permittee sells the property associated with a GP verification, the permittee may transfer the GP verification to the new owner by submitting a letter to the Corps (see Appendix E for address) to validate the transfer. A copy of the GP verification must be attached to the letter, and *the letter must contain the new owner’s contact information and the following statement and signature:*

“When the structures or work authorized by this GP are still in existence at the time the property is transferred, the terms and conditions of this GP, including any special conditions, will continue to be binding on the new owner(s) of the property. To validate the transfer of this GP and the associated liabilities associated with compliance with its terms and conditions, have the transferee sign and date below.”

(Transferee)

(Date)

32. Modification, Suspension, and Revocation. Any work authorized under this GP by self-verification or PCN may be either modified, suspended, or revoked, in whole or in part, pursuant to the policies and procedures of 33 CFR 325.7. Any such action shall not be the basis for any claim for damages against the U.S.

33. Special Conditions. The Corps may independently, or at the request of the federal resource agencies, impose other special conditions on a project authorized pursuant to this GP that are determined necessary to minimize adverse navigational and/or environmental effects or based on any other factor of the public interest. Failure to comply with all terms and conditions of the authorization, including special conditions, constitutes a permit violation and may subject the permittee to criminal, civil or administrative penalties and/or an ordered restoration.

34. False or Incomplete Information. If the Corps makes a determination regarding the eligibility of a project under this GP and subsequently discovers that it has relied on false, incomplete or inaccurate information provided by the permittee, the Corps may determine that the GP authorization is not valid; modify, suspend or revoke the authorization; and the U.S. Government may institute legal proceedings.

35. Abandonment. If the permittee decides to abandon the activity authorized under this GP, unless such abandonment is merely the transfer of property to a third party, he/she may be required to restore the area to the satisfaction of the Corps.

36. Enforcement cases. This GP does not apply to any existing or proposed activity in Corps jurisdiction associated with an ongoing Corps or EPA enforcement action, until such time as the enforcement action is resolved or the Corps or EPA, as appropriate, determines that the activity may proceed independently without compromising the enforcement action.

37. Duration of Authorization. This GP expires on October 12, 2020. Activities authorized under this GP that have commenced (i.e., are under construction) or are under contract to commence before this GP expires will have until October 12, 2021 to complete the activity under the terms and conditions of the current GP.

38. Previously Authorized Activities.

a. Projects that have received authorization (Category 1 or 2) from the Corps and that were completed under the previous PGPs, nationwide permits, regional general permits or letters of permission, shall remain authorized.

b. Activities authorized pursuant to 33 CFR Part 330.3 (“Activities occurring before certain dates”) are not affected by this GP.

c. Any work not commenced nor completed that was authorized in a written letter from the Corps under the GP in effect between October 12, 2010 and October 12, 2015 remains authorized subject to the terms and general conditions of this GP along with any special conditions in the authorizing written letter. Exception – if previously authorized work is not commenced and a new federally listed threatened or endangered species could be affected, the Corps must consult with the Service(s) prior to re-authorizing the work under this GP. Requests for re-authorization must include an updated Official Species list. To request an Official Species List, refer to the instructions in Appendix D.

39. Discretionary Authority. Notwithstanding compliance with the terms and conditions of this permit, the Corps retains discretionary authority to require Category 2 or Individual Permit review based on concerns for the aquatic environment or for any other factor of the public interest [33 CFR 320.4(a)]. This authority is invoked on a case-by-case basis whenever the Corps determines that the potential consequences of the proposal warrant a higher level of review based on the concerns stated above. This authority may be invoked for projects that may contribute to cumulative environmental impacts that are more than minimal or if there is a special resource or concern associated with a particular project that is not already covered by the remaining conditions of the GP and that warrants greater review. Whenever the Corps notifies an applicant that an Individual Permit may be required, the project is not authorized under this GP and no work may be conducted until an Individual Permit is obtained or until the Corps notifies the applicant that further review has demonstrated that the work may proceed under this GP.

40. St. John/St. Croix Rivers. Work within the Saint John and Saint Croix River basins that requires approval of the International Joint Commission is not eligible for Category 1 and a PCN to the Corps is required if any temporary or permanent use, obstruction or diversion of international boundary waters could affect the natural

flow or levels of waters on the Canadian side of the line; or if any construction or maintenance of remedial works, protective works, dams, or other obstructions in waters downstream from boundary waters could raise the natural level of water on the Canadian side of the boundary.

41. National Lands. Activities that impinge upon the value of any National Wildlife Refuge, National Forest, National Marine Sanctuary, National Park or any other area administered by the National Park Service, U.S. Fish and Wildlife Service (USFWS) or U.S. Forest Service are not eligible for Category 1 and require a PCN.

42. Essential Fish Habitat (EFH). Any work in the following rivers and streams, including all tributaries to the extent that they are currently or were historically accessible for salmon migration, shall not be authorized under Category 1 of the GP and must be screened for potential impacts to EFH (see Appendix G for more information).

Androscoggin River	Aroostook River	Boyden River	Dennys River
Ducktrap River	East Machias River	Hobart Stream	Kennebec River
Machias River	Narraguagus River	Orland River	Passagassawaukeag River
Patten Stream	Penobscot River	Pleasant River	Presumpscot River
Saco River	Sheepscot River	St. Croix River	Tunk Stream
			Union River

The above does not apply to the following activities which may qualify for Category 1 work:

- Exploratory drilling and borings for bridges.
- Moorings (see Appendix A, Page 28 for Category 1 thresholds and requirements)
- Structures, floats & lifts (see Appendix A, Page 29 for Category 1 thresholds and requirements)
- Other activities specified in a programmatic agreement with NMFS.

43. Work Site Restoration

a. Wetland areas where permanent disturbance is not authorized shall be restored to their original condition and elevation, which under no circumstances shall be higher than the pre-construction elevation. Original condition means careful protection and/or removal of existing soil and vegetation, and replacement back to the original location such that the original soil layering and vegetation schemes are approximately the same, unless otherwise authorized.

b. Upon completion of construction, all disturbed wetland areas (the disturbance of these areas must be authorized) shall be properly stabilized. Any seed mix shall contain only plant species native to New England and shall not contain any species listed in the "Invasive and Other Unacceptable Plant Species" Appendix in the "New England District Compensatory Mitigation Guidance" (see GC 24 and refer to Appendix G). This list may be updated periodically.

c. In areas of authorized temporary disturbance, if trees are cut they shall be cut at ground level and not uprooted in order to prevent disruption to the wetland soil structure and to allow stump sprouts to revegetate the work area, unless otherwise authorized.

44. Bank Stabilization

a. Projects involving construction or reconstruction/maintenance of bank stabilization structures within Corps jurisdiction shall be designed to minimize environmental effects, effects to neighboring properties, scour, etc. to the maximum extent practicable.

b. Project proponents must design and construct bank stabilization projects using this sequential minimization process: avoidance of aquatic resource impacts, diversion of overland flow, vegetative stabilization, stone-sloped surfaces, and walls/bulkheads. Vertical walls/bulkheads shall only be used in situations where reflected wave energy can be tolerated.

c. Inland Water bank stabilization activities necessary for erosion prevention must meet all of the following criteria: i) No material is placed in excess of the minimum needed for erosion protection; ii) The activity is no more than 500 feet in total length along the bank(s); iii) The activity will not exceed an average of one cubic yard per running foot placed along the bank below the plane of the ordinary high water mark; iv) Structures angled steeper than 1H:1V and any material other than angular or sub-angular stone or fiber roll revetments require at least a Category 2 review; v) The activity does not involve discharges of dredged or fill

Section IV

material into special aquatic sites; vi) No material is of the type, or is placed in any location, or in any manner, to impair surface water flow into or out of any water of the U.S.; vii) No material is placed in a manner that will be eroded by normal or expected high flows (properly anchored trees and treetops may be used in low energy areas); and viii) The activity is not a stream channelization activity.

d. Bank stabilization activities in tidal waters are provided at Appendix A, Page 30 & 31. Direct impacts in tidal waters from contiguous bank stabilization projects in excess of 200 linear feet (Applicant or Applicant + Abutters combined) must undergo Category 2 review.

45. Stream Work and Crossings & Wetland Crossings

Notes:

a. For *Stream Work and Crossings* below, conditions (a) and (b) apply to Inland Waters and Wetlands (see Appendix A, Page 1 for definition) and Navigable Waters (see Appendix A, Page 27 for definition). Conditions (c)-(I) below only apply to Inland Waters and Wetlands that are streams. All new and replacement crossings in Navigable Waters require an application to the Corps and at least a Category 2 review.

b. In-stream work in a watershed occupied by listed Atlantic salmon, Atlantic sturgeon, or shortnose sturgeon [see GC 8(b)] and some stream work such as crossings on EFH waters (see GC 42) is not eligible for Category 1.

c. “High-Quality Stream Segments” are shown at www.maine.gov/dep/gis/datamaps and may be useful in evaluating impacts to fisheries. GIS shape files are under “Other Google Earth Interactive Maps” and PDFs by county are under “DEP GIS Maps.” See Appendix E for more state contact information.

Conditions for Stream Work and Crossings:

a. All permanent crossings of rivers, streams, brooks, etc. (hereon referred to as “streams”) shall be suitably culverted, bridged, or otherwise designed to i) withstand and to prevent the restriction of high flows to qualify for Category 1, and ii) not obstruct the movement of or not substantially disrupt the necessary life-cycle movements of those species of aquatic life indigenous to the waterbody, including those species that normally migrate through the area, beyond the actual duration of construction unless the activity’s primary purpose is to impound water to qualify for Category 1 or 2. (NOTE: *Areas of fill and/or cofferdams must be included in total waterway/wetlands impacts to determine applicability of this GP*).

b. Any work that temporarily or permanently impacts upstream or downstream flood conditions, or permanently impacts wetlands in excess of Category 1 thresholds, must be reviewed at least under Category 2. See the documents referenced in Appendix G, 8(c) and (d) for guidance.

c. New Stream Crossings. For new stream crossings to qualify for Category 1:

i. Must ensure compliance with GC 45(a) and GC 45(b) above.

ii. Shall be designed and constructed in accordance with the Corps General Stream Crossing

Standards provided on Page 19 and the stream simulation document listed at Appendix G, 8(a).

d. Replacement Stream Crossings. For replacement stream crossings to qualify for Category 1:

i. Must ensure compliance with GC 45(a) and GC 45(b) above.

ii. Shall be designed and constructed in accordance with the Corps General Stream Crossing

Standards provided on Page 19 and the stream simulation document listed at Appendix G, 8(a).

e. Culvert Extensions. Culvert extensions on culverts that do not meet the Corps General Stream Crossing Standards do not qualify for Category 1 and require an application to the Corps and at least Category 2 review.

f. Temporary Stream Crossings.

Note: The General Stream Crossing Standards don’t apply to temporary stream crossings.

i. Temporary stream crossings or cofferdams shall be used for equipment access across streams [see Appendix G, 8(e)]. Note: Areas of fill and/or cofferdams must be included in total waterway/wetlands impacts to determine the review category in Appendix A.

ii. Temporary stream crossings shall be removed within 180 days to qualify for Category 1.

iii. Temporary stream crossings that are not spans¹⁷ (typically culverts) must be designed in accordance with 1-6 below to qualify for Category 1. Category 2 applications should include information demonstrating 2-6 below:

1. Installed and removed during the low flow period specified in GC 45(l) below.
2. Placed on geotextile fabric or other material where practicable to ensure restoration to the original grade. Soil may not be used to construct or stabilize these structures and rock must be large enough to allow for easy removal without disrupting the streambed.
3. Designed and maintained to withstand and pass high flows. Water height should be no higher than the top of the culvert's inlet. A minimum culvert diameter of two feet is required to pass debris. Culverts must be aligned to prevent bank erosion or streambed scour.
4. Equipped with energy dissipating devices installed downstream if necessary to prevent scour.
5. Designed and maintained to prevent soil from entering the waterbody.
6. Removed upon the completion of work. Impacts to the streambed or banks requires restoration to their original condition using stream simulation methods¹⁸.

g. Slip Lining. Work using slip lining (retrofitting an existing culvert by inserting a smaller diameter pipe), invert lining, or resulting in decreased diameter, does not qualify for Category 1, either as new work or maintenance activities.

h. Work in Flowing Waters. To qualify for Category 1, no unconfined fill [see GC 14(b)] or excavation in flowing waters is allowed. To accomplish this:

i. Bank stabilization work below ordinary high water (OHW) shall utilize erosion controls such as inflatable cofferdams, jersey barrier, silt screen, turbidity curtain, etc. where practicable to prevent sediment input to the stream and to minimize turbidity and sedimentation impacts for sensitive life stages. Bank stabilization above OHW must utilize erosion controls.

ii. Management techniques such as temporary flume pipes, culverts, cofferdams, etc. must be used to maintain normal flows within the stream boundary's confines, or water diversions may be used immediately up and downstream of the work footprint (see Appendix A, Endnote 6) or work must be performed in the dry under no flow conditions, or under very low flow conditions following the practices in GC 45(a).

i. Minimization. In order to make the Category 2 review process more efficient and result in a faster decision, new and replacement stream crossings should be designed using the least intrusive and environmentally damaging method following this sequential minimization process: 1) spans with no stream impacts, 2) spans with stream impacts, and 3) embedded culverts with stream simulation or low-slope design.

j. Maintenance Requirements. The permittee shall maintain the work authorized herein in good condition and in conformance with the terms and general conditions of this permit to facilitate aquatic life passage as stated in GC 45(a). Culverts that develop "hanging" inlets or outlets, result in bed washout, or a stream that doesn't match the characteristics of the substrate in the natural stream channel such as mobility, slope, stability confinement will require maintenance or repair to comply with this GC. This does not apply to GC 45(f) above.

k. Maintenance and Replacement Information. An existing stream crossing must be authorized and in compliance with all conditions of its authorization(s) to qualify for maintenance not subject to regulation. See Appendix A, Endnote 7. A non-serviceable crossing is not eligible for maintenance and is therefore considered as a replacement crossing [see GC 45(d)].

l. Work Window. For projects that otherwise meet the terms of Category 1, in-stream construction work shall be conducted during the low flow period July 15 – September 30 in any year. Projects that are not to be conducted during that time period are ineligible for Category 1 and shall be screened pursuant to Category 2, regardless of the waterway and wetland fill and/or impact area.

Corps General Stream Crossing Standards (required for Category 1; recommended for Category 2):

- a. Culverts must be embedded:

¹⁷ For the purposes of this GP, spans are bridges, three-sided box culverts, open-bottom culverts or arches that span the stream with footings landward of bankfull width.

¹⁸ Design and construction shall be in accordance with the stream simulation document listed at Appendix G, 8(a).

- ≥ 2 feet for box culverts and other culverts with smooth internal walls,
- ≥ 1 foot for corrugated pipe arches
- ≥ 1 foot and at least 25 percent for corrugated round pipe culverts

b. **For new crossings**, spans¹⁷ are required to avoid or cause minimal disruption to the streambed and to meet the requirements of General Condition 45(a) and 45(b). Footings and abutments must be landward of 1.2 times bankfull width. To the greatest extent practicable, work in the stream shall be minimized, and design and construction shall allow the streambed's natural structure and integrity to remain intact. Any fill or excavation of the streambed below bankfull width other than footings, support pilings, or work specified in 45(h)ii requires Category 2 review and, unless demonstrated otherwise, stream simulation¹⁸ to establish substrate and banks in the span structure and work area as specified in (d) and (e) below.

c. **For replacement crossings**, spans¹⁷ are required to meet the requirements of General Condition 45(a) and 45(b). Footings and abutments shall be landward of 1.2 times bankfull width. Unless demonstrated otherwise, stream simulation¹⁸ is required to establish substrate and banks in the span structure and work area as specified in (d) and (e) below.

d. Crossings must have a natural bottom substrate within the structure matching the characteristics of the substrate in the natural stream channel and the banks (mobility, slope, stability, confinement, grain and rock size) at the time of construction and over time as the structure has had the opportunity to pass significant flood events. To allow terrestrial passage for wildlife and prevent undermining the footings, crossings shall have a bank on both sides of the stream matching the horizontal profile of the existing stream and banks¹⁸. Note: Installation of substrate material within smaller culverts may not be safe or practicable. In these cases, it may be necessary to allow for natural deposition and bed development unless alternative methods are identified.

e. Crossings must be designed and constructed¹⁸ with appropriate bed forms and streambed characteristics so that water depths and velocities are comparable to those found in the natural channel at a variety of flows. In order to provide appropriate water depths and velocities at a variety of flows and especially low flows, it is usually necessary to reconstruct the streambed or preserve the natural channel within the structure. Otherwise, the width of the structure needed to accommodate higher flows will create conditions that are too shallow at low flows. The grain and rock size, and arrangement of streambed materials within the structure should be in accordance with (d) above. Flows could go subsurface within the structure if only large material is used without smaller material filling the voids.

Conditions for Wetland Crossings:

a. All temporary and permanent crossings of wetlands shall be suitably culverted, bridged, or otherwise designed to: i) Withstand and prevent the restriction of high flows, ii) Not obstruct the movement of or not substantially disrupt the necessary life-cycle movements of those species of aquatic life indigenous to the wetland, including those species that normally migrate through the area, beyond the actual duration of construction unless the activity's primary purpose is to impound water. See Appendix E for the Maine DEP's crossing standards.

b. To qualify for Category 1, new and replacement wetland crossings that are permanent shall be culverted, spanned or bridged in such a manner as to preserve hydraulic and ecological connectivity, at its present level, between the wetlands on either side of the road. To meet this requirement, we recommend that culverts, spans or bridges be placed at least every 50 feet with an opening at least 2 feet high and 3 feet wide at ground level where practicable. Closed bottom culverts shall be embedded at least 6 inches with a natural bottom.

c. In the case of non-compliance, the permittee shall take necessary measures to correct wetland damage due to lack of hydraulic and ecological connectivity.

d. Any work that results in flooding, results in impacts to wetlands on either side of the wetland crossing in excess of Category 1 thresholds, or impacts wetland drainage from the upgradient side of the wetland crossing does not qualify for Category 1.

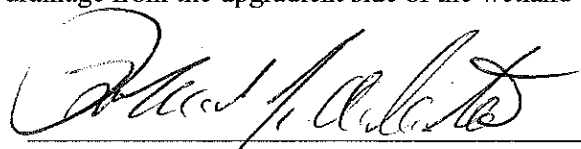

Robert J. Desista
Deputy Chief, Regulatory Division
For DISTRICT ENGINEER

DATE
 10/13/15

APPENDIX A: DEFINITION OF CATEGORIES

<p>A. INLAND WATERS AND WETLANDS</p>	<p>Inland Waters and Wetlands: Waters that are regulated under Section 404 of the Clean Water Act, including rivers, streams, lakes, ponds and wetlands, and <i>excluding Section 10 Navigable Waters of the U.S. (tidal and freshwater)</i>. The jurisdictional limits are the ordinary high water (OHW) mark in the absence of adjacent wetlands, beyond the OHW mark to the limit of adjacent wetlands when adjacent wetlands are present, and the wetland limit when only wetlands are present. For the purposes of this GP and designated wetlands¹ to tidal waters are reviewed in the Navigable Waters section. (See B. Navigable Waters on page 27 below.)</p> <p>Projects not meeting Category 1 require an application for review as a Category 2 or Individual Permit project.</p> <p>All Category 1 and 2 projects must comply with all of this GP's applicable terms (Pages 1 – 4) and General Conditions (Pages 5–20).</p>	<p>CATEGORY 2 (PCN Required)</p> <p>Replacement of non-serviceable fills, or repair/maintenance of serviceable fill, with expansion <3 acres, or with a change in use.</p>
<p>ACTIVITY</p> <p>CATEGORY 1 Self-Verification Eligible (SVNF Required)</p>	<p>Repair or maintenance of existing, currently serviceable, authorized fills with no expansion or change in use:</p> <ul style="list-style-type: none"> • Conditions of the original authorization apply. • Minor deviations in fill design allowed.⁷ • The repair, rehabilitation, or replacement of those structures or fills destroyed or damaged by storms, floods, fire or other discrete events is authorized, provided the repair, rehabilitation, or replacement is commenced, or is under contract to commence, within two years of the date of their destruction or damage. • No effect on federally listed endangered or threatened species or critical habitat. 	<p>CATEGORY 2 (PCN Required)</p> <p>Replacement of non-serviceable fills, or repair/maintenance of serviceable fill, with expansion <3 acres, or with a change in use.</p>
<p>1. Repair, Replacement, and Expansion of Maintenance of Authorized Structures and Fills</p>	<p>NA – moorings in non-navigable inland waters are not subject to Corps jurisdiction.</p> <p>Note: Moorings placed in freshwater navigable waters are reviewed in the Navigable Waters section. (See B. Navigable Waters on Page 28 below.)</p> <p>For solid fill or crib supported structures on inland waters, <15,000 square feet (SF) of waterway and/or wetland fill, associated secondary impacts², and temporary fills.</p> <ul style="list-style-type: none"> • No effect on federally listed endangered or threatened species or critical habitat. • Note: Temporary or permanent structures placed in freshwater navigable waters are reviewed in the Navigable Waters section. (See B. Navigable Waters on page 29 below.) 	<p>NA</p>
<p>2. Moorings</p>	<p>NA – moorings in non-navigable inland waters are not subject to Corps jurisdiction.</p> <p>Note: Moorings placed in freshwater navigable waters are reviewed in the Navigable Waters section. (See B. Navigable Waters on Page 28 below.)</p> <p>For solid fill or crib supported structures on inland waters, <15,000 square feet (SF) of waterway and/or wetland fill, associated secondary impacts², and temporary fills.</p> <ul style="list-style-type: none"> • No effect on federally listed endangered or threatened species or critical habitat. • Note: Temporary or permanent structures placed in freshwater navigable waters are reviewed in the Navigable Waters section. (See B. Navigable Waters on page 29 below.) 	<p>1. Work not eligible for Category 1</p> <p>2. ≥15,000 SF to <3 acres of inland waterway and/or wetland fill and associated secondary impacts (e.g., areas drained, flooded, fragmented, or excavated).</p>
<p>3. Structures, Floats & Lifts</p>	<p>NA - this activity in non-navigable inland waters is not subject to Corps jurisdiction.</p> <p>Note: Aids to Navigation and other structures placed in freshwater navigable waters are reviewed in the Navigable Waters section. (See B. Navigable Waters on page 30 below.)</p>	<p>NA</p>
<p>4. Aids to Navigation and Temporary Recreational Structures</p>	<p>NA - this activity in non-navigable inland waters is not subject to Corps jurisdiction.</p> <p>Note: Aids to Navigation and other structures placed in freshwater navigable waters are reviewed in the Navigable Waters section. (See B. Navigable Waters on page 30 below.)</p>	<p>NA</p>

<p>5. Dredging, Disposal of Dredged Material, Beach Nourishment, and Rock Removal and Relocation</p>	<p>1. For regulated discharges associated with excavation, and disposal <15,000 SF inland waterway and/or wetland impacts. 2. The activity does not occur in navigable waters of the U.S. 3. Stream channelization, relocation or loss of streambed including impoundments or discharge of tailings into streams does not occur. 4. No effect on federally listed endangered or threatened species or critical habitat.</p>	<p>1. Work not eligible for Category 1 2. ≥15,000 SF to <3 acres of inland waters.</p>
<p>6. Discharges of Dredged or Fill Material Incidental to the Construction of Bridges</p>	<p>NA - For discharges incidental to the construction of bridges in inland waters of the U.S. refer to Activity 23 (Stream and Wetland Crossings) and GC 45. Note: Discharges of Dredged or Fill Material Incidental to the Construction of Bridges in freshwater navigable waters are reviewed in the Navigable Waters section. (See B. Navigable Waters on page 30 below.)</p>	<p>NA</p>
<p>7. Bank and Shoreline Stabilization</p>	<p>Inland bank stabilization <500 FT long and ≤1 CY of fill per linear foot below OHW, provided:</p> <ul style="list-style-type: none"> • ≤1 cubic yard of fill per linear foot placed along the bank waterward of ordinary high water. • Work complies with the GCs (GC 44 in particular), including: <ul style="list-style-type: none"> ○ No structures angled steeper than 1H:1V allowed. Only rough-faced stone or fiber roll revetments allowed. ○ No in-stream work involving fill or excavation in flowing waters (see GC 45(h)). • In-water work limited to Jul 15 – Sep 30. • No work in vernal pools⁵ or SAS³. • No effect on federally listed endangered or threatened species or critical habitat. 	<p>Work not eligible for Category 1</p>
<p>8. Residential, Commercial, Industrial, and Institutional Developments, and Recreational Facilities</p>	<p>1. <15,000 SF of inland waterway and/or wetland fill and associated secondary impacts² (e.g., areas drained, flooded, fragmented, mechanically cleared or excavated). Fill area includes all temporary and permanent fill, and regulated discharges associated with excavation. Construction mats are considered as fill. [See GC 14] <u>Provided:</u></p> <ul style="list-style-type: none"> • Historic fill + proposed impact area <15,000 SF complies with GC 5, Single and Complete Projects. • No work in special aquatic sites (SAS)⁴ other than wetlands. • No effect on federally listed endangered or threatened species or critical habitat. <p>2. For work in Vernal Pool (VP) Management Areas (includes VPs)⁵:</p> <ul style="list-style-type: none"> • See GC 23 and Appendix C for VP delineation requirements. 	<p>1. Work not eligible for Category 1. 2. ≥15,000 SF to <3 acres of inland waterway and/or wetland fill and associated secondary impacts (e.g., areas drained, flooded, fragmented, or excavated). Fill area includes all temporary and permanent fill (including mats), and regulated discharges associated with excavation. 3. <i>Mechanical clearing without grubbing or other soil disturbance >3 acres as a secondary impact may still be eligible for Category 2 at the discretion of the Corps.</i></p> <p>See GC 2 and Appendix C for wetland delineation requirements.</p>

<p>9. Utility Line Activities</p>	<ul style="list-style-type: none"> • See GC 23 to determine if work qualifies for Category 1 or 2. • See Appendix G for VP documents providing mitigation guidance. 	<p>1. Work not eligible for Category 1</p> <p>2. $\geq 15,000$ SF to < 3 acres of inland waterway and/or wetland fill and associated secondary impacts (e.g., areas drained, flooded, fragmented, or excavated). Fill area includes all temporary and permanent fill (including mats), and regulated discharges associated with excavation.</p> <p>3. <i>Mechanical clearing without grubbing or other soil disturbance</i> > 3 acres as a secondary impact may still be eligible for Category 2 at the discretion of the Corps.</p>
<p>10. Linear Transportation Projects (not including stream crossings)</p> <p>For stream crossings, refer to Activity 23</p>	<ol style="list-style-type: none"> 1. $< 15,000$ SF of inland waterway and/or wetland fill, associated secondary impacts², and temporary fills. 2. The activity does not occur in, over, or under navigable waters of the U.S. 3. Intake structures that are dry hydrants used exclusively for firefighting activities with no stream impoundments. 4. There is no permanent change in pre-construction contours in waters of the U.S. 5. Material resulting from trench excavation is temporarily side cast into waters of the U.S. for ≤ 3 months and is placed in such a manner that it is not dispersed by currents or other forces. 6. The utility line is placed within and does not run a) parallel to, or b) along a streambed. 7. Stream channelization, relocation or loss of streambed including impoundments does not occur. 8. No effect on federally listed endangered or threatened species or critical habitat. 9. There is no discharge in SAS other than non-tidal wetlands. 10. Construction mats⁴ of any area necessary to conduct activities that were previously authorized, authorized under Category 1, or not subject to regulation (see Endnote 7). Authorized construction mats must be in place for < 3 months, removed immediately upon work completion, and the wetlands must be restored (see GC 43). 11. Stream crossings must comply with GC 17. 	<ol style="list-style-type: none"> 1. $\geq 15,000$ SF to < 3 acres of inland waterway and/or wetland fill and associated secondary impacts (e.g., areas drained, flooded, fragmented, or excavated). Fill area includes all temporary and permanent fill (including mats), and regulated discharges associated with excavation. 2. <i>Mechanical clearing without grubbing or other soil disturbance</i> > 3 acres as a secondary impact may still be eligible for Category 2 at the discretion of the Corps.

<p>11. Mining Activities</p>	<p>1. <15,000 SF of inland waterway and/or wetland fill, associated secondary impacts, and temporary impacts. 2. The activity does not occur in navigable waters of the U.S. 3. Stream channelization, relocation or loss of streambed including impoundments or discharge of failings into streams does not occur. 4. No effect on federally listed endangered or threatened species or critical habitat.</p>	<p>1. Work not eligible for Category 1. 2. ≥15,000 SF to <3 acres of inland waterway and/or wetland fill and associated secondary impacts (e.g., areas drained, flooded, fragmented, or excavated). Fill area includes all temporary and permanent fill (including mats), and regulated discharges associated with excavation.</p>
<p>12. Boat Ramps</p>	<p>1. <15,000 SF of inland waterway and/or wetland fill, associated secondary impacts, and temporary impacts. 2. No effect on federally listed endangered or threatened species or critical habitat.</p>	<p>1. Work not eligible for Category 1 2. >15,000 SF and < 3 acres of impact.</p>
<p>13. Land and Water-Based Renewable Energy Generation Facilities and Hydropower Projects</p>	<p><i>For land-based facilities:</i> 1. <15,000 SF of inland waterway and/or wetland fill, associated secondary impacts, and temporary impacts. 2. Stream channelization, relocation or loss of streambed including impoundments does not occur. 3. No effect on federally listed endangered or threatened species or critical habitat.</p> <p><i>For water-based facilities and hydropower projects:</i> No new facilities are eligible.</p>	<p><i>For land-based activities:</i> 1. Work not eligible for Category 1. 2. >15,000 SF and < 3 acres impact. 3. <i>Mechanical clearing without grubbing or other soil disturbance >3 acres as a secondary impact may still be eligible for Category 2 at the discretion of the Corps.</i></p> <p><i>For water-based facilities and hydropower projects:</i> > 3 acres of impact will require an IP.</p>
<p>14. Reshaping Existing Drainage Ditches & Mosquito Management</p>	<p>Not Applicable</p>	<p>Not Applicable</p>
<p>15. Oil Spill and Hazardous Material Cleanup</p>	<p>Jurisdictional activities required for the containment and cleanup of oil and hazardous substances that are subject to the National Oil and Hazardous Substances Pollution Contingency Plan (40 CFR 300) provided that the work is done in accordance with the Spill Control and Countermeasure Plan required by 40 CFR 112.3 or any existing state contingency plan and provided that the Regional Response Team (if one exists in the area) concurs with the proposed containment and cleanup action. SAS³ must typically be restored in place at the same elevation. <i>Note: SVN/F or a surrogate state reporting form may be submitted after the fact.</i></p>	<p>Work not eligible for Category 1</p>

<p>16. Cleanup of Hazardous and toxic waste</p>	<p>Specific jurisdictional activities to effect the containment, stabilization, or removal of hazardous or toxic waste materials, including court ordered remedial action plans or related settlements, which are performed, ordered or sponsored by a government agency with established legal or regulatory authority. SAS should be restored in place at the same elevation.</p> <ul style="list-style-type: none"> • <15,000 SF of inland waterway and/or wetland fill, associated secondary impacts, and temporary impacts. • No stream channelization, relocation or loss of streambed occurs. • The project does not involve establishing new disposal sites or expanding existing sites used for the disposal of hazardous or toxic waste. • No effect on federally listed endangered or threatened species or critical habitat. 	<p>Work not eligible for Category 1</p>
<p>17. Scientific Measurements Devices</p>	<ol style="list-style-type: none"> 1. Scientific measurement devices whose purpose is to measure and record scientific data, such as staff gages, water recording devices, water quality testing and improvement devices, and similar structures. This excludes any biological sampling devices. Structures may not restrict or concentrate movement of aquatic organisms. 2. No effect on federally listed endangered or threatened species or critical habitat. 	<p>Work not eligible for Category 1</p>
<p>18. Survey Activities</p>	<ol style="list-style-type: none"> 1. Jurisdictional survey activities, such as core sampling, seismic exploratory operations, plugging of seismic shot holes and other exploratory-type bore holes, exploratory trenching, soil surveys, sampling, and historic resources surveys (but not recovery). Exploratory trenches must be restored in accordance with GC 43. The construction of temporary pads is authorized provided the discharge doesn't exceed 25 CY. This doesn't authorize permanent structures or the drilling and the discharge of excavated material from test wells for oil and gas exploration (the plugging of such wells is authorized). 2. No effect on federally listed endangered or threatened species or critical habitat. 	<p>Work not eligible for Category 1</p>
<p>19. Agricultural Activities</p>	<ol style="list-style-type: none"> 1. For those activities subject to Corps jurisdiction¹⁶, <15,000 SF of inland waterway and/or wetland fill, associated secondary impacts, and temporary impacts. 2. No stream channelization, relocation, loss of streambed, or farm ponds in streams. 3. No effect on federally listed endangered or threatened species or critical habitat. 	<ol style="list-style-type: none"> 1. ≥15,000 SF to <3 acres of inland waterway and/or wetland fill and associated secondary impacts (e.g., areas drained, flooded, fragmented, or excavated). Fill area includes all temporary and permanent fill (including mats), and regulated discharges associated with excavation. 2. > 3 acres of impact will require an IP.

<p>20. Fish and Wildlife Harvesting, Enhancement and Attraction Devices and Activities</p>	<p>NA - this activity in non-navigable inland waters, if not involving a discharge of dredged or fill material, is not subject to Corps jurisdiction. Note: Related structures placed in freshwater navigable waters (e.g. the upper Penobscot or Kennebec Rivers) are reviewed in the Navigable Waters section. (See B. Navigable Waters on Page 33 below.)</p>	<p>Not Applicable</p>
<p>21. Habitat Restoration, Establishment and Enhancement Activities</p>	<p>1. <15,000 SF of inland waterway and/or wetland fill, associated secondary impacts, and temporary impacts. 2. The activity is supported in writing by a local, state, or non-Corps Federal environmental agency. Water impoundments require PCN. 3. No conversion of i) a stream to wetland or vice versa, wetland to a pond or uplands, and ii) one wetland type to another. 4. No dam removal. 5. No effect on federally listed endangered or threatened species or critical habitat.</p>	<p>1. Work not eligible for Category 1 2. Aquatic habitat restoration, establishment, and enhancement of wetlands and riparian areas and the restoration and enhancement of streams and other open waters with impacts of any area \geq15,000 SF, provided those activities result in net increase in overall aquatic resource functions and services.⁸</p>
<p>22. Previously Authorized Activities</p>	<p>Any work not commenced nor completed that was authorized in a written letter from the Corps under the GP in effect between October 12, 2010 and October 12, 2015. The terms and general conditions of this GP apply along with any special conditions in the written authorization.</p>	
<p>23. Stream & Wetland Crossings</p>	<p>1. River, stream and brook work and crossings: <ul style="list-style-type: none"> • Must comply with GC 45 in particular, including: <ul style="list-style-type: none"> o No slip lining [see GC 45 (g)]. o No in-stream work involving fill or excavation in flowing waters [see GC 45(h)]. o In-stream work limited to Jul 15 – Sep 30 [see GC 45 (I)]. • No work in riffles and pools³. • No stream relocations. • No dams or dikes⁶. • No effect on federally listed endangered or threatened species or critical habitat. • <15,000 SF of inland waterway and/or wetland fill, associated secondary impacts, and temporary impacts. 2. Wetland crossings must comply with the particularly relevant GC 45.</p>	<p>Work not eligible for Category 1</p>
<p>24. Aquaculture (freshwater)</p>	<p>For land based installations, <15,000 SF of inland waterway and/or wetland fill, associated secondary impacts, and temporary impacts. <ul style="list-style-type: none"> • In-stream/in-water work limited to Jul 15 – Sep 30. • No effect on federally listed endangered or threatened species or critical habitat. Note: Related structures placed in freshwater navigable waters are reviewed in the Navigable Waters section. (See B. Navigable Waters, below.)</p>	<p>Work not eligible for Category 1</p>

B. NAVIGABLE WATERS

Navigable Waters of the United States: Waters that are subject to the ebb and flow of the tide and/or the tidal and non-tidal portions of the Federally designated navigable waters (the Penobscot River, Kennebec River, and Lake Umbagog) (Section 10 Rivers and Harbors Act of 1899). The jurisdictional limits are the mean high water (MHW) line in tidal waters and the ordinary high water (OHW) mark in non-tidal portions of the federally designated navigable rivers. For the purposes of this GP, fill placed in the area between the mean high water (MHW) and the high tide line (HTL), and in the bordering and contiguous wetlands¹ to tidal waters are also reviewed in this Navigable Waters section.

Projects not meeting Category 1 require an application for review as a Category 2 or Individual Permit project.

All Category 1 and 2 projects must comply with all of this GP's applicable terms (Pages 1 - 4) and General Conditions (Pages 5 - 20).

CATEGORY 1 Self-Verification Eligible (SVNF Required)

1. Repair, Replacement, and Expansion of Authorized (or grandfathered) Structures and Fills

1. Repair, replacement in-kind, or maintenance⁷ of existing, currently serviceable⁷, authorized structures or fills:

- All work is to be conducted in-the-dry, during low water.
- Conditions of the original authorization apply.
- No substantial expansion or change in use.
- No new fill in SAS³.
- Must be rebuilt in same footprint, however minor deviations in structure design allowed⁷.
- The repair, rehabilitation, or replacement of those structures or fills destroyed or damaged by storms, floods, fire or other discrete events is authorized, provided the repair, rehabilitation, or replacement is commenced, or is under contract to commence, within two years of the date of their destruction or damage.

CATEGORY 2 (PCN Required)

1. Replacement of non-serviceable structures and fills or repair/maintenance of serviceable structures or fills, with fill, replacement or expansion <1 acre, or with a change in use.

2. <1 acre temporary or permanent fill, excavation and/or secondary impacts. Fill area includes all temporary and permanent waterway fills, provided:

- Temporary or permanent fill in eelgrass¹⁴ <1000 SF.
- Permanent fill in SAS (excluding eelgrass¹⁴) <4300 SF.

3. Standard Pile Driving Conditions. Work involving piles shall adhere to one of the four methods below:

- Piles installed in-the-dry during low water or in-water between Nov. 8th - Apr. 9th, or
- Must be drilled and pinned to ledge, or
- Vibratory hammers used to install any size and quantity of wood, concrete or steel piles, or
- Impact hammers limited to one hammer and <50 piles installed/day with the following: wood piles of any size, concrete piles ≤18-inches diameter, steel piles <12-inches diameter if the hammer is ≤3000 lbs and a wood cushion is used between the hammer and steel pile, and

For the methods above:

- In-water noise levels shall not exceed >187dB cSEL re 1μPa or 206dB peak re 1μPa at a distance >10m from the pile being installed, and
- In-water noise levels >150dB peak re 1μPa shall not exceed 12 consecutive hours on any given day and a 12 hour recovery period (i.e., in-water noise below 150dB peak re 1μPa) must be provided between work days.
- Existing derelict, degraded or abandoned piles in the project area that are affected by project activities should be removed and properly disposed of in an upland location landward of MHW or OHW and not in wetlands, tidal wetlands, their substrate or inudflats.

<p>2. Moorings</p>	<p>1. Private, non-commercial, non-rental, single-boat moorings, provided:</p> <ul style="list-style-type: none"> • Authorized by the local harbormaster/town. • Not associated with any boating facility.¹¹ • Boat or mooring not located in a Federal Navigation Project or buffer zone¹² other than in a Federal Anchorage¹². Moorings in a Federal Anchorage not associated with a boating facility¹¹ and are not for rent. • No interference with navigation. • No new moorings located in SAS³. Prior to installation of moorings, a site-specific eelgrass survey should be conducted to document that eelgrass is not present. • When existing, authorized moorings in SAS³ are going to be replaced, they should be replaced with low impact mooring technology that prevents mooring chains from resting or dragging on the bottom substrate at all tides and helical anchors, or equivalent SAS protection systems where practicable. <p>2. Minor relocation of previously authorized moorings, provided:</p> <ul style="list-style-type: none"> • Authorized by the local harbormaster/town. • Not located in SAS³ • No interference with navigation. • Cannot be relocated into a Federal Navigation Project¹² other than a Federal Anchorage¹² <p>Note: Cat I eligible moorings do not require SYNFF.</p>	<p>1. Moorings associated with an existing boating facility¹¹. An eelgrass¹⁴ survey may be required.</p> <p>2. Moorings that don't meet the terms in Category 1 and don't require an Individual Permit. This includes private moorings with no harbormaster or means of local approval.</p> <p>3. Moorings located such that they, and/or vessels docked or moored at them, are within the buffer zone of the horizontal limits¹³ of a Federal Channel¹². (See Appendix H.) The buffer zone is equal to 3 times the authorized depth of that channel.</p> <p>4. An IP is required for moorings within the horizontal limits¹¹, or with moored vessels that extend, into the horizontal limits of a Federal Navigation Project¹², except those in Federal Anchorages¹².</p> <p><i>For 1-4 above, siting of new individual moorings in SAS³, including eelgrass¹⁴, should be avoided to the maximum extent practicable. If SAS³ cannot be avoided, plans should show elastic mooring systems that prevent mooring chains from resting or dragging on the bottom substrate at all tides and helical anchors, or equivalent SAS protection systems, where practicable. For moorings that appear to impact SAS, the Corps may require an eelgrass survey.</i></p>
<p>3. Structures, Floats and Lifts</p>	<p>1. Reconfiguration of existing authorized structures shall occur in-the-dry during low water.</p> <p>2. Minor relocation of previously authorized floats or moored floats/lobster cars, provided:</p> <ul style="list-style-type: none"> • Authorized by the local harbormaster/town. • Not located in SAS³. • No interference with navigation. • Cannot be relocated into a Federal Navigation Project¹² other than a Federal Anchorage¹². 	<p>1. New structures or floats, including floatways/skidways, built to access waterway (seasonal and permanent). Includes both pile supported and crib supported structures.</p> <p>2. Expansions to existing boating facilities¹¹</p> <ul style="list-style-type: none"> • <i>Pile-supported structures <400 SF, with attached floats totaling ≤200 SF.</i> • <i>Bottom anchored floats ≤200 SF.</i> • <i>Structures are ≤4' wide and have at least a 1:1 height:width ratio¹¹.</i> • <i>Floats supported a minimum of 18" above the substrate during all tides.</i> • <i>Structures & floats not located within 25' of any eelgrass⁸.</i> • <i>Moored vessels not positioned over SAS³.</i> • <i>The Corps may require a letter of no objection from the abutter if</i>

structure is to be within 25 feet of the property line.

- No structure extends across > 25% of the waterway width at mean low water.
 - Not located within the buffer zone of the horizontal limits¹³ of a Corps Federal Navigation Project (FNP) (App. F). The buffer zone is equal to three times the authorized depth of that FNP.
3. An Individual Permit is required for structures or floats, including floatways/skidways, located such that they and/or vessels docked or moored at them are within the horizontal limits¹³ of a Corps Federal Navigation Project¹² (see App. H).
4. An Individual Permit is required for structures & floats associated with a new or previously unauthorized boating facility¹¹.
5. Standard Pile Driving Conditions. Work involving piles shall adhere to one of the four methods below:
- Piles installed in-the-dry during low water or in-water between Nov. 8th - Apr. 9th, or
 - Must be drilled and pinned to ledge, or
 - Vibratory hammers used to install any size and quantity of wood, concrete or steel piles, or
 - Impact hammers limited to one hammer and <50 piles installed/day with the following: wood piles of any size, concrete piles ≤18-inches diameter, steel piles <12-inches diameter if the hammer is ≤3000 lbs and a wood cushion is used between the hammer and steel pile, and
 - For the methods above:
 - In-water noise levels shall not exceed >187dB cSEL re 1μPa or 206dB peak re 1μPa at a distance >10m from the pile being installed, and
 - In-water noise levels >150dB peak re 1μPa shall not exceed 12 consecutive hours on any given day and a 12 hour recovery period (i.e., in-water noise below 150dB peak re 1μPa) must be provided between work days.
 - Existing derelict, degraded or abandoned piles in the project area that are affected by project activities should be removed and properly disposed of in an upland location landward of MHW or OHW and not in wetlands, tidal wetlands, their substrate or mudflats.

<p>4. Aids to Navigation and Temporary Recreational Structures</p>	<p>1. Temporary buoys, markers, floats, etc. for recreational use during specific events, provided they are removed within 30 days after use is discontinued.</p> <p>2. The placement of aids to navigation and regulatory markers which are approved by and installed in accordance with the requirements of the U.S. Coast Guard. (See 33 CFR 66, Chapter I, subchapter C). <i>Note: Cat 1 eligible aids to navigation and regulatory markers do not require SVNF.</i></p>	<p>Work not eligible for Category 1</p>
<p>5. Dredging, Disposal of Dredged Material, Beach Nourishment, and Rock Removal and Relocation</p>	<p>1. Maintenance dredging¹⁰ for navigational purposes <1,000 CY with upland disposal. Includes return water from upland contained disposal area, provided:</p> <ul style="list-style-type: none"> • Proper siltation controls are used. • Dredging & disposal operation limited to Nov. 8 – Apr. 9. • No impact to SAS³. • No dredging in intertidal areas. • No dredging within 100' of shellfish beds. • No dredging in areas designated as Critical Habitat for Atlantic salmon [see GC 8(b) & (c)]. • For dredging in tidal waters outside of Atlantic salmon critical habitat, applicants must contact NMFS (see GC 8) to ensure no impacts to listed species such as shortnose sturgeon, Atlantic sururgeon, and listed sturgeon critical habitat. • Project proponents must contact the USFWS for work on coastal beaches to ensure no impacts to piping plovers, roseate terns, rufa red knot, or their habitat [see GC 8(c)]. • No underwater blasting. <p>2. Maintenance dredging is not eligible for Category 1 if conducted in tidal portions of the Penobscot river upstream of a line extending from Turner point in Castine to Moose Point (formerly Squaw Point) on Cape Jellison in Stockton Springs or in tidal portions of the Kennebec or Androscoggin Rivers upstream of a line extending from Doubling point in Arrowsic to Hospital Point in West Bath.</p>	<p>1. Maintenance dredging¹⁰ ≥1,000 CY, new dredging <25,000 CY, or projects not meeting Category 1. Includes return water from upland contained disposal areas. Disposal includes:</p> <ul style="list-style-type: none"> • Upland. • Beach nourishment (above mean high water) of any area provided the dredging's primary purpose is navigation or the sand is from an upland source. • Open water & confined aquatic disposal, if Corps finds the material suitable. <p>2. Beach nourishment associated with dredging when the primary purpose is not navigation requires at least a Category 2 review.</p> <p>3. Maintenance or new dredging¹⁰ and/or disposal in or affecting a SAS³ requires an Individual Permit.</p>

<p>6. Discharges of Dredged or Fill Material Incidental to the Construction of Bridges</p>	<p>1. Discharges of dredged or fill material incidental to the construction of bridges across navigable waters of the U.S., including cofferdams, abutments, foundation seals, piers, and temporary construction and access fills provided the U.S. Coast Guard authorizes such discharges as part of the bridge permit or appropriate approval. 2. Causeways and approach fills are not included in this category and require Category 2 or Individual Permit authorization.</p>	<p><1 acre temporary or permanent fill, excavation and/or secondary impacts (e.g., areas drained, flooded, fragmented or mechanically cleared). Fill area includes all temporary and permanent waterway fills, provided:</p> <ul style="list-style-type: none"> • Temporary or permanent fill in eelgrass¹⁴ <1000 SF. • Permanent fill in SAS (excluding eelgrass¹⁴) <4300 SF.
<p>7. Bank and Shoreline Stabilization</p>	<p>1. Bank stabilization projects <200 linear feet provided:</p> <ul style="list-style-type: none"> • ≤1 cubic yard of fill per linear foot placed along the bank waterward of high tide line. No fill or equipment will occur in SAS³. • Work conducted in the intertidal zone must be conducted in-the-dry during low water. • No structures angled steeper than 1H:1V and only rough-faced stone or fiber roll revetments allowed. • No driving of piles or sheeting. <p>2. Bank stabilization projects in excess of 200 linear feet (Applicant or Applicant + Abutters combined) must undergo Category 2 review.</p>	<p>1. Work not eligible for Category 1. 2. <1 acre temporary or permanent fill, excavation and/or secondary impacts (e.g., areas drained, flooded, fragmented or mechanically cleared). Fill area includes all temporary and permanent waterway fills, provided:</p> <ul style="list-style-type: none"> • Temporary or permanent fill in eelgrass¹⁴ <1000 SF. • Permanent fill in SAS (excluding eelgrass¹⁴) <4300 SF.
<p>8. Residential, Commercial, Industrial, and Institutional Developments, and Recreational Facilities</p>	<p>Not Eligible</p>	<p>1. <1 acre temporary or permanent fill, excavation and/or secondary impacts (e.g., areas drained, flooded, fragmented or mechanically cleared). Fill area includes all temporary and permanent waterway fills, provided:</p> <ul style="list-style-type: none"> • Temporary or permanent fill in eelgrass¹⁴ <1000 SF. • Permanent fill in SAS (excluding eelgrass¹⁴) <4300 SF. <p>2. Conversions of previously authorized pile supported buildings over navigable waters to residences, offices, or other non-water dependent uses require at least a Category 2 review. 3. Floating house boats or businesses on floats require Category 2 review.</p>
<p>9. Utility Line Activities</p>	<p>1. Repair or maintenance of existing, currently serviceable, authorized utilities with no expansion or change in use:</p> <ul style="list-style-type: none"> • Conditions of the original authorization apply. • Trenching or filling is confined to the existing footprint. • In water work conducted between Nov 8 and Apr 9. • No new impact to SAS. <p>3. <u>New work</u> in, over, or under navigable waters requires a PCN and Category 2 review. 4. Except for aerial utility lines, work is not eligible for Category 1 if</p>	<p>1. New or replacement installations or work not otherwise eligible for Category 1. 2. <1 acre temporary or permanent fill, excavation and/or secondary impacts (e.g., areas drained, flooded, fragmented or mechanically cleared). Fill area includes all temporary and permanent waterway fills, provided:</p> <ul style="list-style-type: none"> • Temporary or permanent fill in eelgrass¹⁴ <1000 SF. • Permanent fill in SAS (excluding eelgrass¹⁴) <4300 SF. <p>3. Particularly relevant is GC12</p>

	conducted in tidal portions of the Penobscot river upstream of a line extending from Turner point in Castine to Moose Point (formerly Squaw Point) on Cape Jellison in Stockton Springs or in tidal portions of the Kennebec or Androscoggin Rivers upstream of a line extending from Doubling point in Arrowsic to Hospital Point in West Bath.	
10. Linear Transportation Projects (Not Including Stream Crossings)	Not eligible	<1 acre temporary or permanent fill, excavation and/or secondary impacts (e.g., areas drained, flooded, fragmented or mechanically cleared). Fill area includes all temporary and permanent waterway fills, provided: <ul style="list-style-type: none"> • Temporary or permanent fill in eelgrass¹⁴ <1000 SF. • Permanent fill in SAS (excluding eelgrass¹⁴) <4300 SF.
11. Mining Activities	Not Eligible	Not Eligible
12. Boat Ramps and Marine Railways	<ol style="list-style-type: none"> 1. No new impact to SAS 2. Marine railway and boat ramp work not eligible for maintenance⁷ (i.e. not currently serviceable⁷) may be replaced "in-kind" with minor deviations⁷ provided: <ul style="list-style-type: none"> • Work is in the intertidal zone. • No fill expansion below high tide line. • Work conducted in-the-dry during low water. 3. No new boat ramps or marine railways. 	<ol style="list-style-type: none"> 1. Work not eligible for Category 1 2. <1 acre temporary or permanent fill, excavation and/or secondary impacts (e.g., areas drained, flooded, fragmented or mechanically cleared). Fill area includes all temporary and permanent waterway fills, provided: <ul style="list-style-type: none"> • Temporary or permanent fill in eelgrass¹⁴ <1000 SF. • Permanent fill in SAS (excluding eelgrass¹⁴) <4300 SF.
13. Land and Water-Based Renewable Energy Generation Facilities and Hydropower Projects	Not Eligible	<ol style="list-style-type: none"> 1. <1 acre temporary or permanent fill, excavation and/or secondary impacts (e.g., areas drained, flooded, fragmented or mechanically cleared). Fill area includes all temporary and permanent waterway fills, provided: <ul style="list-style-type: none"> • Temporary or permanent fill in eelgrass¹⁴ <1000 SF. • Permanent fill in SAS (excluding eelgrass¹⁴) <4300 SF. 2. No new impoundments.
14. Reshaping Existing Drainage Ditches and Mosquito Management	<ol style="list-style-type: none"> 1. ≤500 linear feet of drainage ditch will be modified. The reshaping of the ditch cannot increase drainage capacity beyond the original as-built capacity nor can it expand the area drained by the ditch as originally constructed (i.e., the capacity of the ditch must be the same as originally constructed and it cannot drain additional wetlands or other waters of the U.S.). 2. No new ditches or relocation of drainage ditches constructed in waters of the U.S.; the location of the centerline of the reshaped drainage ditch must be approximately the same as the location of the centerline of the original drainage ditch. 	<ol style="list-style-type: none"> 1. Work not eligible for Category 1 2. <1 acre temporary or permanent fill, excavation and/or secondary impacts (e.g., areas drained, flooded, fragmented or mechanically cleared). Fill area includes all temporary and permanent waterway fills, provided: <ul style="list-style-type: none"> • Temporary or permanent fill in eelgrass¹⁴ <1000 SF. • Permanent fill in SAS (excluding eelgrass¹⁴) <4300 SF.

	3. No effect on federally listed endangered or threatened species or critical habitat	Work not eligible for Category 1
15. Oil Spill and Hazardous Material Cleanup	Jurisdictional activities required for the containment and cleanup of oil and hazardous substances that are subject to the National Oil and Hazardous Substances Pollution Contingency Plan (40 CFR 300) provided that the work is done in accordance with the Spill Control and Countermeasure Plan required by 40 CFR 112.3 and any existing state contingency plan and provided that the Regional Response Team (if one exists in the area) concurs with the proposed containment and cleanup action. SAS ³ must typically be restored in place at the same elevation. <i>Note: SVN^F or a surrogate state reporting form may be submitted after the fact. No SVN^F is required for Category 1 eligible containment booms.</i>	Specific jurisdictional activities with impacts of any area required to affect the containment, stabilization, or removal of hazardous or toxic waste materials that are performed, ordered, or sponsored by a government agency with established legal or regulatory authority. Wetlands and other SAS must typically be restored in place at the same elevation to qualify.
16. Cleanup of Hazardous and Toxic Waste	Not eligible - except for booms placed for hazardous and toxic waste containment and absorption and prevention which are eligible for SV. <i>Note: No SVN^F is required for Category 1 eligible containment booms.</i>	1. Work not eligible for Category 1 2. <1 acre temporary or permanent fill, excavation and/or secondary impacts (e.g., areas drained, flooded, fragmented or mechanically cleared). Fill area includes all temporary and permanent waterway fills, provided: • Temporary or permanent fill in eelgrass ¹⁴ <1000 SF. • Permanent fill in SAS (excluding eelgrass ¹⁴) <4300 SF.
17. Scientific Measurement Devices	Scientific measurement devices whose purpose is to measure and record scientific data, such as staff gages, water recording devices, water quality testing and improvement devices, and similar structures. Structures may not restrict or concentrate movement of aquatic organisms; no activity results in a hazard to navigation; and no activity requiring underwater blasting.	1. Work not eligible for Category 1 2. <1 acre temporary or permanent fill, excavation and/or secondary impacts (e.g., areas drained, flooded, fragmented or mechanically cleared). Fill area includes all temporary and permanent waterway fills, provided: • Temporary or permanent fill in eelgrass ¹⁴ <1000 SF. • Permanent fill in SAS (excluding eelgrass ¹⁴) <4300 SF.
18. Survey Activities	Jurisdictional survey activities such as exploratory drilling, surveying and sampling activities, excluding any biological sampling devices. Does not include any activity requiring underwater blasting, seismic exploratory operations, or oil and gas exploration and fill for roads or construction pads. No activity may result in a hazard to navigation.	1. Work not eligible for Category 1 2. <1 acre temporary or permanent fill, excavation and/or secondary impacts (e.g., areas drained, flooded, fragmented or mechanically cleared). Fill area includes all temporary and permanent waterway fills, provided: • Temporary or permanent fill in eelgrass ¹⁴ <1000 SF. • Permanent fill in SAS (excluding eelgrass ¹⁴) <4300 SF.
19. Agricultural Activities	Not Eligible	Not Eligible

<p>20. Fish & Wildlife Harvesting, Enhancement and Attraction Devices and Activities (Not Aquaculture)</p>	<p>Fish and wildlife harvesting, enhancement, and attraction devices and activities such as pound nets, crab traps, crab dredging, eel pots, lobster traps, and clam and oyster digging, and small fish attraction devices such as open water fish concentrators (sea kites, etc.). This does not authorize artificial reefs or impoundments and semi-impoundments of waters of the U.S. for the culture or holding of motile species such as lobster, or the use of covered oyster trays or clam racks. No activity that may result in a hazard to navigation. <i>Note: A SVNF is not required for these Category 1 eligible devices and activities.</i></p>	<p>1. Work not eligible for Category 1. 2. Impoundments or semi-impoundments of waters of the U.S. for the culture or holding of motile species such as lobster and new fish weirs with an impounded area \leq 1/2 acre. For Aquaculture operations, refer to Activity 24.</p>
<p>21. Habitat Restoration, Establishment and Enhancement Activities</p>	<p>1. Culch placement in tidal waters is eligible for SV provided there are no salt marsh or vegetated shallow impacts. 2. SAS planting and transplanting \leq 100 SF in tidal waters; 3. No artificial or living reefs. 4. The activity is authorized in writing by a local, state, or non-Corps federal environmental agency. Water impoundments require PCN. 5. No conversion of i) a stream to wetland or vice versa, wetland to a pond or uplands, and ii) one wetland type to another. 6. No dam removal. 7. Shellfish habitat enhancement such as brushing the flats is eligible for Category 1, but not the use of netting which requires Category 2 review.</p>	<p>1. Work not eligible for Category 1. 2. Aquatic habitat restoration, establishment and enhancement provided those activities are proactive and result in net increases in aquatic resource functions and services.⁸</p>
<p>22. Previously Authorized Activities</p>	<p>Any work not commenced nor completed that was authorized in a written letter from the Corps under the GP in effect between October 12, 2010 and October 12, 2015. The terms and general conditions of this GP apply along with any special conditions in the written authorization.</p>	
<p>23. Stream & Wetland Crossings</p>	<p>Not Eligible</p>	<p>All temporary or permanent crossings of tidal navigable waters or adjacent tidal wetlands not eligible as maintenance require a PCN. GC 45 applies</p>
<p>24. Aquaculture</p>	<p>Not Eligible</p>	<p>Shellfish & finfish aquaculture (with the exception of Atlantic salmon and any other salmonid, or other federally listed endangered or threatened species), or other aquaculture facilities with no more than minimal individual and cumulative impacts to environmental resources or navigation. This is inclusive but not limited to cages, nets, bags, racks, long lines, fences, posts, poles, predator screening, etc. Aquaculture guidelines are provided at: www.maine.gov/dmr/aquaculture/index.htm.</p>

Endnotes/Definitions

¹**Bordering and Contiguous Wetlands:** A bordering wetland is immediately next to its adjacent waterbody and may lie at, or below, the ordinary high water mark (mean high water in navigable waters) of that waterbody and is directly influenced by its hydrologic regime. Contiguous wetlands extend landward from their adjacent waterbody to a point where a natural or manmade discontinuity exists. Contiguous wetlands include bordering wetlands as well as wetlands that are situated immediately above the ordinary high water mark and above the normal hydrologic influence of their adjacent waterbody. Note, with respect to the federally designated navigable rivers, the wetlands bordering and contiguous to the tidally influenced portions of those rivers are reviewed under "II. Navigable Waters."

² **Direct, Secondary, and Cumulative Impacts/Effects:**

Direct Impacts: The immediate loss of aquatic ecosystem within the footprint of the fill.

Secondary Impacts: These are effects on an aquatic ecosystem that are associated with a discharge of dredged or fill materials, but do not result from the actual placement of the dredged or fill material. Information about secondary effects on aquatic ecosystems shall be considered prior to the time final section 404 action is taken by permitting authorities. Some examples of secondary effects on an aquatic ecosystem are a) fluctuating water levels in all impoundment and downstream associated with the operation of a dam, b) septic tank leaching and surface runoff from residential or commercial developments on fill, and c) leachate and runoff from a sanitary landfill located in waters of the U.S. Put another way, secondary effects are those impacts outside the footprint of the fill that arise from and are associated with the discharge of dredged or fill material, including the operation of an activity or facility associated with the discharge. Examples may include habitat fragmentation; interruption of travel corridors for wildlife (for example, for amphibians that migrate to and from seasonal or vernal pools used as breeding habitat); hydrologic regime changes; and impacts from operation and maintenance activities for constructed facilities; such as noise/lighting, storm water runoff, and road kill of wetland dependent wildlife. Using the directions contained in the guidelines, we consider the circumstances of a proposed discharge and the project of which it is a part to evaluate the scope, extent, severity, and permanence of direct, secondary, and cumulative adverse effects upon the aquatic ecosystem.

Cumulative Impacts: The extent of past, present, and foreseeable developments in the area may be an important consideration in evaluating the significance of a particular project's impacts. Although the impacts associated with a particular discharge may be minor, the cumulative effect of numerous similar discharges can result in a large impact. Cumulative impacts should be estimated only to the extent that they are reasonable and practical.

³**Special Aquatic Sites:** Includes wetlands and saltmarsh, mudflats, riffles and pools, and vegetated shallows (predominantly comprised of eelgrass in Maine).

⁴**Construction Mats:** Constructions, swamp and timber mats (herein referred to as "construction mats") are generic terms used to describe structures that distribute equipment weight to prevent wetland damage while facilitating passage and providing work platforms for workers and equipment. They are comprised of sheets or mats made from a variety of materials in various sizes. A timber mat consists of large timbers bolted or cabled together. Corduroy roads, which are not considered to be construction mats, are cut trees and/or saplings with the crowns and branches removed, and the trunks lined up next to one another. Corduroy roads are typically installed as permanent structures. Like construction mats, they are considered as fill whether they're installed temporarily or permanently.

⁵**Vernal Pools:** A vernal pool, also referred to as a seasonal forest pool, is a temporary to semi-permanent body of water occurring in a shallow depression that typically fills during the spring or fall and may dry during the summer. Vernal pools have no permanent inlet or outlet and no viable populations of predatory fish. A vernal pool may provide the primary breeding habitat for wood frogs (*Rana sylvatica*), spotted salamanders (*Ambystoma maculatum*), blue-spotted salamanders (*Ambystoma laterale*), and fairy shrimp (*Eubranchipus* sp.), as well as valuable habitat for other plants and wildlife, including several rare, threatened, and endangered species. A vernal pool intentionally created for the purposes of compensatory mitigation is included in this definition. For the purposes of this GP, the presence of any of the following species in any life stage in any abundance level/quantity would designate the waterbody as a vernal pool: fairy shrimp, blue spotted salamanders, spotted salamanders or wood frogs. The Corps may determine during a Category 2 review that a waterbody should not be regulated as a VP based on available evidence. For the purposes of this GP, the VP Management Areas are the: Vernal Pool Depression (includes the vernal pool depression up to the spring or fall high water mark, and includes any vegetation growing within the depression), Vernal Pool Envelope (area within 100 FT of the VP Depression's edge) and Critical Terrestrial Habitat (area within 100-750 FT of the Vernal Pool Depression's edge). [*Note: Critical Terrestrial Habitat is defined as 100 -750 FT on page 243 of the document "Science and Conservation of Vernal Pools in Northeastern North America." Calhoun and deMaynadier, 2008, which is referenced in Appendix G, page 3, Paragraph 10(b).

⁶ **Water Diversions:** Water diversions are activities such as bypass pumping or water withdrawals. Temporary flume pipes, culverts or cofferdams where normal flows are maintained within the stream boundary's confines aren't water diversions. "Normal flows" are defined as no change in flow from pre-project conditions.

⁷ **Maintenance:** a) The repair, rehabilitation, or replacement of any previously authorized, currently serviceable structure or fill, or of any currently serviceable structure or fill authorized by 33 CFR 330.3 -- "Activities occurring before certain dates," provided that the structure or fill is not to be put to uses differing from those uses specified or contemplated for it in the original permit or the most recently authorized modification.

- Minor deviations in the structure's configuration or filled area, including those due to changes in materials, construction techniques, or current construction codes or safety standards that are necessary to make repair, rehabilitation, or replacement are authorized.
 - Currently serviceable means useable as is or with some maintenance, but not so degraded as to essentially require reconstruction.
 - No seaward expansion for bulkheads or any other fill activity is considered Category 1 maintenance.
 - Only structures or fills that were previously authorized and are in compliance with the terms and condition of the original authorization can be maintained as a non-regulated activity under 33 CFR 323.4(a)(2), or in accordance with the Category 1 or 2 thresholds in Appendix A.
- b) The state's maintenance provisions may differ from the Corps and may require reporting and written authorization from the state.
- c) Contact the Corps to determine whether stream crossing replacements require a written application to the Corps for at least a Category 2 review.
- d) Exempted Maintenance. In accordance with 33 CFR 323.4(a)(2), any discharge of dredged or fill material that may result from any of the following activities is not prohibited by or otherwise subject to regulation under Section 404 of the CWA: "Maintenance, including emergency reconstruction of recently damaged parts, of currently serviceable structures such as dikes, dams, levees, groins, riprap, breakwaters, causeways, bridge abutments or approaches, and transportation structures. Maintenance does not include any modification that changes the character, scope, or size of the original fill design."
- ⁸ **Aquatic Habitat Restoration, Establishment and Enhancement:** The Corps will decide if a project qualifies and must determine in consultation with federal and state agencies that the net effects are beneficial. The Corps may refer to Nationwide Permit 27 published in the 3/12/07 Federal Register. Activities authorized here may include, but are not limited to: the removal of accumulated sediments; the installation, removal, and maintenance of small water control structures, dikes, and berms; the installation of current deflectors; the enhancement, restoration, or establishment of riffle and pool stream structure; the placement of in-stream habitat structures; modifications of the stream bed and/or banks to restore or establish stream meanders; the backfilling of artificial channels and drainage ditches; the removal of existing drainage structures; the construction of small nesting islands in inland waters; the construction of open water areas; the construction of native shellfish species habitat over unvegetated bottom for the purpose of habitat protection or restoration in tidal waters; shellfish seeding; activities needed to reestablish vegetation, including plowing or discing for seed bed preparation and the planting of appropriate wetland species; mechanized land clearing to remove non-native invasive, exotic, or nuisance vegetation; and other related activities. Only native plant species should be planted at the site.
- ⁹ **Brushing the Flats:** The placement of tree boughs, wooden lath structure, or small-mesh fencing on mudflats to enhance recruitment of soft-shell clams (*Mya arenaria*).

¹⁰ **Maintenance Dredging:** This includes only those areas and depths previously authorized by the Corps and dredged. The Corps may require proof of authorization. Maintenance dredging typically refers to the routine removal of sediment to maintain the design depths of serviceable navigation channels, harbors, basins, marinas, boat launches, and port facilities. Maintenance dredging is conducted for navigational purposes and does not include any expansion of the previously dredged area or depth. The Corps may review a maintenance dredging activity as new dredging if sufficient time has elapsed to allow for the colonization of SAS, shellfish, etc.

¹¹ **Boating Facilities:** Facilities that provide for a fee, rent, or sell mooring space, such as marinas, yacht clubs, boat clubs, boat yards, town facilities, dockminiums, etc.

¹² **Federal Navigation Projects (FNPs):** FNPs are comprised of Federal Channels and Federal Anchorages. See Appendix F for their location and contact the Corps for more information. "Horizontal Limits" is the outer edge of an FNP. "Buffer Zone" is equal to three times the authorized depth of that channel.

¹³ **Horizontal Limits:** The outer edge of a Federal Navigation Project (FNP). See Appendix F and contact the Corps for information on FNP's.

¹⁴ **Eelgrass (*Zostera marina*):** A type of rooted aquatic vegetation that exists in intertidal and shallow subtidal areas known as vegetated shallows. See www.nepo.noaa.gov/hcd/ for eelgrass survey guidance. Note: Eelgrass surveys should be conducted between May and October unless otherwise directed.

¹⁵ **Structures:** The height of structures shall at all points be equal to or exceed the width of the deck. For the purpose of this definition, height shall be measured from the marsh substrate to the bottom of the longitudinal support beam.

¹⁶ **Agricultural Activities:** The Clean Water Act exempts certain discharges associated with normal farming, ranching, and forestry activities such as plowing, cultivating, minor drainage, and harvesting for the production of food, fiber, and forest products, or upland soil and water conservation practices (Section 404(f)(1)(A)). Applicants are strongly advised to contact the Corps for a determination of whether their activity is exempt or requires a permit.



Appendix B: Self-Verification Notification Form
(for all tidal and non-tidal projects in Maine subject to Corps jurisdiction)

**US Army Corps
of Engineers®**
New England District

At least two weeks before work commences, complete **all** fields (write "none" if applicable) below or use the fillable form at www.nae.usace.army.mil/missions/regulatory.aspx. Send this form, a location map, any project plans, and an Official Species List (See GC 8) to the address noted below; fax to (207) 623-8206; or email to jay.l.clement@usace.army.mil. The two-week lead time is not required for emergency situations (see page 4 for definition). Please call (207) 623-8367 with questions.

Maine Project Office
U.S. Army Corps of Engineers
New England District
675 Western Avenue #3
Manchester, Maine 04351

State Permit Number: _____
Date of State Permit: _____
State Project Manager: _____

Permittee: _____
Address, City, State & Zip: _____
Phone(s) and Email: _____

Contractor: _____
Address, City, State & Zip: _____
Phone(s) and Email: _____

Consultant/Engineer/Designer: _____
Address, City, State & Zip: _____
Phone(s) and Email: _____

Wetland/Vernal Pool Consultant: _____
Address, City, State & Zip: _____
Phone(s) and Email: _____

Project Location/Description: _____
Address, City, State & Zip: _____
Latitude/Longitude Coordinates: _____ Tax Map/Lot: _____
Waterway Name: _____
Work Description: _____

Provide any prior Corps permit numbers: _____
Proposed Work Dates: Start: _____ Finish: _____

Area of wetland impact: _____ SF (leave blank if work involves structures & no fill in Navigable Waters)
Area of waterway impact: _____ SF (leave blank if work involves structures & no fill in Navigable Waters)
Area of compensatory mitigation provided: _____ SF

Work will be done under the following Appendix A categories (circle all that apply):
I. Inland Waters and wetlands: 1 2 3 4 5 6 7 8 9 10 11 12 13 14 15 16 17 18 19 20 21 22 23 24
II. Navigable Waters: 1 2 3 4 5 6 7 8 9 10 11 12 13 14 15 16 17 18 19 20 21 22 23 24

Your name/signature below, as permittee, indicates that you accept and agree to comply with the terms, eligibility criteria, and general conditions of Category 1 of the Maine General Permit.

Permittee Printed Name: _____
Permittee Signature: _____ Date: _____



**US Army Corps
of Engineers**®
New England District

Appendix C: Content of Pre-Construction Notification

In addition to the following required information, the applicant must provide additional information as the Corps deems essential to make a public interest determination including, where applicable, a determination of compliance with the Section 404(b)(1) guidelines or ocean dumping criteria. Such additional information may include environmental data and information on alternate methods and sites as may be necessary for the preparation of the required environmental documentation. For a more comprehensive checklist, go to www.nae.usace.army.mil/missions/regulatory >> Forms >> Application and Plan Guideline Checklist. Please check with the Corps for project-specific requirements.

Information required for all projects:

- Corps application form ([ENG Form 4345](#)) or appropriate state application form (see Appendix E). Forms may need to be supplemented to include the information noted below.
- Proof of notification to the SHPO and the appropriate THPOs (see Appendix E).
- Official Species List for any federally listed endangered or threatened species (Instructions at Appendix D)
- Drawings, sketches, or plans (detailed engineering plans and specifications are not required) that are legible, reproducible (color is encouraged, but features must be distinguishable in black and white), no larger than 11"x17", with bar scale. Wetland area impact sheets should have the highest resolution possible to show work within Corps jurisdiction (do not just reduce project overview or cut large-scale plan into quadrant sheets). Provide locus map and a plan overview of the entire property with a key index to the individual impact sheets. A locus map be on a section of color USGS topographic map is encouraged. Digital submissions are encouraged.
- Include:
 - All direct, secondary, permanent and temporary effects the project would cause, including the anticipated amount of impacts to waters of the U.S. expected to result from the activity, in acres, linear feet, or other appropriate unit of measure.
 - Any historic permanent fill associated with each single and complete project.
 - Cross-section views of all wetland and waterway fill areas and wetland replication areas.
 - Delineation of all wetlands, other special aquatic sites (vegetated shallows, saltmarsh, mudflats, riffles and pools, coral reefs, and sanctuaries and refuges), and other waters, such as lakes and ponds, and perennial, intermittent, and ephemeral streams, on the project site. Use Federal delineation methods and include Corps wetland delineation data sheets (see GC 2).
 - MLW and MHW elevations in tidal waters. Show the HTL elevations when fill is involved. Show OHW elevation in lakes and non-tidal streams.
 - Existing and proposed conditions.
 - For vegetated shallow and eelgrass survey guidance, see www.nae.usace.army.mil/missions/regulatory >> Jurisdictional Limits and Wetlands >> Submerged Aquatic Vegetation Survey Guidance for the New England Region.
 - Show all known VPs on the project site. See GC 23 for vernal pool identification requirements.
- Volume, type, and source of fill material to be discharged into waters and wetlands, including the area(s) (in square feet or acres) of fill in wetlands, below OHW in inland waters and below the HTL

in coastal waters.

- An Official Species List of federally “listed species or critical habitat” present in the action area (see GC 8).
- A restoration plan showing how all temporary fills and structures will be removed and the area restored to pre-project conditions (see GC 43).

Information that may be required:

- Photographs of wetland/waterway to be impacted. Photos at low tide are preferred for work in tidal waters.
- For drawings, sketches, or plans:
 - The vertical datum for all coastal projects must be in U.S. survey feet and referenced to MLLW and current tidal epochs, with a reference chart showing conversion factor to NAVD88; do not use local datum. See www.nae.usace.army.mil/missions/regulatory >> Forms and Publications >>Vertical Datum - FEMA (Jul 2007);
 - The horizontal state plane coordinates shall be in U.S. survey feet and based on the appropriate state plane coordinate system.
- For the construction of a filled area or pile or float-supported platform, the use of, and specific structures to be erected on, the fill or platform.
- For the discharge of dredged or fill material into waters of the U.S. or the transportation of dredged material for the purpose of disposing of it in ocean waters, the source of the material; the purpose of the discharge, a description of the type, composition and quantity of the material; the method of transportation and disposal of the material; and the location of the disposal site.
- For the discharge of dredged or fill material into waters of the U.S., include a statement describing how impacts to waters of the U.S. are to be avoided and minimized. Include either a statement describing how impacts to waters of the U.S. are to be compensated for or a statement explaining why compensatory mitigation should not be required for the proposed impacts.
- Purpose and need for the proposed activity;
- Limits and coordinates of any Federal Navigation Project in the vicinity of the project area.
- Limits and coordinates of any proposed mooring field, reconfiguration zone or aquaculture activity. Provide coordinates for all corners;
- Schedule of construction/activity;
- Names and addresses of adjoining property owners;
- Location and dimensions of adjacent structures;
- List of authorizations required by other Federal, interstate, state, or local agencies for the work, including all approvals received or denials already made.
- Identification and description of potential impacts to Essential Fish Habitat (defined at VI. Definitions and Acronyms.
- Identification of potential discharges of pollutants to waters, including potential impacts to impaired waters, in the project area (see GC 19).
- Invasive Species Control Plan (see GC 24). For sample control plans, see www.nae.usace.army.mil/missions/regulatory >> Invasive Species.
- Wildlife Action Plan (WAP) maps. Contact Maine Inland Fisheries & Wildlife (Appendix E) or on line at http://www.maine.gov/ifw/wildlife/conservation/action_plan.html

Information for dredging projects that may be required:

- Sediment testing, including physical (e.g., grain-size analysis), chemical and biological testing. For projects proposing open water disposal, applicants are encouraged to contact the Corps as early as possible regarding sampling and testing protocols. Sampling and testing of sediments without such

contact should not occur and if done, would be at the applicant's risk.

- The area in square feet and volume of material to be dredged below mean high water.
- Existing and proposed water depths.
- Type of dredging equipment to be used.
- Nature of material (e.g., silty sand).
- Any existing sediment grain size and bulk sediment chemistry data for the proposed or any nearby projects.
- Information on the location and nature of municipal or industrial discharges and occurrence of any contaminant spills in or near the project area.
- Shellfish survey.
- Location of the disposal site (include locus sheet).
- Identification and description of any potential impacts to Essential Fish Habitat.
- Delineation of submerged aquatic vegetation (e.g., eelgrass beds).

Information for aquaculture projects that may be required:

- Maine Aquaculture guidelines and joint Corps/Maine DMR applications may be found at: www.maine.gov/dmr/aquaculture/index.htm.
- In addition to the information required above, applications must also include:
 - Whether canopy predator nets are being used.

Appendix D: Instruction for USFWS iPac Project Builder/Official Species List

NOTE: These instructions are subject to change by the USFWS. Users should check this GP's Corps webpage for the latest instructions or click [here](#).

In your internet browser go to <http://ecos.fws.gov/ipac/>

1. Click on get started.
2. Click on enter project location.
3. Search or zoom to your project location. (You can enter an address and then zoom in with your mouse).
4. Define your area. (Select the polygon tool and click around the boundary of your project.) or (Use the draw a line tool for linear projects)

Note: You can change/select the map from Streets to Satellite or Topo in the lower left corner of the map.

5. Click finished drawing then click confirm and select continue.

6. On the next page under Tasks (lower left), select Request an official species list. The pane will open. Select "request official species list" again.

7. A new page will open. Fill in the project information blanks with the project name, brief description, project type, lead agency, and contact information. Be sure to check the box to verify this is a legitimate project. Click on Submit Official Species List Request.

8. You will be sent an e-mail with instructions to complete the request by clicking on the link provided.

9. The site will open Official Species List Request Completed. Under the Maine Ecological Services Field Office address you will see "Official Species List Document". Click on that link and your document will open. Save and or print a copy and **include the entire report with your application.**

Note, you will receive a second e-mail with the same information. You can save the link in the event you need to return to the IPaC site for an updated list.

If a period of time has passed since your initial "Official Species List" identifier number was generated, you may choose to generate an "UPDATED SPECIES LIST". To do this, return to the IPaC homepage at <http://ecos.fws.gov/ipac> site. In the middle of the page, click the purple "Need an updated species list" link.

On the request an "Updated Official Species List" page, complete the information in the boxes provided. You will need the project specific official consultation code generated and stated on the original official list as well as the email address entered with the original submission.

Click "Request Updated Species List". Print, or save.

Appendix E: Contacts and Tribal Areas of Interest

1. Federal

U.S. Army Corps of Engineers
Maine Project Office
675 Western Avenue #3
Manchester, ME 04351
(207) 623-8367 (phone); (207) 623-8206 (fax)

U.S. Environmental Protection Agency
5 Post Office Square
Suite 100 (OEP05-2)
Boston, MA 02109-3912
(617) 918-1589 (phone)

U.S. Fish and Wildlife Service
Maine Field Office
17 Godfrey Drive, Suite 2
Orono, ME 04473
(207) 866-3344 (phone); (207) 866-3351 (fax)
(Federal endangered species)

National Marine Fisheries Service
Maine Field Office
17 Godfrey Drive Suite 1
Orono, ME 04473
(207) 866-7379 (phone); (207) 866-7342 (fax)
(Federal endangered species)

Federal Emergency Management Agency
99 High St.
Boston, MA 02110
(877) 336-2734 (phone)
(Flood Plain Management)

National Marine Fisheries Service
55 Great Republic Drive
Gloucester, MA 01930
(978) 281-9102 (phone); (978) 281-9301 (fax)
(Federal endangered species & EFH)

National Park Service
North Atlantic Region
15 State Street
Boston, MA 02109
(617) 223-5203 (phone)
(Wild and Scenic Rivers)

Commander (dpb)
First Coast Guard District
One South Street - Battery Bldg
New York, NY 10004-1466
(212) 668-7021 (phone); (212) 668-7967 (fax)
(bridge permits)

2. State of Maine

a. Department of Environmental Protection (*State permits & Water Quality Certifications*)

Division of Land Resource Regulation
Bureau of Land and Water Quality
17 State House Station
Augusta, Maine 04333
(207) 287-7688 (phone)

Southern Maine Regional Office
312 Canco Road
Portland, Maine 04103
(201) 822-6300 (phone)

Eastern Maine Regional Office
106 Hogan Road
Bangor, Maine 04401
(207) 941-4570 (phone)

Northern Maine Regional Office
1235 Central Drive - Skyway Park
Presque Isle, Maine 04769
(207) 764-0477 (phone)

b. Department of Agriculture, Conservation and Forestry

i. Maine Land Use Planning Commission (LUPC) (State permits & Water Quality Certifications in the unorganized areas of the State)

Augusta Office
22 State House Station
Augusta, Maine 04333-0022
(207) 287-2631 (phone); (207) 287-7439 (fax)

Downeast Regional Office
106 Hogan Rd, Suite 8
Dorothea Dix Complex
Bangor, Maine 04401
(207) 941-4052 (phone); (207) 941-4222 (fax)

Greenville Regional Office
43 Lakeview Drive
P.O. Box 1107
Greenville, Maine 04441
(207) 695-2466 (phone); (207) 695-2380 (fax)

Ashland Regional Office
45 Radar Road
Ashland, ME 04732-3600
(207) 435-7963 (phone); (207) 435-7184 (fax)

Rangely Regional Office
133 Fyfe Road
PO Box 307
West Farmington, ME 04992
(207) 670-7493 (phone); (207) 287-7439 (fax)

East Millinocket Regional Office
191 Main Street
East Millinocket, ME 04430
(207) 746-2244 (phone); (207) 746-2243 (fax)

ii. Maine Coastal Program

Department of Agriculture, Conservation and Forestry
Bureau of Resource Information and Land Use Planning
17 Elkins Lane {physical address}
State House Station 93
Augusta, Maine 04333-0038
(207) 287-2801 (phone); (207) 287-2353 (fax)
(CZM consistency determinations)

iii. Division of Parks and Public Lands

22 State House Station
Augusta, Maine 04333
(207) 287-3061 (phone); (207) 287-6170 (fax)
(submerged lands leases)

c. Department of Marine Resources

P.O. Box 8
West Boothbay Harbor, Maine 04575
(207) 633-9500 (phone); (207) 624-6024 (fax)
(aquaculture leases)

3. Historic Properties

a. State Historic Preservation Officer (SHPO)

Mr. Kirk F. Mohney, Director

Maine Historic Preservation Commission (MHPC)
65 State House Station
Augusta, Maine 04333-0065
(207) 287-2132 (phone); (207) 287-2335 (fax)
Area of concern: The entire State of Maine

b. Tribal Historic Preservation Officers (THPOs)

Note: The area of concern for each tribe is the entire State of Maine

THPO & Environmental Planner
Houlton Band of Maliseet Indians
88 Bell Road
Littleton, Maine 04730
(207) 532-4273, x215 (phone)
(207) 532-6883 (fax)
envplanner@maliseets.com
ogs1@maliseets.com

THPO
Aroostook Band of Micmacs
7 Northern Road
Presque Isle, Maine 04769
(207) 764-1972 (phone); (207) 764-7667 (fax)
jpictou@mimca-nsn.gov

THPO
Passamaquoddy Tribe of Indians
Pleasant Point Reservation
P.O. Box 343
Perry, Maine 04667
(207) 853-2600 (phone); (207) 853-6039 (fax)
soctomah@gmail.com

THPO
Penobscot Nation
Cultural and Historic Preservation Dept.
12 Wabanaki Way
Indian Island, Maine 04468
(207) 817-7471 (phone)
chris.sockalexis@penobscotnation.org

THPO
Passamaquoddy Tribe of Indians
Indian Township Reservation
P.O. Box 301
Princeton, Maine 04668
(207) 796-2301 (phone)
(207) 796-5256 (fax); soctomah@gmail.com

4. Organizational Websites (Note – Subject to Change):

U.S. Army Corps of Engineers, N.E. District	www.nae.usace.army.mil/missions/regulatory.aspx
U.S. Army Corps of Engineers, Headquarters	See above link>>Useful Links>>Federal Agency Links
U.S. Environmental Protection Agency	www.epa.gov/owow/wetlands
National Marine Fisheries Service	www.nmfs.noaa.gov
U.S. Fish and Wildlife Service	www.fws.gov/mainefieldoffice
National Park Service	www.nps.gov/rivers/index.html
Maine Department of Environmental Protection	www.maine.gov/dep
Maine Department of Agriculture, Conservation and Forestry	www.maine.gov/acf/index.shtml
Maine Land Use Planning Commission	www.maine.gov/doc/lupc/commission/offices.shtml
Maine Department of Marine Resources	www.maine.gov/dmr/index.htm
State of Maine - Aquaculture Guidelines	www.maine.gov/dinr/aquaculture/index.htm

Appendix F: Definitions

Definitions

Attendant Features: Occurring with or as a result of; accompanying.

Biodegradable: A material that decomposes into elements found in nature within a reasonably short period of time and will not leave a residue of plastic or a petroleum derivative in the environment after degradation. Examples of biodegradable materials include jute, sisal, cotton, straw, burlap, coconut husk fiber (coir) or excelsior. In contrast, degradable plastics break down into plastic fragments that remain in the environment after degradation.

Boating facilities: These provide, rent or sell mooring space, such as marinas, yacht clubs, boat yards, dockminiums, town facilities, land/home owners, etc. Not classified as boating facilities are piers shared between two abutting properties or town mooring fields that charge an equitable user fee based on the actual costs incurred.

Brushing the Flats: The placement of tree boughs, wooden lath structure, or small-mesh fencing on mudflats, or any bottom disturbance (e.g., discing, plowing, raking, etc.), to enhance recruitment of shellfish.

Buffer Zone: The buffer zone of an FNP is equal to three times the authorized depth of the FNP.

Construction mats: Constructions, swamp and timber mats (herein referred to as “construction mats”) are generic terms used to describe structures that distribute equipment weight to prevent wetland damage while facilitating passage and providing work platforms for workers and equipment. They are comprised of sheets or mats made from a variety of materials in various sizes. A timber mat consists of large timbers bolted or cabled together. Corduroy roads, which are not considered to be construction mats, are cut trees and/or saplings with the crowns and branches removed, and the trunks lined up next to one another. Corduroy roads are typically installed as permanent structures. Like construction mats, they are considered as fill whether they are installed temporarily or permanently.

Cumulative effects: See “Direct, secondary, and cumulative effects.”

Direct, secondary, and cumulative effects:

Direct Effects: The loss of aquatic ecosystem within the footprint of the discharge of dredged or fill material. Direct effects are caused by the action and occur at the same time and place.

Secondary Effects: These are effects on an aquatic ecosystem that are associated with a discharge of dredged or fill materials, but do not result from the actual placement of the dredged or fill material. Information about secondary effects on aquatic ecosystems shall be considered prior to the time final Section 404 action is taken by permitting authorities. Some examples of secondary effects on an aquatic ecosystem are a) aquatic areas drained, flooded, fragmented, or mechanically cleared; b) fluctuating water levels in all impoundment and downstream associated with the operation of a dam, c) septic tank leaching and surface runoff from residential or commercial developments on fill, and d) leachate and runoff from a sanitary landfill located in waters of the U.S. See 40 CFR 230.11(h).

Cumulative Effects: The changes in an aquatic ecosystem that are attributable to the collective effect of a number of individual 1) discharges of dredged or fill material, or 2) structures. Although the impact of a particular discharge may constitute a minor change in itself, the cumulative effect of numerous such piecemeal changes can result in a major impairment of the water resources and interfere with the productivity and water quality of existing aquatic ecosystems. See 40 CFR 230(g).

Dredging:

Maintenance Dredging: Includes areas and depths previously authorized by the Corps and dredged. The Corps may require proof of authorization. Maintenance dredging typically refers to the routine removal of accumulated sediment from channel beds to maintain the design depths of navigation channels, harbors, marinas, boat launches and port facilities. Routine maintenance dredging is conducted regularly for navigational purposes (typically at least once every ten years) and does not include any expansion of the previously dredged area or depth. The Corps may review a maintenance dredging activity as new dredging if sufficient time has elapsed to allow for the colonization of SAS,

shellfish, etc. The main characteristics of maintenance dredging projects are variable quantities of material; soft, uncompacted soil; contaminant content possible; thin layers of material; occurring in navigation channels and harbors; repetitive activity

New Dredging: Dredging of an area or to a depth that has never been authorized by the Corps or dredged.

Dredged material & discharge of dredged material: These are defined at 323.2(c) and (d). The term dredged material means material that is excavated or dredged from waters of the U.S.

Essential Fish Habitat (EFH): This is broadly defined to include those waters and substrate necessary to fish for spawning, breeding, feeding, or growth to maturity.

Fill material & discharge of fill material: These are defined at 323.2(e) and (f). The term fill material is defined as material placed in waters of the U.S. where the material has the effect of either replacing any portion of a water of the U.S. with dry land or changing the bottom elevation of any portion of a water of the U.S.

Federal anchorages, Federal channels and Federal turning basin: Refer to Appendix H for those in Maine

Federal navigation projects (FNPs): These areas are maintained by the Corps; authorized, constructed and maintained on the premise that they will be accessible and available to all on equal terms; and are comprised of Federal Anchorages, Federal Channels and Federal Turning Basins. The buffer zone is equal to three times the authorized depth of a FNP. More information on the following FNPs is provided at www.nae.usace.army.mil/missions/navigation.aspx >> Navigation Projects.

Flume: An open artificial water channel, in the form of a gravity chute, that leads water from a diversion dam or weir completely aside a natural flow. A flume can be used to measure the rate of flow.

Frac out: During normal drilling operations, drilling fluid travels up the borehole into a pit. When the borehole becomes obstructed or the pressure becomes too great inside the borehole, the ground fractures and fluid escapes to the surface.

Independent utility: A test to determine what constitutes a single and complete non-linear project in the Corps regulatory program. A project is considered to have independent utility if it would be constructed absent the construction of other projects in the project area. Portions of a multi-phase project that depend upon other phases of the project do not have independent utility. Phases of a project that would be constructed even if the other phases were not built can be considered as separate single and complete projects with independent utility.

Individual Permit: A Department of the Army authorization that is issued following a case-by-case evaluation of a specific structure or work in accordance with the procedures of 33 CFR 322, or a specific project involving the proposed discharge(s) in accordance with the procedures of 33 CFR 323, and in accordance with the procedures of 33 CFR 325 and a determination that the proposed discharge is in the public interest pursuant to 33 CFR 320.

Maintenance: Regulations on maintenance are provided at 33 CFR 323.4. The following definitions are applicable:

Minor deviations: Deviations in the structure's configuration or filled area, including those due to changes in materials, construction techniques, or current construction codes or safety standards, which are necessary to make repair, rehabilitation, or replacement are permitted, provided the adverse environmental effects resulting from such repair, rehabilitation, or replacement are minimal.

Currently serviceable: Useable as is or with some maintenance, but not so degraded as to essentially require reconstruction.

Marina reconfiguration zone: A Corps-authorized area in which permittees may rearrange pile-supported structures and floats without additional authorizations. A reconfiguration zone does not grant exclusive privileges to an area or an increase in structure or float area.

Navigable waters of the U.S.: See Waters of the U.S. below.

Overall project: See "single and complete linear project" below.

Practicable: Available and capable of being done after taking into consideration cost, existing technology, and logistics in light of overall project purposes.

Permanent impacts: Permanent impacts means waters of the U.S. that are permanently affected by filling, flooding, excavation, or drainage because of the regulated activity. Permanent impacts include permanent discharges of dredged or fill material that change an aquatic area to dry land, increase the bottom elevation of a waterbody, or change the use of a waterbody. Temporary impacts include waters of the U.S. that are temporarily filled, flooded, excavated, drained or mechanically cleared because of the regulated activity.

Pre-construction notification (PCN): A request submitted by the project proponent to the Corps for confirmation that a particular activity is authorized by this GP. The request may be a permit application, letter, or similar document that includes information about the proposed work and its anticipated environmental effects. Pre-construction notification may be required by the terms and conditions of these GPs. A PCN may be voluntarily submitted in cases where PCN is not required and the project proponent wants confirmation that the activity is authorized under this GP.

Secondary effects: See “Direct, secondary, and cumulative effects.”

Single and complete linear project: A linear project is a project constructed for the purpose of getting people, goods, or services from a point of origin to a terminal point, which often involves multiple crossings of one or more waterbodies at separate and distant locations. The term “single and complete project” is defined as that portion of the total linear project proposed or accomplished by one owner/developer or partnership or other association of owners/developers that includes all crossings of a single water of the U.S. (i.e., a single waterbody) at a specific location. For linear projects crossing a single or multiple waterbodies several times at separate and distant locations, each crossing is considered a single and complete project for the purposes of this GP. However, individual channels in a braided stream or river, or individual arms of a large, irregularly shaped wetland or lake, etc., are not separate waterbodies, and crossings of such features cannot be considered separately.

The overall project, for purposes of this GP, includes all regulated activities that are reasonably related and necessary to accomplish the project purpose.

Single and complete non-linear project: For non-linear projects, the term “single and complete project” is defined at 33 CFR 330.2(i) as the total project proposed or accomplished by one owner/developer or partnership or other association of owners/developers. For non-linear projects, the single and complete project must have independent utility (see definition).

Special aquatic sites: These include inland and saltmarsh wetlands, mud flats, vegetated shallows, sanctuaries and refuges, coral reefs, and riffle and pool complexes. These are defined at 40 CFR 230 Subpart E.

Stream channelization: The manipulation of a stream’s course, condition, capacity, or location that causes more than minimal interruption of normal stream processes. A channelized stream remains a water of the United States.

Temporary impacts: See permanent impacts above.

Utility line: Any pipe or pipeline for the transportation of any gaseous, liquid, liquescent, or slurry substance, for any purpose, and any cable, line, or wire for the transmission for any purpose of electrical energy, telephone, and telegraph messages, and radio and television communication. The term ‘utility line’ does not include activities that drain a water of the U.S., such as drainage tile or French drains, but it does apply to pipes conveying drainage from another area.

Vegetated shallows: Permanently inundated areas that under normal circumstances support communities of rooted aquatic vegetation, such as eelgrass and widgeon grass (*Rupiamaritima*) in marine systems (doesn’t include salt marsh) as well as a number of freshwater species in rivers and lakes. Note: These areas are also commonly referred to as submerged aquatic vegetation (SAV).

Vernal pools (VPs): For the purposes of this GP, VPs are depressional wetland basins that typically go dry in most years and may contain inlets or outlets, typically of intermittent flow. Vernal pools range in both size and depth depending upon landscape position and parent material(s). Pools usually

support one or more of the following obligate indicator species: wood frog, spotted salamander, blue-spotted salamander, marbled salamander, Jefferson's salamander and fairy shrimp. However, they should preclude sustainable populations of predatory fish.

VP areas are:

- Depression (includes the VP depression up to the spring or fall high water mark, and includes any vegetation growing within the depression),
- Envelope (area within 100 feet of the VP depression's edge), and
- Critical terrestrial habitat (area within 100-750 feet of the VP depression's edge).

Note: See footnote to GC 23. The Corps may determine during the PCN review that a waterbody should not be designated as a VP based on available evidence.

Water diversions: Water diversions are activities such as bypass pumping (e.g., "dam and pump") or water withdrawals. Temporary flume pipes, culverts or cofferdams where normal flows are maintained within the stream boundary's confines aren't water diversions. "Normal flows" are defined as no change in flow from pre-project conditions.

Weir: A barrier across a river designed to alter the flow characteristics. In most cases, weirs take the form of a barrier, smaller than most conventional dams, across a river that causes water to pool behind the structure (not unlike a dam) and allows water to flow over the top. Weirs are commonly used to alter the flow regime of the river, prevent flooding, measure discharge and help render a river navigable.

Waters of the U.S. & Waters of the United States (U.S.): The term waters of the U.S. and all other terms relating to the geographic scope of jurisdiction are defined at 33 CFR 328. Also see Section 502(7) of the Federal CWA [33 USC 1352(7)]. Waters of the U.S. include jurisdictional wetlands. Not all waters and wetlands are jurisdictional. Contact the Corps with any questions regarding jurisdiction.

Navigable waters: Refer to 33 CFR 329. These waters include the following federally designated navigable waters in New England. This list represents only those waterbodies for which affirmative determinations have been made; absence from this list should not be taken as an indication that the waterbody is not navigable:

ME: All tidal waters; Kennebec River to Moosehead Lake; Penobscot River to the confluence of the East and West Branch at Medway, Maine; Lake Umbagog within the State of Maine.

Appendix G: Additional References

1. GC 2: Federal Jurisdictional Boundaries.

(a) Corps Wetlands Delineation Manual, regional supplements, and Corps Wetland Delineation Data Sheets: www.nae.usace.army.mil/missions/regulatory and then “Wetlands and Jurisdictional Limits.”

(b) The USFWS publishes the 1988 National List of Plant Species that Occur in Wetlands (www.nwi.fws.gov).

The Natural Resources Conservation Service (NRCS) publishes the current hydric soil definition, criteria and lists: <http://soils.usda.gov/use/hydric>. For the Field Indicators for Identifying Hydric Soils in N.E., see www.neiwpsc.org/hydricsoils.asp.

2. GC 5: Single and Complete Project.

Single and complete project means the total project proposed or accomplished by one owner/developer or partnership or other association of owners/developers. For example, if construction of a residential development affects several different areas of a headwater or isolated water, or several different headwaters or isolated waters, the cumulative total of all filled areas should be the basis for deciding whether or not the project will be covered by Category 1 or 2.

The *Independent utility* test is used to determine what constitutes a single and complete project in the Corps regulatory program. A project is considered to have independent utility if it would be constructed absent the construction of other projects in the project area. Portions of a multi-phase project that depend upon other phases of the project do not have independent utility. Phases of a project that would be constructed even if the other phases were not built can be considered as separate single and complete projects with independent utility.

3. GC 8: Threatened and Endangered Species.

(a) The following NMFS site must be referenced to ensure that listed species or critical habitat are not present in the action area [GC 8(b)] or to provide information on federally-listed species or habitat [GC 8(e)]: www.nero.noaa.gov/prot_res/esp/ListE&Tspec.pdf. Contact the USFWS for information to check for the presence of listed species (see Appendix D for contact information & procedures).

(b) The Endangered Species Act Consultation Handbook – Procedures for Conducting Section 7 Consultations and Conferences, defines action area as “all areas to be affected directly or indirectly by the federal action and not merely the immediate area involved in the action. [50 CFR 402.02].”

4. GC 42: Essential Fish Habitat.

As part of the GP screening process, the Corps may coordinate with NMFS in accordance with the 1996 amendments to the Magnuson-Stevens Fishery Conservation and Management Act to protect and conserve the habitat of marine, estuarine and anadromous finfish, mollusks, and crustaceans. This habitat is termed “Essential Fish Habitat (EFH)”, and is broadly defined to include “those waters and substrate necessary to fish for spawning, breeding, feeding, or growth to maturity.” There are EFH waters throughout inland and coastal waters in Maine. For additional information, see the EFH regulations 50 CFR 600 at www.nero.noaa.gov/hcd including the “Guide for EFH Descriptions” at www.nero.noaa.gov/hcd/list.htm. Additional information on the location of EFH can be obtained from NMFS (see Appendix D for contact information).

5. GC 4: Avoidance, Minimization and Compensatory Mitigation.

(a) See www.nae.usace.army.mil/missions/regulatory and then “Mitigation” to view the April 10, 2008 “Final Compensatory Mitigation Rule” (33 CFR 332) and related documents. The Q&A document states: “In order to reduce risk and uncertainty and help ensure that the required compensation is provided, the rule establishes a preference hierarchy for mitigation options. The most preferred option

is mitigation bank credits, which are usually in place before the activity is permitted. In-lieu fee program credits are second in the preference hierarchy, because they may involve larger, more ecologically valuable compensatory mitigation projects as compared to permittee-responsible mitigation. Permittee-responsible mitigation is the third option, with three possible circumstances: (1) conducted under a watershed approach, (2) on-site and in kind, and (3) off-site/out-of-kind.

(b) Compensatory mitigation may take the form of wetland preservation, restoration, enhancement, creation, and/or in lieu fee (ILF) for inclusion into the Natural Resources Mitigation Fund for projects in DEP and LURC territories. Avoidance of wetland impacts will reduce the ILF dollar total for applicants. The ILF compensation program was established to provide applicants with a flexible compensation option over and above traditional permittee responsible compensation projects. See the Maine ILF Agreement at www.nae.usace.army.mil/missions/regulatory, “Mitigation” and then “Maine,” or www.maine.gov/dep/blwq/docstand/nrpa/ILF_and_NRCP/index.htm.

6. GCs 24, 15, and 43: Invasive Species.

(a) Information on what are considered “invasive species” is provided in our “Compensatory Mitigation Guidance” document at www.nae.usace.army.mil/missions/regulatory under “Mitigation.” The “Invasive Species” section has a reference to our “Invasive Species Control Plan (ISCP) Guidance” document, located at www.nae.usace.army.mil/missions/regulatory under “Invasive Species,” which provides information on preparing an ISCP.

(b) The June 2009 “Corps of Engineers Invasive Species Policy” is at www.nae.usace.army.mil/missions/regulatory under “Invasive Species” and provides policy, goals and objectives.

7. GC 44: Bank Stabilization.

This generally eliminates bodies of water where the reflected wave energy may interfere with or impact on harbors, marinas, or other developed shore areas. A revetment is sloped and is typically employed to absorb the direct impact of waves more effectively than a vertical seawall. It typically has a less adverse effect on the beach in front of it, abutting properties and wildlife. See the Corps Coastal Engineering Manual EM 1110-2-1100 at www.nae.usace.army.mil/missions/regulatory under “Useful Links and Documents” for design and construction guidance.

8. GC 45: Stream and Wetland Crossings.

(a) Projects should be designed and constructed to ensure long-term success using the most recent manual located at www.nae.usace.army.mil/missions/regulatory under “Stream and River Continuity,” currently “Stream Simulation: An Ecological Approach to Providing Passage for Aquatic Organisms at Road-Stream Crossings, by the U.S. Forest Service.” Section 5.3.3 is of particular importance. Sections 7.5.2.3 Construction Methods and 8.2.11 Stream-Simulation Bed Material Placement both show important steps in the project construction.

(b) For more information on High-Quality Stream Segments and their components see:

i. High-Quality Stream Segments are shown at www.maine.gov/dep/gis/datamaps.

ii. Class A Waters or Class AA Waters:

www.mainelegislature.org/legis/statutes/38/title38sec465.html, and

www.mainelegislature.org/legis/statutes/38/title38sec467.html.

iii. Outstanding river segments www.mainelegislature.org/legis/statutes/38/title38sec480-P.html.

(c) The Massachusetts Dam Removal and the Wetland Regulations offer guidance to evaluate the positive and negative impacts of culvert replacement, including the loss of upstream wetlands, which may be offset by the overall benefits of the river restoration. See

www.nae.usace.army.mil/missions/regulatory and then “Stream and River Continuity.”

(d) The ME DOT's document "Waterway and Wildlife Crossing Policy and Design Guide for Aquatic Organism, Wildlife Habitat, and Hydrologic Connectivity," 3rd Edition, July 2008, may be used as guidance to evaluate impacts to aquatic, wildlife and surface water resources when designing, constructing, repairing and maintaining stream crossings. Note: Adherence to this DOT document does not ensure compliance with this GP. Projects must comply with the requirements of this GP including GC 45 and the Corps General Stream Crossing Standards contained therein.

www.maine.gov/mdot/environmental-office-homepage/fishpassage/3rd%20edition%20-%20merged%20final%20version%207-01-08a1.pdf.

(e) GC 45(f): The Skidder Bridge Fact Sheet at www.nae.usace.army.mil/missions/regulatory under "Stream and River Continuity" may be a useful temporary span construction method.

9. GC 45: Wetland Crossings. The Maine DEP's crossing standards are at 06-096 DEP, Chapter 305: Permits by Rule, 9 & 10) Crossings (utility lines, pipes and cables). www.maine.gov/dep/blwq/rules/NRPA/2009/305/305_effective_2009.pdf

10. GC 23: Protection of Vernal Pools.

(a) The state's Significant Wildlife Habitat rules (Chapter 335, Section 9(C) "Habitat management standards for significant vernal pool habitat") are located at

www.maine.gov/dep/blwq/docstand/nrpapage.htm#rule under "Rules."

(b) The following documents provide conservation recommendations:

i. Best Development Practices: Conserving pool-breeding amphibians in residential and commercial development in the northeastern U.S., Calhoun and Klemens, 2002. Chapter III, Management Goals and Recommendations, Pages 15 – 26, is particularly relevant. (Available for purchase at www.maineaudubon.org/resource/index.shtml and on Corps website*.)

ii. Science and Conservation of Vernal Pools in Northeastern North America, Calhoun and deMaynadier, 2008. Chapter 12, Conservation Recommendations section, Page 241, is particularly relevant. (Available for purchase via the internet. Chapter 12 is available on Corps website*.)

* www.nae.usace.army.mil/reg under "Vernal Pools."

(c) Cape Cod Curbing: For smaller roads and driveways, the most important design feature to consider is curbing. Granite curbs and some traditional curbing can act as a barrier to amphibian and hatchling turtle movements. Large numbers of salamanders have been intercepted in their migrations by curbs and catch basins. Use of Cape Cod curbs rather than traditional curbing may be one solution. Alternatively, where storm water management systems require more traditional curbing, it may be possible to design in escape ramps on either side of each catch basin. Cape Cod curbing is shown on Page 35 of the document cited in 10.b.i above. Bituminous material is not required; other materials such as granite are acceptable.

(d) The VP Directional Buffer Guidance document is located at www.nae.usace.army.mil/missions/regulatory under: 1) "State General Permits" and then "Maine," and 2) "Vernal Pools."

11. GC 29: Maintenance. River restoration projects that are designed to accommodate the natural dynamic tendencies of the fluvial system are maintained in accordance with the project's design objectives (Category 1) or the Corps authorization letter (Category 2). These projects are generally designed to support and implement channel assessment and management practices that recognize a stream's natural dynamic tendencies.

Appendix H: Federal Navigation Projects in Maine

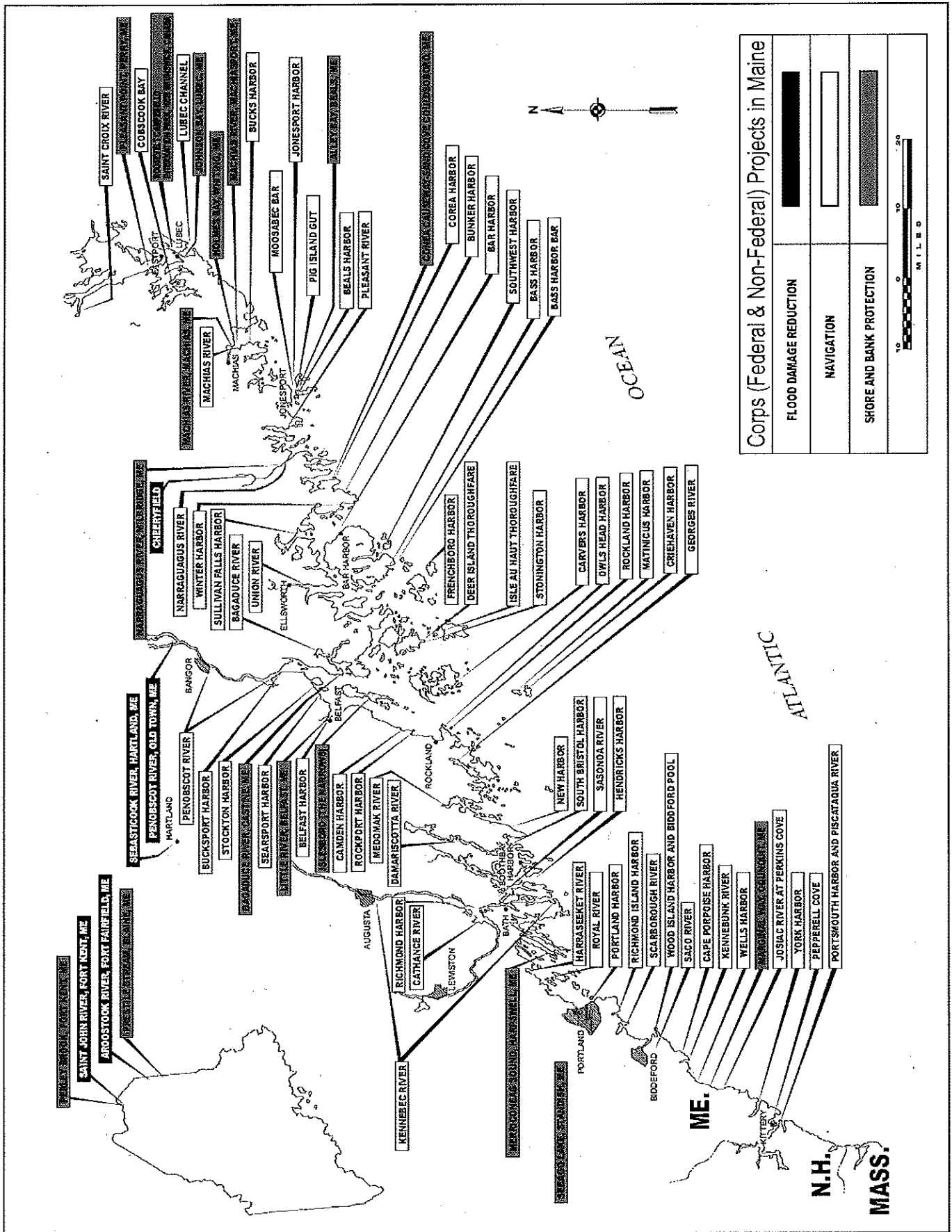

**DEPARTMENT OF ENVIRONMENTAL PROTECTION
PERMIT BY RULE NOTIFICATION FORM**
(For use with DEP Regulation, Natural Resources Protection Act- Permit by Rule Standards, Chapter 305)
PLEASE TYPE OR PRINT IN *BLACK INK ONLY*

APPLICANT INFORMATION (Owner)		AGENT INFORMATION (If Applying on Behalf of Owner)	
Name:		Name:	
Mailing Address:		Mailing Address:	
Town:		Town:	
State and Zip Code:		State and Zip Code:	
Daytime Phone #:		Daytime Phone #:	
Email Address:		Email Address:	

PROJECT INFORMATION							
Part of a larger project? (check one):	<input type="checkbox"/> Yes <input type="checkbox"/> No	After the Fact? (check one):	<input type="checkbox"/> Yes <input type="checkbox"/> No	Project involves work below mean low water? (check one):	<input type="checkbox"/> Yes <input type="checkbox"/> No	Name of waterbody:	
Project Town:		Project Location (Address):		Map & Lot Number:			
Brief Project Description:							
Brief Directions to Site:							

PERMIT BY RULE (PBR) SECTIONS (Check at least one): I am filing notice of my intent to carry out work which meets the requirements for Permit By Rule (PBR) under DEP Rules, Chapter 305. **I and my agents, if any, have read and will comply with all of the standards in the Sections checked below.**

- | | | |
|---|---|--|
| <input type="checkbox"/> Sec. (2) Act. Adj. to Protected Natural Res. | <input type="checkbox"/> Sec.(10) Stream Crossing | <input type="checkbox"/> Sec. (17) Transfers/Permit Extension |
| <input type="checkbox"/> Sec. (3) Intake Pipes | <input type="checkbox"/> Sec. (11) State Transportation Facil. | <input type="checkbox"/> Sec. (18) Maintenance Dredging |
| <input type="checkbox"/> Sec. (4) Replacement of Structures | <input type="checkbox"/> Sec. (12) Restoration of Natural Areas | <input type="checkbox"/> Sec. (19) Activities in/on/over significant vernal pool habitat |
| <input type="checkbox"/> Sec. (5) REPEALED | <input type="checkbox"/> Sec. (13) F&W Creation/Enhance/Water Quality Improvement | <input type="checkbox"/> Sec. (20) Activities located in/on/over high or moderate value inland waterfowl & wading bird habitat or shorebird feeding & roosting areas |
| <input type="checkbox"/> Sec. (6) Removal of Rocks or Vegetation | <input type="checkbox"/> Sec. (14) REPEALED | |
| <input type="checkbox"/> Sec. (7) Shoreline Stabilization | <input type="checkbox"/> Sec. (15) Public Boat Ramps | |
| <input type="checkbox"/> Sec. (8) Intake Pipes | <input type="checkbox"/> Sec. (16) Coastal Sand Dune Projects | |
| <input type="checkbox"/> Sec. (9) Utility Crossing | | |

State Agency-
Internal Bill

NOTE: Municipal permits may also be required. Contact your local code enforcement office for more information. Federal permits may be required for stream crossings and for projects involving wetland fill. Contact the Army Corps of Engineers at the Maine Project Office for more information.

NOTIFICATION FORMS CANNOT BE ACCEPTED WITHOUT THE NECESSARY ATTACHMENTS

Attach all required submissions for the PBR Section(s) checked above. The required submissions for each PBR Section are outlined in Chapter 305 and may differ depending on the Section you are submitting under.

Attach a check for the correct fee made payable to: "Treasurer, State of Maine". The current fee for NRPA PBR Notifications can be found at the Department's website: <http://www.maine.gov/dep/feesched.pdf>

Attach a location map that clearly identifies the site (U.S.G.S. topo map, Maine Atlas & Gazetteer, or similar).

Attach Proof of Legal Name if applicant is a corporation, LLC, or other legal entity. Provide a copy of Secretary of State's registration information (available at <http://icrs.informe.org/nei-sos-icrs/ICRS?MainPage=x>) Individuals and municipalities are not required to provide any proof of identity.

I authorize staff of the Departments of Environmental Protection, Inland Fisheries & Wildlife, and Marine Resources to access the project site for the purpose of determining compliance with the rules.

I also understand that this PBR becomes effective 14 calendar days after receipt by the Department *unless the Department approves or denies the PBR prior to that date.*

By signing this Notification Form, I represent that the project meets all applicability requirements and standards in the rule and that the applicant has sufficient title, right, or interest in the property where the activity takes place.

Signature of Agent or Applicant:		Date:	
----------------------------------	--	-------	--

Keep a copy as a record of permit. Send the form with attachments via certified mail or hand deliver to the Maine Dept. of Environmental Protection at the appropriate regional office listed below. The DEP will send a copy to the Town Office as evidence of the DEP's receipt of notification. No further authorization by DEP will be issued after receipt of notice. Permits are valid for two years. **Work carried out in violation of any standard is subject to enforcement action.**

- | | | | |
|--|---|---|---|
| AUGUSTA DEP
17 STATE HOUSE STATION
AUGUSTA, ME 04333-0017
(207)287-7688 | PORTLAND DEP
312 CANCO ROAD
PORTLAND, ME 04103
(207)822-6300 | BANGOR DEP
106 HOGAN ROAD
BANGOR, ME 04401
(207)941-4570 | PRESQUE ISLE DEP
1235 CENTRAL DRIVE
PRESQUE ISLE, ME 04769
(207)764-0477 |
|--|---|---|---|

OFFICE USE ONLY	Ck.#		Staff	Staff	
PBR #	FP	Date	Acc. Date	Def. Date	After Photos 230

11. State transportation facilities

A. Applicability

- (1) This section applies to the maintenance, repair, reconstruction, rehabilitation, replacement or minor construction of a State Transportation Facility carried out by, or under the authority of, the Maine Department of Transportation (MaineDOT) or the Maine Turnpike Authority, including any testing or preconstruction engineering, and associated technical support services.
- (2) This section does not apply to an activity within a coastal sand dune system.

NOTE: The construction of a transportation facility other than roads and associated facilities may be subject to the Storm Water Management Law, 38 M.R.S.A. Section 420-D.

B. Standards

- (1) Photographs of the area to be altered by the activity must be taken before work on the site begins. The photographs must be kept on file and be made available at the request of the DEP.
- (2) The activity must be reviewed by the Department of Inland Fisheries and Wildlife and the Department of Marine Resources, as applicable. The applicant must coordinate with the reviewing agencies and incorporate any recommendations from those agencies into the performance of the activity.
- (3) All construction activities undertaken must be detailed in a site-specific Soil Erosion and Water Pollution Control Plan and conducted in accordance with MaineDOT's Best Management Practices for Erosion and Sediment Control, dated January 2000, and Standard Specifications, dated December 2002.
- (4) Alignment changes may not exceed a distance of 200 feet between the old and new center lines in any natural resource.
- (5) The activity may not alter more than 300 feet of shoreline (both shores added together) within a mile stretch of any river, stream or brook, including any bridge width or length of culvert.
- (6) The activity may not alter more than 150 feet of shoreline (both shores added together) within a mile stretch of any outstanding river segment identified in 38 M.R.S.A. 480-P, including any bridge width or length of culvert.
- (7) The activity must minimize wetland intrusion. The activity is exempt from the provisions of Chapter 310, the Wetland and Waterbodies Protection Rules, if the activity alters less than 15,000 square feet of natural resources per mile of roadway (centerline measurement) provided that the following impacts are not exceeded within the 15,000 square foot area:
 - (a) 1,000 square feet of coastal wetland consisting of salt tolerant vegetation or shellfish habitat; or

- (b) 5,000 square feet of coastal wetland not containing salt tolerant vegetation or shellfish habitat; or
- (c) 1,000 square feet of a great pond.

All other activities must be performed in compliance with all sections of Chapter 310, the Wetland Protection Rules, except 310.2(C), 5(A), 9(A), 9(B) and 9(C).

- (8) The activity may not permanently block any fish passage in any watercourse containing fish. The applicant must coordinate with the reviewing agencies listed in paragraph 2 above to improve fish passage and incorporate any recommendations from those agencies into the performance of the activity.

NOTE: For guidance on meeting the design objectives for fish passage, including peak flow, maximum velocity, mining depth and gradient, see the MaineDOT Waterbody and Wildlife Crossing Policy and Design Guide (July 2008), developed in conjunction with state and federal resource and regulatory agencies.

- (9) Rocks may not be removed from below the normal high water line of any coastal wetland, freshwater wetland, great pond, river, stream or brook except to the minimum extent necessary for completion of work within the limits of construction.
- (10) If work is performed in a river, stream or brook that is less than three feet deep at the time and location of the activity, the applicant must isolate the work area from the resource and divert stream flows around the work area, maintaining downstream flows while work is in progress.
- (11) Wheeled or tracked equipment may not operate in the water. Equipment operating on the shore may reach into the water with a bucket or similar extension. Equipment may cross streams on rock, gravel or ledge bottom. If avoiding the operation of wheeled or tracked equipment in the water is not possible, the applicant must explain the need to operate in the water. Approval from the DEP to operate in the water must be in writing, and any recommendations from the DEP must be incorporated into the performance of the activity.
- (12) All wheeled or tracked equipment that must travel or work in a vegetated wetland area must travel and work on mats or platforms.
- (13) Any debris or excavated material must be stockpiled either outside the wetland or on mats or platforms. Erosion and sediment control best management practices must be used, where necessary, to prevent sedimentation. Any debris generated during the activity must be prevented from washing downstream and must be removed from the wetland or water body. Disposal of debris must be in conformance with the Maine Hazardous Waste, Septage and Solid Waste Management Act, 38 M.R.S.A. Section 1301 *et seq.*
- (14) Work below the normal high water line of a great pond, river, stream or brook must be done at low water except for emergency work or work agreed to by the resource agencies listed in paragraph 2 above.
- (15) Perimeter controls must be installed before the work starts. Disturbance of natural resources beyond the construction limits shown on the plans is not allowed under this rule.

NOTE: Guidance on the location of construction limits can be obtained from the on site Construction Manager.

- (16) The use of untreated lumber is preferred. Lumber pressure treated with chromated copper arsenate (CCA) may be used only if necessary and only if use is allowed under federal law and not prohibited from sale under 38 M.R.S.A. 1682, and provided it is cured on dry land in a manner that exposes all surfaces to the air for a period of at least 21 days prior to construction. Wood treated with creosote or pentachlorophenol may not be used where it will contact water.
- (17) A temporary road for equipment access must be constructed of crushed stone, blasted ledge, or similar materials that will not cause sedimentation or restrict fish passage. Such roads must be completely removed at the completion of the activity. In addition, any such temporary roads which are in rivers, streams or brooks, must allow for a passage of stormwater flows associated with a 10-year storm.
- (18) Non-native species may not be planted in restored areas.
- (19) Disposal of debris must be in conformance with Maine Hazardous Waste, Septage and Solid Waste Management Act, 38 M.R.S.A. Sections 1301 *et seq.*
- (20) Disturbance of vegetation must be avoided, if possible. Where vegetation is disturbed outside of the area covered by any road or structure construction, it must be reestablished immediately upon completion of the activity and must be maintained.
- (21) A vegetated area at least 25 feet wide must be established and maintained between any new stormwater outfall structure and the high water line of any open water body. A velocity reducing structure must be constructed at the outlet of the stormwater outfall that will create sheet flow of stormwater, and prevent erosion of soil within the vegetated buffer. If the 25 foot vegetated buffer is not practicable, the applicant must explain the reason for a lesser setback in writing. Approval from the DEP must be in writing and any recommendations must be incorporated into the activity.

C. Definitions. The following terms, as used in this chapter, have the following meanings, unless the context indicates otherwise:

- (1) Diversion. The rerouting of a river, stream or brook around a construction site and then back to the downstream channel.
- (2) Fill. a. (verb) To put into or upon, supply to, or allow to enter a water body or wetland any earth, rock, gravel, sand, silt, clay, peat, or debris; b. (noun) Material, other than structures, placed in or immediately adjacent to a wetland or water body.
- (3) Floodplain wetlands. Freshwater wetlands that are inundated with flood water during a 100-year flood event based on flood insurance maps produced by the Federal Emergency Agency or other site specific information.
- (4) Riprap. Heavy, irregularly shaped rocks that are fit into place, without mortar, on a slope as defined in the MaineDOT Standard Specifications, dated **November 2014**.



Environmental Summary Sheet

WIN: 018964.00

Date Submitted: 5/23/19

Town: Gardiner

CPD Team Leader: Kristen Chamberlain

ENV Field Contact: Val Derosier

NEPA Complete: Not applicable. No FHWA funds.

Section 106
PA
Section 106 Resources: None

Section 4(f) and 6(f)
Section 4(f)
Review Complete- No USDOT \$
Section 6(f)
Not Applicable

Maine Department of Inland Fisheries and Wildlife Essential Habitat
Not Applicable
Timing Window: Not Applicable

Section 7
Species of Concern: Atlantic salmon, Shortnose sturgeon, Atlantic sturgeon-NLAA
ATS Critical Habitat-Likely to Adversely Affect
Comments/References: ACOE Lead Formal Section 7 consultation with NMFS.
Special Conditions apply. See Special Provision 105.
Species of Concern: Northern Long-Eared Bat-may affect
Comments/References: 4d consultation; ACOE Lead

Essential Fish Habitat
Minimal Adverse Effect -ACOE Lead through permit process.

Maine Department of Conservation/Public Lands, Submerged Land Lease
Not Applicable

Maine Land Use Regulation Commission
Not applicable

Maine Department of Environmental Protection
Permit by Rule (PBR)

*Applicable Standards and Permits are included with the contract

Army Corps of Engineers, Section 10 of the Rivers and Harbors Act and Section 404 of the Clean Water Act.
Category 2
-Work Start Notification Form and Compliance Certification Form must be completed by the Resident and/or ENV Field Contact and submitted to the Corps with copy to Kristen Chamberlain
-In-water work: October 1-April 9
-Post project completion report within 4 weeks of project completion (ENV Biologist and Field Contact)
-Post construction monitoring for fish passage conditions (depths and velocities and invert and outlet).
-Special Conditions apply. See Special Provision 105.

*Applicable Standards and Permits are included with the contract

Stormwater Review
N/A

Special Provisions Required
Special Provision 105-Timing of Work Restriction N/A [] Applicable [x]
Special Provision 656-Minor Soil Disturbance N/A [] Applicable []
Standard Specification 656-Erosion Control Plan N/A [] Applicable [x]
Special Provision 203-Dredge Spec N/A [] Applicable [x]
General Note for Hazardous Waste N/A [x] Applicable []
Special Provision 203-Hazardous Waste N/A [x] Applicable []
Special Provision 105.9 N/A [x] Applicable []

*All permits and approvals based on plans/scope as of: 11/2017