

Introduction to Mayser and Anti-Pinch

- Mayser is a worldwide leader in providing pinch protection to the automotive, industrial, and public transportation sectors
 - Mayser has over 40 years of extensive experience in producing anti-pinch technology that has consistently performed in the harshest climates, such as Canada, Finland and Norway with almost no maintenance required
 - Most passenger train and transit buses worldwide are equipped with obstruction detection, except for school buses
 - Mayser specializes in providing “anti-drag” solutions, the safest variation of pinch protection for public transportation vehicles, which can detect objects as small as a backpack strap or dog leash

MAYSER®

Why is it important?

Real Life Incidents

Kindergartner killed by school bus was dragged nearly 300 feet before being run over: report

By [Jordan Gartner](#)

Published: Jan. 9, 2026 at 9:47 PM EST | Updated: Jan. 9, 2026 at 9:49 PM EST



- 5-year-old kindergarten student Simon Gonzalez was boarding the school bus in Maine when the doors were closed on his arm
- The bus driver was unaware of Simon being stuck in the door and began driving the school bus for over 300 feet before Simon was eventually freed from the door
- Unfortunately, Simon did not survive his injuries

Why is it important?

Real Life Incidents

7-year-old boy dragged by school bus after backpack strap gets stuck in door

By Chris Williams | Updated May 15, 2022 3:15pm CDT | News | FOX TV Digital Team | [➔](#)

- Athena Lavigne's 7-year-old son was exiting the school bus after kindergarten class in Maine, and his backpack became stuck in the door as the driver drove away.
- Athena ran after the bus as she watched her child being dragged down the road.
- After 600 feet of being stuck outside the door, the vehicle stopped, and her son was freed from the bus doors.
- Athena's son suffered road rash but otherwise was ok physically.
- After the incident, Athena's kids no longer feel comfortable riding the school bus and now finds different modes of transportation to go to school.



- 6-year-old Ally Rednour was a special needs child who was dragged by a school bus in 2015.
- Ally's backpack was caught in the school bus door for around 60 seconds.
- She had to undergo several surgeries due to the abrasions she suffered while being stuck in the door. Ally still endures anxiety just from the sight or sound of a bus
- The school district (JCPS) had to pay a large settlement to the family for approximately \$5 million.

Why is it important?

Real Life Incidents

Girl killed in western Mass. bus dragging incident

By [Travis Andersen](#) Globe Staff, October 29, 2016, 1:12 a.m.



Child dragged alongside bus after backpack gets caught in door, leaving mom furious

by: [Sean McDowell](#)

Posted: Apr 15, 2016 / 07:35 PM CDT

Updated: Apr 15, 2016 / 07:35 PM CDT

Utah school district settles with family of biracial boy who was dragged by a school bus

By Pierre Melhan, CNN

© 2 minute read · Published 1:07 AM EDT, Fri July 19, 2019

By **Inside Edition**

Updated: 12:41 PM PST, December 11, 2015

First Published: 4:00 PM PST, December 10, 2015



After the incident in North Carolina, INSIDE EDITION takes a look at the potential dangers of school buses.

A six-year-old girl was dragged for nearly a mile in North Carolina when her arm got caught in her [school bus](#) door.

Why is it important?

Real Life Incidents

NEWS

Indiana 7-year-old dragged down street by school bus

by: Max Lewis
Posted: Apr 11, 2023 / 08:45 AM EDT
Updated: Apr 11, 2023 / 10:32 AM EDT

Canadian Child Dragged by School Bus

By Merari Acevedo-Vigo November 22, 2022

Vidalia child dragged by school bus while getting off

Published 4:27 pm Wednesday, June 30, 2021

By Sabrina Simms Robertson

Child in Norfolk County dragged by school bus after getting stuck between doors

Posted: November 21, 2022 | 8:46 PM · By: Alex Last

Auburn student dragged by school bus after getting arm caught in door

by Katie Sampson, WGME | Sat, October 1st 2022 at 8:39 PM
Updated Mon, October 3rd 2022 at 6:46 AM



Dothan school bus drags child down the road, driver arrested, police

by: Richard Everett
Posted: Dec 10, 2024 / 09:46 AM CST

Anti-Pinch Regulations

- Transit buses uses a test specimen to determine if a door system qualifies as anti-pinch
- The most used transit bus regulation for obstruction detection in the United States is California Code of Regulations Tit. 13, § 1267 - Bus Entrances and Exits
 - The regulation states “Door shall release when the door closes on an object as small a ½ inch diameter smooth cylinder held perpendicular to the plane of the door opening at any point where the door halves meet
- Mayser’s recommends that the state of Maine adopts the California Code of Regulations Tit. 12 § 1267 door obstruction regulation for their school buses
 - This will ensure the safest anti-pinch solutions will be supplied to your school buses, simulating the detection of an object approximately the size of a finger
- The original Maine school bus anti-pinch regulation did not include a test specimen
 - Some solutions provided by school bus OEMs that “pass” the original regulation are not real pinch protection solutions



Mayser samples being tested on an IC Bus door system.

-Green light indicates sensors are actuated by the 4mm (.15 inch) test specimen

How do pinch sensors work?

MAYSER[®]

- The door controller reads constant resistance from sensors
 - Once the sensor is actuated, resistance drops below a certain threshold to indicate a pinch has occurred
 - If sensor was to be damaged, resistance would increase infinitely and notify the vehicle
 - Sensors remain on after the door closes to ensure max protection, adjustable based on customer preference
- Sensors can be programmed to an audible alarm, reopen the doors, a visual alert, message to the driver dashboard, etc.
 - For a retrofit, the options are limited. Currently planning on an audible alarm and the de-powering of the doors



Anti Pinch Videos



- A half inch rod test specimen in a Blue Bird bus

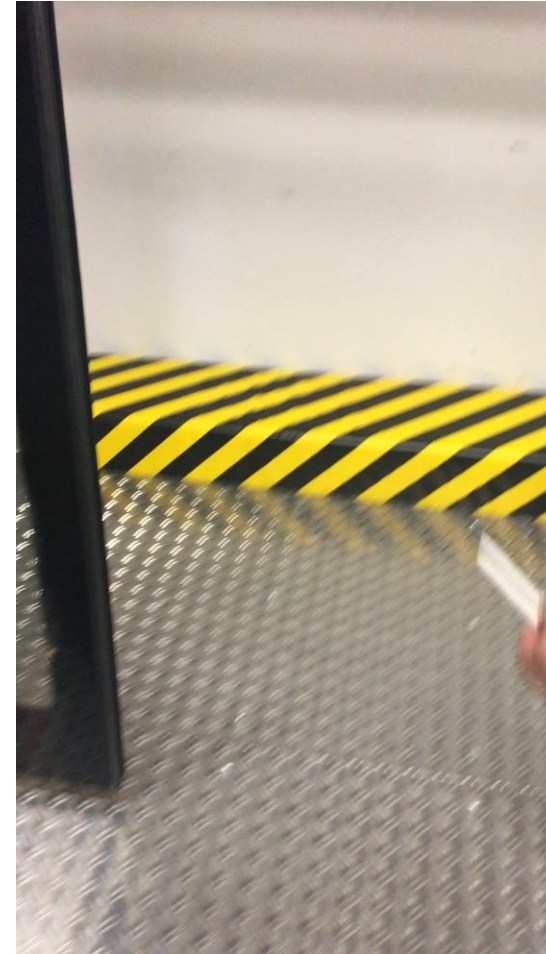

- A finger test specimen used on a transit door system

Anti-Drag

- Anti-drag protection is an improved version of anti-pinch by preventing the possibility of dragging through detection of the smallest obstructions
 - With the increased responsibility of preventing dragging incidents from occurring, it is harder to comply to the standards of anti-drag
- Anti-drag has become highly mandated on both transit buses and rail vehicles in Europe according to the specification EN 14752:2024.
 - It has recently become more common in the United States as well for public transportation agencies to request anti-drag detection from their door suppliers when requesting bids.
- To pass the dynamic anti-drag test, a test specimen, shown in the top image to the right, is required to be pulled in 7 different directions, shown in the bottom image

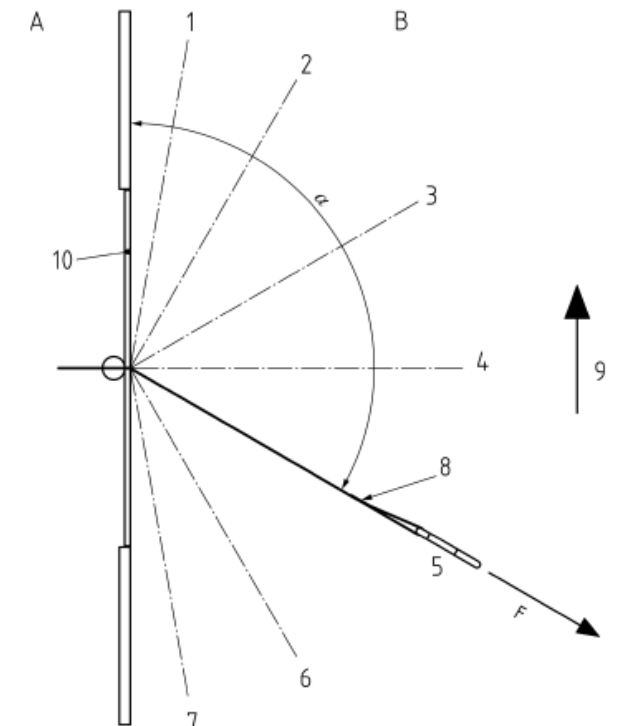

Key

- | | | |
|-------------------------------------|----------------------------|----------------------------|
| 1 Pulling direction (10°) | 4 Pulling direction (90°) | 7 Pulling direction (170°) |
| 2 Pulling direction (30°) | 5 Pulling direction (120°) | 8 Test object |
| 3 Pulling direction (60°) | 6 Pulling direction (150°) | 9 Direction of motion |
| α Angle of the pulling force | | |

Figure 20 — Test procedure for dynamic anti drag

Drag Detection Demo Videos

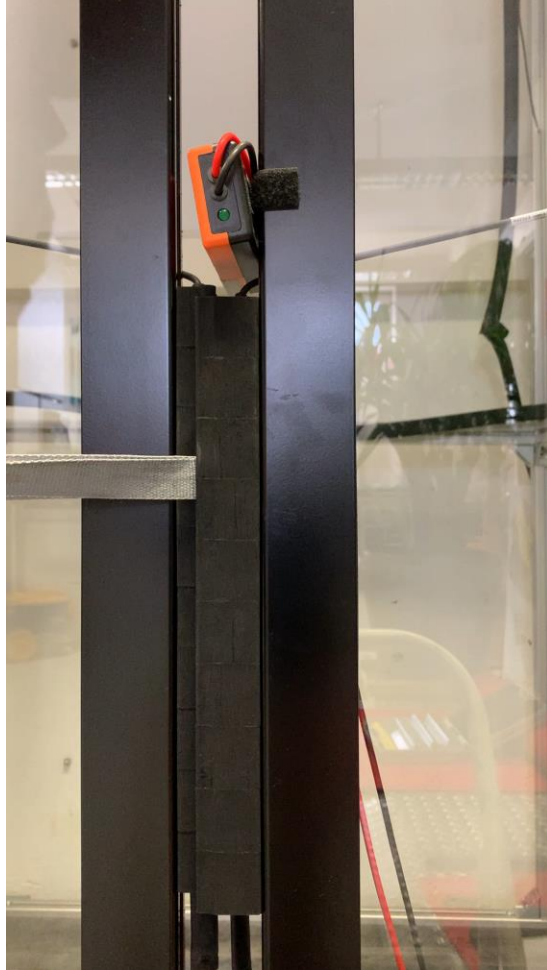

Lanyard anti-drag test

- Simulates a backpack strap obstructed in doorway
- Example of how an anti-drag test would be conducted according to EN14752:2024
- Green light in adjacent photos indicates sensor is being actuated

- A lanyard being used to test “anti-drag” compliance on an IC Bus door

Developing Solutions

MAYSER[®]

- Mayser has partnered with Blue Bird and our solution is currently being used on 2025 Blue Bird buses to comply with the original regulation and has gained field experience in the last 6+ months
 - Working on developing a control unit solution as the door seal design has already been manufactured
- The bus dealers for IC Bus and Thomas Built Bus has reached out to Mayser to help develop a solution for this new regulation
 - Mayser is currently working on a preliminary door seal and control unit design with both bus dealers
 - Mayser is planning on working very closely with the dealers to help as much as possible to develop a proper wiring solution to make installation as easy as possible
- Mayser's designs are specific per school bus OEM, and no other school bus designs are being worked on currently (i.e., Micro Bird, Collins Bus, etc.)

Timeline

MAYSER[®]

- Mayser is proposing that the anti-pinch portion of the regulation goes into effect at the beginning of the 2027/2028 school year
 - This gives the essential amount of time for all parties involved to develop proper solutions and designs without compromising school buses in the field
- Mayser can begin manufacturing production parts in the following time frames:
 - Blue Bird production parts can begin manufacturing in Q3/Q4 of 2026
 - IC Bus production parts can be manufactured in Q4 2026 to Q2 2027
 - Thomas Built Buses production parts can be manufactured in Q4 2026 to Q2 2027

Next Steps

- Will manual doors be included in this regulation or will they be omitted?
- Would you like Mayser to show a live demo on a Blue Bird bus to show how it works on a vehicle in the field?
- What can Mayser do to support further?
- Any questions?

A background image of a city skyline rendered in white wireframe lines against a light blue gradient sky. The buildings are of various heights and are arranged in a perspective view.

MAYSER[®]

Thank you very much!

Andrew Wiseman

Sales Engineer

Andrew.wiseman@mayser.com

M: 734-644-2142