



TM

**Performance Testing and Evaluation Certification Report**

Baylor University  
Department of Environmental Studies  
Individual On-Site Waste Water Treatment System  
Testing and Certification Program  
on the

**Aqua Aire 500**  
**With Model Series 600, 750, 1000, and 1500**

Manufactured by Ecological Tanks, Inc.  
Downsville, Louisiana, U.S.A.

**Original Report: May 2, 2002**

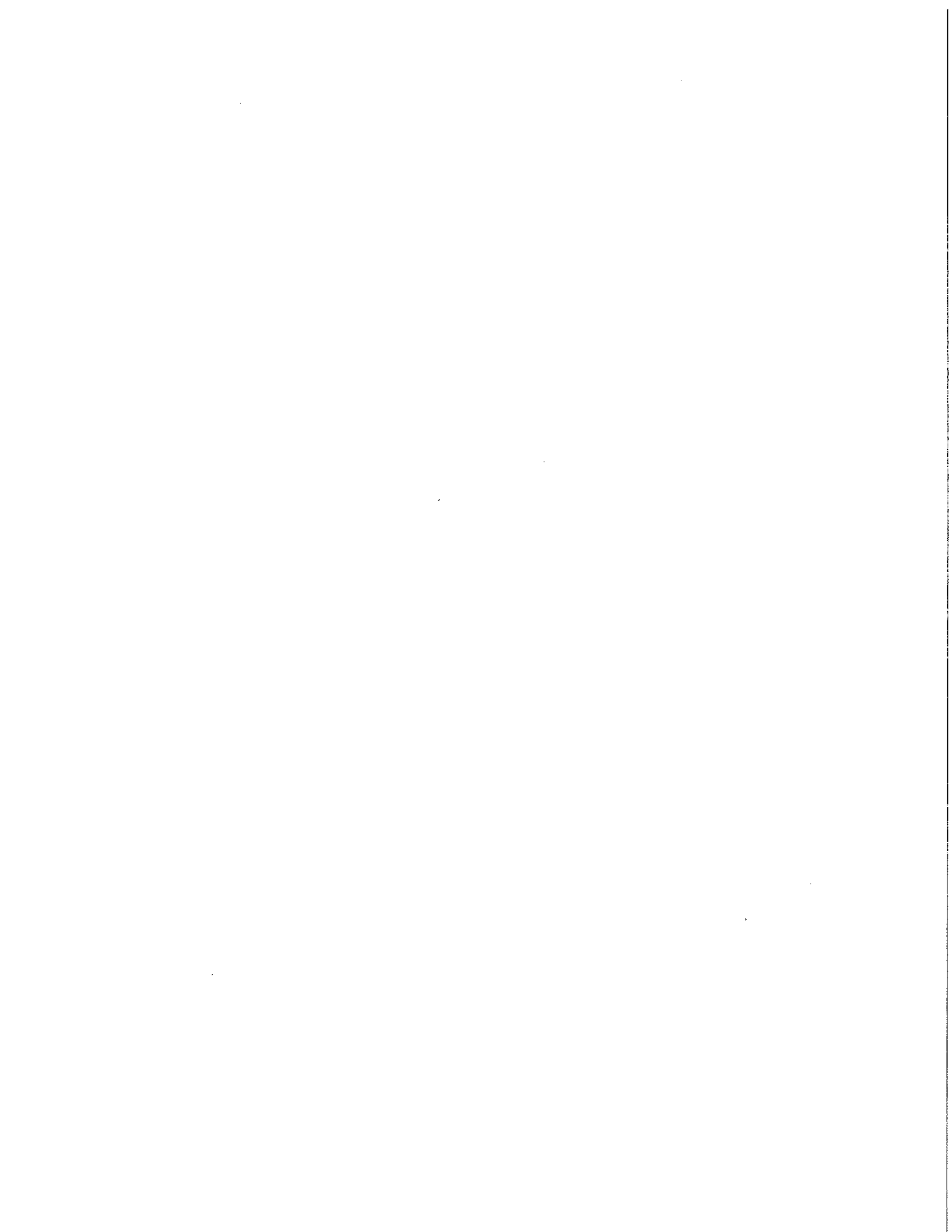

## WATER TEST PERFORMANCE EVALUATION REPORT

The Baylor University, Department of Environmental Studies, Individual On-Site Waste Water Treatment System Testing and Certification Program has determined by a thorough performance evaluation under the provisions of the NSF/ANSI Standard 40, 2000, that the residential wastewater treatment system Aqua Aire 500, manufactured by Ecological Tanks, Inc., of Downsville, Louisiana, USA has successfully fulfilled all the requirements of NSF/ANSI Standard 40, 2000, and has achieved effluent water quality consistent with a Class I effluent residential wastewater treatment system.

All tests were performed at the Waco Metropolitan Area Regional Sewerage System Treatment Plant (WMARSS), Waco, Texas operated by the Brazos River Authority (BRA). Laboratory analysis of samples, including CBOD, TSS, and VSS were conducted at the BRA Laboratory by BRA personnel. Affidavits regarding non-involvement of all Baylor Staff and BRA Staff and laboratory personnel are on file. Characteristics of the raw influent sewage are included in the tabulated data of this report.

The observations and analyses included in this report are certified to be correct and detailed descriptions and analyses are described herein. Additional information about the testing agency, test site, equipment, data collection procedures, QA/QC protocols, etc. is provided to State environmental regulatory authorities under separate cover.

The certified data is the property of the manufacturer of the residential wastewater treatment system and can be released only with the manufacturer's permission. The manufacturer has agreed to present the data in this certification in its entirety whenever it is used in advertising, prospective, bids, or similar uses.

I certify that the attached document is an official report issued by the Baylor University Individual On-Site Waste Water Treatment System Testing and Certification Program. The original of this document is neither a public record nor a publicly recordable document. The original bench data is retained in the files of Baylor University.

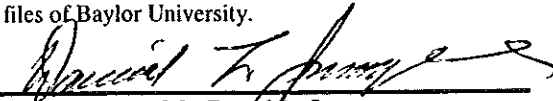
  
Mr. David L. Jumper

Signed before me this 9<sup>th</sup> day of April, 2003.

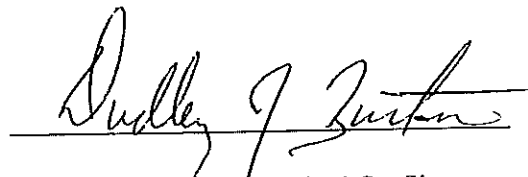

Project Director, Individual On-Site  
Waste Water Treatment System  
Testing and Certification Program  
Department of Environmental Studies  
P. O. Box 97261  
Baylor University, Waco, Texas. 76798-7261  
Phone: (254) 710-3405 Fax: (254) 710-3409

Date: 2 May, 02

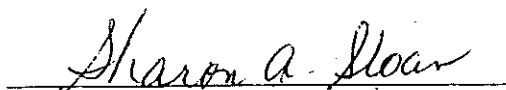
  
Sharon A. Sloan  
My commission expires: Sept. 7, 2003

This Page is Intentionally Left Blank

## PREFACE

This report describes the results of the performance evaluation conducted by the Baylor University, Department of Environmental Studies, Individual On-Site Waste Water Treatment System Testing and Certification Program, Waco, Texas, with the cooperation of the Brazos River Authority, Waco, Texas, on the residential wastewater treatment system Aqua Aire, 500 GPD manufactured by Ecological Tanks, Inc., in Downsville, Louisiana.

All laboratory tests were performed at the Waco Metropolitan Area Regional Sewerage System Treatment plant (WMARSS) operated by the Brazos River Authority (BRA). In-situ tests and sample collection were performed by Baylor Personnel. All statistical analysis was performed by using Microsoft Excel 5.0. Statistical summaries are included in Appendix A.

This report contains results of the testing protocol, a description of the residential wastewater treatment system, its operation and key process control equipment, and a narrative summary of the test program, including test location, procedures and significant occurrences.

The purpose of this evaluation is to determine the efficacy of the Aqua Aire 500 gpd residential wastewater treatment system for distribution and design application. All phases of this evaluation were conducted in accordance with the provisions and specifications set forth by NSF International in the NSF/ANSI Standard 40, 2000 for residential wastewater treatment systems capable of producing Class I effluent.

### NSF/ANSI Standard 40, 2000

Performance evaluation of residential wastewater treatment systems is achieved within the provisions of NSF/ANSI Standard 40, 2000 prepared by the NSF Joint Committee on special Processes or Devices used in Treating Wastewater and adopted by the NSF Board of Trustees, and adopted by the Baylor University Individual On-Site Waste Water Treatment System Testing and Certification Program.

The standard is consistent with the methodology established by NSF International in the development of standards and criteria for special equipment having a bearing on public health and/or the environment. It provides for uniformity of requirements and interpretation applicable to processes intended to treat wastewater from individual homes and other sources having similar types and volumes of liquid wastes.

There are five fundamental principles which relate to application of the standard:

- a. The standard represents minimum and basic requirements for evaluation.
- b. Performance evaluation is independent of design and construction although the evaluation recognizes structural weaknesses, undesirable noise, and other detriments to the environment as part of the test results.
- c. Installation and operation of the equipment is performed according to the instructions of the manufacturer consistent with actual field installation and use.

- d. Appropriate warranties and service provisions must support field applications of the equipment to enable continuous operation within the demonstrated performance characteristics of the residential wastewater treatment system or process.
- e. Sample collection, preservation and storage, and analytical methods by the testing agency are in accordance with Standard Methods for the Examination of Water and Wastewater, Eighteenth Edition, and Manual of Methods for Chemical Analysis of Water and Wastes, when applicable, and the data produced is certified as a true and accurate record of performance under the known conditions of the test.

Conformance with the standard is not to be construed as a blanket guarantee of the equipment in all applications. Rather it is a certification that the residential wastewater treatment system was appropriately tested and that if the residential wastewater treatment system is manufactured, installed and maintained as it was tested, documented as reported here in and maintained as required by the manufacturer, it will usually produce water quality in accordance with the standard.

Residential wastewater treatment systems conforming to NSF/ANSI Standard 40, 2000 are classified as Class I or Class II residential wastewater treatment systems according to the quality of effluent produced by the residential wastewater treatment systems during their performance evaluation. Class I residential wastewater treatment systems must also demonstrate performance consistent with the odor, oily film and foam requirements of the standard. With the 1978 revision of the standard, Class I residential wastewater treatment systems must satisfy requirements of the EPA's Secondary Treatment Guidelines for five day biochemical oxygen demand, suspended solids and pH quality requirements.

### PERFORMANCE EVALUATION

This report is applicable to the residential wastewater treatment system manufactured by Ecological Tanks, Inc., of Downsville, Louisiana, U.S.A and referred to as the Aqua Aire. This residential wastewater treatment system is marketed as a complete home aerobic treatment system and has a rated capacity of 500 gallons per day. This residential wastewater treatment system represented by the drawings and specifications included as Appendix D.

NSF/ANSI Standard 40, 2000 delineates a standard method for the performance evaluation of residential wastewater treatment systems. A copy of the NSF/ANSI Standard 40, 2000 can be ordered by writing to:

NSF International  
3475 Plymouth Road  
PO Box 130140  
Ann Arbor, Michigan 48113-0140

Sampling points and their associated analytical parameters are outlined in Table I. The samples were collected five days per week which exceeds the NSF/ANSI Standard 40, 2000 guidelines, to produce a more accurate representation of the residential wastewater treatment system's performance. Composite samples of the effluent were taken daily, proportional to the flow, by an automatic sampler activated by a timer synchronized with the dosing timer. All other samples were grab samples, or the measurements were made in-situ.

**TABLE 1 SAMPLING SCHEDULE**

	DO	CBOD	TSS/V SS	pH	Temp.	Sett. Sol.	Color	Odor	Oily Film	Foam
Influent	I	C	C	I	I					
Aeration Chamber	I		G	G	I	G				
Effluent	I	C	C	I	I		G	G	G	G

G = GRAB SAMPLE      C = COMPOSITE SAMPLE      I = IN SITU MEASUREMENT

Shown in Table II is a statistical summary of the numerous observations for each analytical parameter, expressed in terms of the median, minimum and maximum values, and the interquartile range for each parameter. The median and interquartile range indicate, respectively, the central tendency and variability of the parameter in a manner that is free from assumptions with regard to the overall distribution of data.

---

This Space Intentionally Left Blank

**TABLE II. SUMMARY OF PERFORMANCE DATA**

		MEDIAN	MINIMUM	MAXIMUM	INTERQUARTILE RANGE
Dissolved Oxygen (mg/l)	aeration	1.29	.08	28.62	.65-6.82
	effluent	1.85	.09	13.63	.75-5.92
Temperature (C)	influent	21.75	8.39	31.65	18.39-25.84
	aeration	21.73	15.22	32.42	17.38-26.08
	effluent	20.54	6.33	32.49	16.47-25.23
pH	influent	7.37	6.09	8.96	7.05-7.65
	aeration	7.86	7.15	9.18	7.63-8.17
	effluent	7.86	7.01	9.30	7.56-8.07
5 day Biochemical Oxygen Demand (mg/l)	influent	108	7.83	1071	75.0-222.5
	effluent	2.0	2.0	14	2.0-2.153
Suspended Solids (mg/l)	influent	124	44	1560	78-226.5
	aeration	2116	106	3825	990-2496
	effluent	2.2	.60	288.0	1.4-3.95
Settleable Solids (ml/l) 45-min..	aeration chamber	12.0	0.0	55.0	5.0-17.0

**Median:** Fifty percent of the values are less than or equal to this value.

**Interquartile Range:** The range of variability about the median which is sufficient to contain 50% of the observations. The interquartile range lies between the upper and lower 25% of the observations.

Table III summarizes the effluent five day biochemical oxygen demand (CBOD<sub>5</sub>) and suspended solids measurements, which demonstrated a level of performance by the Aqua Aire residential wastewater treatment system consistent with the Class I effluent requirements of NSF/ANSI Standard 40, 2000.

**TABLE III. EFFLUENT QUALITY SUMMARY**

Parameter	Number of Observations	Minimum	Maximum	Median	Interquartile Range	Confidence Limit 90%
CBOD mg/L	141	2.0	14.0	2.0	2.0-2.15	2.0-6.60
Suspended Solids	139	.6	32.5	2.2	1.4-3.95	.8-12.18

Table IV presents removal efficiencies calculated from the mean influent and effluent values, the mean values being more conventional indicators of overall efficiency.

**TABLE IV. REMOVAL EFFICIENCIES**

Parameter	Influent Mean	Effluent Mean	Reduction	% Reduction
CBOD	169.73	2.684	167.05	98.4
Suspended Solids	183.97	3.925	180.05	97.9

Table V represents the analytical results performed to determine the quality of the effluent.

**TABLE V. EFFLUENT QUALITY ANALYSIS**

TSS Inf.	CB.D	Eff. CBOD 30-day Mean (mg/L)	Eff. TSS 30-day Mean (mg/L)	Eff. CBOD 7-day Mean (mg/L)	Eff. TSS 7-day Mean (mg/L)	CBOD Reduction 30-day (%)	TSS Reduction 30-day (%)
	Minimum	2.114	2.22	2.0	1.11	97.6	97.4
	Maximum	3.66	6.93	6.56	13.44	98.8	97.7
	Median	2.89	4.43	2.17	2.80	98.2	97.2

## ANALYTICAL RESULTS

During the 26 weeks of operation, the Aqua Aire residential wastewater treatment system produced a treated effluent quality consistent with the Class I requirement. Based on a 500 gallon per day flow, the Aqua Aire maintained an average CBOD<sub>5</sub> effluent of 2.684 mg/L and suspended solids of 3.925 mg/L. On a 90 percentile basis, the residential wastewater treatment system performed with CBOD<sub>5</sub> effluent between 2.0 and 6.6 mg/l and suspended solids between .8 and 12.18 mg/l. The samples were taken in accordance with and complied to the requirements of the NSF/ANSI Standard 40, 2000 guidelines. The laboratory results summarized and presented in Table II are described herein as follows:

### BIOCHEMICAL OXYGEN DEMAND (CBOD<sub>5</sub>)

#### A. INFLUENT

Based on >140 observations, the range of CBOD<sub>5</sub> values was 7.83 to 1071 mg/L. The median value was 108 mg/L with 50 percent of the values in the range from 75 to 222.5 mg/L.

#### B. AQUA AIRE RESIDENTIAL WASTEWATER TREATMENT SYSTEM EFFLUENT

CBOD<sub>5</sub>, determined in 141 observations, ranged from a minimum value of 2.0 mg/L to a maximum value of 14 mg/L with a median value of 2.0 mg/L. The interquartile range of values, i.e., the range of variability about the median that lies between the upper and lower 25 percent of the observations, was 2.0 to 2.153 mg/L. The effluent quality summary, as shown in Table III, indicates that at least 90 percent of the samples had values greater than 2.0 and less than 6.6 mg/L. The analysis performed on the quality of the effluent, as demonstrated in Table V, indicates that the arithmetic mean of all effluent samples collected in a period of 30 consecutive sampling days has a maximum value of 3.66 mg/L. The arithmetic mean for all effluent samples collected in a period of 7 consecutive sampling days has a maximum value of 6.56 mg/L. The analysis indicates that the average reduction for CBOD<sub>5</sub> is 98 %. The values used in determining removal efficiency are presented in Table IV.

### SUSPENDED SOLIDS

#### A. INFLUENT

The values for suspended solids in the residential wastewater treatment system influent ranged from a minimum of 44 mg/L and a maximum value of 1560 mg/L. The interquartile range of values was between 78 and 226.5 mg/L which bounded a median value of 124 mg/L.

**B. AQUA AIRE RESIDENTIAL WASTEWATER TREATMENT SYSTEM EFFLUENT**

A median value of 2.2 mg/L was established for effluent suspended solids, based upon > 140 observations. The interquartile range was between 1.4 and 3.95 mg/L with 90 percent of the values being greater than .8 and less than 12.18 mg/L. Table III displays the effluent quality summary while Table IV shows the removal efficiencies of CBOD<sub>5</sub> and SS. As shown in Table V, the maximum value for the effluent suspended solids is 6.93 mg/L, and the maximum value for the 7-day mean of effluent suspended solids is 13.44 mg/L. Also demonstrated in Table V, the effluent does satisfy the suspended solids criteria set forth by NSF/ANSI Standard 40, 2000, following EPA's Secondary Treatment Guidelines for Class I.

Table IV presents the mean influent and effluent suspended solids values used to calculate percent reduction accomplished by this residential wastewater treatment system which was greater than 97.9 % removal of suspended solids.

**AERATION CHAMBER SUSPENDED SOLIDS**

The concentration of suspended solids in the aeration chamber ranged from a minimum value of 106 mg/L to a maximum value of 3825 mg/L, with a median of 2116 mg/L. The range of variability about the median which contains fifty percent of the observations ranged from 990 to 2496 mg/L. During the test period, aeration chamber suspended solids concentration did not vary in any consistent or predictable manner with respect to time.

**DISSOLVED OXYGEN (D.O.)**

**A. AERATION CHAMBER**

The Aqua Aire system demonstrated the capacity to maintain an aerobic environment in the aeration tank contents. The minimum value for dissolved oxygen was .08 mg/L with a median of 1.29 mg/L and an interquartile range of .65 to 6.82 mg/L.

**B. AQUA AIRE RESIDENTIAL WASTEWATER TREATMENT SYSTEM EFFLUENT**

A median of 1.85 mg/L D.O. was obtained based on determinations of effluent dissolved oxygen. The minimum value recorded for dissolved oxygen was .09 mg/L with an interquartile range of .75 to 5.92 mg/L.

**COLOR, THRESHOLD ODOR, OILY FILM, FOAM**

NSF/ANSI Standard 40, 2000 specifies limits for Class I effluent with respect to color, threshold odor, oily film, and foam. Special attention was devoted to these parameters each sampling day as well as several random checks throughout the 26 weeks, including weekends. Aqua Aire residential wastewater treatment system effluent was within limits specified in NSF/ANSI Standard 40, 2000:

1. Effluent color was less than 15 units
2. Threshold Odor - non-offensive
3. There was no evidence of oily film or foam.

## NOISE

Noise level measurements were taken in accordance with NSF/ANSI Standard 40, 2000 and LSC, Chapter 13 Section A,6.4.2:(t). The measured level, including background noise, was within the limits of the NSF/ANSI Standard 40, 2000 and the LSC.

## STRESS TESTING

Stress loading of the Aqua Aire was conducted as shown by the shaded data in Appendix C and is designed to evaluate residential wastewater treatment system capabilities and performance under simulated use conditions of wash day loading, working mother loading, equipment or power failure, and return from nine days vacation with the typical attendant shock loading. As can be seen from the results depicted in Table IV for effluent five day Biochemical Oxygen Demand (CBOD<sub>5</sub>) and for effluent Suspended Solids, the performance of Aqua Aire was consistent with the effluent quality requirements of NSF/ANSI Standard 40, 2000 protocol contained in this document. During the seven day period immediately following each stress condition, the effluent values did remain within the limits of Class I effluent quality.

## TRASH TRAP ISSUE

The issue of a trash trap requires further comment. The Baylor test typically involves running the residential wastewater treatment system without pretreatment (no trash trap) and, typically, without post-treatment. The goal of the test is to evaluate the capacity of the residential wastewater treatment system to treat the incoming wastewater in its most severe condition. Systems which employ pre-treatment chambers typically are fitted by the manufacturer with a pass-through pipe in order to by-pass the compartment for the test. The AA500T was tested without a trash trap in operation.

Residential wastewater treatment systems are not tested with a trash trap for several reasons:

1. The CBOD strength and low dissolved oxygen levels of the influent sewage means that a portion of the aerobic bacteria are killed in the (septic) trash trap. Therefore, normal floc formation indicative of a residential environment is seriously delayed.
2. Influent water is already coarse filtered to remove non biodegradable materials because these would cause problems for dosing pumps and valves. Such pumps and valves would not normally be put in a residential installation. However, they are necessary for the test to control influent rates and times.
3. A trash trap will provide some reduction of CBOD and TSS. The amount depends on the size of trash trap used. However, operating the test without a trash trap provides a "worst case scenario."

Some states require the use of a trash trap, independent of this test. Baylor recommends strongly the use of a trash trap, especially in all cases where a garbage disposal is being used or may be used. A minimum recommended size for a trash trap is half the daily rated capacity of the residential wastewater treatment system. An absolute minimum size is 1/4 of the residential wastewater treatment systems daily rated capacity. This recommendation

time (several years) to minimize pumping requirements. However, this size is also small enough not to interfere substantially with the aerobic performance of the residential wastewater treatment system or to raise costs excessively. For purposes of the residential wastewater treatment system certification, a trash trap is treated as an approved "upgrade."

Systems which employ a pretreatment chamber as an integral part of system design configuration because of cast mold strategies or other considerations, but were not tested with the pretreatment chamber activated, should not be installed with additional pretreatment tankage, if the added volumetric capacity represented by the additional tankage would increase the total net pretreatment volume beyond one-half of the daily rated treatment capacity of the tested or Model Series System.

## SUMMARY

Overall, the Aqua Aire residential wastewater treatment system performed admirably during this extended test and under a wide variety of operating conditions. There were no repairs or maintenance work done on the residential wastewater treatment system during the test period. During the course of the test, the basic flow system and residential wastewater treatment system operations were stable and consistent.

---

This Space Intentionally Left Blank

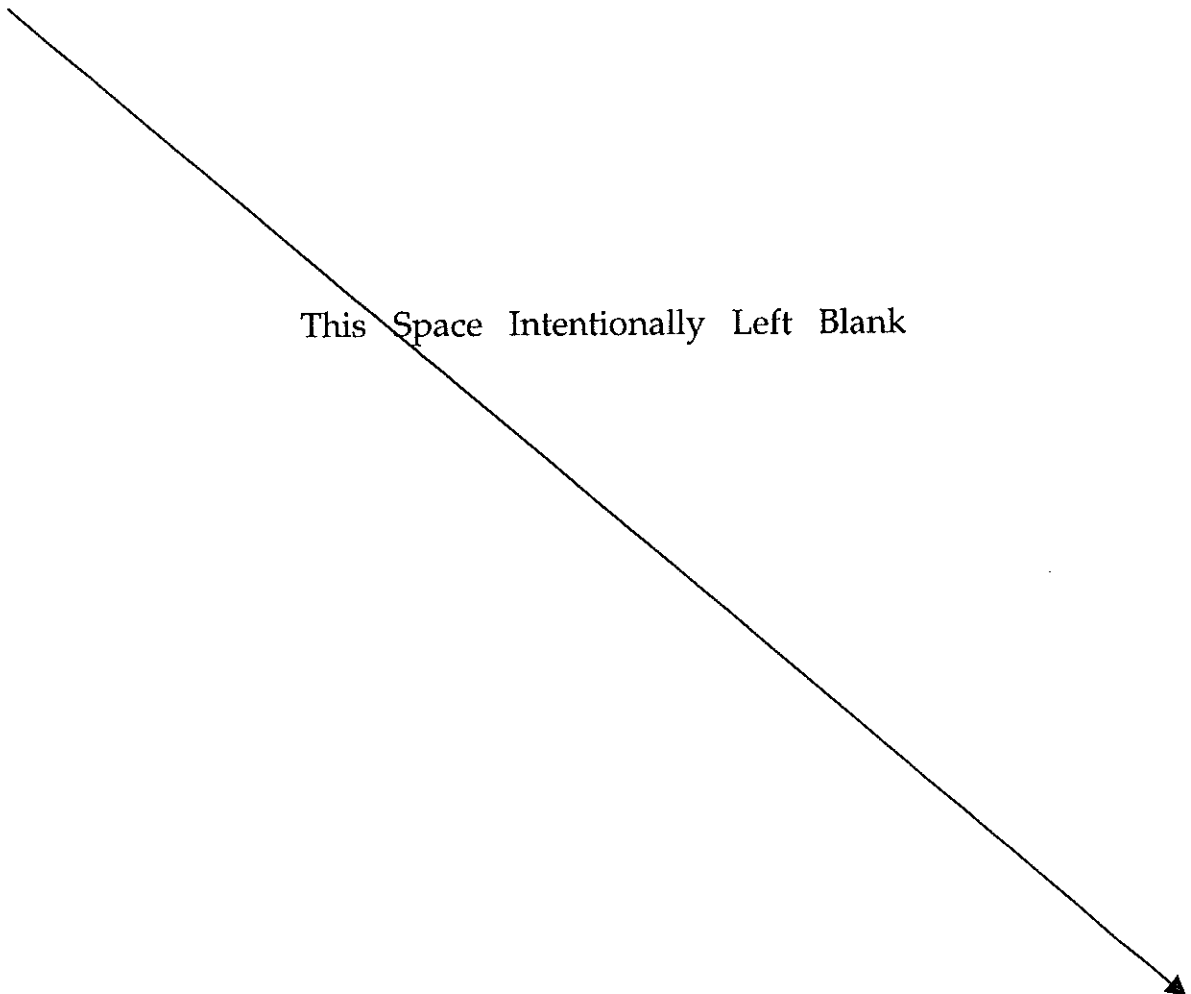

This Page Intentionally Left Blank

# **APPENDIX A**

## **STATISTICAL SUMMARIES**

This Page Intentionally Left Blank

Aqua Aire Statistical Summaries

DO effluent	DO aeration	Temp influent	Temp aeration	Temp effluent	pH influent	pH aeration	pH effluent	CBOD influent	CBOD effluent	7-day avg	30-day avg	TSS influent	TSS aeration	TSS effluent	7-day avg	30-day avg	VSS Inf (%)	VSS aeration	VSS effluent	SS 45 m	Dosing CPD
2.35	0.26	31.4	32.2	32.25	7.52	7.74	7.83	861	2	2	2	158	645	645	2	2	78	470	1.8	8	500
2.45	0.85	31	31.8	32.36	7.5	7.81	7.82	148	2	2	2	122	1000	1.6	1.8	2	75	690	1.4	7	500
2.69	3.02	31.35	32.41	32.4	7.74	7.86	7.87	149	2	2	2	94	945	1.8	1.8	2	76	665	1.2	6	500
3.68	5.22	31.25	32.42	32.03	7.12	8.03	7.94	127	2.45	2	2	132	895	1	1	2	85	635	1	6	500
3.03	0.32	31.22	32.38	32.43	7.23	7.68	7.8	122	2	2	2	138	860	1.5	1.5	2	74	950	1.5	4	500
3.63	0.38	31.41	32.33	32.21	7.57	7.74	7.87	82	2	2	2	74	785	3.75	3.75	2	81	540	2.5	4	500
2.72	0.84	31.46	32.42	32.2	7.31	7.86	7.91	61	2	2.064	2	66	865	3	3	2.093	76	535	1.2	4	500
2.07	1.76	31.64	32.39	32.49	7.67	7.77	7.96	94	2	2.064	2	73	895	1	1	1.950	84	640	0.8	3	500
2.97	6.34	31.64	32.26	31.95	7.67	8.07	7.93	85	2	2.064	2	70	830	2	2	2.007	79	545	1.75	3	500
3.33	6.89	31.28	32.08	31.48	7.66	8.07	7.89	89	2	2.064	2	56	940	1.8	1.8	2.007	78	585	0.8	4	500
3.65	7.09	31.25	31.92	31.74	7.63	8.22	8.03	101	2	2.000	2	65	955	3	3	2.293	75	615	1	4	500
3.99	7.34	31.39	31.82	31.73	7.59	8.25	7.87	84	2	2.000	2	106	605	4.8	4.8	2.764	69	395	1.8	4	500
2.84	7.49	31.55	31.75	31.83	7.6	8.31	8	110	2	2.000	2	134	945	6.5	6.5	3.157	71	520	2.2	4	500
2.96	7.59	31.57	31.68	31.97	7.66	8.3	8.02	101	2	2.000	2	130	830	2.75	2.75	3.121	67	515	1.25	4	500
4.3	7.59	31.64	31.57	31.7	7.63	8.36	7.94	84	2.7	2.100	2	190	690	4	4	3.550	72	420	1	4	500
2.4	7.63	31.49	31.79	31.79	7.68	8.31	7.85	104	2	2.100	2	152	960	4.4	4.4	3.893	75	605	2.6	4	500
1.78	7.51	31.65	31.47	31.77	7.75	8.31	7.9	68	3.24	2.277	2	128	725	12	12	5.350	13	470	1.4	3	500
6.4	7.57	31.41	31.38	31.28	7.72	8.39	8.21	114	2	2.277	2	404	960	3.4	3.4	5.407	79	585	1.6	2	500
5.9	7.82	30.73	31.15	30.93	7.6	8.35	8.1	102	2	2.277	2	114	940	0.8	0.8	4.836	78	680	0.8	3	500
6.27	7.69	30.02	30.68	28.95	7.33	8.34	8.01	106	2	2.277	2	78	880	1.4	1.4	4.107	76	540	0.8	4	500
5.49	7.81	30	30.2	28.79	7.55	8.49	8	194	2	2.277	2	96	945	4.2	4.2	4.314	74	585	2.8	3	500
5.88	7.79	29.44	29.48	28.13	8.01	8.59	8.2	89	2	2.177	2	74	945	1.8	1.8	4.000	82	585	1.8	5	500
6.04	7.82	29.58	29.01	29.31	8	8.52	8.27	70	2	2.177	2	76	1030	2.6	2.6	3.743	76	650	1.6	5	500
5.89	7.71	29.92	29.97	28.46	7.71	8.54	8.23	63	3.16	2.166	2	84	885	2.2	2.2	2.843	74	585	1.4	7	500
5.45	7.04	29.17	28.4	27.87	7.18	8.52	8.2	77	2	2.166	2	66	1200	1	1	2.200	81	780	0.4	6	500
3.24	6.96	29.58	28.3	28.01	7.32	8.43	7.92	9	2	2.166	2	125	1330	2.2	2.2	2.200	84	840	1.2	6	500
4.71	8.04	29.23	28.27	28.12	7.66	8.6	8.15	88	2.19	2.193	2	175	1440	1.4	1.4	2.200	80	925	1.2	9	500
6.27	7.58	29.45	27.66	27.34	7.62	8.64	8.49	40	2	2.193	2	282	1335	1.4	1.4	1.800	78	905	1.4	16	500
5.78	5.35	29.48	27.91	27.8	7.61	8.18	8.26	87.8	2.14	2.213	2	268	1635	1.4	1.4	1.743	77	1110	1	20	500
2.71	1.05	29.56	28.23	28.11	7.61	7.98	8.1	141	2	2.213	2	276	2025	0.6	0.6	1.457	75	1395	0.6	23	500
4.08	1.55	29.22	28.43	28.33	7.55	7.93	8	217	2	2.047	2	344	2635	0.6	0.6	1.229	76	1845	1	23	500
2.62	1.75	26.01	26.72	26.65	6.43	7.89	7.96	224	2	2.047	2	228	2750	2	2	1.371	75	1930	1	34	500
6.57	3.5	27.77	29.3	29.2	6.84	7.22	7.44	365	2	2.047	2	204	3025	3.8	3.8	1.614	80	2125	2.4	31	500
3.54	6.73	27.46	28.27	28.71	6.96	8.17	8.11	643	2	2.047	2	540	2955	1.5	1.5	1.271	78	2050	1.2	36	500
3.84	6.82	27.77	28.26	28.69	6.44	8.07	8.09	291	2	2.020	2	204	3025	3.8	3.8	1.786	80	2125	2.4	31	500
6.57	3.5	27.77	29.3	29.2	6.84	7.22	7.44	365	2	2.020	2	204	3025	3.8	3.8	1.786	80	2125	2.4	31	500
7.55	1.33	27.71	26.8	29.1	6.85	7.98	7.98	260	2	2.000	2	272	3160	2.6	2.6	1.957	78	2225	1.2	55	500
1.85	6.18	26.4	26.2	8.1	6.85	7.54	8.2	406	2	2.000	2	344	3375	2.2	2.2	2.186	78	2720	1.8	36	500
6.83	6.32	25.81	26.1	8	7.46	7.49	7.83	380	2.23	2.033	2	365	3790	1.2	1.2	2.271	77	2595	1.2	32	500
1.62	7.46	25.86	26.4	6.8	6.87	7.81	7.8	214	2.51	2.106	2	372	3710	1.4	1.4	2.186	78	2685	0.4	20	500
7.07	0.45	25.84	26.1	7.4	7.06	7.7	8.47	388	2	2.106	2	472	3825	4	4	2.543	77	2105	3.2	18	500
7.1	0.43	25.89	26.1	6.5	6.89	8.36	8.45	358	2	2.106	2	336	2890	2.4	2.4	2.343	76	1155	1.6	17	500
6.74	0.52	25.81	27.7	8.2	6.78	8.02	8.34	1071	3.31	2.293	2	228	1580	3.6	3.6	2.486	77	1605	2.8	30	500
6.21	0.48	25.94	24.6	27.6	7.01	8.62	8.83	964	2.29	2.394	2	520	2180	5.6	5.6	3.057	70	1200	5.6	28	500
6.33	0.8	26.41	25.4	24.3	7.21	8.67	9	254	2.76	2.443	2	572	1615	3.2	3.2	3.200	74	1870	2	25	500
6.61	1.28	25.5	27	7.41	8.19	8.91	8.246	236	7.85	3.246	2	680	2600	28.8	28.8	3.577	71	1975	22	24	500
4.93	6.56	26.44	26.2	27	7.26	8.22	8.93	477	10.7	4.416	2	515	2770	10	10	8.371	74	1795	8.6	24	500
6.84	0.78	26	26.3	27.2	7.41	8.07	8.07	496	2	4.416	2	510	2535	9.4	9.4	9.143	70	1760	7	20	500
5.58	1.93	25.23	27.2	27.4	7.68	7.9	8.41	482	13.8	6.101	3.031	610	1975	32.5	32.5	13.443	77	1365	22	26	500
1.02	1.04	25.98	26.7	27	7.55	8.01	8.44	375	3.02	6.060	3.065	376	2305	1.3	1.3	13.114	75	1585	1.3	19	500

Aqua Aire Statistical Summaries

0.83	0.27	26.21	26.41	26.08	7.43	8	7.96	532	2	6.019	3.065	255	2450	1	12.314	4.650	81	1670	0.4	20	500
0.93	0.48	25.69	26.73	26.27	7.48	7.77	8.03	184	2	5.910	3.065	154	2410	0.8	11.971	4.537	78	1670	0.4	19	500
0.81	0.18	25.79	26.85	26.48	7.26	7.4	7.47	128	2	5.074	3.065	134	2330	1.8	8.114	4.537	69	1510	1.6	19	500
2.63	0.22	25.56	27.05	26.53	6.98	7.44	7.48	184	3.1	3.989	3.102	96	2205	3	7.114	4.550	78	1470	2.4	10	500
1.85	0.28	25.52	26.01	26.86	7.11	7.37	7.41	75	3.54	4.209	3.115	68	2250	5	6.486	4.543	77	1510	3.8	18	500
1.02	0.06	25.46	26.69	26.62	6.93	7.44	7.44	91	3.65	2.759	3.170	192	2180	2.2	2.157	4.683	75	1455	1.8	18	500
1.49	0.18	25.69	25.93	26.36	7	7.49	7.44	52	2	2.613	3.170	90	1715	7.8	3.086	4.870	76	1055	3	20	500
0.6	0.71	25.54	25.76	25.17	7.02	7.5	7.43	56	2	2.613	3.163	114	2175	3.4	3.429	4.937	78	6	1.4	21	500
0.14	0.63	25.75	25.52	23.24	7.05	7.53	7.3	99	2	2.613	3.159	128	1845	9.8	4.714	5.230	72	1235	9.8	19	500
0.88	0.23	25.43	25.12	25.41	7.48	7.54	7.19	69	2	2.613	3.159	128	1785	1.8	3.571	4.950	74	1505	7.2	21	500
0.24	0.42	22.1	24.69	22.73	7.48	7.72	7.31	105	2	2.456	3.159	93	2210	13.2	6.171	5.650	78	1290	2.4	18	500
1.15	1.23	25.75	24.45	22.48	7.03	7.54	7.19	193	2.38	2.950	3.171	214	2015	3.4	5.943	5.743	73	1540	0.4	16	500
0.44	2.61	25.45	24.36	22.42	6.9	7.59	7.42	224	2.78	2.166	3.197	288	2200	1.2	5.771	5.710	74	1440	1.1	18	500
0.14	3.99	25.53	24.29	22.36	6.86	7.62	7.2	226	2	2.166	3.197	316	2155	1.2	4.829	5.700	74	1545	1.4	17	500
0.48	3.41	25.59	24.28	22.78	7.08	7.66	7.19	75	2	2.166	3.197	274	2155	1.4	4.543	5.620	76	1510	3.4	8	500
0.5	3.77	25.42	24.42	22.54	7.36	7.66	7.19	194	2	2.166	3.197	544	1935	4.2	4.886	5.673	73	1555	33.5	5	500
0.76	4.31	24.36	25.07	24.11	7.55	7.66	7.47	352	2	2.166	3.197	244	1920	4.7	4.157	5.743	77	1390	3	2	500
2.53	4.5	23.88	24.94	24.79	7.24	7.65	7.44	328	2	2.166	3.197	320	1210	4.5	2.914	5.820	76	1395	4	3	500
1.65	4.18	23.84	25.28	23.25	7.43	7.68	7.63	343	2	2.111	3.190	460	900	5.2	3.171	5.953	78	875	4	1	500
3.37	4.06	24.62	24.2	25.11	7.28	7.61	7.52	409	2	2.000	3.173	268	174	5	3.743	6.073	74	1305	5.2	1	500
3.24	3.62	23.32	23.88	22.41	7.65	7.7	7.24	250	2.2	2.029	3.179	136	246	6.2	4.457	6.147	79	124	3.8	2	500
3.81	4.81	23.89	24.06	22.19	7.48	7.18	7.7	321	2	2.029	3.179	128	370	5.2	5.000	6.240	76	172	2.4	2	500
4.13	4.05	24.42	24.02	23.54	7.36	7.69	7.68	442	8.87	3.010	3.265	368	430	2.4	4.743	6.200	95	266	2.4	2	500
3.56	3.91	24.37	24.19	23.84	7.31	7.87	7.83	216	11.12	4.313	3.659	127	426	2.4	4.414	6.060	79	312	3.8	0	500
3	3.81	23.72	24.36	23.99	7.37	7.84	7.77	188	2	4.313	3.634	100	106	5.6	4.571	6.140	74	306	20	1	500
1.63	0.14	23.39	24.57	24.19	7.19	7.41	7.58	204	2	4.313	3.439	102	168	24	2.257	5.980	79	82	20	1	500
1.92	0.14	23.23	24.65	24.2	7.01	7.43	7.58	172	3.44	4.519	3.197	114	106	24.5	10.043	6.463	83	108	21	1	500
0.82	0.08	23.18	24.61	24.49	7.36	7.41	7.48	242	4.46	4.841	3.279	102	136	23.5	12.514	6.933	75	80	2.2	5	500
1.19	0.31	22.93	24.53	23.37	7.23	7.44	7.53	123	14	6.556	3.285	208	930	2.6	12.143	5.937	66	102	1	16	500
0.95	0.19	23.34	24.41	24.34	7.7	7.39	7.52	155	5.8	6.117	3.378	123	2530	1.4	12.000	5.940	73	685	2	15	500
0.71	0.12	22.7	24.27	24.11	7.23	7.4	7.49	146	2	4.814	3.378	168	2185	2	11.943	5.973	68	1685	1	15	500
1.28	0.09	21.94	24.34	24.09	7.33	7.37	7.41	108	2	4.814	3.378	114	2620	1.6	11.371	6.000	73	1510	0.2	14	500
1.62	0.11	22.08	24.07	24	8.08	7.41	7.53	158	2	4.814	3.378	328	2720	1.2	8.114	5.980	70	1770	1	13	500
1.38	0.17	22.16	24.01	23.83	8.1	7.46	7.59	120	2	4.609	3.341	51	2710	1.2	4.786	5.920	68	1830	1	14	500
1.28	0.08	22.43	23.99	23.83	7.98	7.45	7.56	222	2	4.257	3.290	106	2655	1.2	1.600	5.793	74	1815	2.5	14	500
1.1	1.68	22.18	23.39	23.09	7.68	7.61	7.49	108	2	2.643	3.235	124	2030	3.8	1.771	5.847	28	1805	3.4	9	500
1.22	0.1	21.93	23.8	22.5	7.58	7.49	7.56	215	2	2.000	3.235	48	2140	3.4	2.057	5.700	77	1340	1.4	9	500
1.37	0.2	21.61	23.69	21.67	7.62	7.48	7.63	277	2	2.000	3.235	77	2920	1.4	1.971	5.633	80	1385	2	14	500
1.37	0.16	22.72	23.78	19.36	7.43	7.44	7.56	50	2	2.000	3.235	48	2765	2.6	2.114	5.660	87	1910	0.9	13	500
0.66	1.57	22.93	23.49	22.29	7.43	7.53	7.44	79	2	2.000	3.235	222	2575	1.4	2.143	5.380	85	1765	1	12	500
0.82	4.76	22.4	23.28	23.49	7.56	7.48	7.43	94	2	2.000	3.235	120	2575	1.4	2.143	5.380	85	1765	1	12	500
1.1	1.68	22.18	23.39	23.09	7.68	7.61	7.49	108	2	2.000	3.235	57	2420	1	2.114	4.973	77	1665	1	12	500
1.32	0.31	21.22	23.46	23.22	7.69	7.51	7.6	85	2	2.000	3.222	96	1975	1.2	2.114	4.900	72	1535	0.6	12	500
0.46	0.46	21.37	22.89	23.26	7.62	7.56	7.56	105	2	2.000	3.196	160	2140	0.6	1.657	4.887	77	1225	0.8	12	500
0.76	0.41	21.36	22.37	22.77	7.6	7.5	7.59	16.5	2	2.000	3.196	152	2370	3.6	1.896	4.967	86	1340	0.8	11	500
0.75	0.23	22.12	22.07	22.26	7.49	7.49	7.62	22.5	2	2.000	3.196	124	1790	1.8	1.743	4.980	71	1495	2.2	14	500
1.69	0.18	21.75	22.13	21.98	7.27	7.61	7.7	32	2	2.000	3.196	70	2600	2.6	1.743	4.927	73	1175	2.6	10	500
1.06	1.11	20.81	22.18	22	7.37	7.54	7.54	68.5	2	2.000	3.196	140	2035	3	1.971	4.870	68	1650	1.6	11	500
0.58	1.43	20.95	22.2	22.09	7.65	7.71	7.64	69	2	2.000	3.196	92	2390	2.2	2.143	4.793	69	1295	0.6	12	500
0.74	1.14	20.2	21.86	22	7.5	7.68	7.65	108	2	2.000	3.196	60	2295	1	2.114	4.653	80	1570	1.4	12	500
0.59	1.03	19.2	21.95	21.49	7.36	7.91	7.79	76	2	2.000	3.196	52	3030	2.2	2.343	4.560	74	1465	1.2	14	500
0.74	1.28	18.5	21.6	21.44	7.4	7.91	7.85	80	2	2.000	3.190	60	2465	2.2	2.143	4.427	73	1900	2	14	500
0.7	1.3	20.03	20.76	20.52	7.84	7.8	7.79	149	2	2.000	3.190	72	2676	2.8	2.286	4.347	79	1590	1.4	12	500

Aqua Aire Statistical Summaries

0.64	1.47	20.17	20.23	19.57	7.79	8	7.59	69	2	2,000	2,961	44	2500	1.4	2,114	4,313	82	1716	18.4	11	500
0.63	1.26	20.72	20.17	19.14	7.76	8.14	7.86	60	6.54	2,849	2,808	50	2725	28.8	5,800	5,193	86	1830	3.4	4	500
0.14	0.88	20.62	20.33	20.44	7.61	7.87	7.3	72	4.1	2,949	2,878	96	1110	4.8	6,171	5,167	72	1790	2	6	500
0.59	0.22	20.35	20.45	20.08	8.79	7.81	7.25	72	2.21	2,979	2,885	164	720	2	6,814	4,433	82	749	1.2	4	500
0.42	1.11	19.56	20.66	20.05	7.44	8.31	8	60	2	2,979	2,837	130	425	1.6	6,229	3,670	76	479	1.4	1	500
1.8	1.12	19.82	21.56	19.29	7.94	8.24	8.16	34.5	4	3,264	2,822	106	2035	2.4	6,257	2,967	79	285	5.2	10	500
1.17	1.21	18.61	21.56	21	7.48	8.18	8.24	64	2	3,264	2,422	98	2385	7	6,857	3,113	77	1330	1.3	12	500
1.05	1.76	19.85	21.9	21.36	7.37	8.09	7.88	102	2	3,264	2,295	112	2320	3.2	7,114	3,173	72	1600	4.4	14	500
0.39	1.35	17.98	22.02	21.65	7.4	7.96	7.63	83	3.74	2,854	2,353	140	2360	6	3,857	3,307	75	1540	2.4	11	500
0.18	0.63	17.25	20.7	21.24	7.65	7.89	7.75	88	8.44	3,494	2,568	60	2495	6.4	4,086	3,467	77	1460	3.6	12	500
0.13	0.2	17.95	20.34	20.55	7.35	7.73	7.5	104	2	3,454	2,568	47	1625	5	4,514	3,593	73	1615	0.6	10	500
0.27	0.57	17.18	21.21	20.18	7.45	7.59	7.23	152	2	3,169	2,568	56	2060	0.6	4,371	3,573	73	1075	1.2	13	500
0.64	0.78	12.98	20.21	20.66	8.65	7.76	7.79	140	2	3,169	2,568	64	2490	1.4	3,400	3,493	73	1275	1.4	12	500
0.87	0.79	16.58	19.78	19.92	8.84	7.8	7.86	316	2	3,169	2,568	72	2800	2.6	3,314	3,467	87	1565	0.8	13	500
0.76	0.65	8.39	19.6	19.51	8.85	7.86	7.01	95	2	2,920	2,568	123	1955	1	2,800	3,453	79	1780	1.8	13	500
0.83	0.59	10.37	19.4	19.35	8.84	7.91	7.99	79	2	2,000	2,568	194	2624	1.8	1,943	3,427	70	1185	1.4	15	500
0.76	0.38	18.72	19.06	19.25	8.98	7.86	8.04	83	2	2,000	2,568	120	2708	1.8	1,486	3,440	73	1680	1.2	15	500
0.82	0.53	19.14	19.1	18.99	8.37	7.88	7.03	46	2	2,000	2,568	100	2690	1.4	1,600	3,453	77	1732	0.6	14	500
0.92	0.73	19.35	18.81	18.85	8.32	7.98	8.1	172	2	2,000	2,568	150	2280	1	1,571	3,447	75	1720	1	13	500
0.96	0.8	19.94	18.57	18.61	8.04	7.93	8.05	271	2	2,000	2,568	57	1325	1.2	1,543	3,467	78	1485	1.2	5	500
1.02	1.03	19.78	18.41	18.21	8.25	7.98	8.07	120	2	2,000	2,568	52	2560	1.4	1,371	3,393	82	1475	0.8	15	500
1.01	1.05	19.33	18.62	17.58	8.17	7.95	8.1	59	2	2,000	2,568	55	1250	0.8	1,343	3,360	73	1610	0.8	14	500
1.03	0.99	18.85	18.68	18.46	8.6	8.09	8.16	106	2	2,000	2,568	44	2820	1.2	1,257	3,313	76	1670	0.8	13	500
0.79	1.09	18.06	18.47	18.24	8.57	8.23	8.19	57	2	2,000	2,568	82	2840	0.8	1,114	3,240	75	1500	1.8	8	500
0.76	0.82	17.7	18.32	18.1	8.55	8.18	8.06	7.83	2	2,000	2,568	77	2310	1.8	1,171	3,227	70	1795	2.4	8	500
0.71	0.74	19	17.61	17.16	7.7	8.12	8.04	40	2	2,000	2,568	78	2485	3	1,457	3,293	81	1470	1.2	8	500
0.65	0.74	16.99	17.4	17.27	8.55	8	8.99	45	2	2,000	2,568	112	2092	1.4	1,486	3,267	68	1590	2.8	5	500
0.98	0.76	16.72	17.63	17.33	8.66	9	8.34	55	2	2,000	2,568	88	1652	4.8	1,971	3,353	80	1332	0.8	5	500
0.78	0.99	15.98	17.94	17.12	8.96	8.31	8.21	69	2	2,000	2,568	52	1730	0.8	1,971	3,353	80	1332	0.8	5	500
0.8	0.96	15.96	17.72	17.18	8.93	8.26	8.08	65	2	2,000	2,568	54	1770	2.5	2,157	3,323	51	1152	1.75	5	500
0.68	0.8	17.5	17.01	17.25	8.88	8	8.04	75	2.89	2,127	2,446	82	2540	0.8	2,157	2,390	1160	0.8	0.8	0.8	500
0.72	0.66	16	17.54	16.91	7.24	7.97	8.01	82	2.42	2,187	2,390	68	2040	1.4	2,100	2,277	1700	0.8	0.8	0.8	500
0.71	0.74	19	17.61	17.16	7.7	8.12	8.04	40	2	2,187	2,363	164	2425	0.8	1,786	2,237	1390	1.2	2.2	2.2	500
0.71	0.66	19.78	17.11	16.11	7.3	8	7.93	58	2	2,187	2,363	216	2290	1.2	1,757	2,223	1510	54	54	54	500
0.74	0.64	18.39	16.61	16.18	7.25	7.77	8.06	88	2	2,187	2,316	260	2220	3.2	1,529	2,250	1510	54	54	54	500
0.69	0.8	19.57	16.53	16.04	7.26	8.01	7.85	232	3.65	2,423	2,371	148	2485	9.9	2,829	2,347	1435				500
0.5	0.68	19.52	16.47	16	7.21	7.79	8.7	260	2.13	2,441	2,376	96	1716					1616			500
0.54	0.18	19.04	16.46	13.43	7.04	6.37	8.64	247	2	2,314	2,318	1560	2720					1072			500
0.63	0.14	19.52	16.47	16.89	6.64	6.46	8.75	176				616						1584			500
0.57	0.66	19.55	16.57	17.16	6.72	8.81	8.78	148				114									500
0.38	0.7	19.71	17.24	13.74	6.95	8.62	8.72	159													500
0.48	0.81	19.05	17.44	13.41	7.22	8.72	8.59	307													500
0.52	0.73	19.12	17.12	13.36	7.3	8.78	8.67	332													500
0.61	0.75	19.29	16.69	13.19	7.34	8.74	8.92	143													500
0.46	0.35	19.01	16.41	13.18	7.31	8.49	8.99	59													500
0.43	0.39	9.26	16.18	13.41	7.06	8.54	9.06	96													500
0.45	0.82	17.58	16.01	13.49	7.18	8.67	9.14														500
0.4	0.84	17.04	16.04	13.27	7.3	9.02	9.3														500
0.33	0.81	17.64	16	13.16	6.66	9.06	9.17														500
0.34	0.78	17.97	15.81	15.43	7.34	9.07	9.23														500
0.37	0.73	18.06	15.72	15.56	7.36	9.18	9.26														500

Aqua Aire Statistical Summaries

0.41	0.69	17.64	15.76	16.56	7.34	9.08	9.26	500
0.49	0.65	17.63	16.1	16.58	7.33	9.14	9.06	500
5.94	0.67	17.894	16.77	16.71	7.33	9.16	7.77	500
5.54	0.72	17.86	17.51	16.67	6.71	9.18	7.79	500
4.95	0.44	18.09	17.31	18.06	6.75	8.99	7.77	500
4.06	6.09	18.01	17.21	17.15	6.73	7.87	7.76	500
2.92	5.3	18.22	17.24	17.95	6.79	7.83	7.77	500
3.26	4.85	18.44	17.39	17.17	7.35	7.81	7.45	500
3.01	4.21	18.89	17.92	18.03	7.37	7.86	7.84	500
0.76	2.6	18.88	17.85	18.03	6.81	7.69	7.63	500
3.47	2.24	19.98	18.6	17.4	6.7	7.69	7.72	500
2.08	2.68	19.11	18.2	17.28	6.5	7.75	7.07	500
2.44	1.64	18.57	17.67	16.96	6.09	7.48	7.8	500
7.12	1.63	18.63	17.52	17.34	7.18	7.36	7.74	500
7.69	1.71	17.78	17.44	15.57	6.27	7.53	7.76	500
8.21	2.02	15.86	18.88	9.5	6.25	7.7	7.79	500
8.62	6.32	15.81	16.81	15.69	6.45	7.68	7.92	500
8.91	6.44	16.04	16.22	16.07	6.64	7.86	7.74	500
13.63	8.7	16.8	16.15	15.85	6.57	7.89	7.86	500
9.84	9.12	16.47	16.4	15.96	6.42	7.26	7.96	500
8.12	9.69	16.18	16.48	15.9	6.56	7.95	7.92	500
8.49	10.41	14.4	16.26	15.8	6.38	8.01	7.93	500
9.36	28.62	14.07	16.17	15.9	6.57	8.04	8.02	500
10.02	6.8	14.11	16.11	16.07	6.61	7.8	8.01	500
9.61	7.83	15.17	16.22	16.1	6.84	7.87	8.01	500
9.39	8.72	15.7	16.37	15.64	7.04	7.94	7.97	500
8.74	15.95	15.38	16.57	15.93	6.46	7.92	7.97	500
9.34	15.28	15.25	16.61	16.58	6.68	7.93	7.94	500
9.88	8.35		16.54	16.72		7.87	7.96	500
9.75	19.86		16.84	17.03		7.84	8.1	500
9.68	8.18		17.21	17.23		7.84	8.07	500
7.98	10.35		17.48	17.5		7.97	7.63	500
7.4	10.34		17.66	6.33		8.17	7.54	500
6.51	9.95		17.8	15.45		8.15	7.38	500
7.1	8.21		17.68	14.46		7.68	7.2	500
5.01	7.41		17.59	14.4		7.6	7.34	500
6.38	6.11		17.37	13.99		7.45	7.39	500
7.69	0.31		16.89	14.35		7.15	7.5	500
7.09	2.32		16.51	13.78		7.29	7.53	500
8.07	7.23		16.35	13.99		7.44	7.63	500
6.54	7.86		16.35	12.81		7.54	7.44	500
7.57	8.47		16.39	12.81		7.62	7.5	500
7.51	10.73		15.42	13.08		7.67	7.66	500
8.54	13.57		15.22	13.52		7.66	7.8	500
8.57	10.45		15.22	14.07		7.65	7.64	500
8.12	10.31		15.46	14.29		7.73	7.61	500
8.12	10.79		15.76	14.49		7.76	7.5	500
7.05	9.2		16.03			7.86	7.2	500
8.06	9.29		16.02			7.79	7.3	500
7.69	9.36					7.76		500
	9.18					7.7		500
	9.65					7.6		500



This Page Intentionally Left Blank

# APPENDIX B

## BAYLOR WORKSHEETS

This Page Intentionally Left Blank



Page 2 of Data Sheet Collection Sheet

Full Name of:

Person Recording Data:

Person obtaining samples:

Below, Initial EVERY Blank

T-Cross Cleaned

	<u>Cleaned by</u>	<u>Checked by</u>
Unit 1	_____	_____
Unit 2	_____	_____
Unit 3	_____	_____
Unit 4	_____	_____
Unit 5	_____	_____

All Caps, Bottles and graduated cylinders present:

\_\_\_\_\_

YSI 610-DM Meter present and working:

Probe put in Water

\_\_\_\_\_

Phone call made to 710-3405

\_\_\_\_\_

I have obtained the samples and conducted testing to Standard 17 & 18 procedures and have, to the best of my ability, insured safe and accurate recording of said results.

I, as a representative of the Brazos River Authority, state that I have received the samples in good condition and take responsibility for them from Baylor University.

\_\_\_\_\_  
Signature of Baylor University Representative

\_\_\_\_\_  
Signature of B.R.A. WMARSS Representative

## Baylor Wastewater Treatment Program Stress Sequence Evaluation

### Stress A-1

#### Wash Day:

Added three times in one five day week.

- \_\_\_\_\_ DAY 1 - 8:30 am - 11:30 am 3 wash loads = 105 gallons (3 wash and 6 rinse cycles)
- \_\_\_\_\_ DAY 2 - Collect extra grab sample
- \_\_\_\_\_ DAY 3 - 8:30 am - 11:30 am 3 wash loads = 105 gallons (3 wash and 6 rinse cycles)
- \_\_\_\_\_ DAY 4 - Collect extra grab sample
- \_\_\_\_\_ DAY 5 - 8:30 am - 11:30 am 3 wash loads = 105 gallons (3 wash and 6 rinse cycles)

\* This Stressing is followed by a SEVEN day rest period of Normal Loading

### Stress A-2

#### Working Parents:

No Loading 9:00 am to 5:00 pm for 5 consecutive days.

- \_\_\_\_\_ DAY 1 - Load 6-9:00 am 40% flow. Load 5-8:00 pm 60% flow including 1 wash load.
- \_\_\_\_\_ DAY 2 - Load 6-9:00 am 40% flow. Load 5-8:00 pm 60% flow including 1 wash load.
- \_\_\_\_\_ DAY 3 - Load 6-9:00 am 40% flow. Load 5-8:00 pm 60% flow including 1 wash load.
- \_\_\_\_\_ DAY 4 - Load 6-9:00 am 40% flow. Load 5-8:00 pm 60% flow including 1 wash load.
- \_\_\_\_\_ DAY 5 - Load 6-9:00 am 40% flow. Load 5-8:00 pm 60% flow including 1 wash load.

\* This Stressing is followed by a SEVEN day rest period of Normal Loading

### Stress A-3

#### Equipment Power Failure:

All power to residential wastewater treatment system off for 48 hours, one time only.

Feed off 8:00 pm on stress rest day seven.

- \_\_\_\_\_ DAY 1 - No Loading
- \_\_\_\_\_ DAY 2 - No Loading until 9:00 pm. 9-12(midnight) 60% flow inc. 1 wash load.

\* This stressing is followed by a SEVEN day rest period of Normal Loading.

### Stress A-4

#### One Week Vacation:

No loading over 9-day period but all power on and sudden shock when family returns home.

Normal Loading 6-9:00 am, 11-2:00 pm. Then feed off at 5:00 pm. on rest day seven.

- \_\_\_\_\_ DAY 1 - Feed Off
- \_\_\_\_\_ DAY 2 - Feed Off
- \_\_\_\_\_ DAY 3 - Feed Off
- \_\_\_\_\_ DAY 4 - Feed Off
- \_\_\_\_\_ DAY 5 - Feed Off
- \_\_\_\_\_ DAY 6 - Feed Off
- \_\_\_\_\_ DAY 7 - Feed Off
- \_\_\_\_\_ DAY 8 - Feed Off
- \_\_\_\_\_ DAY 9 - 5-8:00 pm 60% flow including 3 wash loads.

\* This stressing is followed by a three week period of Normal Loading.

This Page Intentionally Left Blank

# **APPENDIX C**

## **OFFICIAL DATA REPORT**

This Page Intentionally Left Blank

Aqua Aire Official Test Data

Date	DO effluent	DO aeration	Temp influent	Temp aeration	Temp effluent	pH influent	pH aeration	pH effluent	CBOD influent	CBOD effluent	TSS influent	TSS aeration	TSS effluent	VSS Int (%)	VSS aeration	VSS effluent	SS 45 m	Dosing GPD
8/1/2001																		
8/2/2001																		
8/3/2001																		
8/4/2001																		
8/5/2001																		
8/6/2001																		
8/7/2001																		
8/8/2001																		
8/9/2001																		
8/10/2001	2.35	0.26	31.4	32.2	32.25	7.52	7.74	7.83	ns	ns	ns	ns	ns	ns	ns	ns	500	
8/11/2001	2.45	0.65	31	31.8	32.36	7.5	7.81	7.87	ns	ns	ns	ns	ns	ns	ns	ns	500	
8/12/2001	2.69	3.02	31.35	32.41	32.4	7.74	7.86	7.87	861	1.32	ns	ns	ns	ns	ns	ns	500	
8/13/2001	3.68	5.22	31.25	32.42	32.03	7.12	8.03	7.94	148	1.98	158	645	2	78	470	1.8	500	
8/14/2001	3.03	0.32	31.22	32.38	32.43	7.23	7.68	7.8	149	1.9	122	1000	1.6	75	690	1.4	8	
8/15/2001	3.63	0.38	31.41	32.33	32.21	7.57	7.74	7.87	127	1.68	94	955	1.8	76	665	1.2	7	
8/16/2001	2.72	0.64	31.46	32.42	32.2	7.31	7.86	7.91	122	2.45	132	895	1	85	635	1	6	
8/17/2001	2.07	1.76	31.64	32.39	32.49	7.67	7.77	7.96	we	we	we	we	we	we	we	we	500	
8/18/2001	2.97	6.34	31.64	32.26	31.95	7.67	8.07	7.93	we	we	we	we	we	we	we	we	500	
8/19/2001	3.33	6.69	31.28	32.09	31.48	7.66	8.07	7.99	82	1.43	138	we	1.5	74	we	1.5	we	
8/20/2001	3.65	7.09	31.25	31.92	31.74	7.63	8.22	8.03	61	0.57	74	860	3.75	81	550	2.5	4	
8/21/2001	3.99	7.34	31.39	31.82	31.73	7.59	8.25	7.87	94	1.19	66	785	3	76	540	1.2	4	
8/22/2001	2.84	7.49	31.55	31.75	31.83	7.6	8.31	8	85	1.6	73	865	1	ne	535	0.6	4	
8/23/2001	2.96	7.59	31.57	31.68	31.97	7.66	8.3	8.02	93	1.6	70	885	2	84	640	1.75	3	
8/24/2001	4.3	7.59	31.64	31.57	31.7	7.63	8.36	7.94	101	1.95	we	830	we	we	545	we	3	
8/25/2001	2.4	7.63	31.58	31.49	31.79	7.68	8.31	7.85	84	1.09	we	we	we	we	we	we	500	
8/26/2001	1.78	7.51	31.65	31.47	31.77	7.75	8.31	7.9	110	1.36	58	we	1.8	79	we	0.8	we	
8/27/2001	6.4	7.57	31.41	31.38	31.28	7.72	8.39	8.21	101	1.95	65	940	3	78	585	1	4	
8/28/2001	5.9	7.82	30.73	31.15	30.93	7.6	8.35	8.1	84	1.09	106	955	4.8	75	615	1.8	4	
8/29/2001	6.27	7.69	30.02	30.68	28.95	7.33	8.34	8.01	104	2.7	134	605	6.5	69	395	2.2	4	
8/30/2001	5.49	7.81	30	30.2	28.079	7.55	8.49	8	68	0.68	130	945	2.75	71	520	1.25	4	
8/31/2001	5.88	7.79	29.44	29.48	28.13	8.01	8.59	8.2	we	we	we	830	we	we	515	we	4	
9/1/2001	ns	ns	ns	ns	ns	ns	ns	ns	we	we	we	we	we	we	we	we	500	
9/2/2001	ns	ns	ns	ns	ns	ns	ns	ns	114	3.24	190	ns	4	67	ns	1	500	
9/3/2001	6.04	7.82	29.58	29.01	29.31	8	8.52	8.27	102	ns	152	690	ns	72	420	ne	4	
9/4/2001	5.89	7.71	29.92	28.97	28.46	7.71	8.54	8.23	106	1.19	128	960	4.4	75	605	2.6	4	
9/5/2001	no readi taken								194	0.58	404	725	12	13	470	1.4	3	
9/6/2001	5.45	7.04	29.17	28.4	27.87	7.18	8.52	8.2	89	1.25	114	960	3.4	ne	585	1.6	2	
9/7/2001	3.24	6.96	29.58	28.3	28.01	7.32	8.43	7.92	we	we	we	940	we	we	680	we	3	
9/8/2001	4.71	8.04	sf	28.27	28.12	sf	8.6	8.15	we	we	we	we	we	we	we	we	500	
9/9/2001	sf	sf	sf	sf	sf	sf	sf	sf	70	0.77	78	we	0.8	we	we	0.8	we	
9/10/2001	sf	sf	sf	sf	sf	sf	sf	sf	63	0.43	96	880	1.4	79	540	0.8	4	

Aqua Aire Official Test Data

	DO effluent	DO aeration	Temp influent	Temp aeration	Temp effluent	pH influent	pH aeration	pH effluent	CBOD influent	CBOD effluent	TSS influent	TSS aeration	TSS effluent	VSS inf (%)	VSS aeration	VSS effluent	SS 45 m.	Dosing GPD
9/11/2001	6.27	7.58	29.28	27.66	27.34	7.62	8.54	8.49	77	1.36	74	945	4.2	78	585	2.8	3	500
9/12/2001	5.78	5.95	29.45	27.91	27.8	7.62	8.18	8.26	9	3.16	76	945	1.8	76	585	1.8	5	500
9/13/2001	2.71	1.05	29.48	28.23	28.11	7.61	7.98	8.1	88	1.44	84	1030	2.6	74	650	1.6	5	500
9/14/2001	4.08	1.55	29.56	28.43	28.33	7.61	7.93	8	we	we	we	we	we	we	565	we	7	500
9/15/2001	2.62	1.75	29.22	28.72	28.65	7.55	7.89	7.96	we	we	we	we	we	we	we	we	we	500
9/16/2001	3.54	6.73	ns	28.27	28.71	ns	8.17	8.11	40	1.08	66	we	2.2	82	we	1.4	we	500
9/17/2001	3.84	6.82	ns	28.26	28.69	ns	8.07	8.09	87.8	2.19	125	1200	1	76	780	0.4	6	500
9/18/2001	sf	sf	sf	sf	sf	sf	sf	sf	141	0.56	175	1330	2.2	74	840	1.2	6	500
9/19/2001	6.57	3.5	nr	nr	nr	nr	7.22	7.44	217	2.14	232	1440	1.4	74	925	1.2	we	500
9/20/2001	7.55	1.33	nr	nr	nr	nr	7.38	7.98	224	1.36	268	1335	1.4	81	905	1.4	9	500
9/21/2001	1.85	6.18	nr	nr	nr	nr	7.54	8.2	643	we	276	1635	we	80	1110	we	we	500
9/22/2001	6.83	6.32	nr	nr	29.2	nr	7.49	7.83	we	we	we	we	we	we	we	we	we	500
9/23/2001	1.62	7.46	nr	29.3	29.1	nr	7.81	7.8	291	0.55	ns	ns	1.4	we	we	1	we	500
9/24/2001	7.07	0.45	nr	26.8	8.1	nr	7.7	8.47	365	1.87	344	2025	0.6	78	1395	0.6	16	500
9/25/2001	7.1	0.43	nr	26.2	8	nr	8.36	8.45	260	1.06	228	2635	0.6	77	1845	1	20	500
9/26/2001	6.74	0.52	nr	26.1	6.8	nr	8.02	8.34	ns	0.78	ns	2750	2	ns	1930	1	23	500
9/27/2001	6.21	0.48	nr	26.4	7.4	nr	8.82	8.83	406	1.38	540	2955	1.5	75	2050	1.2	23	500
9/28/2001	6.33	0.8	nr	26.1	6.5	nr	8.67	9	we	we	204	3025	we	75	2125	we	we	500
9/29/2001	6.61	1.28	nr	26.1	8.2	nr	8.19	8.91	we	we	we	we	we	we	we	we	we	500
9/30/2001	4.93	6.56	nr	27.7	27.6	nr	8.22	8.93	380	1.1	268	we	3.8	76	we	2.4	we	500
10/1/2001	6.84	0.78	nr	24.6	24.3	nr	8.07	8.01	214	1.52	272	3085	2.6	78	2150	1.6	34	500
10/2/2001	5.58	1.93	nr	25.4	27	nr	7.9	8.41	388	2.23	344	3160	2.6	80	2225	1.2	36	500
10/3/2001	1.02	1.04	nr	25.7	27	nr	8.01	8.44	358	2.51	325	3375	2.2	78	ne	1.8	31	500
10/4/2001	0.83	0.27	nr	26.2	27.2	nr	8	7.96	1071	1.75	372	3790	1.2	ne	2720	1.2	39	500
10/5/2001	0.83	0.48	nr	26.3	27.4	nr	7.77	8.03	we	we	we	3710	we	we	2595	we	55	500
10/6/2001	0.81	0.18	nr	27.2	27.2	nr	7.4	7.47	we	we	we	we	we	we	we	we	we	500
10/7/2001	2.63	0.22	nr	26.7	26.08	nr	7.44	7.48	364	0.76	472	we	1.4	78	we	0.4	we	500
10/8/2001	1.85	0.26	26.01	26.41	26.2	6.43	7.37	7.41	254	3.31	336	3825	4	78	2685	3.2	36	500
10/9/2001	1.02	0.08	27.46	26.73	26.48	6.96	7.44	7.44	236	2.29	228	2890	2.4	77	2105	1.6	32	500
10/10/2001	1.49	0.18	27.77	26.85	26.53	6.44	7.49	7.44	477	2.76	520	1580	3.6	ne	1155	2.8	20	500
10/11/2001	0.6	0.71	27.77	27.05	26.86	6.84	7.5	7.43	496	7.85	572	2180	6.6	78	1605	5.6	18	500
10/12/2001	0.14	0.83	27.71	26.01	26.72	6.85	7.53	7.3	we	we	680	1615	we	77	1200	we	17	500
10/13/2001	0.88	0.23	26.4	26.69	26.36	6.85	7.54	7.19	482	10.7	we	we	we	we	we	we	we	500
10/14/2001	0.24	0.42	25.81	25.93	25.17	7.46	7.72	7.31	375	0.37	515	we	3.2	76	we	2	we	500
10/15/2001	1.15	1.23	25.86	25.76	23.24	6.87	7.54	7.19	532	13.8	510	2600	8.8	77	1870	2.2	30	500
10/16/2001	0.44	2.61	25.84	25.52	25.41	7.06	7.59	7.42	184	ne	610	2770	10	ne	1975	8.6	28	500
10/17/2001	0.14	3.39	25.89	25.12	22.73	6.89	7.62	7.2	128	ne	375	2535	ns	70	1795	ns	25	500
10/18/2001	0.48	3.41	25.81	24.69	22.48	6.78	7.66	7.19	184	we	we	we	we	we	1760	ns	24	500
10/19/2001	0.5	3.77	25.94	24.45	22.42	7.01	7.66	7.19	we	we	we	we	we	we	we	we	24	500
10/20/2001	0.76	4.31	26.41	24.36	22.36	7.21	7.66	7.47	we	we	we	we	we	we	we	we	we	500
10/21/2001	2.53	4.5	25.5	24.29	22.78	7.41	7.65	7.44	75	3.02	255	we	9.4	74	we	7	we	500

Aqua Aire Official Test Data

	DO effluent	DO aeration	Temp influent	Temp aeration	Temp effluent	pH influent	pH aeration	pH effluent	CBOD influent	CBOD effluent	TSS influent	TSS aeration	TSS effluent	VSS inf (%)	VSS aeration	VSS effluent	SS 45 m.	Dosing GPD
10/22/2001	1.65	4.18	26.44	24.28	22.54	7.25	7.68	7.63	91	ne	154		3.5	71		2.2	500	
10/23/2001	3.37	4.06	26	24.42	24.11	7.41	7.61	7.52	52		134	1975	1.3	74	1365	1.3	500	
10/24/2001	3.24	3.62	25.23	25.07	24.79	7.68	7.7	7.24	56		96	2305	1		1585	0.4	500	
10/25/2001	3.81	4.81	25.98	24.94	23.25	7.55	7.18	7.7	59	1.02	68	2450	0.8	70	1670	0.4	500	
10/26/2001	4.13	4.05	26.21	25.28	25.11	7.43	7.69	7.68	we	we	we	2410	we	we	1610	we	500	
10/27/2001	ns	ns	ns	ns	ns	ns	ns	ns	we	we	we	we	we	we	we	we	500	
10/28/2001	3.56	3.91	25.69	24.2	22.41	7.48	7.87	7.83	69	3.1	192	we	1.8	77	we	1.6	500	
10/29/2001	3	3.81	25.79	23.88	22.19	7.26	7.84	7.77	105	3.54	90	2330	3	75	1570	2.4	500	
10/30/2001	1.63	0.14	25.56	24.06	23.54	6.98	7.41	7.58	193	3.65	114	2205	5	81	1470	3.6	500	
10/31/2001	1.92	0.14	25.52	24.02	23.84	7.11	7.43	7.58	224	1.52	128	2250	2.2	78	1510	1.8	500	
11/1/2001	0.82	0.08	25.46	24.19	23.99	6.93	7.41	7.48	226	1.9	128	2180	la	69	1455	la	500	
11/2/2001	1.19	0.31	25.69	24.36	24.19	7	7.44	7.53				1715			1055		10	500
11/3/2001	0.95	0.19	25.54	24.57	24.2	7.02	7.39	7.52										500
11/4/2001	0.71	0.12	25.75	24.65	24.49	7.05	7.4	7.49	75	1.88	93		7.8	78	6		500	
11/5/2001	1.28	0.09	25.43	24.61	23.37	7.48	7.37	7.41	194	1.05	214	2175	3.4	77	1505	3	500	
11/6/2001	1.62	0.11	22.1	24.53	24.34	7.48	7.41	7.53	352	1.8	288	1765	1.8	75	1235	1.4	500	
11/7/2001	1.38	0.17	25.75	24.41	24.11	7.03	7.46	7.59	328	2.38	316	1845	9.8	76	1290	7.2	500	
11/8/2001	1.28	0.08	25.45	24.27	24.09	6.9	7.45	7.56	343	2.78	274	2210	13.2	78	1540	9.8	500	
11/9/2001	1.22	0.1	25.53	24.34	24	6.86	7.49	7.56	409	1.07		2015			1440		500	
11/10/2001	1.37	0.2	25.59	24.07	23.83	7.08	7.48	7.63	250	1.12							500	
11/11/2001	1.37	0.16	25.42	24.01	23.83	7.36	7.44	7.56	321	0.74	544						500	
11/12/2001	0.66	1.57	24.36	23.99	22.5	7.55	7.53	7.44	442	0.7	244	2200	1	72	1545	0.4	500	
11/13/2001	0.82	4.76	23.88	23.8	21.67	7.24	7.49	7.43			320	2155	1.2	78	1510	1	500	
11/14/2001	1.1	1.68	23.84	23.69	19.36	7.43	7.61	7.49			460	2155	ns	73	1555	ns	500	
11/15/2001	1.32	0.31	24.62	23.78	22.29	7.28	7.51	7.6	216	1.71	268	1935	1.4	74	1390	1.4	500	
11/16/2001	0.46	0.46	23.32	23.49	23.49	7.65	7.56	7.56				1920			1395		17	500
11/17/2001	0.76	0.41	23.89	23.28	23.09	7.48	7.5	7.59										500
11/18/2001	0.75	0.23	24.42	23.39	23.22	7.36	7.49	7.62	188	1.01	196							500
11/19/2001	1.69	0.18	24.37	23.45	23.28	7.31	7.61	7.7	204	1.35	128	1210	4.7	76	875	3.5	8	500
11/20/2001	1.06	1.11	23.72	22.89	22.77	7.37	7.54	7.54	172	2.2	368	900	4.5	73	1305	3	5	500
11/21/2001	0.58	1.43	23.39	22.37	22.26	7.19	7.71	7.64			ne				ne		2	500
11/22/2001	0.74	1.14	23.23	22.07	21.98	7.01	7.68	7.65										500
11/23/2001	0.59	1.03	23.18	22.13	22	7.36	7.91	7.79										500
11/24/2001	0.74	1.28	ne	22.18	22.09	ne	7.91	7.85										500
11/25/2001	0.7	1.3	ne	22.2	22	ne	7.8	7.79	242	1.45	127		5.2	77		4	500	
11/26/2001	0.64	1.47	22.93	21.86	21.49	7.23	8	7.59	123	ne	100	174	5	76	124	4	1	500
11/27/2001	0.63	1.26	23.34	21.95	21.44	7.7	8.14	7.86	156	8.87	102	246	6.2	78	172	5.2	1	500
11/28/2001	0.14	0.88	22.7	21.6	20.52	7.23	7.87	7.3	146	11.12	114	370	5.2	74	266	3.8	2	500
11/29/2001	0.09	0.22	21.94	20.76	19.57	7.33	7.81	7.25	108	4.52	102	430	2.4		312	2.4	2	500
11/30/2001	0.42	1.11	22.08	20.23	19.14	8.09	8.31	8				426			306		2	500
12/1/2001	1.6	1.12	22.16	20.17	20.44	8.1	8.24	8.16										500

Aqua Aire Official Test Data

Date	DO effluent	DO aeration	Temp influent	Temp aeration	Temp effluent	pH influent	pH aeration	pH effluent	CBOD influent	CBOD effluent	TSS influent	TSS aeration	TSS effluent	VSS inf (%)	VSS aeration	VSS effluent	SS 45 m.	Dosing GPD
12/2/2001	1.17	1.21	22.43	20.33	20.08	7.98	8.18	8.24	158	0.44	208		2.4	79		2.4		500
12/9/2001	1.05	1.76	21.93	20.45	20.05	7.58	8.09	7.88	120	3.44	123	106	5.6	76	82	3.8	0	500
12/4/2001	0.39	1.35	21.61	20.66	19.29	7.62	7.96	7.63	222	4.46	168	168	2.4		108	2	1	500
12/5/2001	0.48	0.91	22.72	21.16	21	7.43	7.91	7.86	215	14	114	106	4.5	95	80	2	1	500
12/6/2001	0.18	0.63	22.93	21.56	21.36	7.43	7.89	7.75	277	5.8	328	136	3.5	79	102	2.1	1	500
12/7/2001	0.13	0.2	22.4	21.9	21.85	7.56	7.73	7.5			930				665		5	500
12/8/2001	0.27	0.57	22.18	22.02	20.72	7.68	7.59	7.23										500
12/9/2001	0.64	0.78	21.22	21.28	21.24	7.69	7.76	7.79	50	1.01	51		2.6	74		2.2		500
12/10/2001	0.87	0.79	21.37	20.7	20.55	7.62	7.8	7.86	79	1.05	106	2530	1.4	79	1685	1	16	500
12/11/2001	0.76	0.65	21.36	20.34	20.18	7.6	7.88	7.01	94	1.08	124	2185	2		1510	2	15	500
12/12/2001	0.83	0.59	22.12	21.21	20.66	7.48	7.91	7.99	108	1.56	48	2620	1.6	83	1770	1	15	500
12/13/2001	0.76	0.38	21.75	20.21	19.92	7.27	7.86	8.04	85	0.64	77	2720	1.2	75	1830	0.2	14	500
12/14/2001	0.82	0.53	20.81	19.78	19.51	7.37	7.83	7.03	ne	1.04	ne	2710	1.2		1815	1	13	500
12/15/2001	0.92	0.73	20.95	19.6	19.35	7.65	7.98	8.1	ne	0	ne	2655	1.2	ne	1805	1	14	500
12/16/2001	0.96	0.8	20.2	19.4	19.25	7.5	7.93	8.05	105	0.52	222	2030	3.8	66	1340	2.5	14	500
12/17/2001	1.02	1.03	19.2	19.06	18.99	7.36	7.98	8.07	16.5	0.27	120	2140	3.4	73	1385	3.4	9	500
12/18/2001	1.01	1.05	18.5	19.1	18.85	7.4	7.95	8.1	22.5	0.77	ne	2920	1.4	ne	1910	1.4	9	500
12/19/2001	1.03	0.99	ne	18.81	18.61	ne	8.09	8.16	32	0.61	57	2765	2.6	68	1785	2	14	500
12/20/2001	ne	1.09	20.03	18.57	ne	7.84	8.23	ne	66.5	0.79	96	2575	1.4	73	1665	0.9	13	500
12/21/2001	0.79	0.82	20.17	18.41	18.21	7.79	8.18	8.19	69	0.78	160	2420	1	70	1535	1	12	500
12/22/2001	0.76	0.83	20.72	18.62	17.58	7.76	8.02	8.06	108	0.63	152	1975	1.2	68	1225	1	12	500
12/23/2001	0.7	0.74	20.82	18.68	18.46	7.61	8	8.04	76	0.66	124	2140	0.6	74	1340	0.6	12	500
12/24/2001	0.65	0.76	20.35	18.47	18.24	6.78	8	8.99	80	ne	70	2370	3.6	28	1495	1.8	12	500
12/25/2001	0.98	0.99	19.56	18.32	18.1	7.44	8.31	8.34	149	0.96	140	1790	1.8	77	1175	0.8	11	500
12/26/2001	0.78	0.96	19.82	17.6	17.36	7.94	8.26	8.21	69	1.59	92	2600	2.6	80	1650	2.2	14	500
12/27/2001	0.8	0.8	18.61	17.4	17.27	7.48	8	8.06	60	1.7	60	2005	3	87	1295	2.6	10	500
12/28/2001	0.68	0.66	19.85	17.63	17.33	7.87	7.97	8.04	ne	1.23	ne	2390	2.2	ne	1570	1.6	11	500
12/29/2001	0.72	0.74	17.98	17.94	17.12	7.4	8.12	8.01	72	1.24	52	2295	1	85	1465	0.6	12	500
12/30/2001	0.71	0.66	17.25	17.72	17.18	8	8	8.04	72	ne	60	3030	2.2	77	1900	1.4	12	500
1/1/2002	0.74	0.8	17.95	17.54	16.91	7.35	7.77	7.93	60	1.4	72	2465	2.2	72	1590	1.2	14	500
1/2/2002	0.69	0.68	17.18	17.81	17.18	7.45	7.79	7.85	64	1.69	50	2676	2.8	77	1716	2	14	500
1/3/2002	ne	0.18	12.98	17.11	ne	8.65	8.37	ne	ns	ns	50	2500	1.4	86	1830	1.4	12	500
1/4/2002	ne	0.14	16.58	16.61	ne	8.84	8.46	ne	102	6.54	96						11	
1/5/2002	0.5	0.66	8.39	16.53	16.11	8.11	8.85	8.81	ne	4.1	164	1110	4.8	73	740	3.4	4	
1/6/2002	0.54	0.7	10.37	16.47	16.18	8.84	8.62	8.64	83	2.21	130	ne	2	68	ne	2	6	500
1/7/2002	0.63	0.81	18.72	16.46	16.04	8.38	8.72	8.75	88	1.87	106	720	1.6	ne	470	1.2	4	500
1/8/2002	0.57	0.73	19.14	18.47	18.1	8.37	8.78	8.78	86	4	98	425	2.4	69	285	1.4	1	500
1/9/2002	0.38	0.75	19.35	16.57	13.43	8.32	8.74	8.72	104	2.17	112	2035	7	80	1330	5.2	10	500
1/10/2002	0.48	0.35	19.94	17.24	18.89	8.04	8.49	8.59	152	2.29	140	2385	3.2	74	1600	1.8	12	500
1/11/2002	0.52	0.39	19.78	17.44	17.16	8.25	8.54	8.67				2320			1540		14	500

Aqua Aire Official Test Data

	DO effluent	DO aeration	Temp influent	Temp aeration	Temp effluent	pH influent	pH aeration	pH effluent	CBOD influent	CBOD effluent	TSS influent	TSS aeration	TSS effluent	VSS inf (%)	VSS aeration	VSS effluent	SS 45 m.	Dosing GPD
1/12/2002	0.61	0.82	19.3	17.12	13.74	8.17	8.87	8.92										500
1/13/2002	0.46	0.84	18.65	16.69	13.41	8.57	9.02	8.99	ns	ns								500
1/14/2002	0.43	0.81	18.06	16.41	13.36	8.57	9.06	9.06	ns	ns								500
1/15/2002	0.45	0.78	17.7	16.18	13.19	8.55	9.07	9.14										500
1/16/2002	0.4	0.73	17.23	16.01	13.18	8.64	9.18	9.3										500
1/17/2002	0.33	0.69	16.99	16.04	13.41	8.55	9.08	9.17										500
1/18/2002	0.34	0.65	16.72	16	13.49	8.66	9.14	9.23										500
1/19/2002	0.37	0.67	15.98	15.81	13.27	8.96	9.16	9.26										500
1/20/2002	0.41	0.72	15.96	15.72	13.16	8.93	9.18	9.28	140	3.74	60		6	73	4.4		500	
1/21/2002	0.49	0.44	17.5	15.76	15.43	8.88	8.99	9.06	316	8.44	47	2360	6.4	79	1460	2.4	11	500
1/22/2002	5.94	6.09	16	16.1	15.56	7.24	7.87	7.77	95	2.66	67	2495	5	82	1615	3.6	12	500
1/23/2002	5.54	5.3	19	16.77	16.56	7.7	7.83	7.79	79	1.58	56	1625	0.6	86	1075	0.6	10	500
1/24/2002	4.95	4.85	19.78	17.51	16.58	7.3	7.81	7.77	83	0.45	64	2190	1.2	72	1405	1.2	13	500
1/25/2002	4.06	4.21	18.39	17.31	16.71	7.25	7.86	7.76				2060			1275		13	500
1/26/2002	2.92	2.6	19.57	17.21	16.67	7.26	7.69	7.77										500
1/27/2002	3.26	2.24	19.52	17.24	18.06	7.27	7.69	7.45	46	0.74	72		1.4	82		1.2	500	
1/28/2002	3.01	2.68	19.04	17.39	17.15	7.04	7.75	7.84	172	1.75	123	2490	2.6	76	1565	1.4	12	500
1/29/2002	0.76	1.64	19.52	17.92	17.35	6.64	7.48	7.63	271	1.42	194	2800	1	79	1780	0.8	13	500
1/30/2002	3.47	1.63	19.55	17.85	17.17	6.72	7.36	7.72	120	1.09	120	1955	1.8	77	1185	1.8	13	500
1/31/2002	2.08	1.71	19.71	18.6	18.03	6.95	7.53	7.07	59	1.24	100	2624	1.8	72	1680	1.4	15	500
2/1/2002	2.44	2.02	19.05	18.2	18.03	7.22	7.7	7.8				2708			1732		15	500
2/2/2002	7.12	6.32	19.12	17.67	17.4	7.3	7.68	7.74										500
2/3/2002	7.69	6.44	19.29	17.52	17.28	7.34	7.86	7.76	106	1.62	150		1.4	75		1.2	500	
2/4/2002	8.21	8.7	19.01	17.44	16.96	7.31	7.89	7.79	57	1.14	57	2690	1	77	1720	0.6	14	500
2/5/2002	8.62	9.12	9.26	18.88	17.34	17.06	7.26	7.92	7.83	1.14	52	2280	1.2	73	1485	1	500	
2/6/2002	8.91	9.69	17.58	16.81	15.57	7.18	7.95	7.74	50	1.67	55	1325	1.4	73	1475	1.2	500	
2/7/2002	13.63	10.41	17.26	16.22	9.5	7.3	8.01	7.86			44	2560	0.8	100	1610	0.8	500	
2/8/2002	9.84	28.62	17.64	16.15	15.69	6.66	8.04	7.96	45	0.08		1250			1670		500	
2/9/2002	8.12	6.8	17.97	16.4	16.07	7.34	7.8	7.92										500
2/10/2002	8.49	7.83	18.05	16.48	15.85	7.36	7.87	7.93	55	0.81	82		1.2	79		0.8	500	
2/11/2002	9.36	8.72	17.64	16.26	15.96	7.34	7.94	8.02	69	0.78	77	2320	0.8	87	1500	0.8	13	500
2/12/2002	10.02	15.95	16.17	15.9	15.9	7.33	7.92	8.01	65	0.92	78	2840	1.8	79	1795	1.8	5	500
2/13/2002	9.61	15.28	17.894	16.11	15.8	7.33	7.93	8.01	75	1.06	112	2310	3	70	1470	2.4	15	500
2/14/2002	9.39	8.35	17.85	16.22	15.9	6.71	7.87	7.97	82	1.26	88	2485	1.4	73	1590	1.2	14	500
2/15/2002	8.74	19.86	18.09	16.37	16.07	6.75	7.84	7.97				2092			1332		13	500
2/16/2002	9.34	8.18	18.01	16.57	16.1	6.73	7.84	7.94										500
2/17/2002	9.88	10.35	18.22	16.61	15.64	6.79	7.97	7.96	40	1.12	52		4.8	77		2.8	500	
2/18/2002	9.75	10.34	18.44	16.54	15.93	7.35	8.17	8.1	<2	1.05	54	1852	0.8	75	1152	0.8	8	500
2/19/2002	9.68	9.95	18.89	16.84	16.58	7.37	8.15	8.07	58	0.23	82	ns	2.5	78	ns	1.75	8	500
2/20/2002	7.98	8.21	18.88	17.21	16.72	6.81	7.68	7.63	88	2.89	68	1730	0.8	82	1065	0.8	500	
2/21/2002	7.4	7.41	19.38	17.48	17.03	6.7	7.6	7.54	232	2.42	164	1770	1.4	73	1160	0.8	500	



Aqua Aire Official Test Data

	DO effluent	DO aeration	Temp influent	Temp aeration	Temp effluent	pH influent	pH aeration	pH effluent	CBOD influent	CBOD effluent	TSS influent	TSS aeration	TSS effluent	VSS inf (%)	VSS aeration	VSS effluent	SS 45 m.	Dosing GPD
la - lab accident		ns - no sample		we - weekend														
pf - pump failure		unk - unknown																
sf - sonde failure		ne - no entry by lab																
bt - bad test																		
mc - missed cutoff time																		

This Page Intentionally Left Blank

# **APPENDIX D**

## **AA500T RESIDENTIAL WASTEWATER TREATMENT SYSTEM SPECIFICATIONS AND DRAWINGS**

This Page Intentionally Left Blank

AquaAire Sewage Treatment System  
 Model AA500T  
 Two Piece Tank

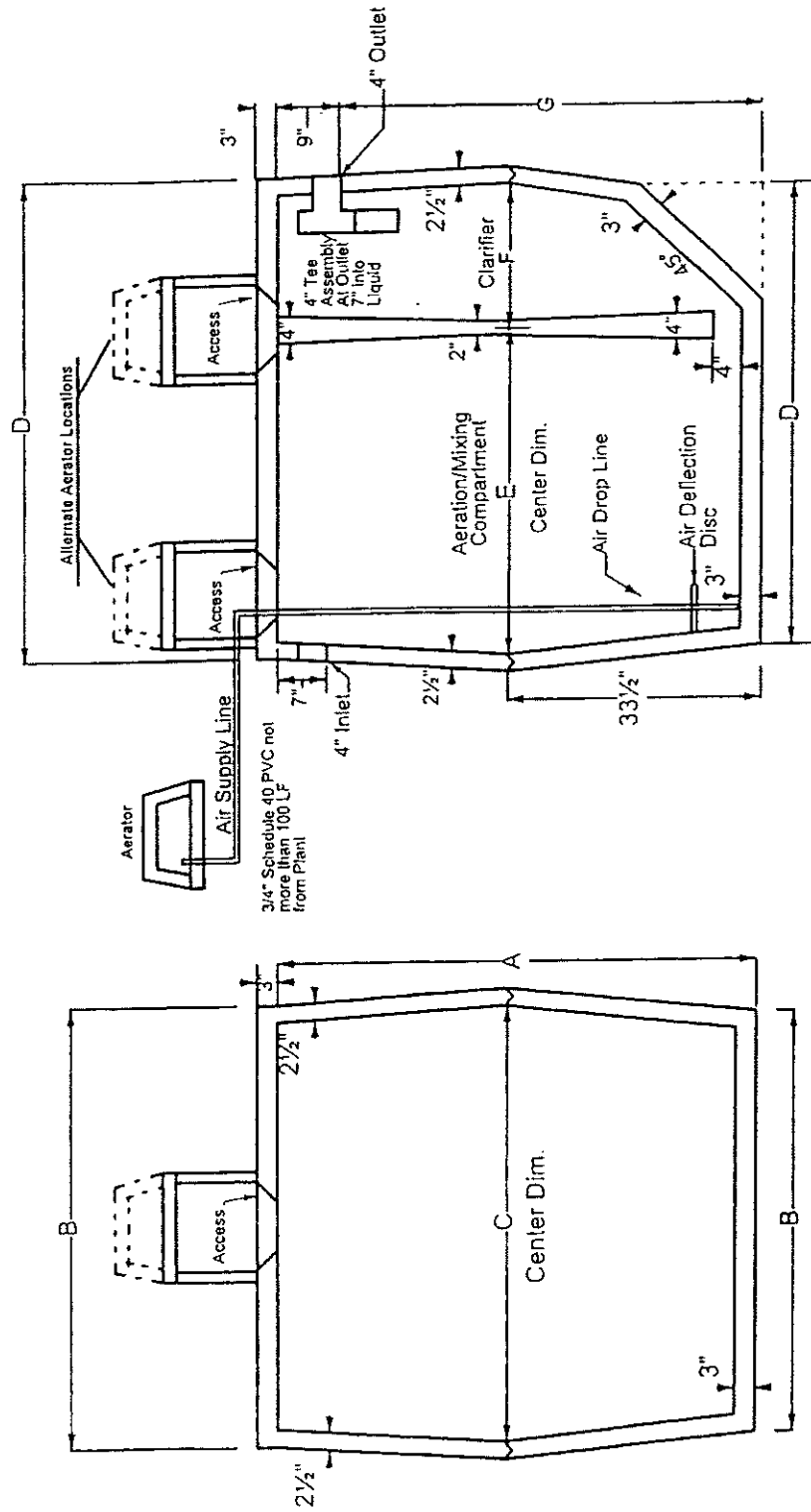

Schedule

Designation	Trtmt. Capacity	BOD Loading	Total Volume	Aeration Volume	Clarifier Volume	A	B	C	D	E	F	G
AA500T	500GPD	1.25	714	533	181	64	60	57	67½	44	18½	55

FIGURE 2

### Aqua Aire Diffusion System For AA500, 600, 750, 1000 and 1500

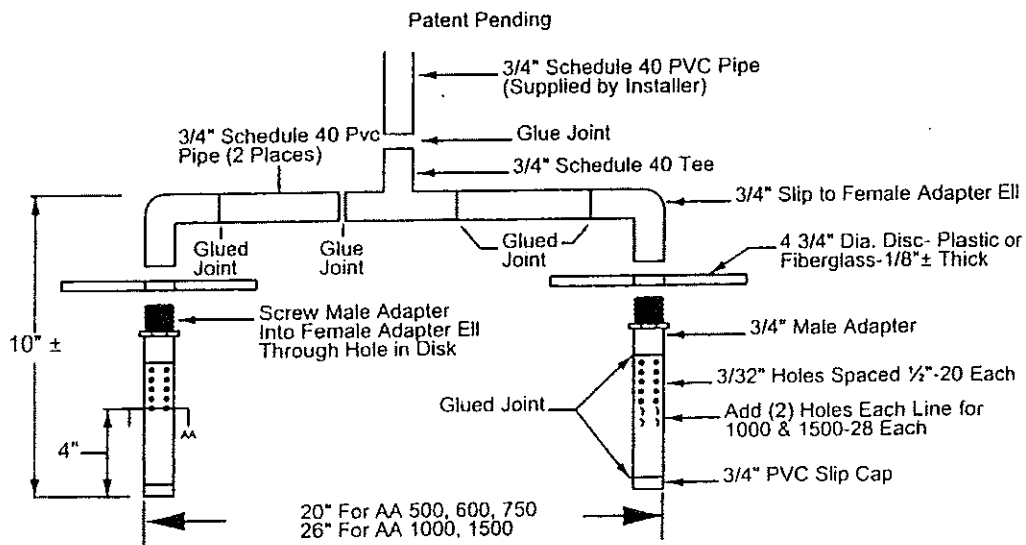

View AA

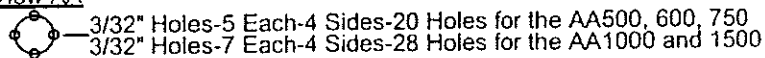

In-Tank View

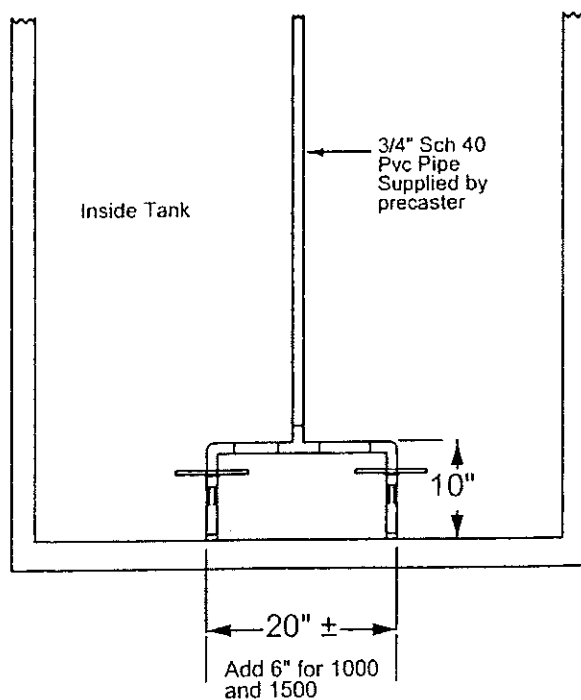

**FIGURE 6**

**APPENDIX E**  
**MODEL SERIES**  
**SPECIFICATIONS, DRAWINGS AND PROCESS DESCRIPTION**

This Space Intentionally Left Blank.

The Aqua Aire models AA500T, AA500, AA600, AA750T, AA750, AA1000 and AA1500 are rectangular configurations comprised of an aeration mixing compartment and a clarifier compartment. These compartments are partitioned by an internal dividing wall in the treatment plant.

The Aqua Aire models AA500-32 and AA500-35 are three compartment rectangular configurations partitioned by internal dividing walls in the treatment plant. They are comprised of a forward pre-treatment tank, a center aeration mixing zone and a settling or clarifier compartment. Wastewater first enters the pre-treatment tank compartment of the plant, then gravity flows through a 4" SDR 35 PVC inlet to the center aeration mixing zone. The mixed liquid then enters the settling or clarifier compartment and continues to flow upward to the plant's discharge pipe.

The Aqua Aire models AA500-3575, AA500-4050 and AA500-4075 are four compartment rectangular configurations partitioned by internal dividing walls in the treatment plant. They are comprised of a forward pre-treatment tank, an aeration mixing zone, a settling or clarifier compartment and a rear pump tank compartment. Wastewater first enters the pre-treatment tank compartment of the plant, then gravity flows through a 4" SDR 35 PVC inlet to the aeration mixing zone. The mixed liquid then enters the settling or clarifier compartment and continues to flow upward to the discharge pipe. From the plant's discharge pipe, the final effluent then passes through a disinfection or chlorination devise into the pump tank compartment for storage and contact mixing. The treated and disinfected effluent is then safely discharged, via an application pump, to a surface spray, subsurface drip, low pressure dose or absorptive mound disposal area. The results of the Aqua Aire process is a clear, odorless effluent discharge, which meets and exceeds state and national water quality standards.

ECOLOGICAL TANKS, INC.

# **AQUA AIRE™**

## **Concrete Class I Wastewater Treatment Plants**

### **Installation, Operation, Maintenance and Trouble-Shooting Manual for Distributors, Installers, and Maintenance Providers**

#### **MODELS**

<b>AA500T</b>	<b>AA500-3575</b>	<b>AA750T</b>
<b>AA500</b>	<b>AA500-4050</b>	<b>AA750</b>
<b>AA500-32</b>	<b>AA500-4075</b>	<b>AA1000</b>
<b>AA500-35</b>	<b>AA600</b>	<b>AA1500</b>

#### **“Copyright Notice”**

No part of this publication may be reproduced, stored in any retrieval system, or transmitted in any form or by any means, electronic, mechanical, photocopying, recording, or otherwise without the prior written permission of Ecological Tanks, Inc.

Mfg. By  
Ecological Tanks, Inc.  
2247 Hwy 151 North  
Downsville, LA 71234  
PH (318) 644-0397 \* FAX (318) 644-7257



Certified to ANSI/NSF Standard 40

© 2002

AquaAire Sewage Treatment System  
 Model AA750T  
 Two Piece Tank

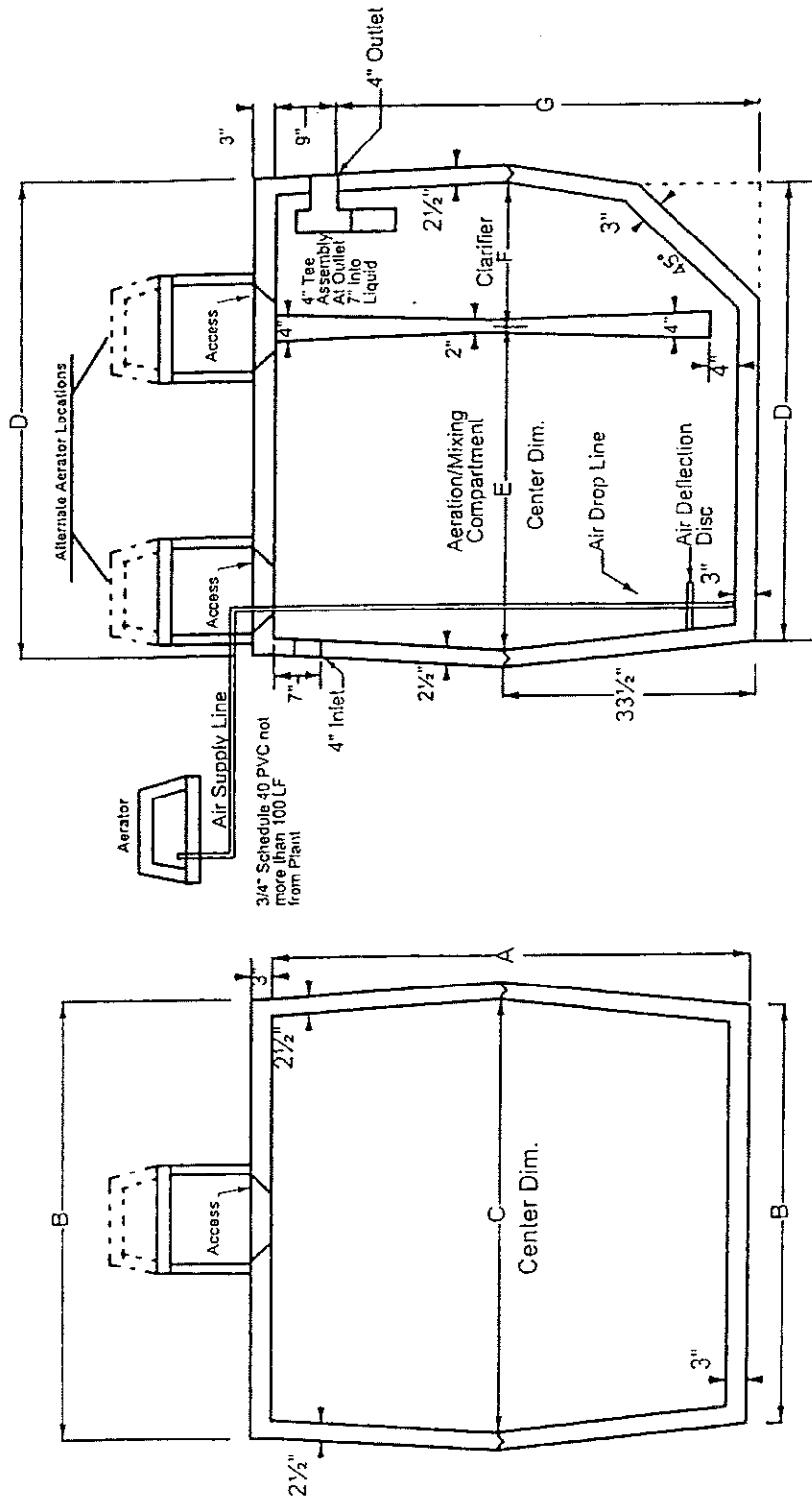

Schedule

Designation	Trim Capacity	BOD Loading	Total Volume	Aeration Volume	Clarifier Volume	A	B	C	D	E	F	G
AA750T	750GPD	1.85	1025	775	250	64	60	57	94	63 1/2	27 1/2	55

FIGURE 2

ECOLOGICAL TANKS, INC.

# AQUA AIRE™

Concrete Class I Wastewater Treatment Plants

## OWNER'S MANUAL

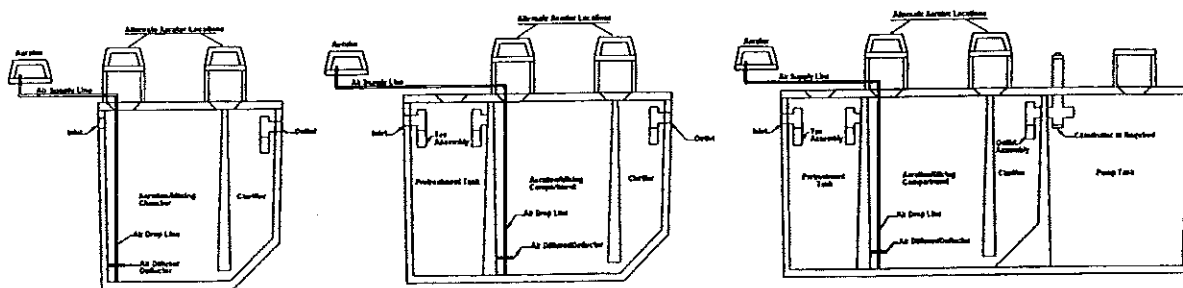

Patent Pending

- |                                       |   |   |
|---------------------------------------|---|---|
| <input type="checkbox"/> Model AA500  | <input type="checkbox"/> Model AA500-32 | <input type="checkbox"/> Model AA500-3575 |
| <input type="checkbox"/> Model AA500T | <input type="checkbox"/> Model AA500-35 | <input type="checkbox"/> Model AA500-4050 |
|                                       |   | <input type="checkbox"/> Model AA500-4075 |

### "Copyright Notice"

No part of this publication may be reproduced, stored in any retrieval system, or transmitted in any form or by any means, electronic, mechanical, photocopying, recording, or otherwise without the prior written permission of Ecological Tanks, Inc.



Mfg. By  
 Ecological Tanks, Inc.  
 2247 Hwy 151 North  
 Downsville, LA 71234  
 PH (318) 644-0397 \* FAX (318) 644-7257

Certified to ANSI/NSF Standard 40

© 2002

### Aqua Aire Flow Diagram

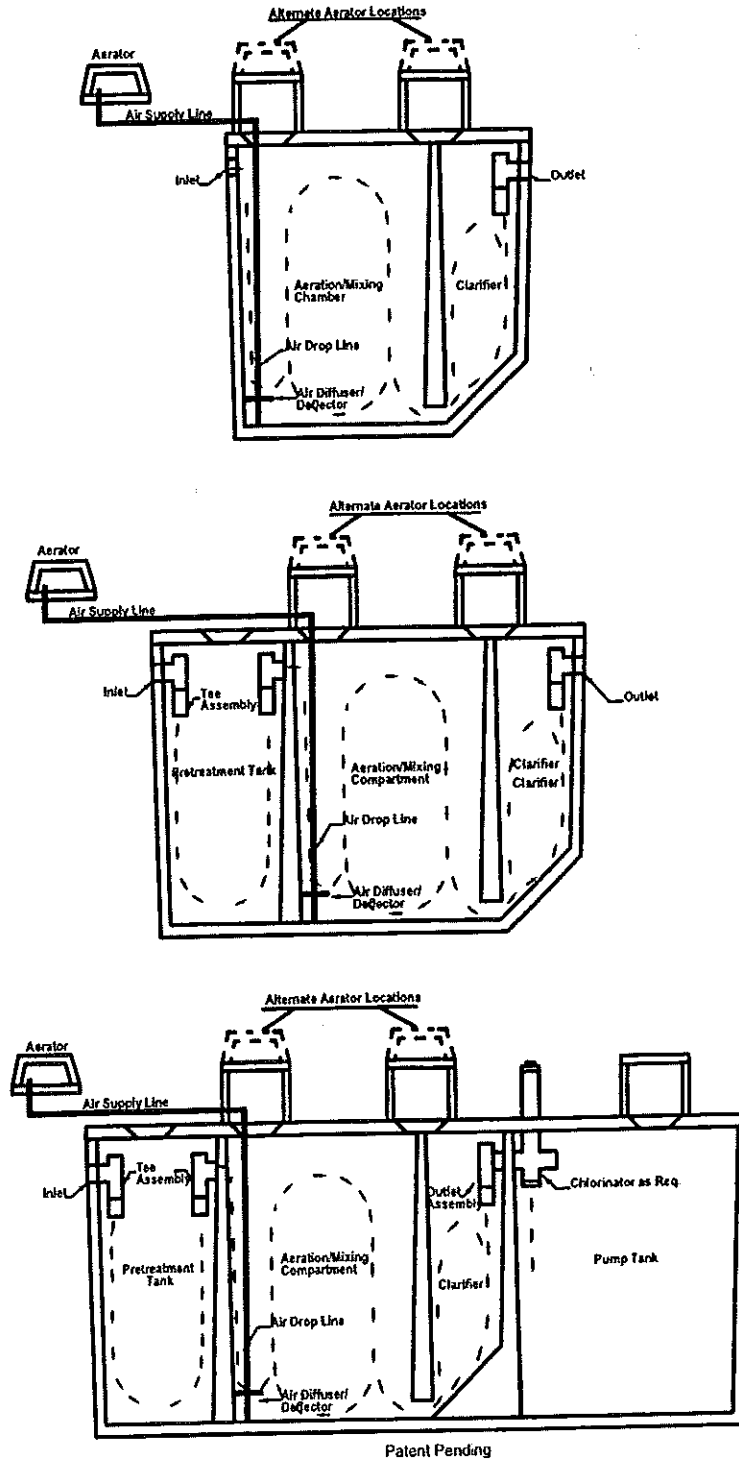

Ecological Tanks, Inc.

03/2002

ECOLOGICAL TANKS, INC.

# AQUA AIRE™

Concrete Class I Wastewater Treatment Plants

## OWNER'S MANUAL

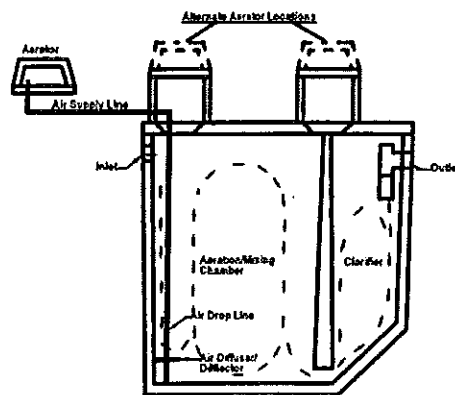

Patent Pending

- Model AA600
- Model AA750
- Model AA1000
- Model AA1500

### "Copyright Notice"

No part of this publication may be reproduced, stored in any retrieval system, or transmitted in any form or by any means, electronic, mechanical, photocopying, recording, or otherwise without the prior written permission of Ecological Tanks, Inc.



Mfg. By  
Ecological Tanks, Inc.  
2247 Hwy 151 North  
Downsville, LA 71234  
PH (318) 644-0397 \* FAX (318) 644-7257

Certified to ANSI/NSF Standard 40

© 2002

### Aqua Aire Flow Diagram

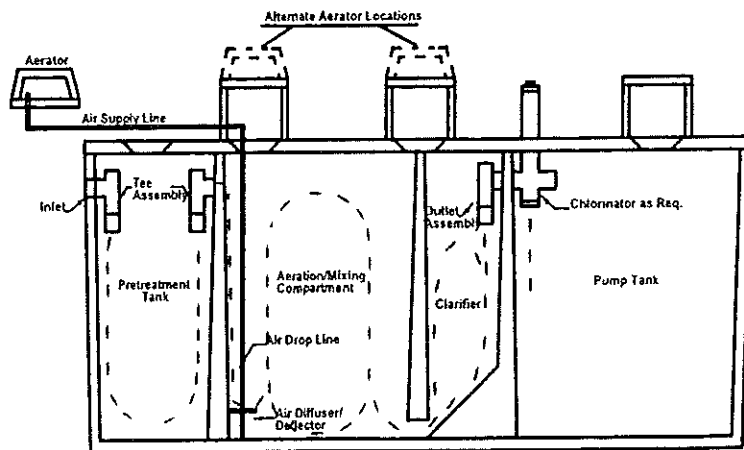
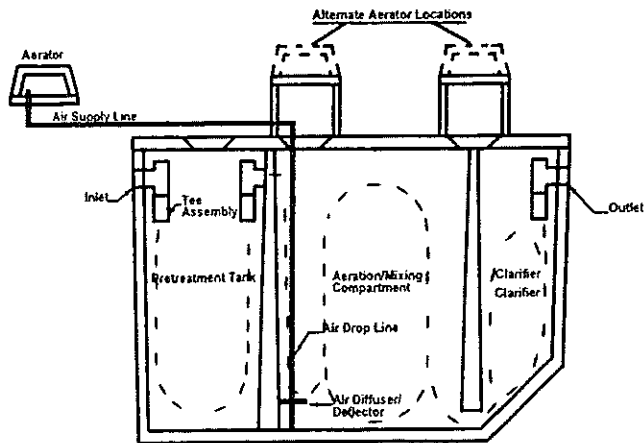
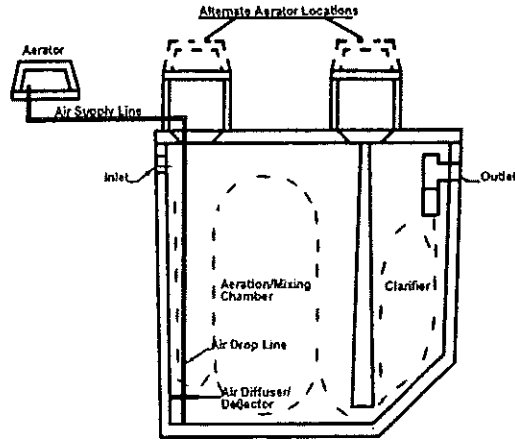

Patent Pending

**DESIGN COMPONENTS AND MATERIALS**  
NUMBERS CORRESPOND WITH DESIGN DRAWINGS

- ① Aerator (see specifications)
- ② Aeration Tank and Lid - Reinforced Concrete - 4000 PSI
- ③ Aerator Cover and Base - Concrete, Poly or Fiberglass
- ④ Risers and Riser Top - Concrete, Poly or Fiberglass  
Concrete Riser Top to be min. 65lbs, Poly or Fiberglass Riser Top to be fastened so as to only be removed with specialized tools
- ⑤ Air Diffusion System - Schedule 40 PVC
- ⑥ 4" Tee Assembly Outlet - SDR 35 PVC

**AquaAire Sewage Treatment System  
 Models AA500,600,750,1000,1500 In One Piece  
 Tank with Lid**

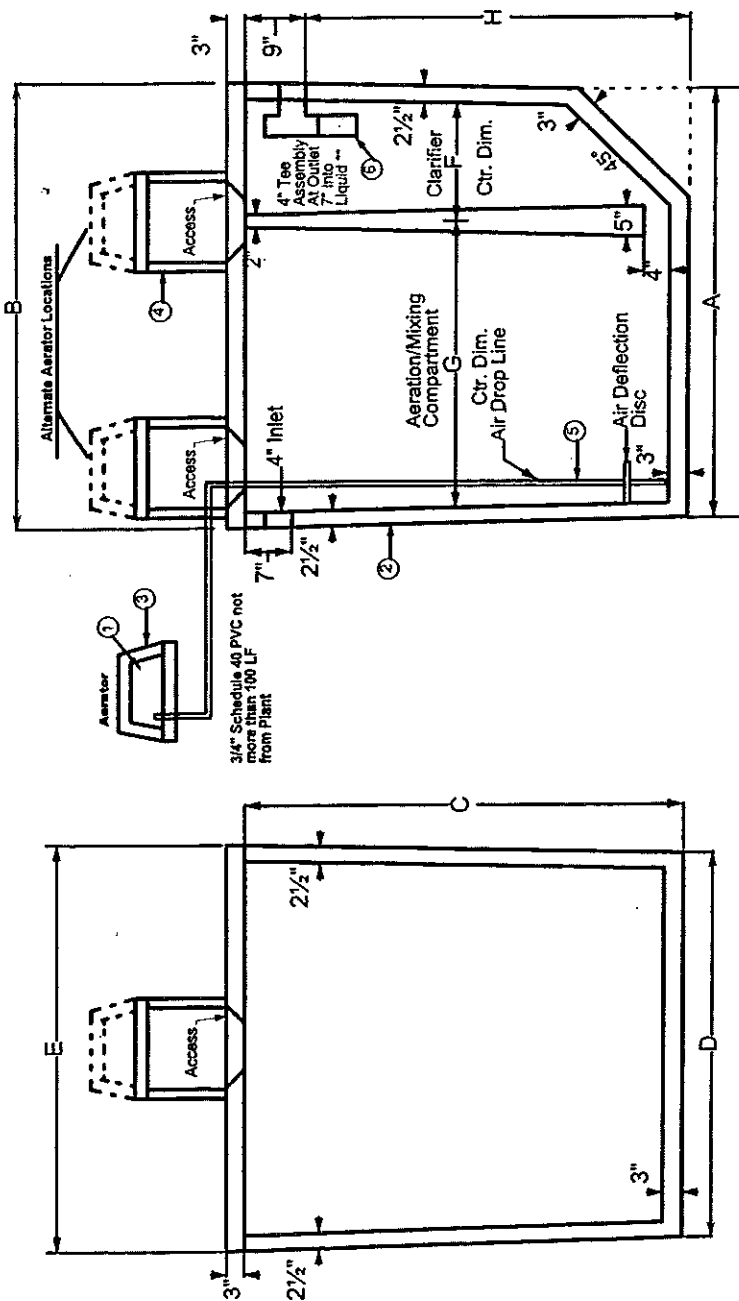

\*\*\*Extend 10" into liquid depth on AA1500

Schedule

Designation	Trrmt Capacity	BOD Loading	Total Volume	Aeration Volume	Clarifier Volume	A	B	C	D	E	F	G	H
AA500	500GPD	1.25	748	560	188	68	71	64	60	63	18 3/4	45 3/4	55
AA600	600GPD	1.50	857	642	215	77 1/2	80 1/2	64	60	63	21 1/4	52 1/4	55
AA750	750GPD	1.85	1076	801	275	95 1/2	98 1/2	64	60	63	29 1/4	64 1/4	55
AA1000	1000GPD	2.50	1420	1063	357	111	114	64	71	74	35 3/4	71 1/4	55
AA1500	1500GPD	3.75	2216	1699	517	131	134	74	75	78	37 3/4	89 3/4	65

FIGURE 1

**AquaAire Sewage Treatment System  
 Model AA500-35  
 AA500 with 350 Gallon Pretreatment Tank  
 One Piece with Lid**

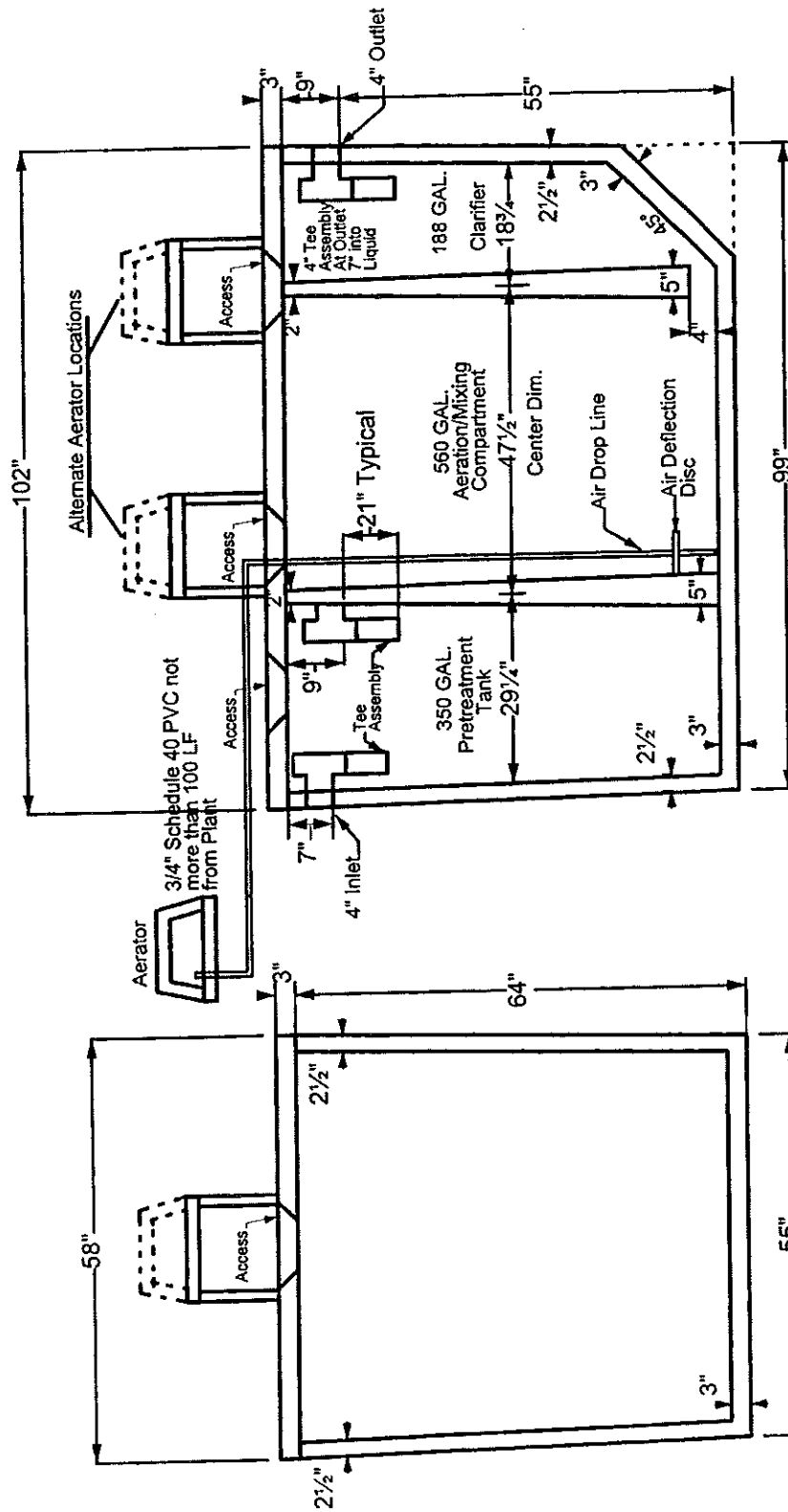
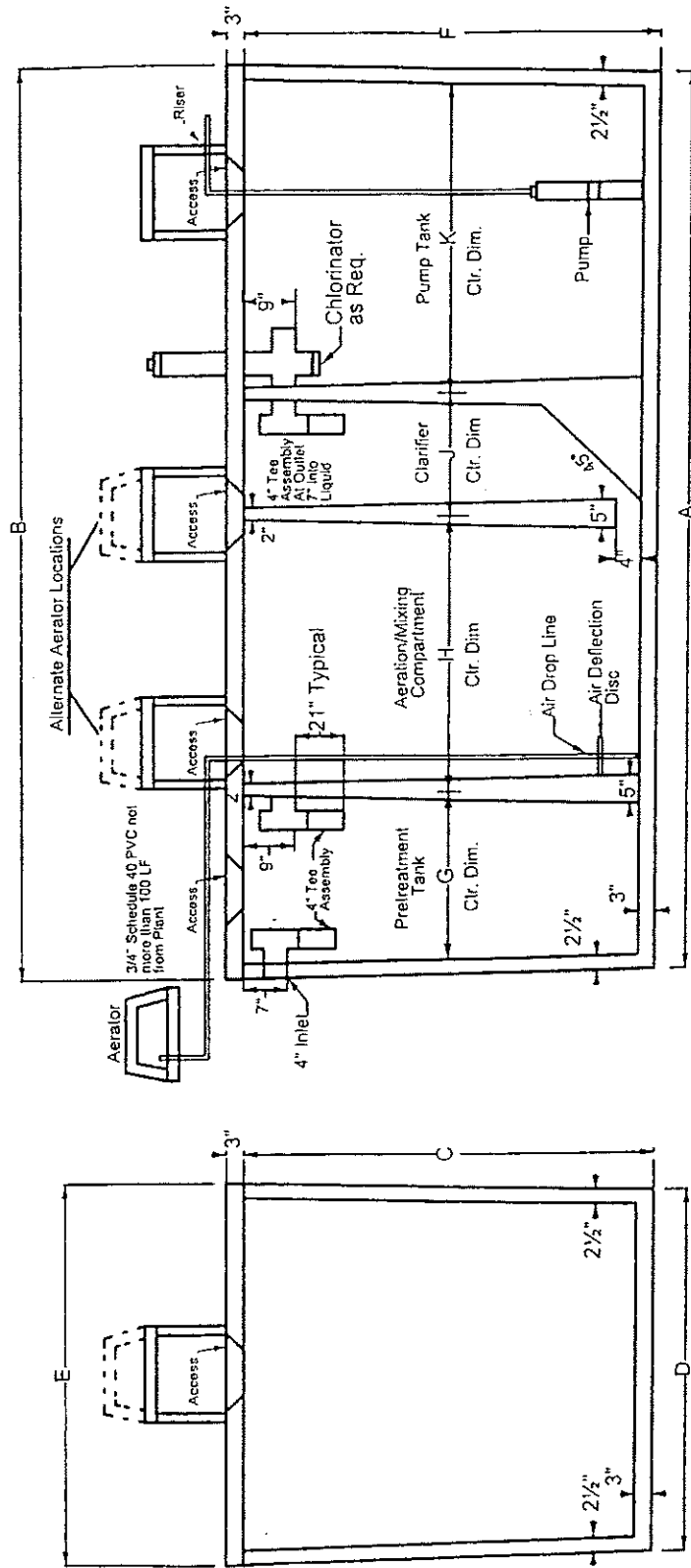

FIGURE 3

03/2002

Ecological Tanks, Inc.

**AquaAire Sewage Treatment System  
 Models AA500-3575, AA500-4075, AA500-4050  
 One Piece with Lid**



Schedule

Designation	Trim Capacity	Total Volume	Aeration Volume	Clarifier Volume	A	B	C	D	E	F	G	H	J	K	Pre Tank Volume	Pump Tank Volume
AA500-3575	500 GPD	748	560	188	162 1/2	165 1/2	64	60	63	64	29 1/2	47 1/2	20 1/2	61 1/2	350 GAL	750 GAL
AA500-4075	500 GPD	748	560	188	167 1/2	170 1/2	64	60	63	64	34 1/2	47 1/2	20 1/2	61 1/2	400 GAL	750 GAL
AA500-4050	500 GPD	748	560	188	148	151	64	60	63	64	34 1/2	47 1/2	20 1/2	42 1/2	400 GAL	500 GAL

FIGURE 5

03/14/2002

Ecological Tanks, Inc.

Aqua Aire Sewage Treatment Plant  
 Model AA500-32  
 AA500T w/325 Gal. PreTank  
 Two Piece Tank

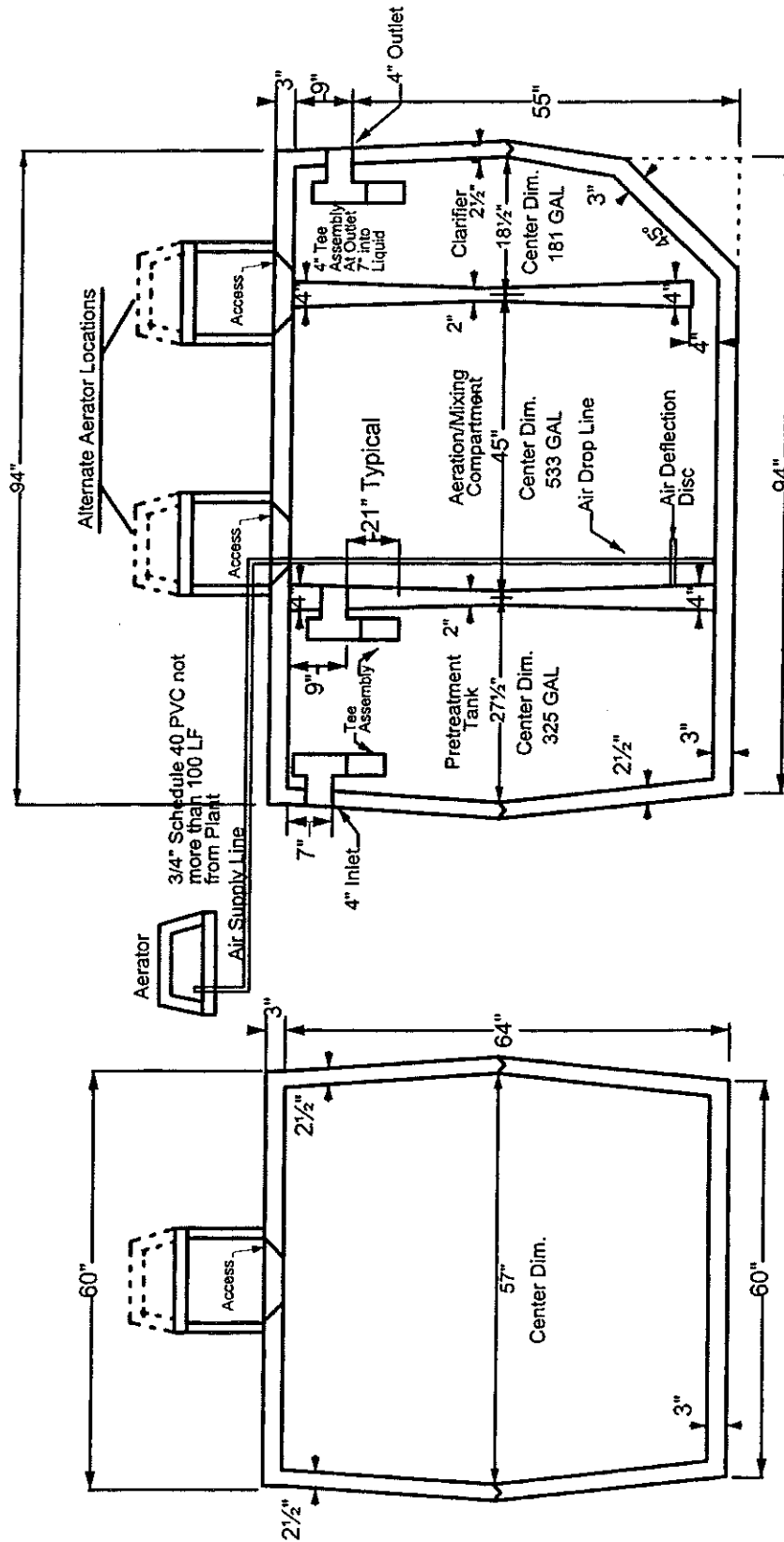

03/13/2002

Ecological Tanks, Inc.

### Aqua Aire Diffusion System For AA500, 600, 750, 1000 and 1500

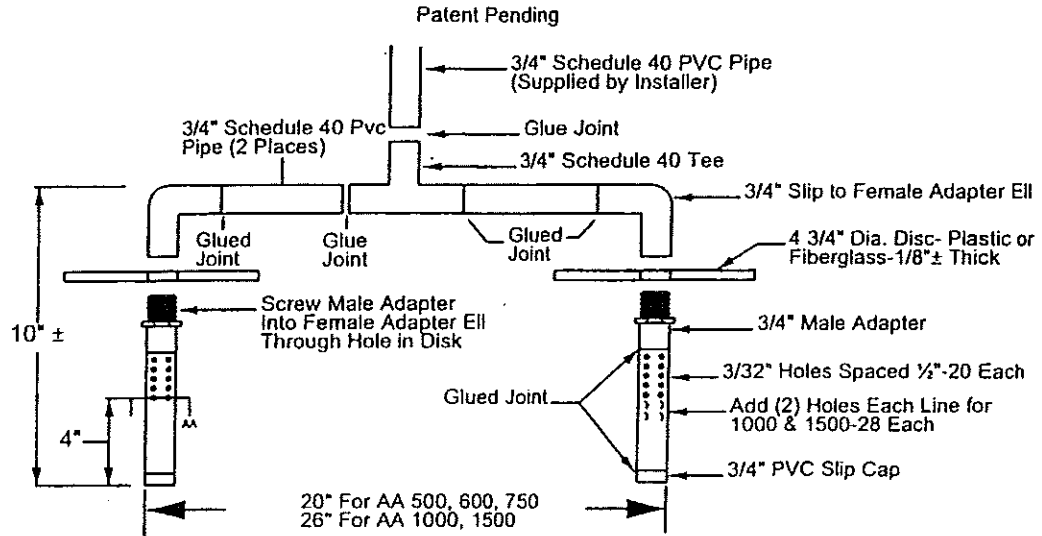

View AA

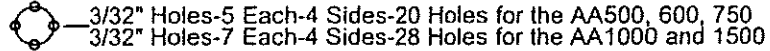

In-Tank View

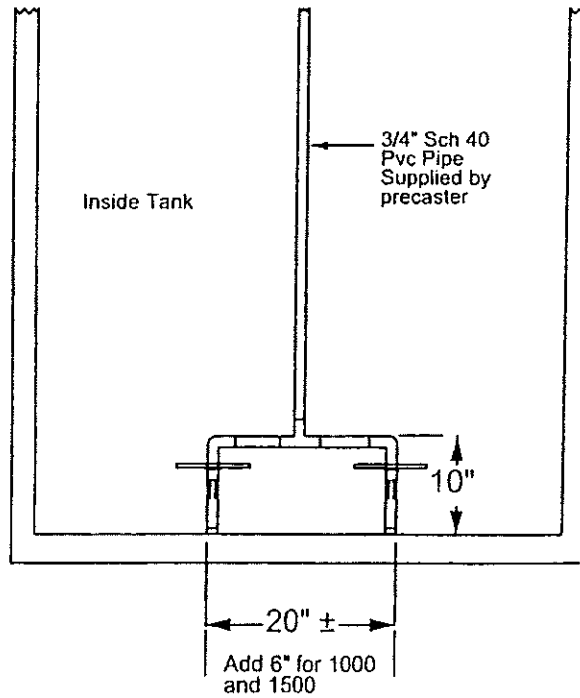

This Space Intentionally Left Blank

This Space Intentionally Left Blank

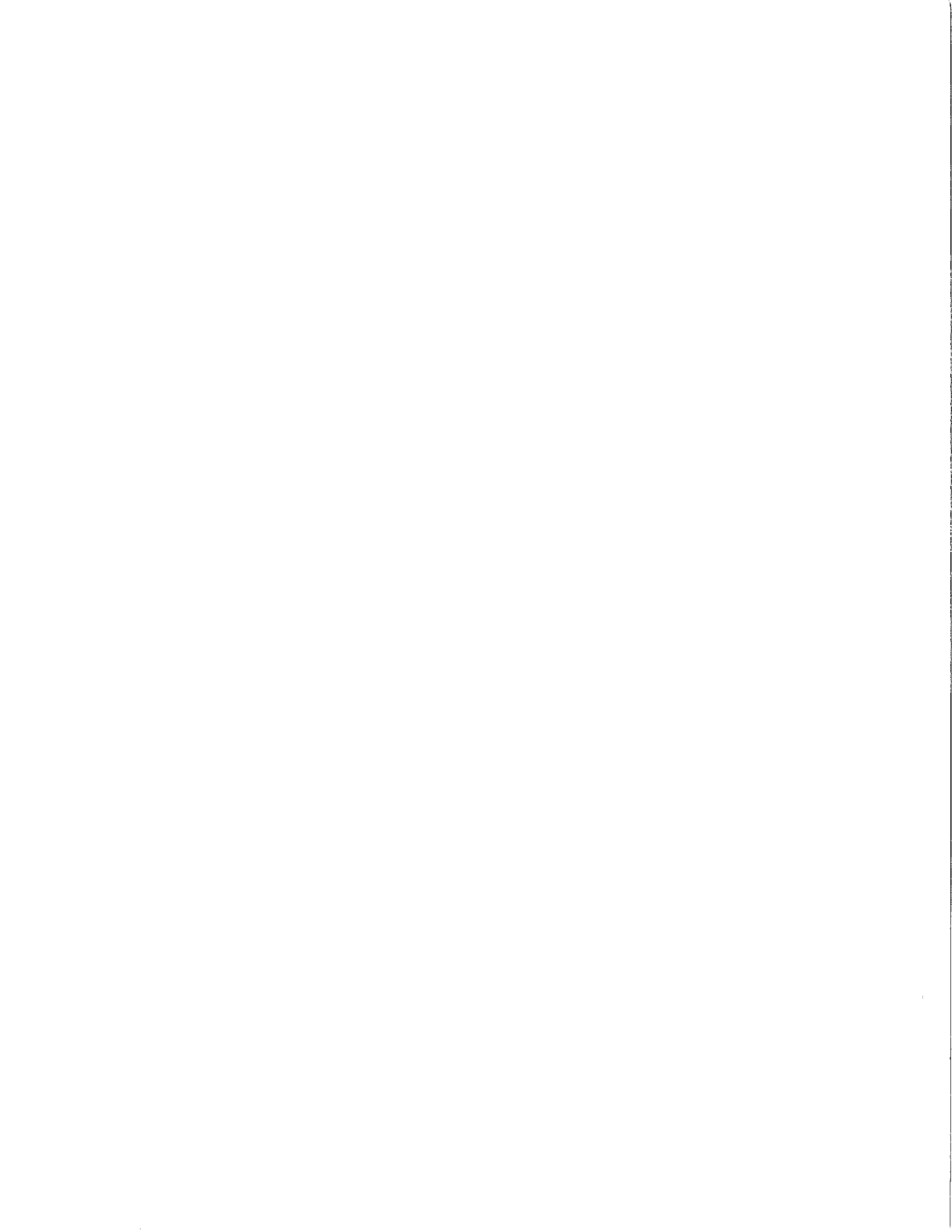

BAYLOR  
UNIVERSITY

9-15-03

Attn: George Johnson  
Ecological Tanks, Inc.  
2247 Hwy 151 N.  
Downsville, LA 71234

Dear George;

The accompanying report is the synopsis of the nutrient reduction evaluation performed on the Aqua Aire system in 2002. We have double checked to ensure that the quality of the data and the validity of the analysis are accurate. If you have any questions, or concerns please contact us at your earliest convenience and David Jumper or I will be glad to discuss the report with you.

Sincerely,



Joe C. Yelderman Jr.  
Director  
Baylor Wastewater Research Program

Cc: David Jumper



**OSSF Nutrient Reduction Report  
for the  
Ecological Tanks, Inc.  
Aqua Aire  
Wastewater Treatment System  
Completed by the  
Baylor University  
Wastewater Research Program**

**September 15, 2003**



## Introduction

The following report details the results of extended effluent sampling and evaluation of the performance of the Aqua Aire wastewater treatment system by the Baylor University Wastewater Research Program to determine reduction of nutrient levels found in a documented raw influent wastewater stream.

Nutrients measured for the report include; Total Kjeldahl Nitrogen (TKN), ammonia, nitrate, nitrite, total phosphorous and phosphate. In addition, fecal coliform bacteria counts were made on the effluent only. TKN measures the total organic nitrogen and ammonia nitrogen. TKN plus nitrates and nitrites equal the total nitrogen in the influent or the effluent. In the decomposition of wastewater, organic nitrogen is converted into ammonia nitrogen, which in turn is converted into nitrate and nitrite. Nitrite is usually the lowest concentration and is sometimes omitted from the analysis of wastewater but is included in this study.

The mean, maximum, and minimum values in the raw and treated effluent for each of these parameters are reported in tabular and graphic form and may be found in the appendices included.

It is pertinent to note that the evaluation reported here took place during a period of time when the Aqua Aire system was undergoing an evaluation under the NSF/ANSI Standard 40 certification testing protocol at the Baylor University Testing and Certification test facility in Waco, Texas. The test was conducted from April 15, 2002 until December 24, 2002 and samples were taken on a weekly basis.

Systems undergoing this test protocol are dosed every day with the full gallons per day dose commensurate with the system daily rated capacity (in this case the Aqua Aire system was dosed with exactly 500 gallons per day). Notably the Standard 40 protocol also includes a six-month evaluation period of daily dosing and four stress sequences of non-ideal dosing conditions, designed to test the system's ability to perform under adverse conditions. Systems installed in the field under normal conditions are typically considered to receive somewhat less daily dosing volumes.

## Executive Summary

Significant reductions occurred in total nitrogen and organic nitrogen. Specifically, phosphorous, phosphate, TKN and ammonia were reduced but nitrites and nitrates increased as the TKN and ammonia were converted to nitrates and nitrites. Variations or peaks do not seem to correlate directly with stress periods and weekly analyses may not provide enough detail to evaluate the specific effects of individual stresses. However, the stress periods did not appear to impact the treatment system's performance in overall reduction of nutrient levels in the treatment processes. Fluctuations in dosing and influent values may have had a greater impact on effluent concentrations. Generally, the system reduced nutrients and average effluent nutrient values were not at levels of health concern.

## Summary Table

<u>Raw Influent</u>	<u>mg/l</u>	<u>Treated Effluent</u>	<u>mg/l</u>	
TKN	29.76	TKN	12.78	
Ammonia	16.60	Ammonia	08.79	
Nitrate	01.87	Nitrate	06.13	
Nitrite	00.29	Nitrite	00.26	<u>Reduction</u>
Total N	31.92	Total N	19.17	40 %
Total Organic N	13.16	Total Organic N	03.99	70 %
Phosphorous	08.20	Phosphorous	06.69	18 %
Phosphate	06.00	Phosphate	04.40	27 %



### **Fecal Coliform**

Fecal coliform bacteria are often of concern in evaluating water quality. This study calculated the numbers of colonies per 100 ml of sample from the effluent only and the numbers varied widely from 10-96000 colonies/100ml. The average (mean) number of colonies/100ml was approximately 12800 (12774) but the median was 2700. The wide variability produced a standard deviation of 21500 (21546) colonies/100ml, which was even greater than the average or the median values. The low and high values for the treated effluent were interspersed throughout the study and in a two-week period from October 21, 2002, to November 4, 2002, the counts went from 135 colonies/100ml to 19000 colonies/100ml and back to only 50 colonies/100ml. Graphical and tabular data for fecal coliform bacteria are included in the appendices.

### **Total Kjeldahl Nitrogen (TKN)**

The raw influent averaged 29.8 mg/l TKN (mean) and ranged from a low of 2.18 mg/l TKN on April 22, 2002 to a high of 64.60 mg/l TKN on August 26, 2002. Only two (2) of 35 samples exceeded 50 mg/l. The treated effluent averaged 13 mg/l TKN (mean) and ranged from a low of .57 mg/l TKN on May 28, 2002, to a high of 49.80 mg/l TKN on June 17, 2002. The median TKN value for the treated effluent was 7.0 mg/l and although this value is almost 6 mg/l less than the mean value for the treated effluent it is more than 20 mg/l less than the mean value for the raw effluent. The lowest values for the treated effluent were in May 2002 when values were less than 2 mg/l but beginning in the middle of June 2002, values exceeded 10 mg/l until September 9, 2002. The difference between the mean raw influent value and the mean effluent value is 16.7 mg/l, which represents a decrease of over 57%. On only 3 occasions did the treated effluent values exceed the raw influent values and one of these was the peak sample for the effluent. Graphical and tabular data for TKN are included in the appendices.

### **Ammonia**

The raw influent averaged 17 mg/l of ammonia (mean) and ranged from a low of .05 mg/l ammonia on April 22, 2002 to a high of 63.5 mg/l ammonia on September 30, 2002. Only 1 in 35 samples exceeded 50 mg/l. The treated effluent averaged 8.8 mg/l ammonia (mean) and ranged from a low of .05 mg/l ammonia on 8 different occasions to a high of 33.90 mg/l ammonia on August 26, 2002. The median ammonia value for the treated effluent was 4.2 mg/l and this value is almost 4.5 mg/l less than the mean value for the treated effluent and it is more than 14.5 mg/l less than the mean value for the raw influent. The lowest values for the treated effluent were in May 2002 when values averaged .05 mg/l but beginning in July, values exceeded 10 mg/l until September 2002. The difference between the mean raw values for ammonia and the mean treated effluent values is approximately 8 mg/l, which is a decrease of 47 percent. The treated effluent values exceed the raw influent values on only one occasion, which was the highest effluent value, recorded (August 26, 2002). Graphical and tabular data for ammonia are included in the appendices.

### **Nitrate**

Nitrate is the byproduct of nitrification of the ammonia. The raw influent averaged 1.9 mg/l of nitrate (mean) and ranged from a low of .05 mg/l nitrate on numerous occasions to a high of 31.50 mg/l nitrate on April 15, 2002. Only 1 in 34 samples exceeded 10 mg/l and only 3 values were greater than 5 mg/l. The treated effluent averaged 6.1 mg/l nitrate (mean) and ranged from a low of .05 mg/l nitrate on several occasions to a high of 20.20 mg/l nitrate on May 5, 2002. The median nitrate value for the treated effluent was 4.5 mg/l. This value is almost 2 mg/l less than the mean value for the treated effluent but it is more than 2 mg/l greater than the mean value for the raw influent. The lowest values for the treated effluent were in July and August 2002, when values were less than 3 mg/l but in May and October values averaged over 10 mg/l. The difference between the mean raw values for nitrate and the mean treated effluent values is an increase of 4.2 mg/l. Graphical and tabular data for nitrate are included in the appendices.

### **Nitrite**

Nitrite is the byproduct of nitrification of the ammonia. The raw influent averaged .29 mg/l of nitrite (mean) and ranged from a low of .05 mg/l nitrite on numerous occasions to a high of 1.00 mg/l nitrite on May 28, 2002. The treated effluent averaged .26 mg/l nitrite (mean) and ranged from a low of .05 mg/l nitrite on numerous occasions to a high of 1.19 mg/l nitrite on April 29, 2002. The median nitrite value for the treated effluent was .10mg/l and although this value is about .15mg/l less than the mean value for the treated effluent it is almost .2 mg/l less than the mean value for the raw influent. The lowest values for the treated effluent were in August and September when values were usually .05 mg/l. The cumulative average



decreased steadily from May through September and then rose abruptly August 14, 2002, when it plateaued at .26 mg/l. The difference between the mean raw values for nitrite and the mean treated effluent values is an increase of .03 mg/l. Graphical and tabular data for nitrite are included in the appendices.

#### **Nitrogen Summary**

The TKN is the sum of the ammonia nitrogen and the organic nitrogen. Therefore, the total organic nitrogen is the mean TKN value minus the mean ammonia value. The mean organic nitrogen calculated for the raw influent is 13.16 mg/l. The total nitrogen is the sum of the TKN, nitrate and nitrite. Therefore, the total mean nitrogen for the raw influent is 31.92 mg/l. The organic mean nitrogen for the treated effluent is 3.99 mg/l and the total mean nitrogen for the treated effluent is 19.17 mg/l. This is a reduction of approximately 70% of the organic mean nitrogen and approximately 40% of the total mean nitrogen.

#### **Phosphorous**

The raw influent averaged 8.20 mg/l of phosphorous (mean) and ranged from a low of 1.16 mg/l phosphorous on April 22, 2002, to a high of 18.30 mg/l phosphorous on October 14, 2002. Only 2 in 35 samples exceeded 15 mg/l. The treated effluent averaged 6.7 mg/l phosphorous (mean) and ranged from a low of .79 mg/l phosphorous on October 21, 2002, to a high of 56.10 mg/l phosphorous on June 17, 2002. The median phosphorous value for the treated effluent was 4.5 mg/l and although this value is about 2 mg/l less than the mean value for the treated effluent, it is almost 4 mg/l less than the mean value for the raw influent. The difference between the mean raw values for phosphorous and the mean treated effluent values is 1.5 mg/l, which is a decrease of over 18 percent. On several occasions the treated effluent values exceeded the raw influent values.

#### **Phosphate**

The raw influent averaged 6.0 mg/l of phosphate (mean) and ranged from a low of .93 mg/l phosphate on April 22, 2002, to a high of 13.3 mg/l phosphate on August 26, 2002. The treated effluent averaged 4.4 mg/l phosphate (mean) and ranged from a low of .48 mg/l phosphate on October 21, 2002, to a high of 14.70 mg/l phosphate on July 8, 2002. The median phosphate value for the treated effluent was 4.0 mg/l and although this value is only about .4 mg/l less than the mean value for the treated effluent, it is almost 2 mg/l less than the mean value for the raw influent. The difference between the mean raw values for phosphate and the mean treated effluent values is about 1.6 mg/l, which is a decrease of almost 27 percent. On several occasions the treated effluent values exceeded the raw influent values. Graphical and tabular data for phosphate are included in the appendices.



Appendix I  
Graphical data



# Aqua Aire Fecal Coliform

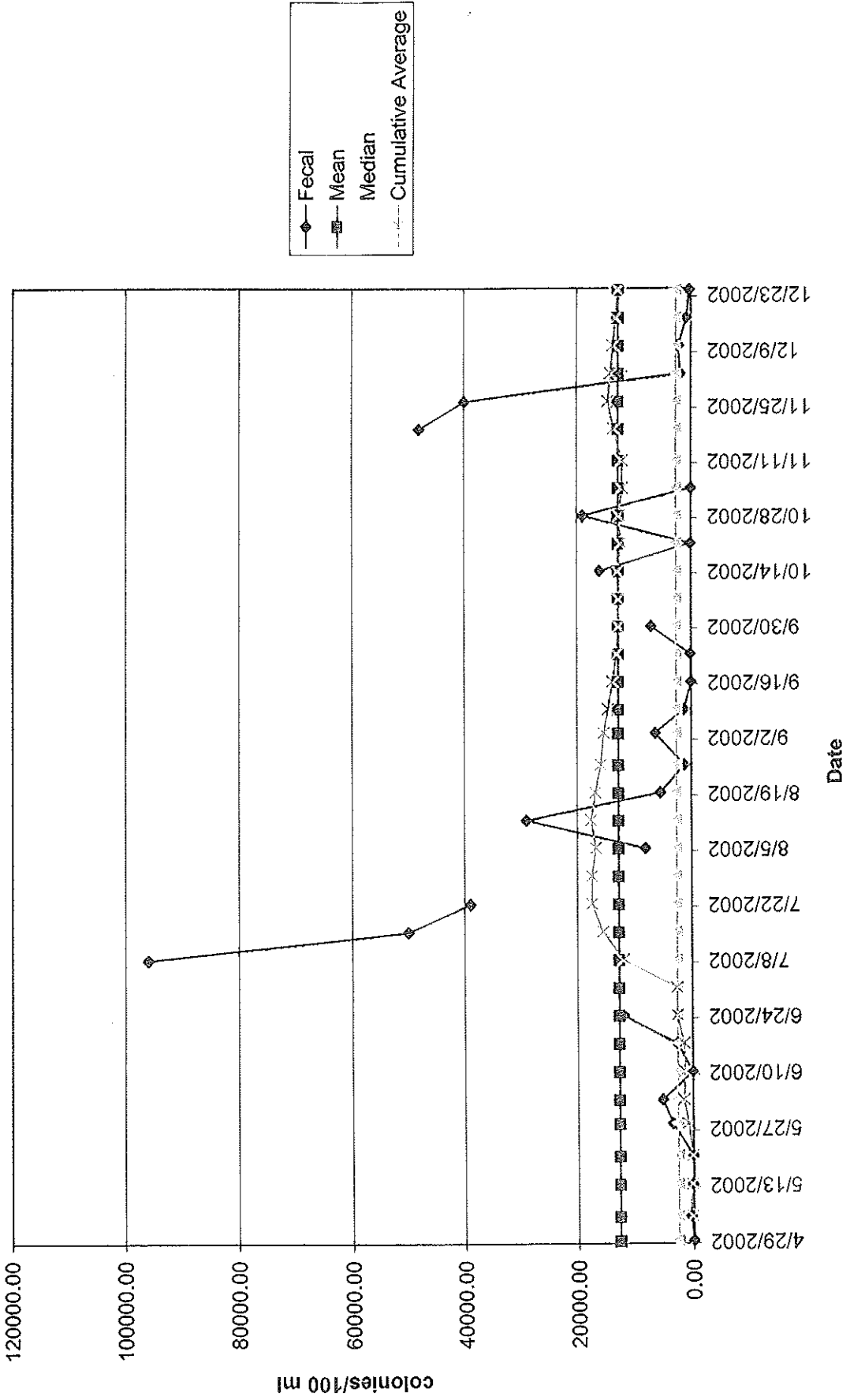



# Aqua Aire Total Kjeldahl Nitrogen

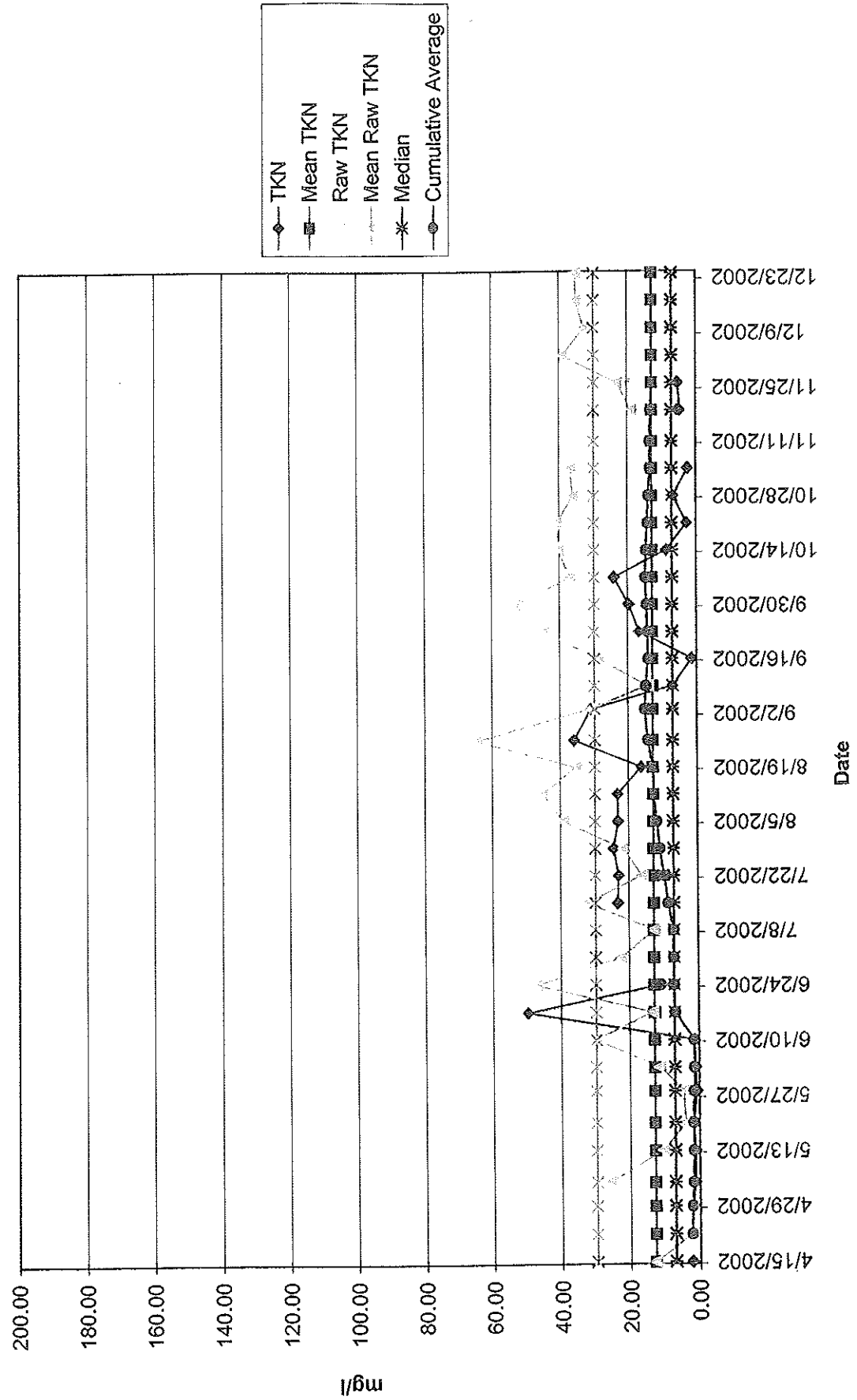



# Aqua Aire Ammonia Nitrogen

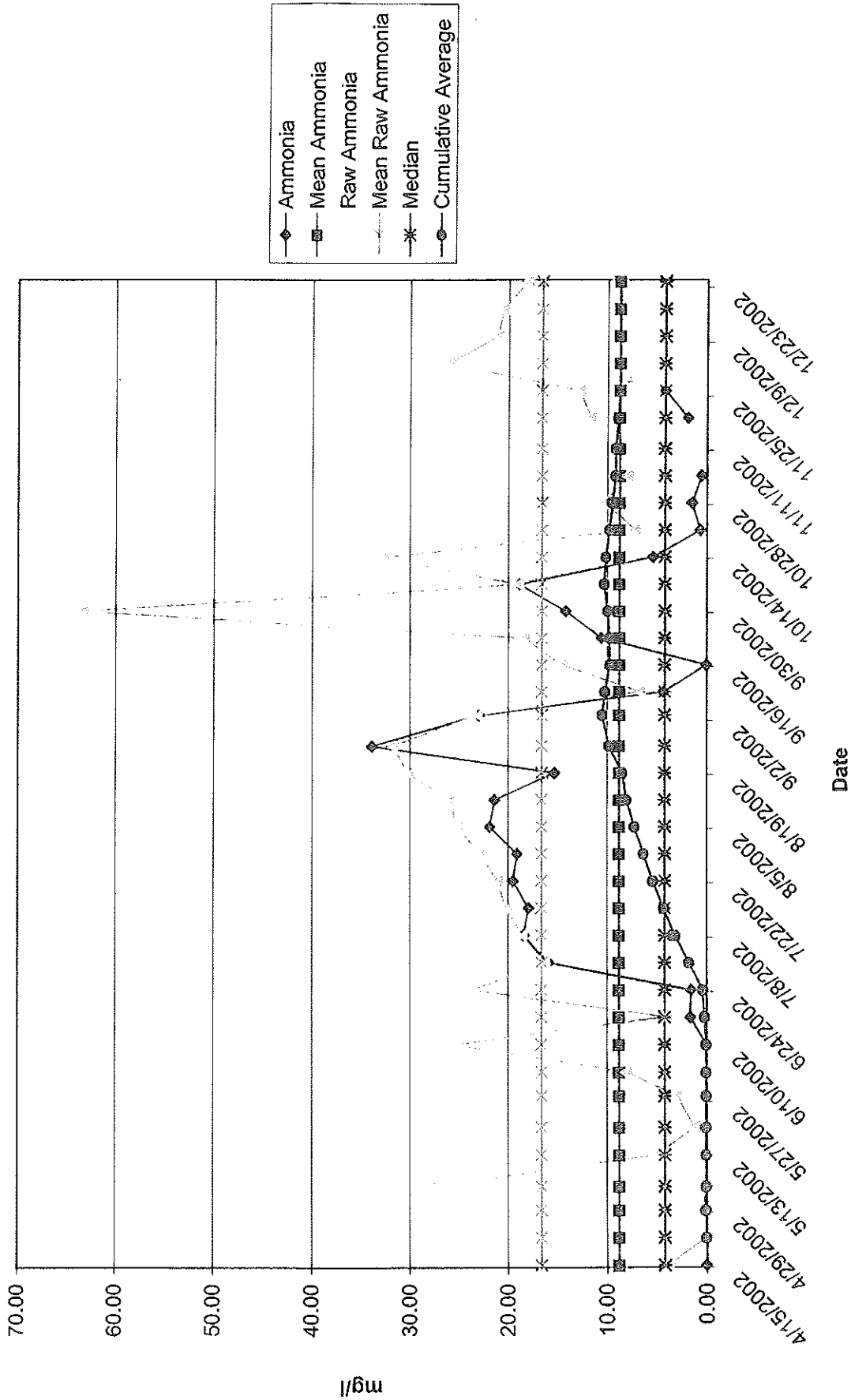



# Aqua Aire Nitrate Nitrogen

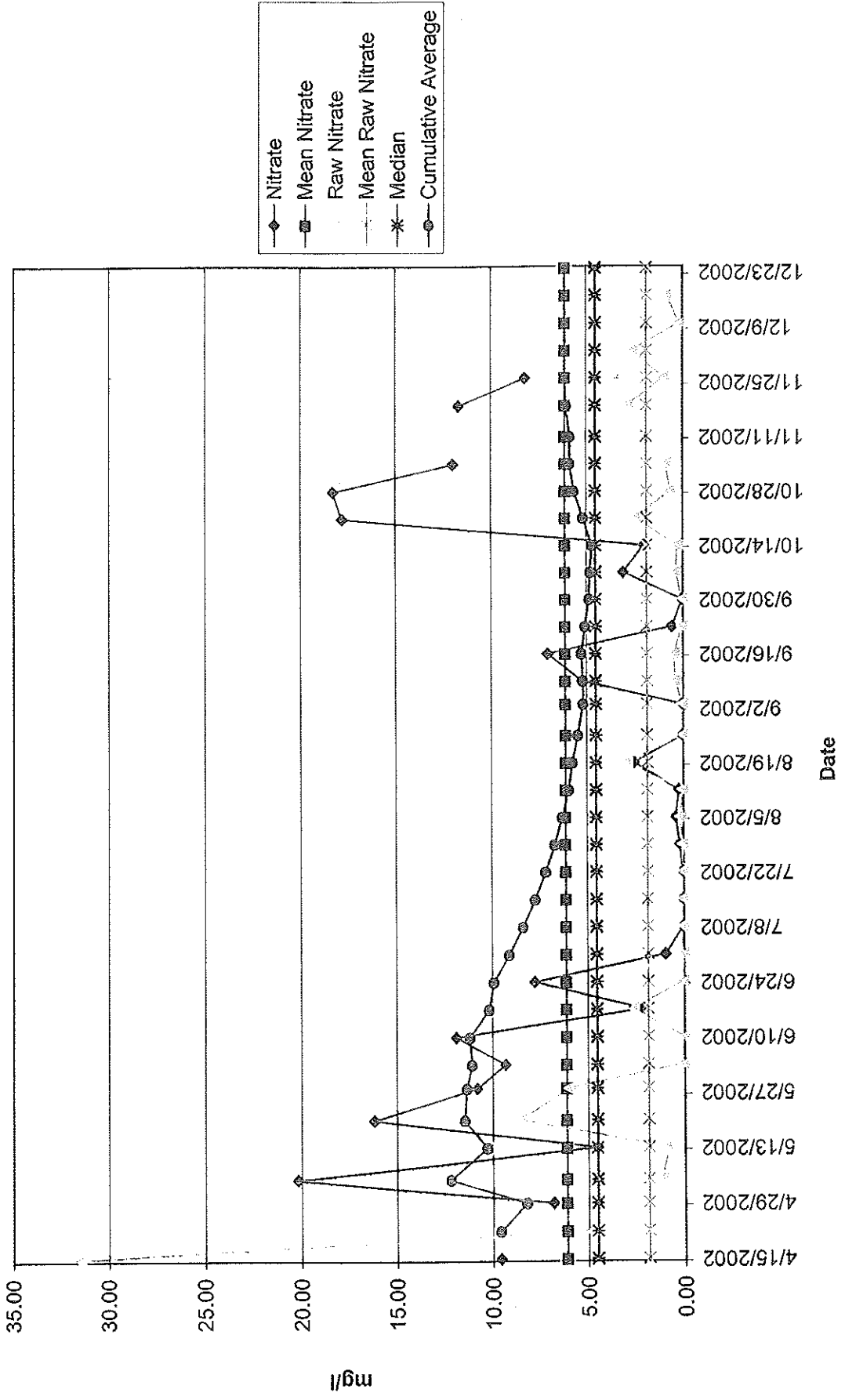



# Aqua Aire Nitrite Nitrogen

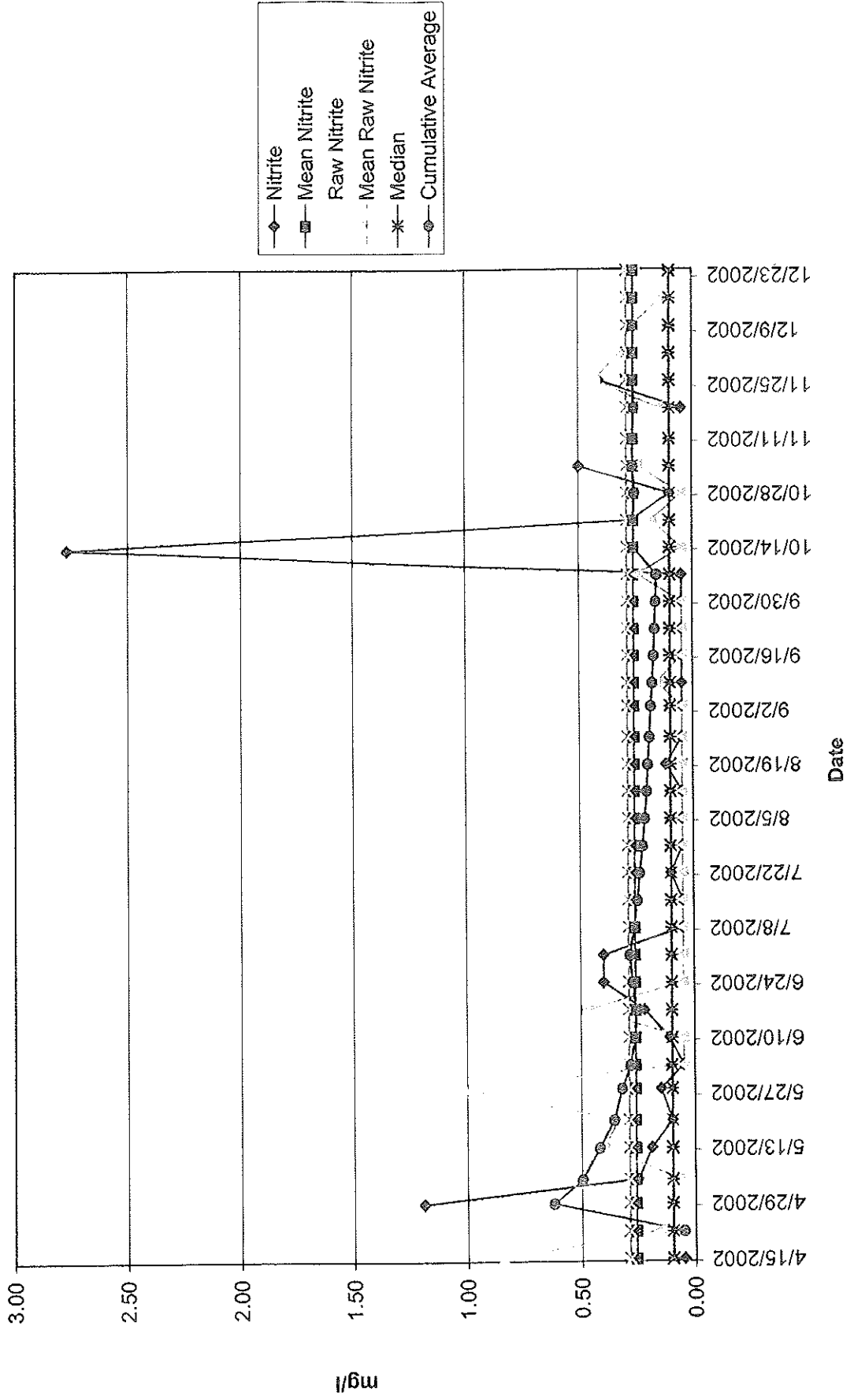



# Aqua Aire Total Phosphorus

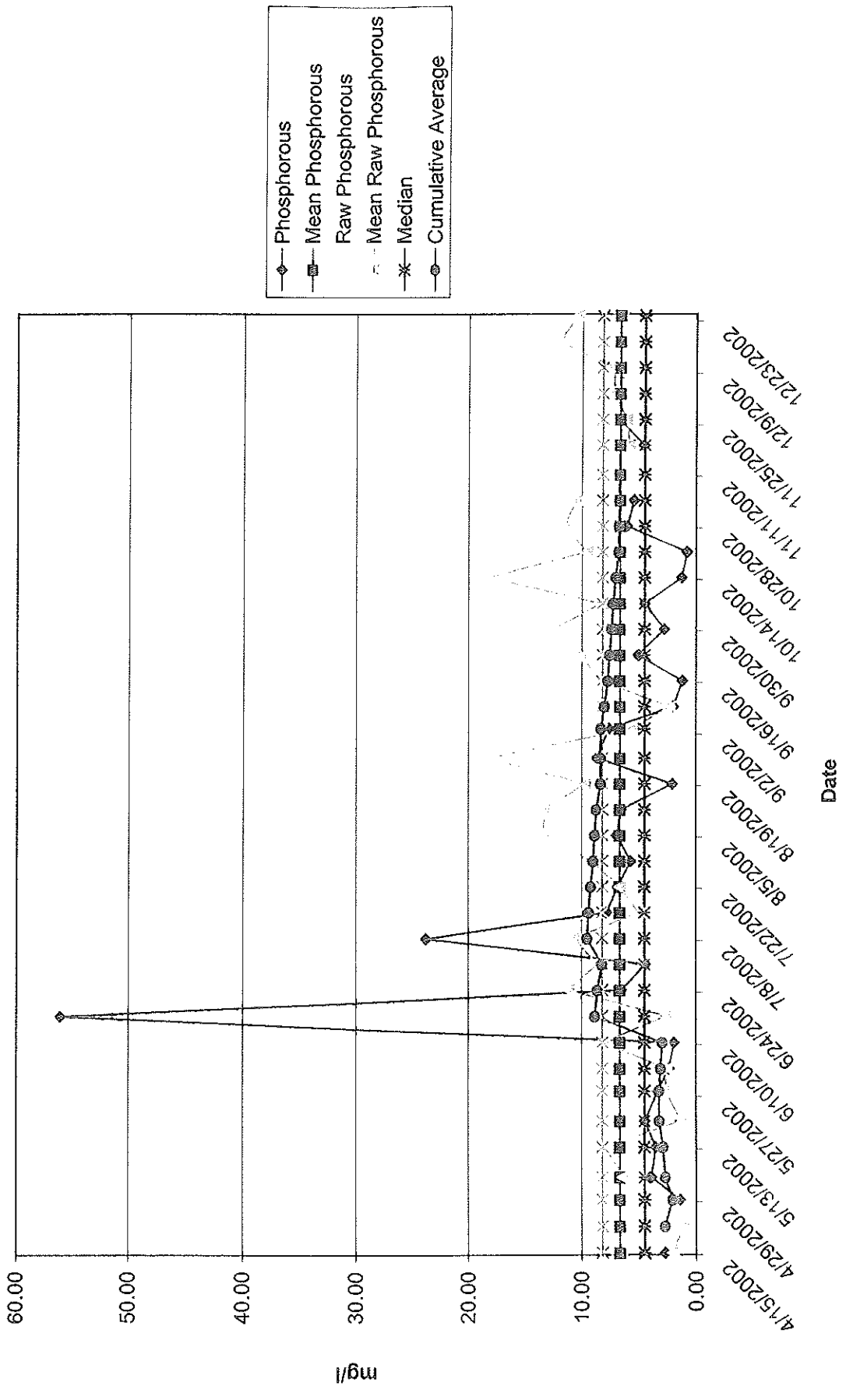



# Aqua Aire Phosphate

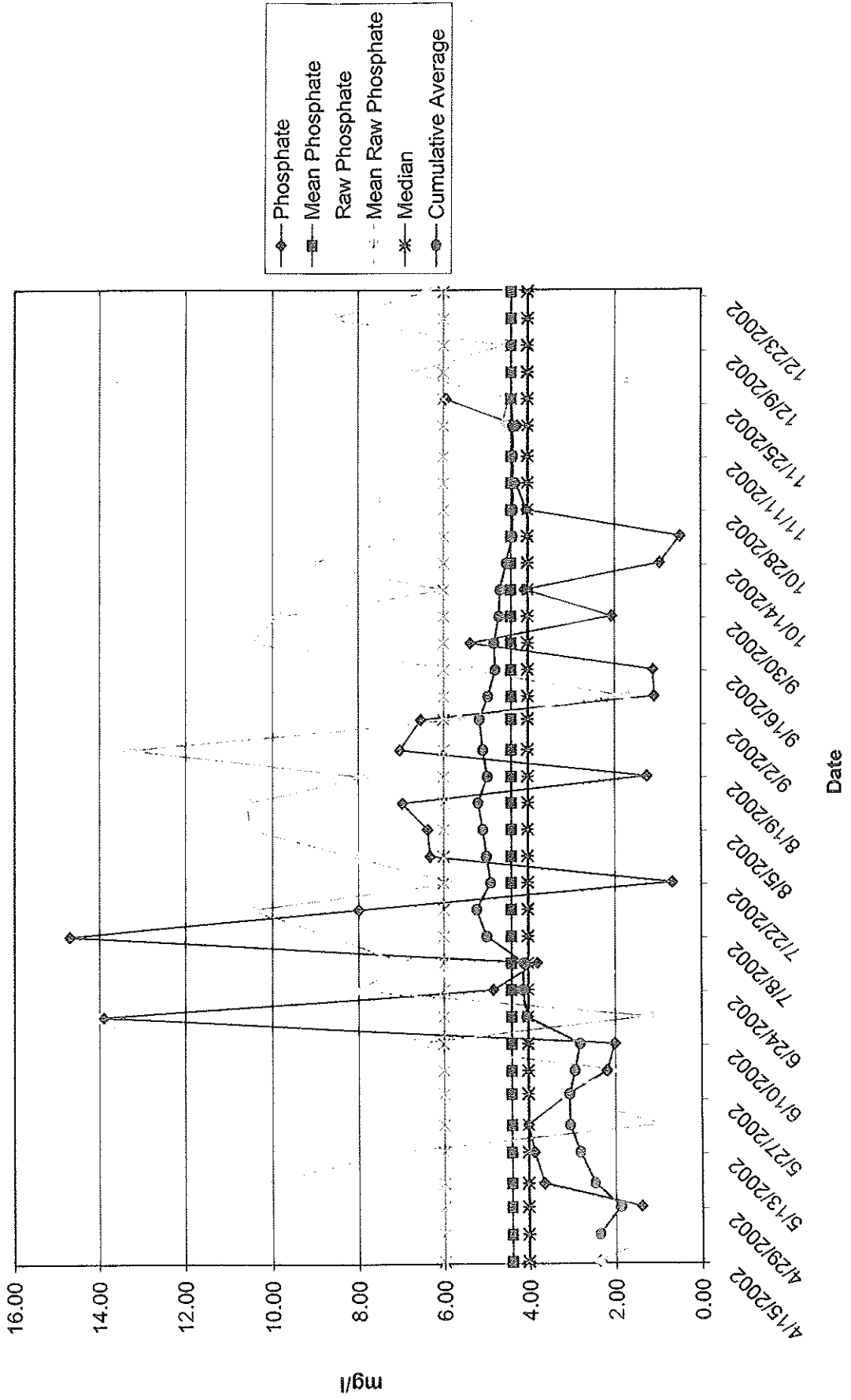



## Appendix II

### Tabular data

The data in these tables are the reported values from the laboratory results. The numbers in the text portion of this report have been modified to take into account appropriate significant figures for averages and calculations and therefore may vary slightly from the numbers in the tables. Percent reductions reported in the text are usually rounded to the nearest whole number when referring to percentage (the second decimal point in the fraction before converting to a percentage). Due to the number of samples and the sampling frequency, the percentages should be considered a guide for planning or evaluating purposes.



DATE	Fecal colonies/100 ml	Mean colonies/100 ml	Median colonies/100 ml	Cumulative Average colonies/100 ml
4/29/2002	10.00	12773.71	2700.00	
5/5/2002	460.00	12773.71	2700.00	235.00
5/13/2002	140.00	12773.71	2700.00	203.33
5/20/2002	10.00	12773.71	2700.00	155.00
5/28/2002	3500.00	12773.71	2700.00	824.00
6/3/2002	5200.00	12773.71	2700.00	1553.33
6/10/2002	50.00	12773.71	2700.00	1338.57
6/17/2002	2700.00	12773.71	2700.00	1508.75
6/24/2002	12000.00	12773.71	2700.00	2674.44
7/1/2002		12773.71	2700.00	2674.44
7/8/2002	96000.00	12773.71	2700.00	12007.00
7/15/2002	50000.00	12773.71	2700.00	15460.91
7/22/2002	39000.00	12773.71	2700.00	17422.50
7/29/2002		12773.71	2700.00	17422.50
8/5/2002	8070.00	12773.71	2700.00	16703.08
8/12/2002	29000.00	12773.71	2700.00	17581.43
8/19/2002	5400.00	12773.71	2700.00	16769.33
8/26/2002	1240.00	12773.71	2700.00	15798.75
9/3/2002	6300.00	12773.71	2700.00	15240.00
9/9/2002	1290.00	12773.71	2700.00	14465.00
9/16/2002	30.00	12773.71	2700.00	13705.26
9/23/2002	200.00	12773.71	2700.00	13030.00
9/30/2002	7000.00	12773.71	2700.00	12742.86
10/7/2002		12773.71	2700.00	12742.86
10/14/2002	16000.00	12773.71	2700.00	12890.91
10/21/2002	135.00	12773.71	2700.00	12336.30
10/28/2002	19000.00	12773.71	2700.00	12613.96
11/4/2002	50.00	12773.71	2700.00	12111.40
11/11/2002		12773.71	2700.00	12111.40
11/19/2002	48000.00	12773.71	2700.00	13491.73
11/26/2002	40000.00	12773.71	2700.00	14473.52
12/3/2002	1900.00	12773.71	2700.00	14024.46
12/10/2002	2200.00	12773.71	2700.00	13616.72
12/17/2002	800.00	12773.71	2700.00	13189.50
12/24/2002	300.00	12773.71	2700.00	12773.71



DATE	TKN mg/l	Mean TKN mg/l	Raw TKN mg/l	lean Raw TKN mg/l	Median mg/l	Cumulative Average mg/l
4/15/2002	2.26	12.78	12.70	29.76	7.04	
4/22/2002		12.78	2.18	29.76	7.04	2.26
4/29/2002	1.93	12.78		29.76	7.04	2.10
5/5/2002	1.30	12.78	26.00	29.76	7.04	1.83
5/13/2002	1.19	12.78	10.30	29.76	7.04	1.67
5/20/2002	1.70	12.78	3.89	29.76	7.04	1.68
5/28/2002	0.57	12.78	4.54	29.76	7.04	1.49
6/3/2002	0.99	12.78	11.20	29.76	7.04	1.42
6/10/2002	1.34	12.78	29.90	29.76	7.04	1.41
6/17/2002	49.80	12.78	13.30	29.76	7.04	6.79
6/24/2002	10.50	12.78	47.10	29.76	7.04	7.16
7/1/2002		12.78	22.30	29.76	7.04	7.16
7/8/2002		12.78	12.60	29.76	7.04	7.16
7/15/2002	23.20	12.78	32.40	29.76	7.04	8.62
7/22/2002	23.00	12.78	16.20	29.76	7.04	9.82
7/29/2002	24.40	12.78	21.60	29.76	7.04	10.94
8/5/2002	23.10	12.78	39.10	29.76	7.04	11.81
8/12/2002	23.20	12.78	45.20	29.76	7.04	12.57
8/19/2002	16.20	12.78	35.40	29.76	7.04	12.79
8/26/2002	35.90	12.78	64.60	29.76	7.04	14.15
9/3/2002	30.80	12.78	31.20	29.76	7.04	15.08
9/9/2002	7.04	12.78	14.30	29.76	7.04	14.65
9/16/2002	1.40	12.78	28.60	29.76	7.04	13.99
9/23/2002	16.60	12.78	44.40	29.76	7.04	14.12
9/30/2002	19.70	12.78	53.00	29.76	7.04	14.37
10/7/2002	24.00	12.78	36.90	29.76	7.04	14.79
10/14/2002	8.68	12.78	40.10	29.76	7.04	14.53
10/21/2002	2.76	12.78	40.80	29.76	7.04	14.06
10/28/2002	6.73	12.78	36.00	29.76	7.04	13.78
11/4/2002	2.41	12.78	36.80	29.76	7.04	13.36
11/11/2002		12.78		29.76	7.04	13.36
11/19/2002	4.64	12.78	18.90	29.76	7.04	13.05
11/26/2002	5.21	12.78	23.00	29.76	7.04	12.78
12/3/2002		12.78	39.00	29.76	7.04	12.78
12/10/2002		12.78	32.50	29.76	7.04	12.78
12/17/2002		12.78	35.10	29.76	7.04	12.78
12/24/2002		12.78	35.10	29.76	7.04	12.78



DATE	Ammonia mg/l	Mean Ammonia mg/l	Raw Ammonia mg/l	Mean Raw Ammonia mg/l	Median mg/l	Cumulative Average mg/l
4/15/2002	0.05	8.79	3.87	16.6	4.18	
4/22/2002		8.79	0.05	16.6	4.18	0.05
4/29/2002	0.22	8.79		16.6	4.18	0.14
5/5/2002	0.05	8.79	27.90	16.6	4.18	0.11
5/13/2002	0.05	8.79	4.97	16.6	4.18	0.09
5/20/2002	0.05	8.79	1.27	16.6	4.18	0.08
5/28/2002	0.05	8.79	3.00	16.6	4.18	0.08
6/3/2002	0.05	8.79	8.02	16.6	4.18	0.07
6/10/2002	0.05	8.79	25.50	16.6	4.18	0.07
6/17/2002	1.64	8.79	4.10	16.6	4.18	0.25
6/24/2002	1.57	8.79	23.70	16.6	4.18	0.38
7/1/2002	15.90	8.79	16.30	16.6	4.18	1.79
7/8/2002	18.40	8.79	18.60	16.6	4.18	3.17
7/15/2002	17.90	8.79	20.20	16.6	4.18	4.31
7/22/2002	19.50	8.79	21.10	16.6	4.18	5.39
7/29/2002	19.10	8.79	22.90	16.6	4.18	6.31
8/5/2002	21.90	8.79	25.20	16.6	4.18	7.28
8/12/2002	21.40	8.79	26.00	16.6	4.18	8.11
8/19/2002	15.30	8.79	30.20	16.6	4.18	8.51
8/26/2002	33.90	8.79	31.80	16.6	4.18	9.85
9/3/2002	23.00	8.79	23.20	16.6	4.18	10.50
9/9/2002	4.35	8.79	6.73	16.6	4.18	10.21
9/16/2002	0.05	8.79	14.60	16.6	4.18	9.75
9/23/2002	10.60	8.79	18.40	16.6	4.18	9.79
9/30/2002	14.20	8.79	63.50	16.6	4.18	9.97
10/7/2002	18.90	8.79	19.00	16.6	4.18	10.33
10/14/2002	5.38	8.79	32.90	16.6	4.18	10.14
10/21/2002	0.66	8.79	7.25	16.6	4.18	9.79
10/28/2002	1.49	8.79	10.30	16.6	4.18	9.49
11/4/2002	0.54	8.79	8.03	16.6	4.18	9.18
11/11/2002		8.79		16.6	4.18	9.18
11/19/2002	1.93	8.79	11.70	16.6	4.18	8.94
11/26/2002	4.18	8.79	12.80	16.6	4.18	8.79
12/3/2002		8.79	26.10	16.6	4.18	8.79
12/10/2002		8.79	21.10	16.6	4.18	8.79
12/17/2002		8.79	20.60	16.6	4.18	8.79
12/24/2002		8.79	18.10	16.6	4.18	8.79



DATE	Nitrate mg/l	Mean Nitrate mg/l	Raw Nitrate mg/l	Mean Raw Nitrate mg/l	Median mg/l	Cumulative Average mg/l
4/15/2002	9.59	6.13	31.50	1.87	4.53	
4/22/2002		6.13	4.89	1.87	4.53	9.59
4/29/2002	6.83	6.13		1.87	4.53	8.21
5/5/2002	20.20	6.13	1.17	1.87	4.53	12.21
5/13/2002	4.53	6.13	0.88	1.87	4.53	10.29
5/20/2002	16.20	6.13	8.51	1.87	4.53	11.47
5/28/2002	10.80	6.13	5.97	1.87	4.53	11.36
6/3/2002	9.33	6.13	0.06	1.87	4.53	11.07
6/10/2002	11.90	6.13	0.05	1.87	4.53	11.17
6/17/2002	2.13	6.13	2.68	1.87	4.53	10.17
6/24/2002	7.76	6.13	0.05	1.87	4.53	9.93
7/1/2002	0.97	6.13	0.05	1.87	4.53	9.11
7/8/2002	0.05	6.13	0.09	1.87	4.53	8.36
7/15/2002	0.05	6.13	0.05	1.87	4.53	7.72
7/22/2002	0.05	6.13	0.05	1.87	4.53	7.17
7/29/2002	0.23	6.13	0.05	1.87	4.53	6.71
8/5/2002	0.42	6.13	0.17	1.87	4.53	6.32
8/12/2002	0.25	6.13	0.05	1.87	4.53	5.96
8/19/2002	2.56	6.13	2.95	1.87	4.53	5.77
8/26/2002	0.05	6.13	0.05	1.87	4.53	5.47
9/3/2002	0.05	6.13	0.05	1.87	4.53	5.20
9/9/2002	5.25	6.13	0.42	1.87	4.53	5.20
9/16/2002	7.04	6.13	0.49	1.87	4.53	5.28
9/23/2002	0.58	6.13	0.05	1.87	4.53	5.08
9/30/2002	0.05	6.13	0.05	1.87	4.53	4.87
10/7/2002	3.10	6.13	0.37	1.87	4.53	4.80
10/14/2002	2.02	6.13	0.31	1.87	4.53	4.69
10/21/2002	17.80	6.13	2.46	1.87	4.53	5.18
10/28/2002	18.30	6.13	0.64	1.87	4.53	5.65
11/4/2002	12.00	6.13	0.90	1.87	4.53	5.87
11/11/2002		6.13		1.87	4.53	5.87
11/19/2002	11.70	6.13	2.86	1.87	4.53	6.06
11/26/2002	8.21	6.13	0.98	1.87	4.53	6.13
12/3/2002		6.13	2.62	1.87	4.53	6.13
12/10/2002		6.13	0.19	1.87	4.53	6.13
12/17/2002		6.13	0.85	1.87	4.53	6.13
12/24/2002		6.13		1.87	4.53	6.13

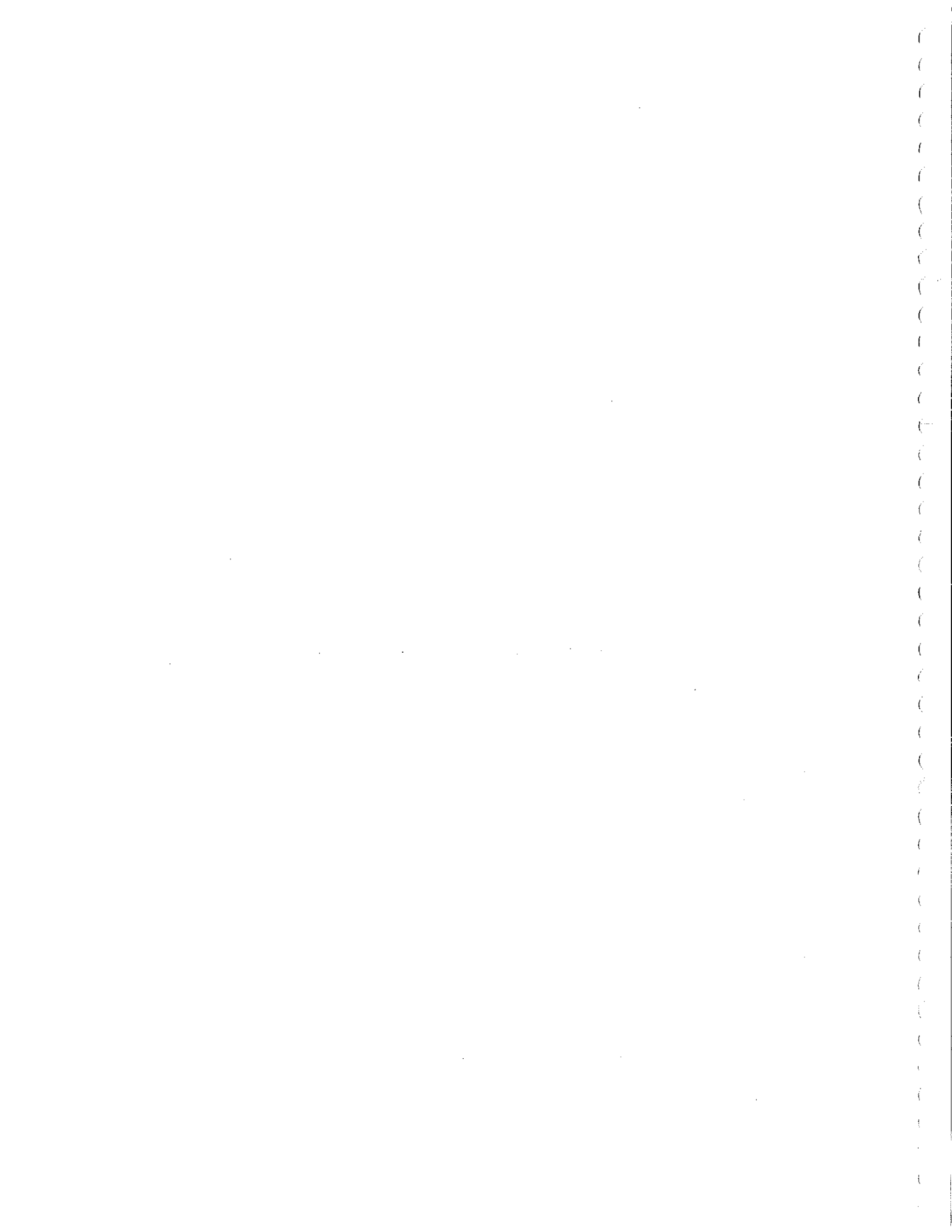

DATE	Nitrite mg/l	Mean Nitrite mg/l	Raw Nitrite mg/l	Mean Raw Nitrite mg/l	Median mg/l	Cumulative Average mg/l
4/15/2002	0.05	0.26	0.85	0.29	0.10	
4/22/2002		0.26	0.16	0.29	0.10	0.05
4/29/2002	1.19	0.26		0.29	0.10	0.62
5/5/2002	0.25	0.26	0.07	0.29	0.10	0.50
5/13/2002	0.19	0.26	0.40	0.29	0.10	0.42
5/20/2002	0.10	0.26	0.34	0.29	0.10	0.36
5/28/2002	0.15	0.26	1.00	0.29	0.10	0.32
6/3/2002	0.05	0.26	0.05	0.29	0.10	0.28
6/10/2002	0.11	0.26	0.05	0.29	0.10	0.26
6/17/2002	0.22	0.26	0.47	0.29	0.10	0.26
6/24/2002	0.40	0.26	0.05	0.29	0.10	0.27
7/1/2002	0.40	0.26	0.05	0.29	0.10	0.28
7/8/2002	0.05	0.26	0.05	0.29	0.10	0.26
7/15/2002	0.05	0.26	0.05	0.29	0.10	0.25
7/22/2002	0.10	0.26	0.05	0.29	0.10	0.24
7/29/2002	0.05	0.26	0.05	0.29	0.10	0.22
8/5/2002	0.05	0.26	0.05	0.29	0.10	0.21
8/12/2002	0.05	0.26	0.05	0.29	0.10	0.20
8/19/2002	0.12	0.26	0.05	0.29	0.10	0.20
8/26/2002	0.05	0.26	0.05	0.29	0.10	0.19
9/3/2002	0.05	0.26	0.05	0.29	0.10	0.18
9/9/2002	0.05	0.26	0.16	0.29	0.10	0.18
9/16/2002	0.05	0.26	0.05	0.29	0.10	0.17
9/23/2002	0.05	0.26	0.05	0.29	0.10	0.17
9/30/2002	0.05	0.26	0.05	0.29	0.10	0.16
10/7/2002	0.05	0.26	0.24	0.29	0.10	0.16
10/14/2002	2.77	0.26	0.05	0.29	0.10	0.26
10/21/2002	0.27	0.26	0.18	0.29	0.10	0.26
10/28/2002	0.10	0.26	0.05	0.29	0.10	0.25
11/4/2002	0.50	0.26	0.24	0.29	0.10	0.26
11/11/2002		0.26		0.29	0.10	0.26
11/19/2002	0.05	0.26	0.15	0.29	0.10	0.25
11/26/2002	0.41	0.26	0.43	0.29	0.10	0.26
12/3/2002		0.26	0.32	0.29	0.10	0.26
12/10/2002		0.26	0.27	0.29	0.10	0.26
12/17/2002		0.26	0.13	0.29	0.10	0.26
12/24/2002		0.26		0.29	0.10	0.26



DATE	Phosphorous mg/l	Mean Phosphorous mg/l	Raw Phosphorous mg/l	Mean Raw Phosphorous mg/l	Median mg/l	Cumulative Average mg/l
4/15/2002	2.72	6.69	2.05	8.20	4.51	
4/22/2002		6.69	1.16	8.20	4.51	2.72
4/29/2002	1.40	6.69		8.20	4.51	2.06
5/5/2002	3.91	6.69	6.40	8.20	4.51	2.68
5/13/2002	3.52	6.69	7.98	8.20	4.51	2.89
5/20/2002	4.49	6.69	1.33	8.20	4.51	3.21
5/28/2002	3.34	6.69	2.70	8.20	4.51	3.23
6/3/2002	2.37	6.69	2.57	8.20	4.51	3.11
6/10/2002	1.92	6.69	8.19	8.20	4.51	2.96
6/17/2002	56.10	6.69	2.57	8.20	4.51	8.86
6/24/2002	6.54	6.69	11.20	8.20	4.51	8.63
7/1/2002	4.40	6.69	8.62	8.20	4.51	8.25
7/8/2002	23.80	6.69	10.70	8.20	4.51	9.54
7/15/2002	7.82	6.69	5.03	8.20	4.51	9.41
7/22/2002	6.88	6.69	6.70	8.20	4.51	9.23
7/29/2002	5.72	6.69	9.18	8.20	4.51	9.00
8/5/2002	6.96	6.69	13.40	8.20	4.51	8.87
8/12/2002	6.58	6.69	13.30	8.20	4.51	8.73
8/19/2002	2.06	6.69	9.73	8.20	4.51	8.36
8/26/2002	8.70	6.69	18.20	8.20	4.51	8.38
9/3/2002	7.65	6.69	5.49	8.20	4.51	8.34
9/9/2002	2.00	6.69	2.34	8.20	4.51	8.04
9/16/2002	1.20	6.69	8.48	8.20	4.51	7.73
9/23/2002	5.11	6.69	10.10	8.20	4.51	7.62
9/30/2002	2.78	6.69	12.50	8.20	4.51	7.42
10/7/2002	4.51	6.69	8.36	8.20	4.51	7.30
10/14/2002	1.26	6.69	18.30	8.20	4.51	7.07
10/21/2002	0.79	6.69	9.57	8.20	4.51	6.83
10/28/2002	6.06	6.69	11.70	8.20	4.51	6.81
11/4/2002	5.44	6.69	10.50	8.20	4.51	6.76
11/11/2002		6.69		8.20	4.51	6.76
11/19/2002	4.59	6.69	5.88	8.20	4.51	6.69
11/26/2002	6.72	6.69	6.10	8.20	4.51	6.69
12/3/2002		6.69	7.26	8.20	4.51	6.69
12/10/2002		6.69	7.26	8.20	4.51	6.69
12/17/2002		6.69	12.10	8.20	4.51	6.69
12/24/2002		6.69	10.40	8.20	4.51	6.69



**Performance Testing and Evaluation Certification Report**

Baylor University  
Department of Environmental Studies  
Individual On-Site Waste Water Treatment System  
Testing and Certification Program  
on the

**Aqua Aire 500**  
**With Model Series 600, 750, 1000, and 1500**

Manufactured by Ecological Tanks, Inc.  
Downsville, Louisiana, U.S.A.

**Original Report: May 2, 2002**

DATE	Nitrite mg/l	Mean Nitrite mg/l	Raw Nitrite mg/l	Mean Raw Nitrite mg/l	Median mg/l	Cumulative Average mg/l
4/15/2002	0.05	0.26	0.85	0.29	0.10	
4/22/2002		0.26	0.16	0.29	0.10	0.05
4/29/2002	1.19	0.26		0.29	0.10	0.62
5/5/2002	0.25	0.26	0.07	0.29	0.10	0.50
5/13/2002	0.19	0.26	0.40	0.29	0.10	0.42
5/20/2002	0.10	0.26	0.34	0.29	0.10	0.36
5/28/2002	0.15	0.26	1.00	0.29	0.10	0.32
6/3/2002	0.05	0.26	0.05	0.29	0.10	0.28
6/10/2002	0.11	0.26	0.05	0.29	0.10	0.26
6/17/2002	0.22	0.26	0.47	0.29	0.10	0.26
6/24/2002	0.40	0.26	0.05	0.29	0.10	0.27
7/1/2002	0.40	0.26	0.05	0.29	0.10	0.28
7/8/2002	0.05	0.26	0.05	0.29	0.10	0.26
7/15/2002	0.05	0.26	0.05	0.29	0.10	0.25
7/22/2002	0.10	0.26	0.05	0.29	0.10	0.24
7/29/2002	0.05	0.26	0.05	0.29	0.10	0.22
8/5/2002	0.05	0.26	0.05	0.29	0.10	0.21
8/12/2002	0.05	0.26	0.05	0.29	0.10	0.20
8/19/2002	0.12	0.26	0.05	0.29	0.10	0.20
8/26/2002	0.05	0.26	0.05	0.29	0.10	0.19
9/3/2002	0.05	0.26	0.05	0.29	0.10	0.18
9/9/2002	0.05	0.26	0.16	0.29	0.10	0.18
9/16/2002	0.05	0.26	0.05	0.29	0.10	0.17
9/23/2002	0.05	0.26	0.05	0.29	0.10	0.17
9/30/2002	0.05	0.26	0.05	0.29	0.10	0.16
10/7/2002	0.05	0.26	0.24	0.29	0.10	0.16
10/14/2002	2.77	0.26	0.05	0.29	0.10	0.26
10/21/2002	0.27	0.26	0.18	0.29	0.10	0.26
10/28/2002	0.10	0.26	0.05	0.29	0.10	0.25
11/4/2002	0.50	0.26	0.24	0.29	0.10	0.26
11/11/2002		0.26		0.29	0.10	0.26
11/19/2002	0.05	0.26	0.15	0.29	0.10	0.25
11/26/2002	0.41	0.26	0.43	0.29	0.10	0.26
12/3/2002		0.26	0.32	0.29	0.10	0.26
12/10/2002		0.26	0.27	0.29	0.10	0.26
12/17/2002		0.26	0.13	0.29	0.10	0.26
12/24/2002		0.26		0.29	0.10	0.26

100-100000

DATE	Phosphate mg/l	Mean Phosphate mg/l	Raw Phosphate mg/l	Mean Raw Phosphate mg/l	Median mg/l	Cumulative Average mg/l
4/15/2002	2.37	4.41	2.40	6.00	4.03	
4/22/2002		4.41	0.93	6.00	4.03	2.37
4/29/2002	1.40	4.41		6.00	4.03	1.89
5/5/2002	3.66	4.41	10.30	6.00	4.03	2.48
5/13/2002	3.88	4.41	7.19	6.00	4.03	2.83
5/20/2002	4.03	4.41	0.94	6.00	4.03	3.07
5/28/2002	3.10	4.41	3.35	6.00	4.03	3.07
6/3/2002	2.19	4.41	1.92	6.00	4.03	2.95
6/10/2002	2.01	4.41	6.79	6.00	4.03	2.83
6/17/2002	13.90	4.41	1.23	6.00	4.03	4.06
6/24/2002	4.84	4.41	8.02	6.00	4.03	4.14
7/1/2002	3.81	4.41	6.89	6.00	4.03	4.11
7/8/2002	14.70	4.41	8.63	6.00	4.03	4.99
7/15/2002	7.99	4.41	10.50	6.00	4.03	5.22
7/22/2002	0.67	4.41	5.78	6.00	4.03	4.90
7/29/2002	6.32	4.41	8.14	6.00	4.03	4.99
8/5/2002	6.37	4.41	10.50	6.00	4.03	5.08
8/12/2002	6.96	4.41	10.60	6.00	4.03	5.19
8/19/2002	1.26	4.41	7.88	6.00	4.03	4.97
8/26/2002	7.02	4.41	13.30	6.00	4.03	5.08
9/3/2002	6.53	4.41	5.71	6.00	4.03	5.15
9/9/2002	1.09	4.41	1.78	6.00	4.03	4.96
9/16/2002	1.12	4.41	5.44	6.00	4.03	4.78
9/23/2002	5.37	4.41	10.50	6.00	4.03	4.81
9/30/2002	2.07	4.41	9.91	6.00	4.03	4.69
10/7/2002	4.10	4.41	5.98	6.00	4.03	4.67
10/14/2002	0.96	4.41	9.12	6.00	4.03	4.53
10/21/2002	0.48	4.41	6.96	6.00	4.03	4.38
10/28/2002	4.05	4.41	7.50	6.00	4.03	4.37
11/4/2002	4.29	4.41	7.50	6.00	4.03	4.36
11/11/2002		4.41		6.00	4.03	4.36
11/19/2002	4.26	4.41	4.63	6.00	4.03	4.36
11/26/2002	5.94	4.41	4.46	6.00	4.03	4.41
12/3/2002		4.41	6.76	6.00	4.03	4.41
12/10/2002		4.41	4.58	6.00	4.03	4.41
12/17/2002		4.41	8.64	6.00	4.03	4.41
12/24/2002		4.41	6.41	6.00	4.03	4.41

