

MODIFICATION

**State of Maine**



**Master Agreement**

**Effective Date:** 06/06/17

**Expiration Date:** 06/05/19

**Master Agreement Description:** Platform Rack Body-9'

**Buyer Information**

Donny Crockett 207-624-7336 ext. Donny.Crockett@maine.gov

**Issuer Information**

Jessica Norton 207-624-8226 ext. Jessica.h.norton@MAINE.GOV

**Requestor Information**

Jessica Norton 207-624-8226 ext. Jessica.h.norton@MAINE.GOV

**Authorized Departments**

17D MOTOR TRANSPORT

**Vendor Information**

**Vendor Line #:** 1

**Vendor ID**

VS0000000040

**Vendor Name**

Hews Company, LLC

**Alias/DBA**

**Vendor Address Information**

190 Rumery Street

South Portland, ME 04106

US

**Vendor Contact Information**

Katy Hews

207-767-2136 ext. 121

khews@hewSCO.com

**Payment Discount Terms**

**Discount 1:** 1.0000 % 30 Days

**Discount 2:** % 0 Days

**Discount 3:** % 0 Days

**Discount 4:** % 0 Days

## Commodity Information

**Vendor Line #:** 1

**Vendor Name:** Hews Company, LLC

**Commodity Line #:** 1

**Commodity Code:** 06500

**Commodity Description:** Platform Rack Body-9'

**Commodity Specifications:**

**Commodity Extended Description:** As per the specifications attached and made part of this MA

<b>Quantity</b> 0.00000	<b>UOM</b>	<b>Unit Price</b> \$0.00
<b>Delivery Days</b> 60	<b>Free on Board</b>	
<b>Contract Amount</b> \$0.00	<b>Service Start Date</b>	<b>Service End Date</b>
<b>Catalog Name</b> Rack Body	<b>Discount</b> 0.0000 %	
	<b>Discount Start Date</b> 06/06/17	<b>Discount End Date</b> 06/05/19

## Terms and Conditions

### **Agreement Terms and Conditions**

**T&C #:** 165

**T&C Name:** Payment Terms

**T&C Details:** Net 30

Division of Procurement Services  
Burton M Cross Bldg.  
9 State House Station  
Augusta, ME 04333-0009  
Tel. (207) 624-7336  
Fax.# (207) 624-5086

Contract Number  
MA 170606\*145

### EXTENSION OF ANNUAL CONTRACT

**Commodity Item:** Master Agreement for Platform Rack Body

**Contractor:** Hews Company, LLC

**Contract Period Extended To:** 6/5/2019

**Current Pricing:** See Attached Spreadsheet

**New Lower Pricing:** Please Fill In Attached Spreadsheet with Updated Pricing

**Extension Clause:** The State reserves the right to extend this contract for a period of one year, with the consent of the contractor.

**Agreement to Extend Contract:**

In accordance with the above referenced Extension Clause, the undersigned agrees to continue in effect said Contract No # MA 170606\*145 until June 5, 2019 with all terms, conditions remaining as shown in the original contract.

Copy of which is acknowledged on this date.

Contractor:

By: \_\_\_\_\_

Hews Company  
Printed

[Signature]  
Signature

E-mail Address: bhews@hewscsco.com

Date: 10/18/18

Dollar value the State has spent on this contract from 6/6/17 to present: \$ 62,020<sup>-</sup>



**HEWS COMPANY, LLC**  
 190 RUMERY STREET  
 SOUTH PORTLAND ME 04106  
 PHONE: (207) 767-2136  
 FAX: (207) 767-5381

ATTN:DAN ROLFE  
 MAINE DEPT OF TRANS-AUGUSTA  
 STATE HOUSE STATION 26  
 105 CAPITAL STREET  
 AUGUSTA ME 04333-0026

Quote Date: 10/18/18  
 Order #: U73534  
 Sales Rep: DAVE GAIN  
 Customer #: 13246  
 Telephone #: 207-624-3132  
 Fax #: 207-287-8757

- =====
- 1 - 9' STAKE BODY MODEL: H-9-W HEAVY DUTY
  - Length: 9' 5 1/2" Width: 96"
  - Racks: 42" High Steel-Black-Quick release on post.
  - Headboard: 42" Stand alone steel front bulkhead w/braces-welded at front.
  - Window in front bulkhead, 12" reinforced cab shield.
  - Floor: 2x6 ship lap treated dense pine.
  - Cross members 4 1/4" x 11 ga - 13" centers with gussets.
  - Longsills: 6" Structural channel (8.2 lbs per foot) and 114" long, 34" o/c.
  - LED Marker lights, reflectors, loom.
  - Triple protection - A60 Galvanealed steel, E-Coat primer, and Black Powder Coat finish coat.
  - Three-year limited warranty.
  - Flatbed dump hitch plate bumper (1809055), 2" receiver, D-rings, 7 prong round plug. 17,000Lb MGTW Rating
  - Back up Alarm.
  - Body mount kit - U bolts - Oak Frame Strips.
  - ICC bumper, rear flaps, flap brackets, anti-sail, flaps.

INSTALLED, FOB, AUGUSTA, ME \$6,115.00\*

OPTION INCLUDED:

- 1. INSTALL LABOR: BODY, RACKS, HEADBOARD, CAB SHIELD, HITCH, BACK-UP ALARM AND PAINT NEW WORK

PO# MA18P17060600145 - EXTEND TO 6/5/19

\*PRICE RELFECTS PRICE INCREASES BETWEEN JUNE 2017 AND AUGUST 2018 FROM EQUIPMENT AND PARTS SUPPLIERS.

SALESPERSON: BOB HEWS / DAVE GAIN CONTACT: DAN ROLFE (207) 441-2352

=====

VIN:	FLEET ID:
MAKE/MODEL: FORD F550	YEAR: 2019
TRANS: AUTOMATIC	ENGINE: DIESEL/GAS
GVW: 19,500	CA: 60"

**Please sign order and return 1 copy**

TERMS: **1%30NET35**

Sub-Total	6,115.00
F.E.T.	0.00
Sales Tax	0.00

\_\_\_\_\_  
 Signature Date

**Total 6,115.00**

QUOTE VALID FOR 30 DAYS



HEWS COMPANY, LLC  
 190 RUMERY STREET  
 SOUTH PORTLAND ME 04106  
 PHONE: (207) 767-2136  
 FAX: (207) 767-5381

ATTN:DAN ROLFE  
 MAINE DEPT OF TRANS-AUGUSTA  
 STATE HOUSE STATION 26  
 105 CAPITAL STREET  
 AUGUSTA ME 04333-0026

Quote Date: 10/18/18  
 Order #: U73535  
 Sales Rep: DAVE GAIN  
 Customer #: 13246  
 Telephone #: 207-624-3132  
 Fax #: 207-287-8757

=====

- 1 - 9' STAKE BODY MODEL: H-9-W HEAVY DUTY
  - Length: 9' 5 1/2" Width: 96"
  - Racks: 42" High Steel-Black-Quick release on post.
  - Headboard: 42" Stand alone steel front bulkhead w/braces-welded at front.
  - Window in front bulkhead, 12" reinforced cab shield.
  - Floor: 2x6 ship lap treated dense pine.
  - Cross members 4 1/4" x 11 ga - 13" centers with gussets.
  - Longsills: 6" Structural channel (8.2 lbs per foot) and 114" long, 34" o/c.
  - LED Marker lights, reflectors, loom.
  - Triple protection - A60 Galvanealed steel, E-Coat primer, and Black Powder Coat finish coat.
  - Three-year limited warranty.
  - Flatbed dump hitch plate bumper (1809055), 2" receiver, D-rings, 7 prong round plug. 17,000Lb MGTW Rating
  - Back up Alarm.
  - ICC bumper, rear flaps, flap brackets, anti-sail, flaps.

INSTALLED, FOB, AUGUSTA, ME \$6,115.00\*

- 1 - READING CONVERSION HOIST, MODEL RTB813 CLASS B
  - Electric Hydraulic - DA acting powered,
  - Includes body prop, in cab controls.
  - 6.5 Ton capacity at 45 degree.
  - Three-year limited warranty

INSTALLED, FOB, AUGUSTA, ME \$3,375.00\*

\*\*\* CONTINUED NEXT PAGE \*\*\*



**HEWS COMPANY, LLC**  
 190 RUMERY STREET  
 SOUTH PORTLAND ME 04106  
 PHONE: (207) 767-2136  
 FAX: (207) 767-5381

ATTN:DAN ROLFE  
 MAINE DEPT OF TRANS-AUGUSTA  
 STATE HOUSE STATION 26  
 105 CAPITAL STREET  
 AUGUSTA ME 04333-0026

Quote Date: 10/18/18  
 Order #: U73535  
 Sales Rep: DAVE GAIN  
 Customer #: 13246  
 Telephone #: 207-624-3132  
 Fax #: 207-287-8757

- =====
- 1 - EAGLE LIFT MODEL E50-91
    - Capacity: 1600 Lb
    - Platform: 86 x 34 x 4 (38" total) Steel.
    - Quick release sure-hold safety locks.
    - Electric hydraulic pump, built in relief valves.
    - Oil impregnated bronze bushings at all pivot points.
    - 150 amp circuit breaker.
    - Power cut off integrated with vehicle switch. Toggle switch control.
    - Automotive Grade E Coat Black Topcoat paint.
    - Torsion spring assist folding.

INSTALLED, FOB, AUGUSTA, ME \$3,325.00

OPTIONS NOT INCLUDED:

- 1. SWING REAR GATES ON RACK ADD: \$545.00
- 2. PULL-OUT STEP ADD: \$350.00

PO# MA18P17060600145 - EXTEND TO 6/5/2019

\*PRICE REFLECTS PRICE INCREASES BETWEEN JUNE 2017  
 AND AUGUST 2018 FROM EQUIPMENT AND PARTS SUPPLIERS.

SALESPERSON: BOB HEWS / DAVE GAIN DAN ROLFE (207) 441-2352

=====

VIN:		FLEET ID:	
MAKE/MODEL:	FORD F550	YEAR:	2019
TRANS:	AUTOMATIC	ENGINE:	DIESEL/GAS
GVW:	19,500	CA:	60"

**Please sign order  
 and return 1 copy**

TERMS:  
**1%30NET35**

Sub-Total	12,815.00
F.E.T.	0.00
Sales Tax	0.00

<hr/> Signature	<hr/> Date	<b>Total</b>	<hr/> <b>12,815.00</b>
-----------------	------------	--------------	------------------------

QUOTE VALID FOR 30 DAYS

VENDOR CUSTOMER CODE	SUPPLIER PART NUMBER	SUPPLIER NAME	MANUFACTURER NAME	MANUFACTURER PART NUMBER	COMMODITY CODE	ITEM DESCRIPTION	EXTENDED DESCRIPTION	UNIT OF MEASURE	LIST PRICE	DELIVERY DAYS
VS0000000040	H9W	Hews Company			06500	Reading body Bumper Hitch installation Delivery	n/a	EA	\$6,115.00	60
VS0000000040	E50-91	Hews Company			06500	Eagle Lift & installation	n/a	EA	\$3,325.00	60
VS0000000040	RTB813	Hews Company			06500	Conversion Hoist & installation	n/a	EA	\$3,375.00	60
VS0000000040	Swing	Hews Company			06500	Swing Gate System & installation	n/a	EA	\$545.00	60
VS0000000040	TRA3000	Hews Company			06500	Step System Ladder & installation	n/a	EA	\$350.00	60

**STATE OF MAINE  
DEPARTMENT OF ADMINISTRATIVE AND FINANCIAL SERVICES  
BUREAU OF GENERAL SERVICES  
DIVISION OF PURCHASES**

**RFQ # 17D 17040500000000000614**

**PLATFORM RACK BODY**

**Quotations/Responses Due:** 5/05/17 not later than 2:00 p.m. local time

**Note:** All questions and responses must be provided via the State of Maine's e-Procurement system: AdvantageME / Vendor Self Service (VSS).

**General Instructions on Bidder Questions**

It is the responsibility of each Bidder to examine the entire RFQ and to seek clarification by submitting questions through the Q & A List tab on the Solicitation page. Any answers to questions will appear there as well. It is the vendor's responsibility to log in to view all questions and answers posted. Additional information obtained any other way will not be valid.

**In the event that you must contact us for any other reasons than the Q & A previously mentioned**, only the Buyer listed on the Solicitation page may be contacted from the time this RFQ is issued until award notification is made. No other person/State employee is empowered to make binding statements regarding this RFQ. Violation of this provision may lead to disqualification from the bidding process, at the State's discretion.

**Summary**

For this competitive Request for Quotations (RFQ) process, the State of Maine Division of Purchases ("Division") is acting on behalf of MaineDOT Fleet Services ("Requesting Department"). The Division and the Requesting Department seek quotations (also referred to as "bids" or "responses" herein) to provide the goods/services listed above. This document provides instructions and descriptions of requirements for this competitive process.



## RFQ REQUIREMENTS

### 1. Description of Requirements

The following is a description of the goods and/or services sought by the State of Maine under this RFQ.

- Please see Appendix B

### 2. Bid Contents Requirements

In addition to the cost, delivery, and other information required in VSS, all bids should contain the following information as attachments, in the Appendices listed below:

- Appendix A: Bid Cover Page & Debarment form
- Appendix B: Detailed Specifications
- Appendix C: Cost Response
- Appendix D: Municipality Participation
- Appendix E: Certifications
- Appendix F: MaineDOT terms and conditions

3. Master Agreement Term In addition to any mutually agreed upon delivery dates for purchases of goods, the contract resulting from this RFQ will have a term, or “Period of Performance”, during which the contract is considered to be in effect. The anticipated contract term is defined in the table below. Please note that the dates below are estimated and may be adjusted as necessary in order to comply with all procedural requirements associated with this RFQ and the contracting process. The actual contract start date will be established by the completed and approved contract.

Contract Renewal: Following the initial term of the contract, the Division may opt to renew the contract for two renewal periods of one year each, subject to continued availability of funding and satisfactory delivery/performance.

The term of the anticipated contract, resulting from this RFQ, is defined as follows:

<b>Period</b>	<b>Start Date</b>	<b>End Date</b>
Initial Period of Performance	5/15/17	5/14/18
Renewal Period #1	5/15/18	5/14/19
Renewal Period #2	5/15/19	5/14/20

#### 4. **Submitting a Quotation**

- a. **Quotations Due:** Quotations must be received no later than 2:00 p.m. Eastern Standard Time (EST), on the date listed in VSS. Quotations received after the 2:00 p.m. deadline will not be accepted.
- b. **Submission Instructions:** Bidders must submit their bids in the State of Maine's electronic procurement system: Advantage "Vendor Self Service" (VSS). More information on this system can be found at the following internet link:  
<http://www.maine.gov/purchases/venbid/rfq.shtml>.
- c. **Multiple Quotations:** Unless specifically prohibited in Section 1 of this RFQ, Bidders are permitted to submit multiple quotations for this RFQ, offering alternative items or pricing for the State of Maine to consider in its best value determination.
- d. **Withdrawal of a Quotation:** Bidders are permitted to withdraw their own quotations up until the due date and time for receipt of quotations. To do so, a Bidder must enter the VSS system (as referenced above), identify and open their submitted quotation located in the Solicitation Responses tab, and click the "Withdraw" button found at the bottom of the screen. Quotations cannot be withdrawn after the due date and time for receipt of quotations.
- e. **Attachments:** Any attachments provided with the Advantage VSS bid submission must be in MS Word, MS Excel, or Adobe (.pdf) format, unless otherwise specified in Section 1 of this RFQ. Vendors are encouraged to submit supporting documentation that aid the requesting department in understanding how the bid conforms to the requirements. **The VSS attachment file size limit is 2Mb.** Please contact the buyer for this RFQ if you must submit attachment files larger than this.
- f. **Vendor specifications:** Unless otherwise stated in this RFQ document, limited specification information will be required upon submission of a bid in response to this RFQ. However, a Bidder's response should include an affirmative statement that their bid complies with all requirements of this RFQ, unless the Bidder specifically addresses how its bid differs from the specifications, and why the differences should be deemed acceptable by the State.

#### 5. **General Instructions**

- a. The Bidder must submit a cost quotation response that covers the goods and term of the contract, including any optional renewal.
- b. The cost quotation shall include the costs necessary for the Bidder to fully comply with the contract terms and conditions and RFQ requirements.
- c. Failure to provide the requested information may result in the exclusion of the quotation from consideration, at the discretion of the Division.

- d. No costs related to the preparation of the quotation for this RFQ or to the negotiation of the contract with the Department may be included in the quotation.
- e. The State is exempt from the payment of Federal, State and local Taxes on articles not for resale. Please provide quotations that do not include these taxes. Upon application, an exemption certificate can be furnished by the State at the point of contract finalization.

## 6. QUOTATION EVALUATION AND SELECTION

Evaluation of the submitted quotations shall be accomplished as detailed below:

- a. State of Maine RFQ documents are evaluated on a **Best Value** basis. The term “Best Value” takes into consideration the qualities of the goods or services to be supplied, their conformity with the specifications listed in the RFQ, the purposes for which they are required, the date of delivery, and the best interest of the State. Once the goods or services have been determined to conform to the specifications listed, and other Best Value considerations have been made, then the Division will make its award decision based on the lowest price among the Bidders.
- b. At the discretion of the Division, if a Bidder’s submission is deemed to not conform to the specifications listed in the RFQ, or otherwise not conform to the requirements of the RFQ, then that Bidder’s submission may not be considered for contract award.
- c. In the event that no Bidder submission conforms to the specifications of this RFQ, then the Division may choose not to make any award. Alternatively, the Division may make an award to the Best Value Bidder whose specifications *most closely meet* the specifications of this RFQ. For example, if there are five specification requirements, and two responses are received with one Bidder meeting four requirements, and one bidder meeting three requirements, then the Division, at its discretion, may make a contract award to the Bidder meeting four requirements.
- d. If the specifications provided with this RFQ are of a technical nature, then the Division’s RFQ Coordinator, at his or her discretion, may seek to use an evaluation team comprised of subject matter experts, end-users from the Requesting Department, or other State Department representatives. In such a case, the evaluation team will judge the merits of the quotations received in accordance with the criteria defined in the RFQ.

## 7. Negotiations

- a. No Best and Final Offers: The State of Maine will not seek a best and final offer (BAFO) from any Bidder in this procurement process. All Bidders are expected to provide their Best Value pricing with the submission of their quotation.

- b. The Division reserves the right to negotiate with the successful Bidder to finalize a contract at the same rate or cost of goods and services as presented in the selected quotation. Such negotiations may not significantly vary the content, nature or requirements of the quotation or the RFQ to an extent that may affect the price of goods or services requested. The Division reserves the right to terminate contract negotiations with a selected Bidder who submits a proposed contract significantly different from the quotation submitted in response to the RFQ.
  
- c. In the event that an acceptable contract cannot be negotiated with the highest ranked Bidder, the Division may withdraw its award and negotiate with the next-highest ranked Bidder, and so on, until an acceptable contract has been finalized. Alternatively, the Division may cancel the RFQ, at its sole discretion.

# TERMS AND CONDITIONS FOR RFQ AND CONTRACT

## **PART I GENERAL INFORMATION ON RFQs**

### **A. Purpose and Background**

The State of Maine (“State”) Department of Administrative and Financial Services (“Department”), Bureau of General Services (“Bureau”), Division of Purchases (“Division”) acts as the purchasing agent on behalf of all Executive Departments and other agencies within State Government. For this competitive Request for Quotations (RFQ) process, the Division is acting on behalf of the Requesting Department listed on the cover page. The Division and the Requesting Department seek quotations (also referred to as “bids” or “responses” herein) to provide the goods/services as defined above in Section 1 of this document. This document provides instructions for submitting quotations, the procedure and criteria by which the Bidder(s) will be selected, and the contractual terms which will govern the relationship between the State and the awarded Bidder(s). Following Bidder selection and upon reaching a mutual agreement, the State and the selected Bidder will enter into a contract – taking the form of a State of Maine Master Agreement or Buyer Purchase Order (all generally referred to as “contract” herein), as applicable.

### **B. General Provisions**

1. Issuance of this RFQ does not commit the Division or the Requesting Department to issue an award or to pay expenses incurred by a Bidder in the preparation of a response to this RFQ. This includes attendance at personal interviews or other meetings and software or system demonstrations, where applicable.
2. All responses to this RFQ should adhere to the instructions and format requirements outlined in this RFQ and all written supplements and amendments (such as the Division’s answers to the Bidders’ questions submitted through the VSS), as issued by the Division. Responses are to follow the format and respond to all questions and instructions specified above in the “Submitting a Quotation” section of this RFQ.
3. Bidders shall take careful note that in evaluating a quotation submitted in response to this RFQ, the Department may consider materials provided in the quotation, information obtained through interviews/presentations (if any), and internal information of previous contract history between the Division and the Bidder (if any). The Division also reserves the right to consider other reliable references and publicly available information available in evaluating a Bidder’s experience and capabilities, if needed. All responses to this RFQ shall be considered to be authorized to legally bind the Bidder, and if selected for award, shall contain or be considered to contain a statement that the quotation and the pricing contained therein will remain valid and binding for a period of at least 180 days from the date and time of the bid opening.
4. The RFQ and the selected Bidder’s quotation, including all appendices or attachments, may be incorporated in the final contract.
5. Following announcement of an award decision, all submissions in response to this RFQ will be considered public records available for public inspection pursuant to the State of Maine Freedom of Access Act (FOAA) (1 M.R.S. §§ 401 et seq.).
6. The Division, at its sole discretion, reserves the right to recognize and waive minor informalities and irregularities found in quotations received in response to this RFQ.

7. The Division reserves the right to authorize other State Departments to use the contract(s) resulting from this RFQ, if it is deemed to be beneficial for the State to do so.
8. All applicable laws, whether or not herein contained, shall be included by this reference. It shall be Bidder's responsibility to determine the applicability and requirements of any such laws and to abide by them.

**C. Eligibility to Submit Bids**

Public agencies, private for-profit companies, and non-profit companies and institutions are invited to submit bids in response to State of Maine Requests for Quotations.

**D. Delivery Terms**

For the purchase of goods, the Division and selected Bidder will decide upon a delivery date in accordance with the State's requirements and the terms offered in the Bidder's quotation. Unless stated otherwise in Section 1 of this RFQ, all deliveries are expected with shipping terms of "Free on Board (FOB) – Destination". The State intends for this to mean that all goods shall be priced in the bid response to include shipping charges, if any, to the State's desired location. The "FOB – Destination" shipping term is also intended to mean that the State shall not bear any responsibility for the goods in question until the State takes possession of them at the destination point of delivery.

**E. Alternate Bids and Approved Equals**

When, in bid forms and specifications, an article or material is identified by using a trade name and catalog number of a manufacturer or vendor, the term "or approved equal," if not inserted with the identification, is implied. Any Bidder that seeks to propose an alternate item from what is specified in this RFQ should refer to State of Maine Statute 5 MRSA §1825-B, for "Bids, awards and contracts", found here: <http://www.mainelegislature.org/legis/statutes/5/title5sec1825-B.html>

**F. Appeal of Contract Awards**

Any person aggrieved by the award decision that results from this RFQ may appeal the decision to the Director of the Bureau of General Services in the manner prescribed in 5 MRSA § 1825-E and 18-554 Code of Maine Rules, Chapter 120 (found here: <http://www.maine.gov/purchases/policies/120.shtml>). The appeal must be in writing and filed with the Director of the Bureau of General Services, 9 State House Station, Augusta, Maine, 04333-0009 within 15 calendar days of receipt of notification of contract award.

If this RFQ results in the creation of a pre-qualified or pre-approved list of vendors, then the appeal procedures mentioned above are available upon the original determination of that vendor list, but not during subsequent competitive procedures involving only the pre-qualified or pre-approved list participants.

## **PART II CONTRACT ADMINISTRATION AND CONDITIONS**

### **A. Contract Document**

The successful Bidder will be required to execute a contract in the form of a State of Maine Buyer Purchase Order, Contract Agreement to Purchase Services or State of Maine Master Agreement.

The Standard Terms and Conditions used with the aforementioned contract types may be found on the Division of Purchases website at the following link:

[http://www.maine.gov/purchases/info/forms/BPO\\_General\\_Terms.doc](http://www.maine.gov/purchases/info/forms/BPO_General_Terms.doc)

In the event that the State of Maine's Standard Terms and Conditions or RFQ provisions do not otherwise cover contractual scenarios that are specific to the goods or services being purchased under this RFQ, then the State is willing to consider a Bidder's standard terms and conditions. Consideration or use of a Bidder's standard terms and conditions shall only occur under the general agreement that in the event of a conflict, the State of Maine's Standard Terms and Conditions and RFQ provisions shall take precedence.

Other forms and contract documents commonly used by the State can be found on the Division of Purchases website at the following link: <http://www.maine.gov/purchases/info/forms.shtml>

### **B. Independent Capacity**

In providing services and performing under the contract, the successful Bidder shall act independently and not as an agent of the State of Maine.

### **C. Payments and Other Provisions**

The State anticipates paying the selected Bidder for goods and services received, on the basis of net 30 payment terms, upon the receipt of an accurate and acceptable invoice. An invoice will be considered accurate and acceptable if it contains a reference to the State of Maine contract number, contains correct pricing information relative to the contract, and provides any required supporting documents, as applicable, and any other specific and agreed-upon requirements listed within the contract that results from this RFQ.

The State of Maine reserves the right to pay for goods purchased through this solicitation by any of several available means, which include but may not be limited to check, EFT, and/or procurement card. Bidders are advised that state statute precludes sellers from imposing a surcharge on credit or debit card purchases (text follows):

“9-A MRSA §8-303 (2): A seller in a sales transaction may not impose a surcharge on a cardholder who elects to use a credit card or debit card in lieu of payment by cash, check or similar means.”

Appendix A

**STATE OF MAINE  
DEPARTMENT OF ADMINISTRATIVE AND FINANCIAL SERVICES  
DIVISION OF PURCHASES**

**BID COVER PAGE and DEBARMENT FORM**

Bidder's Organization Name: Hews Company, LLC		
Chief Executive - Name/Title: Robert E. Hews, President		
Tel: 207-767-2136	Fax: 207-767-5381	E-mail: bhews@hewscsco.com
Headquarters Street Address: 190 Rumery Street		
Headquarters City/State/Zip: South Portland, ME 04106		
<i>(provide information requested below if different from above)</i>		
Lead Point of Contact for Bid - Name/Title:		
Tel:	Fax:	E-mail:
Street Address:		
City/State/Zip:		

By signing below Bidder affirms:

- Their bid complies with all requirements of this RFQ; and
- This bid and the pricing structure contained herein will remain firm for a period of 180 days from the date and time of the bid opening; and
- That no personnel currently employed by the Department or any other State agency participated, either directly or indirectly, in any activities relating to the preparation of the Bidder's proposal; and
- That no attempt has been made or will be made by the Bidder to induce any other person or firm to submit or not to submit a proposal; and
- The undersigned is authorized to enter into contractual obligations on behalf of the above-named organization.

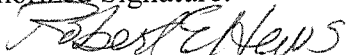
Name: Robert Hews	Title: President
Authorized Signature: 	Date: May 5, 2017



## Debarment, Performance, and Non-Collusion Certification

By signing this document I certify to the best of my knowledge and belief that the aforementioned organization, its principals, and any subcontractors named in this proposal:

- a. Are not presently debarred, suspended, proposed for debarment, and declared ineligible or voluntarily excluded from bidding or working on contracts issued by any governmental agency.
- b. Have not within three years of submitting the proposal for this contract been convicted of or had a civil judgment rendered against them for:
  - i. fraud or a criminal offense in connection with obtaining, attempting to obtain, or performing a federal, state or local government transaction or contract.
  - ii. violating Federal or State antitrust statutes or committing embezzlement, theft, forgery, bribery, falsification or destruction of records, making false statements, or receiving stolen property;
  - iii. are not presently indicted for or otherwise criminally or civilly charged by a governmental entity (Federal, State or Local) with commission of any of the offenses enumerated in paragraph (b) of this certification; and
  - iv. have not within a three (3) year period preceding this proposal had one or more federal, state or local government transactions terminated for cause or default.
- c. Have not entered into a prior understanding, agreement, or connection with any corporation, firm, or person submitting a response for the same materials, supplies, equipment, or services and this proposal is in all respects fair and without collusion or fraud. The above mentioned entities understand and agree that collusive bidding is a violation of state and federal law and can result in fines, prison sentences, and civil damage awards.

- **Failure to provide this certification may result in the disqualification of the Bidder's proposal, at the discretion of the Department.**

To the best of my knowledge all information provided in the enclosed proposal, both programmatic and financial, is complete and accurate at the time of submission.

Name: Robert Hews	Title: President
Authorized Signature: 	Date: May 5, 2017

Appendix B

STATE OF MAINE  
DEPARTMENT OF ADMINISTRATIVE AND FINANCIAL SERVICES  
DIVISION OF PURCHASES

DETAILED SPECIFICATIONS

RFQ # 17D 17040500000000000614

Purpose and Intent  
9Foot 3Inch Platform Body

The purpose and intent of this specification is to describe minimum 9'3" Platform Body with fixed bulkhead and removable stake sides. Specifications include four options to be priced separately. Option one (1) a lift gate with a minimum of 1600 Lbs. capacity. Option two (2) is a pull down step that can be stored in place when not in use. Option three (3) is a hinged Swing Gate Kit. Option four (4) is a hydraulic body hoist with a minimum 6 ton capacity. Option five (5) is installing cost. Bodies will be mounted on a latest model year Ford F-350 with 60" CA dimension, 14,000 lb. GVW rating, dual rear wheels, gas or diesel engine and automatic transmission. MaineDOT estimates eleven (11) units however the state reserves the right to order more or less as needed (depending on funding) for two calendar years. Individual stake bodies may be purchased separately or with any combination of listed options. Individual options may be ordered to be installed on platform bodies already in MaineDOT service.

**Completeness**

The price quoted in any proposal submitted shall include all items of labor, materials, and other costs necessary to fully complete the manufacture and delivery of the platform/rack body pursuant to these specifications.

Any part or detail which makes the platform/rack body complete and ready for service shall not be omitted, even though such part or detail is not mentioned in these specifications.

**Conformity**

All parts not specified shall be manufacturer's best quality and shall conform in materials, design, or workmanship to the best practice known in the platform/rack body industry. All parts shall be new and in no case will used, reconditioned or obsolete parts be accepted. The parts on all platform/rack body provided by the manufacturer should be interchangeable.

INSTRUCTIONS FOR COMPLETING TECHNICAL SPECIFICATION SHEET

Please complete the checklist for technical specifications set forth below. Each Bidder must indicate whether it can meet the technical specifications by inserting an “X” next to each specification. The “X” will demonstrate that the Bidder’s offering meets the technical specification. If a Bidder cannot meet a technical specification, then the Bidder must give an explanation for each exception and for equipment that is not available or that will be dealer installed. All explanations must be provided in detail on separate pages along with the justification as to why the alternative equipment or deliverables will be as good as the equipment or deliverables described in the detailed specifications for desired items. A copy of the vendor specification proposal must be provided. Following these instructions is essential for proper bid evaluation. **If a Bidder fails to provide requested information or if information on a quote is found to be false or misleading, the quote will be rejected as unresponsive. The award will be made on a best value basis to the vendor that either meets or most closely meets the specifications, while taking price and delivery into consideration.**

The following abbreviations must be used by interested Bidders:

<b>X</b>	<b>Meeting Specification</b>
<b>N/A</b>	<b>Not Available</b>
<b>DI</b>	<b>Dealer Installed</b>
<b>AE</b>	<b>Approved equal process</b>

**Section 1 Construction**

- 1.1 Endrails and side rails shall be a minimum of 5 5/8” 12ga. high strength steel.
- 1.2 Crossmembers shall be a minimum of 4 inch 11ga. high strength “C” channel.
- 1.3 Crossmember spacing shall be a minimum of every 24 inches.
- 1.4 Gussets shall be front and rear rails along with every other crossmember.
- 1.5 Longsills shall be a minimum of 4 inch 10ga. formed channel, and install with a minimum of 34 inch spacing, minimum length shall be 116”.
- 1.6 Flooring shall be 2 inch x 6 inch tongue and groove treated dense pine.
- 1.7 Lights shall be LED and recessed mounted in shock resistant rubber grommets and loom protected wires.
- 1.8 Stake pockets shall be 1.7 inch x 3.75 inch reinforced on 24 inch centers.
- 1.9 Stake racks shall be a minimum of 40 inches high
- 1.10 Stakes shall be made from a minimum of 14 ga. galvanized steel.
- 1.11 Slats shall be made from a minimum of 16ga. steel and roll formed.
- 1.12 Attaching hardware shall be spring loaded, anti-rattle, heavy duty hardware.
- 1.13 Bulkhead shall be rectangular drop in 40 inches high and 96 inches wide with Hole Punched or Mesh center window.
- 1.14 Bulkhead shall have minimum 12” reinforced Cab Plate to support accessories such as Ladders and Emergency Lights - 12” footprint, flat on top.
- 1.15 Bulkhead shall be welded in place to the front rub rail.

- X 1.16 Hitch shall be a class V, rated up to 13,500 lbs. gross trailer weight, with 7-prong Round pin trailer plug-in (See wire Diagram). RV plugs will not be accepted.
- X 1.17 All components shall be E-Coat priming and corrosion protection.
- X 1.18 No wiring shall run through the stake pockets or an area where it can be pinched
- X 1.19 All exterior trailer wiring shall be professionally installed and run in suitable weather resistant loom or conduit (professionally secured).
- X 1.20 All wire splices /connectors (if applicable) shall be shrink tube barrel type or soldered and shall be sealed with weather proof automotive type shrink tubing, Scotch lock type (wire piercing) connectors are not acceptable in any application

Circuits	Code #	Marking	Color Code
Ground	1	W	White
Clearance, Side Marker & Identification Lamps	2	BK	Black
Left Turn & Hazard Signal	3	Y	Yellow
Stop Lamps & Anti-Lock Devices	4	R	Red
Right Turn Signal & Hazard Signal	5	G	Green
Tail, Rear Clearance Marker, & Plate Lamps	6	BR	Brown
Auxiliary Circuit	7	BL	Blue

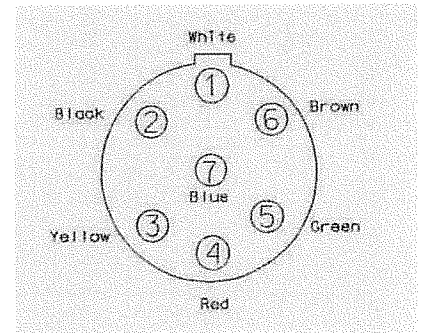

- X 1.21 Hitch shall use a 2-1/2" square receiver opening.
- X 1.22 Hitch shall attach to the vehicle frame only.

**Section 2 Warranty**

- X 2.1 Manufacture’s standard warranty will apply.
- X 2.2 Terms and conditions of warranty must be provided with bid proposal.
- X 2.3 Manufacturer’s warranty will start with the in-service date.

**Section 3 General**

- X 3.1 Bid price of body shall include mounting and all hardware to install on latest model Ford F350 with a 60 inch CA with dual wheels and delivery to Maine DOT Fleet Services in 66 Industrial Drive Augusta, Me.
- X 3.2 Body and all components shall be black in color.
- X 3.3 Be it known that these specifications are a minimum and that bids will be evaluated based on price, warranty, manufacturers performance data, delivery schedule, parts availability and other items deemed appropriate.

- 3.4 Bidders are required to provide sufficient information with their bid such as manufacturer's brochures, specification sheet, etc. and to certify that they have service facilities in Maine, staffed with trained service technicians and stocked with repair parts for the equipment which is bid. Failure to provide this information may cause the bid to be rejected. Maine DOT reserves the right to reject any and all bids.
- 3.5 Body must comply with the Department of Transportation Federal Motor Vehicle Safety Standards and Department of Labor Occupational Safety and Health Standards. Lighting equipment shall meet FMVSS # 108.
- 3.6 Exceptions to specifications shall be listed on a separate paper and noted as exceptions and submitted with bid proposal. If exceptions are not listed as such it shall be considered that the vendor will comply with all specifications as listed.
- 3.7 Backup alarm conforming to SAEJ 994 and OSHA requirements

**Options: Section 4, 5, 6, & 7**

**Section 4 Lift Gate**

- 4.1 Lift gate shall have a minimum capacity of 1600 Lbs.
- 4.2 Lift gate shall be a minimum of 82 inches wide and 36 inches in height.
- 4.3 Lift gate shall have cam activated power close.
- 4.4 Lift gate shall include latch chains for transit.
- 4.5 Lift gate shall have adjustable cylinder rod and clevis.
- 4.6 Lift gate shall meet TMC electrical requirements.
- 4.7 Power source for controlling the movement of the lift gate shall be a 12-volt self-contained hydraulic pump.
- 4.8 Lift gate shall conform to fit rack body specifications above (non-dumping).
- 4.9 Lift gate and components shall be black in color.

**Section 5 Step**

- 5.1 Step shall be a pull out and flip down type with a minimum weight capacity of 350 Lbs.
- 5.2 Step shall have a minimum of two (2) rungs spaced no more than 12 inches apart.
- 5.3 Step shall be a minimum of 11 inches in width.
- 5.4 Step shall be stored with-in or under the body frame and have a mechanism to prevent losses of step while the vehicle is in motion.
- 5.5 Step shall have a grip surface to provide for maximum traction.
- 5.6 Ladder will be located at the right rear corner of the body facing the rear.

**Section 6 Swing Gate**

- 6.1 Swing Gate shall be galvanized steel posts and slats; rear swing gates with a heavy duty bolt-on hinge assemblies.

**Section 7 Body Hydraulic Hoist**

- 7.1 Hydraulic hoist shall have a minimum 6 ton capacity with integral safety prop.
- 7.2 Power source for controlling the movement of the hydraulic hoist dump shall be a 12-volt self-contained hydraulic pump.
- 7.3 Dump/Hoist assembly shall be of lowest type mounting available but should not preclude a sub frame if necessary.
- 7.4 Body support, permanently attached, capable of being locked in place.
- 7.5 Power up and down.
- 7.6 Body longitudinal must not be cut to accommodate the hoist assembly.

Body Make & Model No. Reading H9W \$ 3,845.00 each

**Installed OPTIONS (additional cost):**

- 1-Lift gate system - Model Eagle Lift E50-91 \$ 2,515.00 each; installation add: \$730.00
- 2-Step system – Model EZ Step TRA 3000 \$ 255.00 each; installation add: \$ 85.00
- 3-Swing Gate – Model Rdg Rack Rear Swing DS \$ 465.00 each; installation add: \$100.00
- 4-Hydraulic Hoist Model Reading RTB-813 DAE \$ 2,125.00 each; installation add: \$825.00
- 5-Labor to install complete body, bumper, hitch and delivered. Price: \$ 1,475.00

Please list any and all exceptions to the above specification: \_\_\_\_\_  
**SEE ATTACHED EXCEPTIONS SHEET**  
\_\_\_\_\_

**Expected Delivery date is** 50 to 60 days after notice of award.

**VENDOR NAME:** Hews Company, LLC

**VENDOR ADDRESS:** 190 Rumery Street  
South Portland, ME 04106  
\_\_\_\_\_

**TELEPHONE NUMBER:** 207-767-2136

**CONTACT PERSON:** Bob Hews/Dave Gain

**E-MAIL:** bhews@hewsc.com

Rev/dar4-17



190 RUMERY STREET  
SOUTH PORTLAND, ME 04106  
TEL (207) 767-2136  
FAX (207)767-5381

2 RYAN ROAD  
BOW, NH 03304  
TEL (603) 226-3252  
FAX (603) 224-6279

Made to Order. Made to Last.

1-800-234-4397  
Email: [info@hewsc.com](mailto:info@hewsc.com)

May 5, 2017  
U70634

**BID 17D 17040500000000000614 – ITEM 1  
BODY SPECIFICATIONS – EXCEED OR EQUAL TO**

THE HEWS COMPANY, LLC’S BODY SPECIFICATIONS ARE EQUAL TO OR EXCEED THE 9’ STAKE BODY WITH FIXED BULKHEAD AND REMOVABLE STAKE SIDES REQUIREMENTS, AS SUMMARIZED BELOW:

- 1.1 EXCEED Endrails and Side Rails: 5 ¾”; 11 ga A40/A60 Galvannealed End and Side Rails
- 1.2 EXCEED 4¼” CM – “G” CHANNEL
- 1.3 EXCEED Cross Member Spacing: 13” Centers
- 1.4 EQUAL TO
- 1.5 Longsills: 6” 8.2# Structural Steel; length, 114”
- 1.6 Wood Floor: Ship Lap – treated dense pine – 2”
- 1.7 EQUAL TO
- 1.8 EQUAL TO
- 1.9 Racks: 42” High
- 1.10 EQUAL TO
- 1.11 EQUAL TO
- 1.12 EQUAL TO
- 1.13 Bulkhead: 42”
- 1.14 EQUAL TO
- 1.15 EQUAL TO
- 1.16 EQUAL TO
- 1.17 EQUAL TO
- 1.18 EQUAL TO

Appendix C

STATE OF MAINE  
DEPARTMENT OF ADMINISTRATIVE AND FINANCIAL SERVICES  
DIVISION OF PURCHASES

COST RESPONSE

**RFQ # 17D 17040500000000000614**

**PLATFORM RACK BODY**

Please fill out all required sections of this word document and attach to your response in Vendor Self Service, put in unit price and delivery days and submit your bid.

Please put the price in of the unit without the Options. Please attach a quote with the Options pricing.

**The Hews Company is a Maine-based manufacturing company, and per CFR Part 566, Manufacturer Identification, we are registered with the National Highway Traffic Safety Administration (NHTSA- updated 10/13/2016).**

**Federal Tax ID #: 01-0539757**

**DOT #: 57034**

**National Institute for Automotive Service Excellence (ASE) Certified Technicians: 12**

**The Hews Company is proud to be recognized by the National Truck Equipment Association (NTEA) Member Verification Program since 2010. MVP status is recognition of outstanding business practices, successful implementation of quality standards, and compliance with federal regulations.**







**HEWS COMPANY, LLC**  
 190 RUMERY STREET  
 SOUTH PORTLAND ME 04106  
 PHONE: (207) 767-2136  
 FAX: (207) 767-5381

ATTN:TERRY DEMERCHANT  
 MAINE DEPT OF TRANS-AUGUSTA  
 STATE HOUSE STATION 26  
 105 CAPITAL STREET  
 AUGUSTA ME 04333-0026

Quote Date: 05/04/17  
 Order #: U70634  
 Sales Rep: ROBERT HEWS  
 Customer #: 13246  
 Telephone #: 207-624-3132  
 Fax #: 207-287-8757

RFQ# 17D 17040500000000000614  
 BID DUE: 5/5/2017 AT 2:00PM

- 1 - 9' STAKE BODY MODEL: H-9-W HEAVY DUTY
  - Length: 9' 5 1/2" Width: 96"
  - Racks: 42" High Steel-Black-Quick release on post.
  - Headboard: 42" Stand alone steel front bulkhead w/braces-welded at front.
  - Window in front bulkhead, 12" reinforced cab shield.
  - Floor: 2x6 ship lap treated dense pine.
  - Cross members 4 1/4" x 11 ga - 13" centers with gussets.
  - Longsills: 6" Structural channel (8.2 lbs per foot) and 114" long, 34" o/c.
  - LED Marker lights, reflectors, loom.
  - Triple protection - A60 Galvanealed steel, E-Coat primer, and Black Powder Coat finish coat.
  - Three-year limited warranty.
  
- Hitch s & c channel, class V, receiver, 7 prong round plug, 2 1/2" square openings, safety chain holders. (Kit.)
- Back up Alarm.
- Body mount kit - U bolts - Oak Frame Strips.
- ICC bumper, rear flaps, flap brackets, anti-sail, flaps.

NOT INSTALLED, FOB, AUGUSTA, ME \$3,845.00 ea

OPTION (LINE 5):

- 1. INSTALL LABOR: BODY, RACKS, HEADBOARD, CAB SHIELD, HITCH, BACK-UP ALARM AND PAINT NEW WORK ADD: \$1,475.00

SALESPERSON: BOB HEWS / DAVE GAIN DELIVERY TIME: 50 TO 60 DAYS

VIN:	TBD	FLEET ID:	
MAKE/MODEL:	FORD F350	YEAR:	2017
TRANS:	AUTOMATIC	ENGINE:	GAS
GVW:	14,000	CA:	60"

**Please sign order and return 1 copy**

TERMS:  
**N30**

Sub-Total	3,845.00
F.E.T.	0.00
Sales Tax	0.00

\_\_\_\_\_  
 Signature Date

**Total 3,845.00**

# Platform Options

## Optional Bulkheads

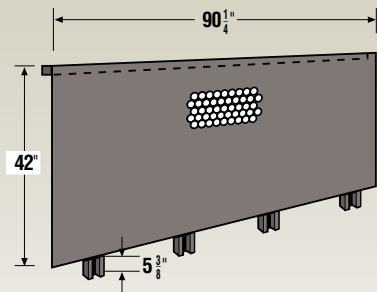

### Solid

12 Gauge bulkhead with 14 gauge posts. Also available in 30", 48" & 52" heights

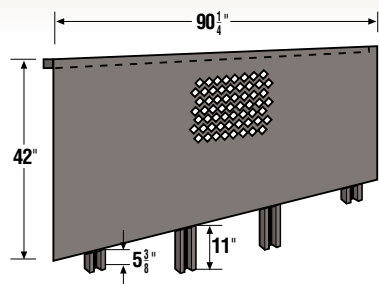

### Solid Long Sill Reinforced:

12 Gauge bulkhead with 14 gauge posts, with two center posts extending down along side of platform long sills. Also available in 48", 52" & 60" heights

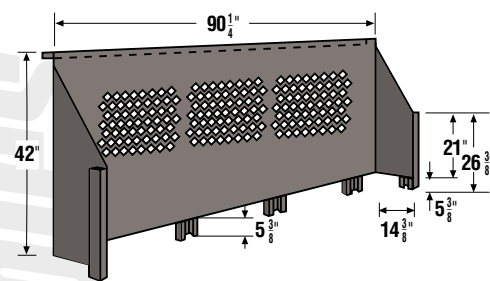

### Solid Winged

12 Gauge bulkhead with 14 gauge posts. Wings provide additional support to bulkhead. Also available in 48" & 52" heights

Optional window (10" x 20" or 195/8" x 233/4") available at additional cost  
**\*195/8" x 233/4" Windows are available in a single or triple window configuration (triple shown in "solid winged" illustration)**

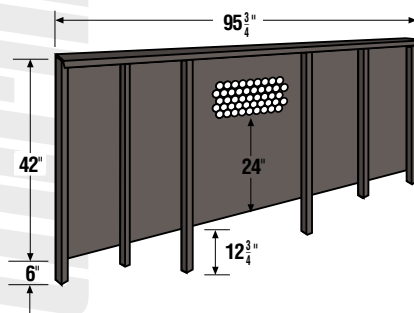

### Extra Heavy-Duty

10 Gauge bulkhead with six 3" posts of 4.1 structural steel channel. Optional 11" x 27" window available at additional cost. Bulkhead is available for extra-heavy-duty stake bodies and OEH models 903/4" wide. Also available in 48", 52", & 60" heights

## Optional Equipment



### Rear swing-out racks

Permits rear racks to open freely without lifting them out of the stake pockets.

### RTB-813 subframe hoist

- Double-acting (power-up/power-down) 12-Volt electric hydraulic power unit for ease of operation
- Hydraulic pump, plumbing and wiring included with complete hoist package
- Large diameter cylinder for increased hydraulic pressure and maximum lifting capacity
- Concentrated seal and cylinder packing for leak free operation
- Low mount subframe easily attaches to chassis truck frame
- Black Powder Coat Finish
- Backed by 3 Year limited warranty for ownership confidence

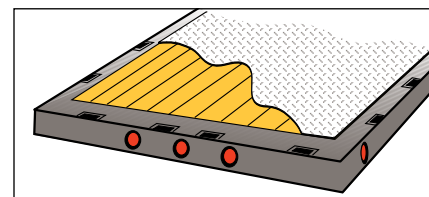

### Deck overlay

3/16" Deck plate steel over wooden floor

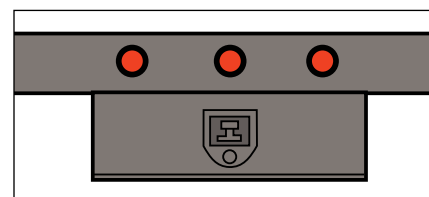

### "Possum belly" compartment

10" long storage tunnel under platform and between long sills. Access is available through a rear hinged door

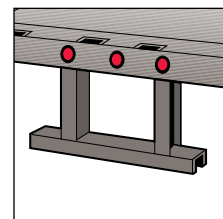

ICC bumper

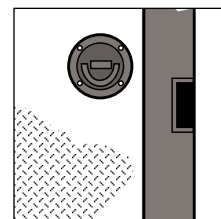

Heavy-duty recessed tie-down rings

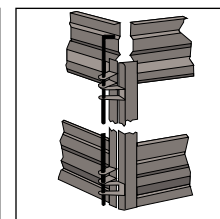

Lift up swing-out hinges

### Available on Special Order:

- Oxygen and acetylene bottle storage compartments
- Extra crossmembers (12" centers)

# Dimensional Data

96" Width Heavy-Duty Platforms					
Size	Model	Cab-to-Axle	Floor Type	Platform Weight	Rack Weight
9'	H9P	60"	3/16" Smooth Steel	1,075lbs.	375lbs.
	H9D		3/16" Deck Plate	1,155lbs.	
	H9W		2" (nominal) Wood	830lbs.	
10'	H10P	60-72"	3/16" Smooth Steel	1,160lbs.	410lbs.
	H10D		3/16" Deck Plate	1,235lbs.	
	H10W		2" (nominal) Wood	885lbs.	
12'	H12P	84"	3/16" Smooth Steel	1,395lbs.	490lbs.
	H12D		3/16" Deck Plate	1,490lbs.	
	H12W		2" (nominal) Wood	1,065lbs.	
14'	H14P	102-108"	3/16" Smooth Steel	1,620lbs.	545lbs.
	H14D		3/16" Deck Plate	1,735lbs.	
	H14W		2" (nominal) Wood	1,225lbs.	
16'	H16P	114-126"	3/16" Smooth Steel	1,850lbs.	580lbs.
	H16D		3/16" Deck Plate	1,990lbs.	
	H16W		2" (nominal) Wood	1,455lbs.	
18'	H18P	120-132"	3/16" Smooth Steel	2,040lbs.	640lbs.
	H18D		3/16" Deck Plate	2,200lbs.	
	H18W		2" (nominal) Wood	1,530lbs.	
20'	H20P	137-149"	3/16" Smooth Steel	2,235lbs.	695lbs.
	H20D		3/16" Deck Plate	2,410lbs.	
	H20W		2" (nominal) Wood	1,665lbs.	
22'	H22P	146-158"	3/16" Smooth Steel	2,640lbs.	760lbs.
	H22D		3/16" Deck Plate	2,655lbs.	
	H22W		2" (nominal) Wood	1,835lbs.	
24'	H24P	165-192"	3/16" Smooth Steel	2,690lbs.	820lbs.
	H24D		3/16" Deck Plate	2,900lbs.	
	H24W		2" (nominal) Wood	2,005lbs.	

### Heavy-Duty Platform Construction

Longitudinal sills of structural steel channel ranging from 6" 8.2lbs. to 8" 11.5lbs. Crossmembers are of 11 gauge roll formed "G" channel on 15" centers (average). 5-3/4" High rails are roll formed of 11 gauge A40-A60 two-sided coated steel. Each stake pocket is reinforced with a 12 gauge steel box welded into the rails.

Extra Heavy-Duty Platforms (96" width for all platforms)						
Size	Model	Model w/ outside stake pockets	Cab-to-Axle	Floor Type	Platform Weight	Rack Weight
12'	EH12P	OE12P	84"	3/16" Smooth Steel	1,915lbs.	350lbs.
	EH12D	OE12D		3/16" Deck Plate	2,010lbs.	
	EH12W	OE12W		2" (nominal) Wood	1,585lbs.	
14'	EH12P	OE12P	102-108"	3/16" Smooth Steel	2,205lbs.	390lbs.
	EH12D	OE12D		3/16" Deck Plate	2,340lbs.	
	EH12W	OE12W		2" (nominal) Wood	1,830lbs.	
16'	EH16P	OE16P	114-126"	3/16" Smooth Steel	2,530lbs.	430lbs.
	EH16D	OE16D		3/16" Deck Plate	2,670lbs.	
	EH16W	OE16W		2" (nominal) Wood	2,065lbs.	
18'	EH18P	OE18P	120-132"	3/16" Smooth Steel	2,790lbs.	480lbs.
	EH18D	OE18D		3/16" Deck Plate	2,950lbs.	
	EH18W	OE18W		2" (nominal) Wood	2,280lbs.	
20'	EH20P	OE20P	137-149"	3/16" Smooth Steel	3,055lbs.	520lbs.
	EH20D	OE20D		3/16" Deck Plate	3,225lbs.	
	EH20W	OE20W		2" (nominal) Wood	2,480lbs.	
22'	EH22P	OE22P	146-158"	3/16" Smooth Steel	3,355lbs.	560lbs.
	EH22D	OE22D		3/16" Deck Plate	3,555lbs.	
	EH22W	OE22W		2" (nominal) Wood	2,730lbs.	
24'	EH24P	OE24P	165-192"	3/16" Smooth Steel	3,670lbs.	610lbs.
	EH24D	OE24D		3/16" Deck Plate	3,880lbs.	
	EH24W	OE24W		2" (nominal) Wood	2,985lbs.	

### Extra Heavy-Duty Platform Construction

Structural steel channel long sills range from 7" 9.8lbs. to 8" 11.5lbs. Crossmembers are of structural steel channels on 12" centers. 6" High outer rails are die-formed of 7 gauge steel. Each stake pocket is reinforced with a 10 gauge steel box welded into the side rails and will accept a 2" x 4" stake. Outside stake pockets allow full utilization of the platform floor. The outside side rails are reinforced with a 2" x 3/8" steel tie bar for securing loads.



— NO BODY BETTER —

*Thank you for purchasing a Reading product.*

# LIMITED WARRANTY



## **Benefits of Registering your Reading Product:**

- We maintain a record of your purchase and can assist if any questions arise
- Your feedback can drive product enhancements
- Our goal is 100% satisfaction. Should you have any concerns regarding your Reading product, a Reading representative will contact you

Made in the USA



# HERE ARE YOUR KEYS AND YOUR READING BODY WARRANTY!

## What is Covered Under the Reading Limited Warranty?

- Steel body manufactured after 2/16/04 – 6 years
- Hybrid bodies are covered for a period of 6 years
- Aluminum body manufactured after 6/30/08 – 10 years
- Platform, Landscaper SL, Stake Rack, Dump Bodies, Redi-Dek, Tool Boxes – 3 years
- Pick-up Caps – 5 years

Reading warrants its factory applied powder coat finish against material defects for 3 years or 36,000 miles whichever occurs first from the date of purchase.

Reading warrants its products to be free of rust-through perforation for the life of the warranty.

Reading warrants only its own products that are manufactured in its own facility for the time period outlined. Vendor-supplied components, such as locks, hinges, lights, hoists, etc, are solely covered by the vendor's explicit warranty. Reading does not extend beyond the vendor supplied warranty.

This limited warranty applies only when the product is properly installed by an Authorized Reading Truck Body installer and is properly maintained and used for the purpose for which it was designed. The warranty period begins on the date of purchase from the first owner/user or one year from the date the product was shipped from the Reading Truck Body manufacturing plant, whichever comes first.

## Who Benefits from this Warranty?

The Reading obligation under this warranty applies to the first purchaser of the product of the vehicle during the warranty period.

## How is a Warranty Claim Handled?

The purchaser shall immediately notify the local Authorized Distributor. The Purchaser or the Distributor can submit the claim using the form on [www.readingbody.com/warranty-info/make-a-claim](http://www.readingbody.com/warranty-info/make-a-claim). The claim must include the model and serial number of the body, provide a detailed description of the problem and provide photographs of the entire unit including shots of the specified defect. All repairs must be authorized by Reading Truck Body prior to any work being completed.

If after the claim is reviewed, and Reading determines the product is defective in material or workmanship as claimed, Reading shall have the option to repair the defect or replace the product or any part. Reading shall not be liable for any rental reimbursement, loss of vehicle use, inconvenience, storage, lost time/pay, etc.

## Exclusions to Warranty

1. Accessories or services not furnished by Reading, or damages/corrosions caused by these accessories or services. This includes optional parts, aftermarket products, components, installation, finish painting, lettering, wiring or modifications.
2. Specific non-rust-through and paint warranty exclusions:
  - Products which may have been used to carry corrosive materials, where such materials may result in corrosion or rust-through perforation
  - Paint warranty void if product purchased in prime paint and finished by the original owner
  - If an aftermarket liner coating is applied to the body the paint warranty will be voided due to the requirements of the liner
  - Products being warranted under the rust-through warranty must have a perforation through the metal

- Rust on a painted surface is not considered a rust-through warranty
  - Damage or corrosion caused by airborne fallout, salt from the sea air, salt or other materials used to control road conditions, chemicals, tree sap, stones, hail, earthquake, water or flood windstorm, lightning, the application of chemicals or sealants subsequent to manufacture are not covered or normal wear and tear on the product
  - Damages due to the failure to follow the recommended maintenance schedule of lubricating the hinges, locks and lock cylinders
3. Damage due to accident, misuse, abuse or alteration of the product.
  4. Fatigue cracking of the body structure caused by improper mounting, overloading, severe off-road applications, twisting loads influenced by cranes or aerial devices. The twisting exceeds the factory body twist allowance.
  5. Products purchased and used outside the United States and Canada.
  6. Products not properly maintained per maintenance instructions.
  7. Platforms only – wood floors that are found defective, in which case the replacement cost to Reading shall be limited to the following percentages:
    - 100% First year
    - 50% Second year
    - 25% Third year
  8. The SMART Racks on Reading platform bodies are covered for a period of 5 years.
  9. Translucent roofs are covered for a period of 1 year, unless misused or modified in any way.
  10. Factory bed liners are covered for a period of 1 year, unless misused or modified in any way.

## Disclaimers

Reading Truck Body, LLC warrants its products only as stated in this warranty. Reading makes no other warranties, express or implied and disclaims all other warranties, including any implied warranty of merchantability or fitness for particular purpose.

Reading obligations are limited to those expressed in this warranty, and Reading shall not be liable to the purchaser or any third party for any direct or indirect, incidental or consequential damage or loss.

Some states do not allow limitations on how long an implied warranty lasts or exclusions or limitations of incidental or consequential damages so the above limitations or exclusions may not apply to you. This warranty gives you specific legal rights and you may also have other rights which may vary from state to state.

If the product is improperly installed, modified, misused, damaged or otherwise tampered with, the foregoing warranty shall lapse and become null and void.

This warranty shall be enforced and construed in accordance with the laws of Pennsylvania.

No person is authorized to modify or add to the foregoing warranty.



# READING HAS A FULL LINE OF TRUCK BODIES TO CHOOSE FROM ...



Classic II Service Body – Steel and Aluminum



Classic Service Van – Aluminum



Cranemaster 3200 Body



Ready Van SL – Steel



Platform Body



Redi-Dek Body



Marauder Dump Body



Landscaper SL Body

(Some models shown with optional equipment)

## HOW TO LOCATE:

**Reading Serial No.** - Located in the curbside horizontal compartment on the second front partition.

**Key No.** - The key number can be found on the side of the key. The following procedure must be followed to locate the lock key number if the keys are lost. Open any door and remove the lock cover located on the inside of the door. Locate the cylinder (which is positioned at the end of the linkage rod). The key number will be found on the flat side of the cylinder.

Sold and serviced locally by:

Appendix D

STATE OF MAINE  
DEPARTMENT OF ADMINISTRATIVE AND FINANCIAL SERVICES  
DIVISION OF PURCHASES

Municipality Political Subdivision and School District  
Participation Certification

RFQ # 17D 1704050000000000614

PLATFORM RACK BODY

The Division of Purchases is committed to providing purchasing opportunities for **municipalities, political subdivisions and school districts** in Maine by allowing them access, through our vendors, to our contract pricing. A bidder's willingness to extend contract pricing to these entities will be taken into consideration in making awards.

Will you accept orders from political subdivisions and school districts in Maine at the prices quoted?

Yes

Yes with conditions as follows:

No

Name of Company:

Hews Company, LLC

Address:

190 Rumery Street, South Portland, ME 04106

Signature: 

Date: May 5, 2017

**APPENDIX E**

**RFQ # 17D 17040500000000000614**

**CERTIFICATIONS**

**1.0 NONCOLLUSION BIDDING CERTIFICATION**

By submission of this Bid, each Bidder and each person signing on behalf of any Bidder certifies, and in the case of a joint bid, each party certifies as to its own organization, under penalty of perjury, that to the best of its knowledge and belief:

1. The prices in this Bid have been arrived at independently without collusion, consultation, communication or agreement, for the purpose of restricting competition as to any other matter relating to such prices with any other Bidder or with any other competitor;
2. Unless otherwise required by law, the prices which have been quoted in this Bid have not been knowingly disclosed by the Bidder and will not knowingly be disclosed by the Bidder prior to opening, directly or indirectly, to any other Bidder or to any competitor; and,
3. No attempt has been made or will be made by the Bidder to induce any other person, partnership or corporation to submit or not to submit a Bid for the purpose of restricting competition.

May 5, 2017

Dated

Robert E. Hews

Printed name of Person Bidding

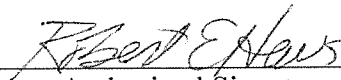

Authorized Signature

President

Title



**NAME/LOCATION OF REPAIR FACILITY(S)** (BOTH AUTHORIZED WARRANTY,PARTS & SERVICE PER REQUESTED LOCATION). These facilities must be located within a 75-mile radius of the equipment location:

WARRANTY AND SERVICE FACILITY Hews Company, LLC

ADDRESS 190 Rumery Street, South Portland, ME 04106

CONTACT NAME Tom Buckland TELEPHONE 207-767-2136

EQUIPMENT PARTS PROVIDER: Hews Company, LLC

ADDRESS: 190 Rumery Street, South Portland, ME 04106

CONTACT NAME: Dave Gain TELEPHONE: 207-767-2136

This form must be reproduced and completed for any additional equipment warranty/facility information.

May 5, 2017  
Dated

*Robert E Hews*  
Signature

Robert E. Hews  
Print Name

Hews Company, LLC  
Company Name

**3.0 SPECIFICATION COMPLIANCE**

The bidder hereby certifies that the equipment(s) being bid in response to this invitation meet or exceed these specifications and that where a deviation from the specifications exists, the bidder has obtained written approval of those exceptions prior to submitting this bid.

If a conflict exists between these specifications and Federal and/or State laws, the Federal and/or State laws shall prevail and the bidder must alert the purchaser to any such conflicts.

May 5, 2017  
Date

Robert E. Hews  
Printed Name of Person Bidding

Robert E Hews  
Signature

President  
Title

## APPENDIX F

### RFQ # 17D 1704050000000000614

#### MAINEDOT TERMS AND CONDITIONS

##### A. AGREEMENT

The Vendor shall deliver the equipment ordered in accordance with this Agreement and governed by these Terms and Conditions.

##### B. INDEPENDENT CAPACITY

In providing the equipment under the Agreement, the Vendor shall act independently and not as an agent of the State of Maine.

##### C. PAYMENT AND OTHER PROVISIONS

MaineDOT anticipates paying the selected Vendor for goods and services received, on the basis of net 30 payment terms following acceptance of the equipment, the receipt of an acceptable title and required documents, and an accurate and acceptable invoice. An invoice will be considered accurate and acceptable if it contains the State of Maine Agreement number, correct pricing information relative to the Agreement, and provides any required supporting documents, as applicable, and any other specific and agreed-upon requirements listed within the Agreement.

MaineDOT reserves the right to pay for the equipment purchased by any of several available means, which include but may not be limited to check, EFT, and/or procurement card. Vendors are advised that state statute precludes sellers from imposing a surcharge on credit or debit card purchases (text follows):

“9-A MRSA §8-303 (2): A seller in a sales transaction may not impose a surcharge on a cardholder who elects to use a credit card or debit card in lieu of payment by cash, check or similar means.”

##### D. WARRANTY

For a period of one (1) year following equipment delivery and acceptance (the “Warranty period”), Vendor unconditionally warrants and guarantees that the equipment shall be free from defects in parts and workmanship. If MaineDOT discovers any defects during the Warranty period, the Vendor’s obligation will be to repair or replace the equipment or refund the purchase price, at MaineDOT’s sole option subject to the following requirements as applicable:

- Replacement will be with new equipment matching the specifications within this Agreement.
- Reimbursement will be for the total purchase price of the equipment including the cost of returning the equipment.
- All Repairs including the cost of transporting the equipment will be borne by the Vendor. All repairs will be warranted free from defects in parts and workmanship for a one year period following the repair.

The Vendor hereby assigns to MaineDOT the right to enforce all manufacturer’s warranties or guarantees on the equipment.

The Vendor agrees that the warranty obligations provided by this Agreement shall be reported as an outstanding obligation in the event of bankruptcy, dissolution, or the sale, merger, or cessations of operations of the Vendor.

In the event of a breach of Vendor’s warranty obligations, MaineDOT shall notify Vendor in writing of the breach and grant Vendor 30 days to cure the breach. Should Vendor fail to cure the breach, MaineDOT may pursue whatever remedies may be available.

**E. DAMAGES**

Time is of the essence in the delivery of the equipment specified herein, and in event of delay(s) in the delivery of the equipment beyond the date set forth in the Agreement, or beyond authorized extensions thereof MaineDOT may impose liquidated damages. Because it is difficult to determine the actual amount of the damage by reason of such delay it is therefore agreed that the Vendor will pay the sum of two hundred dollars (\$200.00) per unit for each calendar day(s) delay in delivery as liquidated damages and not as a penalty.

These damages shall be deducted from any monies due, or which may thereafter become due to the Vendor or may be recovered by through any lawful means.

**F. SET-OFF RIGHTS**

MaineDOT shall have all of its common law, equitable and statutory rights of set-off.

**G. FORCE MAJEURE**

Either party may be excused from performance under this Agreement to the extent the failure to perform is caused by acts of God or of the public enemy, fire, floods, epidemics, quarantine, restrictions, strikes, labor disputes, and freight embargos, or other causes beyond the party’s reasonable control. In the event of such event of force majeure, the affected party shall provide the other party written notice of the cause of delay within fifteen (15) days from the beginning of any such delay. The time of performance shall be excused to extent of the duration of any such event of force majeure, or such period of time as may be mutually agreed upon by the parties.

## H. INDEMNIFICATION

The Vendor shall indemnify and hold harmless the MaineDOT and its officers, agents, and employees from and against any and all claims, liabilities, and costs, including reasonable attorney fees, for any or all injuries to persons or property or claims for money damages, including claims for violation of intellectual property rights, arising from the negligent acts or omissions of the Vendor, its employees or agents, officers or Subcontractors in the performance of work under this Agreement; provided, however, the Vendor shall not be liable for claims arising out of the negligent acts or omissions of the MaineDOT, or for actions taken in reasonable reliance on written instructions of the MaineDOT.

This indemnification provision shall survive any termination or expiration of the Agreement.

## I. DEFAULT, TERMINATION

- i. MaineDOT reserves the right to terminate this Agreement or any part hereof, for its sole convenience. Thirty (30) days advance written notice shall be provided in the case of a termination for convenience. In the event of such termination, Vendor shall immediately stop all work hereunder and shall immediately cause any and all of its suppliers and subcontractors to cease work. Vendor shall be paid for all work on a percentage completed basis, as mutually agreed upon by the parties, up to the date of termination under this Paragraph 14.A.
- ii. The MaineDOT shall have the right to terminate this Agreement in the event of a material breach or default by Vendor of its obligations hereunder that is not cured within thirty (30) days from the date of receipt by Vendor of written notice of such breach from the MaineDOT. If the breach or default, by its nature, cannot be cured within such thirty (30) day period, then Vendor shall have such additional time (not to exceed thirty (30) additional days) as may be necessary to cure the breach or default, provided Vendor has exercised reasonable commercial efforts and taken appropriate action to begin cure of the breach or default within the initial thirty (30) day cure period.
- iii. The MaineDOT shall have the right to terminate this Agreement immediately upon written notice to Vendor in the event (i) Vendor, or any director, officer or employee of Vendor assigned to this Project is convicted of a criminal offense directly related to information technology services; or (ii) proceedings in bankruptcy are commenced against Vendor or if a receiver is appointed and such case or proceeding shall continue undismissed, or unstayed and in effect, for a period of one hundred twenty (120) days. Notwithstanding the foregoing, if a conviction of an employee assigned to this Project, officer or director, relates to individual and/or personal actions of such employee, officer or director and not the policy or directive of Vendor and, upon such conviction, Vendor shall terminate or otherwise remove

such employee, officer or director and take such other steps to reasonably ensure the propriety of Vendor' delivery of information technology services, then the MaineDOT shall not have a right to terminate this Agreement pursuant to the foregoing clause (i) of this Section 14 (C).

- iv. Vendor shall have the right to terminate this Agreement in the event of a material breach or default by the MaineDOT of its obligations hereunder that is not cured within thirty (30) days from the date of receipt by the MaineDOT of written notice of such breach from Vendor. If the breach or default, by its nature, cannot be cured within such thirty (30) day period, then the MaineDOT shall have such additional time (not to exceed thirty (30) additional days) as may be necessary to cure the breach or default, provided the MaineDOT has exercised reasonable commercial efforts and taken appropriate actions to begin cure of the breach or default within the initial thirty (30) day cure period.
- v. Vendor shall cause the foregoing provisions to be inserted in any subcontract for any work covered by this Agreement so that such provisions shall be binding upon each subcontractor, provided that the foregoing provisions shall not apply to contracts or subcontracts for standard commercial supplies or raw materials.

**J. DELIVERY AND ACCEPTANCE**

Time is of the essence in the delivery of the equipment. The Vendor shall execute the work continuously and diligently. Delivery of the units shall occur in accordance with the terms and conditions outlined in the resulting Agreement.

- i. Production of the units shall be conducted as a continuous production with no breaks or inserts of other orders or types of equipment.
- ii. Delivery shall be restricted to Monday through Friday, between the hours of 8 AM and 4 PM.
- iii. The Vendor will contact MaineDOT Fleet Services 24 hrs. prior to delivery with an estimated time of arrival.
- iv. Units furnished under this Agreement shall be delivered in first class condition, complete and ready for operation, and the Vendor shall assume all costs, responsibilities, and risk of loss related to damage that may have occurred in the delivery of the units.
- v. When units are delivered, certificates or releases signed by representatives of MaineDOT Fleet Services are understood to be a simple acknowledgment of receipt of the units only, and will NOT constitute an acceptance of the condition of the units or their conformance with the terms and conditions of the Agreement specifications.

- vi. Upon delivery, MaineDOT may conduct such tests as may be required to determine to its own satisfaction that the units appear to be in conformance with the terms, conditions, and requirements of the Agreement specifications.

Acceptance shall occur following final inspection by authorized employees of MaineDOT Fleet Service, receipt of the titles and all requested documentation. The Vendor will be notified, in writing, of acceptance/non-acceptance within fifteen calendar (15) days of delivery to the location specified in this Agreement.

#### **K. RIGHT TO SUSPEND WORK**

MaineDOT has the right to suspend any or all work at any time for any reason as it deems necessary. Consultant may receive payment for the portion of services completed through the date of suspension.

#### **L. COPYRIGHT AND LICENSES - PATENTS AND COPYRIGHTS**

Data and publication rights to any documents, produced under the terms of Agreement are the property of MaineDOT. The Vendor shall not copyright the material produced under the terms of the Agreement without written approval of MaineDOT, except to the extent necessary to protect its rights pursuant to the following paragraph.

The Parties to this Agreement mutually agree that, if patentable discoveries, intellectual property and software, or inventions should result from work described therein, all rights accruing from such discoveries or inventions shall be the sole property of the MaineDOT.

#### **M. CLAIMS AND DISPUTES**

##### **General**

To preserve any claim arising out of the Agreement, the Parties shall comply with and exhaust all provisions of this Section. Unless otherwise agreed to in writing, the Vendor shall continue to perform its services during any dispute resolution process. If the Vendor continues to perform, MaineDOT shall continue to make payments in accordance with the Agreement of amounts not in dispute.

##### **Negotiation with MaineDOT's Fleet Representative**

The Vendor shall promptly notify MaineDOT's Fleet Representative, or their designee, in writing, of disputes that could significantly affect scope, schedule or compensation. After such notice, the Vendor and MaineDOT's Fleet Representative shall promptly negotiate in good faith to resolve the dispute. MaineDOT's Fleet Representative will promptly issue a decision.

##### **Review by Director**

If the Vendor desires a review of MaineDOT's Fleet Representative's decision, then the Vendor shall promptly request in writing that MaineDOT's Director of the applicable Bureau or Office

review the Fleet Representative's decision. The Director or its designee(s) shall promptly notify the Vendor in writing of the result of the review.

**Dispute Resolution**

If the dispute remains unresolved after negotiation and review as set forth above, the Parties may proceed to mediation by selecting a mediator acceptable to both.

If the Parties are unable to resolve the dispute through mediation, either party may seek judicial review through a civil action commenced in the Superior Court of Maine, Kennebec County.

**N. CONTROLLING LAWS**

The Agreement referred to in these Terms and Conditions is governed by the applicable laws of the Federal Government and the State of Maine.

**Laws to Be Observed**

The Vendor shall comply with all applicable Federal, State and local laws, rules, regulations, orders, and ordinances affecting the work including, without limitation all environmental, wage, labor, equal opportunity, safety, patent, copyright, or trademark laws. The Vendor shall indemnify MaineDOT and hold MaineDOT harmless against any and all claims or liabilities arising from or based upon the violation or alleged violation of any such Law caused directly or indirectly by or through the Vendor.

**O. ENTIRE AGREEMENT/BINDING EFFECT/MODIFICATION/ASSIGNMENT**

This Agreement sets forth the entire agreement of the parties with regard to the subject herein. This Agreement may not be modified except by a written amendment executed by both parties.

Neither MaineDOT nor the Vendor may assign, sublet, or transfer any rights under or interest (including, but without limitation, monies that are due or may become due) in the Agreement without the written consent of the other, except to the extent that any assignment, subletting, or transfer is mandated or restricted by law. Unless specifically stated to the contrary in any written Consent To Assignment, no assignment shall release or discharge the assignor from any duty or responsibility under the Agreement.

**P. SEVERABILITY**

The invalidity or unenforceability of any particular provision or part thereof of this Agreement shall not affect the remainder of said provision or any other provisions, and this Agreement shall be construed in all respects as if such invalid or unenforceable provision or part thereof had been omitted.

**O. NON-WAIVER**

If MaineDOT fails or refuses to enforce any provision in the Agreement that shall not constitute a waiver of that provision, nor shall it affect the enforceability of that provision or of the remainder of the Agreement.





HEWS COMPANY, LLC  
 190 RUMERY STREET  
 SOUTH PORTLAND ME 04106  
 PHONE: (207) 767-2136  
 FAX: (207) 767-5381

ATTN:TERRY DEMERCHANT  
 MAINE DEPT OF TRANS-AUGUSTA  
 STATE HOUSE STATION 26  
 105 CAPITAL STREET  
 AUGUSTA ME 04333-0026

Quote Date: 05/04/17  
 Order #: U70636  
 Sales Rep: ROBERT HEWS  
 Customer #: 13246  
 Telephone #: 207-624-3132  
 Fax #: 207-287-8757

RFQ# 17D 17040500000000000614  
 BID DUE: 5/5/2017 AT 2:00PM  
 OPTION #1

- 1 - EAGLE LIFT MODEL E50-91
  - Capacity: 1600 Lb
  - Platform: 86 x 34 x 4 (38" total) Steel.
  - Quick release sure-hold safety locks.
  - Electric hydraulic pump, built in relief valves.
  - Oil impregnated bronze bushings at all pivot points.
  - 150 amp circuit breaker.
  - Power cut off integrated with vehicle switch. Toggle switch control.
  - Automotive Grade E Coat Black Topcoat paint.
  - Torsion spring assist folding.

NOT INSTALLED, FOB, AUGUSTA, ME

\$2,515.00 ea

OPTION:

- 1. INSTALL ON 9' PLATFORM WITH NO REAR RACKS  
 AND PROVIDE SIDE POST TIE-IN TO SIDE RACKS ADD: \$730.00

SALESPERSON: BOB HEWS / DAVE GAIN

DELIVERY TIME: 50 TO 60 DAYS

VIN: TBD FLEET ID:  
 MAKE/MODEL: FORD F350 YEAR: 2017  
 TRANS: AUTOMATIC ENGINE: GAS  
 GVW: 14,000 CA: 60"

Please sign order  
 and return 1 copy

TERMS:  
 N30

Sub-Total 2,515.00  
 F.E.T. 0.00  
 Sales Tax 0.00

Signature \_\_\_\_\_ Date \_\_\_\_\_

**Total 2,515.00**

# EAGLELIFT PALFINGER

## SPECIFICATIONS FOR 48" AND 50" SERIES "DOUBLE EAGLE" LIFTGATES 1,300 LB. AND 1,600 LB. CAPACITY

2/09

### (BOTH A LIFTGATE AND A DUMP-THRU TAILGATE)

Made for 2-3 yd. dump bodies, 3-4 yd. dump bodies, and small platform dumps. The "Double Eagle" comes in two lifting capabilities with three models in each capacity.

#### I. MODELS AVAILABLE

- |    |                           |                    |
|----|---------------------------|--------------------|
| A. | Model E48-78 Double Eagle | 1,300 lb. capacity |
| B. | Model E48-86 Double Eagle | 1,300 lb. capacity |
| C. | Model E48-91 Double Eagle | 1,300 lb. capacity |
| D. | Model E50-78 Double Eagle | 1,600 lb. capacity |
| E. | Model E50-86 Double Eagle | 1,600 lb. capacity |
| F. | Model E50-91 Double Eagle | 1,600 lb. capacity |

#### II. LIFTGATE FEATURES

- A. Bed height:
  - 48" series has a 48" maximum bed height
  - 50" series has a 50" maximum bed height
- B. Electrical connections: Electrical power source is supplied through the vehicle's parking lights. The liftgate is wired via the license plate light wires on the truck. Turning off the parking lights will prevent unauthorized operation of liftgate. The liftgate will not operate without the parking lights in the "ON" position. A 150-amp heavy-duty circuit breaker with manual reset is furnished to protect the battery and electrical system on the vehicle.
- C. Control switch: The control switch is mounted on the curbside of the truck. It is mounted on the outside of the upright and up high enough to be inaccessible to small children. The gate is controlled by a 3-way toggle switch; up-neutral-down.
- D. Plated cylinder shaft: chrome plated cylinder shaft to help prevent rusting
- E. Hydraulics:
  - 1. All hydraulics are totally enclosed in the housing of the liftgate for weather protection.
  - 2. Electric/hydraulic power unit has a built-in relief valve to prevent overloading of the liftgate while raising.
  - 3. An in-line flow control valve on the cylinder helps control the speed of the oil coming out of the cylinder returning to the reservoir when lowering the liftgate under loaded conditions.

# EAGLELIFT PALFINGER

## SPECIFICATIONS FOR 48" AND 50" SERIES "DOUBLE EAGLE" LIFTGATES 1,300 LB. AND 1,600 LB. CAPACITY

2/09

- F. Drop-away platform: platform of liftgate will "drop-away" for easy dock and forklift loading direct into truck bed.
- G. Gates are painted in black electrocoat topcoat.

### III. LIFTGATE SPECIFICATIONS

- A. Liftgate housing: 8 ga. steel front and 10 ga. steel rear
- B. Upright housing: 10 ga. upright steel
- C. Reinforced single-wall platform with torsion spring:
  - 12 ga. TPX steel load skin
  - Five – 10 ga. vertical reinforcing channels run the full height of platform
- D. Outer platform edge protection tube: 1-1/2" O.D. x 7/32" wall platform protection tube
- E. 7/8" dia. "D" hole pins with snap rings for arm pins
- F. Liftgate cable:
  - 1,300 lb. capacity liftgates have 1/4 dia., 6 x 36 (WS) stranded cable
  - 1,600 lb. capacity liftgates have 5/16 dia., 6 x 36 (WS) stranded cable
- G. Pulleys: upright pulleys are 4" dia. and housing pulleys are 4-1/2" dia.
- H. Cylinder: 1,300 lb. capacity cylinder has 1-3/4" bore with 17-3/8" stroke with 4-1/2" dia. pulley - 1,600 lb. capacity cylinder has 2-1/4" bore with 18" stroke with 4-1/2" dia. pulley
- I. Composite bushings: maintenance free bushings at all pivot points to eliminate the need for grease zerks and necessity of lubrication
- J. All retaining pins for pulleys, lift arms, cylinder trunnion and lift cables are to be retained by snap rings, not rivets, for easy accessibility
- K. Dump-thru tailgate release handle: single lever dump-thru tailgate release mechanism located on driver's side of truck. The operator is able to unlatch and latch standing clear of truck rear.

### IV. LIFTGATE OPTIONS

- A. Recessed light kits are available on all models
- B. 2-button hard wired hand-held control system with plug-in
- C. Aluminum treadplate platform
- D. Audible safety alarm



## WARRANTY AGREEMENT

### TYPE OF WARRANTY: FULL PARTS AND LABOR

PALFINGER Liftgates warrants its products to be free from defects in material and workmanship, when used in normal commercial service and when properly maintained during coverage schedule.

PALFINGER Liftgates will repair or replace any parts to be defective, the replacement part does not extend the warranty coverage period of the related Liftgate. Such replacement will be furnished without cost to the owners and the installation will be covered per a flat rate through an authorized PALFINGER repair facility. PLEASE CONTACT PALFINGER LIFTGATES FOR AUTHORIZATION BEFORE RETURNING ANY PRODUCT.

The warranty does not apply to any product that has been altered from its original design.

This warranty does not cover normal wear, maintenance or adjustment, damage or malfunction caused by improper handling, installation, abuse, misuse, negligence, or carelessness of operation.

There are not warranties which extend beyond the description of the face hereof, and PALFINGER Liftgates neither assumes nor authorizes any other person to assume for it any additional liability in connection with the sale of its products.

### EXCLUSIONS:

PALFINGER's warranty does not include the reimbursement for travel time, towing, vehicle rental, service calls, oil, batteries, fabricated parts, loss of income due to downtime, damage due to misuse or abuse, negligence, accidents, alterations, overtime expenses, routine maintenance or normal wear. Rust is not covered under warranty. Any parts that are found to be missing after the initial in-service date are not covered under warranty. Weak or dead batteries are not covered under warranty. Any worn pins are considered a usual wear issue therefore not warrantable as a manufacturing issue. The tightening of loose fittings is to be considered a maintenance issue, therefore any hydraulic leaks due to a loose fitting is not covered under warranty. Low or contaminated fluids, due to other than visible leaks are not covered under warranty.

No other warranty, express or implied (including, but not limited to warranties of merchantability or fitness for a particular purpose) has been made or exists. Without limiting, the foregoing, **EXCEPT AS OTHERWISE PROVIDED HEREIN, THE COMPANY: (1) UNDERTAKES NO RESPONSIBILITY FOR THE QUALITY OR PERFORMANCE OF THE GOODS; (2) ASSUMES NO RESPONSIBILITY THAT THE GOODS WILL BE FIT FOR ANY PARTICULAR APPLICATION.**

### WARRANTY PROCEDURES

#### PARTS & LABOR

1. Warranty work or claims will be made by authorized PALFINGER Liftgate Distributors or Service Centers.
2. Warranty work performed per the flat rate schedule will not need authorization. If the problem cannot be solved or flat rate labor is not listed, contact PALFINGER Liftgates for assistance.
3. Parts or materials sent out for warranty repair purpose will be invoiced and a credit will be issued upon return of defective parts. Parts used for inventory, will be replaced. Return Merchandise Authorization number (R.M.A.), serial number and manufactured date must be included for parts which are required to be returned.
4. All claims shall be paid according to PALFINGER's flat rate schedule.
5. PALFINGER Liftgates will pay the ground freight for replacement parts under warranty. Special shipping charges such as overnight and freight for returned parts will be the responsibility of the customer.
6. Only PALFINGER Liftgates O.E.M. parts will be warranted.

Warranty and Technical assistance is available from PALFINGER's toll free customer service lines from 7:00 a.m. to 5:00 p.m. PST. 1-888-774-5844 Extension 13 and 19.

All warranty claims must be received within **30 days** of repair or replacement. Including the following required information:

1. Liftgate model number
2. Liftgate serial number
3. Description of problem
4. Itemized bill of repair with break down of number of hours to perform warranty work and labor charges per repair
5. Parts used for repair with PALFINGER's part number
6. R.M.A. number
7. Contact at PALFINGER Liftgates (if applicable)

### ORDERING SPARE PARTS, REPAIRS

TYPE OF WARRANTY: PARTS REPLACEMENT ONLY

TERM OF WARRANTY: 1 YEAR FROM DATE OF PURCHASE

### SPARE PARTS:

In order to guarantee quick delivery, please be sure to include the following when placing orders:

1. Liftgate model and serial number
2. Designation and number of the part in accordance with the spare parts list
3. Designation and number marked on the individual component (if applicable)

**ORDERING SPARE PARTS:**

1. For single order \$50.00 minimum in parts.
2. All parts going parcel post will be shipped by ground, freight free, when total parts order exceeds \$1500.00
3. Call parts department toll free 1-888-774-5844 extensions 97 and 15 or fax 562-924-1046.
4. Next day air shipments must be received by 2:30 p.m. (Pacific Standard Time)

**RETURN OF SPARE PARTS:**

1. To receive credit on returned parts, the original purchase date must be within 6 months.
2. Parts must be received in *new condition*. Any part received not in new condition will be subject to inspection and possible refusal if part cannot be brought back to new condition. The cost of rework will be deducted from credit amount.
3. All parts being returned must have *R.M.A.* (Return Merchandise Authorization) number, copy of original invoice, and a detailed packing list of returned parts. All returned parts are subject to a 15% restocking charge.
4. R.M.A. numbers will be issued by parts department, and are valid for 30 days. All returned R.M.A. parts must be returned to PALFINGER Liftgates by prepaid freight or by call tag authorized by PALFINGER.

*All PALFINGER Liftgates parts are covered for one year from date of purchase against defects in material and workmanship.*

**PALFINGER LIFTGATES PARTS RETURN REQUEST:**

For quality control purposes and to be able to receive credit from our vendors, PALFINGER requires the return of some types of parts for credit to be given. Here are some examples but not limited to:

Hydraulic cylinders  
Structural components  
Pump and motor assemblies  
PC boards

If requested parts are not returned, no credit is given.

**REPAIRS:**

Parts sent to us to repair must be accompanied by a letter giving details and a scope of repairs required.



**HEWS COMPANY, LLC**  
 190 RUMERY STREET  
 SOUTH PORTLAND ME 04106  
 PHONE: (207) 767-2136  
 FAX: (207) 767-5381

ATTN:TERRY DEMERCHANT  
 MAINE DEPT OF TRANS-AUGUSTA  
 STATE HOUSE STATION 26  
 105 CAPITAL STREET  
 AUGUSTA ME 04333-0026

Quote Date: 05/03/17  
 Order #: U70651  
 Sales Rep: ROBERT HEWS  
 Customer #: 13246  
 Telephone #: 207-624-3132  
 Fax #: 207-287-8757

RFQ# 17D 17040500000000000614  
 BID DUE: 5/5/2017 AT 2:00PM  
 OPTION #2

1 - STEP SYSTEM (TRA3000)  
 3 rung design, spaced at 12" apart  
 Pull Out & Flip Down  
 In Use Dimensions: Length: 28", Out from truck: 14"  
 Stowed Dimensions: Length: 28-1/2", Distance from bottom of truck: 15"  
 Step Width: 14.5"  
 Grip Strut Style Treads  
 Ladder Retention Mechanism For Safe Storage  
 Capacity: 400 lbs

NOT INSTALLED, FOB, AUGUSTA, ME \$255.00 ea

OPTION:  
 1. INSTALL ON PLATFORM BODY ADD: \$85.00  
 RIGHT REAR CORNER

SALESPERSON: BOB HEWS / DAVE GAIN DELIVERY TIME: 50 TO 60 DAYS

VIN: TBD FLEET ID:  
 MAKE/MODEL: FORD F350 YEAR: 2017  
 TRANS: AUTOMATIC ENGINE: GAS  
 GVW: 14,000 CA: 60"

**Please sign order  
 and return 1 copy**

TERMS:  
**N30**

Sub-Total 255.00  
 F.E.T. 0.00  
 Sales Tax 0.00

Signature \_\_\_\_\_ Date \_\_\_\_\_

**Total 255.00**



Made to order. Made to last.

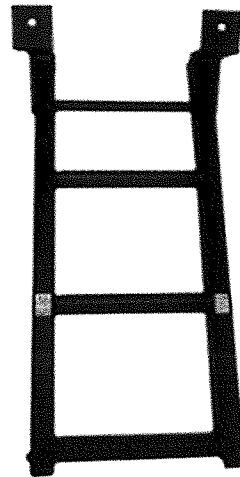

## Product Description

Provides an easy-to-use, stable, and safe means for drivers to enter and exit trucks and trailers.

Provides easy access to flatbeds for cargo securement inspections. Easy to install: simply bolt on!

The treads have a special Sure-Grip surface to provide maximum traction. Comes complete with durable, black powder coat finish, ready to mount. Now with a LIFETIME WARRANTY on materials and workmanship. This product is Manufactured in accordance with ISO 9001 Standards.

### In Use Dimensions

- Length: 28"
- Out from truck: 14"

### Stowed Dimensions

- Length: 28-1/2"
- Distance from bottom of truck/trailer: 15"



**HEWS COMPANY, LLC**  
 190 RUMERY STREET  
 SOUTH PORTLAND ME 04106  
 PHONE: (207) 767-2136  
 FAX: (207) 767-5381

ATTN:TERRY DEMERCHANT  
 MAINE DEPT OF TRANS-AUGUSTA  
 STATE HOUSE STATION 26  
 105 CAPITAL STREET  
 AUGUSTA ME 04333-0026

Quote Date: 05/03/17  
 Order #: U70652  
 Sales Rep: ROBERT HEWS  
 Customer #: 13246  
 Telephone #: 207-624-3132  
 Fax #: 207-287-8757

=====  
 RFQ# 17D 17040500000000000614  
 BID DUE: 5/5/2017 AT 2:00PM  
 OPTION #3

1 - READING SWING GATE SYSTEM IN LIEU OF STANDARD REARS  
 Includes Heavy Duty Bolt-on Heavy Duty Corner Posts.

NOT INSTALLED, FOB, AUGUSTA, ME

\$465.00 ea

OPTION:

1. INSTALL SWING REAR RACKS AND FIXED  
 REAR CORNER POST.

ADD: \$100.00

SALESPERSON: BOB HEWS / DAVE GAIN

DELIVERY TIME: 50 TO 60 DAYS

=====  
 VIN: TBD FLEET ID:  
 MAKE/MODEL: FORD F350 YEAR: 2017  
 TRANS: AUTOMATIC ENGINE: GAS  
 GVW: 14,000 CA: 60"

**Please sign order  
 and return 1 copy**

TERMS:  
**N30**

Sub-Total 465.00  
 F.E.T. 0.00  
 Sales Tax 0.00

\_\_\_\_\_  
 Signature Date

**Total 465.00**



# OPTIONAL EQUIPMENT

## Rear Swing-out Racks

Permits rear racks to open freely without lifting them out of the stake pockets.

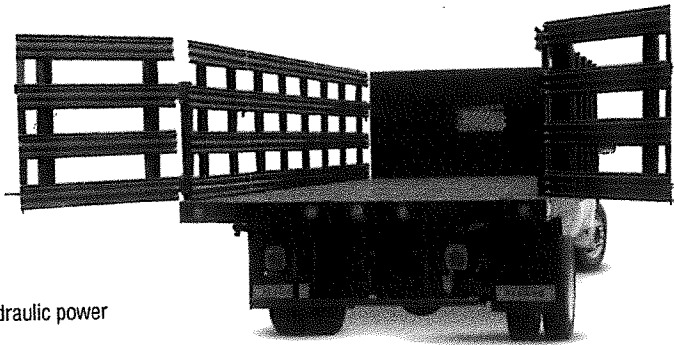

## Subframe Hoist

- Double-acting (power-up/power-down) 12-volt electric hydraulic power unit for ease of operation
- Hydraulic pump, plumbing and wiring included with complete hoist package
- Large diameter cylinder for increased hydraulic pressure and maximum lifting capacity
- Concentrated seal and cylinder packing for leak-free operation
- Low mount subframe easily attaches to chassis truck frame
- Black powder coat finish

## Available on Special Order:

- Extra crossmembers (12" centers)

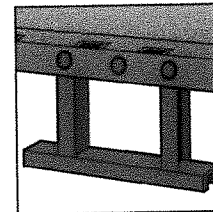

ICC bumper

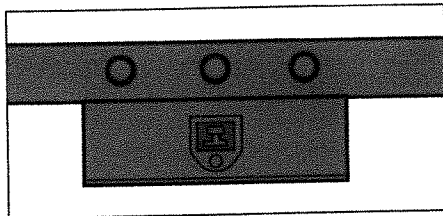

## "Possum Belly" Compartment

Storage tunnel under platform and between long sills with hinged access door

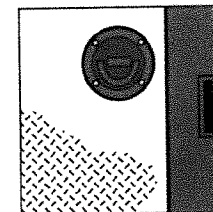

Heavy-duty recessed tie-down rings

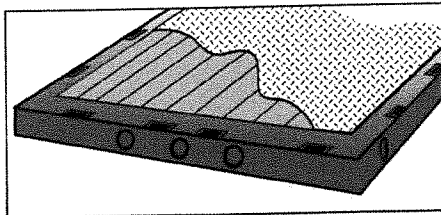

## Deck Overlay

3/16" deck plate steel over wooden floor

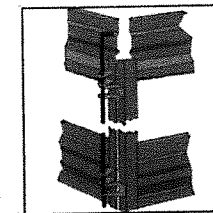

Lift up swing-out hinges



PROVIDES PEACE OF MIND DOWN THE ROAD

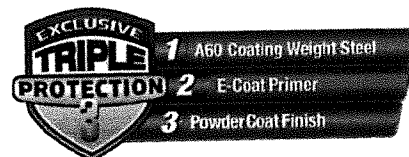



## Hoist Specifications

Reading's Hoist was designed for strength, durability and ease of serviceability. All hinge and wear points include grease fittings for lubrication. The hoist is sub-frame mounted and is installed in accordance with all O.E.M. chassis guidelines. The hoist has a NTEA Class 30 rating and offers lifting capacities ranging from 8 - 13 ton (based on hinge point and body overhang). The hoist and it's sub-frame are finished in powder-coat for corrosion protection and are backed by Reading's Exclusive 3 Year Limited Warranty.

- Reading double acting, electric hydraulic scissor hoist with single stage cylinder
- NTEA Performance Class C Rating – operating lifting capacity of 8 -13 tons
- 2 inch cylinder rod diameter
- Cylinder bore 5-1/2 inches
- Cylinder stroke 14 inches
- Maximum operating pressure 3500 PSI
- Electric/Hydraulic Power Unit Assembly with self-contained hydraulic reservoir
- Lift angle: 50 degrees
- Black powder coat finish
- All weather pump and motor cover
- In cab tethered hand held control to raise and lower dump body

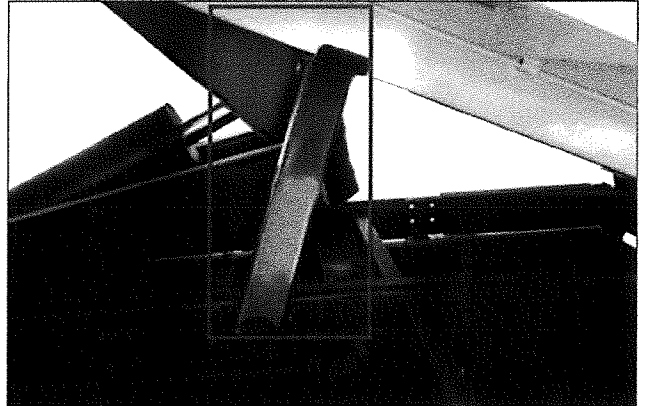

Body prop to secure body when in raised position

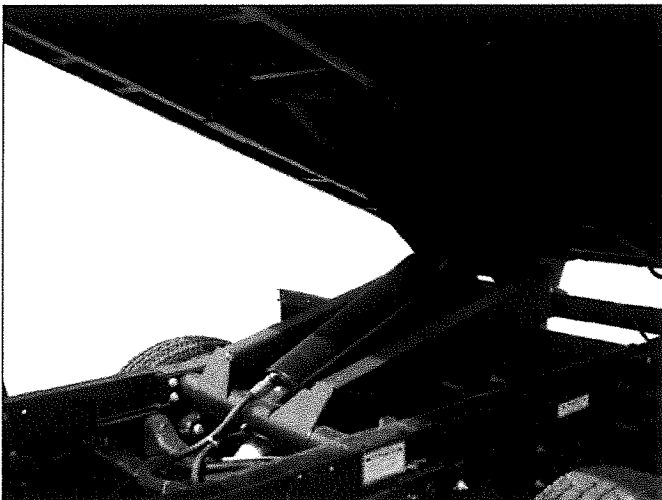

Hard chrome piston rod, lubricated bearing points, and full length subframe