

NEW

State of Maine



Master Agreement

Effective Date: 11/01/18

Expiration Date: 10/31/19

Master Agreement Description: Master Agreement for 14' Platform Rack Body & Accessories

Buyer Information

Donny Crockett	207-624-7336 ext.	Donny.Crockett@maine.gov
----------------	-------------------	--------------------------

Issuer Information

Jessica Norton	207-624-8226 ext.	Jessica.h.norton@MAINE.GOV
----------------	-------------------	----------------------------

Requestor Information

Jessica Norton	207-624-8226 ext.	Jessica.h.norton@MAINE.GOV
----------------	-------------------	----------------------------

Authorized Departments

17D	MOTOR TRANSPORT
17A	TRANSPORTATION

Vendor Information

Vendor Line #: 1

Vendor ID

VS0000000040

Vendor Name

Hews Company, LLC

Alias/DBA

Vendor Address Information

190 Rumery Street

South Portland, ME 04106

US

Vendor Contact Information

Katy Hews

207-767-2136 ext. 121

khews@hewSCO.com

Payment Discount Terms

Discount 1:	0.0000 %	0 Days
Discount 2:	%	0 Days
Discount 3:	%	0 Days
Discount 4:	%	0 Days

Commodity Information

Vendor Line #: 1

Vendor Name: Hews Company, LLC

Commodity Line #: 1

Commodity Code: 06500

Commodity Description: 14' Platform Rack Body

Commodity Specifications: As per the specifications attached made part of this MA.

Commodity Extended Description: 14' Platform Rack Body and accessories/options

Quantity 0.00000	UOM	Unit Price \$0.00
Delivery Days 120	Free on Board FOB Dest, Freight Prepaid	
Contract Amount \$0.00	Service Start Date	Service End Date
Catalog Name Hews 14 Foot	Discount 0.0000 %	
	Discount Start Date 11/01/18	Discount End Date 10/31/19

**STATE OF MAINE
DEPARTMENT OF ADMINISTRATIVE AND FINANCIAL SERVICES
BUREAU OF BUSINESS MANAGEMENT
DIVISION OF PROCUREMENT SERVICES**

RFQ # 17D18082300000000000063

14 FOOT PLATFORM BODY

- **Quotations/Responses Due: 9/20/2018** not later than 4:00 p.m. local time.

Note: All questions and responses must be provided via the State of Maine’s e-Procurement system: AdvantageME / Vendor Self Service (VSS).

General Instructions on Bidder Questions

It is the responsibility of each Bidder to examine the entire RFQ and to seek clarification by submitting questions through the Q & A List tab on the Solicitation page. Any answers to questions will appear there as well. It is the vendor's responsibility to log in to view all questions and answers posted. Additional information obtained any other way will not be valid.

In the event that you must contact us for any other reasons than the Q & A previously mentioned, only the Buyer listed on the Solicitation page may be contacted from the time this RFQ is issued until award notification is made. No other person/State employee is empowered to make binding statements regarding this RFQ. Violation of this provision may lead to disqualification from the bidding process, at the State’s discretion.

Summary

For this competitive Request for Quotations (RFQ) process, the State of Maine Division of Procurement Services (“Division”) is acting on behalf of MaineDOT (“Requesting Department”). The Division and the Requesting Department seek quotations (also referred to as “bids” or “responses” herein) to provide the goods/services listed above. This document provides instructions and descriptions of requirements for this competitive process.

RFQ REQUIREMENTS

1. Description of Requirements

The following is a description of the goods and/or services sought by the State of Maine under this RFQ.

- Please see **Appendix B**

2. Bid Contents Requirements

In addition to the cost, delivery, and other information required in VSS, all bids should contain the following information as attachments, in the Appendices listed below:

- **Appendix A: Bid Cover Page and Debarment Form (Pages 11 & 12 of this document)**
- **Appendix D: Maine Business and Economic Impact Consideration Form (Page 22 of this document)**
- **Appendix E: Municipality Political Subdivision and School District Participation Certification (Page 23 of this document)**
- **Appendix F: Certifications (Pages 24 thru 26 of this document)**
- **Technical & Cost Response (Pages 13 thru 20 of this document)**
- **Product Data/Information Sheets**
- **Warranty Information**

3. Master Agreement Term

In addition to any mutually agreed upon delivery dates for purchases of goods, the contract resulting from this RFQ will have a term, or “Period of Performance”, during which the contract is considered to be in effect. The anticipated contract term is defined in the table below. Please note that the dates below are estimated and may be adjusted as necessary in order to comply with all procedural requirements associated with this RFQ and the contracting process. The actual contract start date will be established by the completed and approved contract.

Contract Renewal: Following the initial term of the contract, the Division may opt to renew the contract for **three** renewal periods of one year each, subject to continued availability of funding and satisfactory delivery/performance.

The term of the anticipated contract, resulting from this RFQ, is defined as follows:

Period	Start Date	End Date
Initial Period of Performance	10/1/2018	9/30/2019
Renewal Period #1	10/1/2019	9/30/2020
Renewal Period #2	10/1/2020	9/30/2021

4. Submitting a Quotation

- a. **Quotations Due:** Quotations must be received no later than 4:00 p.m. Eastern Standard Time (EST), on the date listed in VSS. Quotations received after the 4:00 p.m. deadline will not be accepted.
- b. **Submission Instructions:** Bidders must submit their bids in the State of Maine’s electronic procurement system: Advantage “Vendor Self Service” (VSS). More information on this system can be found at the following internet link: <http://www.maine.gov/purchases/venbid/rfq.shtml>.
- c. **Multiple Quotations:** Unless specifically prohibited in Section 1 of this RFQ, Bidders are permitted to submit multiple quotations for this RFQ, offering alternative items or pricing for the State of Maine to consider in its best value determination.
- d. **Withdrawal of a Quotation:** Bidders are permitted to withdraw their own quotations up until the due date and time for receipt of quotations. To do so, a Bidder must enter the VSS system (as referenced above), identify and open their submitted quotation located in the Solicitation Responses tab, and click the “Withdraw” button found at the bottom of the screen. Quotations cannot be withdrawn after the due date and time for receipt of quotations.
- e. **Attachments:** Any attachments provided with the Advantage VSS bid submission must be in MS Word, MS Excel, or Adobe (.pdf) format, unless otherwise specified in Section 1 of this RFQ. Vendors are encouraged to submit supporting documentation that aid the requesting department in understanding how the bid conforms to the requirements. **The VSS attachment file size limit is 2Mb.** Please contact the buyer for this RFQ if you must submit attachment files larger than this.
- f. **Vendor specifications:** Unless otherwise stated in this RFQ document, limited specification information will be required upon submission of a bid in response to this RFQ. However, a Bidder’s response should include an affirmative statement that their bid complies with all requirements of this RFQ, unless the Bidder specifically addresses how its bid differs from the specifications, and why the differences should be deemed acceptable by the State.

5. **General Instructions**

- a. The Bidder must submit a cost quotation response that covers the goods and term of the contract, including any optional renewal.
- b. The cost quotation shall include the costs necessary for the Bidder to fully comply with the contract terms and conditions and RFQ requirements.
- c. Failure to provide the requested information may result in the exclusion of the quotation from consideration, at the discretion of the Division.
- d. No costs related to the preparation of the quotation for this RFQ or to the negotiation of the contract with the Department may be included in the quotation.
- e. The State is exempt from the payment of Federal, State and local Taxes on articles not for resale. Please provide quotations that do not include these taxes. Upon application, an exemption certificate can be furnished by the State at the point of contract finalization.

6. **Quotation Evaluation and Selection**

Evaluation of the submitted quotations shall be accomplished as detailed below:

- a. State of Maine RFQ documents are evaluated on a **Best Value** basis. The term “Best Value” may take into consideration the qualities of the goods or services to be supplied, their conformity with the specifications listed in the RFQ, the purposes for which they are

required, the date of delivery, and the best interest of the State. Once the goods or services have been determined to conform to the specifications then the Division will make its award decision based on the lowest price among the Bidders. Delivery days can be a factor in awarding.

- b. The State reserves the right to not make an award to the lowest price bidder when that bidder has had documented poor performance and/or a contract terminated or not renewed within the last five years.
- c. At the discretion of the Division, if a Bidder’s submission is deemed to not conform to the specifications listed in the RFQ, or otherwise not conform to the requirements of the RFQ, then that Bidder’s submission may not be considered for contract award.
- d. In the event that no Bidder submission conforms to the specifications of this RFQ, then the Division may choose not to make any award. Alternatively, the Division may make an award to the Best Value Bidder whose specifications *most closely meet* the specifications of this RFQ. For example, if there are five specification requirements, and two responses are received with one Bidder meeting four requirements, and one bidder meeting three requirements, then the Division, at its discretion, may make a contract award to the Bidder meeting four requirements.
- e. If the specifications provided with this RFQ are of a technical nature, then the Division’s RFQ Coordinator, at his or her discretion, may seek to use an evaluation team comprised of subject matter experts, end-users from the Requesting Department, or other State Department representatives. In such a case, the evaluation team will judge the merits of the quotations received in accordance with the best value criteria defined in the RFQ.

f. Maine Business and Economic Impact Consideration

Using **Appendix D** (Maine Business and Economic Impact Consideration Form), the Bidder (Bidder identified on the “Bid Cover Page” - **Appendix A**) is required to describe the Bidder’s investment in the State of Maine as reported on the most recently completed IRS form W-2. Consideration of this information in making contract award decisions is required in accordance with Executive Order 2017-003, which states “Evaluators of competitive bids for goods and services shall give consideration to the investment in the State by business enterprises as a best-value criterion.” The State reserves the right to verify this information at any time during the evaluation process or after.

The Maine Business and Economic Impact Consideration will allow up to a 10% reduction in a Bidder’s submitted price for comparison purposes when determining award. The exact percentage will be determined using the information provided by Bidders on their submitted Maine Business and Economic Impact Consideration Form (**Appendix D**) compared to the percentage breakdowns below:

Maine Business Analysis	Percentage
Average Percentage of Maine Business Impact - 1 to 74%	2%
Average Percentage of Maine Business Impact - 75 to 100%	4%

Maine Economic Impact	Percentage
Sum of Maine Economic Analysis - \$1 to \$1,000,000	2%
Sum of Maine Economic Analysis - \$1,000,001 to \$10,000,000	4%
Sum of Maine Economic Analysis - over \$10,000,000	6%

The percentages from both Maine Business Analysis and Maine Economic Impact will be combined for a Bidder's total percentage reduction in price. For example, if a Bidder has a "Average Percentage of Maine Business Impact - 1 to 74%" in Maine Business Analysis and a "Sum of Maine Economic Analysis - \$1,000,001 to \$10,000,000" in Maine Economic Impact, their total percentage reduction for price comparison would be 6% (2% + 4%).

7. Negotiations

- a. No Best and Final Offers: The State of Maine will not seek a best and final offer (BAFO) from any Bidder in this procurement process. All Bidders are expected to provide their Best Value pricing with the submission of their quotation.
- b. The Division reserves the right to negotiate with the successful Bidder to finalize a contract at the same rate or cost of goods and services as presented in the selected quotation. Such negotiations may not significantly vary the content, nature or requirements of the quotation or the RFQ to an extent that may affect the price of goods or services requested. The Division reserves the right to terminate contract negotiations with a selected Bidder who submits a proposed contract significantly different from the quotation submitted in response to the RFQ.
- c. In the event that an acceptable contract cannot be negotiated with the highest ranked Bidder, the Division may withdraw its award and negotiate with the next-highest ranked Bidder, and so on, until an acceptable contract has been finalized. Alternatively, the Division may cancel the RFQ, at its sole discretion.

TERMS AND CONDITIONS FOR RFQ AND CONTRACT

PART I GENERAL INFORMATION ON RFQs

A. Purpose and Background

The State of Maine (“State”) Department of Administrative and Financial Services (“Department”), Bureau of Business Management (“Bureau”), Division of Procurement Services (“Division”) acts as the purchasing agent on behalf of all Executive Departments and other agencies within State Government. For this competitive Request for Quotations (RFQ) process, the Division is acting on behalf of the Requesting Department listed on the cover page. The Division and the Requesting Department seek quotations (also referred to as “bids” or “responses” herein) to provide the goods/services as defined above in Section 1 of this document. This document provides instructions for submitting quotations, the procedure and criteria by which the Bidder(s) will be selected, and the contractual terms which will govern the relationship between the State and the awarded Bidder(s). Following Bidder selection and upon reaching a mutual agreement, the State and the selected Bidder will enter into a contract – taking the form of a State of Maine Master Agreement or Buyer Purchase Order (all generally referred to as “contract” herein), as applicable.

B. General Provisions

1. Issuance of this RFQ does not commit the Division or the Requesting Department to issue an award or to pay expenses incurred by a Bidder in the preparation of a response to this RFQ. This includes attendance at personal interviews or other meetings and software or system demonstrations, where applicable.
2. All responses to this RFQ should adhere to the instructions and format requirements outlined in this RFQ and all written supplements and amendments (such as the Division’s answers to the Bidders’ questions submitted through the VSS), as issued by the Division. Responses are to follow the format and respond to all questions and instructions specified above in the “Submitting a Quotation” section of this RFQ.
3. Bidders shall take careful note that in evaluating a quotation submitted in response to this RFQ, the Department may consider materials provided in the quotation, information obtained through interviews/presentations (if any), and internal information of previous contract history between the Division and the Bidder (if any). The Division also reserves the right to consider other reliable references and publicly available information available in evaluating a Bidder’s experience and capabilities, if needed. All responses to this RFQ shall be considered to be authorized to legally bind the Bidder, and if selected for award, shall contain or be considered to contain a statement that the quotation and the pricing contained therein will remain valid and binding for a period of at least 180 days from the date and time of the bid opening.
4. The RFQ and the selected Bidder’s quotation, including all appendices or attachments, may be incorporated in the final contract.
5. Following announcement of an award decision, all submissions in response to this RFQ will be considered public records available for public inspection pursuant to the State of Maine Freedom of Access Act (FOAA) (1 M.R.S. §§ 401 et seq.).
<http://www.mainelegislature.org/legis/statutes/1/title1sec401.html>
6. The Division, at its sole discretion, reserves the right to recognize and waive minor informalities and irregularities found in quotations received in response to this RFQ.

7. The Division reserves the right to authorize other State Departments to use the contract(s) resulting from this RFQ, if it is deemed to be beneficial for the State to do so.
8. All applicable laws, whether or not herein contained, shall be included by this reference. It shall be Bidder's responsibility to determine the applicability and requirements of any such laws and to abide by them.

C. Eligibility to Submit Bids

Public agencies, private for-profit companies, and non-profit companies and institutions are invited to submit bids in response to State of Maine Requests for Quotations.

D. Delivery Terms

For the purchase of goods, the Division and selected Bidder will decide upon a delivery date in accordance with the State's requirements and the terms offered in the Bidder's quotation. *Unless stated otherwise in Section 1 of this RFQ, all deliveries are expected with shipping terms of "Free on Board (FOB) – Destination"*. The State intends for this to mean that all goods shall be priced in the bid response to include shipping charges, if any, to the State's desired location. The "FOB – Destination" shipping term is also intended to mean that the State shall not bear any responsibility for the goods in question until the State takes possession of them at the destination point of delivery.

E. Alternate Bids and Approved Equals

When, in bid forms and specifications, an article or material is identified by using a trade name and catalog number of a manufacturer or vendor, the term "or approved equal," if not inserted with the identification, is implied. Any Bidder that seeks to propose an alternate item from what is specified in this RFQ should refer to State of Maine Statute 5 MRSA §1825-B, for "Bids, awards and contracts", found here: <http://www.mainelegislature.org/legis/statutes/5/title5sec1825-B.html>

F. Appeal of Contract Awards

Any person aggrieved by the award decision that results from this RFQ may appeal the decision to the Director of the Bureau of General Services in the manner prescribed in 5 MRSA § 1825-E and 18-554 Code of Maine Rules, Chapter 120 (found here: <http://www.maine.gov/purchases/policies/120.shtml>). The appeal must be in writing and filed with the Director of the Bureau of General Services, 9 State House Station, Augusta, Maine, 04333-0009 within 15 calendar days of receipt of notification of contract award.

If this RFQ results in the creation of a pre-qualified or pre-approved list of vendors, then the appeal procedures mentioned above are available upon the original determination of that vendor list, but not during subsequent competitive procedures involving only the pre-qualified or pre-approved list participants.

PART II CONTRACT ADMINISTRATION AND CONDITIONS

A. Contract Document

The successful Bidder will be required to execute a contract in the form of a State of Maine Buyer Purchase Order, Contract Agreement to Purchase Services or State of Maine Master Agreement.

The Standard Terms and Conditions used with the aforementioned contract types may be found on the Division of Procurement Services' website at the following link:

http://www.maine.gov/purchases/info/forms/BPO_General_Terms.doc

In the event that the State of Maine's Standard Terms and Conditions or RFQ provisions do not otherwise cover contractual scenarios that are specific to the goods or services being purchased under this RFQ, then the State is willing to consider a Bidder's standard terms and conditions. Consideration or use of a Bidder's standard terms and conditions shall only occur under the general agreement that in the event of a conflict, the State of Maine's Standard Terms and Conditions and RFQ provisions shall take precedence.

Other forms and contract documents commonly used by the State can be found on the Division of Procurement Services' website at the following link:

<http://www.maine.gov/purchases/info/forms.shtml>

B. Independent Capacity

In providing services and performing under the contract, the successful Bidder shall act independently and not as an agent of the State of Maine.

C. Payments and Other Provisions

The State anticipates paying the selected Bidder for goods and services received, on the basis of net 30 payment terms, upon the receipt of an accurate and acceptable invoice. An invoice will be considered accurate and acceptable if it contains a reference to the State of Maine contract number, contains correct pricing information relative to the contract, and provides any required supporting documents, as applicable, and any other specific and agreed-upon requirements listed within the contract that results from this RFQ.

The State of Maine reserves the right to pay for goods purchased through this solicitation by any of several available means, which include but may not be limited to check, EFT, and/or procurement card. Bidders are advised that state statute precludes sellers from imposing a surcharge on credit or debit card purchases (text follows):

“9-A MRS §8-303 (2): A seller in a sales transaction may not impose a surcharge on a cardholder who elects to use a credit card or debit card in lieu of payment by cash, check or similar means.”

1.0 MaineDOT GENERAL REQUIREMENTS

The following requirements and conditions shall be considered an essential part of the specifications and proposal.

1. Purchase of the 14 FOOT PLATFORM BODY is subject to a Financial Assistance Agreement between the Department and the U.S. Department of Transportation.
2. All equipment bids must conform to the final approved specifications and all Federal and State laws, regulations and standards. Where these specifications and Federal and/or State laws conflict, the requirements of the Federal and/or State laws shall prevail.

APPLICABLE REGULATIONS: SEE CERTIFICATIONS REQUIRED

3. Equipment and component parts must be of the highest quality and workmanship available in the various trades and of substantial, durable, and safe construction. In all cases materials and construction of the equipment must be furnished as specified but when brand names are used in the specifications, the term “approved equal” is implied and will be considered.
4. No advantage shall be taken by the equipment manufacturer or bidder in the omission of parts or details required to make the equipment complete and ready for service even though such parts or details may not be mentioned in these specifications. All units or parts not herein contained or specified shall be manufacturer’s standard. All parts shall be new. In no case will used, reconditioned, or obsolete parts be accepted. Insofar as possible, parts and equipment in any one vehicle shall be a duplicate in manufacture, design and construction and shall be interchangeable with parts and equipment in any other equipment in the proposal.
5. The bidder shall furnish descriptive literature for the equipment being bid. This material shall be mailed along with completed documents (certifications).
6. The price quoted in any proposal shall include all items of labor, material, tools, equipment, delivery and other costs necessary to fully complete the delivery of equipment pursuant to these specifications.
7. The Division of Procurement Services/MaineDOT reserves the right to accept any quote or reject any or all quotes for any reason, including, but not limited to, the following reasons:

Quotes which take exception to the specifications without approval pursuant to (Section 3.9 Specification Certification) of the Invitation to Quote.

High lifecycle operating and maintenance costs based on evaluation of equipment performance, warranty data, and local availability of service and parts pursuant to (Section 3.4 Certification Vehicle Performance & Warranty Data).

Quotes considered not responsive due to lack of required certificates and information required in (Section 3.0 Certifications).

The Division of Procurement Services/MaineDOT reserves the right to award the Contract to the lowest responsible bidder, best value consideration, and however is in the best interest of the State of Maine.

The Division of Procurement Services and the Department reserve the right to evaluate specifications and alternates and determine equivalency.

8. Bidder shall submit the earliest possible delivery date with this Quote.
Earlier delivery dates will be given consideration during the quote selection process. In addition, penalties may be assessed for late delivery pursuant to Section F of Appendix G.

Appendix A

**STATE OF MAINE
DEPARTMENT OF ADMINISTRATIVE AND FINANCIAL SERVICES
DIVISION OF PROCUREMENT SERVICES**

BID COVER PAGE and DEBARMENT FORM

Bidder's Organization Name:		
Chief Executive - Name/Title:		
Tel:	Fax:	E-mail:
Headquarters Street Address:		
Headquarters City/State/Zip:		
<i>(provide information requested below if different from above)</i>		
Lead Point of Contact for Bid - Name/Title:		
Tel:	Fax:	E-mail:
Street Address:		
City/State/Zip:		

By signing below Bidder affirms:

- Their bid complies with all requirements of this RFQ;
- This bid and the pricing structure contained herein will remain firm for a period of 180 days from the date and time of the bid opening;
- That no personnel currently employed by the Department or any other State agency participated, either directly or indirectly, in any activities relating to the preparation of the Bidder's proposal;
- That no attempt has been made or will be made by the Bidder to induce any other person or firm to submit or not to submit a proposal; and
- The undersigned is authorized to enter into contractual obligations on behalf of the above-named organization.

Name:	Title:
Authorized Signature:	Date:

Debarment, Performance, and Non-Collusion Certification

By signing this document, I certify to the best of my knowledge and belief that the aforementioned organization, its principals, and any subcontractors named in this proposal:

- a. Are not presently debarred, suspended, proposed for debarment, and declared ineligible or voluntarily excluded from bidding or working on contracts issued by any governmental agency.*
- b. Have not within three years of submitting the proposal for this contract been convicted of or had a civil judgment rendered against them for:

 - i. fraud or a criminal offense in connection with obtaining, attempting to obtain, or performing a federal, state or local government transaction or contract.*
 - ii. violating Federal or State antitrust statutes or committing embezzlement, theft, forgery, bribery, falsification or destruction of records, making false statements, or receiving stolen property;*
 - iii. are not presently indicted for or otherwise criminally or civilly charged by a governmental entity (Federal, State or Local) with commission of any of the offenses enumerated in paragraph (b) of this certification; and*
 - iv. have not within a three (3) year period preceding this proposal had one or more federal, state or local government transactions terminated for cause or default.**
- c. Have not entered into a prior understanding, agreement, or connection with any corporation, firm, or person submitting a response for the same materials, supplies, equipment, or services and this proposal is in all respects fair and without collusion or fraud. The above mentioned entities understand and agree that collusive bidding is a violation of state and federal law and can result in fines, prison sentences, and civil damage awards.*

- Failure to provide this certification may result in the disqualification of the Bidder’s proposal, at the discretion of the Department.**

To the best of my knowledge all information provided in the enclosed proposal, both programmatic and financial, is complete and accurate at the time of submission.

Name:	Title:
Authorized Signature:	Date:

Appendix B

**STATE OF MAINE
DEPARTMENT OF ADMINISTRATIVE AND FINANCIAL SERVICES
DIVISION OF PROCUREMENT SERVICES**

DETAILED SPECIFICATIONS

RFQ # 17D18082300000000000063

14 FOOT PLATFORM BODY

INTENT

The purpose and intent of this specification is to describe an approximately 14' Platform Body with fixed bulkhead and removable stake sides. Specifications include four options to be priced separately.

- Option 1 - lift gate with a minimum of 1,600 lbs. capacity
- Option 2 - pull-down step that can be stored in place when not in use
- Option 3 - hinged Swing Gate Kit
- Option 4 - hydraulic body hoist with a minimum 6-ton capacity
- Installation cost

Bodies will be mounted on a latest model year Ford F-550 with 108" CA dimension, 19,500 lb. GVW rating, dual rear wheels, gas or diesel engine and automatic transmission. MaineDOT estimates three (3) units, however, the state reserves the right to order more or less as needed (depending on funding) for two (2) calendar years. Individual stake bodies may be purchased separately or with any combination of listed options. Individual options may be ordered to be installed on platform bodies already in MaineDOT service.

COMPLETENESS

The price quoted in any proposal submitted shall include all items of labor, materials, and other costs necessary to fully complete the manufacture and delivery of the platform/rack body pursuant to these specifications.

Any part or detail which makes the platform/rack body complete and ready for service shall not be omitted, even though such part is not mentioned in these specifications.

CONFORMITY

All parts not specified shall be manufacturer's best quality and shall conform in materials, design, or workmanship to the best practice known in the platform/rack body industry. All parts shall be new and in no case will used, reconditioned or obsolete parts be accepted. The parts on all platform/rack bodies provided by the manufacturer should be interchangeable.

INSTRUCTIONS FOR COMPLETING TECHNICAL SPECIFICATION SHEET

Please complete the checklist for technical specifications set forth below.

Electronically enter responses directly into the text-enabled fields next to each specification, including actual dimensions when applicable. Each Bidder must indicate whether it can meet the technical specifications by inserting an “X” next to each specification. The “X” will demonstrate that the Bidder’s offering meets the technical specification. If a Bidder cannot meet a technical specification, then the Bidder must give an explanation for each exception and for equipment that is not available or that will be dealer installed. All explanations must be provided in detail on separate pages along with the justification as to why the alternative equipment or deliverables will be as good as the equipment or deliverables described in the detailed specifications for desired items. A copy of the vendor specification proposal must be provided. Following these instructions is essential for proper bid evaluation.

If a Bidder fails to provide requested information or if information on a quote is found to be false or misleading, the quote will be rejected as unresponsive.

The award will be made on a best value basis to the vendor that either meets or most closely meets the specifications, while taking price and delivery into consideration.

The following abbreviations must be used:		<table border="1"> <tr> <td>X</td> <td>Standard or as specified</td> </tr> <tr> <td>N/A</td> <td>Not Available</td> </tr> <tr> <td>DI</td> <td>Dealer Installed</td> </tr> <tr> <td>AE</td> <td>Approved Equal</td> </tr> </table>			X	Standard or as specified	N/A	Not Available	DI	Dealer Installed	AE	Approved Equal
X	Standard or as specified											
N/A	Not Available											
DI	Dealer Installed											
AE	Approved Equal											
	2.0 CONSTRUCTION	Abbreviation	Actual Dimension	Notes								
2.1	End rails and side rails shall be a minimum 5 5/8” 12ga. high strength steel.											
2.2	Crossmembers shall be a minimum of 4-inch 11ga. high strength “C” channel.											
2.3	Crossmember spacing shall be a minimum of every twenty-four (24) inches.											
2.4	Gussets shall be front and rear rails along with every other crossmember.											
2.5	Long sills shall be a minimum of 4-inch 10ga. formed channel, and install with a											

	minimum of 34-inch spacing, minimum length shall be 116”.			
2.6	Flooring shall be 2-inch x 6-inch tongue and groove treated dense pine.			
2.7	Lights shall be LED and recessed mounted in shock resistant rubber grommets and loom protected wires.			
2.8	Stake pockets shall be 1.7-inch x 3.75 inch reinforced on 24-inch centers.			
2.9	Stake racks shall be a minimum of 40 inches high.			
2.10	Stakes shall be made from a minimum of 14ga. galvaneal steel.			
2.11	Slats shall be made from a minimum of 16ga. steel and roll formed.			
2.12	Attaching hardware shall be spring loaded, anti-rattle, heavy-duty hardware.			
2.13	Bulkhead shall be rectangular drop in 40 inches high and 96 inches wide with Hole Punched or Mesh center window.			
2.14	Bulkhead shall have minimum 12” reinforced Cab Plate to support accessories such as ladders and Emergency Lights – 12” footprint, flat on top.			
2.15	Bulkhead shall be welded in place to the front rub rail.			
2.16	Hitch shall use a 2½” square receiving opening.			
2.17	Hitch shall attach to the vehicle frame only.			
2.18	Hitch shall be a class V, rated up to 16,000 lbs. gross trailer weight, with 7-prong Round			

	pin trailer plug-in (See wire diagram). RV plugs will not be accepted.																																			
	<table border="1"> <thead> <tr> <th>Circuits</th> <th>Code #</th> <th>Marking</th> <th>Color Code</th> </tr> </thead> <tbody> <tr> <td>Ground</td> <td>1</td> <td>W</td> <td>White</td> </tr> <tr> <td>Clearance, Side Marker & Identification Lamps</td> <td>2</td> <td>BK</td> <td>Black</td> </tr> <tr> <td>Left Turn & Hazard Signal</td> <td>3</td> <td>Y</td> <td>Yellow</td> </tr> <tr> <td>Top Lamps & Anti-Lock Devices</td> <td>4</td> <td>R</td> <td>Red</td> </tr> <tr> <td>Right Turn Signal & Hazard Signal</td> <td>5</td> <td>G</td> <td>Green</td> </tr> <tr> <td>Tail, Rear Clearance Marker, & Plate Lamps</td> <td>6</td> <td>BR</td> <td>Brown</td> </tr> <tr> <td>Auxiliary Circuit</td> <td>7</td> <td>BL</td> <td>Blue</td> </tr> </tbody> </table>	Circuits	Code #	Marking	Color Code	Ground	1	W	White	Clearance, Side Marker & Identification Lamps	2	BK	Black	Left Turn & Hazard Signal	3	Y	Yellow	Top Lamps & Anti-Lock Devices	4	R	Red	Right Turn Signal & Hazard Signal	5	G	Green	Tail, Rear Clearance Marker, & Plate Lamps	6	BR	Brown	Auxiliary Circuit	7	BL	Blue			
Circuits	Code #	Marking	Color Code																																	
Ground	1	W	White																																	
Clearance, Side Marker & Identification Lamps	2	BK	Black																																	
Left Turn & Hazard Signal	3	Y	Yellow																																	
Top Lamps & Anti-Lock Devices	4	R	Red																																	
Right Turn Signal & Hazard Signal	5	G	Green																																	
Tail, Rear Clearance Marker, & Plate Lamps	6	BR	Brown																																	
Auxiliary Circuit	7	BL	Blue																																	
2.19	All components shall be E-Coat priming and corrosion protection.																																			
2.20	No wiring shall run through the stake pockets or an area where it can be pinched.																																			
2.21	All exterior trailer wiring shall be professionally installed and run in suitable weather resistant loom or conduit (professionally secured).																																			
2.22	All wire splicers/connectors (if applicable) shall be shrink tube barrel type or soldered and shall be sealed with weather-proof																																			

	automotive type shrink tubing, Scotch lock type (wire piercing) connectors are not acceptable in any application.			
	3.0 WARRANTY	Abbreviation	Actual Dimension	Notes
3.1	Manufacturer's standard warranty will apply.			
3.2	Terms and conditions of warranty must be provided with bid proposal.			
3.3	Manufacturer's warranty will start with the in-service date			
	4.0 GENERAL	Abbreviation	Actual Dimension	Notes
4.1	Bid price of body shall include mounting and all hardware to install on latest model Ford F550 with a 108-inch CA with dual wheels and delivery to MaineDOT Fleet Services in 66 Industrial Drive Augusta, ME 04330.			
4.2	Body and all components shall be black in color.			
4.3	Be it known that these specifications are a minimum and that bids will be evaluated based on price, warranty, manufacturer's performance data, delivery schedule, parts availability and other items deemed appropriate.			
4.4	Bidders are required to provide sufficient information with their bid such as manufacturer's brochures, specification sheet, etc. and to certify that they have service facilities in Maine, staffed with trained service technicians and stocked with repair parts for the equipment which is bid. Failure to provide this information may cause the bid to be rejected. Maine DOT reserves the right to reject any and all bids.			

4.5	Body must comply with the Department of Transportation Federal Motor Vehicle Safety Standards and Department of Labor Occupational Safety and Health Standards. Lighting equipment shall meet FMVSS # 108.			
4.6	Exceptions to specifications shall be listed on a separate paper and noted as exceptions and submitted with bid proposal. If exceptions are not listed as such it shall be considered that the vendor will comply with all specifications as listed.			
4.7	Backup alarm conforming to SAEJ 994 and OSHA requirements.			
	5.0 OPTION 1 - LIFT GATE	Abbreviation	Actual Dimension	Notes
5.1	Lift gate shall have a minimum capacity of 1,600 lbs.			
5.2	Lift gate shall be a minimum of 82 inches wide and 36 inches in height.			
5.3	Lift gate shall have cam activated power close.			
5.4	Lift gate shall include latch chains for transit.			
5.5	Lift gate shall have adjustable cylinder rod and clevis.			
5.6	Lift gate shall meet TMC electrical requirements.			
5.7	Power source for controlling the movement of the lift gate shall be a 12-volt self-contained hydraulic pump.			
5.8	Lift gate shall conform to fit rack body specifications above (non-dumping).			

5.9	Lift gate and components shall be black in color.			
	6.0 OPTION 2 - STEP	Abbreviation	Actual Dimension	Notes
6.1	Step shall be a pull out and flip down type with a minimum weight capacity of 350 lbs.			
6.2	Step shall have a minimum of two (2) rungs spaced no more than 12 inches apart.			
6.3	Step shall be a minimum of 11 inches in width.			
6.4	Step shall be stored within or under the body frame and have a mechanism to prevent losses of step while the vehicle is in motion.			
6.5	Step shall have a grip surface to provide for maximum traction.			
6.6	Ladder will be located at the right rear corner of the body facing the rear.			
	7.0 OPTION 3 – SWING GATE	Abbreviation	Actual Dimension	Notes
7.1	Swing Gate shall be galvanized steel posts and slats; rear swing gates with a heavy-duty bolt-on hinge assemblies.			
	8.0 OPTION 4 – BODY HYDRAULIC HOIST	Abbreviation	Actual Dimension	Notes
8.1	Hydraulic hoist shall have a minimum 6-ton capacity with integral safety prop.			
8.2	Power source for controlling the movement of the hydraulic hoist dump shall be a 12-volt self-contained hydraulic pump.			
8.3	Dump/Hoist assembly shall be of lowest type mounting available but should not preclude a sub frame if necessary.			
8.4	Body support, permanently attached, capable of being locked in place.			

8.5	Power up and down.			
8.6	Body longitudinal must not be cut to accommodate the hoist assembly.			
BODY PRICE (information required)				
Body Make & Model Number:				
\$ each				
9.0 INSTALLED OPTIONS (additional costs)				
	Installed Option	Model	Price	Notes
9.1	Lift Gate System		\$ each	
9.2	Step System		\$ each	
9.3	Swing Gate		\$ each	
9.4	Hydraulic Hoist		\$ each	
9.5	Labor to install complete body, bumper, hitch and delivered		\$	

Please include F.O.B. Destination shipping in your bid pricing!

Appendix C

**STATE OF MAINE
DEPARTMENT OF ADMINISTRATIVE AND FINANCIAL SERVICES
DIVISION OF PROCUREMENT SERVICES**

COST RESPONSE

RFQ # 17D18082300000000000063

14 FOOT PLATFORM BODY

All responses to this RFQ will require a cost quotation response, in a format selected by the State of Maine. That format is described below.

Please download this document to your desktop, fill out required sections (Appendix-A Bid Cover Page & Debarment Form, and Appendix D-Maine Business and Economic Impact Consideration), and attach to your response in VSS, along with requested documents. (Attachment maximum size is 2mb each!) For your electronic response in VSS, please put the total price of one body in the unit price field and enter the delivery days.

REQUESTED RETURNED DOCUMENTS:

- **Appendix A:** Bid Cover Page and Debarment Form (Pages 11 & 12 of this document)
- **Appendix D:** Maine Business and Economic Impact Consideration Form (Page 22 of this document)
- **Appendix E:** Municipality Political Subdivision and School District Participation Certification (Page 23 of this document)
- **Appendix F: Certifications** (Pages 24 thru 26 of this document)
- **Technical & Cost Response** (Pages 13 thru 20 of this document)
- **Product Data/Information Sheets**
- **Warranty Information**

Appendix D

**STATE OF MAINE
DEPARTMENT OF ADMINISTRATIVE AND FINANCIAL SERVICES
DIVISION OF PROCUREMENT SERVICES**

MAINE BUSINESS AND ECONOMIC IMPACT CONSIDERATION FORM

RFQ # 17D18082300000000000063

Maine Business and Economic Impact Consideration, as defined in this RFQ document, will ONLY be applied to bids that included the information requested below.

Instructions:

Maine Business Analysis

1. Fill in the total number of full time employees (FTE) your company employs companywide and how many of the FTE are Maine residents.
2. Fill in the total dollar value for companywide payroll and the total amount of payroll paid to Maine Residents.

Maine Economic Impact

1. Fill in the amount stated on your company’s most recent W-2 for:
 - Income taxes paid in Maine
 - Property taxes paid in Maine
2. Fill in the amount of wages paid to Maine residents.
3. Fill in the estimated dollar value your company paid to Maine Subcontractors in the last fiscal year.

Bidder's Organization Name:	
-----------------------------	--

MAINE BUSINESS ANALYSIS		
	Total	Maine Residents
Number of FTE Employees:		
Payroll:		

MAINE ECONOMIC IMPACT	
Income Taxes Paid (State):	
Property Taxes Paid (Local):	
Wages to Maine Residents:	
Payments to Maine Subcontractors Estimated:	

Appendix E

**STATE OF MAINE
DEPARTMENT OF ADMINISTRATIVE AND FINANCIAL SERVICES
DIVISION OF PROCUREMENT SERVICES**

**MUNICIPALITY POLITICAL SUBDIVISION and SCHOOL DISTRICT PARTICIPATION
CERTIFICATION**

RFQ # 17D18082300000000000063

14 FOOT PLATFORM BODY

The Division of Procurement Services is committed to providing purchasing opportunities for **municipalities, political subdivisions and school districts** in Maine by allowing them access, through our vendors, to our contract pricing. A bidder's willingness to extend contract pricing to these entities will be taken into consideration in making awards.

Will you accept orders from political subdivisions and school districts in Maine at the prices quoted?

Yes

Yes, with conditions as follows:

No

Name of Company:

Address:

Signature: _____

Date:

Appendix F

RFQ # 17D18082300000000000063

14 FOOT PLATFORM BODY

CERTIFICATIONS

1.0 NONCOLLUSION BIDDING CERTIFICATION

By submission of this Bid, each Bidder and each person signing on behalf of any Bidder certifies, and in the case of a joint bid, each party certifies as to its own organization, under penalty of perjury, that to the best of its knowledge and belief:

1. The prices in this Bid have been arrived at independently without collusion, consultation, communication or agreement, for the purpose of restricting competition as to any other matter relating to such prices with any other Bidder or with any other competitor;
2. Unless otherwise required by law, the prices which have been quoted in this Bid have not been knowingly disclosed by the Bidder and will not knowingly be disclosed by the Bidder prior to opening, directly or indirectly, to any other Bidder or to any competitor; and,
3. No attempt has been made or will be made by the Bidder to induce any other person, partnership or corporation to submit or not to submit a Bid for the purpose of restricting competition.

Dated

Printed name of Person Bidding

Authorized Signature

Title

2.0 EQUIPMENT PERFORMANCE AND WARRANTY DATA

The information provided on this form will be used in determining operating costs of the equipment. Bidder must complete this form and submitted with bid. Bids received without this information will be considered non-responsive to the bid.

1. EQUIPMENT:

2. **DESCRIBE THE PROCESS FOR THE SUBMISSION OF WARRANTY CLAIMS FOR REIMBURSEMENT OUTLINED AND SUBMITTED WITH THE BID. (written process to follow for reimbursement of warranty claims)**

3. **EQUIPMENT INFORMATION:**

YEAR: EQUIPMENT MAKE:

EQUIPMENT MODEL:

4. **MANUFACTURER’S RECOMMENDED PREVENTATIVE MAINTENANCE SCHEDULE MUST BE PROVIDED**

5. **BASIC EQUIPMENT WARRANTY DESCRIPTION**

6. **NAME/LOCATION OF REPAIR FACILITY(S)** (BOTH AUTHORIZED WARRANTY, PARTS & SERVICE PER REQUESTED LOCATION). It is desired that at least one facility is located within 75-mile radius each region headquarters: Scarborough, Augusta, Dixfield, Bangor and Presque Isle.

WARRANTY AND SERVICE FACILITIES

ADDRESS 1:
ADDRESS 2:
ADDRESS 3:
ADDRESS 4:
ADDRESS 5:

CONTACT NAME: TELEPHONE:

EQUIPMENT PARTS PROVIDER:

ADDRESS:

CONTACT NAME: TELEPHONE:

Attach written explanation describing the locations of the facilities, the contact name and number at each facility, the times the facilities will be available for use, the qualifications of the staff at the facilities and

how the vendor will provide warranty and service at these service facilities.

Bidder certifies that they have service facilities in Maine, staffed with trained service technicians and stocked with repair parts for the equipment which is bid.

This form must be reproduced and completed for any additional equipment warranty/facility information.

Dated

Signature

Print Name

Company Name

3.0 SPECIFICATION COMPLIANCE

The bidder hereby certifies that the equipment(s) being bid in response to this invitation meet or exceed these specifications and that where a deviation from the specifications exists, the bidder has obtained written approval of those exceptions prior to submitting this bid.

If a conflict exists between these specifications and Federal and/or State laws, the Federal and/or State laws shall prevail and the bidder must alert the purchaser to any such conflicts.

Dated

Printed name of Person Bidding

Authorized Signature

Title

Appendix G

RFQ # 17D18082300000000000063

14 FOOT PLATFORM BODY

MaineDOT TERMS AND CONDITIONS

A. AGREEMENT

The Vendor shall deliver the equipment ordered in accordance with this Agreement and governed by these Terms and Conditions.

B. INDEPENDENT CAPACITY

In providing the equipment under the Agreement, the Vendor shall act independently and not as an agent of the State of Maine.

C. STATUS REPORTS

Prior to the start of work, the Vendor shall furnish MaineDOT with a proposed progress schedule in MaineDOT's standard format. The Vendor will outline the various phases of work that will need to be completed in order to meet the schedule set forth by MaineDOT.

During equipment assembly, the successful bidder shall submit to MaineDOT's Fleet Representative, a Monthly Status Report of accomplishments from the preceding month. The progress report shall be used to keep team members and MaineDOT's Fleet Representative informed about project status and issues. Information will include:

- a. A written statement describing the work accomplished during the period and to date.
- b. An estimate of the percentage of work completed within the specified services.
- c. Any information needed from MaineDOT to complete the project and avoid delays.
- d. The successful bidder's action plan to remedy and address any non-conforming or unacceptable work submitted to Department.
- e. Document anticipated problems and possible solutions.

These progress reports shall be submitted to MaineDOT on a **monthly basis**. Failure to submit could result in non-payment of the invoice, or be considered as a default, and shall be recorded in the Vendor's Performance Evaluation. If work is temporarily delayed, the Vendor may suspend submittal of the monthly progress reports with written approval from MaineDOT. The Vendor shall be responsible for addressing any action that may be required to keep the project on schedule.

MaineDOT shall have a period of 15 business days after receipt of the submissions to complete the review and make any necessary comments. Following the review, the Vendor will make any revisions and corrections requested by MaineDOT.

D. PAYMENT AND OTHER PROVISIONS

MaineDOT anticipates paying the selected Vendor for goods and services received, on the basis of net 30 payment terms following acceptance of the equipment, the receipt of an acceptable title and required documents, and an accurate and acceptable invoice. An invoice will be considered accurate and acceptable if it contains the State of Maine Agreement number, correct pricing information relative to the Agreement, and provides any required supporting documents, as applicable, and any other specific and agreed-upon requirements listed within the Agreement.

MaineDOT reserves the right to pay for the equipment purchased by any of several available means, which include but may not be limited to check, EFT, and/or procurement card. Vendors are advised that state statute precludes sellers from imposing a surcharge on credit or debit card purchases (text follows):

“9-A MRSA §8-303 (2): A seller in a sales transaction may not impose a surcharge on a cardholder who elects to use a credit card or debit card in lieu of payment by cash, check or similar means.”

E. WARRANTY

For a period of one (1) year following equipment delivery and acceptance (the “Warranty period”), Vendor unconditionally warrants and guarantees that the equipment shall be free from defects in parts and workmanship. If MaineDOT discovers any defects during the Warranty period, the Vendor’s obligation will be to repair or replace the equipment or refund the purchase price, at MaineDOT’s sole option subject to the following requirements as applicable:

- Replacement will be with new equipment matching the specifications within this Agreement.
- Reimbursement will be for the total purchase price of the equipment including the cost of returning the equipment.
- All Repairs including the cost of transporting the equipment will be borne by the Vendor. All repairs will be warranted free from defects in parts and workmanship for a one year period following the repair.

The Vendor hereby assigns to MaineDOT the right to enforce all manufacturer’s warranties or guarantees on the equipment.

The Vendor agrees that the warranty obligations provided by this Agreement shall be reported as an outstanding obligation in the event of bankruptcy, dissolution, or the sale, merger, or cessations of operations of the Vendor.

In the event of a breach of Vendor’s warranty obligations, MaineDOT shall notify Vendor in writing of the breach and grant Vendor 30 days to cure the breach. Should Vendor fail to cure the breach, MaineDOT may pursue whatever remedies may be available.

F. DAMAGES

Time is of the essence in the delivery of the equipment specified herein, and in event of delay(s) in the delivery of the equipment beyond the date set forth in the Agreement, or beyond authorized extensions thereof MaineDOT may impose liquidated damages. Because it is difficult to determine the actual amount of the damage by reason of such delay it is therefore agreed that the Vendor will pay the sum of one hundred dollars (\$100.00) per unit for each calendar day(s) delay in delivery as liquidated damages and not as a penalty.

These damages shall be deducted from any monies due, or which may thereafter become due to the Vendor or may be recovered by through any lawful means.

G. SET-OFF RIGHTS

MaineDOT shall have all of its common law, equitable and statutory rights of set-off.

H. FORCE MAJEURE

Either party may be excused from performance under this Agreement to the extent the failure to perform is caused by acts of God or of the public enemy, fire, floods, epidemics, quarantine, restrictions, strikes, labor disputes, and freight embargos, or other causes beyond the party's reasonable control. In the event of such event of force majeure, the affected party shall provide the other party written notice of the cause of delay within fifteen (15) days from the beginning of any such delay. The time of performance shall be excused to extent of the duration of any such event of force majeure, or such period of time as may be mutually agreed upon by the parties.

I. INDEMNIFICATION

The Vendor shall indemnify and hold harmless MaineDOT and its officers, agents, and employees from and against any and all claims, liabilities, and costs, including reasonable attorney fees, for any or all injuries to persons or property or claims for money damages, including claims for violation of intellectual property rights, arising from the negligent acts or omissions of the Vendor, its employees or agents, officers or Subcontractors in the performance of work under this Agreement; provided, however, the Vendor shall not be liable for claims arising out of the negligent acts or omissions of MaineDOT, or for actions taken in reasonable reliance on written instructions of MaineDOT.

This indemnification provision shall survive any termination or expiration of the Agreement.

J. DEFAULT, TERMINATION

- i. MaineDOT reserves the right to terminate this Agreement or any part hereof, for its sole convenience. Thirty (30) days advance written notice shall be provided in the case of a termination for convenience. In the event of such termination, Vendor shall immediately stop all work hereunder and shall immediately cause any and all of its suppliers and subcontractors to cease work. Vendor shall be paid for all work on a percentage completed basis, as mutually agreed upon by the parties, up to the date of termination under this Paragraph 14.A.

- ii. MaineDOT shall have the right to terminate this Agreement in the event of a material breach or default by Vendor of its obligations hereunder that is not cured within thirty (30) days from the date of receipt by Vendor of written notice of such breach from MaineDOT. If the breach or default, by its nature, cannot be cured within such thirty (30) day period, then Vendor shall have such additional time (not to exceed thirty (30) additional days) as may be necessary to cure the breach or default, provided Vendor has exercised reasonable commercial efforts and taken appropriate action to begin cure of the breach or default within the initial thirty (30) day cure period.
- iii. MaineDOT shall have the right to terminate this Agreement immediately upon written notice to Vendor in the event (i) Vendor, or any director, officer or employee of Vendor assigned to this Project is convicted of a criminal offense directly related to information technology services; or (ii) proceedings in bankruptcy are commenced against Vendor or if a receiver is appointed and such case or proceeding shall continue undismissed, or unstayed and in effect, for a period of one hundred twenty (120) days. Notwithstanding the foregoing, if a conviction of an employee assigned to this Project, officer or director, relates to individual and/or personal actions of such employee, officer or director and not the policy or directive of Vendor and, upon such conviction, Vendor shall terminate or otherwise remove such employee, officer or director and take such other steps to reasonably ensure the propriety of Vendor' delivery of information technology services, then MaineDOT shall not have a right to terminate this Agreement pursuant to the foregoing clause (i) of this Section 14 (C).
- iv. Vendor shall have the right to terminate this Agreement in the event of a material breach or default by MaineDOT of its obligations hereunder that is not cured within thirty (30) days from the date of receipt by MaineDOT of written notice of such breach from Vendor. If the breach or default, by its nature, cannot be cured within such thirty (30) day period, then MaineDOT shall have such additional time (not to exceed thirty (30) additional days) as may be necessary to cure the breach or default, provided MaineDOT has exercised reasonable commercial efforts and taken appropriate actions to begin cure of the breach or default within the initial thirty (30) day cure period.
- v. Vendor shall cause the foregoing provisions to be inserted in any subcontract for any work covered by this Agreement so that such provisions shall be binding upon each subcontractor, provided that the foregoing provisions shall not apply to contracts or subcontracts for standard commercial supplies or raw materials.

K. DELIVERY AND ACCEPTANCE

Time is of the essence in the delivery of the equipment. The Vendor shall execute the work continuously and diligently. Delivery of the units shall occur in accordance with the terms and conditions outlined in the resulting Agreement.

- i. Production of the units shall be conducted as a continuous production with no breaks or inserts of other orders or types of equipment.
- ii. Delivery shall be restricted to Monday through Friday, between the hours of 8 AM and 4 PM.
- iii. The Vendor will contact MaineDOT Fleet Services 24 hrs. prior to delivery with an estimated time of arrival.
- iv. Units furnished under this Agreement shall be delivered in first class condition, complete and ready for operation, and the Vendor shall assume all costs, responsibilities, and risk of loss related to damage that may have occurred in the delivery of the units.
- v. When units are delivered, certificates or releases signed by representatives of MaineDOT Fleet Services are understood to be a simple acknowledgment of receipt of the units only, and will NOT constitute an acceptance of the condition of the units or their conformance with the terms and conditions of the Agreement specifications.
- vi. Upon delivery, MaineDOT may conduct such tests as may be required to determine to its own satisfaction that the units appear to be in conformance with the terms, conditions, and requirements of the Agreement specifications.

Acceptance shall occur following final inspection by authorized employees of MaineDOT Fleet Service, receipt of the titles and all requested documentation. The Vendor will be notified, in writing, of acceptance/non-acceptance within fifteen calendar (15) days of delivery to the location specified in this Agreement.

L. RIGHT TO SUSPEND WORK

MaineDOT has the right to suspend any or all work at any time for any reason as it deems necessary. Consultant may receive payment for the portion of services completed through the date of suspension.

M. COPYRIGHT AND LICENSES - PATENTS AND COPYRIGHTS

Data and publication rights to any documents, produced under the terms of Agreement are the property of MaineDOT. The Vendor shall not copyright the material produced under the terms of the Agreement without written approval of MaineDOT, except to the extent necessary to protect its rights pursuant to the following paragraph.

The Parties to this Agreement mutually agree that, if patentable discoveries, intellectual property and software, or inventions should result from work described therein, all rights accruing from such discoveries or inventions shall be the sole property of MaineDOT.

N. CLAIMS AND DISPUTES

General

To preserve any claim arising out of the Agreement, the Parties shall comply with and exhaust all provisions of this Section. Unless otherwise agreed to in writing, the Vendor shall continue to perform its services during any dispute resolution process. If the Vendor continues to perform, MaineDOT shall continue to make payments in accordance with the Agreement of amounts not in dispute.

Negotiation with MaineDOT's Fleet Representative

The Vendor shall promptly notify MaineDOT's Fleet Representative, or their designee, in writing, of disputes that could significantly affect scope, schedule or compensation. After such notice, the Vendor and MaineDOT's Fleet Representative shall promptly negotiate in good faith to resolve the dispute. MaineDOT's Fleet Representative will promptly issue a decision.

Review by Director

If the Vendor desires a review of MaineDOT's Fleet Representative's decision, then the Vendor shall promptly request in writing that MaineDOT's Director of the applicable Bureau or Office review the Fleet Representative's decision. The Director or its designee(s) shall promptly notify the Vendor in writing of the result of the review.

Dispute Resolution

If the dispute remains unresolved after negotiation and review as set forth above, the Parties may proceed to mediation by selecting a mediator acceptable to both.

If the Parties are unable to resolve the dispute through mediation, either party may seek judicial review through a civil action commenced in the Superior Court of Maine, Kennebec County.

O. CONTROLLING LAWS

The Agreement referred to in these Terms and Conditions is governed by the applicable laws of the Federal Government and the State of Maine.

Laws to Be Observed

The Vendor shall comply with all applicable Federal, State and local laws, rules, regulations, orders, and ordinances affecting the work including, without limitation all environmental, wage, labor, equal opportunity, safety, patent, copyright, or trademark laws. The Vendor shall indemnify MaineDOT and hold MaineDOT harmless against any and all claims or liabilities arising from or based upon the violation or alleged violation of any such Law caused directly or indirectly by or through the Vendor.

P. ENTIRE AGREEMENT/BINDING EFFECT/MODIFICATION/ASSIGNMENT

This Agreement sets forth the entire agreement of the parties with regard to the subject herein. This Agreement may not be modified except by a written amendment executed by both parties.

Neither MaineDOT nor the Vendor may assign, sublet, or transfer any rights under or interest (including, but without limitation, monies that are due or may become due) in the Agreement without the written consent of the other, except to the extent that any assignment, subletting, or transfer is mandated or restricted by law. Unless specifically stated to the contrary in any written Consent To Assignment, no assignment shall release or discharge the assignor from any duty or responsibility under the Agreement.

Q. SEVERABILITY

The invalidity or unenforceability of any particular provision or part thereof of this Agreement shall not affect the remainder of said provision or any other provisions, and this Agreement shall be construed in all respects as if such invalid or unenforceable provision or part thereof had been omitted.

R. NON-WAIVER

If MaineDOT fails or refuses to enforce any provision in the Agreement that shall not constitute a waiver of that provision, nor shall it affect the enforceability of that provision or of the remainder of the Agreement.

Appendix A

**STATE OF MAINE
DEPARTMENT OF ADMINISTRATIVE AND FINANCIAL SERVICES
DIVISION OF PROCUREMENT SERVICES**

BID COVER PAGE and DEBARMENT FORM

Bidder's Organization Name: Hews Company, LLC		
Chief Executive - Name/Title: Robert Hews, President		
Tel: 207-767-2136	Fax: 207-767-5381	E-mail: bhews@hewsc.com
Headquarters Street Address: 190 Rumery Street		
Headquarters City/State/Zip: South Portland, ME 04106		
<i>(provide information requested below if different from above)</i>		
Lead Point of Contact for Bid - Name/Title: SAME		
Tel:	Fax:	E-mail:
Street Address:		
City/State/Zip:		

By signing below Bidder affirms:

- Their bid complies with all requirements of this RFQ;
- This bid and the pricing structure contained herein will remain firm for a period of 180 days from the date and time of the bid opening;
- That no personnel currently employed by the Department or any other State agency participated, either directly or indirectly, in any activities relating to the preparation of the Bidder's proposal;
- That no attempt has been made or will be made by the Bidder to induce any other person or firm to submit or not to submit a proposal; and
- The undersigned is authorized to enter into contractual obligations on behalf of the above-named organization.

Name: Robert E. Hews	Title: President
Authorized Signature: 	Date: September 20, 2018

Debarment, Performance, and Non-Collusion Certification

By signing this document, I certify to the best of my knowledge and belief that the aforementioned organization, its principals, and any subcontractors named in this proposal:

- a. Are not presently debarred, suspended, proposed for debarment, and declared ineligible or voluntarily excluded from bidding or working on contracts issued by any governmental agency.*
- b. Have not within three years of submitting the proposal for this contract been convicted of or had a civil judgment rendered against them for:

 - i. fraud or a criminal offense in connection with obtaining, attempting to obtain, or performing a federal, state or local government transaction or contract.*
 - ii. violating Federal or State antitrust statutes or committing embezzlement, theft, forgery, bribery, falsification or destruction of records, making false statements, or receiving stolen property;*
 - iii. are not presently indicted for or otherwise criminally or civilly charged by a governmental entity (Federal, State or Local) with commission of any of the offenses enumerated in paragraph (b) of this certification; and*
 - iv. have not within a three (3) year period preceding this proposal had one or more federal, state or local government transactions terminated for cause or default.**
- c. Have not entered into a prior understanding, agreement, or connection with any corporation, firm, or person submitting a response for the same materials, supplies, equipment, or services and this proposal is in all respects fair and without collusion or fraud. The above mentioned entities understand and agree that collusive bidding is a violation of state and federal law and can result in fines, prison sentences, and civil damage awards.*

- Failure to provide this certification may result in the disqualification of the Bidder's proposal, at the discretion of the Department.**

To the best of my knowledge all information provided in the enclosed proposal, both programmatic and financial, is complete and accurate at the time of submission.

Name: Robert E. Hews	Title: President
Authorized Signature: 	Date: September 20, 2018

Appendix E

STATE OF MAINE
DEPARTMENT OF ADMINISTRATIVE AND FINANCIAL SERVICES
DIVISION OF PROCUREMENT SERVICES

MUNICIPALITY POLITICAL SUBDIVISION and SCHOOL DISTRICT PARTICIPATION
CERTIFICATION

RFQ # 17D18082300000000000063

14 FOOT PLATFORM BODY

The Division of Procurement Services is committed to providing purchasing opportunities for **municipalities, political subdivisions and school districts** in Maine by allowing them access, through our vendors, to our contract pricing. A bidder's willingness to extend contract pricing to these entities will be taken into consideration in making awards.

Will you accept orders from political subdivisions and school districts in Maine at the prices quoted?

Yes

Yes, with conditions as follows:

No

Name of Company: Hews Company, LLC

Address: 190 Rumery Street, South Portland, ME 04106

Signature: _____

Date: September 20, 2018

Appendix F

RFQ # 17D18082300000000000063

14 FOOT PLATFORM BODY

CERTIFICATIONS

1.0 NONCOLLUSION BIDDING CERTIFICATION

By submission of this Bid, each Bidder and each person signing on behalf of any Bidder certifies, and in the case of a joint bid, each party certifies as to its own organization, under penalty of perjury, that to the best of its knowledge and belief:

1. The prices in this Bid have been arrived at independently without collusion, consultation, communication or agreement, for the purpose of restricting competition as to any other matter relating to such prices with any other Bidder or with any other competitor;
2. Unless otherwise required by law, the prices which have been quoted in this Bid have not been knowingly disclosed by the Bidder and will not knowingly be disclosed by the Bidder prior to opening, directly or indirectly, to any other Bidder or to any competitor; and,
3. No attempt has been made or will be made by the Bidder to induce any other person, partnership or corporation to submit or not to submit a Bid for the purpose of restricting competition.

Dated: September 19, 2018

Printed name of Person Bidding

Robert E. Hews



Authorized Signature

Title: President

2.0 EQUIPMENT PERFORMANCE AND WARRANTY DATA

The information provided on this form will be used in determining operating costs of the equipment. Bidder must complete this form and submitted with bid. Bids received without this information will be considered non-responsive to the bid.

1. **EQUIPMENT:**

2. **DESCRIBE THE PROCESS FOR THE SUBMISSION OF WARRANTY CLAIMS FOR REIMBURSEMENT OUTLINED AND SUBMITTED WITH THE BID. (written process to follow for reimbursement of warranty claims)**

3. **EQUIPMENT INFORMATION:**

YEAR: 2018 EQUIPMENT MAKE: READING

EQUIPMENT MODEL: H14W

4. **MANUFACTURER'S RECOMMENDED PREVENTATIVE MAINTENANCE SCHEDULE MUST BE PROVIDED**

See Attached Preventative Maintenance Schedule

5. **BASIC EQUIPMENT WARRANTY DESCRIPTION**

See Attached Equipment Warranty Description

6. **NAME/LOCATION OF REPAIR FACILITY(S)** (BOTH AUTHORIZED WARRANTY, PARTS & SERVICE PER REQUESTED LOCATION). It is desired that at least one facility is located within 75-mile radius each region headquarters: Scarborough, Augusta, Dixfield, Bangor and Presque Isle.

WARRANTY AND SERVICE FACILITIES: Hews Company, LLC

ADDRESS 1: 190 Rumery Street, South Portland, ME 04106

ADDRESS 2: 4 Ryan Road, Bow, NH 03304

ADDRESS 3:

ADDRESS 4:

ADDRESS 5:

CONTACT NAME: Dennis Harmon

TELEPHONE: 207-767-2136

EQUIPMENT PARTS PROVIDER: Hews Company, LLC

ADDRESS: 190 Rumery Street, South Portland, ME 04106

CONTACT NAME: Dave Gain

TELEPHONE: 207-767-2136

Attach written explanation describing the locations of the facilities, the contact name and number at each

facility, the times the facilities will be available for use, the qualifications of the staff at the facilities and how the vendor will provide warranty and service at these service facilities.

Bidder certifies that they have service facilities in Maine, staffed with trained service technicians and stocked with repair parts for the equipment which is bid.

This form must be reproduced and completed for any additional equipment warranty/facility information.

Dated: September 20, 2018

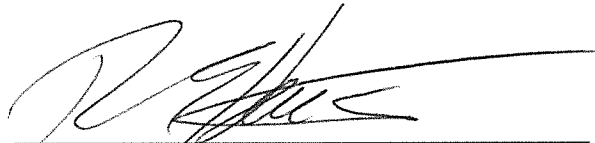

Signature

Print Name
Robert E. Hews, President

Company Name: Hews Company, LLC

3.0 SPECIFICATION COMPLIANCE

The bidder hereby certifies that the equipment(s) being bid in response to this invitation meet or exceed these specifications and that where a deviation from the specifications exists, the bidder has obtained written approval of those exceptions prior to submitting this bid.

If a conflict exists between these specifications and Federal and/or State laws, the Federal and/or State laws shall prevail and the bidder must alert the purchaser to any such conflicts.

Dated: September 20, 2018

Printed name of Person Bidding
Robert E. Hews



Authorized Signature

Title: President

Appendix B

**STATE OF MAINE
DEPARTMENT OF ADMINISTRATIVE AND FINANCIAL SERVICES
DIVISION OF PROCUREMENT SERVICES**

DETAILED SPECIFICATIONS

RFQ # 17D18082300000000000063

14 FOOT PLATFORM BODY

INTENT

The purpose and intent of this specification is to describe an approximately 14' Platform Body with fixed bulkhead and removable stake sides. Specifications include four options to be priced separately.

- Option 1 - lift gate with a minimum of 1,600 lbs. capacity
- Option 2 - pull-down step that can be stored in place when not in use
- Option 3 - hinged Swing Gate Kit
- Option 4 - hydraulic body hoist with a minimum 6-ton capacity
- Installation cost

Bodies will be mounted on a latest model year Ford F-550 with 108" CA dimension, 19,500 lb. GVW rating, dual rear wheels, gas or diesel engine and automatic transmission. MaineDOT estimates three (3) units, however, the state reserves the right to order more or less as needed (depending on funding) for two (2) calendar years. Individual stake bodies may be purchased separately or with any combination of listed options. Individual options may be ordered to be installed on platform bodies already in MaineDOT service.

COMPLETENESS

The price quoted in any proposal submitted shall include all items of labor, materials, and other costs necessary to fully complete the manufacture and delivery of the platform/rack body pursuant to these specifications.

Any part or detail which makes the platform/rack body complete and ready for service shall not be omitted, even though such part is not mentioned in these specifications.

CONFORMITY

All parts not specified shall be manufacturer's best quality and shall conform in materials, design, or workmanship to the best practice known in the platform/rack body industry. All parts shall be new and in no case will used, reconditioned or obsolete parts be accepted. The parts on all platform/rack bodies provided by the manufacturer should be interchangeable.

INSTRUCTIONS FOR COMPLETING TECHNICAL SPECIFICATION SHEET

Please complete the checklist for technical specifications set forth below.

Electronically enter responses directly into the text-enabled fields next to each specification, including actual dimensions when applicable. Each Bidder must indicate whether it can meet the technical specifications by inserting an “X” next to each specification. The “X” will demonstrate that the Bidder’s offering meets the technical specification. If a Bidder cannot meet a technical specification, then the Bidder must give an explanation for each exception and for equipment that is not available or that will be dealer installed. All explanations must be provided in detail on separate pages along with the justification as to why the alternative equipment or deliverables will be as good as the equipment or deliverables described in the detailed specifications for desired items. A copy of the vendor specification proposal must be provided. Following these instructions is essential for proper bid evaluation.

If a Bidder fails to provide requested information or if information on a quote is found to be false or misleading, the quote will be rejected as unresponsive. The award will be made on a best value basis to the vendor that either meets or most closely meets the specifications, while taking price and delivery into consideration.

The following abbreviations must be used:		X	Standard or as specified	
		N/A	Not Available	
		DI	Dealer Installed	
		AE	Approved Equal	
	2.0 CONSTRUCTION	Abbreviation	Actual Dimension	Notes
2.1	End rails and side rails shall be a minimum 5 5/8" 12 11 ga. Roll formed high-strength steel.	A/E		11 ga. Roll Formed
2.2	Crossmembers shall be a minimum of 4-inch 11 ga. Roll formed high-strength "C-G" channel.	A/E		Formed "G" Channel
2.3	Crossmember spacing shall be a minimum of every twenty-four (24) inches.	X		Exceeds: 13' Average Centers
2.4	Gussets shall be front and rear rails along with every other crossmember.	X		

2.5	Long sills shall be a minimum of 4-inch 10ga. formed channel, and install with a minimum of 34-inch spacing, minimum length shall be 116".	X	173 ¼"	Exceeds: 7" 9.8# Structural Steel.
2.6	Flooring shall be 2-inch x 6-inch tongue and groove-Shiplap, Yellow Southern-treated dense pine.	A/E	2" Nominal X 6.5"	Shiplap
2.7	Lights shall be LED and recessed mounted in shock resistant rubber grommets and loom protected wires.	X		
2.8	Stake pockets shall be 1.7-inch x 3.75 inch reinforced on 24-inch centers.	X		
2.9	Stake racks shall be a minimum of 40 inches high.	X	42"	Exceeds
2.10	Stakes shall be made from a minimum of 14ga. galvanized steel.	X		
2.11	Slats shall be made from a minimum of 16ga. steel and roll formed.	X		
2.12	Attaching hardware shall be spring loaded, anti-rattle, heavy-duty hardware.	N/A		Each rack equipped with locking device to prevent accidental removal.
2.13	Bulkhead shall be rectangular drop in 40 inches high and 96 inches wide with Hole Punched or Mesh center window.	X	42" x 90 ¼"	Punched metal window.
2.14	Bulkhead shall have minimum 12" reinforced Cab Plate to support accessories such as ladders and Emergency Lights – 12" footprint, flat on top.	X		
2.15	Bulkhead shall be welded in place to the front rub rail.	X		
2.16	Hitch shall use a 2½" square receiving opening.	X		

2.17	Hitch shall attach to the vehicle frame only.	X		
2.18	Hitch shall be a class V, rated up to 16,000 lbs. gross trailer weight, with 7-prong Round pin trailer plug-in (See wire diagram). RV plugs will not be accepted.	A/E		2" Receiver hitch rated 17,000 lbs, Model 1809055 (Current MDOT spec on platform bodies) with 7" prong round.

Circuits	Code #	Marking	Color Code
Ground	1	W	White
Clearance, Side Marker & Identification Lamps	2	BK	Black
Left Turn & Hazard Signal	3	Y	Yellow
Top Lamps & Anti-Lock Devices	4	R	Red
Right Turn Signal & Hazard Signal	5	G	Green
Tail, Rear Clearance Marker, & Plate Lamps	6	BR	Brown
Auxiliary Circuit	7	BL	Blue

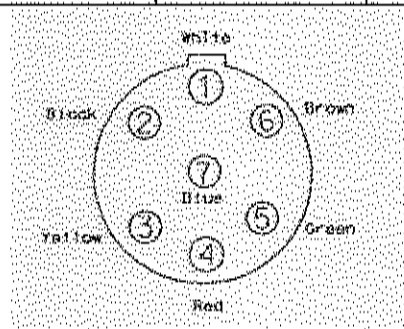

2.19	All components shall be E-Coat priming and corrosion protection.	X		
2.20	No wiring shall run through the stake pockets or an area where it can be pinched.	X		

2.21	All exterior trailer wiring shall be professionally installed and run in suitable weather resistant loom or conduit (professionally secured).	X		
2.22	All wire splicers/connectors (if applicable) shall be shrink tube barrel type or soldered and shall be sealed with weather-proof automotive type shrink tubing, Scotch lock type (wire piercing) connectors are not acceptable in any application.	X		
3.0 WARRANTY		Abbreviation	Actual Dimension	Notes
3.1	Manufacturer's standard warranty will apply.	X		
3.2	Terms and conditions of warranty must be provided with bid proposal.	X		
3.3	Manufacturer's warranty will start with the in-service date	X		
4.0 GENERAL		Abbreviation	Actual Dimension	Notes
4.1	Bid price of body shall include mounting and all hardware to install on latest model Ford F550 with a 108-inch CA with dual wheels and delivery to MaineDOT Fleet Services in 66 Industrial Drive Augusta, ME 04330.	X		
4.2	Body and all components shall be black in color.	X		
4.3	Be it known that these specifications are a minimum and that bids will be evaluated based on price, warranty, manufacturer's performance data, delivery schedule, parts availability and other items deemed appropriate.	X		
4.4	Bidders are required to provide sufficient information with their bid such as manufacturer's brochures, specification	X		

	sheet, etc. and to certify that they have service facilities in Maine, staffed with trained service technicians and stocked with repair parts for the equipment which is bid. Failure to provide this information may cause the bid to be rejected. Maine DOT reserves the right to reject any and all bids.			
4.5	Body must comply with the Department of Transportation Federal Motor Vehicle Safety Standards and Department of Labor Occupational Safety and Health Standards. Lighting equipment shall meet FMVSS # 108.	X		
4.6	Exceptions to specifications shall be listed on a separate paper and noted as exceptions and submitted with bid proposal. If exceptions are not listed as such it shall be considered that the vendor will comply with all specifications as listed.	X		
4.7	Backup alarm conforming to SAEJ 994 and OSHA requirements.	X		
	5.0 OPTION 1 - LIFT GATE	Abbreviation	Actual Dimension	Notes
5.1	Lift gate shall have a minimum capacity of 1,600 lbs.	X		
5.2	Lift gate shall be a minimum of 82 inches wide and 36 inches in height.	X	90"W x 32" + 8" ramp.	Option A: Option B:
5.3	Lift gate shall have cam activated power close.	X		
5.4	Lift gate shall include latch chains for transit.	X		
5.5	Lift gate shall have adjustable cylinder rod and clevis.	X		
5.6	Lift gate shall meet TMC electrical requirements.	X		

5.7	Power source for controlling the movement of the lift gate shall be a 12-volt self-contained hydraulic pump.	X		
5.8	Lift gate shall conform to fit rack body specifications above (non-dumping).	X		
5.9	Lift gate and components shall be black in color.	X		
6.0 OPTION 2 - STEP		Abbreviation	Actual Dimension	Notes
6.1	Step shall be a pull out and flip down type with a minimum weight capacity of 350 lbs.	X		
6.2	Step shall have a minimum of two (2) rungs spaced no more than 12 inches apart.	X		
6.3	Step shall be a minimum of 11 inches in width.	X		
6.4	Step shall be stored within or under the body frame and have a mechanism to prevent losses of step while the vehicle is in motion.	X		
6.5	Step shall have a grip surface to provide for maximum traction.	X		
6.6	Ladder will be located at the right rear corner of the body facing the rear.	X		
7.0 OPTION 3 - SWING GATE		Abbreviation	Actual Dimension	Notes
7.1	Swing Gate shall be galvanized galvanized steel posts and slats; rear swing gates with a heavy-duty bolt-on hinge assemblies.	X		Exceeds: Galvanized steel.
8.0 OPTION 4 - BODY HYDRAULIC HOIST		Abbreviation	Actual Dimension	Notes
8.1	Hydraulic hoist shall have a minimum 6-ton capacity with integral safety prop.	X		

8.2	Power source for controlling the movement of the hydraulic hoist dump shall be a 12-volt self-contained hydraulic pump.	X		
8.3	Dump/Hoist assembly shall be of lowest type mounting available but should not preclude a sub frame if necessary.	X		
8.4	Body support, permanently attached, capable of being locked in place.	X		
8.5	Power up and down.	X		
8.6	Body longitudinal must not be cut to accommodate the hoist assembly.	X		
BODY PRICE (information required)				
Body Make & Model Number: Reading Heavy Duty Platform / Model H14W				
\$ 4,945.00 each				
9.0 INSTALLED OPTIONS (additional costs)				
	Installed Option	Model	Price	Notes
9.1	Lift Gate System – OPTION A: Thieman	TWL 16ET	\$3,955.00 each	
9.1	Lift Gate System – OPTION B: Palfinger	E50-91	\$3,555.00 each	Compatible with Hoist application (Dump Over)
9.2	Step System	EZ Step 3-Rung	\$ 400.00 each	
9.3	Swing Gate	Reading	\$ 655.00 each	Bolt-on Corner Posts
9.4	Hydraulic Hoist – Omaha Conversion	519DAE	\$ 3,465.00 each	Compatible with E50-91 Liftgate only
9.5	Labor to install complete body, bumper, hitch and delivered		\$ 2,240.00 each	

Please Include F.O.B. Destination shipping in your bid pricing!

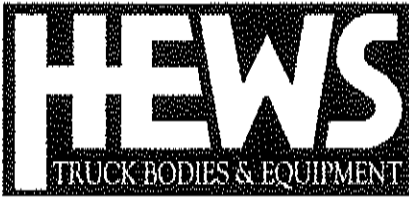

HEWS COMPANY, LLC
 190 RUMERY STREET
 SOUTH PORTLAND ME 04106
 PHONE: (207) 767-2136
 FAX: (207) 767-5381

Page: 1

ATTN:
 STATE OF MAINE/PURCHASES DIV.
 BURTON CROSS BLDING, 4TH FLOOR
 STATE HOUSE STATION #9
 AUGUSTA ME 04333

Quote Date: 09/07/18
 Order #: U73310
 Sales Rep: MATT HILSE
 Customer #: 6317
 Telephone #: 207-624-7876
 Fax #: 207-287-6578

=====

STATE OF MAINE RFQ 17D18082300000000000063 DUE 9/20/2018 4:00 PM

- 1- READING PLATFORM STAKE BODY H14W - 13560004
- 173.25" x 96" platform
- 4" 11 GA. formed G-Channel high strength crossmembers-13" average centers.
- 7" 9.8# structural steel longitudinal sills.
- 11 GA roll formed high strength galvanized steel side and end rails.
- Reinforced 1.7" x 3.75" stake pockets at 24" centers.
- 2" Nominal x 6.5" Pressure treated dense southern yellow pine floor (SHIPLAP).
- 42" Galvanized steel headboard with punched metal window (WELD-IN)
- 12" wide x 90.25" long reinforced steel plate on top of headboard.
- 42" 16 GA. roll formed Galvanized steel rack sides and rear. (REMOVABLE)
- Each rack equipped with locking device to prevent accidental removal.
- LED Marker & Clearance lights in "shock resistant" rubber grommets.
- 12-Stage full immersion acrylic priming process.
- Electro-static Black Powder Coat Finish (No VOCs).

NOT INSTALLED, FOB, SOUTH PORTLAND, ME

\$4,945.00 EA

INSTALLATION:

Body, Headboard, back-up alarm, ICC, Flaps ADD: \$1,540.00
 Use chassis S/T/T & backup lights.

Bolt-on 2" Receiver hitch with "D" Rings, ADD: \$ 700.00
 Rated for 17,000 lbs (Used on Maine DOT platform bodies)
 and Part #593083, 7-pin round plug

*** CONTINUED NEXT PAGE ***



HEWS COMPANY, LLC
 190 RUMERY STREET
 SOUTH PORTLAND ME 04106
 PHONE: (207) 767-2136
 FAX: (207) 767-5381

ATTN:
 STATE OF MAINE/PURCHASES DIV.
 BURTON CROSS BLDING, 4TH FLOOR
 STATE HOUSE STATION #9
 AUGUSTA ME 04333

Quote Date: 09/07/18
 Order #: U73310
 Sales Rep: MATT HILSE
 Customer #: 6317
 Telephone #: 207-624-7876
 Fax #: 207-287-6578

=====

OPTIONS: (INCLUDES INSTALLATION)

- 1(A). THIEMAN TWL 16ET CONVENTIONAL LIFTGATE ADD: \$3,955.00
- 1,600 lb. capacity.
 - Single raise cylinder.
 - Cam activated power close.
 - Adjustable cylinder rod and clevis.
 - Steel Platform: 90" X 32"+ 8" Taper.
 - 150 AMP circuit breaker.
 - Plastic power unit enclosure.
 - Toggle switch control. (CURB SIDE)
 - Bed height range: 37" - 52"
 - Reflective tape.

***NOTES: ELIMINATES REAR 42" RACK SECTIONS FROM BODY
 NOT COMPATIBLE WITH HOIST APPLICATION

- 1(B) PALFINGER E50-91 LIFTGATE ADD: \$3,555.00
- Capacity: 1600 LBS
 - Platform: 86" x 34" + 4" Taper. Tread Plate Steel.
 - Quick release sure-hold safety locks.
 - Drop away platform for Dock Loading.
 - Electric hydraulic pump, built in relief valves.
 - Oil impregnated bronze bushings at all pivot points.
 - 150 amp circuit breaker.
 - Power cut off integrated with vehicle switch.
 - Toggle switch control.
 - Automotive Grade E Coat Black Topcoat paint.
 - Use existing chassis S/T/T & back-up lights.
 - Reflective Tape.

***NOTES: ELIMINATES REAR 42" RACK SECTIONS
 COMPATIBLE WITH HOIST APPLICATION (DUMP OVER)

*** CONTINUED NEXT PAGE ***



HEWS COMPANY, LLC
 190 RUMERY STREET
 SOUTH PORTLAND ME 04106
 PHONE: (207) 767-2136
 FAX: (207) 767-5381

ATTN:
 STATE OF MAINE/PURCHASES DIV.
 BURTON CROSS BLDING, 4TH FLOOR
 STATE HOUSE STATION #9
 AUGUSTA ME 04333

Quote Date: 09/07/18
 Order #: U73310
 Sales Rep: MATT HILSE
 Customer #: 6317
 Telephone #: 207-624-7876
 Fax #: 207-287-6578

- =====
 2. EZ STEP 3-RUNG PULL OUT STEPS ADD: \$ 400.00
 - MOUNT LOCATION: CURB SIDE REAR OF BODY
 NOTE: NOT USABLE IN THIS LOCATION WITH LIFTGATE
3. SWING REAR RACKS WITH BOLT-ON CORNER POSTS ADD: \$ 655.00
4. OMAHA CONVERSION MODEL 519DAE HOIST ADD: \$3,465.00
 - CLASS "40" - 5.8 TO 14.4 TON CAPACITY
 - Double acting electric hydraulic powered hoist.
 - Frame mounted, no subframe.
 - In-cab controls.
 - Body prop & 150 amp circuit breaker
 ***NOTE: COMPATIBLE WITH E50-91 LIFTGATE ONLY

SALESPERSON: MATT HILSE / BOB HEWS

=====
 VIN: FLEET ID: CAB/CHASS
 MAKE/MODEL: FORD F-550 DRW YEAR: 2018/19
 TRANS: AUTO ENGINE: GAS/DSL
 GVW: 19500 CA: 108"

Please sign order
 and return 1 copy

TERMS:
 N30

Sub-Total 4,945.00
 F.E.T. 0.00
 Sales Tax 0.00

 Signature Date

Total 4,945.00

QUOTE VALID FOR 30 DAYS



TRANSPORTATION EQUIPMENT SPECIALISTS

190 RUMERY STREET
SOUTH PORTLAND, ME 04106
TEL (207) 767-2136
FAX (207)767-5381

4 RYAN ROAD
BOW, NH 03304
TEL (603) 226-3252
FAX (603) 224-6279

Made to Order. Made to Last.

1-800-234-4397
Email: info@hewscos.com

RFP # 17D18082300000000000063
BID SPECIFICATIONS – EXCEED OR EQUAL TO

THE HEWS COMPANY, LLC'S BODY SPECIFICATIONS ARE EQUAL TO OR EXCEED THE 14' PLATFORM BODY REQUIREMENTS, AS SUMMARIZED BELOW:

PLATFORM BODY:

- 2.1 Exceed – 11 Gauge Roll Formed
- 2.2 Exceed – 11 Gauge Roll Formed "G" Channel
- 2.3 Meets – 13" Average Centers
- 2.4 Meets
- 2.5 Meets – 7" 9.8# Structural Steel, 173 ¼" Long
- 2.6 Approved Equal – 2" Nominal ½" Shiplap, Yellow Southern Treated Dense Pine
- 2.7 Meets
- 2.8 Meets
- 2.9 Meets – 42"
- 2.10 Meets – 14ga Galvannealed steel
- 2.11 Meets
- 2.12 Not Available – Each Rack equipped with locking device to prevent accidental removal
- 2.13 Not Available – 42" x 90 ¼" Punched Metal Window
- 2.14 Meets
- 2.15 Meets
- 2.16 Meets
- 2.17 Meets
- 2.18 Not Available – 2" Receiver hitch rated 17,000 lbs (Current MaineDOT Spec on Platform bodies), model 1809055, with 7-prong round plug
- 2.19 Meets

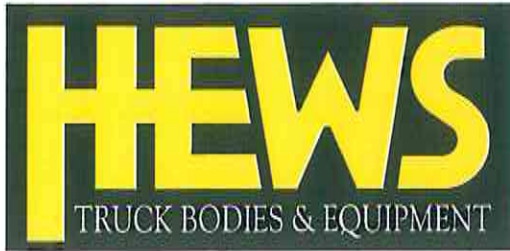

TRANSPORTATION EQUIPMENT SPECIALISTS

190 RUMERY STREET
SOUTH PORTLAND, ME 04106
TEL (207) 767-2136
FAX (207)767-5381

4 RYAN ROAD
BOW, NH 03304
TEL (603) 226-3252
FAX (603) 224-6279

1-800-234-4397

Email: info@hewscsco.com

Made to Order. Made to Last.

- 2.20 Meets
- 2.21 Meets
- 2.22 Meets

WARRANTY:

- 3.1 Manufacturers Warranty: Reading's Standard Limited Warranty is 3-Years.
- 3.2 Reading Warranty card is attached.
- 3.3 Reading warranty, as specified, will start with the in-service date.

GENERAL

- 4.1 Bid price includes mounting and installation on Ford F550 DRW with 108" CA, with delivery to MaineDOT Fleet Services in Augusta.
- 4.2 Meets
- 4.3 Meets
- 4.4 Manufacturers brochures and spec sheet are attached to the bid. The Hews Company maintains a 28,000 square foot facility with 14 technicians, five of whom are ASE Certified. Please see attached NTEA Member Verification Program (MVP) Certification that describes the Hews Company's recognition in the work truck industry for outstanding business practices and successful implementation of quality standards.
- 4.5 Meets
- 4.6 Meets
- 4.7 Meets

OPTION 1 - LIFTGATE:

- 5.1 Exceeds – Hews has provided two options for liftgates. Option A is a Thieman TWL 16ET with 1,600 lb capacity. Option B is a Plafinger E50-91 Liftgate that has a capacity of 1,600 lbs, and is compatible with the Dump Over Hoist Application. The E50-91 is the liftgate currently used on the MaineDOT 9.3' Platforms.
- 5.2 Meets
- 5.3 Meets



TRANSPORTATION EQUIPMENT SPECIALISTS

190 RUMERY STREET
SOUTH PORTLAND, ME 04106
TEL (207) 767-2136
FAX (207)767-5381

4 RYAN ROAD
BOW, NH 03304
TEL (603) 226-3252
FAX (603) 224-6279

Made to Order. Made to Last.

1-800-234-4397
Email: info@hewscsco.com

- 5.4 Meets
- 5.5 Meets
- 5.6 Meets
- 5.7 Meets
- 5.8 Meets
- 5.9 Meets

OPTION 2 - STEP

- 6.1 Meets
- 6.2 Meets
- 6.3 Meets
- 6.4 Meets
- 6.5 Meets
- 6.6 Meets

OPTION 3 – SWING GATE

- 7.1 Meets

OPTION 4 – BODY HYDRAULIC HOIST

- 8.1 Meets
- 8.2 Meets
- 8.3 Meets
- 8.4 Meets

PLATFORM BODIES



— NO BODY BETTER —



Made in
the USA



Platform Bodies
VERSATILE | DURABLE | RUGGED

Platform Bodies

Premium materials, superb craftsmanship, and advanced production techniques make Reading Platform Bodies the preferred choice for every hauling job. The versatile Reading Platform Body is built tough to handle whatever your job requires. From the A60 coating weight galvanealed coated steel construction and reinforced steel understructure to the multiple floor and side options, every inch of a Reading Platform Body means business.

STANDARD FEATURES

- 1 Acrylic E-Coat Priming** – A 12-step electrified immersion process that fuses the primer to every surface, even hidden recessed areas. Provides the best possible protection against rust and corrosion.
- 2 Black Powder Coat Finish*** – Smooth and highly durable polyester powder topcoat is baked on to provide outstanding protection against rust, corrosion, and the rigors of daily use.
- 3 Standard Lighting** – Recessed lights have impact resistant, reflective lenses and rubber grommets. They include wiring harnesses for clearance, marker and identification lights.
- 4 Rugged Steel Girder Understructure** – Two full-length structural steel longitudinal sills reinforced front to rear on both sides by multiple steel gussets. Longitudinal sills and full-width heavy gauge crossmembers are interlocked and welded to the one-piece steel side and end rails.**
- 5 Steel Platform** – Smooth surface is protected with our primer and powder coat finish and allows for easy loading/unloading.
- 6 Platform Rails** – A60 coating weight galvanealed construction with roll-formed rails on sides and rear featuring precision pre-punched pocket holes. The platform edges meet at 90° corners.
- 7 Deep Reinforced Stake Pockets** – Extend from the top to the bottom of the platform rail and are designed to hold optional stakes or body sides firmly in place. They are reinforced with a heavy-gauge steel box welded into the side rail.

* Also available in prime paint only.

**All factory installed longitudinal sills are located for 34" wide frames.

If a different sill location is required, complete chassis information and desired dimensions must be supplied when placing order.

FLOOR OPTIONS



Pressure Treated & Stained Yellow Pine

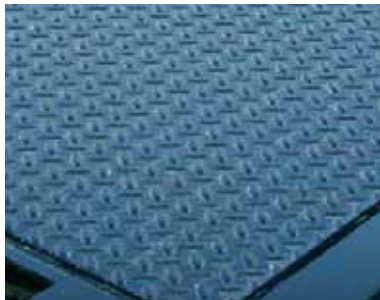

Deck Plate Steel



Apitong Hardwood



BULKHEAD OPTIONS

All available in 42" and 52" heights

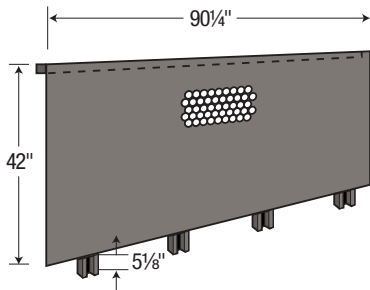

Solid with window – 12-gauge bulkhead with 14-gauge posts.

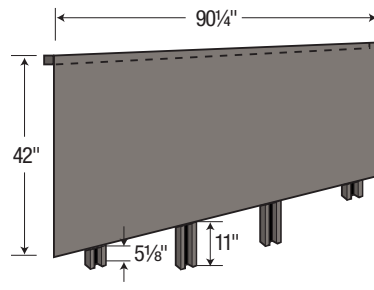

Solid Long Sill Reinforced – 12-gauge bulkhead with 14-gauge posts, with two center posts extending down platform long sills.

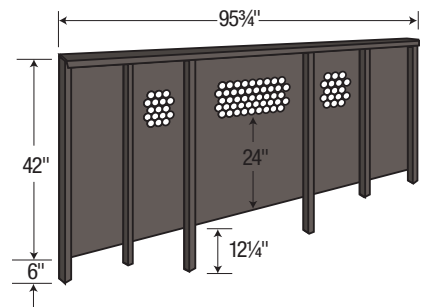

Extra Heavy-Duty – 10-gauge bulkhead with six 3" posts of 4.1 structural steel channel. Optional 11" x 27" window available at additional cost. Only available for extra-heavy-duty stake bodies.

SIDE OPTIONS

Steel Stake Racks

Reading racks provide safe, secure support for your load. Built without compromise, they feature the best protection available against rust, corrosion, and the rigors of daily use.

- Posts are die formed, and steel slats are roll formed and die crimped
- Posts are arc welded to slats to form steel stake racks
- Extra heavy-duty stake pocket platforms have racks made with 12-gauge A60 coating weight galvanized steel posts and 16-gauge A60 coating weight galvanized steel slats
- The base of each stake rack is reinforced at and above the floor line
- 42"-high racks have four horizontal slats. All racks are spaced on 24" centers
- Acrylic E-Coat immersion primed and furnished with a durable baked-on powder coat top coat for the ultimate protection against rust and corrosion



Shown with optional equipment

Quick Release Latches

- A spring-loaded latch on one post of each rack holds it firmly in the stake pocket. To remove rack, simply trip the latch and lift the rack.
- All racks lift out individually for easier loading and unloading. Each rack section is secured to the adjoining section by a sturdy quick-release gate latch.



Cutaway showing quick-release spring latch

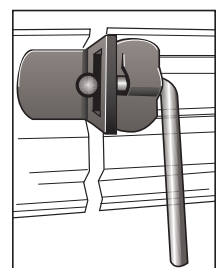

Quick-release gate latch

Redi-Racks

Redi-Racks provide an effective, economical and versatile solution for hauling loose bulk loads. Forward side racks can be removed individually for easy loading of pallet materials.

- 14-gauge A60 galvanized steel posts with 16-gauge perforated sides
- Grab handle bar on outside of Redi-Rack aids in lifting rack and can be used as a tarp tie-down
- Swing-out gates at rear
- Gates feature an upper rack connector, a spring-loaded rack lock, and hold backs for keeping the racks in a fully open position



Contractor Sides

- 12-gauge A60 galvanized steel construction
- Sides are 14" high and removable
- A solid bulkhead is standard with contractor sides, window optional
- 4-way double hinged tailgate that is fully welded and reinforced
- Fold-down contractor sides also available

Shown with optional equipment

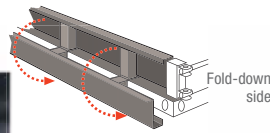

Contractor Sides

Model	Approx. Wt.
CS9	430lbs.
CS10	450lbs.
CS12	470lbs.
CS14	500lbs.
CS16	530lbs.
CS18	600lbs.
CS20	670lbs.

Includes 14" sides, 14" 4-way tailgate and 42" solid bulkhead.

Fold-Down Contractor Sides

Model	Approx. Wt.
FDCS9	470lbs.
FDCS10	490lbs.
FDCS12	518lbs.
FDCS14	556lbs.
FDCS16	594lbs.
FDCS18	672lbs.
FDCS20	750lbs.

Includes 14" fold-down sides, 14" 4-way tailgate and 42" solid bulkhead.

4-way double-hinged tailgate

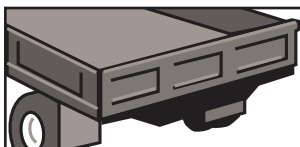

Close it for hauling

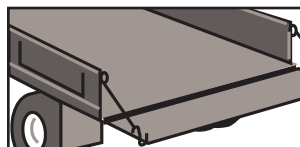

Open level to extend platform

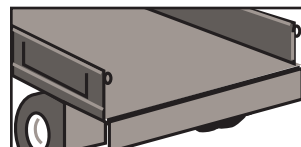

Lower 180° for unloading

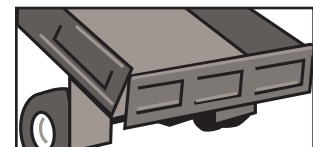

Open from bottom for dumping

OPTIONAL EQUIPMENT

Rear Swing-out Racks

Permits rear racks to open freely without lifting them out of the stake pockets.



Subframe Hoist

- Double-acting (power-up/power-down) 12-volt electric hydraulic power unit for ease of operation
- Hydraulic pump, plumbing and wiring included with complete hoist package
- Large diameter cylinder for increased hydraulic pressure and maximum lifting capacity
- Concentrated seal and cylinder packing for leak-free operation
- Low mount subframe easily attaches to chassis truck frame
- Black powder coat finish

Available on Special Order:

- Extra crossmembers (12" centers)

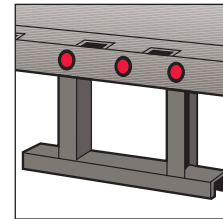

ICC bumper

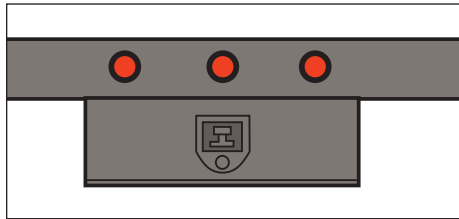

"Possum Belly" Compartment

Storage tunnel under platform and between long sills with hinged access door

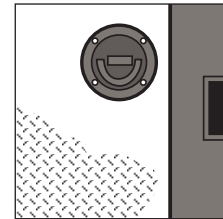

Heavy-duty recessed tie-down rings

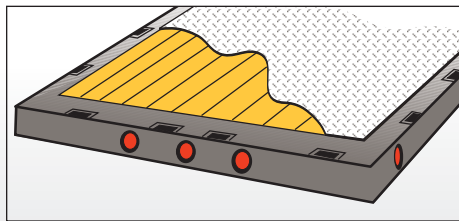

Deck Overlay

3/16" deck plate steel over wooden floor

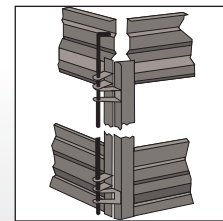

Lift up swing-out hinges



PROVIDES PEACE OF MIND DOWN THE ROAD



DIMENSIONAL DATA

96" Width Heavy-Duty Platforms					
Size	Model	Cab-to-Axle	Floor Type	Platform Weight	Rack Weight
9'	H9P	60"	3/16" Smooth Steel	1,075lbs.	375lbs.
	H9D		3/16" Deck Plate	1,155lbs.	
	H9W		2" (nominal) Wood	830lbs.	
10'	H10P	60-72"	3/16" Smooth Steel	1,160lbs.	410lbs.
	H10D		3/16" Deck Plate	1,235lbs.	
	H10W		2" (nominal) Wood	885lbs.	
12'	H12P	84"	3/16" Smooth Steel	1,395lbs.	490lbs.
	H12D		3/16" Deck Plate	1,490lbs.	
	H12W		2" (nominal) Wood	1,065lbs.	
14'	H14P	102-108"	3/16" Smooth Steel	1,620lbs.	545lbs.
	H14D		3/16" Deck Plate	1,735lbs.	
	H14W		2" (nominal) Wood	1,225lbs.	
16'	H16P	114-126"	3/16" Smooth Steel	1,850lbs.	580lbs.
	H16D		3/16" Deck Plate	1,990lbs.	
	H16W		2" (nominal) Wood	1,455lbs.	
18'	H18P	120-132"	3/16" Smooth Steel	2,040lbs.	640lbs.
	H18D		3/16" Deck Plate	2,200lbs.	
	H18W		2" (nominal) Wood	1,530lbs.	
20'	H20P	137-149"	3/16" Smooth Steel	2,235lbs.	695lbs.
	H20D		3/16" Deck Plate	2,410lbs.	
	H20W		2" (nominal) Wood	1,665lbs.	
22'	H22P	146-158"	3/16" Smooth Steel	2,640lbs.	760lbs.
	H22D		3/16" Deck Plate	2,655lbs.	
	H22W		2" (nominal) Wood	1,835lbs.	
24'	H24P	165-192"	3/16" Smooth Steel	2,690lbs.	820lbs.
	H24D		3/16" Deck Plate	2,900lbs.	
	H24W		2" (nominal) Wood	2,005lbs.	

Heavy-Duty Platform Construction

Longitudinal sills of structural steel channel ranging from 6" 8.2 lbs. to 8" 11.5 lbs. Crossmembers are of 11-gauge roll formed "G" channel on 15" centers (average). 5-3/4" High rails are roll formed of 11-gauge A60 two-sided coated steel. Each stake pocket is reinforced with a 12-gauge steel box welded into the rails.

Extra Heavy-Duty Platforms (96" width for all platforms)					
Size	Model	Cab-to-Axle	Floor Type	Platform Weight	Rack Weight
12'	EH12P	84"	3/16" Smooth Steel	1,915lbs.	350lbs.
	EH12D		3/16" Deck Plate	2,010lbs.	
	EH12W		2" (nominal) Wood	1,585lbs.	
14'	EH12P	102-108"	3/16" Smooth Steel	2,205lbs.	390lbs.
	EH12D		3/16" Deck Plate	2,340lbs.	
	EH12W		2" (nominal) Wood	1,830lbs.	
16'	EH16P	114-126"	3/16" Smooth Steel	2,530lbs.	430lbs.
	EH16D		3/16" Deck Plate	2,670lbs.	
	EH16W		2" (nominal) Wood	2,065lbs.	
18'	EH18P	120-132"	3/16" Smooth Steel	2,790lbs.	480lbs.
	EH18D		3/16" Deck Plate	2,950lbs.	
	EH18W		2" (nominal) Wood	2,280lbs.	
20'	EH20P	137-149"	3/16" Smooth Steel	3,055lbs.	520lbs.
	EH20D		3/16" Deck Plate	3,225lbs.	
	EH20W		2" (nominal) Wood	2,480lbs.	
22'	EH22P	146-158"	3/16" Smooth Steel	3,355lbs.	560lbs.
	EH22D		3/16" Deck Plate	3,555lbs.	
	EH22W		2" (nominal) Wood	2,730lbs.	
24'	EH24P	165-192"	3/16" Smooth Steel	3,670lbs.	610lbs.
	EH24D		3/16" Deck Plate	3,880lbs.	
	EH24W		2" (nominal) Wood	2,985lbs.	

Extra Heavy-Duty Platform Construction

Structural steel channel long sills range from 7" 9.8 lbs. to 8" 11.5 lbs. Crossmembers are of structural steel channels on 12" centers. 6"-high outer rails are die-formed of 7-gauge steel. Each stake pocket is reinforced with a 10-gauge steel box welded into the side rails and will accept a 2" x 4" stake.

VERSATILE | DURABLE | RUGGED



READING HAS A FULL LINE OF TRUCK BODIES TO CHOOSE FROM ...



Classic II Service Body – Steel



Classic II Service Body – Aluminum



Classic Service Van - Aluminum



SL Service Body



Panel Body



Ready Van SL – Steel



Cranemaster 3200 Body



Platform Body



Marauder Dump Body



Redi-Dek Body



Landscaper SL Body



Redi-Rack Body



Marauder SL Dump Body



Drop Side Dump Body



Stake Body



Custom Body



— NO BODY BETTER —

All dimensions subject to plus or minus tolerance of 1/4" and all dimensions and specifications are subject to change without notice. Some items displayed in photographs are optional. Aluma-Fill, Aluma-Chock, Dual-Pro, Extend-A-Shelf, Grip-'n-Glide, Latch-Matic, Marauder, Reading, Redi-Dek, Rhino Linings, Rugged American, S.M.A.R.T Racks, Spacemaker, Tool-Mates, and TUFF STUFF are registered trademarks of The Reading Group, LLC in the United States and some foreign countries. The Reading Kangaroo is a trademarked image and may not be reproduced or used without express permission from The Reading Group.





Thank you for purchasing a Reading product.

LIMITED WARRANTY



Benefits of Registering your Reading Product:

- We maintain a record of your purchase and can assist if any questions arise
- Your feedback can drive product enhancements
- Our goal is 100% satisfaction. Should you have any concerns regarding your Reading product, a Reading representative will contact you

Made in the USA



HERE ARE YOUR KEYS AND YOUR READING BODY WARRANTY!

What is Covered Under the Reading Limited Warranty?

- Steel body manufactured after 2/16/04 – 6 years
- Hybrid bodies are covered for a period of 6 years
- Aluminum body manufactured after 6/30/08 – 10 years
- Platform, Landscaper SL, Stake Rack, Dump Bodies, Redi-Dek, Tool Boxes – 3 years
- Pick-up Caps – 5 years

Reading warrants its factory applied powder coat finish against material defects for 3 years or 36,000 miles whichever occurs first from the date of purchase.

Reading warrants its products to be free of rust-through perforation for the life of the warranty.

Reading warrants only its own products that are manufactured in its own facility for the time period outlined. Vendor-supplied components, such as locks, hinges, lights, hoists, etc, are solely covered by the vendor's explicit warranty. Reading does not extend beyond the vendor supplied warranty.

This limited warranty applies only when the product is properly installed by an Authorized Reading Truck Body installer and is properly maintained and used for the purpose for which it was designed. The warranty period begins on the date of purchase from the first owner/user or one year from the date the product was shipped from the Reading Truck Body manufacturing plant, whichever comes first.

Who Benefits from this Warranty?

The Reading obligation under this warranty applies to the first purchaser of the product of the vehicle during the warranty period.

How is a Warranty Claim Handled?

The purchaser shall immediately notify the local Authorized Distributor. The Purchaser or the Distributor can submit the claim using the form on www.readingbody.com/warranty-info/make-a-claim. The claim must include the model and serial number of the body, provide a detailed description of the problem and provide photographs of the entire unit including shots of the specified defect. All repairs must be authorized by Reading Truck Body prior to any work being completed.

If after the claim is reviewed, and Reading determines the product is defective in material or workmanship as claimed, Reading shall have the option to repair the defect or replace the product or any part. Reading shall not be liable for any rental reimbursement, loss of vehicle use, inconvenience, storage, lost time/pay, etc.

Exclusions to Warranty

1. Accessories or services not furnished by Reading, or damages/corrosions caused by these accessories or services. This includes optional parts, aftermarket products, components, installation, finish painting, lettering, wiring or modifications.
2. Specific non-rust-through and paint warranty exclusions:
 - Products which may have been used to carry corrosive materials, where such materials may result in corrosion or rust-through perforation
 - Paint warranty void if product purchased in prime paint and finished by the original owner
 - If an aftermarket liner coating is applied to the body the paint warranty will be voided due to the requirements of the liner
 - Products being warranted under the rust-through warranty must have a perforation through the metal

- Rust on a painted surface is not considered a rust-through warranty
 - Damage or corrosion caused by airborne fallout, salt from the sea air, salt or other materials used to control road conditions, chemicals, tree sap, stones, hail, earthquake, water or flood windstorm, lightning, the application of chemicals or sealants subsequent to manufacture are not covered or normal wear and tear on the product
 - Damages due to the failure to follow the recommended maintenance schedule of lubricating the hinges, locks and lock cylinders
3. Damage due to accident, misuse, abuse or alteration of the product.
 4. Fatigue cracking of the body structure caused by improper mounting, overloading, severe off-road applications, twisting loads influenced by cranes or aerial devices. The twisting exceeds the factory body twist allowance.
 5. Products purchased and used outside the United States and Canada.
 6. Products not properly maintained per maintenance instructions.
 7. Platforms only – wood floors that are found defective, in which case the replacement cost to Reading shall be limited to the following percentages:
 - 100% First year
 - 50% Second year
 - 25% Third year
 8. The SMART Racks on Reading platform bodies are covered for a period of 5 years.
 9. Translucent roofs are covered for a period of 1 year, unless misused or modified in any way.
 10. Factory bed liners are covered for a period of 1 year, unless misused or modified in any way.

Disclaimers

Reading Truck Body, LLC warrants its products only as stated in this warranty. Reading makes no other warranties, express or implied and disclaims all other warranties, including any implied warranty of merchantability or fitness for particular purpose.

Reading obligations are limited to those expressed in this warranty, and Reading shall not be liable to the purchaser or any third party for any direct or indirect, incidental or consequential damage or loss.

Some states do not allow limitations on how long an implied warranty lasts or exclusions or limitations of incidental or consequential damages so the above limitations or exclusions may not apply to you. This warranty gives you specific legal rights and you may also have other rights which may vary from state to state.

If the product is improperly installed, modified, misused, damaged or otherwise tampered with, the foregoing warranty shall lapse and become null and void.

This warranty shall be enforced and construed in accordance with the laws of Pennsylvania.

No person is authorized to modify or add to the foregoing warranty.



READING HAS A FULL LINE OF TRUCK BODIES TO CHOOSE FROM ...



Classic II Service Body – Steel and Aluminum



Classic Service Van – Aluminum



Cranemaster 3200 Body



Ready Van SL – Steel



Platform Body



Redi-Dek Body



Marauder Dump Body



Landscaper SL Body

(Some models shown with optional equipment)

HOW TO LOCATE:

Reading Serial No. - Located in the curbside horizontal compartment on the second front partition.

Key No. - The key number can be found on the side of the key. The following procedure must be followed to locate the lock key number if the keys are lost. Open any door and remove the lock cover located on the inside of the door. Locate the cylinder (which is positioned at the end of the linkage rod). The key number will be found on the flat side of the cylinder.

Sold and serviced locally by:



Preventive Maintenance – Steel Platform Bodies

- 1) **Powder Coat Maintenance** - Bodies that are equipped with powder coat paint require routine maintenance and care. This care includes periodic washing and waxing of the truckbody. The cleaners and wax, which are normally utilized on your chassis, can be used to maintain the body.

- 2) **Solvents & Cleansing Solutions** - Care must be exercised when using solvents or cleansing solutions on truck body. Read and test before applying.

- 3) **Winter Conditions** - Rinse ice and snow removal chemicals from body to prevent corrosion. NOTE: if the truck body is being used in areas where roads are chemically treated during winter months, a weekly wash of the truck body is HIGHLY RECOMMENDED.

- 4) **Lubrication** – any moving, inserting or sliding parts eg latches, posts, hinges etc apply lubrication of white lithium grease every 3- 6 months.

PICKUP LIFTS

PALFINGER

LIFETIME EXCELLENCE

A MULTI-FUNCTIONAL WORKHORSE



RELIABILITY AND VERSATILITY ARE OFFERED WITH PICKUP LIFTS IN BOTH CABLE AND DIRECT LIFT STYLES.



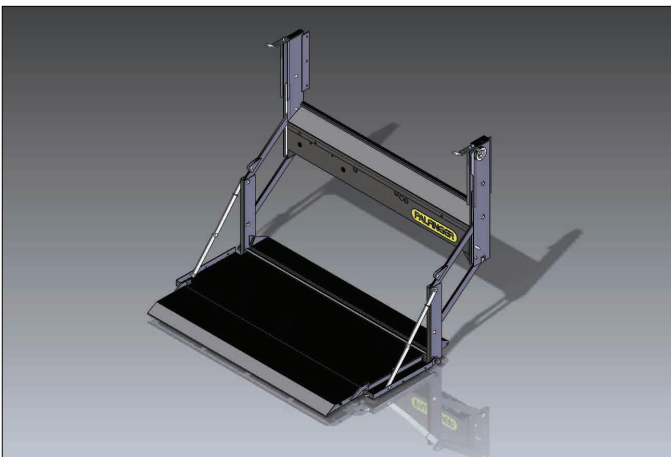

CABLE LIFT

- Serviceability - All hydraulics and key electrical connections are enclosed and protected from dirt and moisture.
- Overload protection - Built in overload protection through relief valves in hydraulic pump.
- Surge protection - Standard 150 amp circuit breaker protects chassis electronics.
- Hitch - Pickup Lift does not extend below the chassis frame, allowing for receiver-type hitch use.
- Reduced maintenance - Maintenance free bushings
- Controllability - Standard toggle switches allow for complete control of liftgate through full range of travel.

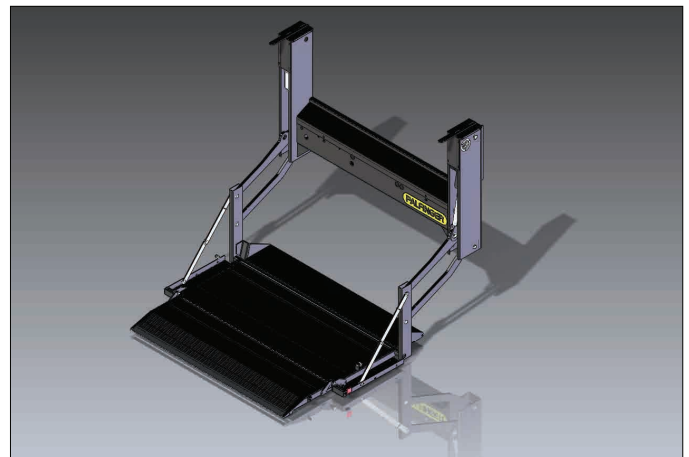

DIRECT LIFT

- Single point gate release - Dual latching passenger side single release handle that unlatches both sides of the platform.
- Lift to weight - Increased lift to weight ratio compared to similar cable liftgates.
- Ease of loading - Platform easily lowers for dock loading.
- Hitch - Pickup Lift does not extend below the chassis frame, allowing for receiver-type hitch use.
- E-Coat - Corrosion resistant protection
- Installation - Bolt on installation





PALFINGER

STANDARD FEATURES



SINGLE POINT PLATFORM RELEASE*

Dual latching passenger side single release handle that unlatches both sides of the platform



150-AMP

Factory supplied 150 amp circuit breaker to protect your liftgate and vehicle's electrical system.



WARRANTY

Industry leading 3 year warranty on power unit.



MAINTENANCE-FREE

Self-lubricating bushings at all pivot points and large pulleys for reduced cable wear.



WEATHER PROTECTION

All hydraulics and key electrical connections are enclosed and protected from dirt and moisture.



RECEIVER HITCH CLEARANCE

Pickup Lift does not extend below the chassis frame, allowing for receiver-type hitch use.

CABLE LIFTS

Application	Capacity	Model	Max Bed Height	Platform Load Area		Platform Load Area	
				Steel Treadplate	Weight	Aluminum	Weight
Service Bodies	1,000 lbs.	E38-48	40"	45" x 27" + 3" Taper	325 lbs.	45" x 38" + 4" Taper **	300 lbs.
Service Bodies	1,000 lbs.	E38-54	40"	51" x 27" + 3" Taper	360 lbs.	51" x 38" + 4" Taper **	325 lbs.
Service Bodies	1,600 lbs.	E46-64SB	46"	62" x 36" + 3" Taper	540 lbs.	52" x 38" + 4" Taper **	485 lbs.
Pickups	1,000 lbs.	E38-54	40"	52" x 36" + 3" Taper	360 lbs.	52" x 38" + 4" Taper **	325 lbs.
Pickups	1,000 lbs.	E38-60	40"	57" x 27" + 3" Taper	355 lbs.	57" x 38" + 4" Taper **	320 lbs.
Pickups	1,000 lbs.	E38-64	40"	62" x 27" + 3" Taper	350 lbs.	62" x 38" + 4" Taper **	315 lbs.
Cargo Van	1,000 lbs.	E38-60FV	40"	57" x 27" + 3" Taper	390 lbs.	57" x 38" + 4" Taper **	370 lbs.
Service Van Stake Bodies	1,000 lbs.	E38-72	40"	68" x 36" + 4" Taper	540 lbs.	68" x 38" + 4" Taper	485 lbs.
Service Van Stake Bodies	1,000 lbs.	E38-78	40"	76" x 36" + 4" Taper	580 lbs.	76" x 38" + 4" Taper	525 lbs.
Service Van Stake Bodies	1,000 lbs.	E38-86	40"	82" x 36" + 4" Taper	590 lbs.	82" x 38" + 4" Taper	530 lbs.
Service Van Stake Bodies	1,300 lbs.	E48-64	48"	62" x 34" + 4" Taper	485 lbs.	62" x 34" + 4" Taper	435 lbs.
Service Van Stake Bodies	1,300 lbs.	E48-72	48"	68" x 34" + 4" Taper	535 lbs.	68" x 34" + 4" Taper	485 lbs.
Service Van Stake Bodies	1,300 lbs.	E48-78	48"	76" x 34" + 4" Taper	625 lbs.	76" x 34" + 4" Taper	565 lbs.
Service Van Stake Bodies	1,300 lbs.	E48-86	48"	82" x 34" + 4" Taper	660 lbs.	82" x 34" + 4" Taper	595 lbs.
Service Van Stake Bodies	1,300 lbs.	E48-91	48"	86" x 34" + 4" Taper	690 lbs.	85" x 34" + 4" Taper	625 lbs.
Service Van Stake Bodies	1,600 lbs.	E50-78	50"	76" x 34" + 4" Taper	690 lbs.	76" x 34" + 4" Taper	625 lbs.
Service Van Stake Bodies	1,600 lbs.	E50-86	50"	82" x 34" + 4" Taper	710 lbs.	82" x 34" + 4" Taper	640 lbs.
Service Van Stake Bodies	1,600 lbs.	E50-91	50"	86" x 34" + 4" Taper	720 lbs.	86" x 34" + 4" Taper	650 lbs.
Dump Bodies	1,300 lbs.	E48-78DE	48"	76" x 34"	655 lbs.	76" x 34"	590 lbs.
Dump Bodies	1,300 lbs.	E48-86DE	48"	82" x 34"	665 lbs.	82" x 34"	600 lbs.
Dump Bodies	1,300 lbs.	E48-91DE	48"	86" x 34"	690 lbs.	86" x 34"	625 lbs.
Dump Bodies	1,600 lbs.	E50-78DE	50"	76" x 34"	720 lbs.	76" x 34"	650 lbs.
Dump Bodies	1,600 lbs.	E50-86DE	50"	82" x 34"	735 lbs.	82" x 34"	665 lbs.
Dump Bodies	1,600 lbs.	E50-91DE	50"	86" x 34"	740 lbs.	86" x 34"	670 lbs.

Note (**): Extruded aluminum

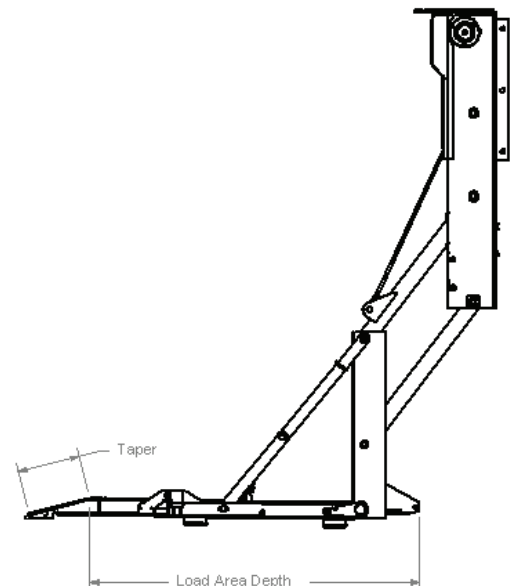
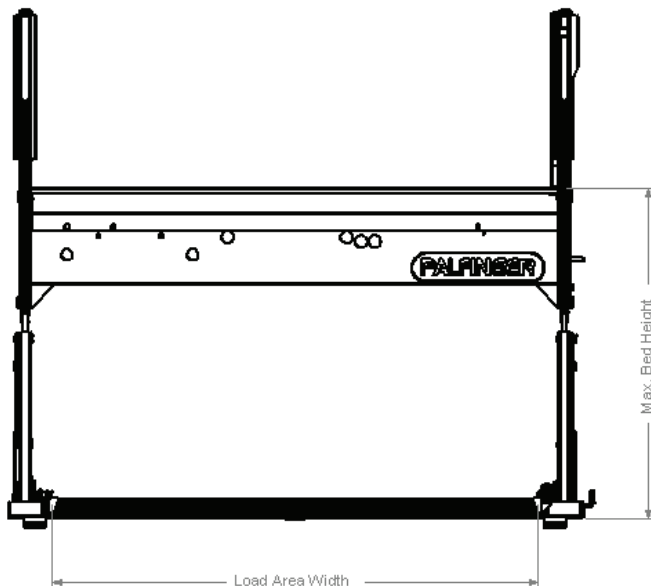

POPULAR OPTIONS

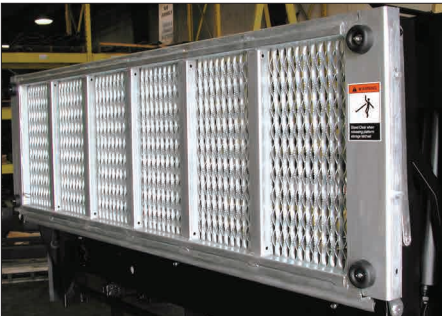

ZINC ELECTROPLATING

Zinc plating is affordable, durable and offers excellent corrosion resistance, combined with a bright and attractive finish. Safety grate option shown.



RHINO LININGS' TUFFSTUFF®

Sprayed-on tuff Stuff® polyurethane provides a durable watertight and airtight bond with the surface of your platform.

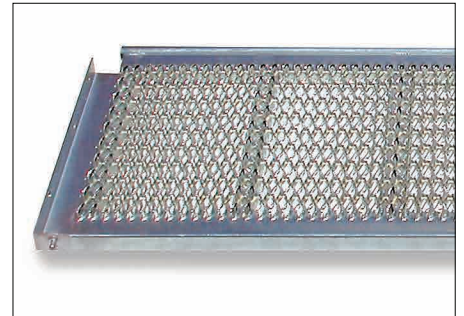

GRIP STRUT® PLATFORM

Safety grated airflow platform, ideal for tire bodies.



WIRED REMOTE

Remote push-button control with seven foot cord.

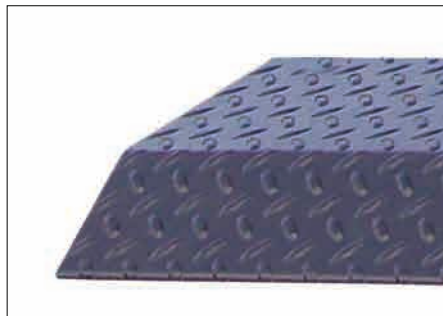

FOLD-OUT EXTENSION - 38" & EDL

This converts the 27" to a 36" deep platform on the 38" series & converts the 30" to a 39" deep platform on the EDL series.



LIGHTING

L-3 Light kit
• 2 brackets
• 6 lights

L-2 Light kit
• 2 brackets
• 4 lights

E-COAT PROTECTION



Every Pickup Lift is cleaned in a series of four baths then pre-treated with a phosphate conversion coating to prepare the lift for electro coating.



After the zinc bath, the Pickup Lift is fully immersed in a high gloss black acrylic paint bath where direct current is applied between the steel and counter electrodes.



Once painted, the Pickup Lift is rinsed to recycle any undeposited paint, achieving nearly 100% paint efficiency for an environmentally friendly process.



VENDOR CUSTOMER CODE	SUPPLIER PART NUMBER	SUPPLIER NAME	MANUFACTURER NAME	MANUFACTURER PART NUMBER	COMMODITY CODE	ITEM DESCRIPTION	EXTENDED DESCRIPTION	UNIT OF MEASURE	LIST PRICE	DELIVERY DAYS
VS0000000040	H14W	Hews Company			06500	Reading Heavy Duty 14' Platform Body	Body Only	EA	\$4,945.00	120
VS0000000040	LABOR	Hews Company			06500	Labor to install Body, Bumper, Hitch & Delivery	Select when ordering body	EA	\$2,240.00	120
VS0000000040	E50-91	Hews Company			06500	Palfinger Liftgate-Installed	Compatible with Hoist	EA	\$3,555.00	120
VS0000000040	519DAE	Hews Company			06500	Omaha Hydraulic Hoist-Installed	n/a	EA	\$3,465.00	120
VS0000000040	READING GATE	Hews Company			06500	Reading Swing Gate	Bolt-on Corner Posts	EA	\$655.00	120
VS0000000040	EZ Step 3-Rung	Hews Company			06500	Step System	n/a	EA	\$400.00	120

STATE OF MAINE

GENERAL TERMS AND CONDITIONS FOR GOODS AND/OR SERVICES UNDER BUYER PURCHASE ORDERS (BPOs) AND MASTER AGREEMENTS (MAs)

1. **DEFINITIONS:** The following definitions are applicable to these standard terms and conditions:
 - a. The term “Buyer” or “State” shall refer to the Government of the State of Maine or a person representing the Government of the State of Maine.
 - b. The term “Department” or “DAFS” shall refer to the State of Maine Department of Administrative and Financial Services.
 - c. The term “Bureau” or “BGS” shall refer to the State of Maine Bureau of General Services.
 - d. The term “Division” shall refer to the State of Maine Division of Purchases.
 - e. The term “Contractor”, “Vendor”, or “Provider” shall refer to the organization that is providing goods and/or services through the contract to which these standard terms and conditions have been attached and incorporated.
 - f. The term “Contract” or “Agreement” shall refer to the contract document to which these standard terms and conditions apply, taking the format of a Buyer Purchase Order (BPO) or Master Agreement (MA) or other contractual document that is mutually agreed upon between the State and the Contractor.

2. **WARRANTY:** The Contractor warrants the following:
 - a. That all goods and services to be supplied by it under this Contract are fit and sufficient for the purpose intended, and
 - b. That all goods and services covered by this Contract will conform to the specifications, drawing samples, symbols or other description specified by the Division, and
 - c. That such articles are merchantable, good quality, and free from defects whether patent or latent in material and workmanship, and
 - d. That all workmanship, materials, and articles to be provided are of the best grade and quality, and
 - e. That it has good and clear title to all articles to be supplied by it and the same are free and clear from all liens, encumbrances and security interest.

Neither the final certificate of payment nor any provision herein, nor partial nor entire use of the articles provided shall constitute an acceptance of work not done in accordance with this agreement or relieve the Contractor liability in respect of any warranties or responsibility for faulty material or workmanship. The Contractor shall remedy any defects in the work and pay any damage to other work resulting therefrom, which shall appear within one year from the date of final acceptance of the work provided hereunder. The Division of Purchases shall give written notice of observed defects with reasonable promptness.

3. **TAXES:** Contractor agrees that, unless otherwise indicated in the order, the prices herein do not include federal, state, or local sales or use tax from which an exemption is available for purposes of this order. Contractor agrees to accept and use tax exemption certificates when supplied by the Division as applicable. In case it shall ever be determined that any tax included in the prices herein was not required to be paid by Contractor, Contractor agrees to notify the Division and to make prompt application for the refund thereof, to take all proper steps to procure the same and when received to pay the same to the Division.

4. **PACKING AND SHIPMENT:** Deliveries shall be made as specified without charge for boxing, carting, or storage, unless otherwise specified. Articles shall be suitably packed to secure lowest

transportation cost and to conform to the requirements of common carriers and any applicable specifications. Order numbers and symbols must be plainly marked on all invoices, packages, bills of lading, and shipping orders. Bill of lading should accompany each invoice. Count or weight shall be final and conclusive on shipments not accompanied by packing lists.

5. DELIVERY: Delivery should be strictly in accordance with delivery schedule. If Contractor's deliveries fail to meet such schedule, the Division, without limiting its other remedies, may direct expedited routing and the difference between the expedited routing and the order routing costs shall be paid by the Contractor. Articles fabricated beyond the Division's releases are at Contractor's risk. Contractor shall not make material commitments or production arrangements in excess of the amount or in advance of the time necessary to meet delivery schedule, and, unless otherwise specified herein, no deliveries shall be made in advance of the Division's delivery schedule. Neither party shall be liable for excess costs of deliveries or defaults due to the causes beyond its control and without its fault or negligence, provided, however, that when the Contractor has reason to believe that the deliveries will not be made as scheduled, written notice setting forth the cause of the anticipated delay will be given immediately to the Division. If the Contractor's delay or default is caused by the delay or default of a subcontractor, such delay or default shall be excusable only if it arose out of causes beyond the control of both Contractor and subcontractor and without fault of negligence or either of them and the articles or services to be furnished were not obtainable from other sources in sufficient time to permit Contractor to meet the required delivery schedule.

6. FORCE MAJEURE: The State may, at its discretion, excuse the performance of an obligation by a party under this Agreement in the event that performance of that obligation by that party is prevented by an act of God, act of war, riot, fire, explosion, flood or other catastrophe, sabotage, severe shortage of fuel, power or raw materials, change in law, court order, national defense requirement, or strike or labor dispute, provided that any such event and the delay caused thereby is beyond the control of, and could not reasonably be avoided by, that party. The State may, at its discretion, extend the time period for performance of the obligation excused under this section by the period of the excused delay together with a reasonable period to reinstate compliance with the terms of this Agreement.

7. INSPECTION: All articles and work will be subject to final inspection and approval after delivery, notwithstanding prior payment, it being expressly agreed that payment will not constitute final acceptance. The Division of Purchases, at its option, may either reject any article or work not in conformity with the requirements and terms of this order, or re-work the same at Contractor's expense. The Division may reject the entire shipment where it consists of a quantity of similar articles and sample inspection discloses that ten (10%) percent of the articles inspected are defective, unless Contractor agrees to reimburse the Division for the cost of a complete inspection of the articles included in such shipment. Rejected material may be returned at Contractor's risk and expense at the full invoice price plus applicable incoming transportation charges, if any. No replacement of defective articles of work shall be made unless specified by the Division.

8. INVOICE: The original and duplicate invoices covering each and every shipment made against this order showing Contract number, Vendor number, and other essential particulars, must be forwarded promptly to the ordering agency concerned by the Vendor to whom the order is issued. Delays in receiving invoice and also errors and omissions on statements will be considered just cause for withholding settlement without losing discount privileges. All accounts are to be carried in the name of the agency or institution receiving the goods, and not in the name of the Division of Purchases.

9. ALTERATIONS: The Division reserves the right to increase or decrease all or any portion of the work and the articles required by the bidding documents or this agreements, or to eliminate all or any portion of such work or articles or to change delivery date hereon without invalidating this Agreement. All such alterations shall be in writing. If any such alterations are made, the contract amount or amounts shall be adjusted accordingly. In no event shall Contractor fail or refuse to continue the performance of the work in providing of articles under this Agreement because of the inability of the parties to agree on an adjustment or adjustments.

10. TERMINATION: The Division may terminate the whole or any part of this Agreement in any one of the following circumstances:

- a. The Contractor fails to make delivery of articles, or to perform services within the time or times specified herein, or
- b. If Contractor fails to deliver specified materials or services, or
- c. If Contractor fails to perform any of the provisions of this Agreement, or
- d. If Contractor so fails to make progress as to endanger the performance of this Agreement in accordance with its terms, or
- e. If Contractor is adjudged bankrupt, or if it makes a general assignment for the benefit of its creditors or if a receiver is appointed on account of its insolvency, or
- f. Whenever for any reason the State shall determine that such termination is in the best interest of the State to do so.

In the event that the Division terminates this Agreement in whole or in part, pursuant to this paragraph with the exception of 8(f), the Division may procure (articles and services similar to those so terminated) upon such terms and in such manner as the Division deems appropriate, and Contractor shall be liable to the Division for any excess cost of such similar articles or services.

11. NON-APPROPRIATION: Notwithstanding any other provision of this Agreement, if the State does not receive sufficient funds to fund this Agreement and other obligations of the State, if funds are de-appropriated, or if the State does not receive legal authority to expend funds from the Maine State Legislature or Maine courts, then the State is not obligated to make payment under this Agreement.

12. COMPLIANCE WITH APPLICABLE LAWS: Contractor agrees that, in the performance hereof, it will comply with applicable laws, including, but not limited to statutes, rules, regulations or orders of the United States Government or of any state or political subdivision(s) thereof, and the same shall be deemed incorporated herein by reference. Awarding agency requirements and regulations pertaining to copyrights and rights in data. Access by the grantee, the subgrantee, the Federal grantor agency, the Comptroller General of the United States, or any of their duly authorized representatives to any books, documents, papers and records of the Contractor which are directly pertinent to that specific contract for the purpose of making audit, examination, excerpts, and transcriptions. Retention of all required records for three years after grantees or subgrantees make final payments and all other pending matters are closed. Compliance with all applicable standards, orders, or requirements issued under section 306 of the Clean Air Act (42 U.S.C. 1857(h), section 508 of the Clean Water Act, (33 U.S.C. 1368), Executive Order 11738, and Environmental Protection Agency regulations (40 CFR part 15). (Contracts, subcontracts, and subgrants of amounts in excess of \$100,000). Mandatory standards and policies relating to energy efficiency which are

contained in the state energy conservation plan issued in compliance with Energy Policy and Conservation Act (Pub. L. 94-163, 89 Stat. 871).

13. INTERPRETATION: This Agreement shall be governed by the laws of the State of Maine as to interpretation and performance.

14. DISPUTES: The Division will decide any and all questions which may arise as to the quality and acceptability of articles provided and installation of such articles, and as to the manner of performance and rate of progress under this Contract. The Division will decide all questions, which may arise as to the interpretation of the terms of this Agreement and the fulfillment of this Agreement on the part of the Contractor.

15. ASSIGNMENT: None of the sums due or to become due nor any of the work to be performed under this order shall be assigned nor shall Contractor subcontract for completed or substantially completed articles called for by this order without the Division's prior written consent. No subcontract or transfer of agreement shall in any case release the Contractor of its obligations and liabilities under this Agreement.

16. STATE HELD HARMLESS: The Contractor agrees to indemnify, defend, and save harmless the State, its officers, agents, and employees from any and all claims and losses accruing or resulting to any and all contractors, subcontractors, material men, laborers and other persons, firm or corporation furnishing or supplying work, services, articles, or supplies in connection with the performance of this Agreement, and from any and all claims and losses accruing or resulting to any person, firm or corporation who may be injured or damaged by the Contractor in the performance of this Agreement.

17. SOLICITATION: The Contractor warrants that it has not employed or written any company or person, other than a bona fide employee working solely for the Contractor to solicit or secure this Agreement, and it has not paid, or agreed to pay any company, or person, other than a bona fide employee working solely for the Contractor any fee, commission, percentage, brokerage fee, gifts, or any other consideration, contingent upon, or resulting from the award for making this Agreement. For breach or violation of this warranty, the Division shall have the absolute right to annul this agreement or, in its discretion, to deduct from the Agreement price or consideration, or otherwise recover the full amount of such fee, commission, percentage, brokerage fee, gifts, or contingent fee.

18. WAIVER: The failure of the Division to insist, in any one or more instances, upon the performance of any of the terms, covenants, or conditions of this order or to exercise any right hereunder, shall not be construed as a waiver or relinquishment of the future performance of any such term, covenant, or condition or the future exercise of such right, but the obligation of Contractor with respect to such future performance shall continue in full force and effect.

19. MATERIAL SAFETY: All manufacturers, importers, suppliers, or distributors of hazardous chemicals doing business in this State must provide a copy of the current Material Safety Data Sheet (MSDS) for any hazardous chemical to their direct purchasers of that chemical.

20. COMPETITION: By accepting this Contract, Contractor agrees that no collusion or other restraint of free competitive bidding, either directly or indirectly, has occurred in connection with this award by the Division of Purchases.

21. INTEGRATION: All terms of this Contract are to be interpreted in such a way as to be consistent at all times with this Standard Terms and Conditions document, and this document shall take precedence over any other terms, conditions, or provisions incorporated into the Contract.