

MA 18P 1912020000000000073
NEW

State of Maine



Master Agreement

Effective Date: 12/02/19

Expiration Date: 12/31/20

Master Agreement Description: Platform Stake Body, 112" L x 96" W w/Options

Buyer Information

William Allen 207-624-7871 ext. NULL WJE.Allen@maine.gov

Issuer Information

Jessica Norton 207-624-8226 ext. Jessica.h.norton@MAINE.GOV

Requestor Information

Jessica Norton 207-624-8226 ext. Jessica.h.norton@MAINE.GOV

Agreement Reporting Categories

Authorized Departments

Vendor Information

Vendor Line #: 1

Vendor ID

VS0000000040

Vendor Name

Hews Company, LLC

Alias/DBA

Vendor Address Information

190 Rumery Street

South Portland, ME 04106

US

Vendor Contact Information

Katy Hews
207-767-2136 ext. 121
khews@hewesco.com

Payment Discount Terms

Discount 1: 1.0000% 30 **Days**
0 **Days**
0 **Days**
0 **Days**

Commodity Information

Vendor Line #: 1

Vendor Name: Hews Company, LLC

Commodity Line #: 1

Commodity Code: 06500

Commodity Description: Platform Stake Body, 112" L x 96" W w/Options

Commodity Specifications:

Commodity Extended Description: Platform Stake Body, 112" L x 96" W w/Options

Quantity	UOM	Unit Price
0.00000		0.000000
Delivery Days	Free On Board	
0		
Contract Amount	Service Start Date	Service End Date
0.00		
Catalog Name	Discount	
PLATFORM BODIES	0.0000 %	
	Discount Start Date	Discount End Date
	12/02/19	12/31/20

Please see authorized signatures displayed on the next page

Each signatory below represents that the person has the requisite authority to enter into this Contract.
The parties sign and cause this Contract to be executed.

State of Maine - Department of Administrative and Financial Services

DocuSigned by:
Jaime C. Schorr 12/2/2019
8D6427754DD0450
Signature Date

Jaime C. Schorr, Chief Procurement Officer

Vendor Hews Company LLC

DocuSigned by:
Robert Hews 12/2/2019
8D4347345ED0444...
Signature Date

Robert Hews President
Print Representative Name and Title

RIDERS

<input checked="" type="checkbox"/>	The following riders are hereby incorporated into this Contract and made part of it by reference: (check all that apply)
<input checked="" type="checkbox"/>	Rider A – Scope of Work and/or Specifications
<input checked="" type="checkbox"/>	Rider B – Terms and Conditions
<input type="checkbox"/>	Rider C - Exceptions
<input checked="" type="checkbox"/>	Bid Cover Page and Debarment Form – RFQ 17D 191105-148 Appendix A
<input checked="" type="checkbox"/>	Municipality Political Subdivision and School District Participation Certification – RFQ 17D 191105-148 Appendix D
<input checked="" type="checkbox"/>	Price sheet
<input checked="" type="checkbox"/>	RFQ 17D 191105-148 Appendix E, Certifications and Appendix F, MaineDOT Terms and Conditions

RIDER A
Scope of Work and/or Specifications
MA 18P 1912020000000000073

Originating RFQ: 17D 191105-148

Commodity: Platform Stake Body, 112" L x 96" W w/Options

Contract Period: Through December 31, 2020. The State of Maine can opt to issue up to two (2) one (1) year extensions.

Contact Person: The contact person will help consumers place orders, inquire about orders that have not been delivered, all shipping issues, quality issues, and any issues pertaining to this Master Agreement. All orders not submitted through a DO will be sent through the contractor's contact person. **The contact person will be: Dave Gain Tel: 207-767-2136**
Email: dgain@hewesco.com

Extension of Contract: The Director of Procurement Services may, with the consent of the contractor extend the Contract period beyond the indicated expiration date.

Cancellation of Contract: The Division of Procurement Services reserves the right to cancel a contract with a thirty-day written notice OR cancel immediately if the contractor does not conform to terms and conditions and specifications of contract.

Prices: Prices shown are with shipping terms of "Free on Board (FOB) – Destination". The State intends for this to mean that all goods are priced to include shipping charges, if any, to the State's desired location. The "FOB – Destination" shipping term is also intended to mean that the State shall not bear any responsibility for the goods in question until the State takes possession of them at the destination point of delivery. Prices are to remain firm for the duration of the contract.

Quantities: It is understood and agreed that the contract will cover the **actual quantities** required by State Agency over the length of the contract.

Ordering Procedure: Delivery orders (DO) will be created in AdvantageME for all orders over \$5000.00. If a DO is used, the DO will be e-mailed to the email address set up in AdvantageME by the Vendor as a .pdf file. Orders less than \$5000.00 can be ordered using a P-Card.

Appendix B – Specifications

INSTRUCTIONS FOR COMPLETING TECHNICAL SPECIFICATION SHEET

Please complete the checklist for technical specifications set forth below. **Electronically enter responses directly into the text-enabled fields next to each specification, including actual dimensions when applicable.** Each Bidder must indicate whether it can meet the technical specifications by inserting an “X” next to each specification. The “X” will demonstrate that the Bidder’s offering meets the technical specification. If a Bidder cannot meet a technical specification, then the Bidder must give an explanation for each exception and for equipment that is not available or that will be dealer installed. All explanations must be provided in detail on separate pages along with the justification as to why the alternative equipment or deliverables will be as good as the equipment or deliverables described in the detailed specifications for desired items. A copy of the vendor specification proposal must be provided. Following these instructions is essential for proper bid evaluation.

If a Bidder fails to provide requested information or if information on a quote is found to be false or misleading, the quote will be rejected as unresponsive. The award will be made on a best value basis to the vendor that **either meets or most closely meets** the specifications, while taking price and delivery into consideration.

The following abbreviations must be used:

X	Standard or as specified
N/A	Not Available
DI	Dealer Installed
AE	Approved Equal

	1.0 CONSTRUCTION	Abbreviation	Actual Dimension	Notes
1.1	Endrails and side rails shall be a minimum of 5 5/8” 12ga. high strength steel.	X		
1.2	Crossmembers shall be a minimum of 4-inch 11 ga. high strength “C” channel.	X	3.5”/10 GA	Meets Structural Requirements
1.3	Crossmember spacing shall be a minimum of every 24 inches.	X	16” O/C	Exceeds
1.4	Gussets shall be front and rear rails along with every other crossmember.	X		
1.5	Long sills shall be a minimum of 4-inch 10ga. formed channel and installed with a	X	5” 10 GA; 112” LENGTH	112” Long Sills fit body length

	minimum of 34-inch spacing, minimum length shall be 116".			
1.6	Flooring shall be 2-inch x 6-inch tongue and groove treated dense pine.	A/E	1.5" X 4.75"	P/T Yellow Pine
1.7	Lights shall be LED and recessed mounted in shock-resistant rubber grommets and loom protected wires.	X		
1.8	Stake pockets shall be a minimum of 1.5 inch x 3.50 inch reinforced on 24-inch centers.	X	2" X 4" ON 24"	Exceeds
1.9	Stake racks shall be a minimum of 40 inches high.	X	42"	Exceeds
1.10	Stakes shall be made from a minimum of 14ga. galvanneal steel.	X	11 GA	Exceeds
1.11	Slats shall be made from a minimum of 16ga. steel and roll formed.	X	14 GA	Exceeds
1.12	Attaching hardware shall be spring loaded, anti-rattle, heavy duty hardware.	X		
1.13	Bulkhead shall be rectangular drop in 40 inches high and 96 inches wide with Hole Punched or Mesh center window.	X	42"	
1.14	Bulkhead shall have minimum 12" reinforced Cab Plate to support accessories such as Ladders and Emergency Lights - 12" footprint, flat on top.	X		
1.15	Bulkhead shall be welded or bolted in place to the front rub rail. (Bolt heads shall be facing in the body.)	X		
1.16	Hitch shall be a class V, rated up to 17,000 lbs. gross trailer weight, (Buyers # 1809055) with 7-prong Round pin trailer plug-in (See Wire Diagram). RV plugs will not be accepted.	X		

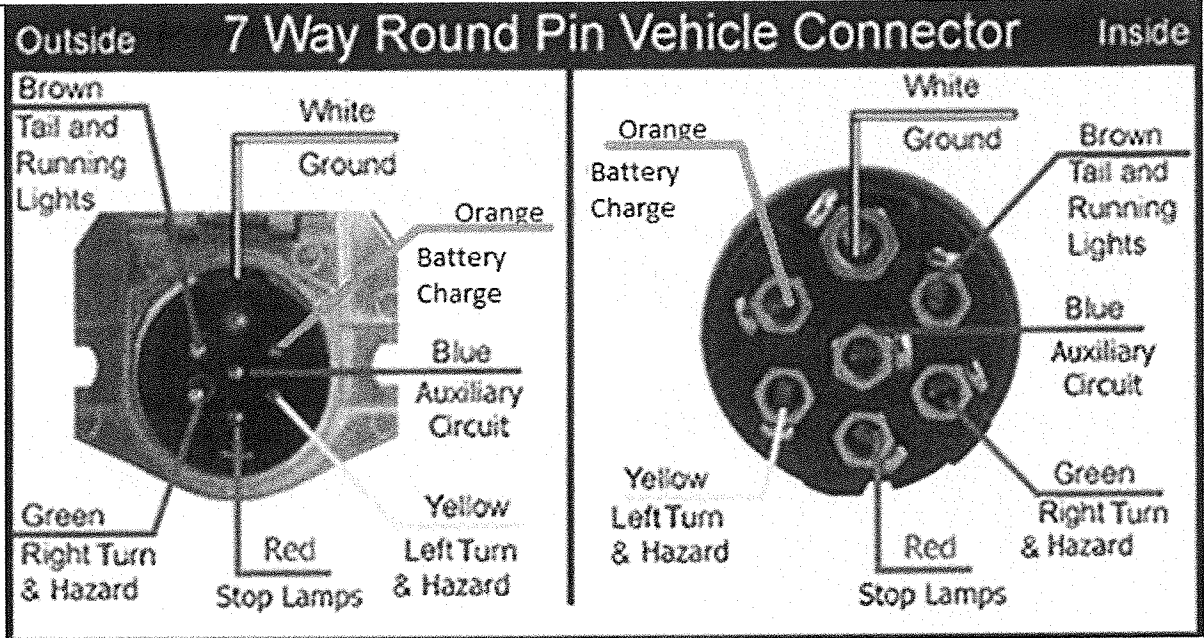

1.17	Tail lights shall be bolted on, not welded .	X	
1.18	All components shall be E-Coat priming and corrosion protection.	A/E	Polyester Powder Coat is the same process as E-Coat
1.19	All terminals, ground and power shall have anti corrosion spray.	X	
1.20	Fuel/DEF full hoses shall have hose clamps not wire ties. (Both Ends)	X	
1.21	No wiring shall run through the stake pockets or an area where it can be pinched.	X	
1.22	All exterior trailer wiring shall be professionally installed and run in suitable weather resistant loom or conduit (professionally secured).	X	
1.23	All wire splices/connectors (if applicable) shall be shrink tube barrel type or soldered and shall be sealed with weather-proof automotive type shrink tubing, Scotch lock type (wire piercing) connectors are not acceptable in any application.	X	

1.24	Hitch shall use a minimum 2 square receiver opening.	X		
1.25	Hitch shall attach to the vehicle frame only.	X		
	2.0 WARRANTY	Abbreviation	Actual Dimension	Notes
2.1	Manufacturer's standard warranty will apply.	X	3 YEARS	
2.2	Terms and conditions of warranty must be provided with bid proposal.	X		
2.3	Manufacturer's warranty will start with the in-service date.	X		
	3.0 GENERAL	Abbreviation	Actual Dimension	Notes
3.1	Bid price of body shall include mounting and all hardware to install on latest model Ford F350 with a 60-inch CA with dual wheels and delivery to MaineDOT Fleet Services at 66 Industrial Drive, Augusta, ME.	X		
3.2	Body and all components shall be black in color.	X		
3.3	Be it known that these specifications are a minimum and that bids will be evaluated based on price, warranty, manufacturer's performance data, delivery schedule, parts availability and other items deemed appropriate.	X		
3.4	Bidders are required to provide sufficient information with their bid such as manufacturer's brochures, specification sheet, etc. and to certify that they have service facilities in Maine, staffed with trained service technicians and stocked with repair parts for the equipment which is bid. Failure to provide this information may	X		

	cause the bid to be rejected. MaineDOT reserves the right to reject any and all bids.			
3.5	Body must comply with the Department of Transportation Federal Motor Vehicle Safety Standards and Department of Labor Occupational Safety and Health Standards. Lighting equipment shall meet FMVSS # 108.	X		
3.6	Exceptions to specifications shall be listed on a separate paper and noted as exceptions and submitted with bid proposal. If exceptions are not listed as such, it shall be considered that the vendor will comply with all specifications as listed.	X		SEE ATTACHED EXCEPTIONS SHEET
3.7	Backup alarm conforming to SAEJ 994 and OSHA requirements.	X		
OPTIONS				
	4.0 LIFT GATE	Abbreviation	Actual Dimension	Notes
4.1	Lift gate shall have a minimum capacity of 1,600 Lbs.	X		
4.2	Lift gate shall be a minimum of 82 inches wide and 30 inches in height.	X		
4.3	Lift gate shall have torsion spring assist fold/close.	X		
4.4	Lift gate shall include safety latch for transit.	X		
4.5	Lift gate shall have chrome cylinder rod and adjustable clevis.	X		
4.6	Power source for controlling the movement of the lift gate shall be a 12-volt self-contained hydraulic pump with resettable breakers neatly installed.	X		
4.7	Lift gate shall conform to fit rack body specifications above (both dumping & non-dumping).	X		

4.8	Lift gate and components shall be black in color.	X		
5.0 STEP		Abbreviation	Actual Dimension	Notes
5.1	Step shall be a pull-out and flip-down type with a minimum weight capacity of 350 Lbs.	X	400 LBS	Exceeds
5.2	Step shall have a minimum of two (2) rungs spaced no more than 12 inches apart.	X	3 RUNGS	Exceeds
5.3	Step shall be a minimum of 11 inches in width.	X	14.5"	Exceeds
5.4	Step shall be stored within or under the body frame and have a mechanism to prevent losses of step while the vehicle is in motion.	X		
5.5	Step shall have a grip surface to provide for maximum traction.	X		
5.6	Ladder will be located at the right rear corner of the body facing the rear.	X		
6.0 SWING GATE		Abbreviation	Actual Dimension	Notes
6.1	Swing Gate shall be galvanized steel posts and slats; rear swing gates with heavy-duty bolt-on hinge assemblies.	X		
7.0 BODY HYDRAULIC HOIST		Abbreviation	Actual Dimension	Notes
7.1	Hydraulic hoist shall have a minimum 6-ton capacity with integral safety prop.	X	7.7 TON	Exceeds
7.2	Power source for controlling the movement of the hydraulic hoist dump shall be a 12-volt self-contained hydraulic pump with resettable breakers neatly installed.	X		
7.3	Dump/Hoist assembly shall be of lowest type mounting available but should not preclude a sub frame if necessary.	X		

7.4	Body support, permanently attached, capable of being locked in place or a stop to hold body support in the up position.	X		
7.5	Power up and down.	X		
7.6	Body longitudinal must not be cut to accommodate the hoist assembly.	X		
BODY PRICE (information required)				
Body Make & Model Number: READING H9W				
\$ 5,325.00 each				
INSTALLED OPTIONS (additional costs)				
	Installed Option	Model	Price	Notes
9.1	Lift Gate System	MAXON	\$ 3,025.00 each	INSTALLED
9.2	Step System	EZ STEP	\$ 400.00 each	INSTALLED
9.3	Swing Gate	READING	\$ 340.00 each	INSTALLED
9.4	Hydraulic Hoist	READING SUBFRAME CLASS 40/D	\$ 3,715.00 each	INSTALLED
9.5	Labor to install complete body, bumper, hitch and delivery		\$ 1,530.00	



— NO BODY BETTER —

PLATFORM BODIES

HEAVY-DUTY SERIES

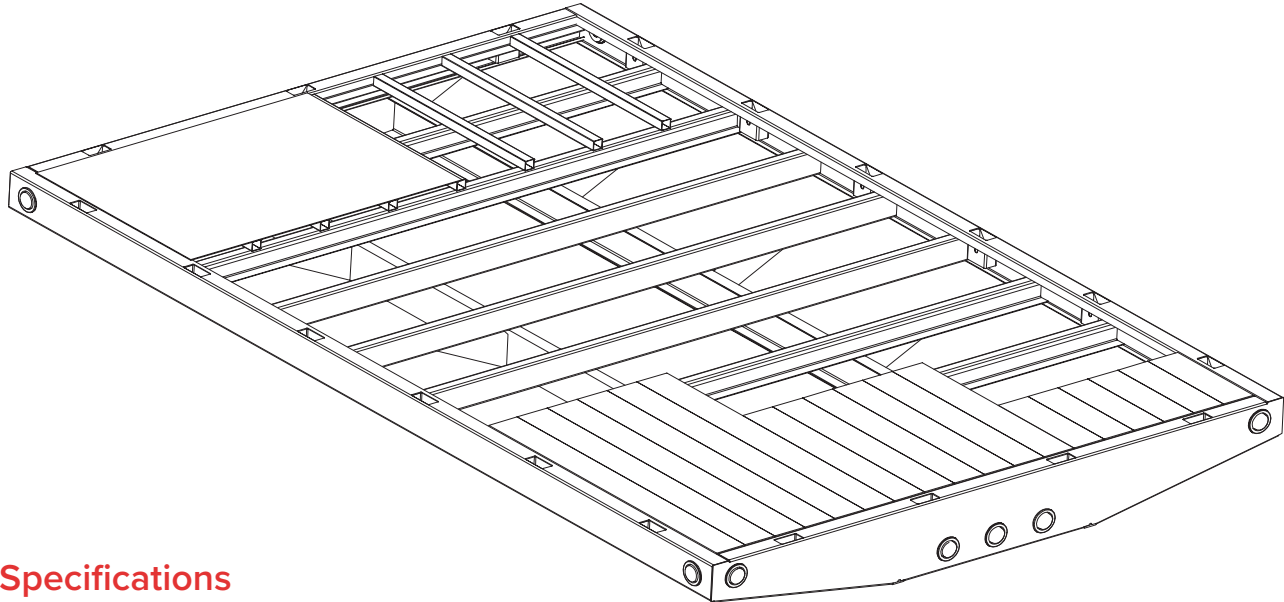

New Specifications

- Lengths range from 9'4" to 20'4"
- Standard 96" width
- Standard floor types:
 - wood (pressure-treated yellow pine)
 - smooth steel (10-gauge)
 - deckplate (12-gauge)
 - smooth steel & wood overlay
 - deckplate & wood overlay
- Long sills are structural channel (5" height on H9–H10 models, 6" on H12–H16, 7" on H18, and 9" on H20)
- Crossmembers are 10-gauge on 16" centers (with optional upgrade to 12" centers)
- All platforms are polyester powder-coated to a 90% gloss black finish
- Platform sides include 12-gauge rub rails with internal 2x4 stake pockets on 24" centers
- Drop-in bulkheads available with 42" and 52" heights
- 100% LED lighting
- Hoist Compatible - no modifications necessary to platform understructure

* Always observe GVWR, GAWR, GCWR and legal limits.

Stake Racks

- Matching stake racks are optionally available for all lengths
- Stake racks are manufactured with galvanneal-coated steel, powder-coated 90% gloss black
- Rack sets include all hardware & stake locking mechanism
- Rack sets include sides & rear racks only
- Optional adapter is available for converting rear racks to swing-out style operation

Upgraded Subframe Hoist (optional)

- Upgraded NTEA Class 40/D hoist achieves 7.7 - 14.1 Ton of rated lift capacity
- Pre-assembled to sub-frame for quick install
- Double-acting electric/hydraulic hoist with 5.5" cylinder, 2" rod and 16" stroke
- 50° maximum lift angle
- Integrated body prop included



A product of the USA



HEAVY-DUTY SERIES CONFIGURATIONS

Now available to order

Heavy-Duty Platforms						
Length	Structural Long sills	Floor Type / Model			Overlay Type / Model	
		Yellow Pine	10ga Smooth	12ga Deckplate	10ga Smooth Over Pine	12ga Deckplate Over Pine
9'4"	5"	H9W	H9P	H9D	H9POL	H9DOL
10'4"	5"	H10W	H10P	H10D	H10POL	H10DOL
12'4"	6"	H12W	H12P	H12D	H12POL	H12DOL
14'4"	6"	H14W	H14P	H14D	H14POL	H14DOL
16'4"	6"	H16W	H16P	H16D	H16POL	H16DOL
18'4"	7"	H18W	H18P	H18D	H18POL	H18DOL
20'4"	9"	H20W	H20P	H20D	H20POL	H20DOL

* Lengths above 20': Recommend Extra Heavy-Duty platforms

LINE DRAWINGS

Top View

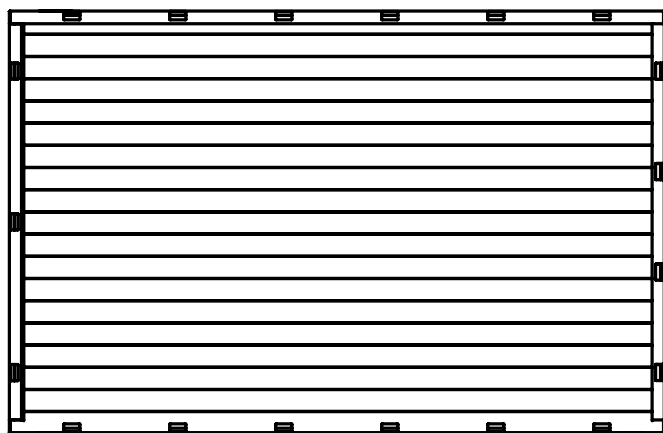

Bulkhead

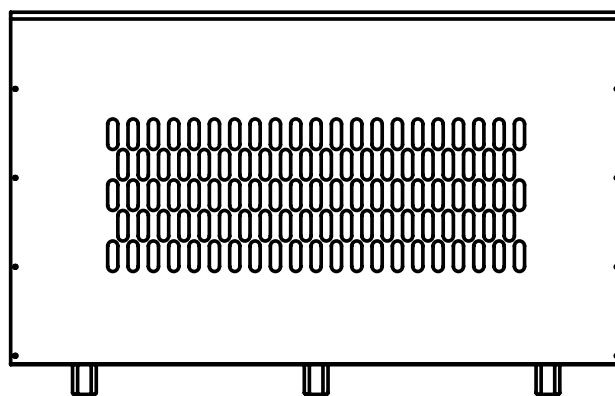

Side View

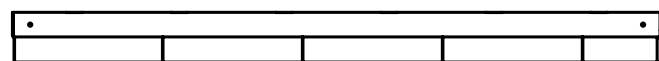

Rear View

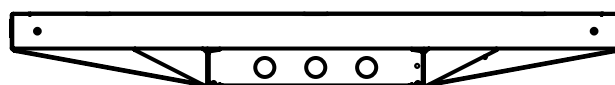

Sold and Serviced Locally by

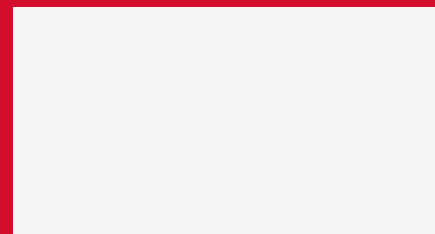

All dimensions subject to plus or minus tolerance of 1/4" and all dimensions and all specifications are subject to change without notice. Some items displayed in photographs are optional. Aluma-Fill, Aluma-Chock, Dual-Pro, Extend-A-Shelf, Grip-n-Glide, Latch-Matic, Marauder, Reading, Redi-Dek, Spacemaker, Tool-Mates, and are registered trademarks of Reading Truck Body, LLC in the United States and some foreign countries. The Reading Kangaroo is a trademarked image and may not be reproduced or used without express permission from Reading Truck Group.



Thank you for purchasing a Reading product.

LIMITED WARRANTY



Benefits of Registering your Reading Product:

- We maintain a record of your purchase and can assist if any questions arise
- Your feedback can drive product enhancements
- Our goal is 100% satisfaction. Should you have any concerns regarding your Reading product, a Reading representative will contact you



HERE ARE YOUR KEYS AND YOUR READING BODY WARRANTY!

What is Covered Under the Reading Limited Warranty?

- Steel body manufactured after 2/16/04 – 6 years
- Hybrid bodies are covered for a period of 6 years
- Aluminum body manufactured after 6/30/08 – 10 years
- Platform, Landscaper SL, Stake Rack, Dump Bodies, Redi-Dek, Tool Boxes – 3 years
- Pick-up Caps – 5 years

Reading warrants its factory applied powder coat finish against material defects for 3 years or 36,000 miles whichever occurs first from the date of purchase.

Reading warrants its products to be free of rust-through perforation for the life of the warranty.

Reading warrants only its own products that are manufactured in its own facility for the time period outlined. Vendor-supplied components, such as locks, hinges, lights, hoists, etc, are solely covered by the vendor's explicit warranty. Reading does not extend beyond the vendor supplied warranty.

This limited warranty applies only when the product is properly installed by an Authorized Reading Truck Body installer and is properly maintained and used for the purpose for which it was designed. The warranty period begins on the date of purchase from the first owner/user or one year from the date the product was shipped from the Reading Truck Body manufacturing plant, whichever comes first.

Who Benefits from this Warranty?

The Reading obligation under this warranty applies to the first purchaser of the product of the vehicle during the warranty period.

How is a Warranty Claim Handled?

The purchaser shall immediately notify the local Authorized Distributor. The Purchaser or the Distributor can submit the claim using the form on www.readingbody.com/warranty-info/make-a-claim. The claim must include the model and serial number of the body, provide a detailed description of the problem and provide photographs of the entire unit including shots of the specified defect. All repairs must be authorized by Reading Truck Body prior to any work being completed.

If after the claim is reviewed, and Reading determines the product is defective in material or workmanship as claimed, Reading shall have the option to repair the defect or replace the product or any part. Reading shall not be liable for any rental reimbursement, loss of vehicle use, inconvenience, storage, lost time/pay, etc.

Exclusions to Warranty

1. Accessories or services not furnished by Reading, or damages/corrosions caused by these accessories or services. This includes optional parts, aftermarket products, components, installation, finish painting, lettering, wiring or modifications.
2. Specific non-rust-through and paint warranty exclusions:
 - Products which may have been used to carry corrosive materials, where such materials may result in corrosion or rust-through perforation
 - Paint warranty void if product purchased in prime paint and finished by the original owner
 - If an aftermarket liner coating is applied to the body the paint warranty will be voided due to the requirements of the liner
 - Products being warranted under the rust-through warranty must have a perforation through the metal

- Rust on a painted surface is not considered a rust-through warranty
 - Damage or corrosion caused by airborne fallout, salt from the sea air, salt or other materials used to control road conditions, chemicals, tree sap, stones, hail, earthquake, water or flood windstorm, lightning, the application of chemicals or sealants subsequent to manufacture are not covered or normal wear and tear on the product
 - Damages due to the failure to follow the recommended maintenance schedule of lubricating the hinges, locks and lock cylinders
3. Damage due to accident, misuse, abuse or alteration of the product.
 4. Fatigue cracking of the body structure caused by improper mounting, overloading, severe off-road applications, twisting loads influenced by cranes or aerial devices. The twisting exceeds the factory body twist allowance.
 5. Products purchased and used outside the United States and Canada.
 6. Products not properly maintained per maintenance instructions.
 7. Platforms only – wood floors that are found defective, in which case the replacement cost to Reading shall be limited to the following percentages:
 - 100% First year
 - 50% Second year
 - 25% Third year
 8. The SMART Racks on Reading platform bodies are covered for a period of 5 years.
 9. Translucent roofs are covered for a period of 1 year, unless misused or modified in any way.
 10. Factory bed liners are covered for a period of 1 year, unless misused or modified in any way.

Disclaimers

Reading Truck Body, LLC warrants its products only as stated in this warranty. Reading makes no other warranties, express or implied and disclaims all other warranties, including any implied warranty of merchantability or fitness for particular purpose.

Reading obligations are limited to those expressed in this warranty, and Reading shall not be liable to the purchaser or any third party for any direct or indirect, incidental or consequential damage or loss.

Some states do not allow limitations on how long an implied warranty lasts or exclusions or limitations of incidental or consequential damages so the above limitations or exclusions may not apply to you. This warranty gives you specific legal rights and you may also have other rights which may vary from state to state.

If the product is improperly installed, modified, misused, damaged or otherwise tampered with, the foregoing warranty shall lapse and become null and void.

This warranty shall be enforced and construed in accordance with the laws of Pennsylvania.

No person is authorized to modify or add to the foregoing warranty.





Preventive Maintenance – Steel Platform Bodies

- 1) **Powder Coat Maintenance** - Bodies that are equipped with powder coat paint require routine maintenance and care. This care includes periodic washing and waxing of the truckbody. The cleaners and wax, which are normally utilized on your chassis, can be used to maintain the body.

- 2) **Solvents & Cleansing Solutions** - Care must be exercised when using solvents or cleansing solutions on truck body. Read and test before applying.

- 3) **Winter Conditions** - Rinse ice and snow removal chemicals from body to prevent corrosion. NOTE: if the truck body is being used in areas where roads are chemically treated during winter months, a weekly wash of the truck body is HIGHLY RECOMMENDED.

- 4) **Lubrication** – any moving, inserting or sliding parts eg latches, posts, hinges etc apply lubrication of white lithium grease every 3- 6 months.

MAXON C2 Liftgate Specification

Model:

C2-73-1650 TP35

Application:

Flatbed and Van

Lifting Capacity:

1600

Platform Detail:

Diamond Plate: One-piece steel diamond-plate w/ 35" loading depth + 6" ramp

Drive System:

Two Hydraulic Cylinders

Hydraulic System:

All critical components are factory enclosed in the main frame of gate providing protection from elements and damage. Easy access for servicing. A pressure relief valve prevents operator from overloading the platform. A flow control valve prevents uncontrolled descent of platform. Two hydraulic cylinders: lift the platform from both sides.

Electrical System:

Moisture resistant toggle switch/deactivates 90 seconds after last operation in order to help prevent from unauthorized use, timer reset and on-off button permanently and conveniently located on control unit. A 150 Amp Continuous, 3000 Amp Interrupt, 30 VDC, watertight, push button reset circuit breaker. Mounted in-line with 4 AWG positive battery cable, protects vehicle in the event of an electrical short. Factory supplied 4 AWG ground cable molded with power cable. Provides a direct connection from the liftgate to the truck battery. License plate mount is recessed into the main frame.

Drive Train:

3/4" hard chrome plated steel parallel arm pins with self lubricating composite bushings.

Safety:

Timer deactivates passenger-side fixed control 90 seconds after last operation, in order to help prevent from unauthorized use. A pressure relief valve prevents operator from overloading the platform. Pre-punched holes in the main frame box cover to accept the truck factory backup camera and sensors.



Our Promise

A Letter from the Senior Management Team

There are times when we are asked, “In this day and age, what are the benefits of working with a family-owned company like Maxon?”

And we understand the question. We don’t expect you to choose Maxon because we’re a family-owned business. We expect you to choose Maxon based on the merits of our products and the quality of our service above all.

But, being a family-owned business is directly reflected in our ongoing drive to innovate, to create the best possible products for your needs, and to support them with a seamless network of industry professionals, so you can keep your delivery schedules, day in and day out. Since 1957, when Max Lugash developed the first Tuk-A-Way gate, this has been our singular focus. It’s all we do.

When you look a little closer, though, you’ll see there are many benefits to working with a family-owned company. First and foremost, we don’t have to wait for approval to come from afar, so you don’t have to worry that company leaders half a globe away will misunderstand your needs.

Second, you have instant access to the family management team of Maxine, Casey, and Brent, for decisions that affect your ability to do business. Simply pick up the phone and talk to us. We promise fast answers, meaningful conversations, and hard work to meet and exceed your expectations.

Finally, you can count on us to continue our drive to innovate and bring you the best possible liftgates—that same drive which has led to us becoming the largest single-brand manufacturer of liftgates in the world.

With warmest regards,

Casey Lugash

Maxine Lugash Stratton

Brent Stratton

The Maxon Senior Management Team

Light Duty

FOR PICKUPS, SERVICE BODIES, STAKEBEDS, AND CARGO VANS

Introducing the all-new Me2!

Just like the liftgates you know, but at significantly reduced cost. All of Maxon's Me2 liftgates are built with high performance and low maintenance in mind. An oversized, fully enclosed pump and motor assembly helps ensure increased life and less downtime, while maintenance-free bearings reduce the need for service.



Me2

The Me2

The Me2 lifts provide direct lift with level ride, with ramp options that increase loadable platform depth, as well as the option for steel or aluminum platforms. No matter your need, Me2 can be configured to meet it.

Visit www.maxonlift.com/products/light-duty for the latest information and configuration options.

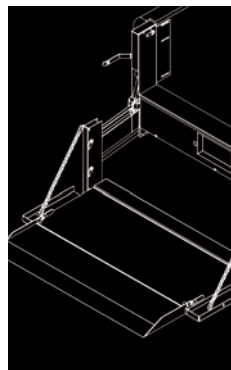

Me2

- Dual hydraulic lifting cylinders
- Maintenance-free components
- Protected / recessed main control with time-out feature
- Steel, aluminum, grip strut or bar grate platforms
- Fully-enclosed hydraulic system
- Ramp options increase loadable platform depth to 42"
- Available optional galvanized - at the same price as painted

SERIES	PLATFORM	CAPACITY	BED HEIGHT	GATE WEIGHT	RAMP OPTIONS	RECOMMENDED FOR
Me2 Pickup	55" x 27" AL, ST, GS, BG	1,300 to	28" to 42"	460 to 535 lbs	Fixed ramp	Light-Duty
	55" x 38" AL, ST	1,500 lbs				
	55" x 42" ST					
	55" x 48" AL					
Me2 Service Body	49" x 27" AL, ST	1,300 to	28" to 42"	430 to 475 lbs	Fixed ramp	Light-Duty
	49" x 38" AL, ST	1,600 lbs				
	49" x 42" ST					
	49" x 48" AL					
	50" x 27" GS, BG					
Me2 Stakebed & Van Body	87" x 33" GS, BG	1,600 lbs	30" to 50"	561 to 655 lbs	Fixed ramp	Light-Duty
	87" x 35" ST					
	87" x 37" AL					
	87" x 41" AL, ST					

■ Light-Duty
 ■ Medium-Duty
 ■ Heavy-Duty

ST = Steel, **AL** = Aluminum, **ST/AL** = Steel/Aluminum, **GS** = Grip Strut, **BG** = Bar Grate



MAXON LIFT CORP.
11921 Slauson Avenue
Santa Fe Springs, CA 90670

www.maxonlift.com

1.800.227.4116

DISTRIBUTED BY:



WARRANTY LIFTGATE AND PARTS WARRANTY

Type of Warranty: Full Parts and Labor
 Term of Warranty: Standard Liftgates - 2 years from ship date or 6,000 cycles
 Premium Liftgates - 2 years from ship date or 10,000 cycles

This warranty shall not apply unless the product is installed, operated and maintained in accordance with MAXON Lift' in MAXON Lift's Installation, Operation and Maintenance manuals. This warranty does not cover normal wear, maintenance or adjustments, damage or malfunction caused by improper handling, installation, abuse, misuse, negligence, or carelessness of operation. In addition, this

MAXON agrees to replace any components which are found to be defective during the warranty period, and will reimburse for labor based on MAXON's Liftgate Warranty Flat Rate Schedule. (Copy of the Flat Rate is available at www.maxonlift.com.)

All warranty repairs must be performed by an authorized MAXON warranty facility. For any repairs that may exceed \$500, including parts and labor, MAXON's T

All claims for warranty must be received within 30 Days of the repair date, and include the following information:

1. Liftgate Model Number and Serial Number
2. The End User must be referenced on the claim
3. Detailed Description of Problem
4. Corrective Action Taken, and Date of Repair
5. Parts used for Repair, Including MAXON Part Number(s)
6. MAXON R.M.A. # and/or Authorization # if applicable (see below)
7. Person contacted at MAXON if applicable
8. Claim must show detailed information i.e. Labor rate and hours of work performed

Warranty claims can also be placed on-line at www.maxonlift.com. On-line claims will be given priority processing.

All claims for warranty will be denied if paperwork has not been received or claim submitted via Maxon website for processing by MAXON's Warranty Department within 30 days of repair date.

All components may be subject to return for inspection, prior to the claim being processed. MAXON products may not be returned without prior written approval from MAXON's Technical Service Department. Returns must be accompanied by a copy of the original invoice or reference with original invoice number and are subject to a credit deduction to cover handling charges and any necessary reconditioning costs. Unauthorized returns will be refused and will become the responsibility of the returnee.

Any goods being returned to MAXON Lift must be pre-approved for return, and have the R.M.A. number written on the outside of the package in plain view, and returned freight prepaid. All returns are subject to a 30% handling charge.

Defective Parts requested for return must be returned within 30 days of the claim date for consideration to:

MAXON Lift Corp.
 10321 Greenleaf, Santa Fe Springs, CA 90670
 Attn: RMA#__

MAXON's warranty policy does not include the reimbursement for travel time, towing, vehicle rental, service calls, oil, batteries or loss of income due to downtime. Fabrication or use of non Maxon parts, which are available from MAXON, are also not covered.

MAXON's Flat Rate Labor Schedule takes into consideration the time required for diagnosis of a problem.

PURCHASE PART WARRANTY

Term of Warranty: 1 Year from Date of Purchase
 Type of Warranty: Part replacement only

MAXON will guarantee all returned genuine MAXON replacement parts upon receipt and inspection of parts and original invoice. All warranty replacements parts will be sent out via ground freight. If a Rush Shipment is requested all freight charges will be billed to the requesting party.





E-Z Step 3-Step



[View Larger Image](#)

Description

The E-Z Step provides an easy-to-use, stable, and safe means for drivers to enter and exit trucks and trailers. Provides easy access to flatbeds for cargo containment inspections. Easy to install: simply bolt on! The treads have a special Sure-Grip surface to provide maximum traction. Comes complete with durable, black powder coat finish, ready to mount. Includes a LIFETIME WARRANTY on materials and workmanship. E-Z Step is made in the U.S.A. and manufactured in accordance with ISO 9001 Standards.

The economical, effective solution for:

- Snowplow/Salt Spreaders
- Rear Doors
- Food Service Trailers
- Van Bodies
- Side Doors

In Use Dimensions:

- Length: 28"
- Out from truck: 14"

Stowed Dimensions:

- Length: 28-1/2"
- Distance from bottom of truck/trailer: 15"

Specifications:

- Three Rungs
- Length: 31"
- Width: 14.5"
- Weight: 24 lbs.
- 400 lb. weight capacity



**RIDER B
TERMS AND CONDITIONS**

- 1. DEFINITIONS:** The following definitions are applicable to these standard terms and conditions:
 - a. The term “Buyer” or “State” shall refer to the Government of the State of Maine or a person representing the Government of the State of Maine.
 - b. The term “Department” or “DAFS” shall refer to the State of Maine Department of Administrative and Financial Services.
 - c. The term “Bureau” or “BGS” shall refer to the State of Maine Bureau of General Services.
 - d. The term “Division” shall refer to the State of Maine Division of Purchases.
 - e. The term “Contractor”, “Vendor”, or “Provider” shall refer to the organization that is providing goods and/or services through the contract to which these standard terms and conditions have been attached and incorporated.
 - f. The term “Contract” or “Agreement” shall refer to the contract document to which these standard terms and conditions apply, taking the format of a Buyer Purchase Order (BPO) or Master Agreement (MA) or other contractual document that is mutually agreed upon between the State and the Contractor.

- 2. WARRANTY:** The Contractor warrants the following:
 - a. That all goods and services to be supplied by it under this Contract are fit and sufficient for the purpose intended, and
 - b. That all goods and services covered by this Contract will conform to the specifications, drawing samples, symbols or other description specified by the Division, and
 - c. That such articles are merchantable, good quality, and free from defects whether patent or latent in material and workmanship, and
 - d. That all workmanship, materials, and articles to be provided are of the best grade and quality, and
 - e. That it has good and clear title to all articles to be supplied by it and the same are free and clear from all liens, encumbrances and security interest.

Neither the final certificate of payment nor any provision herein, nor partial nor entire use of the articles provided shall constitute an acceptance of work not done in accordance with this agreement or relieve the Contractor liability in respect of any warranties or responsibility for faulty material or workmanship. The Contractor shall remedy any defects in the work and pay any damage to other work resulting therefrom, which shall appear within one year from the date of final acceptance of the work provided hereunder. The Division of Purchases shall give written notice of observed defects with reasonable promptness.

3. TAXES: Contractor agrees that, unless otherwise indicated in the order, the prices herein do not include federal, state, or local sales or use tax from which an exemption is available for purposes of this order. Contractor agrees to accept and use tax exemption certificates when supplied by the Division as applicable. In case it shall ever be determined that any tax included in the prices herein was not required to be paid by Contractor, Contractor agrees to notify the Division and to make prompt application for the refund thereof, to take all proper steps to procure the same and when received to pay the same to the Division.

4. PACKING AND SHIPMENT: Deliveries shall be made as specified without charge for boxing, carting, or storage, unless otherwise specified. Articles shall be suitably packed to secure lowest transportation cost and to conform to the requirements of common carriers and any applicable specifications. Order numbers and symbols must be plainly marked on all invoices, packages, bills of lading, and shipping orders. Bill of lading should accompany each invoice. Count or weight shall be final and conclusive on shipments not accompanied by packing lists.

5. DELIVERY: Delivery should be strictly in accordance with delivery schedule. If Contractor's deliveries fail to meet such schedule, the Division, without limiting its other remedies, may direct expedited routing and the difference between the expedited routing and the order routing costs shall be paid by the Contractor. Articles fabricated beyond the Division's releases are at Contractor's risk. Contractor shall not make material commitments or production arrangements in excess of the amount or in advance of the time necessary to meet delivery schedule, and, unless otherwise specified herein, no deliveries shall be made in advance of the Division's delivery schedule. Neither party shall be liable for excess costs of deliveries or defaults due to the causes beyond its control and without its fault or negligence, provided, however, that when the Contractor has reason to believe that the deliveries will not be made as scheduled, written notice setting forth the cause of the anticipated delay will be given immediately to the Division. If the Contractor's delay or default is caused by the delay or default of a subcontractor, such delay or default shall be excusable only if it arose out of causes beyond the control of both Contractor and subcontractor and without fault of negligence or either of them and the articles or services to be furnished were not obtainable from other sources in sufficient time to permit Contractor to meet the required delivery schedule.

6. FORCE MAJEURE: The State may, at its discretion, excuse the performance of an obligation by a party under this Agreement in the event that performance of that obligation by that party is prevented by an act of God, act of war, riot, fire, explosion, flood or other catastrophe, sabotage, severe shortage of fuel, power or raw materials, change in law, court order, national defense requirement, or strike or labor dispute, provided that any such event and the delay caused thereby is beyond the control of, and could not reasonably be avoided by, that party. The State may, at its discretion, extend the time period for performance of the obligation excused under this section by the period of the excused delay together with a reasonable period to reinstate compliance with the terms of this Agreement.

7. INSPECTION: All articles and work will be subject to final inspection and approval after delivery, notwithstanding prior payment, it being expressly agreed that payment will not constitute final acceptance. The Division of Purchases, at its option, may either reject any article or work not in conformity with the requirements and terms of this order, or re-work the same at Contractor's expense. The Division may reject the entire shipment where it consists of a quantity of similar articles and sample inspection discloses that ten (10%) percent of the articles inspected are defective, unless Contractor agrees to reimburse the Division for the cost of a complete inspection of the articles included in such shipment. Rejected material may be returned at Contractor's risk and expense at the full invoice price plus applicable incoming transportation charges, if any. No replacement of defective articles or work shall be made unless specified by the Division.

8. INVOICE: The original and duplicate invoices covering each and every shipment made against this order showing Contract number, Vendor number, and other essential particulars, must be forwarded promptly to the ordering agency concerned by the Vendor to whom the order is issued. Delays in receiving invoice and also errors and omissions on statements will be considered just cause for withholding settlement without losing discount privileges. All accounts are to be carried in the name of the agency or institution receiving the goods, and not in the name of the Division of Purchases.

9. ALTERATIONS: The Division reserves the right to increase or decrease all or any portion of the work and the articles required by the bidding documents or this agreement, or to eliminate all or any portion of such work or articles or to change delivery date hereon without invalidating this Agreement. All such alterations shall be in writing. If any such alterations are made, the contract amount or amounts shall be adjusted accordingly. In no event shall Contractor fail or refuse to continue the performance of the work in providing of articles under this Agreement because of the inability of the parties to agree on an adjustment or adjustments.

10. TERMINATION: The Division may terminate the whole or any part of this Agreement in any one of the following circumstances:

- a. The Contractor fails to make delivery of articles, or to perform services within the time or times specified herein, or
- b. If Contractor fails to deliver specified materials or services, or
- c. If Contractor fails to perform any of the provisions of this Agreement, or
- d. If Contractor so fails to make progress as to endanger the performance of this Agreement in accordance with its terms, or
- e. If Contractor is adjudged bankrupt, or if it makes a general assignment for the benefit of its creditors or if a receiver is appointed because of its insolvency, or
- f. Whenever for any reason the State shall determine that such termination is in the best interest of the State to do so.

In the event that the Division terminates this Agreement in whole or in part, pursuant to this paragraph with the exception of 8(f), the Division may procure (articles and services similar to those so terminated) upon such terms and in such manner as the Division deems appropriate, and Contractor shall be liable to the Division for any excess cost of such similar articles or services.

11. NON-APPROPRIATION: Notwithstanding any other provision of this Agreement, if the State does not receive sufficient funds to fund this Agreement and other obligations of the State, if funds are de-appropriated, or if the State does not receive legal authority to expend funds from the Maine State Legislature or Maine courts, then the State is not obligated to make payment under this Agreement.

12. COMPLIANCE WITH APPLICABLE LAWS: Contractor agrees that, in the performance hereof, it will comply with applicable laws, including, but not limited to statutes, rules, regulations or orders of the United States Government or of any state or political subdivision(s) thereof, and the same shall be deemed incorporated herein by reference. Awarding agency requirements and regulations pertaining to copyrights and rights in data. Access by the grantee, the subgrantee, the Federal grantor agency, the Comptroller General of the United

States, or any of their duly authorized representatives to any books, documents, papers and records of the Contractor which are directly pertinent to that specific contract for the purpose of making audit, examination, excerpts, and transcriptions. Retention of all required records for three years after grantees or subgrantees make final payments and all other pending matters are closed. Compliance with all applicable standards, orders, or requirements issued under section 306 of the Clean Air Act (42 U.S.C. 1857(h), section 508 of the Clean Water Act, (33 U.S.C. 1368), Executive Order 11738, and Environmental Protection Agency regulations (40 CFR part 15). (Contracts, subcontracts, and subgrants of amounts in excess of \$100,000). Mandatory standards and policies relating to energy efficiency which are contained in the state energy conservation plan issued in compliance with Energy Policy and Conservation Act (Pub. L. 94-163, 89 Stat. 871).

13. INTERPRETATION: This Agreement shall be governed by the laws of the State of Maine as to interpretation and performance.

14. DISPUTES: The Division will decide any and all questions which may arise as to the quality and acceptability of articles provided and installation of such articles, and as to the manner of performance and rate of progress under this Contract. The Division will decide all questions, which may arise as to the interpretation of the terms of this Agreement and the fulfillment of this Agreement on the part of the Contractor.

15. ASSIGNMENT: None of the sums due or to become due nor any of the work to be performed under this order shall be assigned nor shall Contractor subcontract for completed or substantially completed articles called for by this order without the Division's prior written consent. No subcontract or transfer of agreement shall in any case release the Contractor of its obligations and liabilities under this Agreement.

16. STATE HELD HARMLESS: The Contractor agrees to indemnify, defend, and save harmless the State, its officers, agents, and employees from any and all claims and losses accruing or resulting to any and all contractors, subcontractors, material men, laborers and other persons, firm or corporation furnishing or supplying work, services, articles, or supplies in connection with the performance of this Agreement, and from any and all claims and losses accruing or resulting to any person, firm or corporation who may be injured or damaged by the Contractor in the performance of this Agreement.

17. SOLICITATION: The Contractor warrants that it has not employed or written any company or person, other than a bona fide employee working solely for the Contractor to solicit or secure this Agreement, and it has not paid, or agreed to pay any company, or person, other than a bona fide employee working solely for the Contractor any fee, commission, percentage, brokerage fee, gifts, or any other consideration, contingent upon, or resulting from the award for making this Agreement. For breach or violation of this warranty, the Division shall have the absolute right to annul this agreement or, in its discretion, to deduct from the Agreement price or consideration, or otherwise recover the full amount of such fee, commission, percentage, brokerage fee, gifts, or contingent fee.

18. WAIVER: The failure of the Division to insist, in any one or more instances, upon the performance of any of the terms, covenants, or conditions of this order or to exercise any right hereunder, shall not be construed as a waiver or relinquishment of the future performance of any such term, covenant, or condition or the future exercise of such right, but the obligation of Contractor with respect to such future performance shall continue in full force and effect.

19. MATERIAL SAFETY: All manufacturers, importers, suppliers, or distributors of hazardous chemicals doing business in this State must provide a copy of the current Material Safety Data Sheet (MSDS) for any hazardous chemical to their direct purchasers of that chemical.

20. COMPETITION: By accepting this Contract, Contractor agrees that no collusion or other restraint of free competitive bidding, either directly or indirectly, has occurred in connection with this award by the Division of Purchases.

21. INTEGRATION: All terms of this Contract are to be interpreted in such a way as to be consistent at all times with this Standard Terms and Conditions document, and this document shall take precedence over any other terms, conditions, or provisions incorporated into the Contract.

**STATE OF MAINE
DEPARTMENT OF ADMINISTRATIVE AND FINANCIAL SERVICES
DIVISION OF PROCUREMENT SERVICES**

BID COVER PAGE

Bidder's Organization Name:		
Chief Executive - Name/Title:		
Tel:	Fax:	E-mail:
Headquarters Street Address:		
Headquarters City/State/Zip:		
<i>(provide information requested below if different from above)</i>		
Lead Point of Contact for Bid - Name/Title:		
Tel:	Fax:	E-mail:
Street Address:		
City/State/Zip:		

By signing below Bidder affirms:

- Their bid complies with all requirements of this RFQ;
- This bid and the pricing structure contained herein will remain firm for a period of 180 days from the date and time of the bid opening;
- That no personnel currently employed by the Department or any other State agency participated, either directly or indirectly, in any activities relating to the preparation of the Bidder's proposal;
- That no attempt has been made or will be made by the Bidder to induce any other person or firm to submit or not to submit a proposal; and
- The undersigned is authorized to enter into contractual obligations on behalf of the above-named organization.

Name:	Title:
Authorized Signature:	Date:

Debarment, Performance, and Non-Collusion Certification

By signing this document, I certify to the best of my knowledge and belief that the aforementioned organization, its principals, and any subcontractors named in this proposal:

- a. Are not presently debarred, suspended, proposed for debarment, and declared ineligible or voluntarily excluded from bidding or working on contracts issued by any governmental agency.*
- b. Have not within three years of submitting the proposal for this contract been convicted of or had a civil judgment rendered against them for:*
 - i. fraud or a criminal offense in connection with obtaining, attempting to obtain, or performing a federal, state or local government transaction or contract.*
 - ii. violating Federal or State antitrust statutes or committing embezzlement, theft, forgery, bribery, falsification or destruction of records, making false statements, or receiving stolen property;*
 - iii. are not presently indicted for or otherwise criminally or civilly charged by a governmental entity (Federal, State or Local) with commission of any of the offenses enumerated in paragraph (b) of this certification; and*
 - iv. have not within a three (3) year period preceding this proposal had one or more federal, state or local government transactions terminated for cause or default.*
- c. Have not entered into a prior understanding, agreement, or connection with any corporation, firm, or person submitting a response for the same materials, supplies, equipment, or services and this proposal is in all respects fair and without collusion or fraud. The above-mentioned entities understand and agree that collusive bidding is a violation of state and federal law and can result in fines, prison sentences, and civil damage awards.*

- Failure to provide this certification may result in the disqualification of the Bidder’s proposal, at the discretion of the Department.**

To the best of my knowledge all information provided in the enclosed proposal, both programmatic and financial, is complete and accurate at the time of submission.

Name:	Title:
Authorized Signature:	Date:

Appendix D

**STATE OF MAINE
DEPARTMENT OF ADMINISTRATIVE AND FINANCIAL SERVICES
DIVISION OF PROCUREMENT SERVICES**

**MUNICIPALITY POLITICAL SUBDIVISION and SCHOOL DISTRICT PARTICIPATION
CERTIFICATION**

**RFQ # 17D 191105-148
Foot Platform Body, 9 ft, 3 inch, Four Variations**

The Division of Procurement Services is committed to providing purchasing opportunities for **municipalities, political subdivisions and school districts** in Maine by allowing them access, through our vendors, to our contract pricing. A bidder's willingness to extend contract pricing to these entities will be taken into consideration in making awards.

Will you accept orders from political subdivisions and school districts in Maine at the prices quoted?

X Yes

Yes, with conditions as follows:

No

Name of Company: HEWS COMPANY, LLC

Address: 190 RUMERY STREET, SOUTH PORTLAND, ME 04106

Signature: Robert E News

Date: 11/19/2019

SUPPLIER PART NUMBER	SUPPLIER NAME	MANUFACTURER NAME	ITEM DESCRIPTION	EXTENDED DESCRIPTION	UNIT OF MEASURE	LIST PRICE	DELIVERY DAYS
H-9-W	Hews Company, LLC	Reading	Platform Stake Body, 112 x 96, Uninstalled	Includes: Stake pockets, racks, headboard, ship lap treated yellow pine floor, LED marker lights, three year limited warranty, dump hitch plate, 2 inch receiver, d-rings 7 prong round plug, back up alarm, ICC bumper, rear flaps, flap brackets, anti-sail flaps	EA	\$5,325.00	60
H-9-W-INSTALLED	Hews Company, LLC	Reading	Platform Stake Body, 112 x 96, Installed	Includes: Stake pockets, racks, headboard, ship lap treated yellow pine floor, LED marker lights, three year limited warranty, dump hitch plate, 2 inch receiver, d-rings 7 prong round plug, back up alarm, ICC bumper, rear flaps, flap brackets, anti-sail flaps	EA	\$6,478.00	60
ME2-C2	Hews Company, LLC	MAXON	Lift, 1600lb, Platform Stake Body, Uninstalled	Steel galvanized platform, dual hydraulic lifting cylinders, protected / recessed main control, fully enclosed hydraulic system	EA	\$2,175.00	60
ME2-C2-INSTALLED	Hews Company, LLC	MAXON	Lift, 1600lb, Platform Stake Body, Installed	Steel galvanized platform, dual hydraulic lifting cylinders, protected / recessed main control, fully enclosed hydraulic system	EA	\$3,025.00	60
RD-RTB-4016-09	Hews Company, LLC	Reading	Hoist, Hyd, 7.7 Ton Cap, Platform Stake Body, Uninstalled	Class 40/D, electric hydraulic, DA acting powered, in cab controls, three-year limited warranty	EA	\$2,950.00	60
RD-RTB-4016-09-INSTALLED	Hews Company, LLC	Reading	Hoist, Hyd, 7.7 Ton Cap, Platform Stake Body, Installed	Class 40/D, electric hydraulic, DA acting powered, in cab controls, three-year limited warranty	EA	\$3,715.00	60
SWINGGATE	Hews Company, LLC	Reading	Swing Gate Conversion, Platform Stake Body, Uninstalled	With bolt on hinges	EA	\$85.00	60
SWINGGATE-INSTALLED	Hews Company, LLC	Reading	Swing Gate Conversion, Platform Stake Body, Installed	With bolt on hinges	EA	\$310.00	60
STEP-FLIP	Hews Company, LLC	Reading	Flip Down Step, Platform Stake Body, Uninstalled	Pull out, flip down step (ladder), 400lb capacity, 14.5" wide, 3 grip strut rungs 12" o/c	EA	\$315.00	60
STEP-FLIP-INSTALLED	Hews Company, LLC	Reading	Flip Down Step, Platform Stake Body, Installed	Pull out, flip down step (ladder), 400lb capacity, 14.5" wide, 3 grip strut rungs 12" o/c	EA	\$400.00	60



HEWS COMPANY, LLC
190 RUMERY STREET
SOUTH PORTLAND ME 04106
PHONE: (207) 767-2136
FAX: (207) 767-5381

ATTN:DAN ROLFE
MAINE DEPT OF TRANS-AUGUSTA
STATE HOUSE STATION 26
105 CAPITAL STREET
AUGUSTA ME 04333-0026

Quote Date: 11/19/19
Order #: U75311
Sales Rep: DAVE GAIN
Customer #: 13246
Telephone #: 207-624-3132
Fax #: 207-287-8757

- 1 - 9' STAKE BODY MODEL: H-9-W HEAVY DUTY
- Length: 9' 4" Width: 96"
- Stake Pockets, 2x4" on 24" centers
- Racks: 42" Galvanneal Coated, 11ga stakes,14ga slats,Black-Quick release.
- Headboard: 42" Stand alone steel front bulkhead w/braces-welded at front.
- Window in front bulkhead, 12" reinforced cab shield.
- Floor: 4.75"x1.5" ship lap treated yellow pine.
- Cross members 3.5" x 10 ga - 16" centers with gussets.
- Longsills: 5" Structural channel, and 112" long, 34" o/c.
- LED Marker lights, reflectors, loom.
- Polyester Powder Coat, Black Finish.
- Three-year limited warranty.
- Flatbed dump hitch plate bumper (1809055), 2" receiver, D-rings, 7 prong round plug. 17,000Lb MGTW Rating
- Back up Alarm.
- ICC bumper, rear flaps, flap brackets, anti-sail, flaps.

NOT INSTALLED, FOB, AUGUSTA, ME \$5,325.00*

OPTION (1)

- 1 - MAXON MODEL ME2-C2
- Capacity: 1600 Lb
- Platform: 87 x 35 x 6 (38" total) Steel-Galvanized
- Dual hydraulic lifting cylinders
- Maintenance-free components
- Protected / recessed main control with time-out features
- Steel or aluminum platforms
- Fully-enclosed hydraulic system

NOT INSTALLED, FOB, AUGUSTA, ME \$2,175.00*



HEWS COMPANY, LLC
190 RUMERY STREET
SOUTH PORTLAND ME 04106
PHONE: (207) 767-2136
FAX: (207) 767-5381

ATTN:DAN ROLFE
MAINE DEPT OF TRANS-AUGUSTA
STATE HOUSE STATION 26
105 CAPITAL STREET
AUGUSTA ME 04333-0026

Quote Date: 11/19/19
Order #: U75311
Sales Rep: DAVE GAIN
Customer #: 13246
Telephone #: 207-624-3132
Fax #: 207-287-8757

OPTION (2)

1- Pull out, Flip Down Step, 400lb capacity
- 14.5" wide, 3 Grip Strut Rungs 12" o/c
NOT INSTALLED, FOB, AUGUSTA, ME \$315.00*

OPTION (3)

1- SWING GATE CONVERSION, GALVANIZED W/ HD BOLT ON HINGES
NOT INSTALLED, FOB, AUGUSTA, ME \$85.00*

OPTION (4)

1 - READING SUBFRAME HOIST, CLASS 40/D
- Electric Hydraulic - DA acting powered,
- Includes body prop, in cab controls.
- 7.7 Ton capacity at 45 degree.
- Three-year limited warranty
NOT INSTALLED, FOB, AUGUSTA, ME \$2,950.00*

OPTION (5)

1- INSTALLATION FOR THE FOLLOWING:
- H9W PLATFORM ADD: \$1,530.00
- LIFTGATE ADD: \$850.00
- PULL OUT STEP ADD: \$85.00
- SWING GATE CONVERSION ADD: \$255.00
- SUBFRAME HOIST ADD: \$765.00

RFQ# 17D 191105-148

SALESPERSON: BOB HEWS / DAVE GAIN DAN ROLFE (207) 441-2352

VIN: FLEET ID:
MAKE/MODEL: FORD F350 YEAR: 2019-20
TRANS: AUTOMATIC ENGINE: DIESEL/GAS
GVW: 14,000 CA: 60"

Please sign order
and return 1 copy

TERMS:
1%30NET35
Sub-Total 0.00
F.E.T. 0.00
Sales Tax 0.00

Signature Date Total 0.00

QUOTE VALID FOR 30 DAYS

Appendix E

**RFQ # 17D 191105-148
Foot Platform Body, 9 ft, 3 inch, Four Variations**

CERTIFICATIONS

1.0 NONCOLLUSION BIDDING CERTIFICATION

By submission of this Bid, each Bidder and each person signing on behalf of any Bidder certifies, and in the case of a joint bid, each party certifies as to its own organization, under penalty of perjury, that to the best of its knowledge and belief:

1. The prices in this Bid have been arrived at independently without collusion, consultation, communication or agreement, for the purpose of restricting competition as to any other matter relating to such prices with any other Bidder or with any other competitor;
2. Unless otherwise required by law, the prices which have been quoted in this Bid have not been knowingly disclosed by the Bidder and will not knowingly be disclosed by the Bidder prior to opening, directly or indirectly, to any other Bidder or to any competitor; and,
3. No attempt has been made or will be made by the Bidder to induce any other person, partnership or corporation to submit or not to submit a Bid for the purpose of restricting competition.

11/19/2019
Dated

ROBERT HEWS
Printed name of Person Bidding

Authorized Signature

PRESIDENT
Title

2.0 EQUIPMENT PERFORMANCE AND WARRANTY DATA

The information provided on this form will be used in determining operating costs of the equipment. Bidder must complete this form and submitted with bid. Bids received without this information will be considered non-responsive to the bid.

1. **EQUIPMENT**: READING 9' STAKE BODY
2. **DESCRIBE THE PROCESS FOR THE SUBMISSION OF WARRANTY CLAIMS FOR**

REIMBURSEMENT OUTLINED AND SUBMITTED WITH THE BID. (written process to follow for reimbursement of warranty claims)

The purchaser shall immediately notify the local Authorized Distributor. The Purchaser or the Distributor can submit the claim using the form on www.readingbody.com/warranty-info/make-a-claim. The claim must include the model and serial number of the body, provide a detailed description of the problem and provide photographs of the entire unit including shots of the specified defect. All repairs must be authorized by Reading Truck Body prior to any work being completed.

If after the claim is reviewed, and Reading determines the product is defective in material or workmanship as claimed, Reading shall have the option to repair the defect or replace the product or any part. Reading shall not be liable for any rental reimbursement, loss of vehicle use, inconvenience, storage, lost time/pay, etc.

SEE ATTACHED MANUFACTURER'S LITERATURE FOR MORE DETAIL ON READING'S WARRANTY POLICY, AS WELL AS MAXON WARRANTY.

3. EQUIPMENT INFORMATION:

YEAR: 2019 EQUIPMENT MAKE: READING

EQUIPMENT MODEL: H9W

4. MANUFACTURER'S RECOMMENDED PREVENTATIVE MAINTENANCE SCHEDULE MUST BE PROVIDED

Preventive Maintenance – Steel Platform Bodies

1) Powder Coat Maintenance - Bodies that are equipped with powder coat paint require routine maintenance and care. This care includes periodic washing and waxing of the truck body. The cleaners and wax, which are normally utilized on your chassis, can be used to maintain the body.

2) Solvents & Cleansing Solutions - Care must be exercised when using solvents or cleansing solutions on truck body. Read and test before applying.

3) Winter Conditions - Rinse ice and snow removal chemicals from body to prevent corrosion. NOTE: if the truck body is being used in areas where roads are chemically treated during winter months, a weekly wash of the truck body is HIGHLY RECOMMENDED.

4) Lubrication – any moving, inserting or sliding parts e.g., latches, posts, hinges etc. apply lubrication of white lithium grease every 3- 6 months.

5. BASIC EQUIPMENT WARRANTY DESCRIPTION

What is Covered Under the Reading Limited Warranty?

- Platform, Landscaper SL, Stake Rack, Dump Bodies, Redi-Dek, Tool Boxes – 3 years

Reading warrants its factory applied powder coat finish against material defects for 3 years or 36,000 miles, whichever occurs first from the date of purchase.

Reading warrants its products to be free of rust-through perforation for the life of the warranty.

Reading warrants only its own products that are manufactured in its own facility for the time period outlined.

Vendor-supplied components, such as locks, hinges, lights, hoists, etc., are solely covered by the vendor’s explicit warranty. Reading does not extend beyond the vendor supplied warranty.

This limited warranty applies only when the product is properly installed by an Authorized Reading Truck Body installer and is properly maintained and used for the purpose for which it was designed. The warranty period begins on the date of purchase from the first owner/user or one year from the date the product was shipped from the Reading Truck Body manufacturing plant, whichever comes first.

SEE ATTACHED MANUFACTURER’S LITERATURE FOR MORE DETAILED WARRANTY INFORMATION.

- 6. NAME/LOCATION OF REPAIR FACILITY(S) (BOTH AUTHORIZED WARRANTY, PARTS & SERVICE PER REQUESTED LOCATION).** It is desired that at least one facility is located within 75-mile radius each region headquarters: Scarborough, Augusta, Dixfield, Bangor and Presque Isle.

WARRANTY AND SERVICE FACILITIES

ADDRESS 1: 190 RUMERY STREET, SOUTH PORTLAND, ME 04106

ADDRESS 2:

ADDRESS 3:

ADDRESS 4:

ADDRESS 5:

CONTACT NAME: DAVE GAIN TELEPHONE: 207-767-2136

EQUIPMENT PARTS PROVIDER: HEWS COMPANY, LLC

ADDRESS: 190 RUMERY STREET, SOUTH PORTLAND, ME 04106

CONTACT NAME: DAVE GAIN TELEPHONE: 207-767-2136

Attach written explanation describing the locations of the facilities, the contact name and number at each facility, the times the facilities will be available for use, the qualifications of the staff at the facilities and how the vendor will provide warranty and service at these service facilities.

Bidder certifies that they have service facilities in Maine, staffed with trained service technicians and stocked with repair parts for the equipment which is bid.

This form must be reproduced and completed for any additional equipment warranty/facility information.

NOVEMBER 19, 2019

Dated



Signature

ROBERT HEWS
Print Name

HEWS COMPANY, LLC
Company Name

3.0 SPECIFICATION COMPLIANCE

The bidder hereby certifies that the equipment(s) being bid in response to this invitation meet or exceed these specifications and that where a deviation from the specifications exists, the bidder has obtained written approval of those exceptions prior to submitting this bid.

If a conflict exists between these specifications and Federal and/or State laws, the Federal and/or State laws shall prevail and the bidder must alert the purchaser to any such conflicts.

NOVEMBER 19, 2019

Dated

ROBERT HEWS
Printed name of Person Bidding

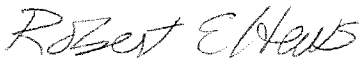

Authorized Signature

PRESIDENT
Title

Appendix F

RFQ # 17D 191105-148 Foot Platform Body, 9 ft, 3 inch, Four Variations

MaineDOT TERMS AND CONDITIONS

A. AGREEMENT

The Vendor shall deliver the equipment ordered in accordance with this Agreement and governed by these Terms and Conditions.

B. INDEPENDENT CAPACITY

In providing the equipment under the Agreement, the Vendor shall act independently and not as an agent of the State of Maine.

C. STATUS REPORTS

Prior to the start of work, the Vendor shall furnish MaineDOT with a proposed progress schedule in MaineDOT's standard format. The Vendor will outline the various phases of work that will need to be completed in order to meet the schedule set forth by MaineDOT.

During equipment assembly, the successful bidder shall submit to MaineDOT's Fleet Representative, a Monthly Status Report of accomplishments from the preceding month. The progress report shall be used to keep team members and MaineDOT's Fleet Representative informed about project status and issues. Information will include:

- a. A written statement describing the work accomplished during the period and to date.
- b. An estimate of the percentage of work completed within the specified services.
- c. Any information needed from MaineDOT to complete the project and avoid delays.
- d. The successful bidder's action plan to remedy and address any non-conforming or unacceptable work submitted to Department.
- e. Document anticipated problems and possible solutions.

These progress reports shall be submitted to MaineDOT on a **monthly basis**. Failure to submit could result in non-payment of the invoice, or be considered as a default, and shall be recorded in the Vendor's Performance Evaluation. If work is temporarily delayed, the Vendor may suspend submittal of the monthly progress reports with written approval from MaineDOT. The Vendor shall be responsible for addressing any action that may be required to keep the project on schedule.

MaineDOT shall have a period of 15 business days after receipt of the submissions to complete the review and make any necessary comments. Following the review, the Vendor will make any revisions and corrections requested by MaineDOT.

D. PAYMENT AND OTHER PROVISIONS

MaineDOT anticipates paying the selected Vendor for goods and services received, on the basis of net 30 payment terms following acceptance of the equipment, the receipt of an acceptable title and required documents, and an accurate and acceptable invoice. An invoice will be considered accurate and acceptable if it contains the State of Maine Agreement number, correct pricing information relative to the Agreement, and provides any required supporting documents, as applicable, and any other specific and agreed-upon requirements listed within the Agreement.

MaineDOT reserves the right to pay for the equipment purchased by any of several available means, which include but may not be limited to check, EFT, and/or procurement card. Vendors are advised that state statute precludes sellers from imposing a surcharge on credit or debit card purchases (text follows):

“9-A MRSA §8-303 (2): A seller in a sales transaction may not impose a surcharge on a cardholder who elects to use a credit card or debit card in lieu of payment by cash, check or similar means.”

E. WARRANTY

For a period of one (1) year following equipment delivery and acceptance (the “Warranty period”), Vendor unconditionally warrants and guarantees that the equipment shall be free from defects in parts and workmanship. If MaineDOT discovers any defects during the Warranty period, the Vendor’s obligation will be to repair or replace the equipment or refund the purchase price, at MaineDOT’s sole option subject to the following requirements as applicable:

- Replacement will be with new equipment matching the specifications within this Agreement.
- Reimbursement will be for the total purchase price of the equipment including the cost of returning the equipment.
- All Repairs including the cost of transporting the equipment will be borne by the Vendor. All repairs will be warranted free from defects in parts and workmanship for a one year period following the repair.

The Vendor hereby assigns to MaineDOT the right to enforce all manufacturer’s warranties or guarantees on the equipment.

The Vendor agrees that the warranty obligations provided by this Agreement shall be reported as an outstanding obligation in the event of bankruptcy, dissolution, or the sale, merger, or cessations of operations of the Vendor.

In the event of a breach of Vendor’s warranty obligations, MaineDOT shall notify Vendor in writing of the breach and grant Vendor 30 days to cure the breach. Should Vendor fail to cure the breach, MaineDOT may pursue whatever remedies may be available.

F. DAMAGES

Time is of the essence in the delivery of the equipment specified herein, and in event of delay(s) in the delivery of the equipment beyond the date set forth in the Agreement, or beyond authorized

extensions thereof MaineDOT may impose liquidated damages. Because it is difficult to determine the actual amount of the damage by reason of such delay it is therefore agreed that the Vendor will pay the sum of one hundred dollars (\$100.00) per unit for each calendar day(s) delay in delivery as liquidated damages and not as a penalty.

These damages shall be deducted from any monies due, or which may thereafter become due to the Vendor or may be recovered by through any lawful means.

G. SET-OFF RIGHTS

MaineDOT shall have all of its common law, equitable and statutory rights of set-off.

H. FORCE MAJEURE

Either party may be excused from performance under this Agreement to the extent the failure to perform is caused by acts of God or of the public enemy, fire, floods, epidemics, quarantine, restrictions, strikes, labor disputes, and freight embargos, or other causes beyond the party's reasonable control. In the event of such event of force majeure, the affected party shall provide the other party written notice of the cause of delay within fifteen (15) days from the beginning of any such delay. The time of performance shall be excused to extent of the duration of any such event of force majeure, or such period of time as may be mutually agreed upon by the parties.

I. INDEMNIFICATION

The Vendor shall indemnify and hold harmless MaineDOT and its officers, agents, and employees from and against any and all claims, liabilities, and costs, including reasonable attorney fees, for any or all injuries to persons or property or claims for money damages, including claims for violation of intellectual property rights, arising from the negligent acts or omissions of the Vendor, its employees or agents, officers or Subcontractors in the performance of work under this Agreement; provided, however, the Vendor shall not be liable for claims arising out of the negligent acts or omissions of MaineDOT, or for actions taken in reasonable reliance on written instructions of MaineDOT.

This indemnification provision shall survive any termination or expiration of the Agreement.

J. DEFAULT, TERMINATION

- i. MaineDOT reserves the right to terminate this Agreement or any part hereof, for its sole convenience. Thirty (30) days advance written notice shall be provided in the case of a termination for convenience. In the event of such termination, Vendor shall immediately stop all work hereunder and shall immediately cause any and all of its suppliers and subcontractors to cease work. Vendor shall be paid for all work on a percentage completed basis, as mutually agreed upon by the parties, up to the date of termination under this Paragraph 14.A.
- ii. MaineDOT shall have the right to terminate this Agreement in the event of a material breach or default by Vendor of its obligations hereunder that is not cured within thirty (30) days

from the date of receipt by Vendor of written notice of such breach from MaineDOT. If the breach or default, by its nature, cannot be cured within such thirty (30) day period, then Vendor shall have such additional time (not to exceed thirty (30) additional days) as may be necessary to cure the breach or default, provided Vendor has exercised reasonable commercial efforts and taken appropriate action to begin cure of the breach or default within the initial thirty (30) day cure period.

- iii. MaineDOT shall have the right to terminate this Agreement immediately upon written notice to Vendor in the event (i) Vendor, or any director, officer or employee of Vendor assigned to this Project is convicted of a criminal offense directly related to information technology services; or (ii) proceedings in bankruptcy are commenced against Vendor or if a receiver is appointed and such case or proceeding shall continue undismissed, or unstayed and in effect, for a period of one hundred twenty (120) days. Notwithstanding the foregoing, if a conviction of an employee assigned to this Project, officer or director, relates to individual and/or personal actions of such employee, officer or director and not the policy or directive of Vendor and, upon such conviction, Vendor shall terminate or otherwise remove such employee, officer or director and take such other steps to reasonably ensure the propriety of Vendor' delivery of information technology services, then MaineDOT shall not have a right to terminate this Agreement pursuant to the foregoing clause (i) of this Section 14 (C).
- iv. Vendor shall have the right to terminate this Agreement in the event of a material breach or default by MaineDOT of its obligations hereunder that is not cured within thirty (30) days from the date of receipt by MaineDOT of written notice of such breach from Vendor. If the breach or default, by its nature, cannot be cured within such thirty (30) day period, then MaineDOT shall have such additional time (not to exceed thirty (30) additional days) as may be necessary to cure the breach or default, provided MaineDOT has exercised reasonable commercial efforts and taken appropriate actions to begin cure of the breach or default within the initial thirty (30) day cure period.
- v. Vendor shall cause the foregoing provisions to be inserted in any subcontract for any work covered by this Agreement so that such provisions shall be binding upon each subcontractor, provided that the foregoing provisions shall not apply to contracts or subcontracts for standard commercial supplies or raw materials.

K. DELIVERY AND ACCEPTANCE

Time is of the essence in the delivery of the equipment. The Vendor shall execute the work continuously and diligently. Delivery of the units shall occur in accordance with the terms and conditions outlined in the resulting Agreement.

- i. Production of the units shall be conducted as a continuous production with no breaks or inserts of other orders or types of equipment.

- ii. Delivery shall be restricted to Monday through Friday, between the hours of 8 AM and 4 PM.
- iii. The Vendor will contact MaineDOT Fleet Services 24 hrs. prior to delivery with an estimated time of arrival.
- iv. Units furnished under this Agreement shall be delivered in first class condition, complete and ready for operation, and the Vendor shall assume all costs, responsibilities, and risk of loss related to damage that may have occurred in the delivery of the units.
- v. When units are delivered, certificates or releases signed by representatives of MaineDOT Fleet Services are understood to be a simple acknowledgment of receipt of the units only, and will NOT constitute an acceptance of the condition of the units or their conformance with the terms and conditions of the Agreement specifications.
- vi. Upon delivery, MaineDOT may conduct such tests as may be required to determine to its own satisfaction that the units appear to be in conformance with the terms, conditions, and requirements of the Agreement specifications.

Acceptance shall occur following final inspection by authorized employees of MaineDOT Fleet Service, receipt of the titles and all requested documentation. The Vendor will be notified, in writing, of acceptance/non-acceptance within fifteen calendar (15) days of delivery to the location specified in this Agreement.

L. RIGHT TO SUSPEND WORK

MaineDOT has the right to suspend any or all work at any time for any reason as it deems necessary. Consultant may receive payment for the portion of services completed through the date of suspension.

M. COPYRIGHT AND LICENSES - PATENTS AND COPYRIGHTS

Data and publication rights to any documents, produced under the terms of Agreement are the property of MaineDOT. The Vendor shall not copyright the material produced under the terms of the Agreement without written approval of MaineDOT, except to the extent necessary to protect its rights pursuant to the following paragraph.

The Parties to this Agreement mutually agree that, if patentable discoveries, intellectual property and software, or inventions should result from work described therein, all rights accruing from such discoveries or inventions shall be the sole property of MaineDOT.

N. CLAIMS AND DISPUTES

General

To preserve any claim arising out of the Agreement, the Parties shall comply with and exhaust all provisions of this Section. Unless otherwise agreed to in writing, the Vendor shall continue to

perform its services during any dispute resolution process. If the Vendor continues to perform, MaineDOT shall continue to make payments in accordance with the Agreement of amounts not in dispute.

Negotiation with MaineDOT's Fleet Representative

The Vendor shall promptly notify MaineDOT's Fleet Representative, or their designee, in writing, of disputes that could significantly affect scope, schedule or compensation. After such notice, the Vendor and MaineDOT's Fleet Representative shall promptly negotiate in good faith to resolve the dispute. MaineDOT's Fleet Representative will promptly issue a decision.

Review by Director

If the Vendor desires a review of MaineDOT's Fleet Representative's decision, then the Vendor shall promptly request in writing that MaineDOT's Director of the applicable Bureau or Office review the Fleet Representative's decision. The Director or its designee(s) shall promptly notify the Vendor in writing of the result of the review.

Dispute Resolution

If the dispute remains unresolved after negotiation and review as set forth above, the Parties may proceed to mediation by selecting a mediator acceptable to both.

If the Parties are unable to resolve the dispute through mediation, either party may seek judicial review through a civil action commenced in the Superior Court of Maine, Kennebec County.

O. CONTROLLING LAWS

The Agreement referred to in these Terms and Conditions is governed by the applicable laws of the Federal Government and the State of Maine.

Laws to Be Observed

The Vendor shall comply with all applicable Federal, State and local laws, rules, regulations, orders, and ordinances affecting the work including, without limitation all environmental, wage, labor, equal opportunity, safety, patent, copyright, or trademark laws. The Vendor shall indemnify MaineDOT and hold MaineDOT harmless against any and all claims or liabilities arising from or based upon the violation or alleged violation of any such Law caused directly or indirectly by or through the Vendor.

P. ENTIRE AGREEMENT/BINDING EFFECT/MODIFICATION/ASSIGNMENT

This Agreement sets forth the entire agreement of the parties with regard to the subject herein. This Agreement may not be modified except by a written amendment executed by both parties.

Neither MaineDOT nor the Vendor may assign, sublet, or transfer any rights under or interest (including, but without limitation, monies that are due or may become due) in the Agreement without the written consent of the other, except to the extent that any assignment, subletting, or transfer is mandated or restricted by law. Unless specifically stated to the contrary in any written Consent To Assignment, no assignment shall release or discharge the assignor from any duty or responsibility under the Agreement.

Q. SEVERABILITY

The invalidity or unenforceability of any particular provision or part thereof of this Agreement shall not affect the remainder of said provision or any other provisions, and this Agreement shall be construed in all respects as if such invalid or unenforceable provision or part thereof had been omitted.

R. NON-WAIVER

If MaineDOT fails or refuses to enforce any provision in the Agreement that shall not constitute a waiver of that provision, nor shall it affect the enforceability of that provision or of the remainder of the Agreement.

Name of Company: HEWS COMPANY, LLC

Address: 190 RUMERY STREET, SOUTH PORTLAND, ME 04106

Signature: Robert E. Hews

Date: NOVEMBER 19, 2019