



FILE NAME: H:\Projects\140009-Num_Nine_Wind_Form_ESA\Eng\CAD\CUT\140009_inL_index_pln.dwg
 DATE/TIME: 7/8/2015 5:05:38 PM
 USER: Steven Neilott



 FISHER ASSOCIATES WWW.FISHERASSOCIATES.COM 135 CALDWELL ROAD, BOSTON, MA 02128 PHONE: 617.334.1310		 NUMBER NINE WIND FARM		PROJECT: NUMBER NINE WIND FARM AROOSTOOK COUNTY, MAINE PRELIMINARY PLANS NOT FOR CONSTRUCTION		DRAWING NO. INT-0 SHEET 298 OF 338	
FA PROJECT NO. 140009 PROJECT MANAGER S. MELLOTT	DRAWN BY DP/BA SCALE AS SHOWN	ISSUE DATE JULY 2015	TITLE OF DRAWING INTERSECTION INDEX PLAN		DRAWING NO. INT-0 SHEET 298 OF 338		
FISHER ASSOCIATES, P.E./S. L.A., P.C. New York State Education Law Section 1405.4 requires that the professional seal of the professional engineer or land surveyor be placed on drawings prepared by or under the supervision of the professional engineer or land surveyor, to alter in any way, in whole or in part, the work of the professional engineer or land surveyor. The notation, entered by a professional engineer or land surveyor, shall indicate the date of the alteration, and a specific description of the alteration.		REV 7 6 5 4 3 2 1		DESCRIPTION DATE BY			



NOTE:
 EXISTING CONTOURS SHOWN ARE FROM
 LIDAR DATA PUBLISHED BY THE MAINE
 OFFICE OF GEOGRAPHIC INFORMATION
 SYSTEMS ON 04/08/2013.

PLAN VIEW
 BOOTFOOT ROAD & U.S. ROUTE 1
 SCALE: 1"=50' (22X34)



REV	DESCRIPTION	DATE	BY
1			
2			
3			
4			
5			
6			
7			

FA PROJECT NO.	14009
PROJECT MANAGER	S. MELLITT
DRAWN BY	DP/BA
SCALE	AS SHOWN
ISSUE DATE	JULY 2015

Copyright © 2014
 FISHER ASSOCIATES, P.E., L.S., L.A., P.C.
 This drawing is a portion of a larger drawing and is not to be used in isolation. It is the responsibility of the user to ensure that all necessary information is obtained from the complete set of drawings. No liability is assumed for errors or omissions. The user agrees to hold the author harmless for any and all claims, damages, or expenses, including attorneys' fees, arising from the use of this drawing.

PROJECT	NUMBER NINE WIND FARM
ARROSTOCK COUNTY, MAINE	PRELIMINARY PLANS NOT FOR CONSTRUCTION
TITLE OF DRAWING	INTERSECTION IMPROVEMENTS

PROJECT NO. 14009
 PROJECT MANAGER S. MELLITT
 DRAWN BY DP/BA
 SCALE AS SHOWN
 ISSUE DATE JULY 2015

NUMBER NINE WIND FARM
 WW.FISHERASSOCIATES
 150 Colburn Road, Rochester, NY 14623
 Phone: 585-234-1310

PROJECT
 NUMBER NINE WIND FARM
 AROOSTOOK COUNTY, MAINE
 PRELIMINARY PLANS NOT FOR CONSTRUCTION
 INTERSECTION IMPROVEMENTS



135 Calhoun Road, Rochester, NY 14623
 Phone: 585-534-1310
 WWW.FISHERASSOCIATES.COM

FA PROJECT NO. 14009
 PROJECT MANAGER S. MELLOTT
 DRAWN BY DP/BA
 SCALE AS SHOWN
 ISSUE DATE JULY 2015

Copyright © 2014
 FISHER ASSOCIATES, P.E., L.S., L.A., P.C.
 This drawing was prepared by a registered professional engineer or land surveyor in the State of New York. It is the property of Fisher Associates, P.E., L.S., L.A., P.C. and is loaned to the client for the specific purpose for which it was prepared. It is not to be used for any other purpose, in whole or in part, without the written consent of Fisher Associates, P.E., L.S., L.A., P.C.

REV	DESCRIPTION	DATE	BY
1			
2			
3			
4			
5			
6			
7			

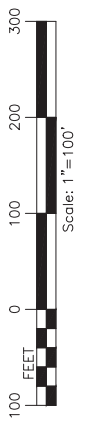

PLAN VIEW 4B
 DD ACCESS ROUTE IMPROVEMENT
 SCALE: 1"=100' (22X34)

PLAN VIEW 4A
 DD ACCESS ROUTE IMPROVEMENT
 SCALE: 1"=100' (22X34)

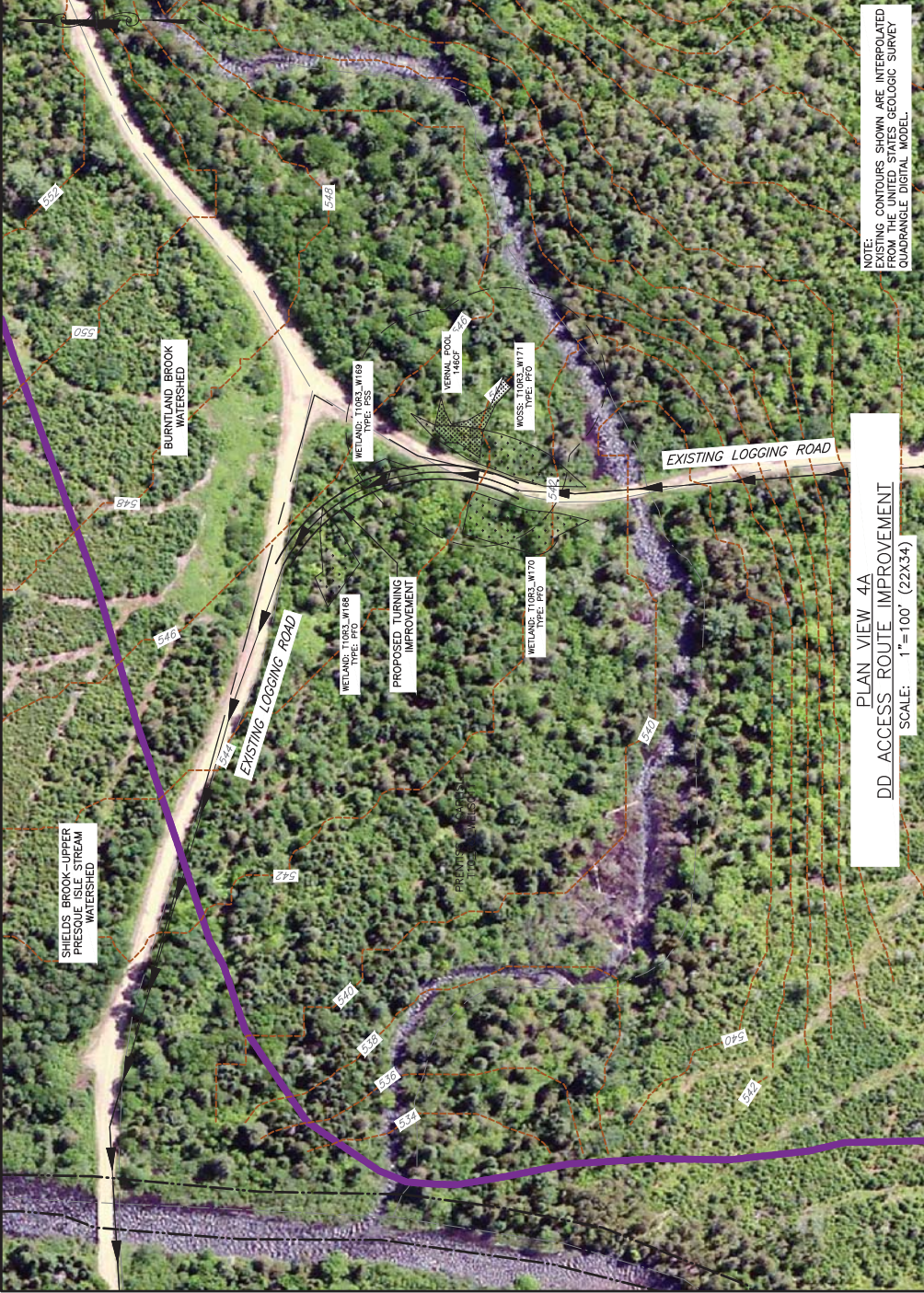

DRAWING NO.

PROJECT
NUMBER NINE WIND FARM
AROOSTOOK COUNTY, MAINE
PRELIMINARY PLANS NOT FOR CONSTRUCTION

TITLE OF DRAWING
INTERSECTION IMPROVEMENTS



135 Colburn Road, Rochester, NY 14623
Phone: 585-534-1310

FA PROJECT NO. 14009
PROJECT MANAGER S. MELLOTT
DRAWN BY DP/BA
SCALE AS SHOWN
ISSUE DATE JULY 2015

REV	DESCRIPTION	DATE	BY
1			
2			
3			
4			
5			
6			
7			

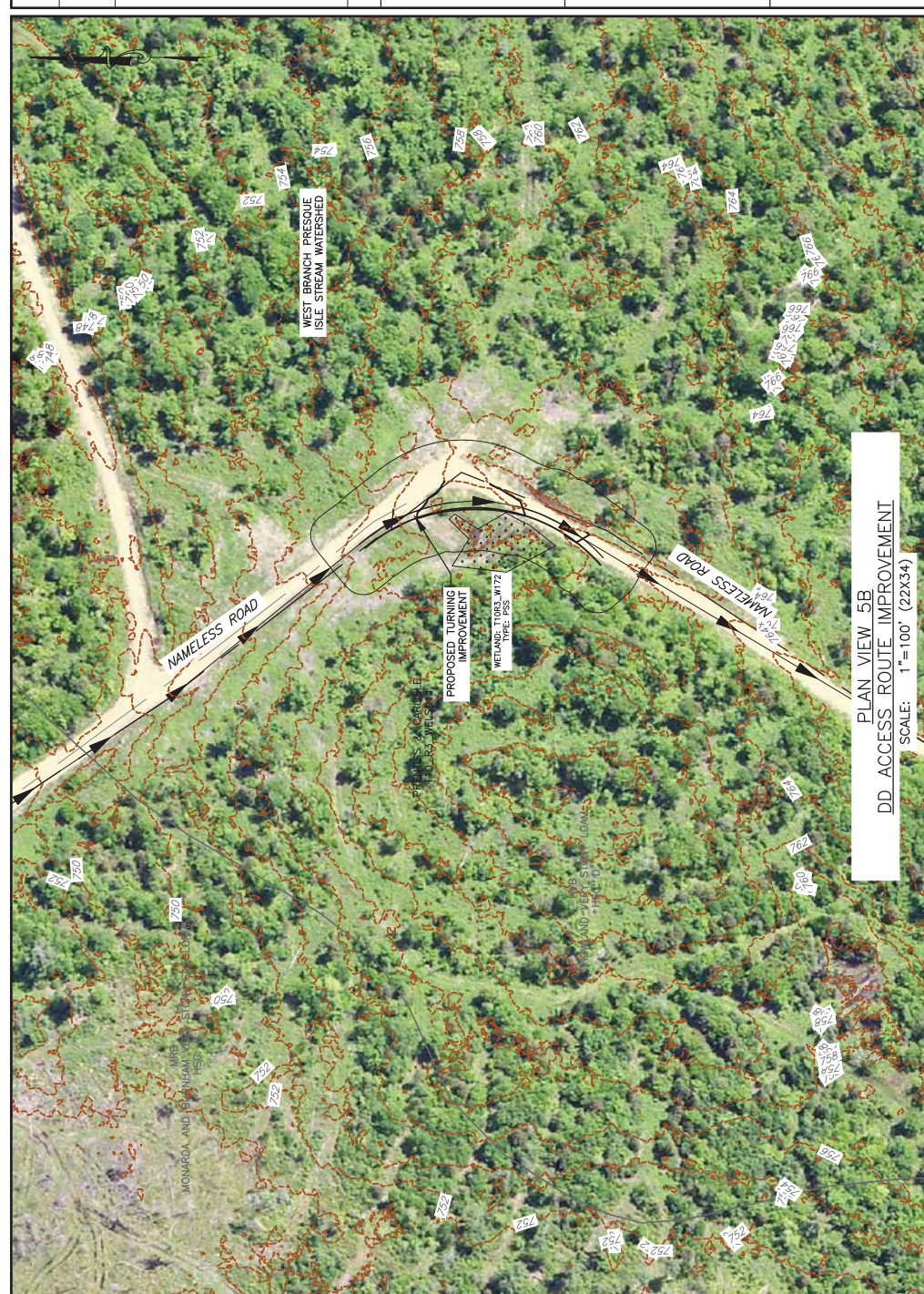

INT-6

DRAWING NO.

PROJECT
 NUMBER NINE WIND FARM
 AROOSTOOK COUNTY, MAINE
 PRELIMINARY PLANS NOT FOR CONSTRUCTION

TITLE OF DRAWING
 INTERSECTION IMPROVEMENTS



FA PROJECT NO.
 14009

PROJECT MANAGER
 S. MELLOTT

DRAWN BY
 DP/BA

SCALE
 AS SHOWN

ISSUE DATE
 JULY 2015

REV	DESCRIPTION	DATE	BY
1			
2			
3			
4			
5			
6			
7			

Copyright © 2014
 FISHER ASSOCIATES, P.E., L.A., P.C.
 2209 State Road is a violation of
 the law for any person, unless he/she
 is acting under the direction of a
 licensed professional engineer or land
 surveyor, either on their own or in
 conjunction with the firm in any way,
 to reproduce or transmit the content of
 this drawing or to use the drawing for
 any purpose other than that intended
 by the drawing engineer or land surveyor
 and the firm. Any such use is a violation
 of the profession's code of ethics and
 may constitute a criminal offense.



DRAWING NO.

PROJECT
 NUMBER NINE WIND FARM
 AROOSTOOK COUNTY, MAINE
 PRELIMINARY PLANS NOT FOR CONSTRUCTION

TITLE OF DRAWING
 INTERSECTION IMPROVEMENTS



135 Colburn Road, Rochester, NY 14623
 Phone: 585-334-1310

FA PROJECT NO. 140009
 PROJECT MANAGER S. MELLOTT
 DRAWN BY DP/BA
 SCALE AS SHOWN
 ISSUE DATE JULY 2015

Copyright © 2014
 FISHER ASSOCIATES, P.E., L.S., L.A., P.C.
 This use for any person, unless in a position of authority, is prohibited. It is a violation of the New York State Education Law Section 2209 to make use of a portion of the drawing without the written consent of the designer. The designer's name and the date of the drawing are shown on this drawing. The drawing is the property of the designer and shall not be reproduced, stored in a retrieval system, or transmitted in any form or by any means, electronic, mechanical, photocopying, recording, or by any information storage and retrieval system, without the prior written permission of the designer.

REV	DESCRIPTION	DATE	BY
1			
2			
3			
4			
5			
6			
7			

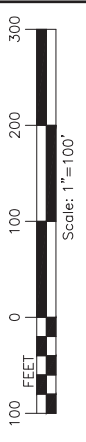
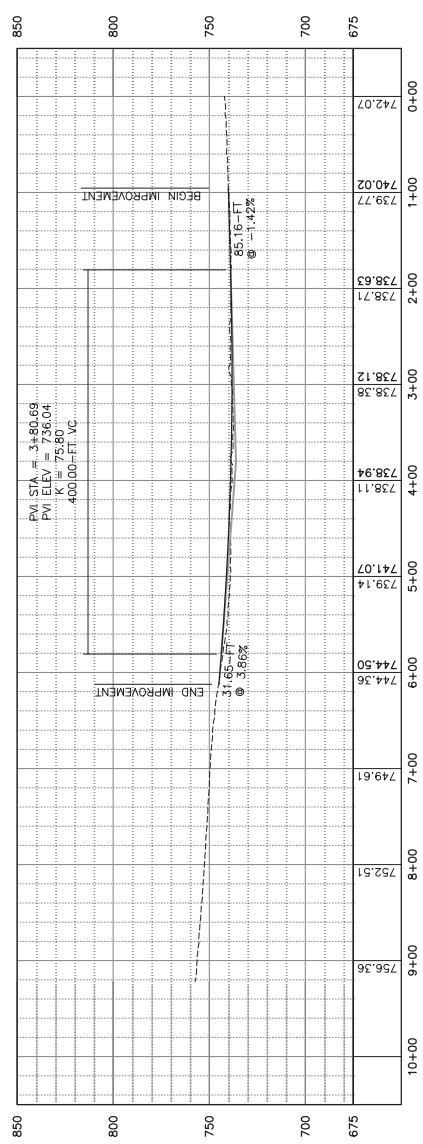
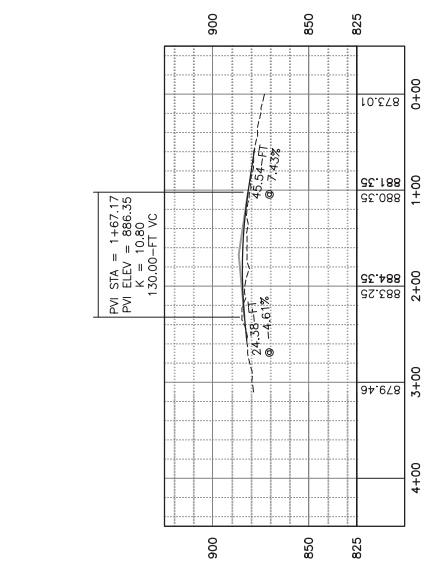
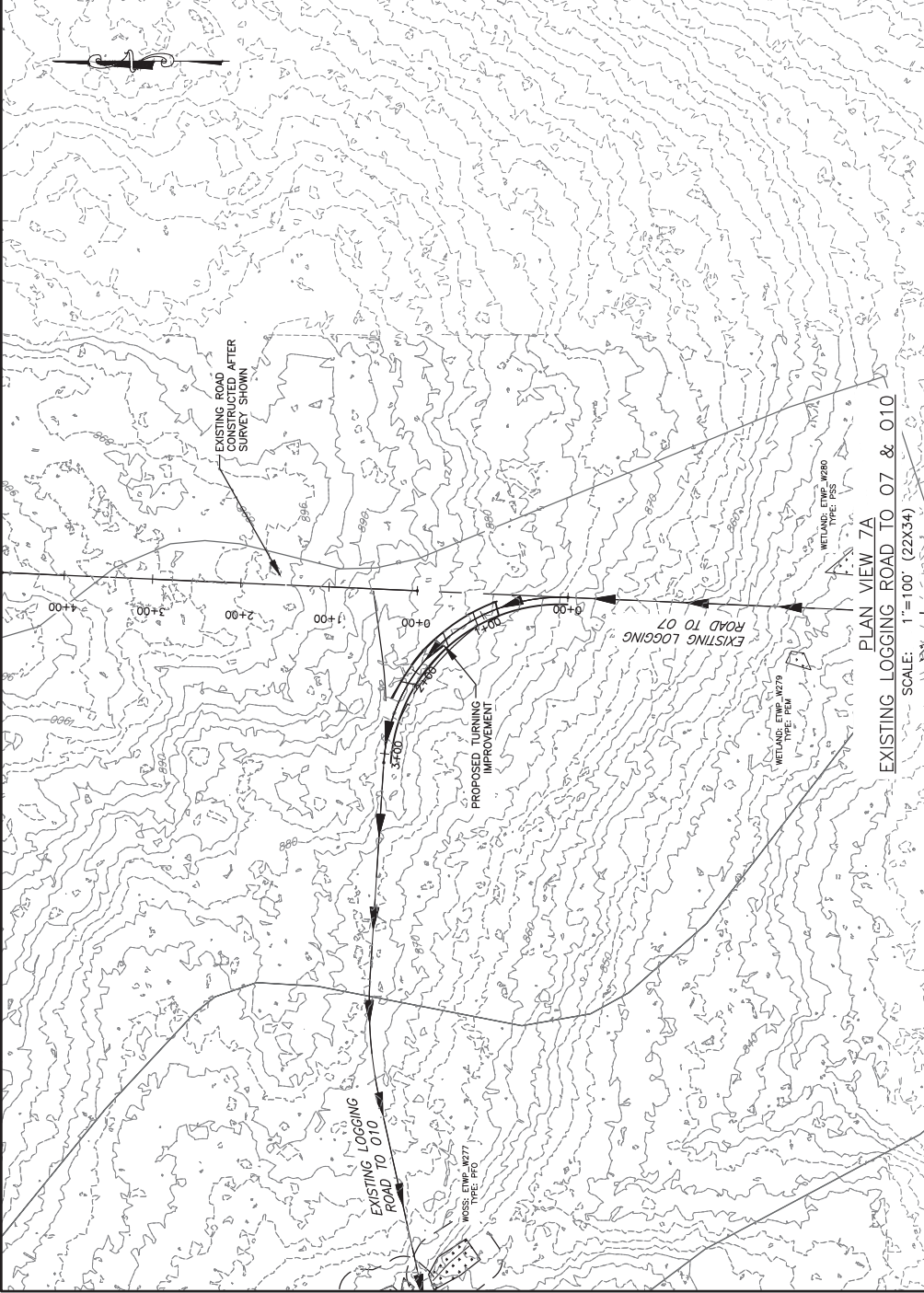
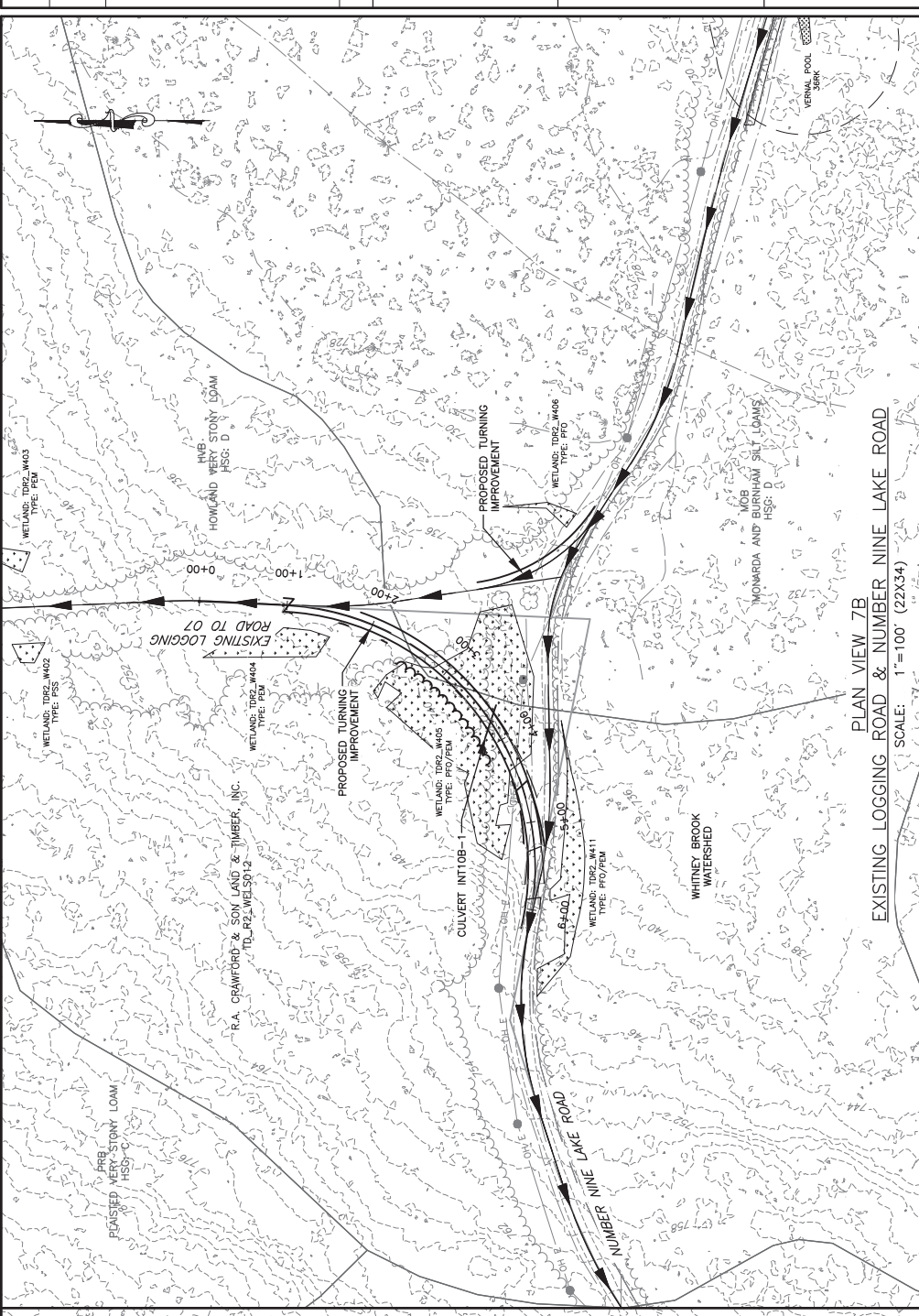

DRAWING NO.

PROJECT
 NUMBER NINE WIND FARM
 AROOSTOOK COUNTY, MAINE
 PRELIMINARY PLANS NOT FOR CONSTRUCTION

TITLE OF DRAWING
 INTERSECTION IMPROVEMENTS



135 Colburn Road, Rochester, NY 14623
 Phone: 585-534-1310

FA PROJECT NO. 14009
 PROJECT MANAGER S. MELLOTT
 DRAWN BY DP/BA
 SCALE AS SHOWN
 ISSUE DATE JULY 2015

Copyright © 2014
 FISHER ASSOCIATES, P.E., L.S., L.A., P.C.
 This drawing was prepared by a registered professional engineer and land surveyor, to offer an item in any way. It is intended for use only in connection with the project and the site of such alteration, and a specific description of the alteration.

REV	DESCRIPTION	DATE	BY
1			
2			
3			
4			
5			
6			
7			

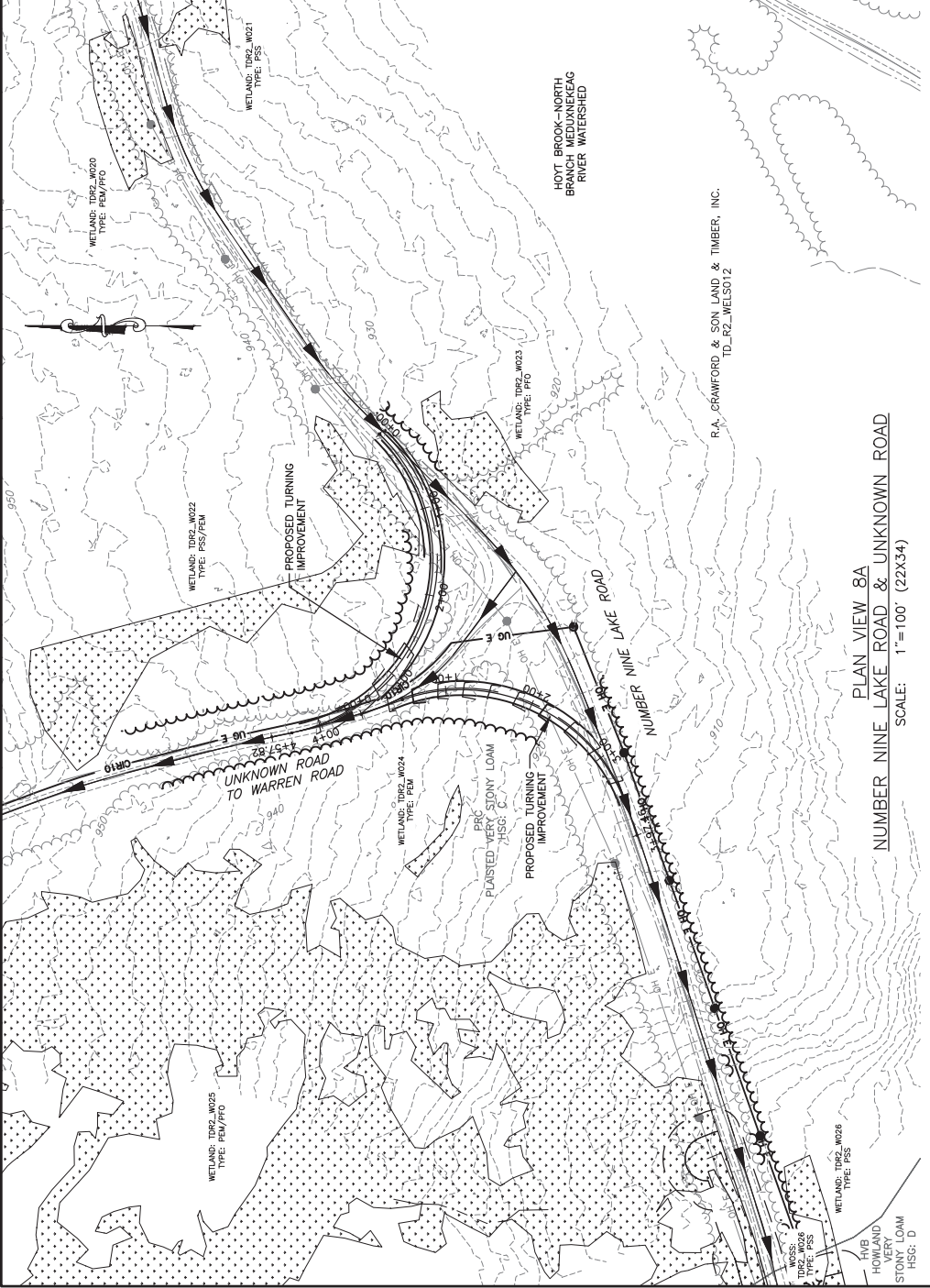
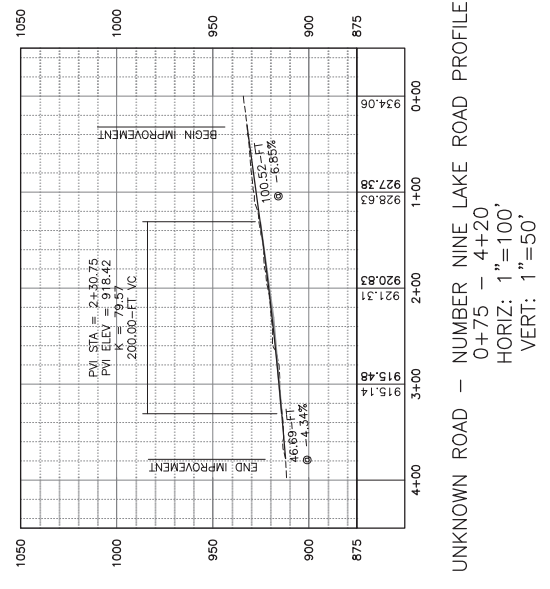
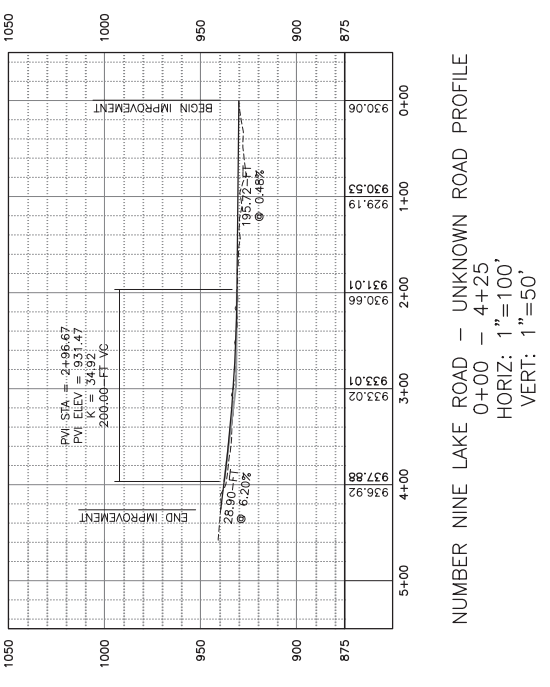

REV	DESCRIPTION	DATE	BY
1			
2			
3			
4			
5			
6			
7			

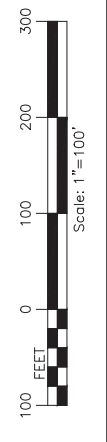
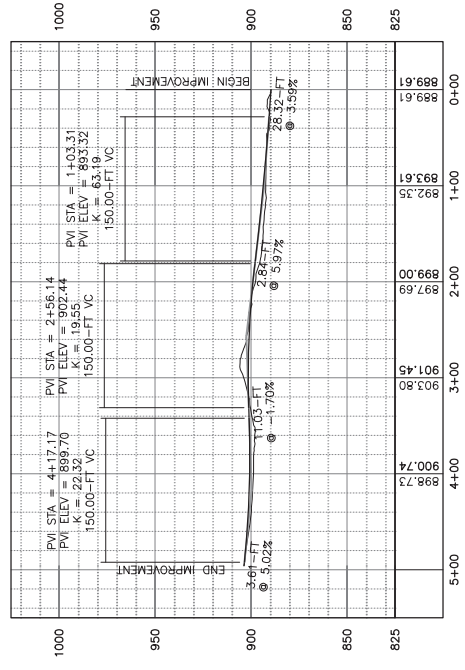
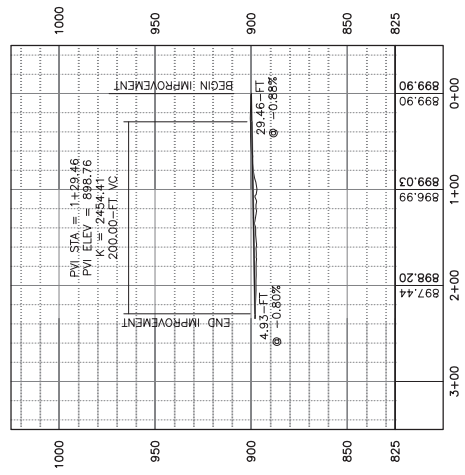
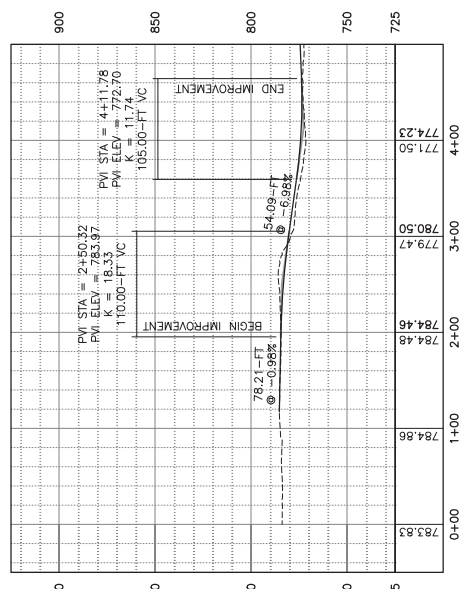
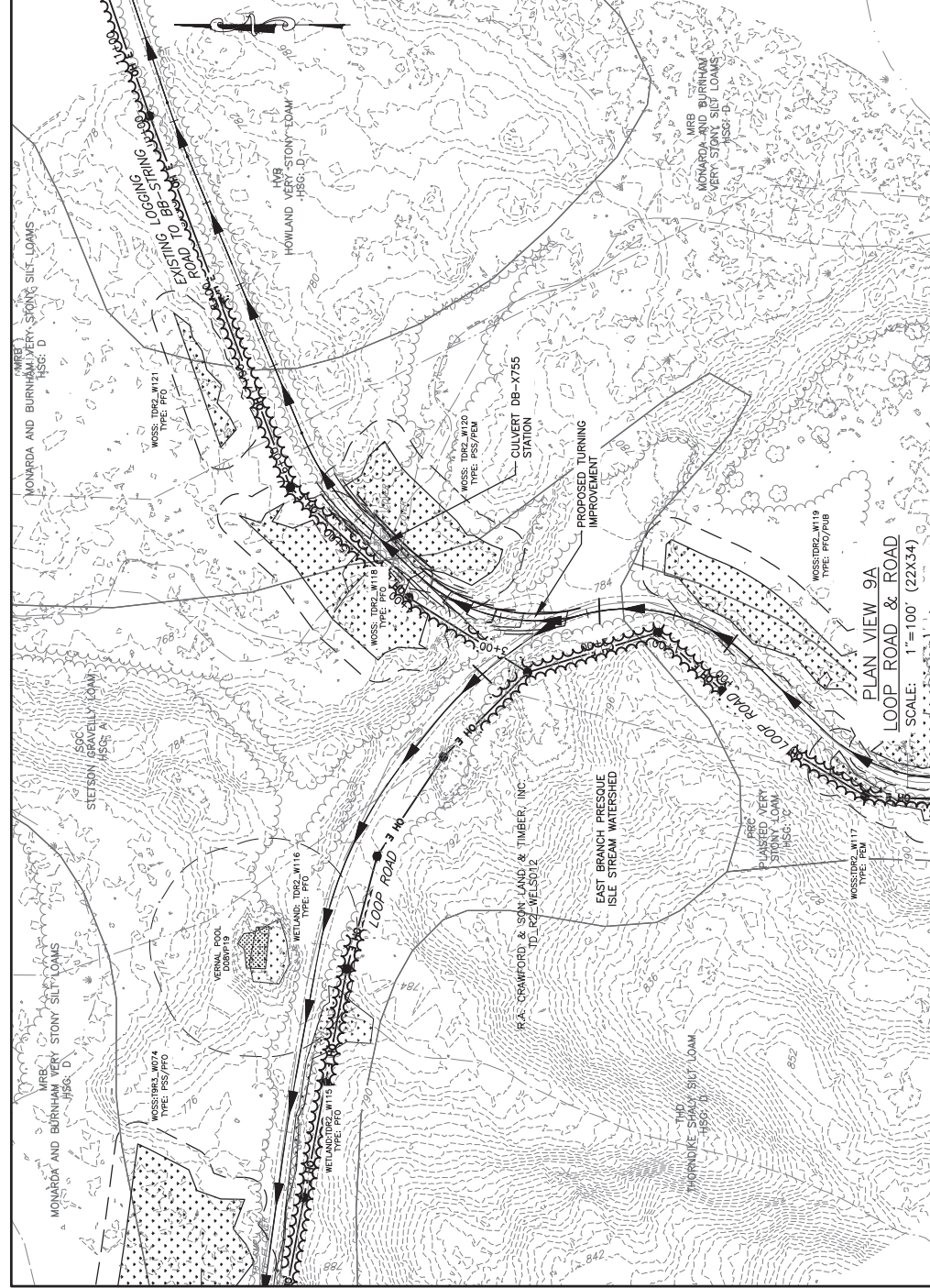
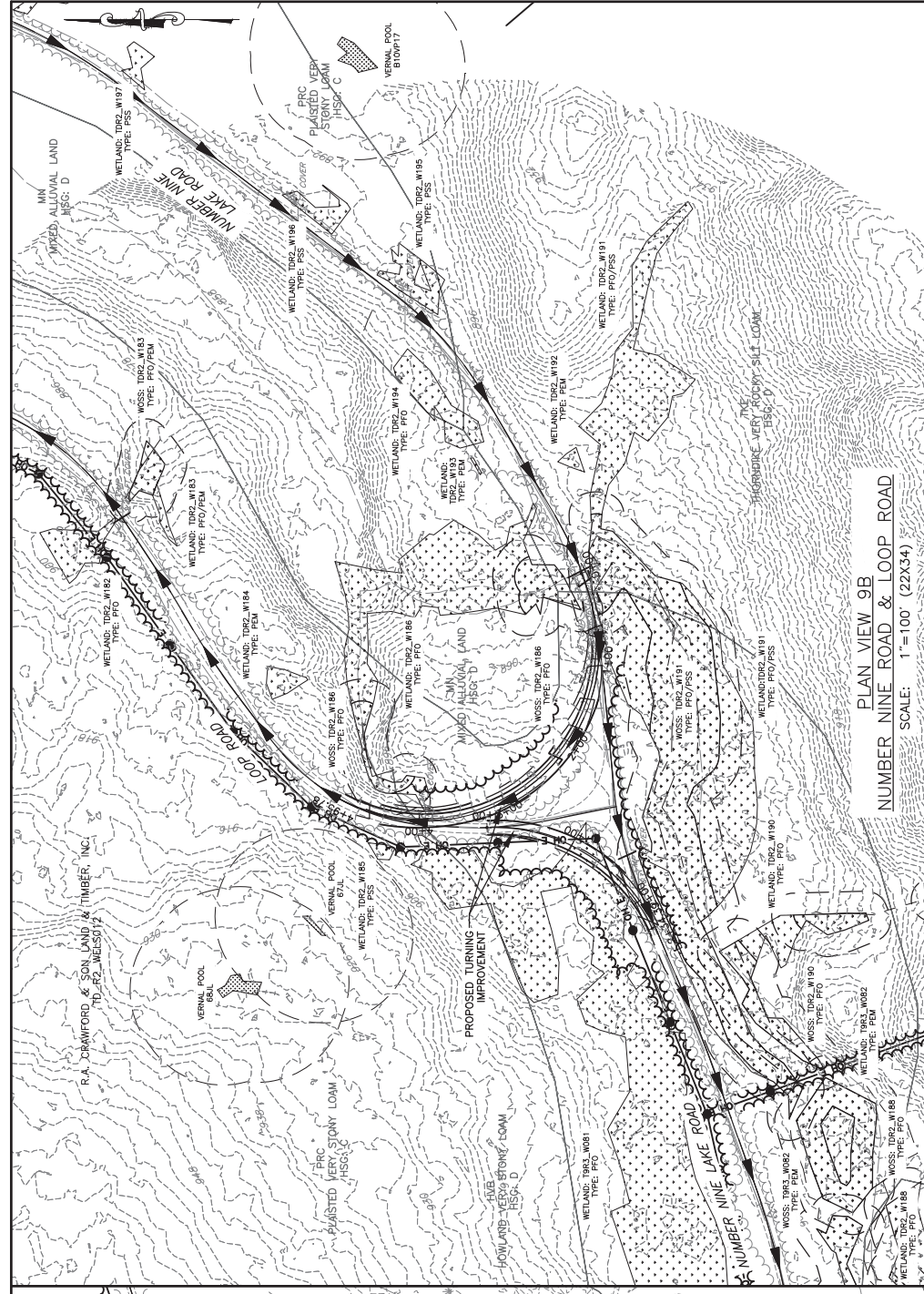

COPYRIGHT © 2014
 FISHER ASSOCIATES, P.E., L.A., P.C.
 This drawing shall be used in a professional capacity only by the engineer or land surveyor, or other person, unless written consent is obtained from the engineer or land surveyor, or other person, in any way.
 The drawing is the property of Fisher Associates, P.E., L.A., P.C. and shall not be reproduced, stored in a retrieval system, or transmitted in any form or by any means, electronic, mechanical, photocopying, recording, or by any information storage and retrieval system, without the prior written permission of Fisher Associates, P.E., L.A., P.C.

REV	DESCRIPTION	DATE	BY
1			
2			
3			
4			
5			
6			
7			

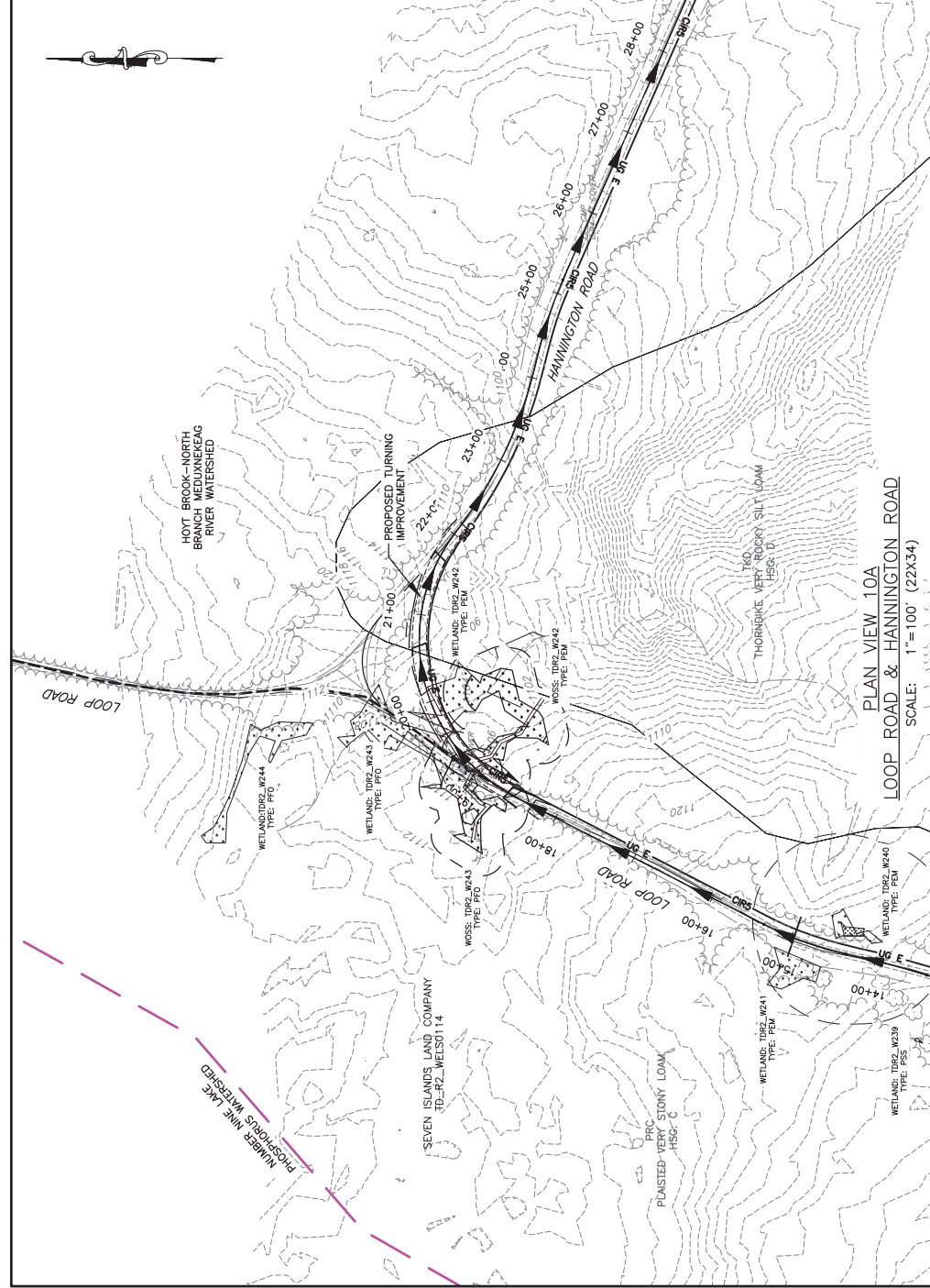

PLAN VIEW 10A
 LOOP ROAD & HANNINGTON ROAD
 SCALE: 1"=100' (22X34)

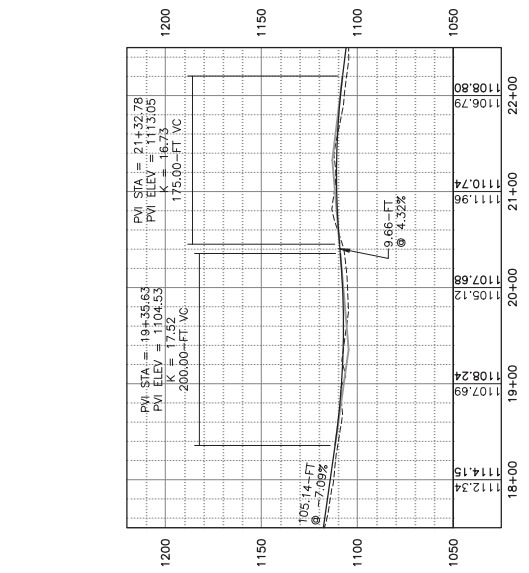

LOOP ROAD - HANNINGTON ROAD
 18+00 - 22+00
 HORIZ: 1"=100'
 VERT: 1"=50'

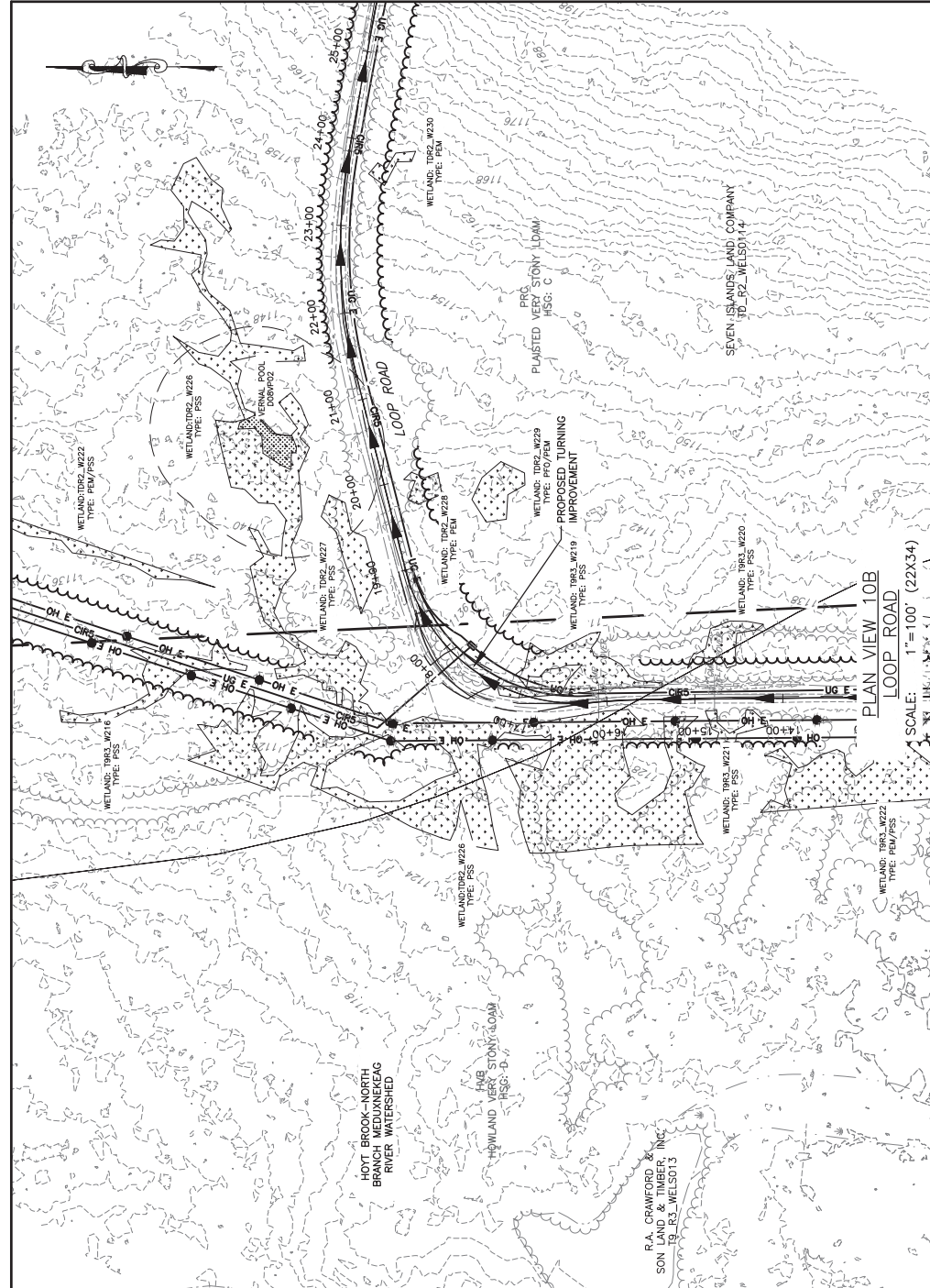

PLAN VIEW 10B
 LOOP ROAD
 SCALE: 1"=100' (22X34)

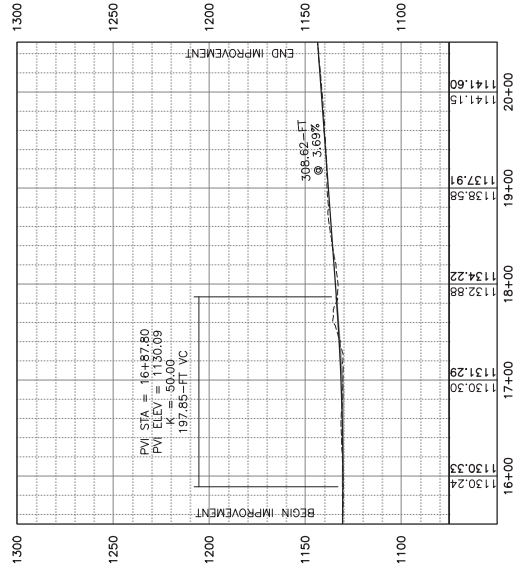

AR-1 ACCESS ROAD PROFILE
 15+50 - 20+50
 HORIZ: 1"=100'
 VERT: 1"=50'



DRAWING NO.
INT-11
SHEET 309 OF 338

PROJECT
NUMBER NINE WIND FARM
ARROSTOOK COUNTY, MAINE
PRELIMINARY PLANS NOT FOR CONSTRUCTION
TITLE OF DRAWING
INTERSECTION IMPROVEMENTS

NUMBER NINE WIND FARM



FISHER ASSOCIATES
135 Colburn Road, Rochester, NY 14623
Phone: 585-324-1310



FA PROJECT NO.
14009
PROJECT MANAGER
S. MELLOTT
DRAWN BY
DP/BA
SCALE
AS SHOWN
ISSUE DATE
JULY 2015

COPYRIGHT © 2014
FISHER ASSOCIATES, P.E., L.S., L.A., P.C.
This drawing was prepared by a registered professional engineer in the State of New York. It is a violation of the Professional Engineering Law Section 2209 to use this drawing for any purpose other than that intended by the engineer or land surveyor. It is the duty of the engineer or land surveyor to check the accuracy of the information and to take appropriate action if it is found to be incorrect.

REV	DESCRIPTION	DATE	BY
1			
2			
3			
4			
5			
6			
7			

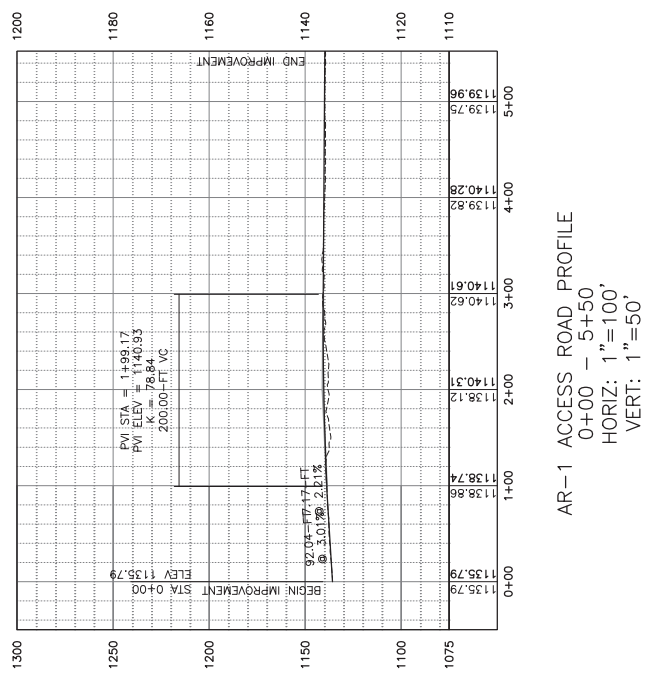
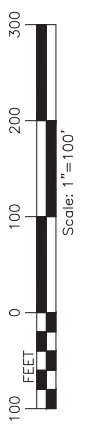

AR-1 ACCESS ROAD PROFILE
0+00 — 5+50
HORIZ: 1" = 100'
VERT: 1" = 50'

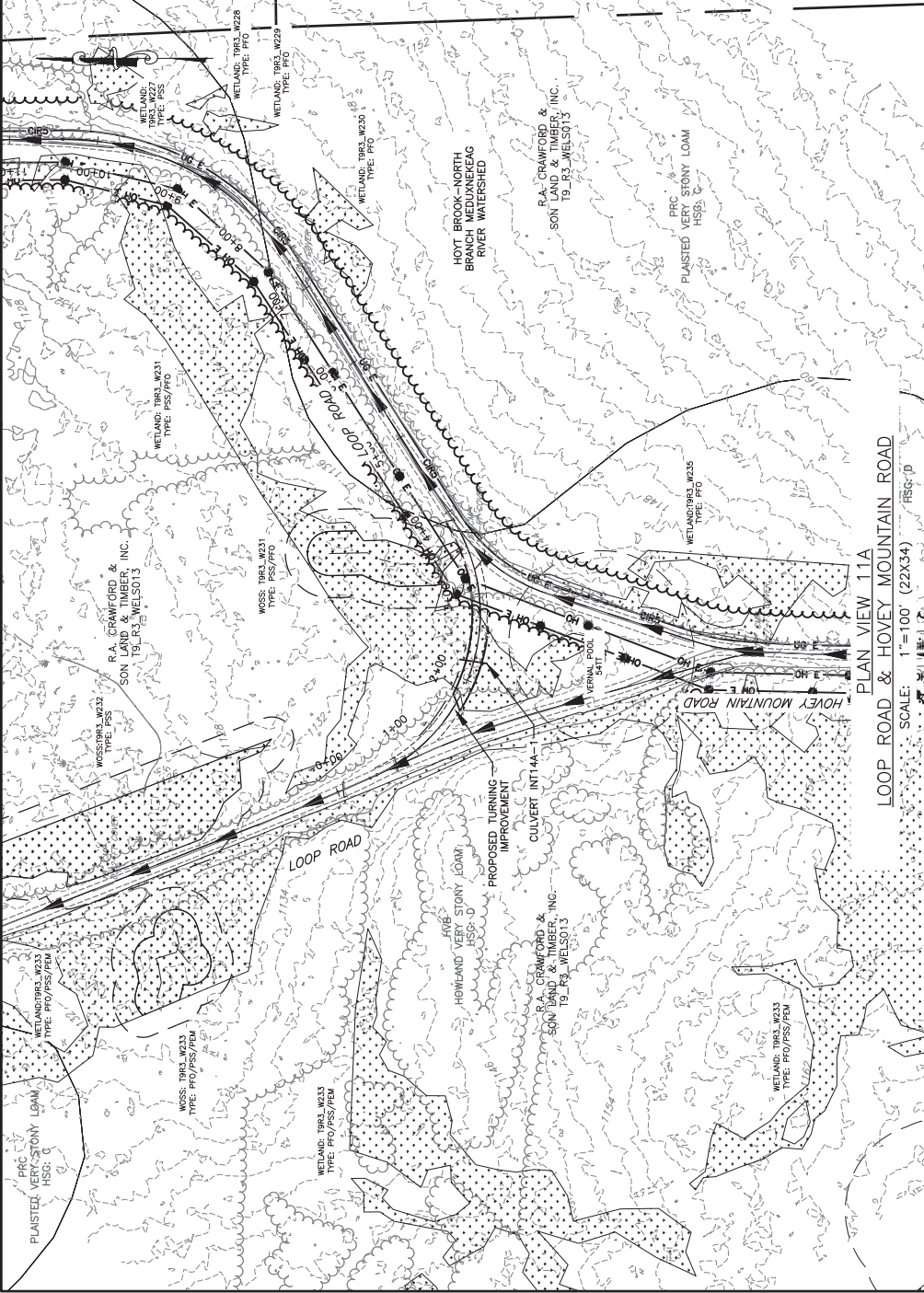

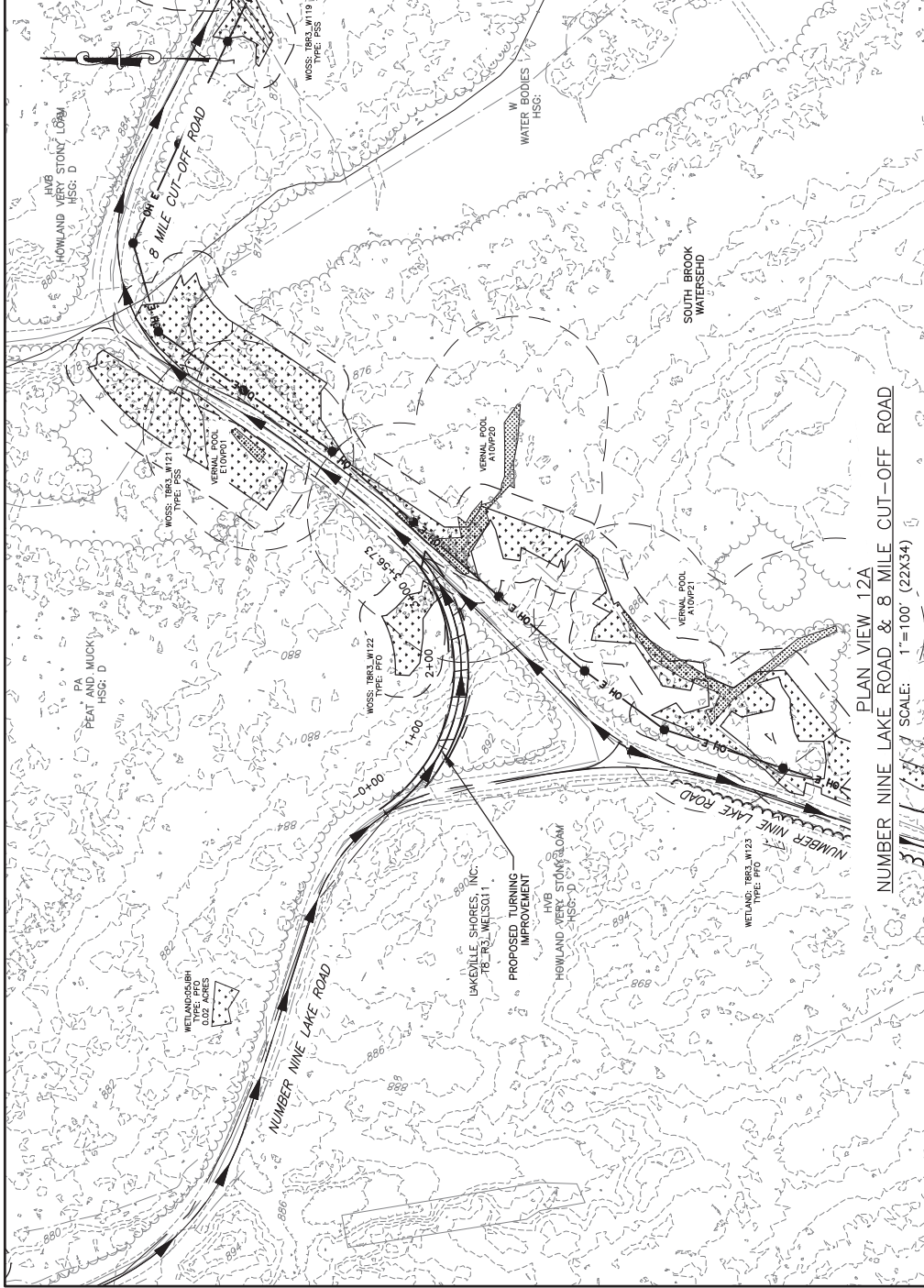

PLAN VIEW 12A
 NUMBER NINE LAKE ROAD & 8 MILE CUT-OFF ROAD
 SCALE: 1"=100' (22X34)

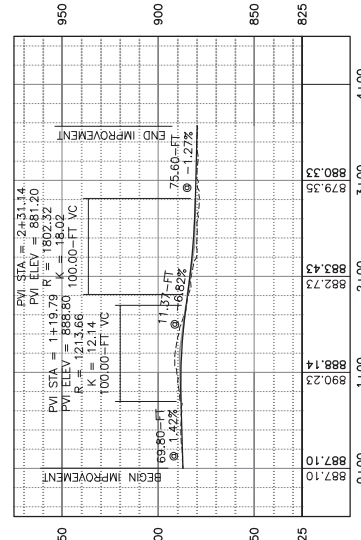

NUMBER NINE LAKE ROAD - 8 MILE CUT-OFF ROAD PROFILE
 0+00 - 3+56
 HORIZ: 1"=100'
 VERT: 1"=50'

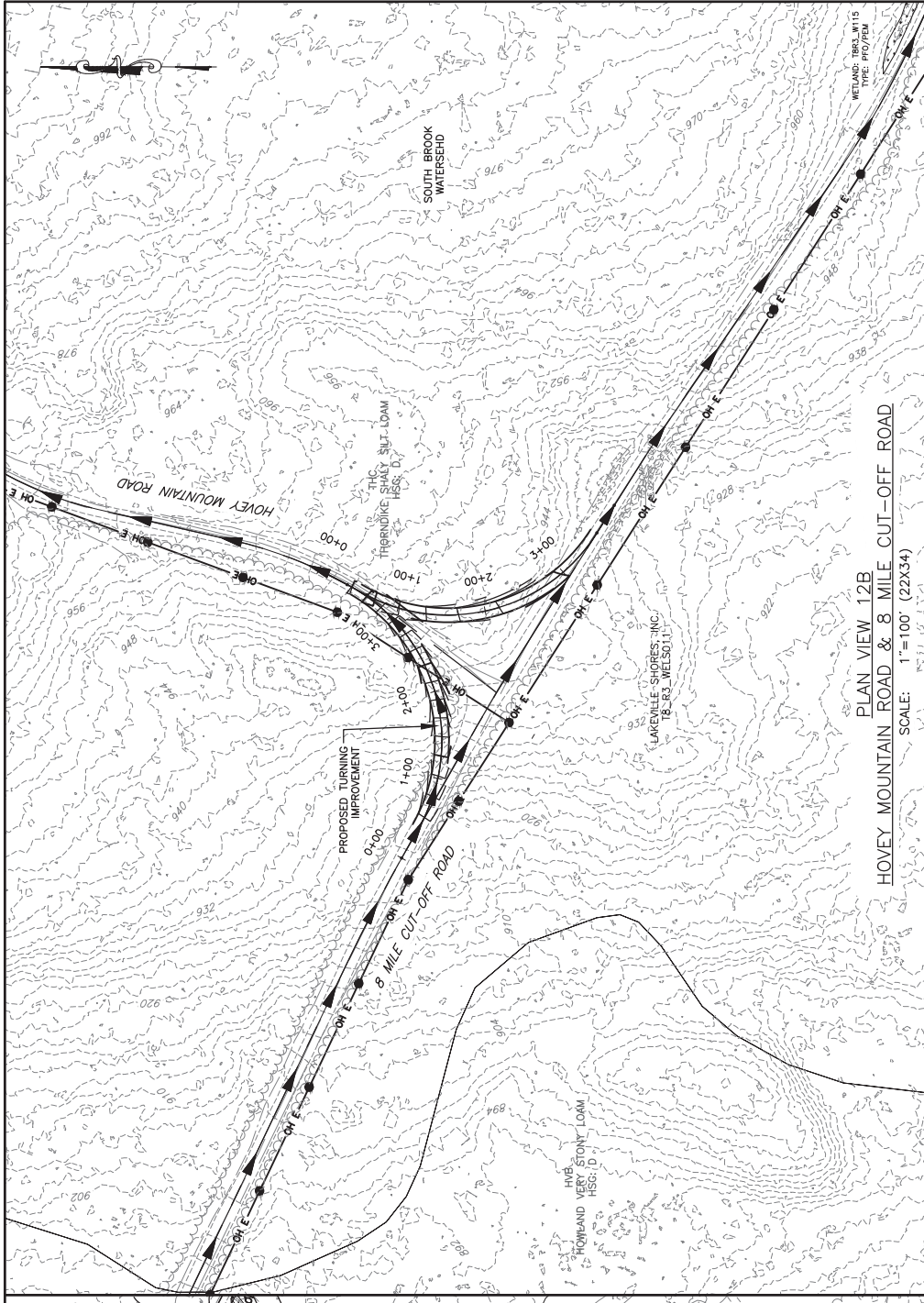

PLAN VIEW 12B
 HOVEY MOUNTAIN ROAD & 8 MILE CUT-OFF ROAD
 SCALE: 1"=100' (22X34)

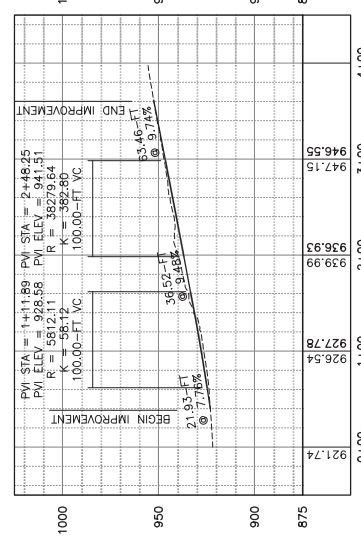

8 MILE CUT-OFF ROAD - HOVEY MOUNTAIN ROAD PROFILE
 0+40 - 3+60
 HORIZ: 1"=100'
 VERT: 1"=50'

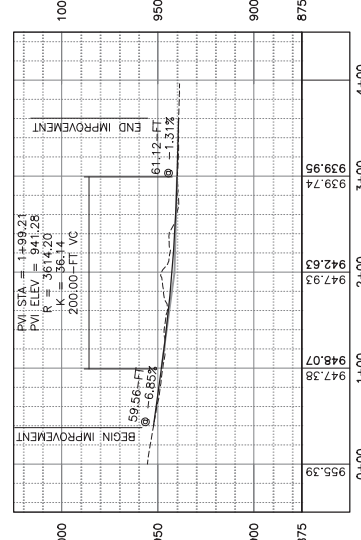

HOVEY MOUNTAIN ROAD - 8 MILE CUT-OFF ROAD PROFILE
 0+40 - 3+60
 HORIZ: 1"=100'
 VERT: 1"=50'

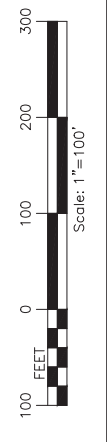

REV	DESCRIPTION	DATE	BY
1			
2			
3			
4			
5			
6			
7			

Copyright © 2014
 FISHER ASSOCIATES, P.E., L.L.C., P.C.
 This drawing was prepared by a member of the professional engineering or land surveying staff of Fisher Associates, P.E., L.L.C., P.C. It is intended for use only for the project and location shown hereon and is not to be used for any other project or location without the written consent of Fisher Associates, P.E., L.L.C., P.C.

FA PROJECT NO. 14009
 PROJECT MANAGER S. MELLOTT
 DRAWN BY DP/BA
 SCALE AS SHOWN
 ISSUE DATE JULY 2015

NUMBER NINE WIND FARM
 PRELIMINARY PLANS NOT FOR CONSTRUCTION
 AROOSTOOK COUNTY, MAINE
 INTERSECTION IMPROVEMENTS



PROJECT NUMBER NINE WIND FARM
 AROOSTOOK COUNTY, MAINE
 PRELIMINARY PLANS NOT FOR CONSTRUCTION
 INTERSECTION IMPROVEMENTS

DRAWING NO. INT-12
 SHEET 310 OF 338



REV	DESCRIPTION	DATE	BY
1			
2			
3			
4			
5			
6			
7			

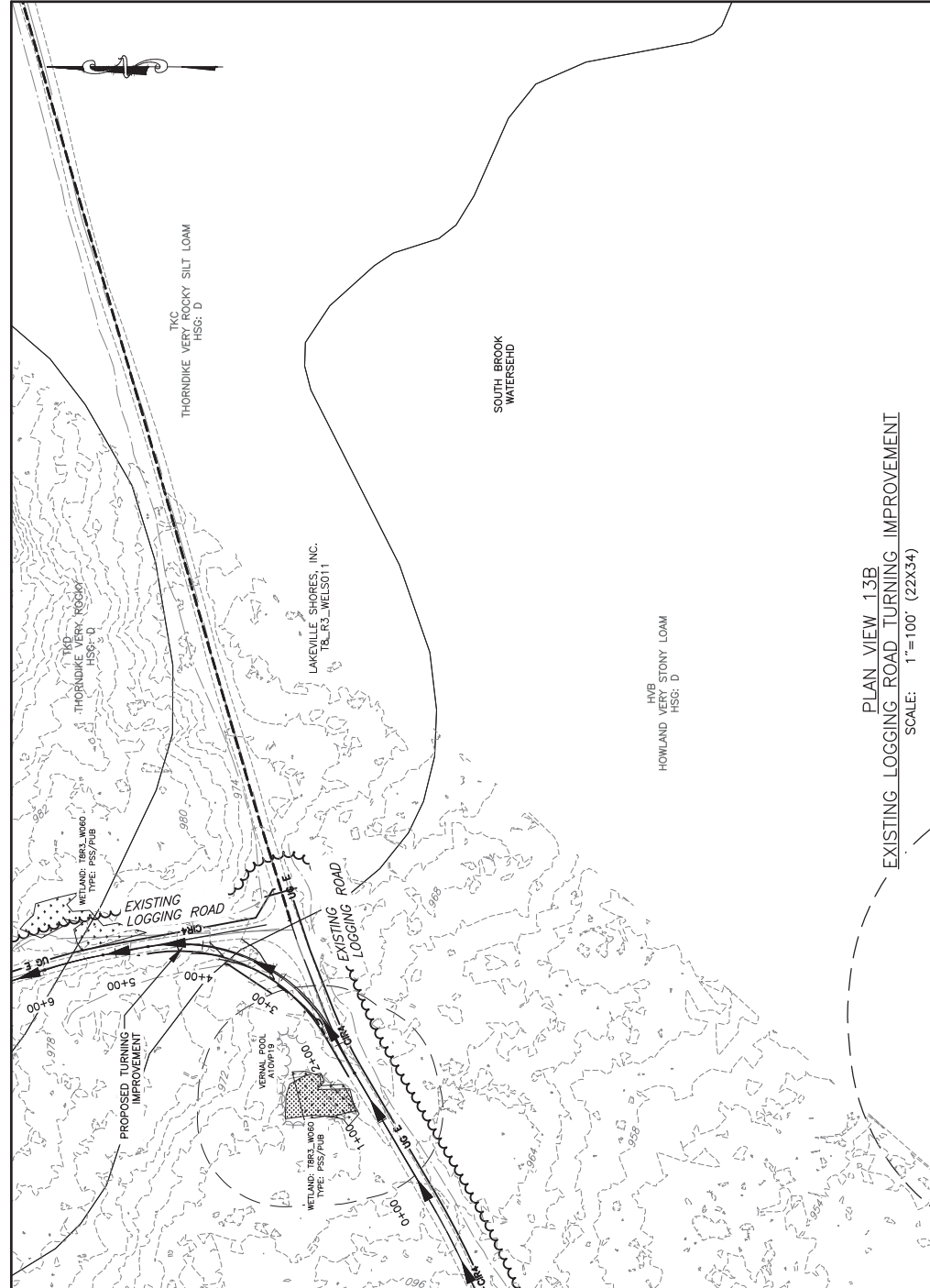

PLAN VIEW 13A
 8 MILE CUT-OFF ROAD & EXISTING LOGGING ROAD
 SCALE: 1"=100' (22X34)

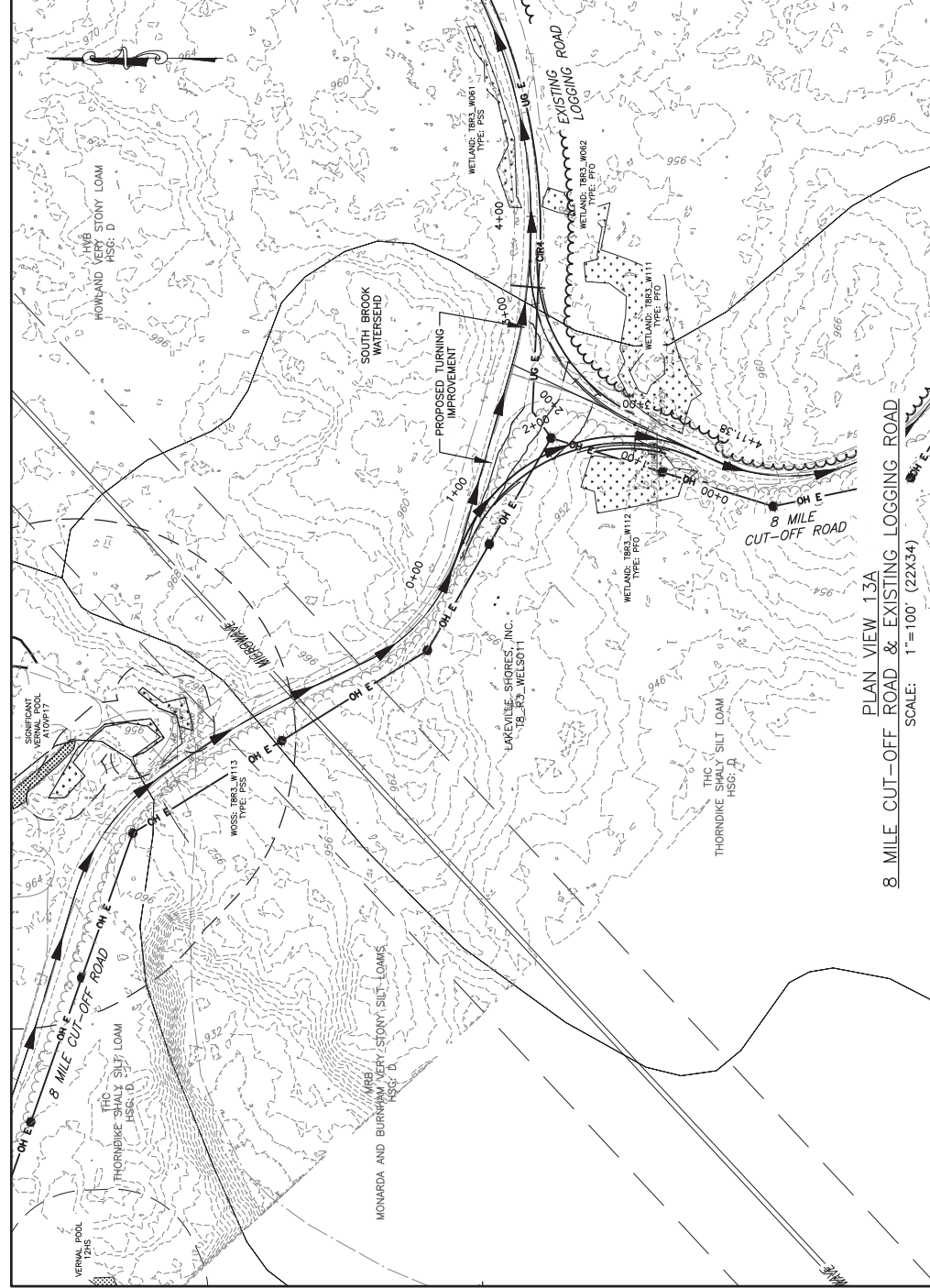

PLAN VIEW 13B
 EXISTING LOGGING ROAD TURNING IMPROVEMENT
 SCALE: 1"=100' (22X34)

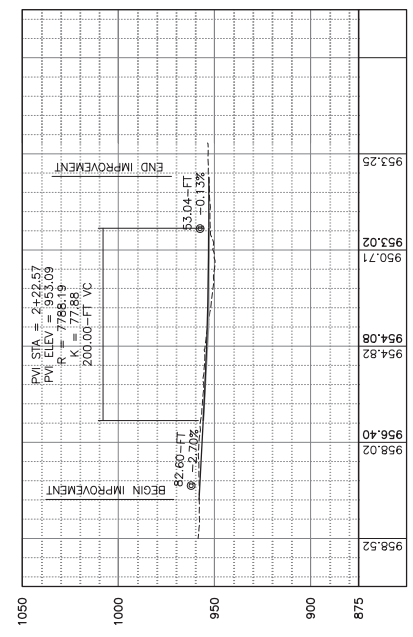

8 MILE CUT-OFF ROAD - 8 MILE CUT-OFF ROAD
 PROFILE
 0+40 - 3+75
 HORIZ: 1"=100'
 VERT: 1"=50'

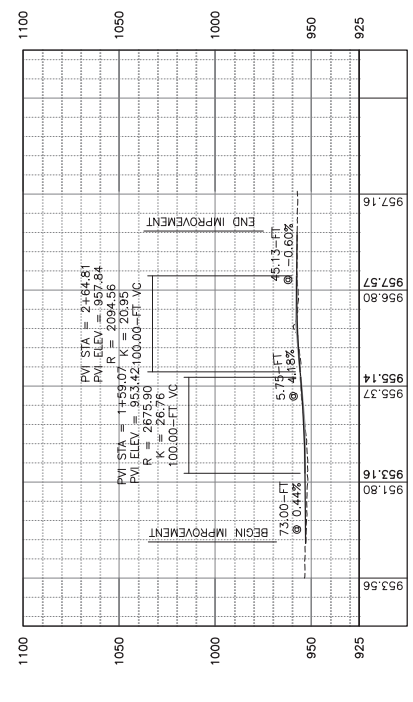

8 MILE CUT-OFF ROAD - EXISTING LOGGING ROAD PROFILE
 0+36 - 3+60
 HORIZ: 1"=100'
 VERT: 1"=50'

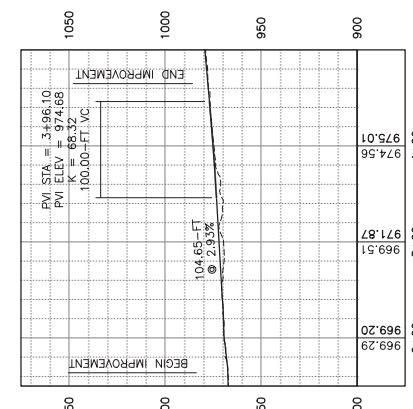

EXISTING LOGGING ROAD PROFILE
 1+64 - 4+65
 HORIZ: 1"=100'
 VERT: 1"=50'

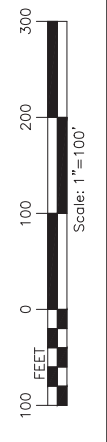



FA PROJECT NO.	140009		
PROJECT MANAGER	S. MELLOTT		
DRAWN BY	DP/BA		
SCALE	AS SHOWN		
ISSUE DATE	JULY 2015		
COPYRIGHT © 2014 FISHER ASSOCIATES, P.E., L.L.C., L.A., P.C. This firm is a registered professional engineering firm in the State of Maine and is a holder of a license to practice in the State of Maine. It is not to be used for any other purpose without the written consent of the firm. The design engineer or his/her representative shall be responsible for the design and construction of the project. The design engineer or his/her representative shall be responsible for the design and construction of the project. The design engineer or his/her representative shall be responsible for the design and construction of the project.			
REV	DESCRIPTION	DATE	BY
1			
2			
3			
4			
5			
6			
7			

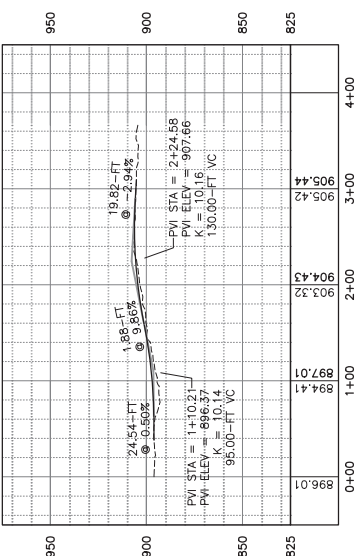
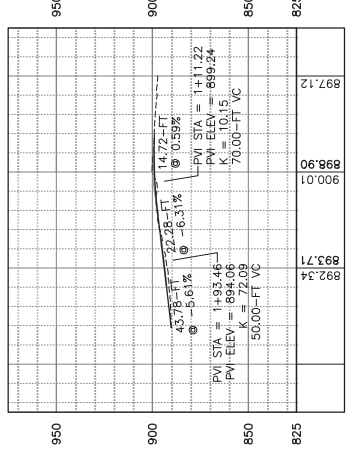
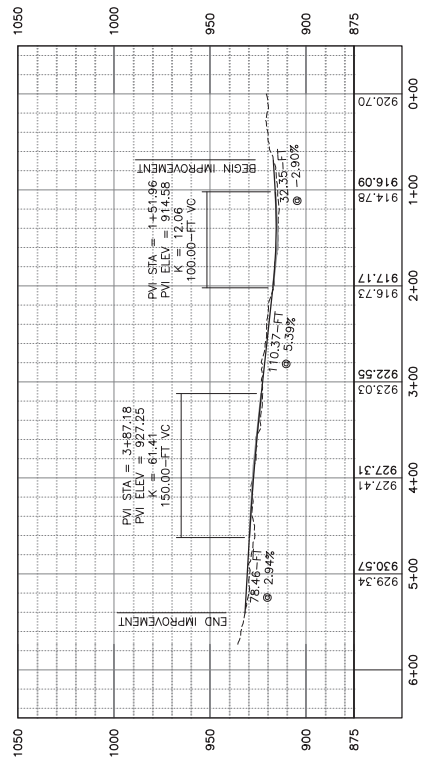
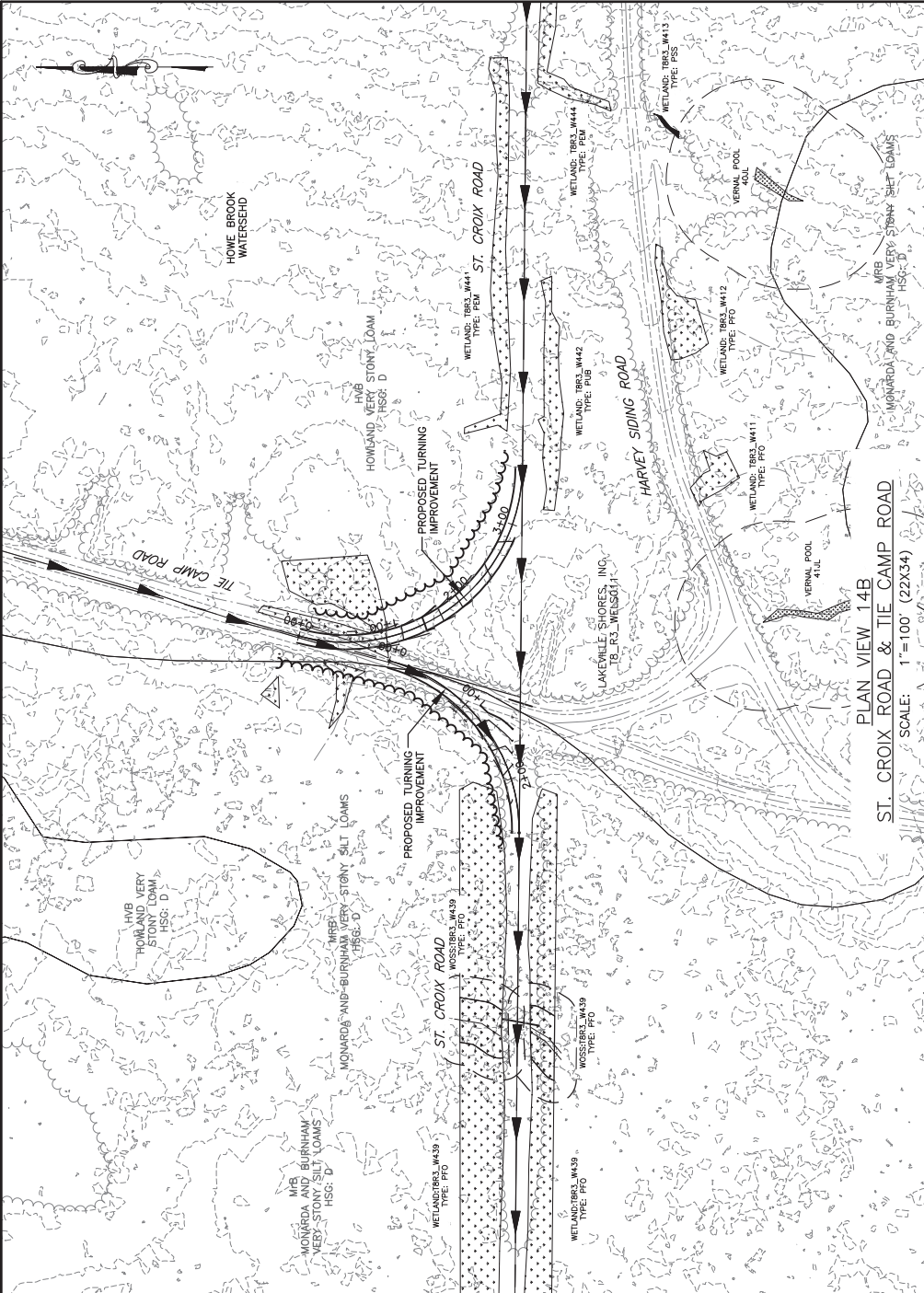
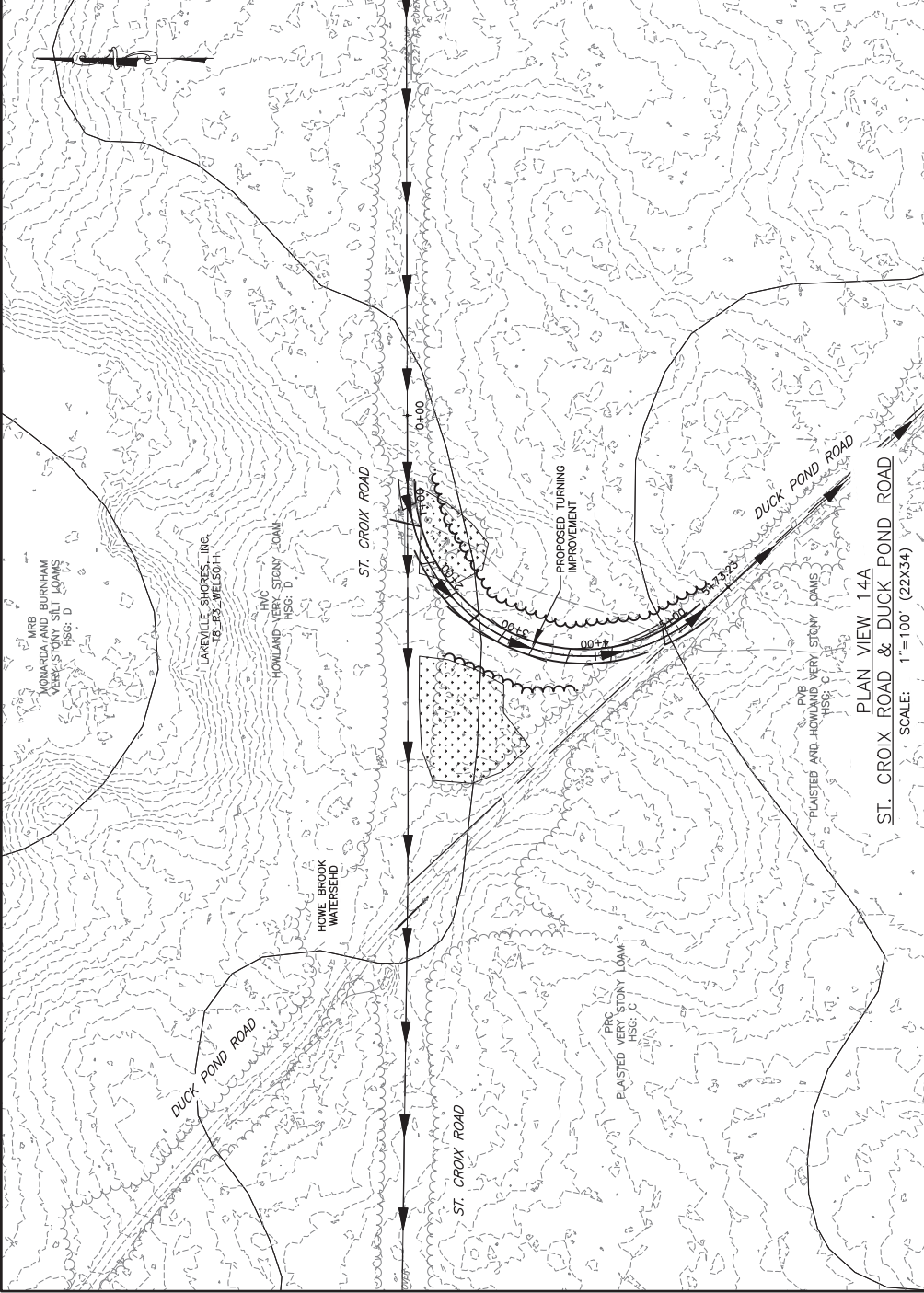

INT-15

DRAWING NO.

PROJECT
 NUMBER NINE WIND FARM
 AROOSTOOK COUNTY, MAINE
 PRELIMINARY PLANS NOT FOR CONSTRUCTION
 INTERSECTION IMPROVEMENTS



FA PROJECT NO. 140009
 PROJECT MANAGER S. MELLOTT
 DRAWN BY DP/BA
 SCALE AS SHOWN
 ISSUE DATE JULY 2015

REV	DESCRIPTION	DATE	BY
1			
2			
3			
4			
5			
6			
7			

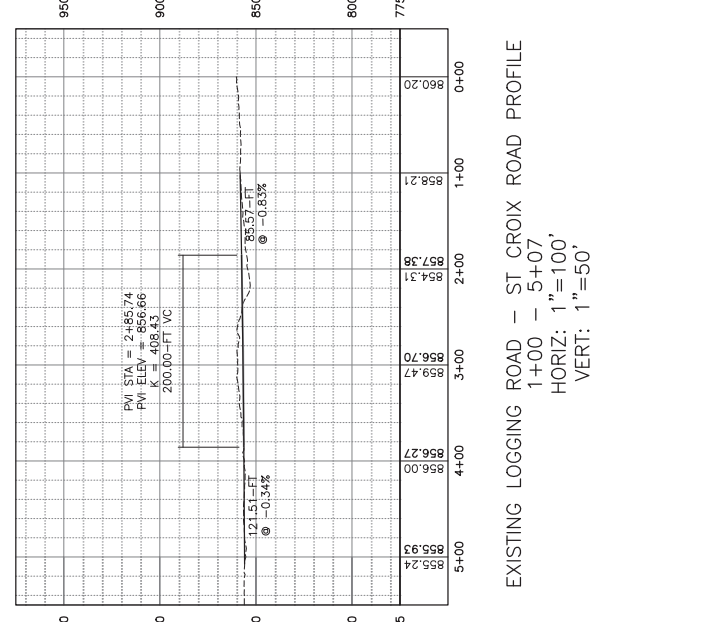
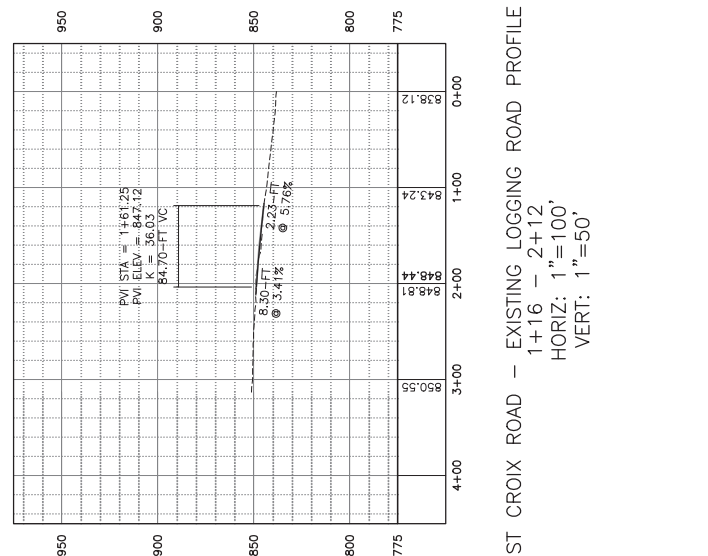
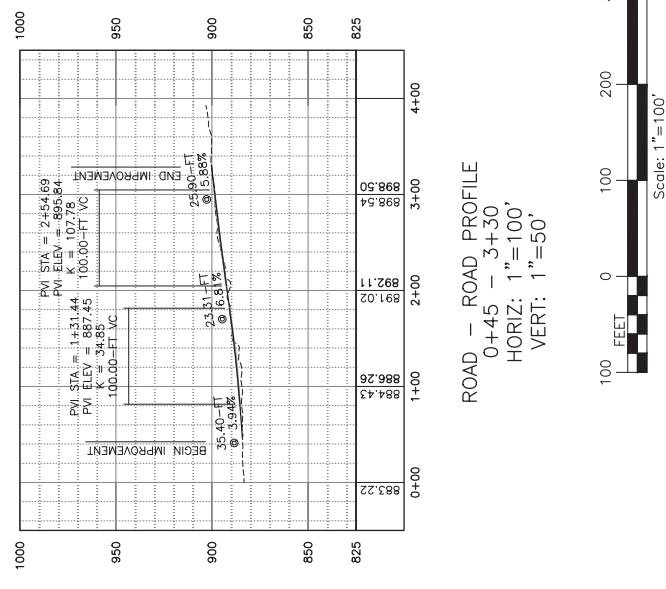
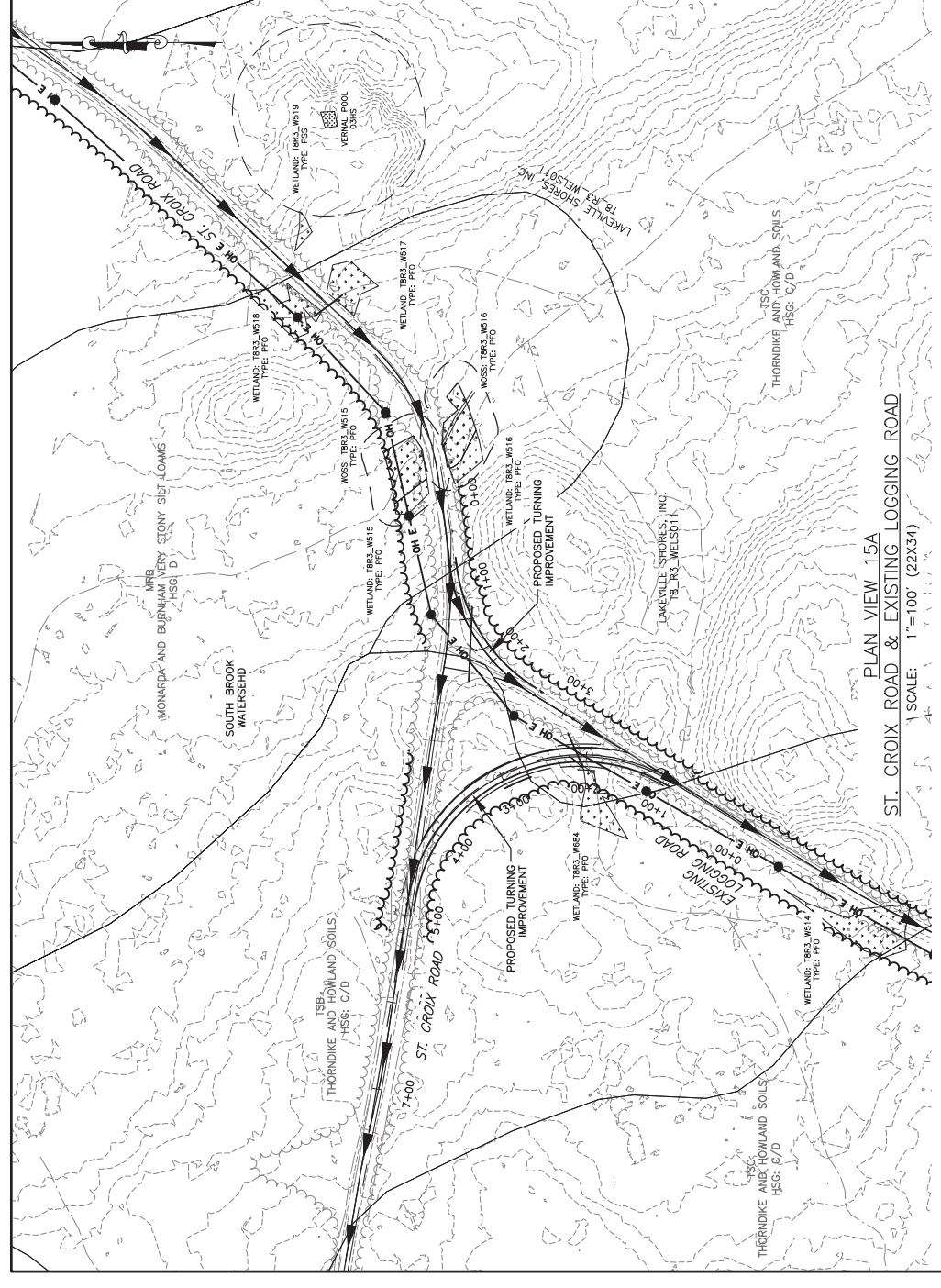
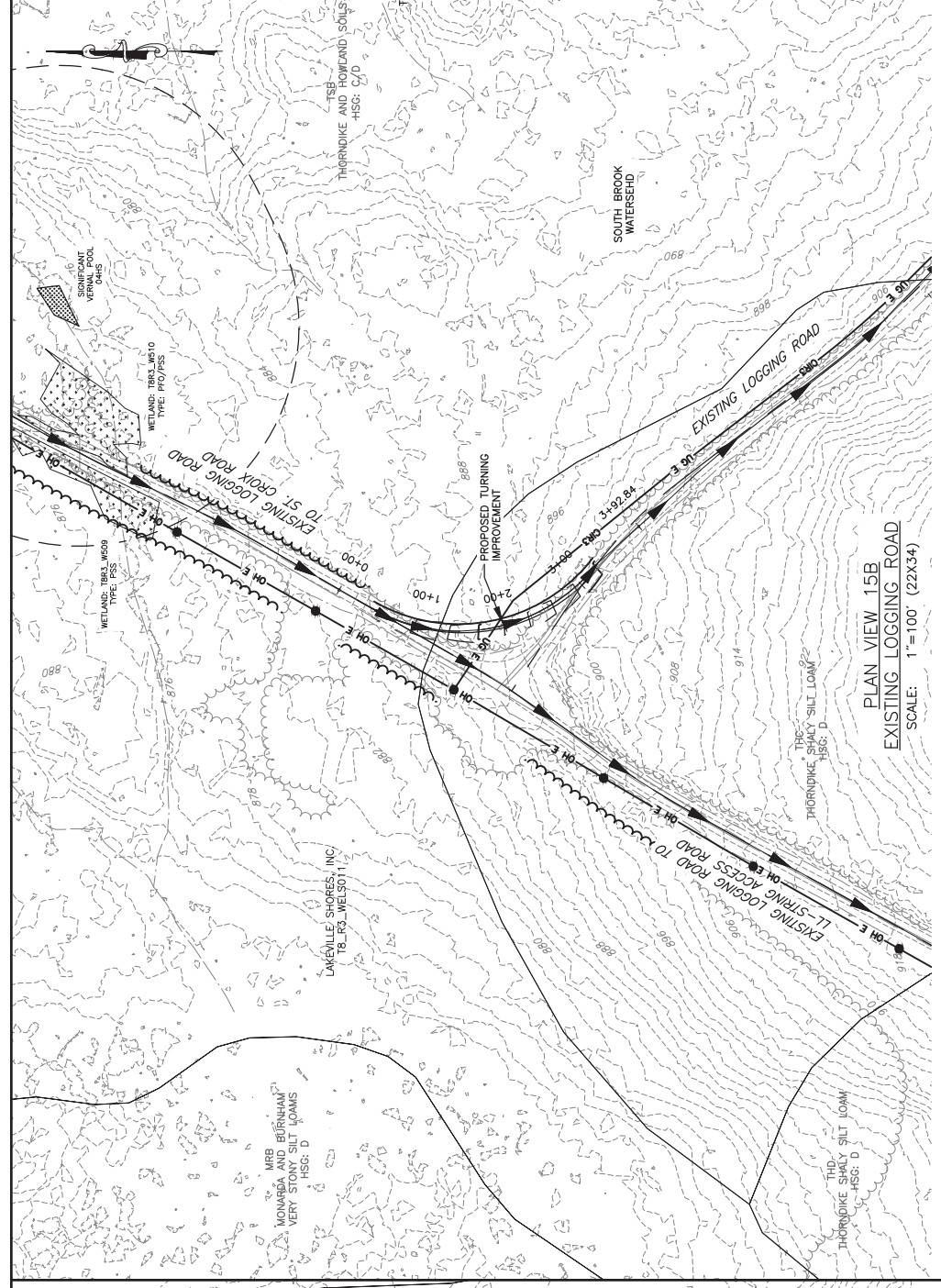

INT-16

DRAWING NO.

PROJECT
 NUMBER NINE WIND FARM
 AROOSTOOK COUNTY, MAINE
 PRELIMINARY PLANS NOT FOR CONSTRUCTION
 INTERSECTION IMPROVEMENTS



FA PROJECT NO.
 140009
 PROJECT MANAGER
 S. MELLOTT
 DRAWN BY
 DP/BA
 SCALE
 AS SHOWN
 ISSUE DATE
 JULY 2015

COPYRIGHT © 2014
 FISHER ASSOCIATES, P.E., L.A., P.C.
 This drawing shall be a violation of the New York State Education Law Section 2203 unless used in a location of an acting professional engineer or land surveyor, after an item in any way. If you borrow the use of this drawing, you agree that the use of this drawing is limited to the specific description of the location, and a specific description of the location, and a specific description of the location.

REV	DESCRIPTION	DATE	BY
1			
2			
3			
4			
5			
6			
7			

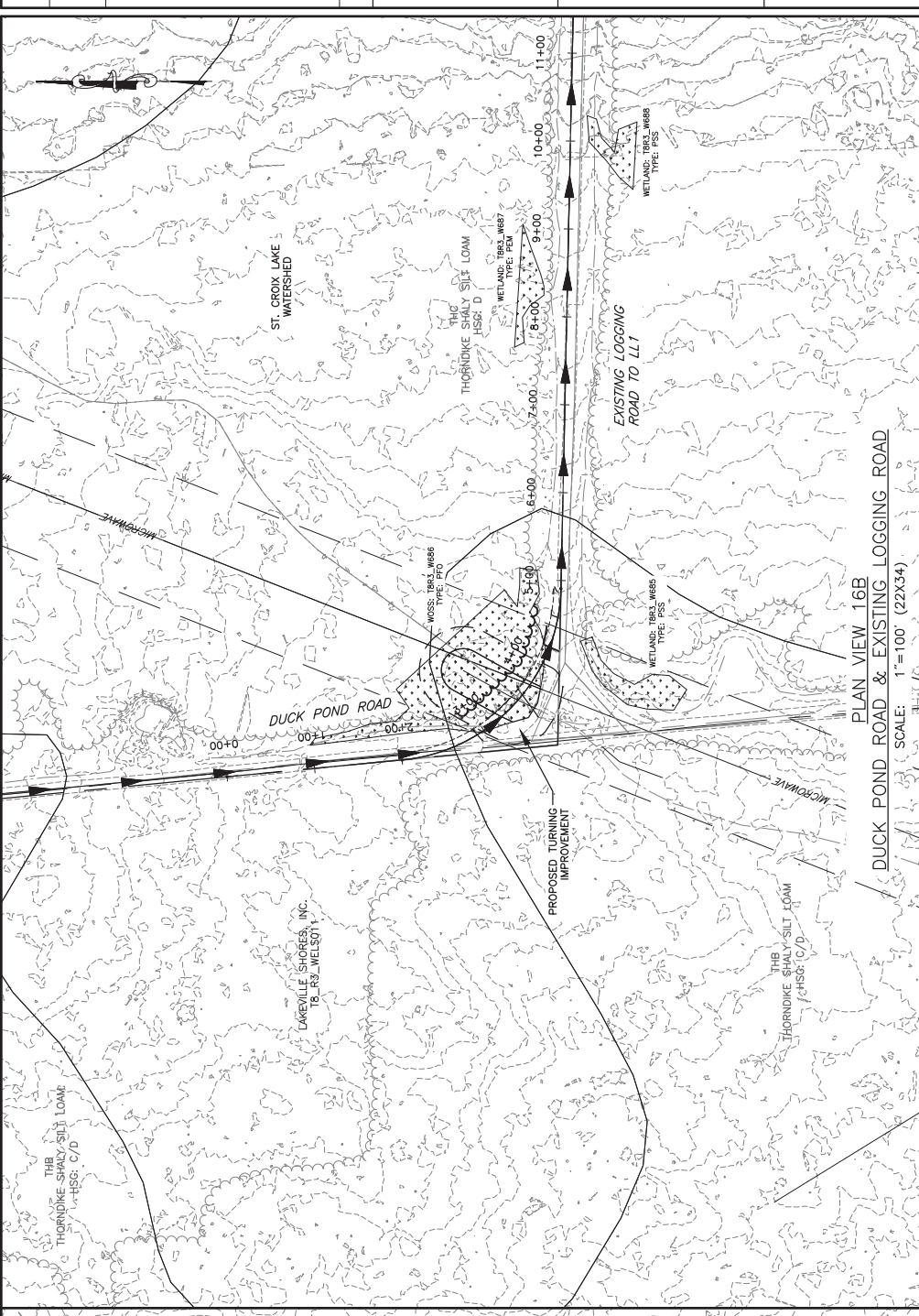

PLAN VIEW 16A
 EXISTING LOGGING ROAD TURNING IMPROVEMENT
 SCALE: 1"=100' (22X34)

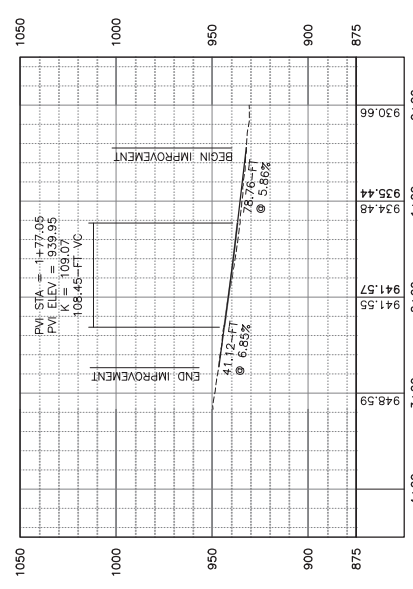

ROAD - ROAD PROFILE
 0+45 - 2+70
 HORIZ: 1"=100'
 VERT: 1"=50'

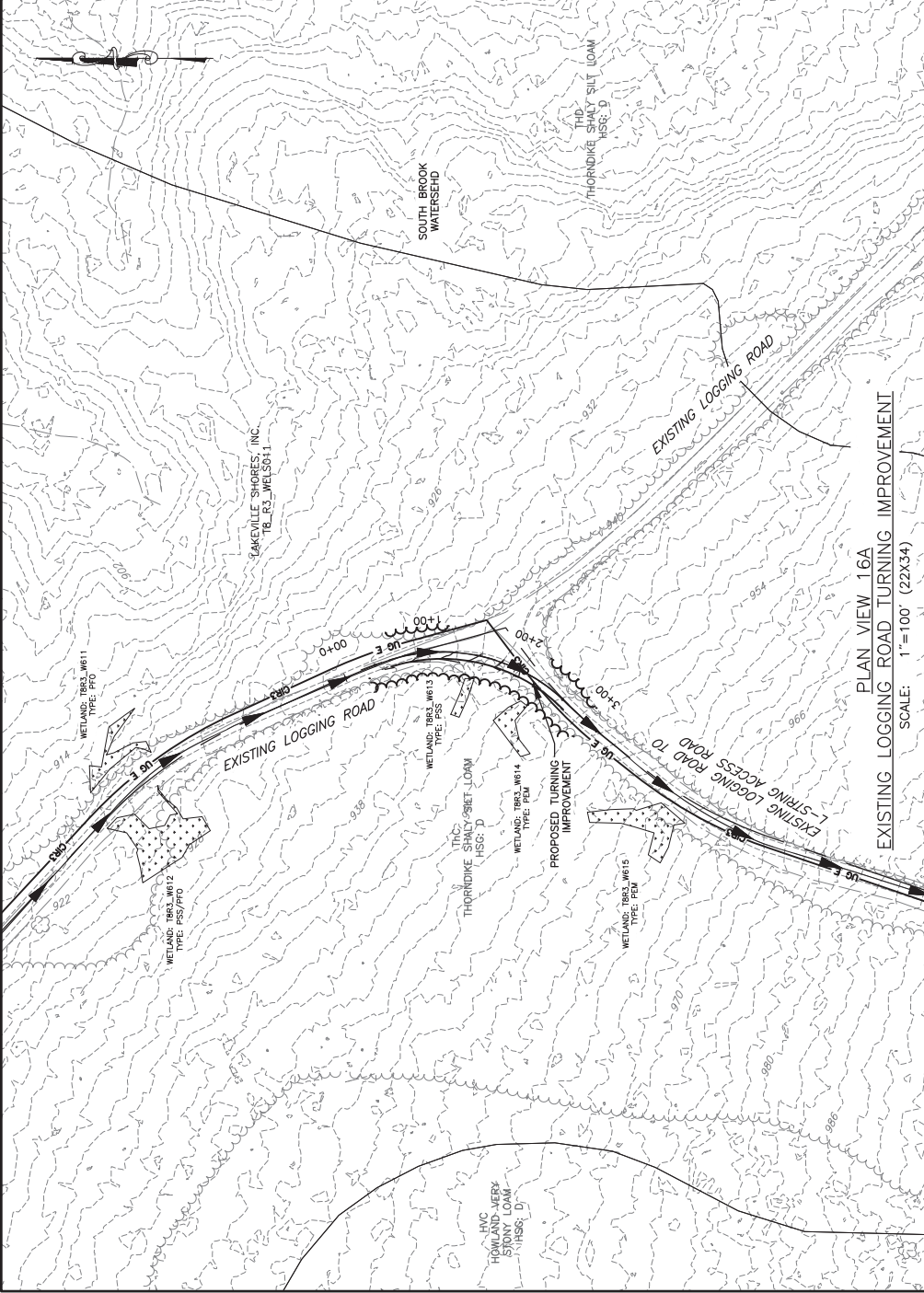

PLAN VIEW 16B
 DUCK POND ROAD & EXISTING LOGGING ROAD
 SCALE: 1"=100' (22X34)

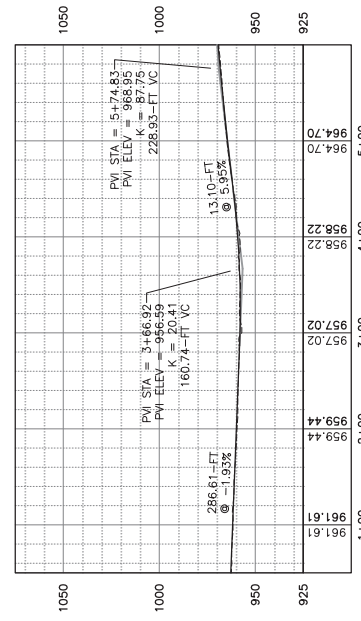

ROAD - ROAD PROFILE
 0+45 - 2+70
 HORIZ: 1"=100'
 VERT: 1"=50'

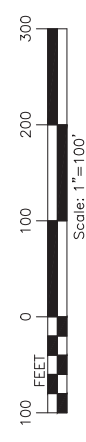

REV	DESCRIPTION	DATE	BY
1			
2			
3			
4			
5			
6			
7			

FA PROJECT NO. 14009
 PROJECT MANAGER S. MELLOTT
 DRAWN BY DP/BA
 SCALE AS SHOWN
 ISSUE DATE JULY 2015

NUMBER NINE WIND FARM
 AROOSTOOK COUNTY, MAINE
 PRELIMINARY PLANS NOT FOR CONSTRUCTION
 INTERSECTION IMPROVEMENTS

PROJECT
 NUMBER NINE WIND FARM
 AROOSTOOK COUNTY, MAINE
 PRELIMINARY PLANS NOT FOR CONSTRUCTION
 INTERSECTION IMPROVEMENTS



DRAWING NO. INT-17
 SHEET 315 OF 338

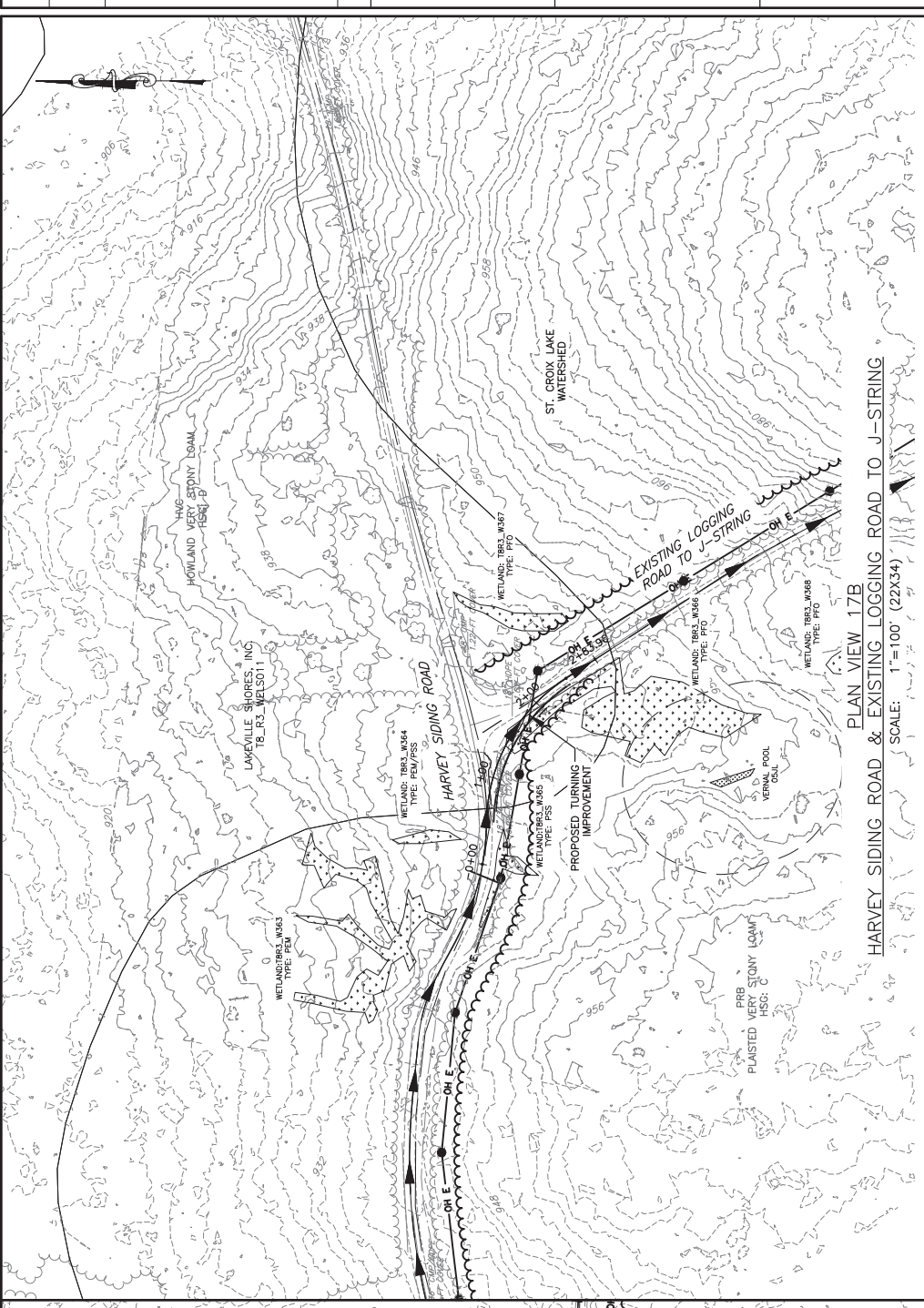

PLAN VIEW 17A
 BLACK FRY ROAD & HARVEY SIDING ROAD
 SCALE: 1"=100' (22X34)

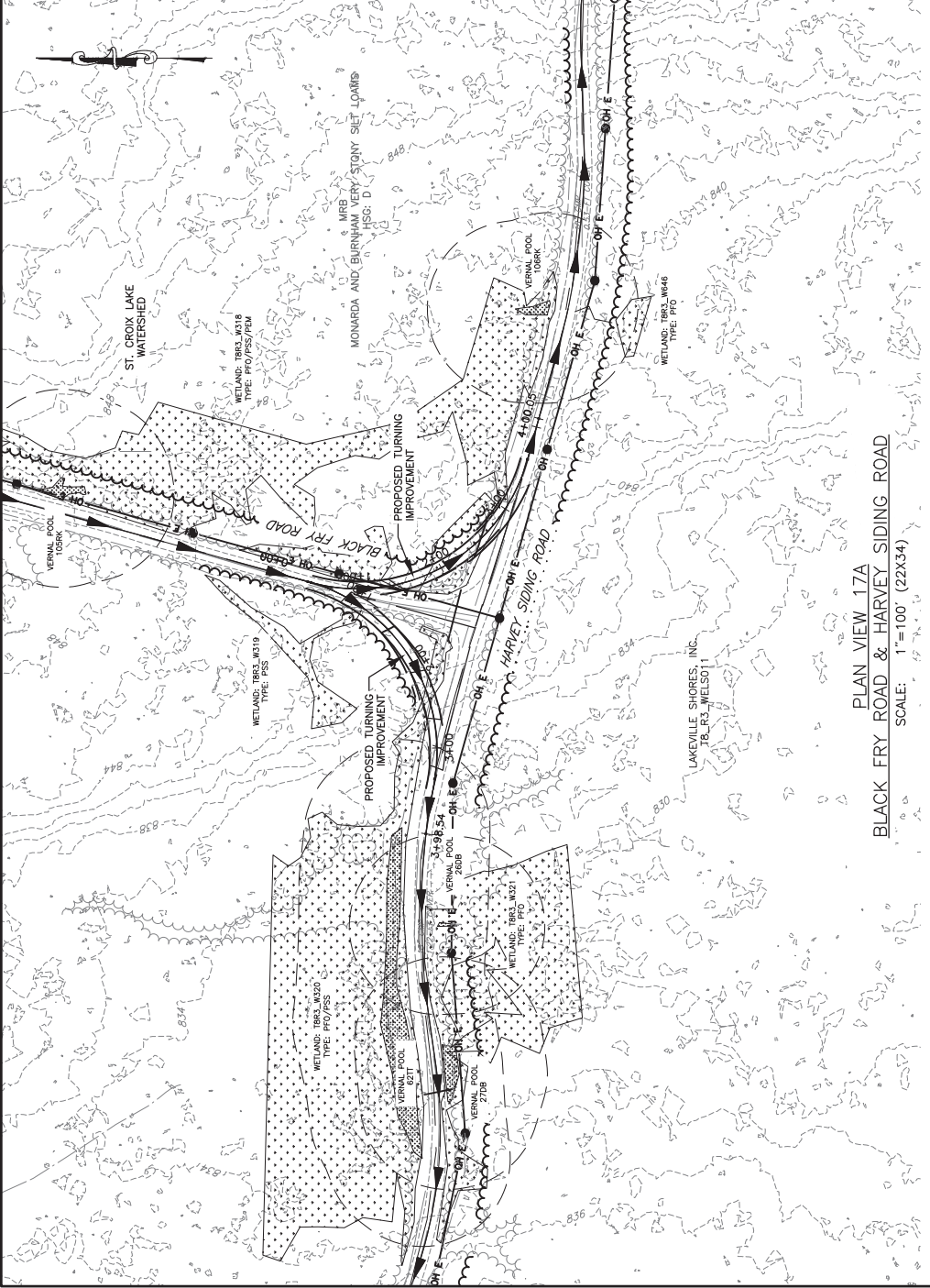

PLAN VIEW 17B
 HARVEY SIDING ROAD & EXISTING LOGGING ROAD TO J-STRING
 SCALE: 1"=100' (22X34)

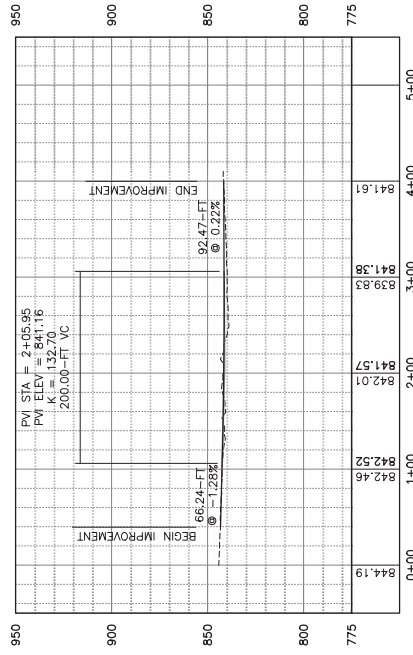

BLACK FRY ROAD - HARVEY SIDING ROAD
 RIGHT PROFILE
 0+40 - 4+00
 HORIZ: 1"=100'
 VERT: 1"=50'

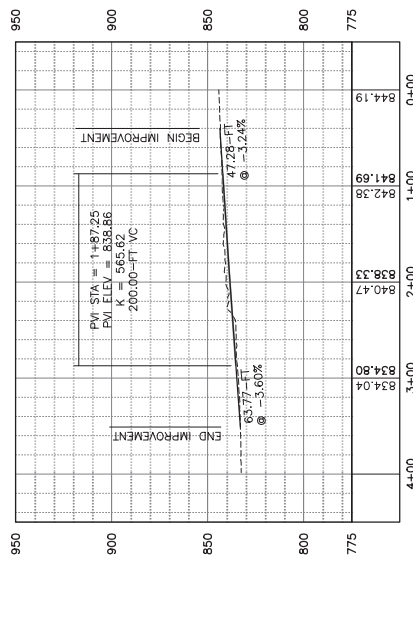

BLACK FRY ROAD - HARVEY SIDING ROAD
 LEFT PROFILE
 0+40 - 3+50
 HORIZ: 1"=100'
 VERT: 1"=50'

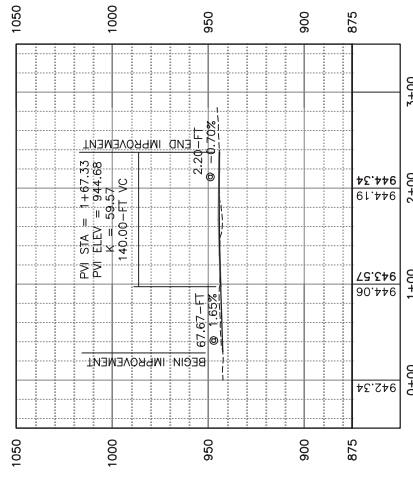

HARVEY SIDING ROAD - EXISTING LOGGING ROAD PROFILE
 0+50 - 2+40
 HORIZ: 1"=100'
 VERT: 1"=50'

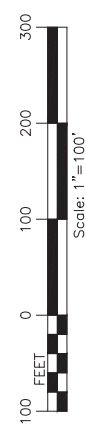

PROJECT
 NUMBER NINE WIND FARM
 AROOSTOOK COUNTY, MAINE
 PRELIMINARY PLANS NOT FOR CONSTRUCTION

TITLE OF DRAWINGS
 HOVEY MOUNTAIN ROAD BRIDGE



FISHER ASSOCIATES
 130 Colburn Road, Rochester, NY 14623
 Phone: 585-534-1310

FA PROJECT NO.
 140009
 PROJECT MANAGER
 S. MELLOTT
 DRAWN BY
 DP/BA
 SCALE
 AS SHOWN
 ISSUE DATE
 JULY 2015

Copyright © 2014
 FISHER ASSOCIATES, P.E., L.A., P.C.

This drawing was prepared by a Licensed Professional Engineer or Land Surveyor, after an examination of the original field notes and a verification of the accuracy of the data furnished to the drafter. The drafter of this drawing is not responsible for the accuracy of the data furnished to the drafter, nor for the accuracy of the field notes or other data upon which this drawing is based.

REV	DESCRIPTION	DATE	BY
1			
2			
3			
4			
5			
6			
7			

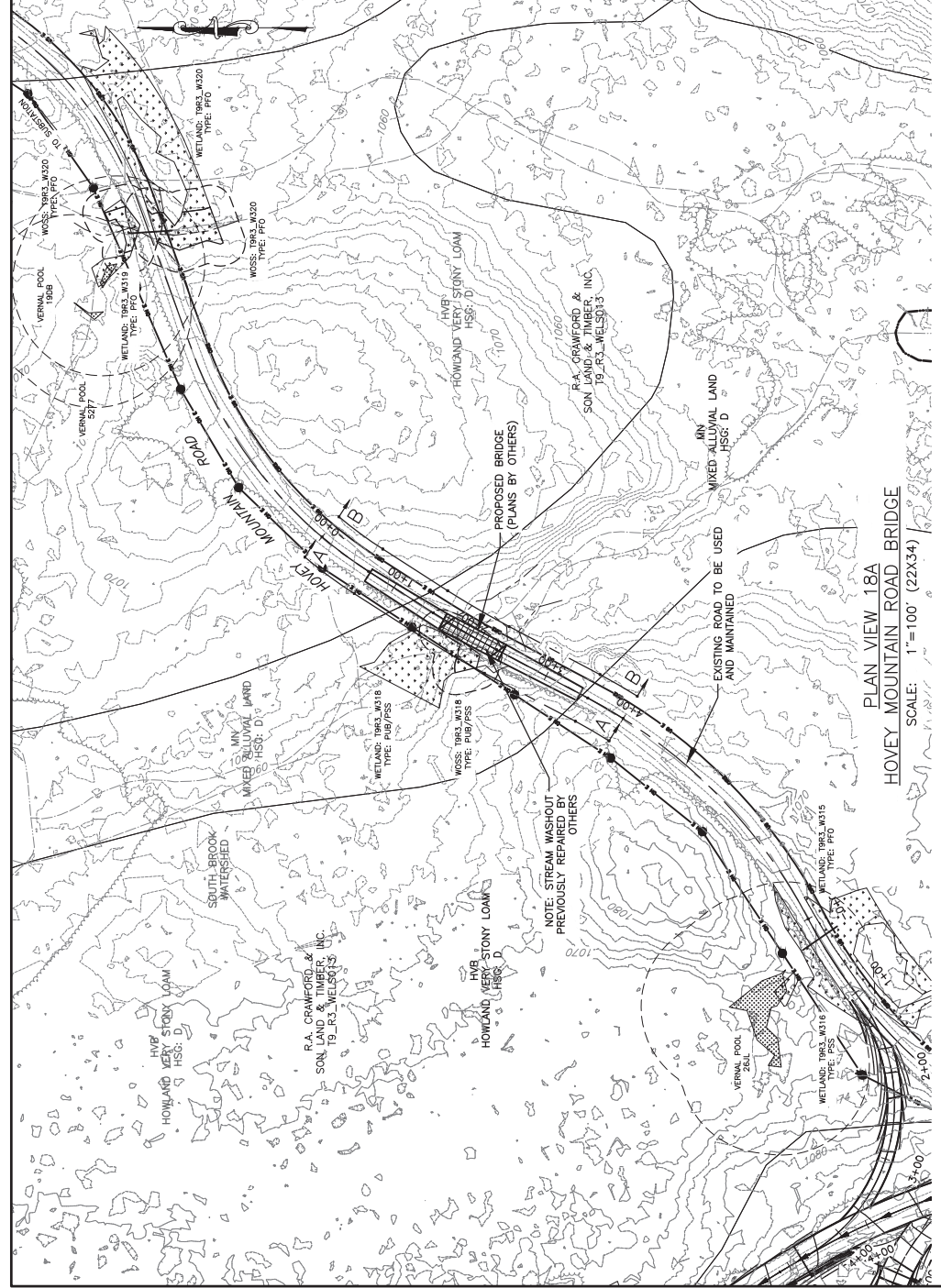
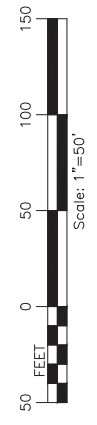

PLAN VIEW 18A
 HOVEY MOUNTAIN ROAD BRIDGE
 SCALE: 1"=100' (22X34)

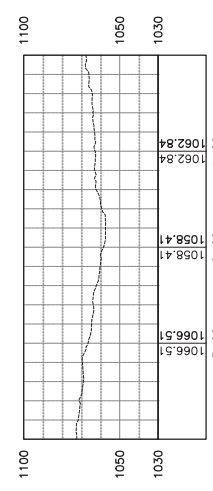

HOVEY MOUNTAIN ROAD SECTION A-A
 HORIZ: 1"=10'
 VERT: 1"=5'

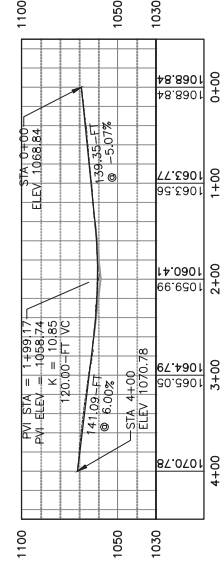

CENTERLINE HOVEY MOUNTAIN RD
 HORIZ: 1"=10'
 VERT: 1"=5'

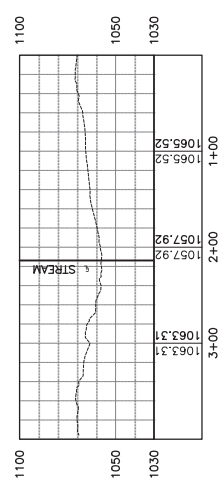

HOVEY MOUNTAIN ROAD SECTION B-B
 HORIZ: 1"=10'
 VERT: 1"=5'