



STATE OF MAINE
DEPARTMENT OF TRANSPORTATION
16 STATE HOUSE STATION
AUGUSTA, MAINE 04333-0016

Paul R. LePage
GOVERNOR

David Bernhardt
COMMISSIONER

July 8, 2011
Subject: **Portland Marine Terminal**
Federal Project No: DTMA1G10006/TIGER
State PIN: 017820.00
Amendment No. 4

Dear Sir/Ms:

Make the following change to the Bid Document:

In the Bid Book (pages 6 thru 17) **REMOVE** the "SCHEDULE OF ITEMS" 12 pages dated 110707 (replaced in Amendment #3) and **REPLACE** with the attached new "SCHEDULE OF ITEMS" 12 pages dated 110708.

The following questions have been received:

Question: On Sheet A.A1, the Security Office has a type W1 and type W2 window. These windows are not shown on the window schedule or the door and frame schedule. Please clarify.

Response: Interior windows "W1" and "W2" are shown on the Ground Floor Plan on Sheet A.A1 and on interior elevations A/A.A12, 4/A.A13, and 1/A.A13 but they do not appear on the door and frame schedule on Sheet A.A9.

W1 is a fixed glass unit with hollow metal frame as shown in the attached sketch.

W2 is a hollow metal frame with sliding glass panels as shown in the attached sketch.

Question: Reference drawing A.A1 in room 107 "Entry" – there are several items shown on the walls (North and West), what is indicated? These items are also shown on the interior elevation 2-2 and 2b on Plan Sheet A.A12.

Response: The items shown on the interior elevations of entry 107 are a built-in bench and a built-in overhead with coat hooks. The bench is described in Detail 4 on Sheet A.A10 and the clear finished wood referenced in the notes refers to maple. A detail of the shelf was not provided. See attached sketch for shelf detail.



PRINTED ON RECYCLED PAPER

Question: The new chain link fence at the new port office, which bid item is that covered under?

Response: Pay Item 607.25, Remove and Reset Chain Link Fence.

Question: Plan Sheet C27 detail 1 – New Pavement Detail lists various thicknesses of HMA, Gravel Base Type A and Gravel Subbase Type D for the 3 different buildup sections. The schedule of items only has item 304.104 Aggregate Subbase Course Gravel (plan quantity). Is the gravel base incidental to item 304.104?

Response: The Gravel Base Type A is not incidental to 304.104. Gravel Base Type A was mistakenly omitted from the Schedule of Items, and is now included herein as Pay Item 304.09 at a quantity of 4,300 cy.

Question: Reference bid items 823.3235, 823.33 and 823.335. With 6 Tapping Sleeve & Gate Valves we do not find where the 4 – 6” Gate Valves and 2 of the 3 – 4” Gate Valves will be installed. Please clarify.

Response: The two relocated hydrants each receive a 6" gate valve. The 6" fire protection service receives a 6" gate valve at the Tee to the office building, and at the Tee to the Maintenance Building. The 4" domestic water service receives a 4" gate valve at the Tee to the office building; at the Tee to the Maintenance Building; and exiting the Maintenance Building toward the pier water service.

Consider this change and information prior to submitting your bid on July 13, 2011.

Sincerely,



Scott Bickford
Contracts & Specifications Engineer

SCHEDULE OF ITEMS

REVISED:

CONTRACT ID: 017820.00

PROJECT(S): DTMA1G10006 / TIGER+S

CONTRACTOR : _____

LINE NO	ITEM DESCRIPTION	APPROX. QUANTITY AND UNITS	UNIT PRICE		BID AMOUNT	
			DOLLARS	CTS	DOLLARS	CTS
SECTION 0001 PROJECT ITEMS						
0010	201.23 REMOVING SINGLE TREE TOP ONLY	14.000 EA				
0020	202.01 REMOVING STRUCTURES AND OBSTRUCTIONS	LUMP	LUMP			
0030	202.078 REMOVING ASBESTOS CONTAINING MATERIAL	LUMP	LUMP			
0040	202.08 REMOVING BUILDING NO.: IMT BLD.	LUMP	LUMP			
0050	202.08 REMOVING BUILDING NO.: PORT OFFICE TRAILER	LUMP	LUMP			
0060	202.08 REMOVING BUILDING NO.: TRUCK INSPECTION TRAILER	LUMP	LUMP			
0070	202.08 REMOVING BUILDING NO.: US CUSTOMS BLD.	LUMP	LUMP			
0080	202.1221 REMOVE ABANDONED CONCRETE FOUNDATION FOUNDATION	LUMP	LUMP			
0090	202.1241 REMOVING CONCRETE SLAB MAINTENANCE BLD.	LUMP	LUMP			
0100	202.15 REMOVING MANHOLE OR CATCH BASIN	14.000 EA				

SCHEDULE OF ITEMS

REVISED:

CONTRACT ID: 017820.00

PROJECT(S): DTMA1G10006 / TIGER+S

CONTRACTOR : _____

LINE NO	ITEM DESCRIPTION	APPROX. QUANTITY AND UNITS	UNIT PRICE		BID AMOUNT	
			DOLLARS	CTS	DOLLARS	CTS
0110	202.203 PAVEMENT BUTT JOINTS	450.000 SY				
0120	202.2111 REMOVING, STORING, AND RESETTING OBJECTS	1.000 EA				
0130	202.4011 REMOVING EMBEDDED TIMBER PILE	5.000 EA				
0140	203.20 COMMON EXCAVATION	5450.000 CY				
0150	203.24 COMMON BORROW	50.000 CY				
0160	206.085 STRUCTURAL EARTH EXCAVATION - WATERFRONT	120.000 CY				
0170	304.09 AGGREGATE BASE COURSE - CRUSHED	4300.000 CY				
0180	304.104 AGGREGATE SUBBASE COURSE (PLAN QUANTITY)	8050.000 CY				
0190	403.207 HOT MIX ASPHALT 19.0 MM HMA	5450.000 T				
0200	403.208 HOT MIX ASPHALT 12.5 MM HMA SURFACE	3750.000 T				
0210	409.15 BITUMINOUS TACK COAT - APPLIED	1100.000 G				

SCHEDULE OF ITEMS

REVISED:

CONTRACT ID: 017820.00

PROJECT(S): DTMA1G10006 / TIGER+S

CONTRACTOR : _____

LINE NO	ITEM DESCRIPTION	APPROX. QUANTITY AND UNITS	UNIT PRICE		BID AMOUNT	
			DOLLARS	CTS	DOLLARS	CTS
0220	419.30 SAW CUTTING BITUMINOUS PAVEMENT	810.000 LF				
0230	501.231 DYNAMIC LOADING TEST	3.000 EA				
0240	501.70 STEEL PIPE PILES, DELIVERED 16" DIA	3816.000 LF				
0250	501.701 STEEL PIPE PILES, IN PLACE 16" DIA.	3708.000 LF				
0260	501.90 PILE TIPS	36.000 EA				
0270	501.91 PILE SPLICES	9.000 EA				
0280	501.92 PILE DRIVING EQUIPMENT MOBILIZATION	LUMP	LUMP			
0290	502.235 STRUCTURAL CONCRETE, PIER PILE CAP & EDGE BEAM	140.000 CY				
0300	502.411 STRUCTURAL CONCRETE, PIER DECK SLAB	145.000 CY				
0310	502.45 STRUCTURAL CONCRETE APPROACH SLABS PIER APPROACH	65.000 CY				
0320	502.491 STRUCTURAL CONCRETE, PIER CURB	5.000 CY				

SCHEDULE OF ITEMS

REVISED:

CONTRACT ID: 017820.00

PROJECT(S): DTMA1G10006 / TIGER+S

CONTRACTOR : _____

LINE NO	ITEM DESCRIPTION	APPROX. QUANTITY AND UNITS	UNIT PRICE		BID AMOUNT	
			DOLLARS	CTS	DOLLARS	CTS
0330	502.601 STRUCTURAL CONCRETE, TRANSFORMER FOUNDATION	LUMP	LUMP			
0340	502.602 STRUCTURAL CONCRETE, GENERATOR SLAB	LUMP	LUMP			
0350	502.603 STRUCTURAL CONCRETE, CONDENSER PAD	LUMP	LUMP			
0360	502.604 STRUCTURAL CONCRETE, MAINTENANCE BLD. SLAB	LUMP	LUMP			
0370	503.14 EPOXY-COATED REINFORCING STEEL, FABRICATED AND DELIVERED	72000.000 LB				
0380	503.15 EPOXY-COATED REINFORCING STEEL, PLACING	72000.000 LB				
0390	504.810 STRUCTURAL STEEL ERECTION FOR MODIFICATIONS	LUMP	LUMP			
0400	504.8210 STEEL REEFER UNIT FRAMES & INSTALLATION	LUMP	LUMP			
0410	506.9106 FUSION BONDED EPOXY COATING	LUMP	LUMP			
0420	514.06 CURING BOX FOR CONCRETE CYLINDERS	1.000 EA				

SCHEDULE OF ITEMS

REVISED:

CONTRACT ID: 017820.00

PROJECT(S): DTMA1G10006 / TIGER+S

CONTRACTOR : _____

LINE NO	ITEM DESCRIPTION	APPROX. QUANTITY AND UNITS	UNIT PRICE		BID AMOUNT	
			DOLLARS	CTS	DOLLARS	CTS
0430	515.20 PROTECTIVE COATING FOR CONCRETE SURFACES	780.000 SY				
0440	520.240 EXPANSION DEVICE - PIER COMPRESSION SEAL	50.000 LF				
0450	526.301 TEMPORARY CONCRETE BARRIER TYPE I	LUMP	LUMP			
0460	528.08 STRUCTURAL TIMBER	LUMP	LUMP			
0470	535.631 PRESTRESSED STRUCTURAL CONCRETE DECK PLANKS	LUMP	LUMP			
0480	603.157 12 INCH PVC PIPE	935.000 LF				
0490	603.167 15 INCH POLYVINYLCHLORIDE (PVC) PIPE	285.000 LF				
0500	604.097 72 INCH CATCH BASIN TYPE B1-C	1.000 EA				
0510	604.11 CATCH BASIN TYPE C1	20.000 EA				
0520	604.15 MANHOLE	2.000 EA				
0530	604.154 72 INCH MANHOLE	1.000 EA				

SCHEDULE OF ITEMS

REVISED:

CONTRACT ID: 017820.00

PROJECT(S): DTMA1G10006 / TIGER+S

CONTRACTOR : _____

LINE NO	ITEM DESCRIPTION	APPROX. QUANTITY AND UNITS	UNIT PRICE		BID AMOUNT	
			DOLLARS	CTS	DOLLARS	CTS
0540	604.16 ALTERING CATCH BASIN TO MANHOLES	2.000 EA				
0550	604.161 ALTERING CATCH BASIN	6.000 EA				
0560	604.18 ADJUSTING MANHOLE OR CATCH BASIN TO GRADE	8.000 EA				
0570	604.247 CATCH BASIN TYPE F5-C	1.000 EA				
0580	607.1601 TEMPORARY CHAIN LINK FENCE - 4'	400.000 LF				
0590	607.1701 TEMPORARY CHAIN LINK FENCE - 6' MOVEABLE	1680.000 LF				
0600	607.2301 TEMPORARY CHAIN LINK GATE	1.000 EA				
0610	607.25 REMOVE AND RESET CHAIN LINK FENCE	870.000 LF				
0620	607.2501 REMOVE CHAIN LINK FENCE	110.000 LF				
0630	607.490 CHAIN LINK GATE - 16 FT. SWING	1.000 EA				
0640	607.4911 MOTORIZED SLIDE GATE - 24 FT.	1.000 EA				

SCHEDULE OF ITEMS

REVISED:

CONTRACT ID: 017820.00

PROJECT(S): DTMA1G10006 / TIGER+S

CONTRACTOR : _____

LINE NO	ITEM DESCRIPTION	APPROX. QUANTITY AND UNITS	UNIT PRICE		BID AMOUNT	
			DOLLARS	CTS	DOLLARS	CTS
0650	607.4921 REMOVE GATE & MOTORS	4.000 EA				
0660	607.493 REMOVE & RESET MOTORIZED SLIDING GATE - 14 FT.	1.000 EA				
0670	607.501 SPECIAL REMOVABLE GATE POST	LUMP	LUMP			
0680	607.502 SPECIAL SECURITY GATE POST	LUMP	LUMP			
0690	608.081 REINFORCED CONCRETE DRIVEWAYS WALKWAYS	110.000 SY				
0700	609.11 VERTICAL CURB TYPE 1	140.000 LF				
0710	609.12 VERTICAL CURB TYPE 1 - CIRCULAR	105.000 LF				
0720	609.234 TERMINAL CURB TYPE 1 - 4 FOOT	2.000 EA				
0730	609.237 TERMINAL CURB TYPE 1 - 7 FOOT	1.000 EA				
0740	609.2371 TERMINAL CURB TYPE 1- 7 FT - CIRCULAR	2.000 EA				
0750	609.30 PRECAST CONCRETE CURB FOR PIERS	50.000 LF				

SCHEDULE OF ITEMS

REVISED:

CONTRACT ID: 017820.00

PROJECT(S): DTMA1G10006 / TIGER+S

CONTRACTOR : _____

LINE NO	ITEM DESCRIPTION	APPROX. QUANTITY AND UNITS	UNIT PRICE		BID AMOUNT	
			DOLLARS	CTS	DOLLARS	CTS
0760	609.31 CURB TYPE 3	130.000 LF				
0770	615.07 LOAM	80.000 CY				
0780	618.1301 SEEDING METHOD NUMBER 1 - PLAN QUANTITY	6.000 UN				
0790	619.1201 MULCH - PLAN QUANTITY	6.000 UN				
0800	621.126 SMALL DECIDUOUS TREES (6 FOOT - 8 FOOT) GROUP A	2.000 EA				
0810	621.5352 DECIDUOUS SHRUBS (18 INCH - 24 INCH) GROUP A	10.000 EA				
0820	621.80 ESTABLISHMENT PERIOD	LUMP	LUMP			
0830	621.901 LANDSCAPE BORDER & FOUNDATION FOR OFFICE BLD. EXTERIOR SIGN	LUMP	LUMP			
0840	621.951 BIKE RACK	LUMP	LUMP			
0850	627.901 PAVEMENT MARKINGS IN OFFICE PARKING LOT & DRIVEWAYS	LUMP	LUMP			
0860	639.18 FIELD OFFICE TYPE A	1.000 EA				

SCHEDULE OF ITEMS

REVISED:

CONTRACT ID: 017820.00

PROJECT(S): DTMA1G10006 / TIGER+S

CONTRACTOR : _____

LINE NO	ITEM DESCRIPTION	APPROX. QUANTITY AND UNITS	UNIT PRICE		BID AMOUNT	
			DOLLARS	CTS	DOLLARS	CTS
0870	652.35 CONSTRUCTION SIGNS	150.000 SF				
0880	656.75 TEMPORARY SOIL EROSION AND WATER POLLUTION CONTROL	LUMP	LUMP			
0890	659.10 MOBILIZATION	LUMP	LUMP			
0900	801.15 6 INCH PVC SANITARY SEWER (SCHEDULE 40)	535.000 LF				
0910	803.173 SEWER MANHOLE - 4 FOOT DIAMETER	3.000 EA				
0920	810.4002 OFFICE BUILDING - VISITOR ENTRANCE SIGN	LUMP	LUMP			
0930	810.4003 OFFICE BUILDING - STOP SIGN	LUMP	LUMP			
0940	815.00 BUILDING ARCHITECTURAL	LUMP	LUMP			
0950	815.00 BUILDING ELECTRICAL	LUMP	LUMP			
0960	815.00 BUILDING MECHANICAL	LUMP	LUMP			
0970	815.00 BUILDING STRUCTURAL	LUMP	LUMP			

SCHEDULE OF ITEMS

REVISED:

CONTRACT ID: 017820.00

PROJECT(S): DTMA1G10006 / TIGER+S

CONTRACTOR : _____

LINE NO	ITEM DESCRIPTION	APPROX. QUANTITY AND UNITS	UNIT PRICE		BID AMOUNT	
			DOLLARS	CTS	DOLLARS	CTS
0980	822.320 6" PVC WATERMAIN	240.000 LF				
0990	822.3212 4" PVC WATERMAIN	330.000 LF				
1000	823.3253 TAPPING SLEEVE & GATE VALVE WITH BOX	6.000 EA				
1010	823.33 6 INCH GATE VALVE WITH BOX	4.000 EA				
1020	823.335 4 INCH GATE VALVE W/ SERVICE BOX	3.000 EA				
1030	824.32 REMOVE/RESET HYDRANT	2.000 EA				
1040	827.37 NATURAL GAS DISTRIBUTION	LUMP	LUMP			
1050	832.071 CONTRACTOR ALLOWANCE BUILDING PERMIT, FEES & INSPECT.	LUMP	LUMP		5000	.00
1060	832.071 CONTRACTOR ALLOWANCE CMP	LUMP	LUMP		4000	.00
1070	832.071 CONTRACTOR ALLOWANCE FAIRPOINT	LUMP	LUMP		500	.00
1080	832.071 CONTRACTOR ALLOWANCE PWD	LUMP	LUMP		500	.00

SCHEDULE OF ITEMS

REVISED:

CONTRACT ID: 017820.00

PROJECT(S): DTMA1G10006 / TIGER+S

CONTRACTOR : _____

LINE NO	ITEM DESCRIPTION	APPROX. QUANTITY AND UNITS	UNIT PRICE		BID AMOUNT	
			DOLLARS	CTS	DOLLARS	CTS
1090	832.071 CONTRACTOR ALLOWANCE UNITIL	LUMP	LUMP		500	.00
1100	910.42 ELECTRICAL - PIER FACILITY SITE - ELECTRICAL	LUMP	LUMP			
	SECTION 0001 TOTAL					.

SECTION 0002 BID ALT. 1

1110	890.011 PIER 12 FT. SECTION ADDITION	EA	1.000			
	SECTION 0002 TOTAL					.

SECTION 0003 BID ALT. 2

1120	528.601 STRUCTURAL TIMBER DECKING ADDITIONAL	LUMP	LUMP			
	SECTION 0003 TOTAL					.

SECTION 0004 BID ALT. 3

1130	627.902 PAVEMENT MARKINGS IN CONTAINER STORAGE LOT	LUMP	LUMP			
------	--	------	------	--	--	--

SCHEDULE OF ITEMS

REVISED:

CONTRACT ID: 017820.00

PROJECT(S): DTMA1G10006 / TIGER+S

CONTRACTOR : _____

LINE NO	ITEM DESCRIPTION	APPROX. QUANTITY AND UNITS	UNIT PRICE		BID AMOUNT	
			DOLLARS	CTS	DOLLARS	CTS
1140	627.903 PAVEMENT MARKINGS ON EXISTING CONCRETE PIER	LUMP	LUMP			
	SECTION 0004 TOTAL					.

SECTION 0005 BID ALT. 4

1150	655.501 CATHODIC PROTECTION BY SACRIFICIAL ANODE	EA	18.000			
	SECTION 0005 TOTAL					.

SECTION 0006 BID ALT. 5

1160	841.50 RESET LARGE STEEL BOLLARD	LUMP	LUMP			
	SECTION 0006 TOTAL					.

SECTION 0007 BID ALT. 6

1170	810.4001 OFFICE BUILDING - EXTERIOR BUILDING SIGN	LUMP	LUMP			
	SECTION 0007 TOTAL					
	TOTAL BID					

June 29, 2011

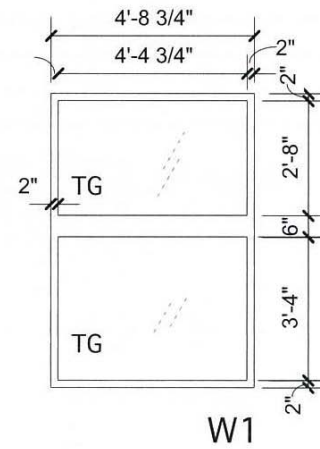
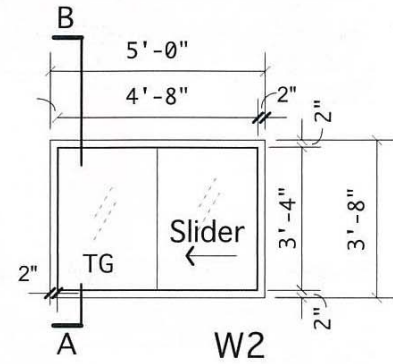
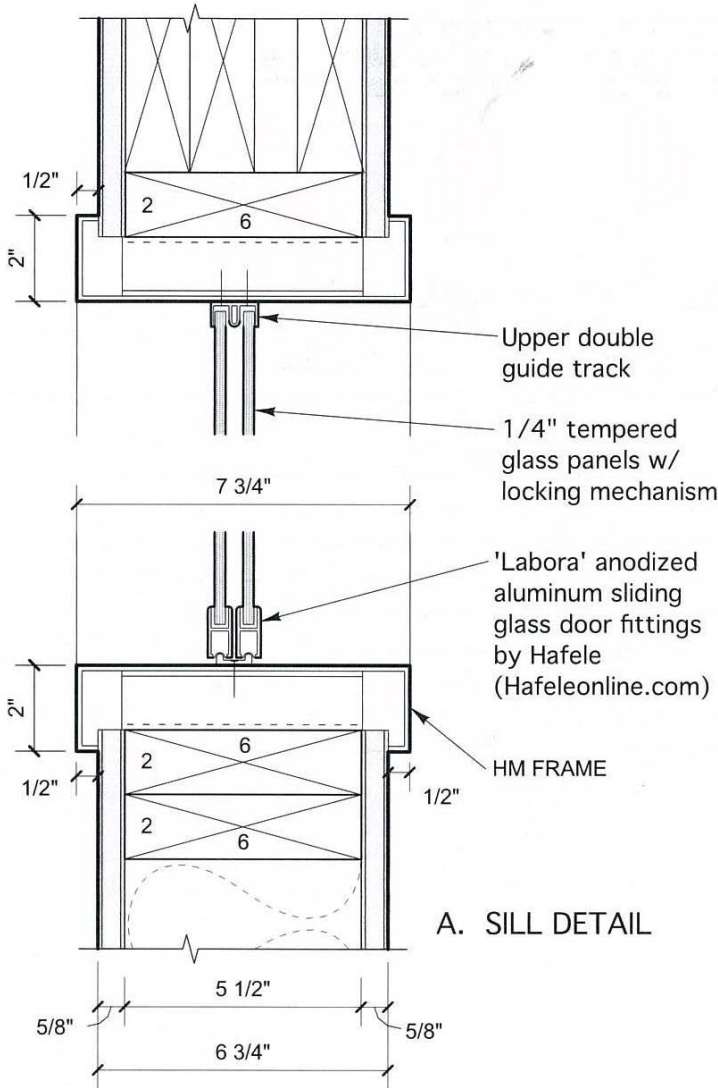

INTERIOR WINDOWS

1/4" = 1'-0"

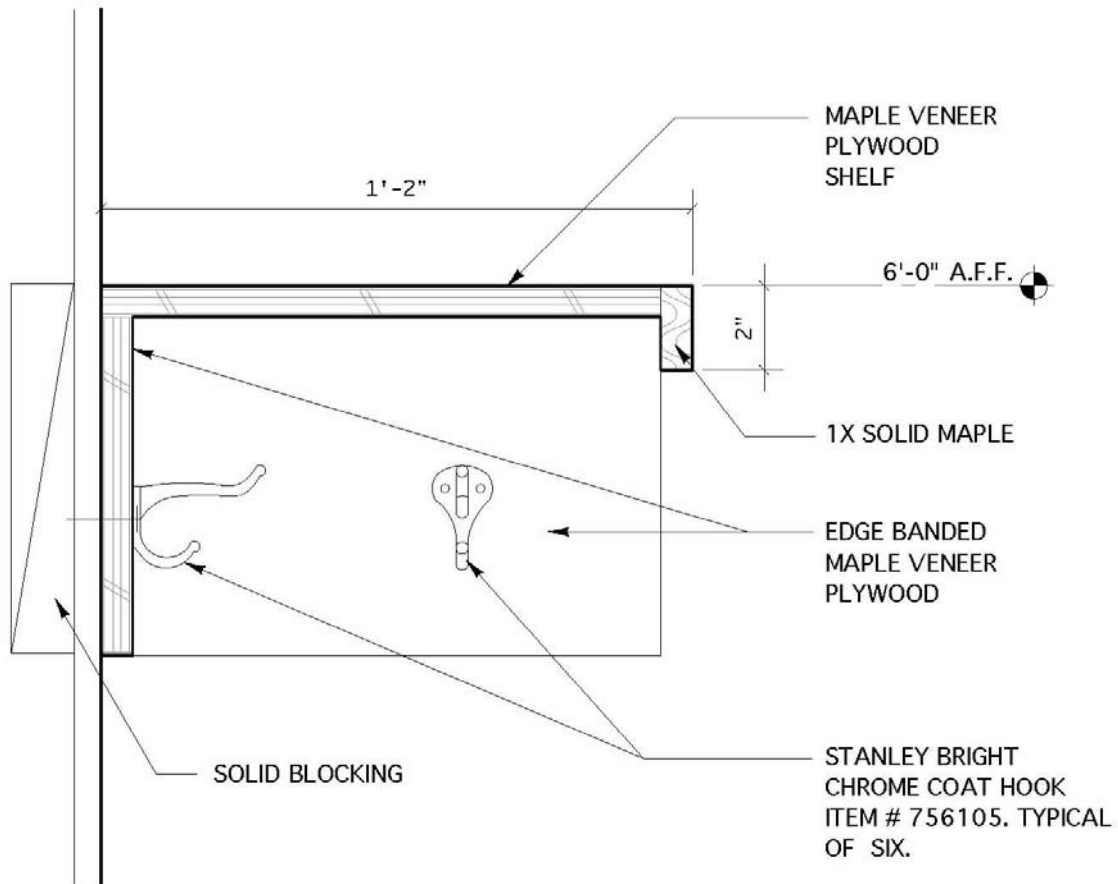

SHELF AND HOOK DETAIL AT ENTRY 107

3" = 1'-0"