

CONTRACT DOCUMENTS
FOR
EARLEYS BRIDGE SUBSTRUCTURE REPLACEMENT
IN THE TOWN OF:
WILLIMANTIC, MAINE
Maine DOT PIN 017090.00



June 4TH 2010

PREPARED BY:

CALDERWOOD ENGINEERING, ETC.

SET NUMBER _____

TABLE OF CONTENTES

Table of Contents.....i

Notice to Contractors.....1

Acknowledgement of Amendments.....2

Schedule of Bid Prices.....3-4

Contract Agreement, Offer & Award.....5-8

Contract Bonds.....9-10

Location Map.....11

Special Provisions.....12-21

Environmental Permits.....22-65

TOWN OF WILLIMANTIC, MAINE NOTICE TO CONTRACTORS

Sealed Bids addressed to the Town of Willimantic, Maine 04443 and endorsed on the wrapper "Bids for Earleys Bridge Substructure Replacement in the town of **WILLIMANTIC**" will be received from contractors at the Town of Willimantic Town Hall, Willimantic, Maine, until 6:30 o'clock P.M. (prevailing time) on Thursday, July 15th 2010, and at that time and place publicly opened and read. Bids will be accepted from contractors prequalified by the Department of Transportation for BRIDGE projects. All other Bids may be rejected. **We now accept electronic bids for those bid packages posted on the bidx.com website. Electronic bids do not have to be accompanied by paper bids. Please note: the Department will accept a facsimile of the bid bond; however, the original bid bond must then be received at the MDOT Contract Section within 72 hours of the bid opening.** Until further notice, dual bids (one paper, one electronic) will be accepted, with the paper copy taking precedence.

Description: MaineDOT PIN(017090.00)

Location: In Piscataquis County, project is located over Wilson Stream in the town of Willimantic, Maine, off Rt. 150.

Outline of Work: The work to be done under this contract consists of jacking up of the existing bridge superstructure, partial removal of the steel superstructure, removal of existing wooden cribbed abutments, construction of new cast-in-place concrete, steel reinforced abutments, installation of new bridge bearings, matching roadway work and other incidental work.

For general information regarding Bidding and Contracting procedures, contact Eric Calderwood at (207)737-2007. For Project-specific information fax all questions to **Eric Calderwood** at (207)737-2008. Questions received after 12:00 noon of Monday prior to bid date will not be answered. Bidders shall not contact any other Departmental staff for clarification of Contract provisions, and the Department will not be responsible for any interpretations so obtained.

Plans, specifications and bid forms may be obtained electronically for free or hard copy upon the payment of \$150.00 for each set, non-refundable, by contacting Eric Calderwood at Calderwood Engineering, etc., 222 River Rd. Richmond, Maine 04357. PH: (207)737-2007; FAX(207)737-2008; e-mail eric@calderwoodengineering.com. In addition there will be a non-refundable \$10.00 mailing charge if mailed.

Each Bid must be made upon blank forms provided by the Town of Willimantic and must be accompanied by a bid bond at 5% of the bid amount payable to Treasurer, Town of Willimantic as a Bid guarantee. A Contract Performance Surety Bond and a Contract Payment Surety Bond, each in the amount of 100 percent of the Contract price, will be required of the successful Bidder. Bids should be sent to **Town of Willimantic, PO Box 152, Willimantic, ME 04443**.

This Contract is subject to all applicable Federal Laws. This contract is subject to compliance with the Disadvantaged Business Enterprise program requirements as set forth by the Maine Department of Transportation.

All work shall be governed by "State of Maine, Department of Transportation, Standard Specifications, Revision of December 2002", price \$10 [\$13 by mail], and Standard Details, Revision of December 2002, price \$20 [\$25 by mail]. Standard Detail updates can be found at <http://www.state.me.us/mdot/project/design/homepg.htm>.

"State of Maine Department of Transportation, Standard Specifications, Revision of December 2002" and Standard Details may be found in their entirety online at

http://www.maine.gov/mdot/contractor-consultant-information/ss_standard_specification_2002.php and

http://www.maine.gov/mdot/contractor-consultant-information/ss_standard_details_updates.php respectively.

The right is hereby reserved to the Town of Willimantic to accept or reject any or all bids.

Richmond, Maine
May 24th, 2010

ERIC T. CALDERWOOD

CHIEF ENGINEER

**SPECIAL PROVISION 102.7.3
ACKNOWLEDGMENT OF BID AMENDMENTS**

With this form, the Bidder acknowledges its responsibility to check for all Amendments to the Bid Package. For the Project under Advertisement, Amendments are located at Calderwood Engineering, etc. 222 River Road, Richmond, ME 04357. PH: (207)737-2007; FAX: (207)737-2008; e-mail Eric@Calderwoodengineering.com. It is the responsibility of the Bidder to determine if there are Amendments to the Project, to obtain them, to incorporate them into their Bid Package, and to reference the Amendment number and the date on the form below. Calderwood Engineering will not post Bid Amendments any later than noon the day before Bid opening without individually notifying all the planholders.

Amendment Number	Date

The Contractor, for itself, its successors and assigns, hereby acknowledges that it has received all of the above referenced Amendments to the Bid Package.

CONTRACTOR

Date

Signature of authorized representative

(Name and Title Printed)

**SCHEDULE OF BID PRICES
CONTRACT NO. 017090.00
EALEYS BRIDGE SUBSTRUCTURE REPLACEMENT
TOWN OF WILLIMANTIC, MAINE**

ITEM #	DESCRIPTION	APPROXIMATE QUANTATIES	UNIT	UNIT PRICE		BID PRICE AMOUNT	
				DOLLARS	CENTS	DOLLARS	CENTS
202.10	PARTIAL REMOVAL OF SUPERSTRUCTURE (SEE PLANS)	1	LS				
203.20	COMMON EXCAVATION	80	CY				
203.24	COMMON BORROW	260	CY				
203.25	GRANULAR BORROW	490	CY				
206.082	STRUCTURAL EARTH EXC. - MAJOR STRUCTURES	740	CY				
304.10	AGGR SUBB COURSE - GRAVEL	130	CY				
502.21	STRUCTURAL CONCRETE ABUT & RET WALL	225	CY				
502.56	CONCRETE FILL	35	CY				
503.12	REINFORCING STEEL, FAB & DEL	11200	LB				
503.13	REINFORCING STEEL, PLACING	11200	LB				
511.07	COFFERDAM - ABUTMENT #1	1	EA				
511.07	COFFERDAM - ABUTMENT #2	1	EA				
526.30	TEMPORARY CONCRETE BARRIER TYPE I	40	LF				

ITEM #	DESCRIPTION	APPROXIMATE QUANTATIES	UNIT	UNIT PRICE		BID PRICE AMOUNT	
				DOLLARS	CENTS	DOLLARS	CENTS
606.23	GUARDRAIL TYPE 3C - SINGLE RAIL	75	LF				
606.78	LOW VOLUME GUARDRAIL END	4	EA				
610.08	PLAIN RIP RAP	140	CY				
615.07	LOAM	25	CY				
618.1401	SEEDING METHOD #2, PLAN QUANTITY	4	UNITS				
619.1201	MULCH, PLAN QUANTITY	4	UNITS				
652.312	TYPE III BARRICADES	4	EA				
656.75	TEMP. SOIL EROSION AND WATER POLL. CONTROL	1	LS				
659.10	MOBILIZATION	1	LS				
					TOTAL BID:		

CONTRACT AGREEMENT, OFFER & AWARD

AGREEMENT made on the date last signed below, by and between the Town of WILLIMANTIC, acting through and by its Town Selectman,

_____ a corporation or other legal entity organized under the laws of the State of _____, with its principal place of business located at _____

The Department and the Contractor, in consideration of the mutual promises set forth in this Agreement (the “Contract”), hereby agree as follows:

A. The Work.

The Contractor agrees to complete all Work as specified or indicated in the Contract including Extra Work in conformity with the Contract, PIN No. **017090.00**, for the **REPLACEMENT OF EARLEYS BRIDGE SUBSTRUCTURE #2995** in the town of **Willimantic**, County of **Piscataquis**, Maine. The Work includes construction, maintenance during construction, warranty as provided in the Contract, and other incidental work.

The Contractor shall be responsible for furnishing all supervision, labor, equipment, tools supplies, permanent materials and temporary materials required to perform the Work including construction quality control including inspection, testing and documentation, all required documentation at the conclusion of the project, warranting its work and performing all other work indicated in the Contract.

The Department shall have the right to alter the nature and extent of the Work as provided in the Contract; payment to be made as provided in the same.

B. Time.

The Contractor agrees to complete all Work, except warranty work, on or before **October 15th, 2011**. Further, the Department may deduct from moneys otherwise due the Contractor, not as a penalty, but as Liquidated Damages in accordance with Sections 107.7 and 107.8 of the State of Maine Department of Transportation Standard Specifications, Revision of December 2002.

C. Price.

The quantities given in the Schedule of Items of the Bid Package will be used as the basis for determining the original Contract amount and for determining the amounts of the required Performance Surety Bond and Payment Surety Bond, and that the amount of this offer is _____

\$_____ Performance Bond and Payment Bond each being 100% of the amount of this Contract.

D. Contract.

This Contract, which may be amended, modified, or supplemented in writing only, consists of the Contract documents as defined in the Plans, Standard Specifications, Revision of December 2002, Standard Details Revision of December 2002 as updated through advertisement, Supplemental Specifications, Special Provisions, Contract Agreement; and Contract Bonds. It is agreed and understood that this Contract will be governed by the documents listed above.

E. Certifications.

By signing below, the Contractor hereby certifies that to the best of the Contractor's knowledge and belief:

1. All of the statements, representations, covenants, and/or certifications required or set forth in the Bid and the Bid Documents, including those in Appendix A to Division 100 of the Standard Specifications Revision of December 2002 (Federal Contract Provisions Supplement), and the Contract are still complete and accurate as of the date of this Agreement.
2. The Contractor knows of no legal, contractual, or financial impediment to entering into this Contract.
3. The person signing below is legally authorized by the Contractor to sign this Contract on behalf of the Contractor and to legally bind the Contractor to the terms of the Contract.

F. Offer.

The undersigned, having carefully examined the site of work, the Plans, Standard Specifications Revision of December 2002, Standard Details Revision of December 2002 as updated through advertisement, Supplemental Specifications, Special Provisions, Contract Agreement; and Contract Bonds contained herein for construction of: **Earleys Bridge Substructure Replacement in Willimantic,**

State of Maine, on which bids will be received until the time specified in the "Notice to Contractors" do(es) hereby bid and offer to enter into this contract to supply all the materials, tools, equipment and labor to construct the whole of the Work in strict accordance with the terms and conditions of this Contract at the unit prices in the attached "Schedule of Items".

The Offeror agrees to perform the work required at the price specified above and in accordance with the bids provided in the attached "Schedule of Items" in strict accordance with the terms of this solicitation, and to provide the appropriate insurance and bonds if this offer is accepted by the Government in writing.

As Offeror also agrees:

First: To do any extra work, not covered by the attached "Schedule of Items", which may be ordered by the Resident, and to accept as full compensation the amount determined upon a "Force Account" basis as provided in the Standard Specifications, Revision of December 2002, and as addressed in the contract documents.

Second: That the bid bond at 5% of the bid amount or the official bank check, cashier's check, certificate of deposit or U. S. Postal Money Order in the amount given in the "Notice to Contractors", payable to the Treasurer of the Town of Willimantic and accompanying this bid, shall be forfeited, as liquidated damages, if in case this bid is accepted, and the undersigned shall fail to abide by the terms and conditions of the offer and fail to furnish satisfactory insurance and Contract bonds under the conditions stipulated in the Specifications within 15 days of notice of intent to award the contract.

Third: To begin the Work on the date specified in the Engineer's "Notice to Commence Work" as stated in Section 107.2 of the Standard Specifications Revision of December 2002 and complete the Work within the time limits given in the Special Provisions of this Contract.

Fourth: The Contractor will be bound to the Disadvantaged Business Enterprise (DBE) Requirements contained in the attached Notice (Additional Instructions to Bidders) and submit a completed Contractor's Disadvantaged Business Enterprise Utilization Plan by 4:30pm on the day of bid opening to the Contracts Engineer.

Fifth: That this offer shall remain open for 30 calendar days after the date of opening of bids.

Sixth: The Bidder hereby certifies, to the best of its knowledge and belief that: the Bidder has not, either directly or indirectly, entered into any agreement, participated in any collusion, or otherwise taken any action in restraint of competitive bidding in connection with its bid, and its subsequent contract with the Department.

IN WITNESS WHEREOF, the Contractor, for itself, its successors and assigns, hereby execute two duplicate originals of this Agreement and thereby binds itself to all covenants, terms, and obligations contained in the Contract Documents.

CONTRACTOR

Date

(Signature of Legally Authorized Representative
of the Contractor)

Witness

(Name and Title Printed)

G. Award.

Your offer is hereby accepted.
documents referenced herein.

This award consummates the Contract, and the

TOWN OF WILLIMANTIC

Date

By: John M. Tatko III, Chair of Selectmen

Witness

BOND # _____

CONTRACT PERFORMANCE BOND
(Surety Company Form)

KNOW ALL MEN BY THESE PRESENTS: That _____
_____ **and the State of** _____, as principal,
and.....
a corporation duly organized under the laws of the State of and having a
usual place of business
as Surety, are held and firmly bound unto the Treasurer of the Town of Willimantic in
the sum of _____ **and 00/100 Dollars (\$**
) , to be paid said Treasurer of the Town of Willimantic or his successors in office, for
which payment well and truly to be made, Principal and Surety bind themselves, their
heirs, executors and administrators, successors and assigns, jointly and severally by these
presents.

The condition of this obligation is such that if the Principal designated as Contractor in
the Contract to construct Project Number 017090.00 in the Municipality of Willimantic
promptly and faithfully performs the Contract, then this obligation shall be null and void;
otherwise it shall remain in full force and effect.

The Surety hereby waives notice of any alteration or extension of time made by the Town
of Willimantic.

Signed and sealed this day of, 20.....

WITNESSES:

SIGNATURES:

CONTRACTOR:

Signature.....

.....

Print Name Legibly

Print Name Legibly

SURETY:

Signature

.....

Print Name Legibly

Print Name Legibly

SURETY ADDRESS:

NAME OF LOCAL AGENCY:

ADDRESS

.....
.....
.....

.....
.....
.....

TELEPHONE.....

.....

BOND # _____

CONTRACT PERFORMANCE BOND
(Surety Company Form)

KNOW ALL MEN BY THESE PRESENTS: That _____
_____ **and the State of** _____, as principal,
and.....
a corporation duly organized under the laws of the State of and having a
usual place of business
as Surety, are held and firmly bound unto the Treasurer of the Town of Willimantic in
the sum of _____ **and 00/100 Dollars (\$**
) , to be paid said Treasurer of the Town of Willimantic or his successors in office, for
which payment well and truly to be made, Principal and Surety bind themselves, their
heirs, executors and administrators, successors and assigns, jointly and severally by these
presents.

The condition of this obligation is such that if the Principal designated as Contractor in
the Contract to construct Project Number 017090.00 in the Municipality of Willimantic
promptly and faithfully performs the Contract, then this obligation shall be null and void;
otherwise it shall remain in full force and effect.

The Surety hereby waives notice of any alteration or extension of time made by the Town
of Willimantic.

Signed and sealed this day of, 20.....

WITNESSES:

SIGNATURES:

CONTRACTOR:

Signature.....

.....

Print Name Legibly

Print Name Legibly

SURETY:

Signature

.....

Print Name Legibly

Print Name Legibly

SURETY ADDRESS:

NAME OF LOCAL AGENCY:

ADDRESS

.....

.....

.....

.....

TELEPHONE.....

.....

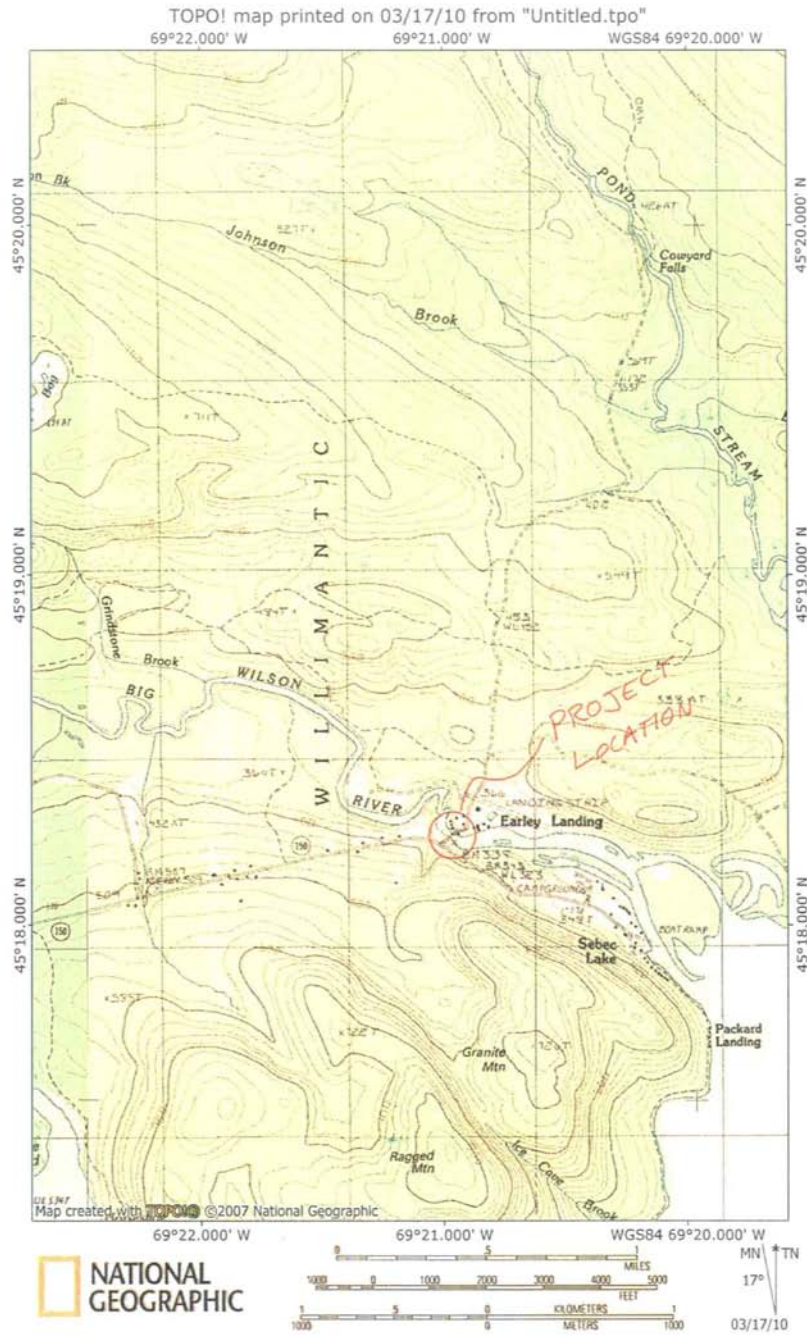

SPECIAL PROVISION
SECTION 101
DEFINITIONS

The standard specification is amended as follows:

Add the following to section 101.2 Definitions

REPLACE: “The Department of Transportation of the State of Maine, as established by 23 MRSA §4202 et seq. for the administration of Highway, Bridge, and other public Works; acting through the Commissioner and his/her duly authorized representatives. For related provisions, see definitions of Project Manager, and Resident.

WITH: “The Town of Willimantic in conjunction with Calderwood Engineering, etc.”

SPECIAL PROVISION
SECTION 105
GENERAL SCOPE OF WORK
(Environmental Requirements)

In-Water work consists of any activity conducted below the normal high water mark of a river, stream, brook, lake, pond or “Coastal Wetland” areas that are subject to tidal action during the highest tide level for the year which an activity is proposed as identified in the tide tables published by the National Ocean Service. <http://www.oceanservice.noaa.gov/>
For the full definition of “Coastal Wetlands”, please refer to 38 MRSA 480-B(2)

I. In-Water Work is allowed between May 1st and August 14th.

II. In-Water work window applies to the following water bodies:

1. Wilson Stream

III. Special Conditions:

1. Must adhere to ACOE and DEP permits.

IV. Approvals:

1. Temporary Soil Erosion and Water Pollution Control Plan

V. All activities are prohibited (including placement and removal of cofferdams unless otherwise permitted by Regulatory Agencies) below the normal high water mark if outside the prescribed in-water work window, except for the following:

1. Work within a cofferdam constructed according to MaineDOT’s Standard Specifications and in adherence with the contractors approved “Soil Erosion and Water Pollution Control Plan”.

VI. No work is allowed that completely blocks a river, stream, or brook without providing downstream flow.

NOTE: Regulatory Review and Approval is required to modify the existing In-Water work window.

SPECIAL PROVISION
SECTION 107
TIME

The Bridge is to be closed to traffic during construction of the new abutments, once the project begins and the bridge is closed to traffic the contractor shall continue the work with only normal stoppages for weather, daylight, and weekends until the bridge is open to traffic again. The maximum period of closure of the bridge shall be 90 days.

A minimum of 10 days Prior to closing the bridge to traffic the contractor shall post signs at each end of the bridge indicating the anticipated closure date and duration. This provision is in addition to the requirements of standard specification section 104.4.10 Coordination of Bridge Closure/Bridge Width Restriction Notification.

Add the following to section 107.1 Contract Time and Contract Completions Date

If construction is to begin in 2010 and be completed in 2011 no further permits would be required, although all in stream work and materials shall be removed on or before August 14th 2010. If construction is to begin in 2011, new Army Corps permits shall be obtained by Calderwood Engineering, etc. No changes to project plans or specifications are anticipated from obtaining a new permit.

SPECIAL PROVISION
SECTION 107
PROSECUTION & PROGRESS

The Specified Contract Completion date is October 15th, 2011

SPECIAL PROVISION
SECTION 110
INDEMNIFICATION, BONDING AND INSURANCE

The standard specification is amended as follows:

Add the following to section 110.2.1 Bonds.

REPLACE: “The bonds shall each be in the full Contract amount, payable to the
“Treasurer - State of Maine”

WITH: “The bonds shall each be in the full Contract amount, payable to the “Treasurer –
Town of Willimantic”.

SPECIAL PROVISION
SECTION 202
REMOVING STRUCTURES AND OBSTRUCTIONS

The standard specification is amended as follows:

202.01 Description: The following sentence is added to the end of this paragraph:

This work shall also consist of jacking of the existing superstructure girders deck and railing in a manner that will prevent damage to the Existing structure to remain and will allow for the removal of the existing abutments and construction of the new abutments, and removal of approximately 4' of the length of the existing bridge superstructure, decking, and railings from the abutment #1 end of the structure.

SPECIAL PROVISION
SECTION 502
STRUCTURAL CONCRETE
(QC/QA Acceptance Methods)

All concrete is class A concrete with a P value = \$500.00 and will be performed using method C

SPECIAL PROVISION
SECTION 511
COFFERDAMS

The standard specification is amended as follows:

Add the following paragraph to section 511.03

If the contractor decides to carry the project from 2010 into 2011, any cofferdam in place must be removed before or on August 14th 2010 and must remain out of the Stream until May 1st 2011.

SPECIAL PROVISION
SECTION 523
STEEL BEARINGS

The standard specification is amended as follows:

Add the following paragraph to section 523.10 Steel Bearings:

The proposed bearings require that a hole be placed in the flange of the existing steel girders. The new bearings include the installation of anchor rods, neoprene bearing pads and steel plates, as indicated on the plans. The new steel plates and anchor rods shall be hot dip galvanized. The neoprene bearing pad shall be polychloroprene or natural polyisoprene with a 55-65 shore A durometer hardness.

Add the following to section 523.51 Basis of Payment

REPLACE: “Bearings will be paid for at the contract unit price each, which price shall be full compensation for the design, fabrication, testing, and delivery. Bearing installation will be paid for at the contract unit price each which price shall be full compensation for installation, including all materials, equipment, labor and incidentals necessary for installing the bearings in accordance with the plans and this Specification. Removal of the existing bearings if present, including all materials, equipment, labor and incidentals necessary for jacking the superstructure, removal of the existing bearings and preparation of the bridge seat in accordance with the plans and this Specification shall be considered incidental to bearing installation.”

WITH: “Payment for materials, installation of new bearings, removal of old bearings, preparation of the bridge seat in accordance with the plans and this Specification, labor and incidentals necessary for jacking the superstructure shall be considered incidental to other work.”

SPECIAL PROVISION
SECTION 524
TEMPORARY STRUCTURAL SUPPORTS

The standard specification is amended as follows:

Add the following paragraph to section 524.01 Description:

The existing superstructure is to be jacked up in place and temporarily supported during the removal of the existing substructure and the partial removal of the superstructure, as indicated on the plans. The estimated temporary jack reactions indicated on the plans coincide with the jacking locations shown. Any alterations of the jacking locations will result in differing jacking reactions and shall be anticipated and adjusted accordingly.

Add the following paragraph to section 524.29 Basis of Payment:

REPLACE: “Temporary structural supports will be paid for at the contract unit price each which price shall be full compensation for all materials, equipment, labor and incidentals necessary for the design, erection, maintenance, and dismantling of such supports in accordance with these specifications.”

WITH: “Payment for temporary structural supports will be considered incidental to other work”



**US Army Corps
of Engineers**
New England District

(Minimum Notice: Permittee must sign and return notification
within one month of the completion of work.)

COMPLIANCE CERTIFICATION FORM

USACE Project Number: NAE-2010-00534

Name of Permittee: Town of Willimantic

Permit Issuance Date: _____

Please sign this certification and return it to the following address upon completion of the activity and any mitigation required by the permit. You must submit this after the mitigation is complete, but not the mitigation monitoring, which requires separate submittals.

* MAIL TO: U.S. Army Corps of Engineers, New England District *
* Policy Analysis/Technical Support Branch *
* Regulatory Division *
* 696 Virginia Road *
* Concord, Massachusetts 01742-2751 *

Please note that your permitted activity is subject to a compliance inspection by an U.S. Army Corps of Engineers representative. If you fail to comply with this permit you are subject to permit suspension, modification, or revocation.

I hereby certify that the work authorized by the above referenced permit was completed in accordance with the terms and conditions of the above referenced permit, and any required mitigation was completed in accordance with the permit conditions.

Signature of Permittee

Date

Printed Name

Date of Work Completion

() _____

() _____

Telephone Number

Telephone Number



DEPARTMENT OF THE ARMY
NEW ENGLAND DISTRICT, CORPS OF ENGINEERS
596 VIRGINIA ROAD
CONCORD, MASSACHUSETTS 01742 2751

REPLY TO:
ATTENTION OF:

MAINE PROGRAMMATIC GENERAL PERMIT (PGP)
AUTHORIZATION LETTER AND SCREENING SUMMARY

TOWN OF WILLIMANTIC
P.O. BOX 152
WILLIMANTIC, MAINE 04443

CORPS PERMIT # NAE-2010-00534
CORPS PGP ID# 10-085
STATE ID# PBR

DESCRIPTION OF WORK:

To place fill below the OHW line of the Wilson Stream at Early's bridge in conjunction with the replacement of existing bridge abutments as described in the State of Maine Dept of Environmental Protection Permit By Rule application entitled "Town of Willimantic" and as shown on plans on 9 sheets dated "March 2010". Approximately 210 SF (0.005 acres) of stream bottom will be impacted by the project.
ADDITIONAL CONDITION: All in stream work is to be completed within the May 1 - August 14 in stream work window.

LAT/LONG COORDINATES : 45.3043062° N -69.3494932° W USGS QUAD: SEBEC LAKE WEST, ME

I. CORPS DETERMINATION:

Based on our review of the information you provided, we have determined that your project will have only minimal individual and cumulative impacts on waters and wetlands of the United States. Your work is therefore authorized by the U.S. Army Corps of Engineers under the enclosed Federal Permit, the Maine Programmatic General Permit (PGP). Accordingly, other than possibly performing a compliance inspection (condition 23 of the permit) at some later date, we do not plan to take any further action on this project.

You must perform the activity authorized herein in compliance with all the terms and conditions of the PGP [including any attached Additional Conditions and any conditions placed on the State 401 Water Quality Certification including any required mitigation]. Please review the enclosed PGP carefully, including the PGP conditions beginning on page 7, to familiarize yourself with its contents. You are responsible for complying with all of the PGP requirements; therefore you should be certain that whoever does the work fully understands all of the conditions. You may wish to discuss the conditions of this authorization with your contractor to ensure the contractor can accomplish the work in a manner that conforms to all requirements.

If you change the plans or construction methods for work within our jurisdiction, please contact us immediately to discuss modification of this authorization. This office must approve any changes before you undertake them.

Condition 38 of the PGP (page 15) provides one year for completion of work that has commenced or is under contract to commence prior to the expiration of the PGP on October 11, 2010. You will need to apply for reauthorization for any work within Corps jurisdiction that is not completed by October 11, 2011.

This authorization presumes the work shown on your plans noted above is in waters of the U.S. Should you desire to appeal our jurisdiction, please submit a request for an approved jurisdictional determination in writing to the undersigned.

No work may be started unless and until all other required local, State and Federal licenses and permits have been obtained. This includes but is not limited to a Flood Hazard Development Permit issued by the town if necessary.

II. STATE ACTIONS: PENDING [X], ISSUED [], DENIED [] DATE _____

APPLICATION TYPE: PBR X TIER 1: _____ TIER 2: _____ TIER 3: _____ LURC: _____ DMR LEASE: _____ NA: _____

III. FEDERAL ACTIONS:

JOINT PROCESSING MEETING: APRIL 2, 2010 LEVEL OF REVIEW: CATEGORY 1: _____ CATEGORY 2: X

AUTHORITY (Based on a review of plans and/or State/Federal applications): SEC 10 _____ 404 X 10/404 _____ 103 _____

EXCLUSIONS: The exclusionary criteria identified in the general permit do not apply to this project.

FEDERAL RESOURCE AGENCY OBJECTIONS: EPA NO USF&WS NO NMFS NO

If you have any questions on this matter, please contact my staff at 207-623-8367 at our Manchester, Maine Project Office. In order for us to better serve you, we would appreciate your completing our Customer Service Survey located at <http://per2.nwp.usace.army.mil/survey.html>

Leeann B. Neal
LEEANN B. NEAL
PROJECT MANAGER
MAINE PROJECT OFFICE

Frank J. Del Giudice
FRANK J. DEL GIUDICE
CHIEF, PERMITS & ENFORCEMENT BRANCH
REGULATORY DIVISION

TOPOI map printed on 03/17/10 from "Untitled.tpo"

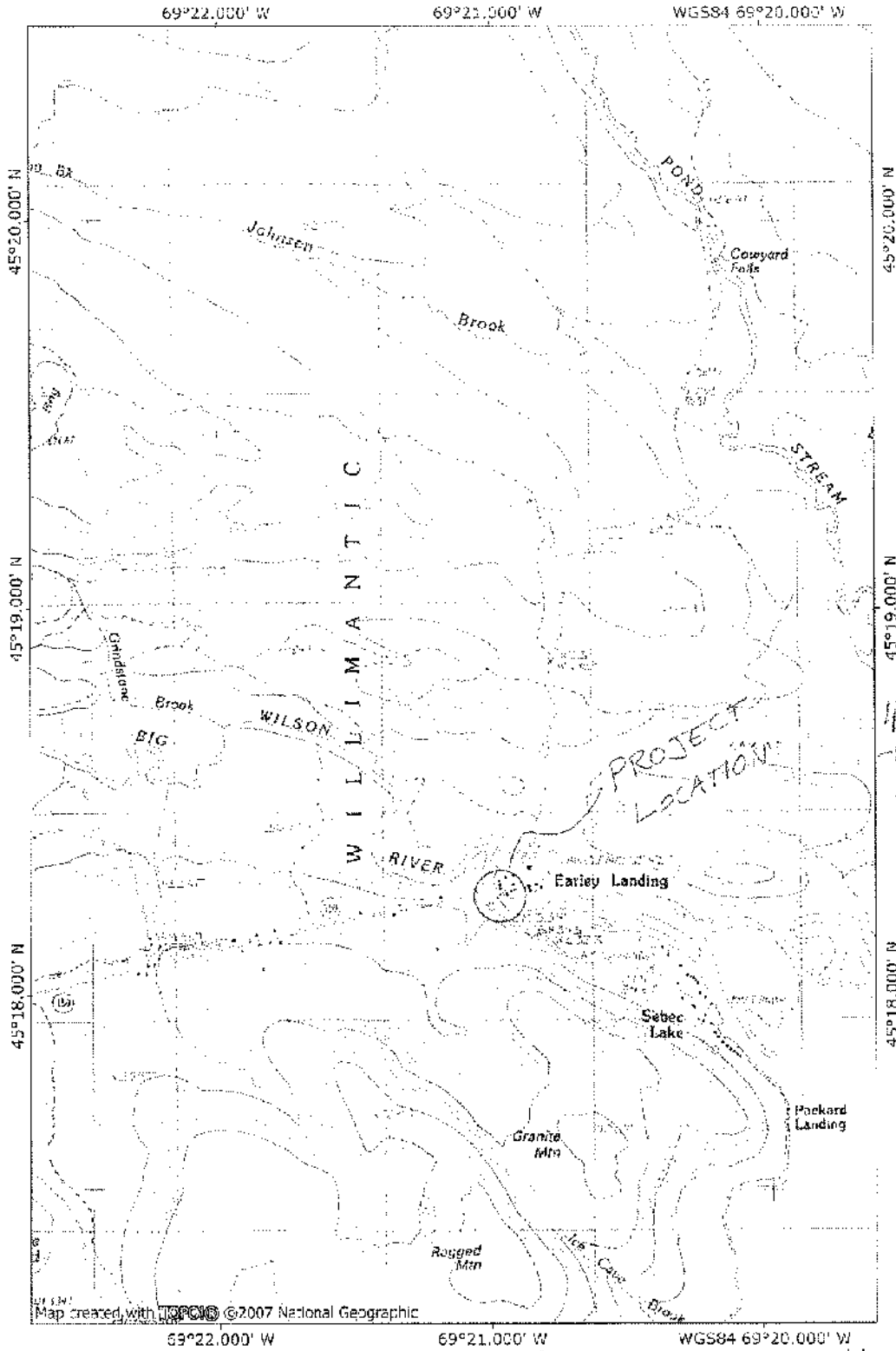

15, 501, 306, 21 N
- 14 349, 493, 21 W
Sebect Lake West

Map created with TOPOI © 2007 National Geographic

NATIONAL
GEOGRAPHIC



TYPICAL SECTION
 SCALE: 3/4"=1'-0"

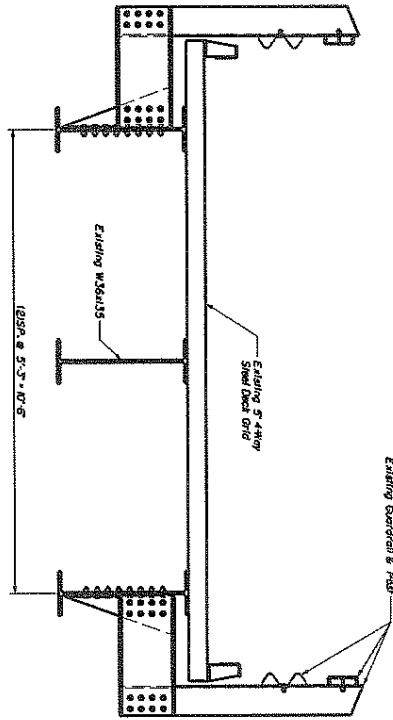

GENERAL PLAN
 SCALE: 3/4"=1'-0"

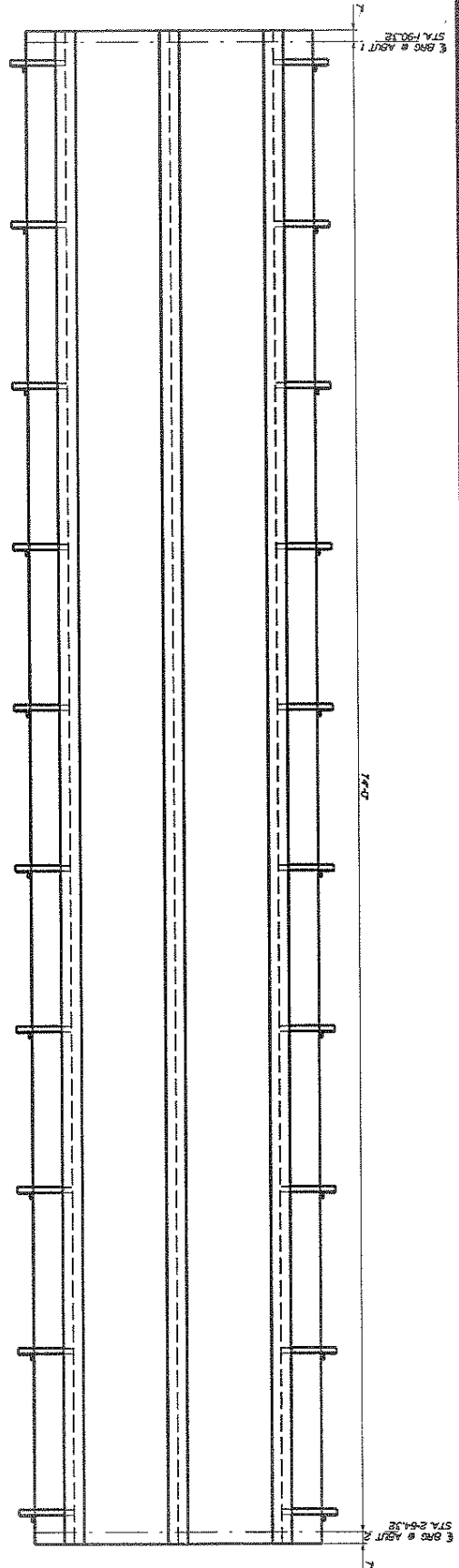

NOTES
 Contractor to remove 4" of Existing
 Steel Deck to allow for a 7'-0"
 span with a 73'-0" overall length.

"TOWN OF WILLIMANTIC"
 WILLIMANTIC, MAINE
 BRIGE ABUTMENT REPLACEMENT
 NAE-2010-00534
 PG 3 OF 9 "MARCH 2010"

2

SHEET NUMBER

EARLEY BRIDGE
 WILLIMANTIC MAINE

GENERAL PLAN

REVISION	BY	DATE
DESIGN-DRAWN	JER	DEC 08
CHECKED-REVIEWED		
REVISION 1		
REVISION 2		
REVISION 3		
REVISION 4		
DATE CHECKED		

P.I. NUMBER
 DATE MAY 2010

CALDERWOOD ENGINEERING, ETC.
 STRUCTURAL ENGINEERING • DETAILING SERVICES
 222 NHEP RD. RICHMOND, ME 04857 PH: 603-875-3200 / FAX: 603-875-3201
 PREPARED FOR
 TOWN OF WILLIMANTIC
 EARLEY BRIDGE
 WILLIMANTIC, MAINE

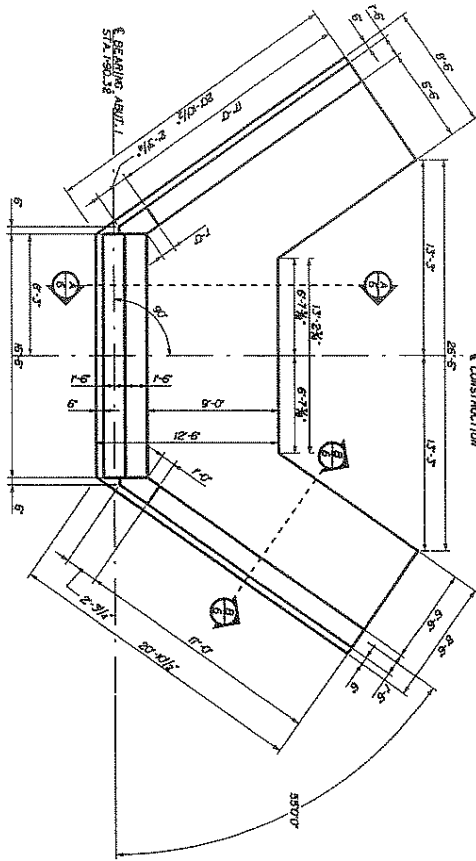

ABUTMENT PLAN
 1/4" = 1'-0"

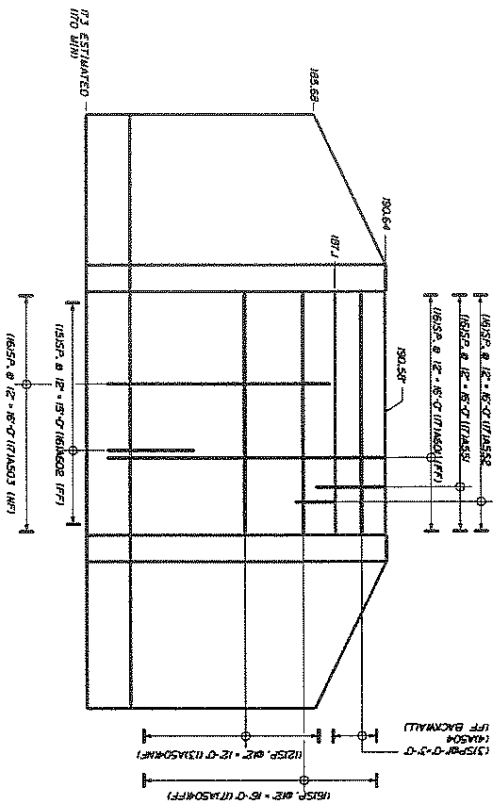

ABUTMENT ELEVATION
 Notes: A505 and A558 to only Shaded Anchor Rod locations

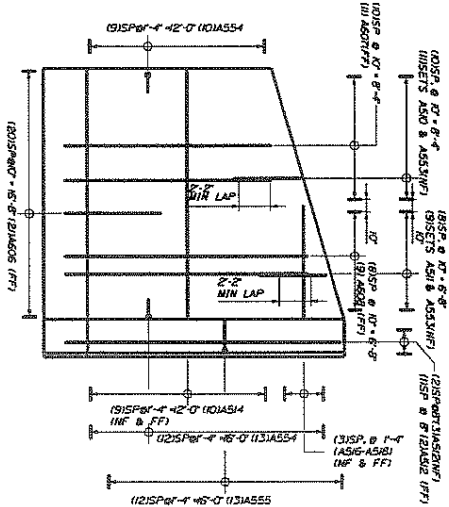

ABUTMENT REINFORCING ELEVATION
 1/4" = 1'-0"

"TOWN OF WILLIMANTIC"
 WILLIMANTIC, MAINE
 BRIDGE ABUTMENT REPLACEMENT
 NAE-2010-00534
 PG 4 OF 9 "MARCH 2010"



<p>3</p> <p>SHEET NUMBER</p>	<p>EARLEY BRIDGE</p> <p>WILLIMANTIC MAINE</p>	<table border="1"> <tr> <th>REV</th> <th>DATE</th> </tr> <tr> <td> </td> <td> </td> </tr> <tr> <td> </td> <td> </td> </tr> <tr> <td> </td> <td> </td> </tr> <tr> <td> </td> <td> </td> </tr> <tr> <td> </td> <td> </td> </tr> <tr> <td> </td> <td> </td> </tr> <tr> <td> </td> <td> </td> </tr> </table>	REV	DATE															<p>ITC</p> <p>P.E. NUMBER</p> <p>DATE: MAR 2010</p>	<p>CALDERWOOD ENGINEERING, ETC.</p> <p>STRUCTURAL ENGINEERING • DETAILING SERVICES</p> <p>222 RIVER RD., RICHMOND, ME 04351 PH/FX (207) 751-2201 11751-2005</p> <p>PREPARED FOR:</p> <p style="text-align: center;">TOWN OF WILLIMANTIC</p> <p style="text-align: center;">EARLEY BRIDGE</p> <p style="text-align: center;">WILLIMANTIC, MAINE</p>
	REV	DATE																		
<p>ABUTMENT 1</p>	<p style="text-align: right;">27</p>																			

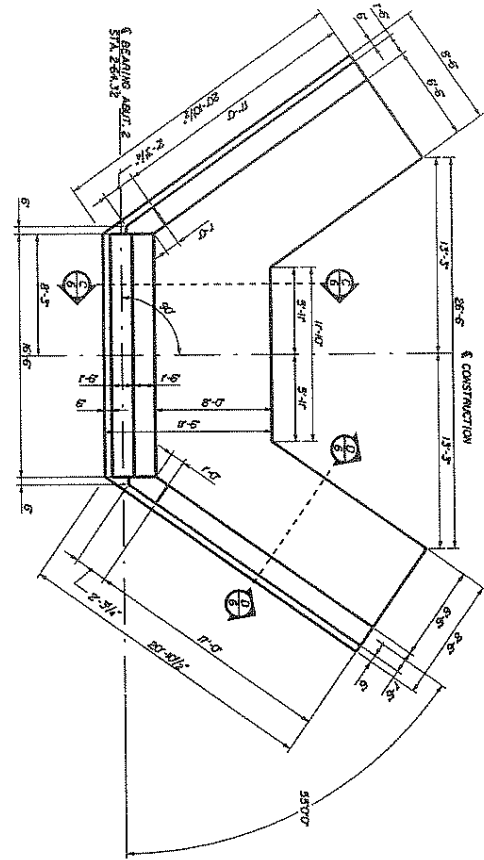

ABUTMENT 2 PLAN
 1/4"=1'-0"

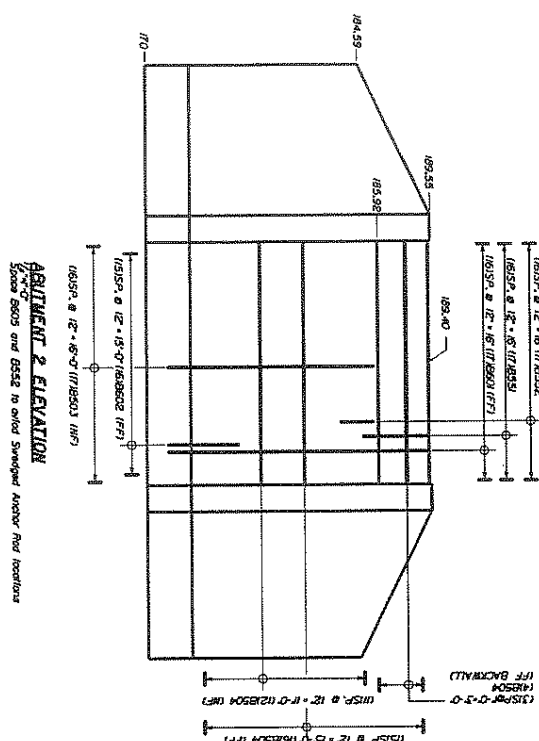

ABUTMENT 2 ELEVATION
 1/4"=1'-0"
 Section 8605 and 8552 to avoid Swept Anchor Rod Locations

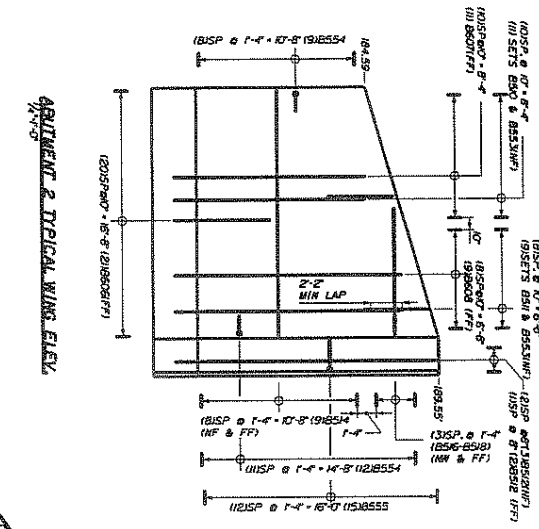

ABUTMENT 2 TYPICAL WING ELEV.
 1/4"=1'-0"

"TOWN OF WILLIMANTIC"
 WILLIMANTIC, MAINE
 BRIGE ABUTMENT REPLACEMENT
 NAE-2010-00534
 PG 5 OF 9 "MARCH 2010"



EARLEY BRIDGE
WILLIMANTIC MAINE
ABUTMENT 2

4
 SHEET NUMBER

NO.	BY	DATE
DESIGN	EC	MAR 2010
CHECKED	EC	
REVISION 1		
REVISION 2		
REVISION 3		
REVISION 4		
DATE	ISSUED	

CALDERWOOD ENGINEERING, ETC.
 STRUCTURAL ENGINEERING + DETAILING SERVICES
 222 RIVER RD. RICHMOND, ME 04857 PH/FX (207)731-2007 / (737) 300-6668
 PREPARED FOR: **TOWN OF WILLIMANTIC**
EARLEY BRIDGE
WILLIMANTIC, MAINE

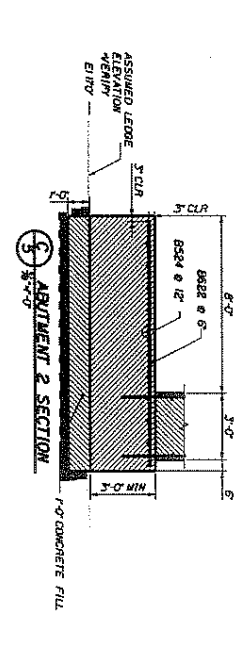
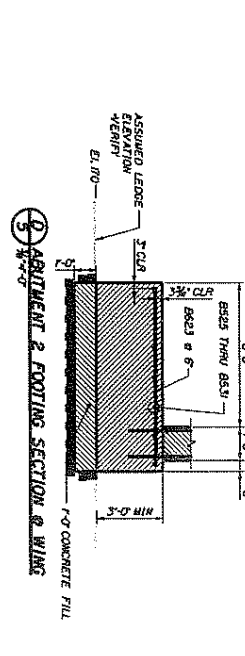
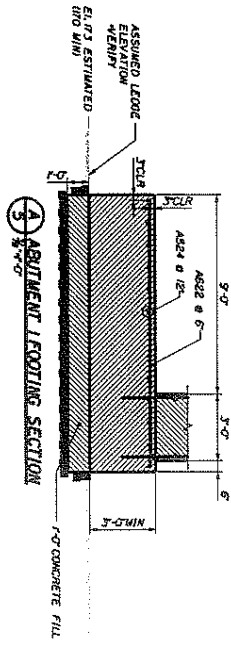
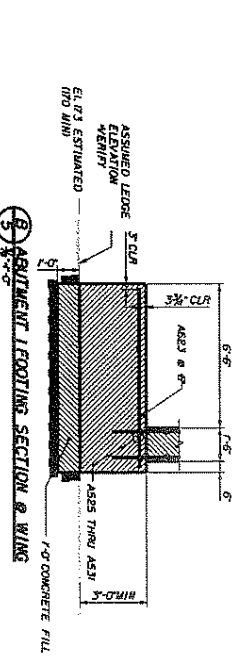
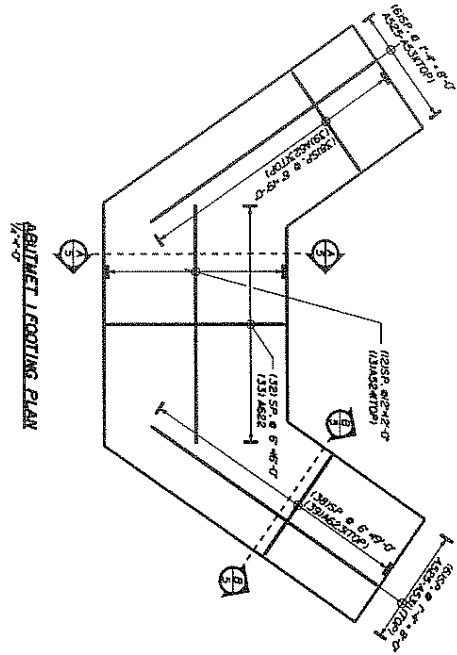
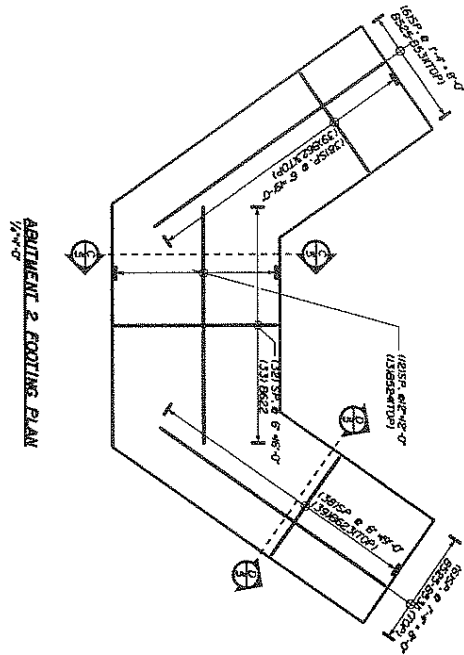

SHEET NUMBER 5	EARLEY BRIDGE WILLIMANTIC MAINE FOOTINGS	BY OC	DATE MAR 2010
		DESIGN-REVIEWED	
		PROJECT NUMBER NAE-2010-00534	DATE MAR 2010
		REVISIONS	
		REVISION 1	
		REVISION 2	
		REVISION 3	
		REVISION 4	
		DATE CHANGED	

"TOWN OF WILLIMANTIC"
 WILLIMANTIC, MAINE
 BRIGE ABUTMENT REPLACEMENT
 NAE-2010-00534
 PG 6 OF 9 "MARCH 2010"

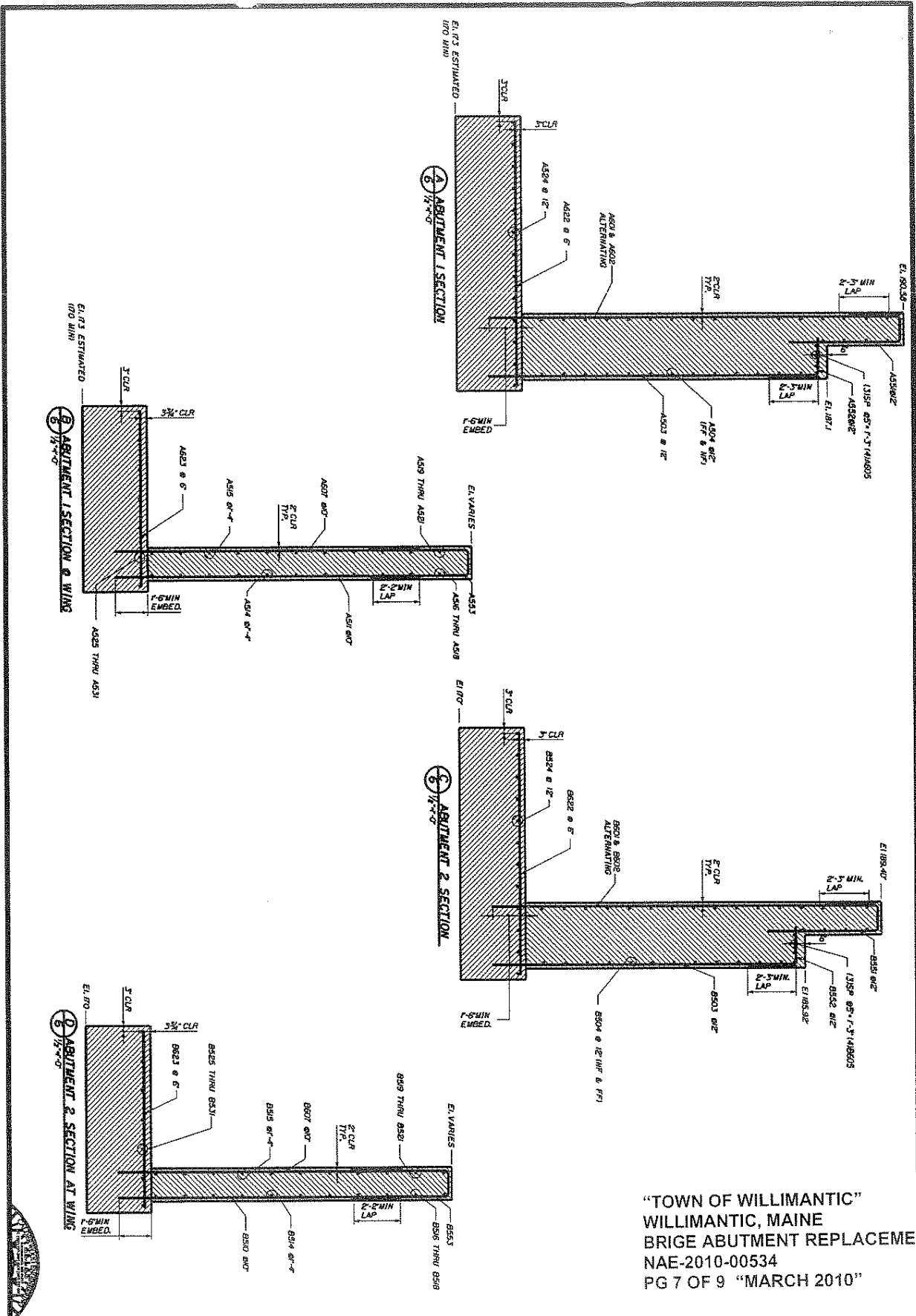

“TOWN OF WILLIMANTIC”
 WILLIMANTIC, MAINE
 BRIGE ABUTMENT REPLACEMENT
 NAE-2010-00534
 PG 7 OF 9 “MARCH 2010”

	EARLEY BRIDGE WILLIMANTIC MAINE ABUTMENT SECTIONS	<table border="1" style="width: 100%; border-collapse: collapse;"> <tr> <td>REV</td> <td>DATE</td> </tr> <tr> <td>1</td> <td>03/17/10</td> </tr> <tr> <td>2</td> <td>03/17/10</td> </tr> <tr> <td>3</td> <td>03/17/10</td> </tr> <tr> <td>4</td> <td>03/17/10</td> </tr> <tr> <td>5</td> <td>03/17/10</td> </tr> </table>	REV	DATE	1	03/17/10	2	03/17/10	3	03/17/10	4	03/17/10	5	03/17/10	<table border="1" style="width: 100%; border-collapse: collapse;"> <tr> <td>PROJECT</td> <td>NAE-2010-00534</td> </tr> <tr> <td>DATE</td> <td>03/17/10</td> </tr> <tr> <td>PREPARED BY</td> <td>ERIC CALDERWOOD</td> </tr> <tr> <td>CHECKED BY</td> <td>ERIC CALDERWOOD</td> </tr> <tr> <td>SCALE</td> <td>AS SHOWN</td> </tr> </table>	PROJECT	NAE-2010-00534	DATE	03/17/10	PREPARED BY	ERIC CALDERWOOD	CHECKED BY	ERIC CALDERWOOD	SCALE	AS SHOWN	<table border="1" style="width: 100%; border-collapse: collapse;"> <tr> <td> CALDERWOOD ENGINEERING, ETC. STRUCTURAL ENGINEERING • DISTALTING SERVICES 222 RIVER RD, RICHMOND, ME 04857 PH: 735.257.2211 FAX: 735.257.2212 </td> </tr> <tr> <td> PREPARED FOR: TOWN OF WILLIMANTIC EARLEY BRIDGE WILLIMANTIC, MAINE </td> </tr> </table>	CALDERWOOD ENGINEERING, ETC. STRUCTURAL ENGINEERING • DISTALTING SERVICES 222 RIVER RD, RICHMOND, ME 04857 PH: 735.257.2211 FAX: 735.257.2212	PREPARED FOR: TOWN OF WILLIMANTIC EARLEY BRIDGE WILLIMANTIC, MAINE
	REV	DATE																										
1	03/17/10																											
2	03/17/10																											
3	03/17/10																											
4	03/17/10																											
5	03/17/10																											
PROJECT	NAE-2010-00534																											
DATE	03/17/10																											
PREPARED BY	ERIC CALDERWOOD																											
CHECKED BY	ERIC CALDERWOOD																											
SCALE	AS SHOWN																											
CALDERWOOD ENGINEERING, ETC. STRUCTURAL ENGINEERING • DISTALTING SERVICES 222 RIVER RD, RICHMOND, ME 04857 PH: 735.257.2211 FAX: 735.257.2212																												
PREPARED FOR: TOWN OF WILLIMANTIC EARLEY BRIDGE WILLIMANTIC, MAINE																												
SHEET NUMBER 6																												

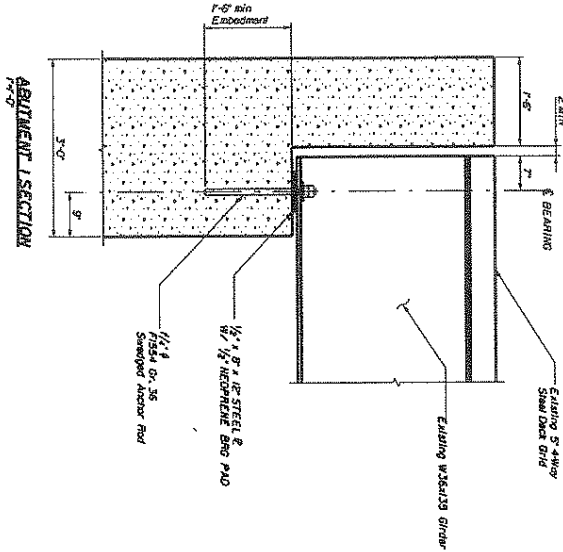

Elevation and Plan of Abutment 1

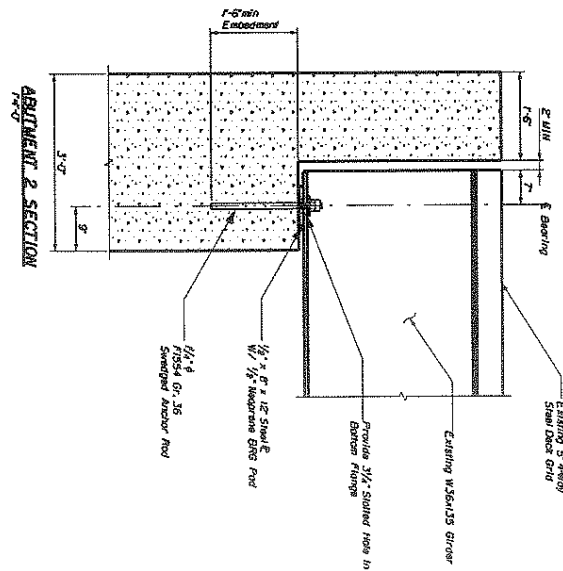
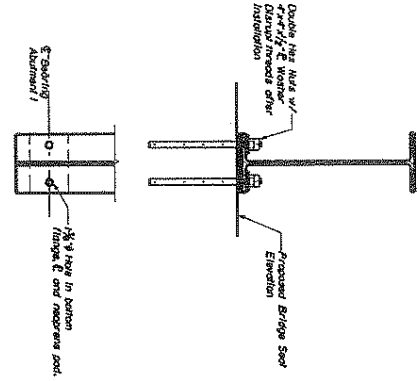

Elevation and Plan of Abutment 2

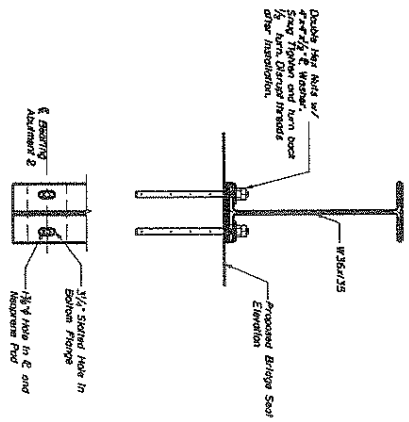

"TOWN OF WILLIMANTIC"
 WILLIMANTIC, MAINE
 BRIGE ABUTMENT REPLACEMENT
 NAE-2010-00534
 PG 8 OF 9 "MARCH 2010"



SHEET NUMBER 7	EARLEY BRIDGE WILLIMANTIC MAINE		<table border="1"> <thead> <tr> <th>REVISED</th> <th>BY</th> <th>DATE</th> </tr> </thead> <tbody> <tr> <td>DESIGN</td> <td>ER</td> <td>3/17/10</td> </tr> <tr> <td>CHECKED</td> <td>ER</td> <td>3/17/10</td> </tr> <tr> <td>REVISION 1</td> <td></td> <td></td> </tr> <tr> <td>REVISION 2</td> <td></td> <td></td> </tr> <tr> <td>REVISION 3</td> <td></td> <td></td> </tr> <tr> <td>REVISION 4</td> <td></td> <td></td> </tr> <tr> <td>REVISION 5</td> <td></td> <td></td> </tr> </tbody> </table>		REVISED	BY	DATE	DESIGN	ER	3/17/10	CHECKED	ER	3/17/10	REVISION 1			REVISION 2			REVISION 3			REVISION 4			REVISION 5			CALDERWOOD ENGINEERING, ETC. STRUCTURAL ENGINEERING + DETAILING SERVICES 222 RIVER RD., RICHMOND, ME 04367 PH/FX 603/751-2001 / 751-2005 PREPARED FOR: TOWN OF WILLIMANTIC EARLEY BRIDGE WILLIMANTIC, MAINE	
	REVISED	BY	DATE																											
DESIGN	ER	3/17/10																												
CHECKED	ER	3/17/10																												
REVISION 1																														
REVISION 2																														
REVISION 3																														
REVISION 4																														
REVISION 5																														
	BEARING DETAILS		P.E. NUMBER 1720	DATE: MAR 2010																										

MARK	SZ	QTY.	LENGTH	TYPE	LOCATION
A501	6	7	18'-0"	STR.	ABUTMENT VERTICAL STEEL (WF)
A502	6	16	9'-0"	STR.	ABUTMENT VERTICAL STEEL (WF)
A503	5	7	15'-3"	STR.	ABUTMENT VERTICAL STEEL (WF)
A504	5	13	16'-2"	STR.	ABUTMENT VERTICAL STEEL (WF)
A505	6	4	16'-2"	STR.	ABUTMENT 1 LONGITUDINAL BRIDGE SEAT STEEL
A506	6	20	6'-6"	STR.	ABUTMENT VERTICAL STEEL & WINGS (WF)
A507	5	12	14'-5"	STR.	ABUTMENT VERTICAL STEEL & WINGS (WF)
A508	6	10	16'-7"	STR.	ABUTMENT VERTICAL STEEL & WINGS (WF)
A509	5	12	14'-1"	STR.	ABUTMENT VERTICAL STEEL & WINGS (WF)
A510	5	10	16'-7"	STR.	ABUTMENT VERTICAL STEEL & WINGS (WF)
A511	5	6	16'-7"	STR.	ABUTMENT VERTICAL STEEL & WINGS (WF)
A512	5	6	16'-7"	STR.	ABUTMENT VERTICAL STEEL & WINGS (WF)
A513	5	20	15'-7"	STR.	ABUTMENT 1 LONGITUDINAL STEEL & WINGS (WF & FFI)
A514	5	2	15'-7"	STR.	ABUTMENT 1 LONGITUDINAL STEEL & WINGS (WF & FFI)
A515	5	2	15'-7"	STR.	ABUTMENT 1 LONGITUDINAL STEEL & WINGS (WF & FFI)
A516	5	2	15'-7"	STR.	ABUTMENT 1 LONGITUDINAL STEEL & WINGS (WF & FFI)
A517	5	2	15'-7"	STR.	ABUTMENT 1 LONGITUDINAL STEEL & WINGS (WF & FFI)
A518	5	2	15'-7"	STR.	ABUTMENT 1 LONGITUDINAL STEEL & WINGS (WF & FFI)
A519	5	2	15'-7"	STR.	ABUTMENT 1 LONGITUDINAL STEEL & WINGS (WF & FFI)
A520	5	2	15'-7"	STR.	ABUTMENT 1 LONGITUDINAL STEEL & WINGS (WF & FFI)
A521	5	2	15'-7"	STR.	ABUTMENT 1 LONGITUDINAL STEEL & WINGS (WF & FFI)
A522	6	33	16'-0"	STR.	ABUTMENT TRANSVERSE FOOTING STEEL (WINGTOP)
A523	6	78	8'-0"	STR.	ABUTMENT TRANSVERSE FOOTING STEEL (WINGTOP)
A524	5	13	16'-0"	STR.	ABUTMENT 1 LONGITUDINAL FOOTING STEEL (WINGTOP)
A525	5	2	12'-0"	STR.	ABUTMENT 1 LONGITUDINAL FOOTING STEEL (WINGTOP)
A526	5	2	14'-4"	STR.	ABUTMENT 1 LONGITUDINAL FOOTING STEEL (WINGTOP)
A527	5	2	14'-4"	STR.	ABUTMENT 1 LONGITUDINAL FOOTING STEEL (WINGTOP)
A528	5	2	14'-4"	STR.	ABUTMENT 1 LONGITUDINAL FOOTING STEEL (WINGTOP)
A529	5	2	14'-4"	STR.	ABUTMENT 1 LONGITUDINAL FOOTING STEEL (WINGTOP)
A530	5	2	14'-4"	STR.	ABUTMENT 1 LONGITUDINAL FOOTING STEEL (WINGTOP)
A531	5	2	14'-4"	STR.	ABUTMENT 1 LONGITUDINAL FOOTING STEEL (WINGTOP)
A532	5	2	14'-4"	STR.	ABUTMENT 1 LONGITUDINAL FOOTING STEEL (WINGTOP)
A533	5	2	14'-4"	STR.	ABUTMENT 1 LONGITUDINAL FOOTING STEEL (WINGTOP)
A534	5	2	14'-4"	STR.	ABUTMENT 1 LONGITUDINAL FOOTING STEEL (WINGTOP)
A535	5	2	14'-4"	STR.	ABUTMENT 1 LONGITUDINAL FOOTING STEEL (WINGTOP)

MARK	SZ	QTY.	LENGTH	TYPE	LOCATION
B501	6	7	17'-8"	STR.	ABUTMENT & VERTICAL STEEL (WF)
B502	6	16	4'-9"	STR.	ABUTMENT & VERTICAL STEEL (WF)
B503	5	7	14'-1"	STR.	ABUTMENT & VERTICAL STEEL (WF)
B504	5	12	16'-2"	STR.	ABUTMENT & VERTICAL STEEL (WF)
B505	6	4	16'-2"	STR.	ABUTMENT & VERTICAL STEEL & WINGS (WF)
B506	6	21	6'-6"	STR.	ABUTMENT & VERTICAL STEEL & WINGS (WF)
B507	6	11	15'-0"	STR.	ABUTMENT & VERTICAL STEEL & WINGS (WF)
B508	6	11	15'-0"	STR.	ABUTMENT & VERTICAL STEEL & WINGS (WF)
B509	5	11	15'-0"	STR.	ABUTMENT & VERTICAL STEEL & WINGS (WF)
B510	5	11	15'-0"	STR.	ABUTMENT & VERTICAL STEEL & WINGS (WF)
B511	5	9	15'-7"	STR.	ABUTMENT & VERTICAL STEEL & WINGS (WF)
B512	5	9	15'-7"	STR.	ABUTMENT & VERTICAL STEEL & WINGS (WF)
B513	5	18	16'-9"	STR.	ABUTMENT & VERTICAL STEEL & WINGS (WF)
B514	5	18	16'-9"	STR.	ABUTMENT & VERTICAL STEEL & WINGS (WF)
B515	5	2	14'-5"	STR.	ABUTMENT & VERTICAL STEEL & WINGS (WF)
B516	5	2	14'-5"	STR.	ABUTMENT & VERTICAL STEEL & WINGS (WF)
B517	5	2	14'-5"	STR.	ABUTMENT & VERTICAL STEEL & WINGS (WF)
B518	5	2	14'-5"	STR.	ABUTMENT & VERTICAL STEEL & WINGS (WF)
B519	5	2	14'-5"	STR.	ABUTMENT & VERTICAL STEEL & WINGS (WF)
B520	5	2	14'-5"	STR.	ABUTMENT & VERTICAL STEEL & WINGS (WF)
B521	5	2	14'-5"	STR.	ABUTMENT & VERTICAL STEEL & WINGS (WF)
B522	6	33	17'-0"	STR.	ABUTMENT & TRANSVERSE FOOTING STEEL
B523	6	78	8'-0"	STR.	ABUTMENT & TRANSVERSE FOOTING STEEL
B524	5	13	16'-0"	STR.	ABUTMENT & LONGITUDINAL FOOTING STEEL
B525	5	2	14'-0"	STR.	ABUTMENT & LONGITUDINAL FOOTING STEEL & WING
B526	5	2	14'-0"	STR.	ABUTMENT & LONGITUDINAL FOOTING STEEL & WING
B527	5	2	14'-0"	STR.	ABUTMENT & LONGITUDINAL FOOTING STEEL & WING
B528	5	2	14'-0"	STR.	ABUTMENT & LONGITUDINAL FOOTING STEEL & WING
B529	5	2	14'-0"	STR.	ABUTMENT & LONGITUDINAL FOOTING STEEL & WING
B530	5	2	14'-0"	STR.	ABUTMENT & LONGITUDINAL FOOTING STEEL & WING
B531	5	2	14'-0"	STR.	ABUTMENT & LONGITUDINAL FOOTING STEEL & WING
B532	5	2	14'-0"	STR.	ABUTMENT & LONGITUDINAL FOOTING STEEL & WING
B533	5	2	14'-0"	STR.	ABUTMENT & LONGITUDINAL FOOTING STEEL & WING
B534	5	2	14'-0"	STR.	ABUTMENT & LONGITUDINAL FOOTING STEEL & WING
B535	5	2	14'-0"	STR.	ABUTMENT & LONGITUDINAL FOOTING STEEL & WING

MARK	SZ	QTY.	LENGTH	TYPE	A	B	C	D	E	F	G	H	O	R	LOCATION
A531	5	7	8'-3"	S	...	8'-3"	7'-8"	5'-0"							ABUTMENT 1 BACKWALL STRIP
A532	5	7	3'-11"	L	2'-3"	1'-9"	1'-2"	4'-6"							ABUTMENT 1 BACKWALL STRIP
A533	5	19	12'-6"	S	...	4'-6"	1'-2"	4'-6"							ABUTMENT 1 WINGWALL STRIP
A534	5	23	8'-4"	S	...	8'-2"	1'-0"	8'-2"							ABUTMENT 1 WINGWALL STRIP
A535	5	13	4'-3"	CB	...	2'-0"	3/4"	1'-7"	9"						ABUTMENT 1 WINGWALL STRIP
B536	5	7	8'-3"	S	...	8'-3"	7'-8"	5'-0"							ABUTMENT & BACKWALL STRIP
B537	5	7	3'-11"	L	2'-3"	1'-9"	1'-2"	4'-6"							ABUTMENT & BACKWALL STRIP
B538	5	20	12'-6"	S	...	4'-6"	1'-2"	4'-6"							ABUTMENT & WINGWALL STRIP
B539	5	24	8'-4"	S	...	8'-2"	1'-0"	8'-2"							ABUTMENT & WINGWALL STRIP
B540	5	14	4'-3"	CB	...	2'-0"	3/4"	1'-7"	9"						ABUTMENT & WINGWALL STRIP

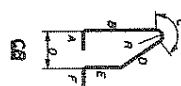

TYPE - BENDING DIAGRAMS

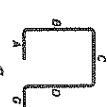

"TOWN OF WILLIMANTIC"
WILLIMANTIC, MAINE
BRIGE ABUTMENT REPLACEMENT
NAE-2010-00534
PG 9 OF 9 "MARCH 2010"

<p>8</p> <p>SHEET NUMBER</p>	<p>EARLEY BRIDGE</p> <p>WILLIMANTIC MAINE</p> <p>STEEL REINFORCING SCHEDULE</p>	<p>DATE: MAR 2010</p>	<p>DATE: MAR 2010</p>
		<p>PREPARED FOR: TOWN OF WILLIMANTIC</p>	<p>DATE: MAR 2010</p>

Applicant: General Public, State of Maine

Effective Date: October 11, 2005
Expiration Date: October 11, 2010

**DEPARTMENT OF THE ARMY
PROGRAMMATIC GENERAL PERMIT
STATE OF MAINE**

The New England District of the U.S. Army Corps of Engineers hereby issues a Programmatic General Permit (PGP) that expedites review of minimal impact work in coastal and inland waters and wetlands within the State of Maine.

I. GENERAL CRITERIA

Activities with minimal impacts, as specified by the terms and conditions of this PGP and on the attached Appendix A, Definition of Categories, are either:

Category 1: Non-reporting. Eligible without screening (provided the authorizations are obtained which this permit states are necessary for activities to be eligible for authorization under this non-reporting category), or,

Category 2: Reporting. Require screening and a written determination of eligibility under the PGP by the Corps after coordination with the U.S. Fish and Wildlife Service (U.S. FWS), U.S. Environmental Protection Agency (EPA) and the National Marine Fisheries Service (NMFS).

This PGP does not affect the Corps Individual Permit review process or activities exempt from Corps jurisdiction.

II. ACTIVITIES COVERED:

Work and structures that are located in, or that affect, navigable waters of the United States (U.S.) (Corps regulates under Section 10 of the Rivers and Harbors Act of 1899); the discharge of dredged or fill material into waters of the United States (Corps regulates under Section 404 of the Clean Water Act); and the transportation of dredged material for the purpose of disposal in the ocean (Corps regulates under Section 103 of the Marine Protection, Research and Sanctuaries Act).

III. PROCEDURES:

A. State Approvals

For projects authorized pursuant to this PGP, the following State approvals are also required. The applicable permits must be obtained in order for this PGP authorization to be valid (applicants are responsible for ensuring that all required State permits and approvals have been applied for and obtained):

- Maine Department of Environmental Protection (DEP): Natural Resources Protection Act (NRPA) permit, including permit-by-rule and general permit authorizations (NRPA permit issuance constitutes both the state permit and the WQC); Site Location of Development Act permit; and Maine Waterway Development and Conservation Act permit.
- Maine Department of Conservation: Land Use Regulation Commission (LURC) permit.
- Maine Department of Marine Resources: Lease.
- Maine Department of Conservation, Bureau of Parks and Lands, Submerged Lands: Lease

NOTE: This PGP may authorize projects that are not regulated by the State of Maine (e.g., seasonal floats or moorings).

B. Corps Authorizations

CATEGORY 1 (Non-Reporting)

Eligibility Criteria

Activities in Maine may proceed without application or notification to the Corps if they:

- Are subject to Corps jurisdiction (see General Condition 2, Page 7),
- Meet the definition of Category 1 in Appendix A - Definition of Categories, and
- Meet the General Conditions of the PGP (see Pages 7 - 15).

If the State or the Corps does not contact the applicant for DEP's Tier One permits during the DEP's Tier One 30-day review period, Corps approval may be assumed and the project may proceed. Refer to the Federal Screening Procedures (see Page 4) for additional information regarding screening.

Project proponents seeking Category 1 authorizations are not relieved of the obligation to comply with this PGP's General Conditions (see Page 7) and other Federal laws such as the National Historic Preservation Act, the Endangered Species Act (ESA) and the Wild and Scenic Rivers Act. Therefore, consultation with the Corps and/or outside experts such as the Maine Historic Preservation Commission and the appropriate Indian tribes is recommended when there is a high likelihood of the presence of resources of concern.

Although Category 1 projects are non-reporting, the Corps reserves the right to require screening under Category 2 or Individual Permit review if there are concerns for the aquatic environment or any other factor of the public interest (see General Condition 4, Discretionary Authority, Page 7).

Work that is not regulated by the State of Maine, but is subject to Corps jurisdiction, is eligible for Corps authorization under this PGP in accordance with the review thresholds and conditions contained herein. The Maine DEP and LURC have waived WQC for projects authorized under Categories 1 and 2 of this PGP and not subject to jurisdiction under the NRPA and LURC Land Use Districts and Standards.

Enforcement cases. This PGP does not apply to any existing or proposed activity in Corps jurisdiction associated with an on-going Corps or EPA enforcement action until such time as the enforcement action is resolved or the Corps determines that the activity may proceed independently without compromising the enforcement action. The Corps may choose not to accept applications or issue permits to any applicant with outstanding violations.

CATEGORY 2 (Reporting – Requiring Screening)

Eligibility Criteria

Activities in Maine require written approval from the Corps if they:

- Are subject to Corps jurisdiction (see General Condition 2, Page 7),
- Meet the definition of Category 2 in Appendix A - Definition of Categories, and
- Meet the General Conditions of the PGP (see Pages 7 - 15),

These projects will be reviewed through interagency screening (see Federal Screening Procedures below) to determine whether such activities may be authorized under this PGP. To be eligible and

subsequently authorized, an activity must result in minimal impacts to the aquatic environment as determined by the Corps based on comments from the review team and the criteria listed above. Mitigation may be required to compensate for unavoidable impacts to ensure net effects of a project are minimal.

For Category 2 projects, applicants must obtain a written authorization from the Corps and State approvals as stated on Page 1.

To ensure compliance with the conditions of this PGP, consultation with the Corps and outside experts is required. This includes consultation with the Maine Historic Preservation Commission and the appropriate Native American Indian tribes to ensure compliance with Condition 8. Also, note the review thresholds under Category 2 apply to single and complete projects only (see General Condition 5).

Enforcement cases. See previous section.

Application Procedures

The Corps must review and approve in writing all Category 2 activities. Generally, the State will provide the Corps with a copy of State applications received, but it is ultimately the applicant's responsibility to ensure the Corps receives the application from the State. Therefore, it is recommended that applicants either verify with the Corps receipt of their application from the State (DEP or LURC), or apply directly to the Corps with either a copy of their State application or a Corps application (ENG Form 4345). Applicants must apply directly to the Corps using ENG Form 4345 if the work is not State regulated.

Upon receipt of the application, the Corps will determine if it:

- (a) requires additional information (see "information typically required" on the following page);
- (b) is appropriate for screening with the Federal resource agencies (see Category 2 Federal Screening Procedures on the following page);
- (c) is ineligible under the terms and/or conditions of this PGP; or
- (d) will require Individual Permit review, regardless of whether the terms and conditions of this PGP are met, based on concerns for the aquatic environment or any other factor of the public interest (see General Condition 4, Discretionary Authority).

If open water disposal is proposed, the Corps will make a suitability determination, fully coordinated with the Federal resource agencies, before coordinating a project at a joint processing meeting.

All Category 2 applicants shall submit a copy of their application materials to the Maine Historic Preservation Commission and the Indian tribe(s) listed on Page 17, at the same time, or before, they apply to the DEP, LURC, or the Corps, to be reviewed for the presence of historic, archaeological or tribal resources in the permit area that the proposed work may affect. Submittals to the DEP or Corps shall include information to indicate that this has been done (a copy of the applicant's cover letter to Maine Historic Preservation Commission and tribes or a copy of the Historic Preservation Commission and tribal response letters is acceptable).

Information Typically Required

The following information may not be necessary for all projects. Please see www.nae.usace.army.mil for a more comprehensive checklist. Select "Regulatory/Permitting," "Forms" and then "Application and Plan Guideline Checklist." Please check with our Maine office for project-specific requirements.

- (a) purpose of project;
- (b) 8½"x 11" locus map. 8½"x 11" plan views of the entire property, including property lines, and project limits with existing and proposed conditions;
- (c) typical cross-section views of all wetland and waterway fill areas and wetland replication areas;
- (d) legible, reproducible plans. Show mean low water (MLW), mean high water (MHW) and high tide line (HTL) elevations in navigable waters;
- (e) each plan should show the NGVD 1929 equivalent for the project's vertical datum (MLW, MLLW, MHW, HTL or other tidal datum for tidal projects) with the vertical units. Do not use local datum;
- (f) wetland delineation for the site, Corps wetland delineation data sheets (see web site), and calculations of waterway and wetland impact areas (see General Condition 2);
- (g) delineation of submerged aquatic vegetation, e.g., eel grass beds, in tidal waters;
- (h) volume, type and source of fill material to be discharged into waters and wetlands, including the area(s) (in square feet or acres) of fill in wetlands, below ordinary high water in inland waters and below the high tide line in coastal waters;
- (i) limits of any Federal Navigation Project in the vicinity and State Plane Coordinates for the limits of the proposed work closest to the Federal Navigation Project;
- (j) on-site alternatives analysis. Please contact Corps for guidance;
- (k) identify and describe potential impacts to Essential Fish Habitat. See General Condition 11 and contact Corps for guidance;
- (l) photographs of wetland/waterway to be impacted.

Information typically required for dredging projects:

- (a) sediment testing, including physical (e.g., grain-size analysis), chemical and biological testing. For projects proposing open water disposal, applicants are encouraged to contact the Corps as early as possible regarding sampling and testing protocols. Sampling and testing of sediments without such contact should not occur and, if done, would be at the applicant's risk.
- (b) the area in square feet and volume of material to be dredged below mean high water;
- (c) existing and proposed water depths;
- (d) type of dredging equipment to be used;
- (e) nature of material (e.g., silty sand);
- (f) any existing sediment grain size and bulk sediment chemistry data for the proposed or any nearby projects;
- (g) information on the location and nature of municipal or industrial discharges and occurrence of any contaminant spills in or near the project area, location of the disposal site (include locus sheet);
- (h) shellfish survey;
- (i) identify and describe potential impacts to Essential Fish Habitat (see General Condition 11);
- (j) delineation of submerged aquatic vegetation (e.g., eelgrass beds).

Federal Screening Procedures

The Corps will review all complete applications for Category 2 projects requiring Corps approval at interagency screening meetings (or "joint processing" meetings) with the Federal resource agencies (U.S. FWS, EPA and NMFS) to determine whether such activities may be authorized under this PGP. The Federal resource agencies will comprise the interagency review team. The meetings are held at the Corps every three weeks, or coordinated as necessary to provide applicants with a timely response. The Corps and Federal resource agencies, at the branch chief or equivalent level, may agree on certain activities that do not need to be coordinated at these meetings.

If the Corps and Federal resource agencies determine that the activity is eligible for the PGP, the Corps will send an authorization letter directly to the applicant. The Corps will generally issue an eligibility determination within the State's review period, not to exceed 60 days. If the Corps determines that the activity is not eligible under the PGP or that additional information is required, the Corps will notify the applicant in writing and will send a copy of this notification to DEP or LURC.

For projects reviewed with the Federal resource agencies, the agencies may recommend, within ten business days, either 1) special conditions for projects to avoid or minimize adverse environmental effects and to ensure the terms and conditions of the PGP are met, or 2) Individual Permit review. The Corps will determine that a project is ineligible under this PGP and will begin its Individual Permit review procedures if any one of the Federal resource agencies, within ten business days of the screening meeting, expresses a concern within their area of expertise, states the resource or species that could be impacted by the project, and describes the impacts that, either individually or cumulatively, will be more than minimal.

This ten-day notice may be spoken and is not required to be fully documented, but must be confirmed with a written response within an additional ten working days from the date of the spoken comment. Written responses must be signed by the Federal resource agency field supervisor or branch chief, as appropriate, and must identify the affected resource within their area of expertise. The intent of the spoken notification is to allow the Corps to give timely notification to the applicant that additional information is needed and/or an Individual Permit may be required. The Corps may reinstate a project's eligibility under the PGP provided the Federal agencies' concerns are satisfied. The Federal resource agencies may request additional information within their area of expertise within ten business days of the screening meeting. This information shall be commensurate to the level of impact and agreed upon by the Corps. The agencies are allowed an additional ten business days after their receipt of additional information to provide special conditions or a written Individual Permit request to the Corps.

If the applicant is unable to resolve the concerns, the Corps, independently or at the request of the Federal resource agencies, will require an Individual Permit for the project. The applicant will be notified of this in writing, along with information about submitting the necessary application materials.

Minerals Management Service (MMS) Review

Projects with construction of solid fill structures or discharge of fill that may extend beyond the coastline or the baseline from which the territorial sea is measured (i.e., mean low water), must be coordinated with Minerals Management Service (MMS), Outer Continental Shelf (OCS) Survey Group, pursuant to the Submerged Lands Act (43 USC, Section 1301-1315, 33 CFR 320.4(f)). The Corps will forward project information to MMS for their review. The MMS will coordinate their determination with the Department of the Interior (DOI) Solicitor's Office. The DOI will have 15 calendar days from the date MMS is in receipt of project information to determine if the baseline will be affected. No notification to the Corps within 15-day review period will constitute a "no effect" determination. Otherwise, the solicitor's notification to the Corps may be spoken but must be followed with a written confirmation within ten business days from the date of the spoken notification. This procedure will be eliminated if the State of Maine provides a written waiver of interest in any increase in submerged lands caused by a change in the baseline resulting from solid fill structures or fills authorized under this PGP.

Emergency Situations Procedures

Emergency situations are limited to sudden, unexpected occurrences that could potentially result in an unacceptable hazard to life, a significant loss of property, or an immediate, unforeseen, and significant economic hardship if corrective action requiring a permit is not undertaken within a time period less than the normal time needed to process an application under standard procedures. If an emergency situation requires action in less than 30 days after the occurrence, it qualifies for the amended notification procedures described below.

Notification Procedures for Emergency Situations:

Any project proponent may request emergency authorization from the Corps, however the Corps will determine if a project qualifies for these emergency situation procedures. The Federal resource agencies, the Maine Historic Preservation Commission and the tribes will each designate an emergency contact and an alternate in the event the regular contact is unavailable. When an application for Category 2 work is received that the Corps determines is an “emergency” as defined above, the Corps will fax a copy of the plans and Determination of Eligibility to the agency representatives and their alternates. The resource agencies would then have 16 business hours to notify the Corps if they have any comments on authorization of the project under the PGP. Objections to the Corps determination of an “emergency” situation will not be accepted. If no response is received within 16 business hours, the Corps will proceed with a decision on the application. If the resource agencies have comments on the proposal, they will have 16 business hours to put their comments in writing. If written comments from the Federal agencies are not received within 16 business hours, the Corps will proceed with a decision on the application.

If a Federal agency requests that an Individual Permit be required for a project or requests modifications to the project based on concerns within their area(s) of expertise, the Corps will notify the applicant within one business day of receipt of that request that the project as proposed does not qualify for authorization under this PGP and the emergency Individual Permit procedures may be followed. In any event, the Corps will notify the applicant within 16 business hours of commencement of the screening process as to whether the project may proceed under this PGP.

IV. CORPS AUTHORIZATION: INDIVIDUAL PERMIT

Work that is defined in the Individual Permit category of Appendix A – Definition of Categories, or that does not meet the terms and conditions of this PGP, will require an application for an Individual Permit from the Corps (see 33 CFR Part 325.1). The screening procedures outlined for Category 2 projects will only serve to delay project review in such cases. The applicant should submit the appropriate application materials (including the Corps application form) at the earliest possible date. General information and application forms can be obtained at our web site or by calling us (see Page 16). Individual water quality certification and coastal zone management consistency concurrence are required when applicable from the State of Maine before Corps permit issuance. The Federal resource agencies’ comments are due within ten working days after the Public Notice’s expiration date, unless the Corps receives and approves a written request for a time extension within ten working days after the notice’s expiration.

V. PROGRAMMATIC GENERAL PERMIT CONDITIONS:

The following conditions apply to activities authorized under this Maine PGP, including all Category 1 (non-reporting) and Category 2 (reporting – requiring screening) activities:

General Requirements

1. Other Permits. Authorization under this PGP does not obviate the need to obtain other Federal, State, or local authorizations required by law. This includes, but is not limited to, the project proponent obtaining a Flood Hazard Development Permit issued by the town, if necessary. Inquiries may be directed to the municipality or to the Maine Floodplain Management Coordinator at (207) 287-8063. See <http://www.maine.gov>.

2. Federal Jurisdictional Boundaries. Applicability of this PGP shall be evaluated with reference to Federal jurisdictional boundaries. Applicants are responsible for ensuring that the boundaries used satisfy the Federal criteria defined at 33 CFR 328-329. These sections prescribe the policy, practice and procedures to be used in determining the extent of jurisdiction of the Corps concerning “waters of the U.S.” and “navigable waters of the U.S.” Wetland boundaries shall be delineated in accordance with the January 1987 Corps of Engineers Wetlands Delineation Manual, located at <http://www.usace.army.mil/inet/functions/cw/cecwo/reg/wlman87.pdf>. The U.S. FWS publishes the National List of Plant Species that Occur in Wetlands, located at <http://www.nwi.fws.gov>. The Natural Resources Conservation Service (NRCS) develops the hydric soil definition and criteria, and publishes the current hydric soil lists, located at <http://soils.usda.gov/use/hydric/>.

3. Minimal Effects. Projects authorized by this PGP shall have no more than minimal individual and cumulative adverse environmental impacts as determined by the Corps.

4. Discretionary Authority. Notwithstanding compliance with the terms and conditions of this permit, the Corps retains discretionary authority to require Category 2 or Individual Permit review based on concerns for the aquatic environment or for any other factor of the public interest [33 CFR 320.4(a)]. This authority is invoked on a case-by-case basis whenever the Corps determines that the potential consequences of the proposal warrant Individual Permit review based on the concerns stated above. This authority may be invoked for projects with cumulative environmental impacts that are more than minimal or if there is a special resource or concern associated with a particular project that is not already covered by the remaining conditions of the PGP and that warrants greater review. Whenever the Corps notifies an applicant that an Individual Permit may be required, authorization under this PGP is void and no work may be conducted until the individual Corps permit is obtained or until the Corps notifies the applicant that further review has demonstrated that the work may proceed under this PGP.

5. Single and Complete Projects. This PGP shall not be used for piecemeal work and shall be applied to single and complete projects. All components of a single project shall be treated together as constituting one single and complete project and/or all planned phases of a multi-phased project (e.g., subdivisions should include all work such as roads, utilities, and lot development) unless the Corps determines that a component has independent utility. (The *Independent Utility* test is used to determine what constitutes a single and complete project in the Corps regulatory program. A project is considered to have independent utility if it would be constructed absent the construction of other projects in the project area. Portions of a multi-phase project that depend upon other phases of the project do not have independent utility. Phases of a project that would be constructed even if the other phases were not built can be considered as separate single and complete projects with independent utility.) For linear projects, such as power lines or pipelines with multiple

crossings, the "single and complete project" (i.e., single and complete crossing) will apply to each crossing of a separate water of the U.S. (i.e., single waterbody) at that location; except that for linear projects crossing a single waterbody several times at separate and distant locations, each crossing is considered a single and complete project, and may be reviewed for Category 1 eligibility. (However, individual channels in a braided stream or river, or individual arms of a large, irregularly-shaped wetland or lake, etc., are not separate waterbodies.) If any crossing requires a Category 2 activity, then the entire linear project shall be reviewed as one project under Category 2. Also, this PGP shall not be used for any activity that is part of an overall project for which an Individual Permit is required, unless the Corps determines the activity has independent utility.

6. Permit On-Site. For Category 2 projects, the permittee shall ensure that a copy of this PGP and the accompanying authorization letter are at the work site (and the project office) authorized by this PGP whenever work is being performed, and that all personnel with operation control of the site ensure that all appropriate personnel performing work are fully aware of its terms and conditions. The entire permit authorization shall be made a part of any and all contracts and sub-contracts for work that affects areas of Corps jurisdiction at the site of the work authorized by this PGP. This shall be achieved by including the entire permit authorization in the specifications for work. The term "entire permit authorization" means this PGP and the authorization letter (including its drawings, plans, appendices and other attachments) and also includes permit modifications. If the authorization letter is issued after the construction specifications, but before receipt of bids or quotes, the entire permit authorization shall be included as an addendum to the specifications. If the authorization letter is issued after receipt of bids or quotes, the entire permit authorization shall be included in the contract or sub-contract as a change order. Although the permittee may assign various aspects of the work to different contractors or sub-contractors, all contractors and sub-contractors shall be obligated by contract to comply with all environmental protection provisions contained within the entire PGP authorization, and no contract or sub-contract shall require or allow unauthorized work in areas of Corps jurisdiction.

National Concerns

7. St. John/St. Croix Rivers. This covers work within the Saint John and Saint Croix River basins that requires approval of the International Joint Commission. This includes any temporary or permanent use, obstruction or diversion of international boundary waters which could affect the natural flow or levels of waters on the Canadian side of the line, as well as any construction or maintenance of remedial works, protective works, dams, or other obstructions in waters downstream from boundary waters when the activity could raise the natural level of water on the Canadian side of the boundary.

8. Historic Properties. Any activity authorized by this PGP shall comply with Section 106 of the National Historic Preservation Act. Information on the location and existence of historic resources can be obtained from the Maine Historic Preservation Commission, the National Register of Historic Places, and the Penobscot, Passamaquoddy, Micmac, and Maliseet Tribal Historic Preservation Officers. See Page 17 for historic properties contacts. If the permittee, either prior to construction or during construction of the work authorized herein, encounters a previously unidentified archaeological or other cultural resource, within the area subject to Department of the Army jurisdiction, that might be eligible for listing in the National Register of Historic Places, he/she shall stop work and immediately notify the District Engineer and the Maine Historic Preservation Commission and/or applicable Tribe(s).

9. National Lands. Activities authorized by this PGP shall not impinge upon the value of any National Wildlife Refuge, National Forest, National Marine Sanctuary, National Park or any other area administered by the National Park Service.

10. Endangered Species. No activity may be authorized under this PGP which:

- is likely to adversely affect a threatened or endangered species, a proposed species, designated critical habitat, or proposed critical habitat as identified under the Federal ESA,
- would result in a “take” of any threatened or endangered species of fish or wildlife, or
- would result in any other violation of Section 9 of the ESA protecting threatened or endangered species of plants.

Applicants shall notify the Corps if any listed species or critical habitat, or proposed species or critical habitat, is in the vicinity of the project and shall not begin work until notified by the District Engineer (DE) that the requirements of the ESA have been satisfied and that the activity is authorized. Information on the location of threatened and endangered species and their critical habitat can be obtained from the U.S. FWS and NMFS (see Page 16 for addresses).

11. Essential Fish Habitat. As part of the PGP screening process, the Corps will coordinate with NMFS in accordance with the 1996 amendments to the Magnuson-Stevens Fishery Conservation and Management Act to protect and conserve the habitat of marine, estuarine and anadromous finfish, mollusks, and crustaceans. This habitat is termed “Essential Fish Habitat (EFH)”, and is broadly defined to include “those waters and substrate necessary to fish for spawning, breeding, feeding, or growth to maturity.” Applicants may be required to describe and identify potential impacts to EFH. Conservation recommendations made by NMFS will normally be included as a permit requirement by the Corps. For additional information, see the EFH regulations at 50 CFR Part 600 (<http://www.nmfs.noaa.gov>). Additional information on the location of EFH can be obtained from NMFS (see Page 16 for contact information).

Any work in any aquatic habitat in the following rivers and streams, including all tributaries to the extent that they are currently or were historically accessible for salmon migration, shall not be authorized under Category 1 of the PGP and must be screened for potential impacts to EFH.

Androscoggin River	Hobart Stream	Passagassawaukeag River	Saco River
Aroostook River	Kennebec River	Patten Stream	Sheepscot River
Boyden River	Machias River	Penobscot River	St. Croix River
Dennys River	Narraguagus River	Pleasant River	Tunk Stream
Ducktrap River	Orland River	Presumpscot River	Union River
East Machias River			

12. Wild and Scenic Rivers. Any activity that occurs in a component of, or within 0.25 mile up or downstream of, the main stem or tributaries of a river segment of the National Wild and Scenic River System, must be reviewed by the Corps under the procedures of Category 2 of this PGP regardless of size of impact. This condition applies to both designated Wild and Scenic Rivers and rivers designated by Congress as study rivers for possible inclusion while such rivers are in an official study status. The Corps will consult with the National Park Service (NPS) with regard to potential impacts of the proposed work on the resource values of the Wild and Scenic River. The culmination of this coordination will be a determination by the NPS and the Corps that the work: (1) may proceed as proposed; (2) may proceed with recommended conditions; or (3) could pose a direct and adverse effect on the resource values of the river and an individual permit is required. If

preapplication consultation between the applicant and the NPS has occurred whereby NPS has made a determination that the proposed project is appropriate for authorization under this PGP (with respect to Wild and Scenic River issues), this determination should be furnished to the Corps with submission of the application. (See NPS address on Page 16.) National Wild and Scenic Rivers System segments for Maine as of September 2005 include: Allagash River beginning at Telos Dam continuing to Allagash checkpoint at Eliza Hole Rapids, approximately 3 miles upstream of the confluence with the St. John River (length = 92 miles).

13. Federal Navigation Project. Any structure or work that extends closer to the horizontal limits of any Corps Federal Navigation Project (See Appendix B) than a distance of three times the project's authorized depth shall be subject to removal at the owner's expense prior to any future Corps dredging or the performance of periodic hydrographic surveys.

14. Navigation. (a) There shall be no unreasonable interference with navigation by the existence or use of the activity authorized herein and no attempt shall be made by the permittee to prevent the full and free use by the public of all navigable waters at or adjacent to the activity authorized herein. (b) The permittee understands and agrees that, if future operations by the United States require the removal, relocation, or other alteration, of the structure or work herein authorized, or if, in the opinion of the Secretary of the Army or his authorized representative, said structure or work shall cause unreasonable obstruction to the free navigation of the navigable waters, the permittee will be required, upon due notice from the Corps of Engineers, to remove, relocate, or alter the structural work or obstructions caused thereby, without expense to the United States. No claim shall be made against the United States on account of any such removal or alteration.

15. Federal Liability. In issuing this permit, the Federal Government does not assume any liability for the following: (a) damages to the permitted project or uses thereof as a result of other permitted or unpermitted activities or from natural causes; (b) damages to the permitted project or uses thereof as a result of current or future activities undertaken by or on behalf of the United States (U.S.) in the public interest; (c) damages to persons, property, or to other permitted or unpermitted activities or structures caused by the activity authorized by this permit; (d) design or construction deficiencies associated with the permitted work; (e) damage claims associated with any future modification, suspension, or revocation of this permit.

Minimization of Environmental Impacts

16. Minimization. Discharges of dredged or fill material into waters of the United States, including wetlands, shall be avoided and minimized to the maximum extent practicable. Permittees may only fill those jurisdictional wetlands that the Corps authorizes to be filled and impact those wetlands that the Corps authorizes as secondary impacts. For coastal structures such as piers and docks, the height above the marsh at all points should be equal to or exceed the width of the deck. The height shall be measured from the marsh substrate to the bottom of the longitudinal support beam. This will help ensure sunlight reaches the area beneath the structure.

17. Heavy Equipment in Wetlands. Heavy equipment, other than fixed equipment (drill rigs, fixed cranes, etc.), working within wetlands shall not be stored, maintained or repaired in wetlands unless it is less environmentally damaging otherwise, and as much as possible shall not be operated there. Where construction requires heavy equipment operation in wetlands, the equipment shall

either have low ground pressure (<3 psi), or shall not be located directly on wetland soils and vegetation; it shall be placed on swamp or timber mats that are adequate to support the equipment in such a way as to minimize disturbance of wetland soil and vegetation. (See General Condition 18 below.) Other support structures that are less impacting and are capable of safely supporting equipment may be used with written Corps authorization. Similarly, not using mats during frozen, dry or other conditions may be allowed with written Corps authorization. An adequate supply of spill containment equipment shall be maintained on site.

NOTE: "Swamp mats" is a generic term used to describe structures that distribute equipment weight to prevent wetland damage while facilitating passage and providing work platforms for workers and equipment. They are comprised of sheets or mats made from a variety of materials in various sizes, and they include large timbers bolted or cabled together (timber mats). Corduroy roads, which are not considered to be swamp mats, are cut trees and/or saplings with the crowns and branches removed, and the trunks lined up next to one another.

18. Temporary Fill. Fill placed into waters of the U.S. (including wetlands) totaling greater than or equal to 4,300 SF (15,000 SF if a DEP Tier One Permit is issued) in total area (i.e., the sum of permanent and temporary fill areas) exceeds the Category 1 threshold and may not be discharged without written authorization from the Corps. When temporary fill is used (e.g., access roads, swamp mats, cofferdams), it shall be stabilized and maintained during construction in such a way as to prevent soil eroding into portions of waters of the U.S. where it is not authorized. Swamp or timber mats (see Gen.Cond. 17 above) are considered as temporary fill when they are removed immediately upon work completion. The area must be restored in accordance with Gen.Cond. 19.

- Unconfined temporary fill authorized for discharge into flowing water (rivers and streams) shall consist only of clean washed stone.
- Temporary fill authorized for discharge into wetlands shall be placed on geotextile fabric laid on the pre-construction wetland grade. (Swamp and timber mats are excluded from this requirement.)
- Temporary fill shall be removed as soon as it is no longer needed, and it shall be disposed of at an upland site and suitably contained to prevent subsequent erosion into waters of the U.S.
- Waters of the U.S. where temporary fill was discharged shall be restored (see Gen.Cond. 19).
- No temporary work shall drain a water of the U.S. by providing a conduit for water on or below the surface.

19. Restoration.

- Upon completion of construction, all disturbed wetland areas (the disturbance of these areas must be authorized) shall be stabilized with a wetland seed mix containing only plant species native to New England.
- The introduction or spread of invasive plant species in disturbed areas shall be controlled.
- In areas of authorized temporary disturbance, if trees are cut they shall be cut at ground level and not uprooted in order to prevent disruption to the wetland soil structure and to allow stump sprouts to revegetate the work area, unless otherwise authorized.
- Wetland areas where permanent disturbance is not authorized shall be restored to their original condition and elevation, which under no circumstances shall be higher than the pre-construction elevation. Original condition means careful protection and/or removal of existing soil and vegetation, and replacement back to the original location such that the original soil layering and vegetation schemes are approximately the same, unless otherwise authorized.

20. Coastal Bank Stabilization. Projects involving construction or reconstruction/maintenance of bank stabilization structures within Corps jurisdiction should be designed to minimize environmental effects, effects to neighboring properties, scour, etc. to the maximum extent practicable. For example, vertical bulkheads should only be used in situations where reflected wave energy can be tolerated. This generally eliminates bodies of water where the reflected wave energy may interfere with or impact on harbors, marinas, or other developed shore areas. A revetment is sloped and is typically employed to absorb the direct impact of waves more effectively than a vertical seawall. It typically has a less adverse effect on the beach in front of it, abutting properties and wildlife. For more information, see the Corps Coastal Engineering Manual (supersedes the Shore Protection Manual), located at <http://chl.erdc.usace.army.mil>. Select "Products/ Services," "Publications." Part 5, Chapter 7-8, a(2)c is particularly relevant.

21. Sedimentation and Erosion Control. Adequate sedimentation and erosion control management measures, practices and devices, such as phased construction, vegetated filter strips, geotextile silt fences, hay bales or other devices, shall be installed and properly maintained to reduce erosion and retain sediment on-site during and after construction. They shall be capable of preventing erosion, of collecting sediment, suspended and floating materials, and of filtering fine sediment. These devices must be removed in a timely manner upon completion of work, but not until the disturbed areas have been stabilized. The sediment collected by these devices shall be removed and placed at an upland location in a manner that will prevent its later erosion into a waterway or wetland. All exposed soil and other fills shall be permanently stabilized at the earliest practicable date.

22. Waterway Crossings.

(a) All temporary and permanent crossings of waterbodies (waterways and wetlands) shall be suitably culverted, bridged, or otherwise designed to withstand and to prevent the restriction of high flows, to maintain existing low flows, and to not obstruct the movement of aquatic life indigenous to the waterbody beyond the actual duration of construction. (NOTE: Areas of fill and/or cofferdams must be included in total waterway/wetlands impacts to determine applicability of this PGP).

(b) Aquatic Life Movements. No activity may substantially disrupt the necessary life-cycle movements of those species of aquatic life indigenous to the waterbody, including those species that normally migrate through the area, unless the activity's primary purpose is to impound water. For new permanent crossings, open bottom arches, bridge spans or embedded culverts are generally preferred over traditional culverts and should be installed when practicable. Coordination with the Corps is recommended for Category 1 projects when site constraints (e.g., placing footings) may render open bottom arches, bridge spans or embedded culverts impractical. In these cases, well-designed culverts may actually perform better. Culverts shall be installed with their inverts embedded below existing streambed grade to avoid "hanging" and associated impediments to fish passage. The "Design of Road Culverts for Fish Passage" provides design guidance and is available at www.nae.usace.army.mil, "Regulatory/Permitting," "Other."

(c) Culverts at waterbody crossings shall be installed in such a manner as to preserve hydraulic connectivity, at its present level, between the wetlands on either side of the road. The permittee shall take necessary measures to correct wetland damage due to lack of hydraulic connectivity.

(d) Culverts and bridges shall span the waterway a minimum of 1.2 times the bankfull width in probable fish bearing waterways to qualify as a Category 1 non-reporting activity. See "Design of Road Culverts for Fish Passage," referenced in (b) above, for information on bankfull width.

(e) Projects using slip lining (retrofitting an existing culvert by inserting a smaller diameter pipe), plastic pipes, and High Density Polyethylene Pipes (HDPP) are not allowed as non-reporting Category 1 activities, either as new work or maintenance activities.

(f) Waterbody crossings shall be culverted to at least municipal or State standards. The Maine DEP's stream crossing standards are at 06-096, Chapter 305: Permit by Rule, Section 10. Stream crossings (bridges, culverts and fords).

(g) Waterway crossings proposed by the Maine Dept. of Transportation should conform to the MDOT Fish Passage Policy and Design Guides.

(h) Construction equipment shall not cross streams without the use of temporary bridges, culverts, or cofferdams.

(i) For projects that otherwise meet the terms of Category 1, in-stream construction work shall be conducted during the low flow period July 15 - October 1 in any year. Projects that are not to be conducted during that time period are ineligible for Category 1 and shall be screened pursuant to Category 2, regardless of the waterway and wetland fill and/or impact area.

23. Discharge of Pollutants. All activities involving any discharge of pollutants into waters of the U.S. authorized under this PGP shall be consistent with applicable water quality standards, effluent limitations, standards of performance, prohibitions, and pretreatment standards and management practices established pursuant to the CWA (33 USC 1251) and applicable State and local laws. If applicable water quality standards, limitations, etc., are revised or modified during the term of this PGP, the authorized work shall be modified to conform with these standards within six months of the effective date of such revision or modification, or within a longer period of time deemed reasonable by the District Engineer in consultation with the Regional Administrator of the EPA. Applicants may presume that State water quality standards are met with the issuance of a LURC or DEP NRPA permit.

24. Spawning Areas. Discharges of dredged or fill material, and/or suspended sediment producing activities in fish and shellfish spawning or nursery areas and amphibian and waterfowl breeding areas during spawning or breeding seasons shall be avoided. During all times of year, impacts to these areas shall be avoided or minimized to the maximum extent practicable.

25. Storage of Seasonal Structures. Coastal structures, such as pier sections and floats, that are removed from the waterway for a portion of the year (often referred to as seasonal structures) shall be stored in an upland location located above mean high water (MHW) and not in tidal wetlands. These seasonal structures may be stored on the fixed, pile-supported portion of the structure that is seaward of MHW. This is intended to prevent structures from being stored on the marsh substrate and the substrate seaward of MHW. Seasonal storage of structures in navigable waters, e.g., in a protected cove on a mooring, requires Corps and local harbormaster approval.

26. Environmental Functions and Values. The permittee shall make every reasonable effort to carry out the construction or operation of the work authorized herein in a manner so as to maintain as much as is practicable, and minimize any adverse impacts on existing fish, wildlife, and natural environmental functions and values.

27. Protection of Vernal Pools. Impacts to uplands in proximity (within 500 feet) to the vernal pools referenced in Appendix A - Definitions of Categories, shall be minimized to the maximum extent possible.

Procedural Conditions

28. Cranberry Development Projects. For cranberry development projects authorized under the PGP, the following conditions apply:

- If a cranberry bog is abandoned for any reason, the area must be allowed to revert to natural wetlands unless an Individual Permit is obtained from the Corps allowing the discharge of fill for an alternate use.
- No stream diversion shall be allowed under this permit.
- No impoundment of perennial streams shall be allowed under this permit.
- The project shall be designed and constructed to not cause flood damage on adjacent properties.

29. Inspections. The permittee shall allow the District Engineer (DE) or his authorized representative(s) to make periodic inspections at any time deemed necessary in order to ensure that the work is being performed in accordance with the terms and conditions of this permit. The DE may also require post-construction engineering drawings for completed work and post-dredging survey drawings for any dredging work.

30. Work Start Notification Form and Compliance Certification. Every permittee who receives a written Category 1 or 2 PGP authorization from the Corps must submit a 1) Work Start Notification Form (WSNF) two weeks before work commencement, and 2) signed Compliance Certification Form within one month following the completion of the authorized work and any required mitigation (but not mitigation monitoring, which requires separate submittals). The Corps will forward the blank WSNF and Compliance Certification Form with the authorization letter. The Compliance Certification Form will include: (a) a statement that the authorized work was done in accordance with the Corps authorization, including any general or specific conditions; (b) a statement that any required mitigation was completed in accordance with the permit conditions; and (c) the signature of the permittee certifying the completion of the work and mitigation.

31. Maintenance. The permittee shall maintain the work or structures authorized herein in good condition and in conformance with the terms and conditions of this permit. This does not include maintenance of dredging projects. Maintenance dredging is subject to the review thresholds in Appendix A and/or any conditions included in a written Corps authorization. Maintenance dredging includes only those areas and depths previously authorized and dredged. Some maintenance activities may not be subject to regulation under Section 404 in accordance with 33 CFR 323.4(a)(2).

32. Property Rights. This permit does not convey any property rights, either in real estate or material, or any exclusive privileges, nor does it authorize any injury to property or invasion of rights or any infringement of Federal, State, or local laws or regulations. If property associated with work authorized by the PGP is sold, the PGP authorization is automatically transferred to the new property owner. The new property owner should provide this information to the Corps in writing. No acknowledgement from the Corps is necessary.

33. Modification, Suspension, and Revocation. This permit may be either modified, suspended, or revoked, in whole or in part, pursuant to the policies and procedures of 33 CFR 325.7. Any such action shall not be the basis for any claim for damages against the United States.

34. Restoration. The permittee, upon receipt of a notice of revocation of authorization under this permit, shall restore the wetland or waterway to its former condition without expense to the United States and as directed by the Secretary of the Army or his authorized representative. If the permittee fails to comply with such a directive, the Secretary or his designee may restore the wetland or waterway to its former condition, by contract or otherwise, and recover the cost from the permittee.

35. Special Conditions. The Corps, independently or at the request of the Federal resource agencies, may impose other special conditions on a project authorized pursuant to this general permit that are determined necessary to minimize adverse environmental effects or based on any other factor of the public interest. Failure to comply with all conditions of the authorization, including special conditions, will constitute a permit violation and may subject the permittee to criminal, civil, or administrative penalties or restoration.

36. False or Incomplete Information. If the Corps makes a determination regarding the eligibility of a project under this permit and subsequently discovers that it has relied on false, incomplete, or inaccurate information provided by the permittee, the permit shall not be valid and the government may institute appropriate legal proceedings.

37. Abandonment. If the permittee decides to abandon the activity authorized under this general permit, unless such abandonment is merely the transfer of property to a third party, he/she must restore the area to the satisfaction of the District Engineer.

Duration of Authorization/Grandfathering:

38. Duration of Authorization. This PGP expires five years from the effective date listed at the top of Page 1. Activities authorized under Category 1 of this PGP that have commenced (i.e., are under construction) or are under contract to commence in reliance upon this PGP's authorization will remain authorized provided the activity is completed within 12 months of the PGP's expiration date. Activities authorized under Category 2 of this PGP will remain authorized in accordance with the project-specific date that the Corps provides to the permittee in the PGP authorization letter, unless:

- (a) The PGP is either modified or revoked, or
- (b) Discretionary authority has been exercised on a case-by-case basis to modify, suspend, or revoke the authorization in accordance with 33 CFR 325.2 (e)(2).

39. Previously Authorized Activities.

- (a) Activities completed under the authorizations of past PGPs that were in effect at the time the activity was completed will continue to be authorized by those PGPs.
- (b) Completed projects that have received written verification or approval from the Corps, based on applications made to the Corps prior to issuance of this PGP or the previous nationwide permits, regional general permits, or letters of permission shall remain authorized as specified in each authorization.
- (c) Activities authorized pursuant to 33 CFR Part 330.3 ("Activities occurring before certain dates") are not affected by this PGP.

VI. CONTACTS FOR MAINE PROGRAMMATIC GENERAL PERMIT:

1. FEDERAL

U.S. Army Corps of Engineers

Maine Project Office
675 Western Avenue #3
Manchester, Maine 04351
(207) 623-8367
(207) 623-8206 (fax)

Federal Endangered Species

U.S. Fish and Wildlife Service
Maine Field Office
1168 Main Street
Old Town, Maine 04468
(207) 827-5938
207-827-6099 (fax)

Wild and Scenic Rivers

National Park Service
North Atlantic Region
15 State Street
Boston, Massachusetts 02109
(617) 223-5203

Federal Endangered Species & Essential Fish Habitat

National Marine Fisheries Service
One Blackburn Drive
Gloucester, Massachusetts 01939
(978) 281-9102
(978) 281-9301 (fax)

Bridge Permits

Commander (obr)
First Coast Guard District
One South Street - Battery Bldg
New York, New York 10004
(212) 668-7021

2. STATE OF MAINE

Maine Department of Environmental Protection (For State Permits & Water Quality Certifications)

Division of Land Resource Regulation
Bureau of Land and Water Quality
17 State House Station
Augusta, Maine 04333
(207) 287-2111

Southern Maine Regional Office
312 Canco Road
Portland, Maine 04103
(201) 822-6300

Eastern Maine Regional Office
106 Hogan Road
Bangor, Maine 04401
(207) 941-4570

Northern Maine Regional Office
1235 Central Drive - Skyway Park
Presque Isle, Maine 04769
(207) 764-0477

Maine Land Use Regulation Commission (LURC) [call (800) 452-8711 for appropriate LURC office]

22 State House Station
Augusta, ME 04333-0022
(207) 287-2631
(207) 287-7439 (fax)

45 Radar Road
Ashland, ME 04732-3600
(207) 435-7963
(207) 435-7184 (fax)

Lakeview Drive
P.O. Box 1107
Greenville, ME 04441
(207) 695-2466
(207) 695-2380 (fax)

(For CZM Determinations)

State Planning Office
Coastal Program
184 State Street
State House Station 38
Augusta, Maine 04333
(207) 287-1009

(For Submerged Lands Leases)

Maine Department of Conservation
Bureau of Parks and Lands
22 State House Station
Augusta, Maine 04333
(207) 287-3061

191 Main Street
East Millinocket, ME 04430
(207) 746-2244
(207) 746-2243

(For Aquaculture Leases)

Maine Department of Marine Resources
P.O. Box 8
West Boothbay Harbor, Maine 04575
(207) 633-9500

3. HISTORIC PROPERTIES

Maine Historic Preservation Commission

State House Station 65
Augusta, Maine 04333-0065
(207) 287-2132
(207) 287-2335 (fax)

Aroostook Band of Micmacs

Attn: Mr. Williams Phillips, Chief
7 Northern Road
Presque Isle, Maine 04769
(207) 764-1972
(207) 764-7667 (fax)

Houlton Band of Maliseet Indians

Attn: Tribal Chief
88 Bell Road
Littleton, Maine 04730
(207) 532-4273, x215
(207) 532-2660 (fax)

Passamaquoddy Tribe of Indians

Pleasant Point Reservation
Attn: Tribal Council
P.O. Box 343
Perry, Maine 04667
(207) 853-2600
(207) 853-6039 (fax)

Passamaquoddy Tribe of Indians

Indian Township Reservation
Attn: Donald Soctomah, THPO
P.O. Box 301
Princeton, Maine 04668
(207) 796-2301
(207) 796-5256 (fax)

Penobscot Indian Nation

Indian Island Reservation
Attn: Ms. Bonnie Newsom, THPO
12 Wabanaki Way
Indian Island, Maine 04468
(207) 817-7471
(207) 817-7450 (fax)

4. ORGANIZATIONAL WEBSITES:

Army Corps of Engineers	www.nae.usace.army.mil (click "Regulatory/Permitting")
Corps of Engineers Headquarters	www.usace.army.mil (click "Services for the Public")
Environmental Protection Agency	www.epa.gov/owow/wetlands/
National Marine Fisheries Service	www.nmfs.noaa.gov
U.S. Fish and Wildlife Service	www.fws.gov
National Park Service	www.nps.gov/rivers/index.html
State of Maine	www.maine.gov
State of Maine -Aquaculture Guidelines	www.maine.gov/dmr/aquaculture/index.htm

for Christine Jeffrey _____ *10-11-05*
District Engineer Date

APPENDIX A: DEFINITION OF CATEGORIES

A. INLAND WATERS AND WETLANDS	Inland Waters and Wetlands: Waters that are regulated under Section 404 of the Clean Water Act, including rivers, streams, lakes, ponds and wetlands, and excluding Section 10 Navigable Waters of the U.S. The jurisdictional limits are the ordinary high water (OHW) mark in the absence of adjacent wetlands, beyond the OHW mark to the limit of adjacent wetlands when adjacent wetlands are present, and the wetland limit when only wetlands are present. For the purposes of this PGP, fill placed in the area between the mean high water (MHW) and the high tide line (HTL), and in the bordering and contiguous wetlands ¹ to tidal waters are reviewed in the Navigable Waters section. (See II. Navigable Waters on the next page.)			INDIVIDUAL PERMIT
<p>CATEGORY 1</p> <p><4,300 SF inland waterway and/or wetland fill and associated secondary impacts (e.g., areas drained, flooded, cleared or excavated). Fill area includes all temporary and permanent fill, and excavation discharges (except for incidental fallback). Swamp mats are considered as fill. [See General Condition (GC) 18.]</p> <p><u>Provided:</u></p> <ul style="list-style-type: none"> • In-stream (e.g., rivers, streams, brooks, etc.) work limited to Jul 15 - Oct 1 • In-stream work of up to 4,300 SF of fill below OHW in waterways not designated as EFH for Atlantic salmon (see GC 11, Page 9) and performed in accordance with Maine Permit By Rule standards or a LURC permit. • Waterway crossings shall comply with GC 22. • Projects covered by a DEP Tier One permit with no cumulative impacts >15,000 SF in inland wetlands from previous permits, unauthorized work, and/or other state permits. • Subdivision fill complies with GC 5, Single and Complete Projects (see Page 7). <p><u>This category excludes:</u></p> <ul style="list-style-type: none"> • Dams, dikes or activities involving water diversions.² • Non-State approved sediment releases/slucices from dams. • Open trench excavation in flowing waters (see GC 22, Page 12). <p>Maine PGP</p>	<p>CATEGORY 2</p> <p>4,300 SF to <3 acres inland waterway and/or wetland fill and associated secondary impacts (e.g., areas drained, flooded, cleared or excavated). Fill area includes all temporary and permanent fill, and excavation discharges (except for incidental fallback). Swamp mats filling any area ≥4,300 SF are reviewed in Category 2. (See GC 18, Page 11.)</p> <p><u>Includes:</u> In-stream work, including crossings (other than spanned crossing as described in Category 1) with any discharge of fill below ordinary high water in perennial waterways designated as EFH for Atlantic salmon. Time of year restrictions determined case-by-case.</p> <p>Projects with proactive restoration as a primary purpose with impacts of any area ≥4,300 SF. The Corps, in consultation with State & Federal agencies, must determine that net adverse effects are not more than minimal.</p> <p>Specific activities with impacts of any area ≥4,300 SF required to affect the containment, stabilization, or removal of hazardous or toxic waste materials that are performed, ordered, or sponsored by a government agency with established legal or regulatory authority. Wetlands must be restored in place.</p> <p>I</p>	<p>CATEGORY 2</p> <p>≥3 acres inland waterway and/or wetland fill and secondary impacts (e.g., areas drained, flooded, cleared or excavated). Fill area includes all temporary and permanent fill, and excavation discharges (except for incidental fallback).³</p> <p>EIS required by the Corps.</p> <p>In-stream work exceeding Category 2 limits.</p>		

October 11, 2005

CATEGORY 1	CATEGORY 2	INDIVIDUAL PERMIT
<p>CATEGORY 1</p> <ul style="list-style-type: none"> • Work in waters designated as EFH for Atlantic salmon (see GC 11, Page 9), unless the waterway is crossed with a span and footprints of the span abutments are outside ordinary high water with no more than 4,300 SF of associated wetland impact. • Work in Special Inland Waters or Wetlands³ (vernal pools). • Work in special aquatic sites (SAS)⁴ other than wetlands. • Work within ¼ mile of a Wild and Scenic River (see GC 12, Page 9). • Work on National Lands (see GC 9, Pg. 9). • Work affecting threatened or endangered species (see GC 10, Page 9) or EFH salmon migration (see GC 11, Page 9). 	<p>CATEGORY 2</p>	<p>INDIVIDUAL PERMIT</p>
<p>(b) BANK STABILIZATION PROJECTS</p> <p>Inland bank stabilization <100 FT long and <1 CY of fill per linear foot below OHW.</p> <p><u>Provided:</u></p> <ul style="list-style-type: none"> • In-stream work limited to Jul 15 - Oct 1. • No work in special inland waters & wetlands³ and SAS⁴. • No open trench excavation in flowing waters (see GC 22, Page 12). • No structures angled steeper than 3H:1V allowed. Only rough-faced stone or fiber roll revetments allowed. • No work affects threatened or endangered species (see GC 10, Page 9) or EFH (see GC 11, Page 9). 	<p>Inland bank stabilization ≥100 FT long and/or ≥1 CY of fill per linear foot, or any amount with fill in wetlands.</p>	<p>Replacement of non-serviceable fill, or repair/maintenance of serviceable fill, with expansion ≥1 acre.</p>
<p>(c) REPAIR AND MAINTENANCE OF AUTHORIZED FILLS</p> <p>Repair or maintenance of existing, currently serviceable, authorized fills with no substantial expansion or change in use. *Conditions of the original authorization apply, however minor deviations in fill design allowed.⁶</p>	<p>Replacement of non-serviceable fills, or repair/maintenance of serviceable fill, with expansion <3 acres, or with a change in use.</p>	<p>Replacement of non-serviceable fill, or repair/maintenance of serviceable fill, with expansion ≥1 acre.</p>

<p>II. NAVIGABLE WATERS</p> <p>Navigable Waters of the United States: Waters that are subject to the ebb and flow of the tide and Federally designated navigable rivers (the Penobscot River, Kennebec River, and Lake Umbagog) (Section 10 Rivers and Harbors Act of 1899). The jurisdictional limits are the mean high water (MHW) line in tidal waters and the ordinary high water (OHW) mark in non-tidal portions of the Federally designated navigable rivers. For the purposes of this PGP, fill placed in the area between the mean high water (MHW) and the high tide line (HTL), and in the bordering and contiguous wetlands¹ to tidal waters are also reviewed in this Navigable Waters section.</p>			
<p>CATEGORY 1</p>	<p>CATEGORY 2</p>	<p>INDIVIDUAL PERMIT</p>	
<p>(a) FILL</p> <p>Discharges of dredged or fill material incidental to the construction of bridges across navigable waters of the United States, including cofferdams, abutments, foundation seals, piers, and temporary construction and access fills provided the U.S. Coast Guard authorizes such discharges as part of the bridge permit. Causeways and approach fills are not included in this category and require Category 2 or Individual Permit authorization.</p>	<p><1 acre fill and/or secondary waterway impacts (e.g., areas drained, flooded or cleared). Fill includes temporary and permanent waterway fill.</p> <p>Temporary fill or excavation <1 acre in SAS⁴.</p> <p>Permanent fill or excavation <1,000 SF in SAS⁴.</p> <p>Permanent fill and/or excavation ≥1,000 SF in SAS⁵ when associated with a project with proactive restoration as a primary purpose. The Corps, in consultation with Federal & state agencies, must determine that net adverse effects are not more than minimal.</p> <p>Specific activities with impacts of any area required to affect the containment, stabilization, or removal of hazardous or toxic waste materials that are performed, ordered, or sponsored by a government agency with established legal or regulatory authority. Wetlands must be restored in place.</p>	<p>≥1 acre waterway fill and/or secondary waterways or wetland impacts (e.g., areas drained, flooded or cleared). Fill includes temporary and permanent waterway fill.</p> <p>Temporary fill or excavation ≥1 acre in SAS⁴.</p> <p>Permanent fill or excavation ≥1,000 SF in SAS⁴ other than as specified in Cat. 2</p> <p>EIS required by the Corps.</p>	
<p>(b) REPAIR AND MAINTENANCE WORK</p> <p>Repair or maintenance of existing, currently serviceable, authorized structure or fill with no substantial expansion or change in use. *Conditions of the original authorization apply. Must be rebuilt in same footprint, however minor deviations in structure design allowed⁶</p>	<p>Replacement of non-serviceable structures and fills or repair/maintenance of serviceable structures <1 acre, or with a change in use.</p>	<p>Replacement of non-serviceable structures and fills or repair/maintenance of serviceable structures or fill, with replacement or expansion ≥1 acre.</p>	

INDIVIDUAL PERMIT	CATEGORY 2	CATEGORY 1	
<p>Maintenance dredging and/or disposal (any amount) in or affecting a SAS⁴. See II(a) above for dredge disposal in wetlands or waters.</p> <p>New dredging $\geq 25,000$ CY, or any amount in or affecting SAS⁴.</p> <p>Beach nourishment associated with dredging when the primary purpose is not navigation (i.e., aggregate/sand mining) or the material is from an upland source.</p>	<p>Maintenance dredging $\geq 1,000$ CY, new dredging $< 25,000$ CY, or projects not meeting Category 1. Includes return water from upland contained disposal areas.</p> <p><u>Provided:</u></p> <ul style="list-style-type: none"> Disposal includes 1) upland, 2) beach nourishment (above MHW) of any area provided dredging's primary purpose is navigation or sand is from an upland source and Corps, in consultation w/Federal and State agencies, determines the net adverse effects are not more than minimal; and open water & confined aquatic disposal, if Corps, in consultation with Federal and State agencies, finds the material suitable. 	<p>Maintenance dredging for navigational purposes $< 1,000$ cy with upland disposal. Includes return water from upland contained disposal area.</p> <p><u>Provided:</u></p> <ul style="list-style-type: none"> Proper siltation controls are used. Dredging & disposal operation limited to November 1 - January 15. No impact to special aquatic sites⁴. No dredging in intertidal areas. No work affects threatened or endangered species (see GC 10, Page 9) or EFH salmon migration (see GC 11, Page 9). 	(c) DREDGING AND ASSOCIATED DISPOSAL
<p>Moorings within the horizontal limits¹⁰, or with moored vessels that extend, into the horizontal limits of a Federal Navigation Project (See App. B), except those in Federal Anchorages under Category I.</p> <p>Note: Federal Navigation Projects include both Federal Channels and Federal Anchorages.</p>	<p>Moorings associated with a boating facility⁷.</p> <p>Moorings that don't meet the terms in Category I and don't require an Individual Permit.</p> <p>Moorings located such that they, and/or vessels docked or moored at them, are within the buffer zone of the horizontal limits¹⁰ of a Corps Federal Channel. (See Appendix B.) The buffer zone is equal to three times the authorized depth of that channel.</p>	<p>Private, non-commercial, non-rental, single-boat moorings authorized by the local harbormaster.</p> <p><u>Provided:</u></p> <ul style="list-style-type: none"> Not associated with any boating facility⁷ Not located in a Federal Navigation Project other than a Federal Anchorage. Moorings in Federal Anchorage not associated with a boating facility⁷. No interference with navigation Not located in vegetated shallows⁸ Within 1/4 mile of the owner's residence or a public access point.⁹ <p>Minor relocation of previously authorized moorings and moored floats consistent with Harbormaster recommendations, provided it is also consistent with local regulations, is not located in vegetated shallows, and does not interfere with navigation.</p>	(d) MOORINGS

	CATEGORY 1	CATEGORY 2	INDIVIDUAL PERMIT
(e) STRUCTURES AND FLOATS	<p>Reconfiguration of existing authorized structures or floats.</p> <p><u>Provided:</u></p> <ul style="list-style-type: none"> Structures not positioned over vegetated shallows⁸ or salt marsh. Floats supported off substrate at low tide. No dredging, additional slips or expansion. No work affects threatened or endangered species (see GC 10, Page 9) or EFH salmon migration (see GC 11, Page 9). 	<p>Private structures or floats, including floatways/skidways, built to access waterway (seasonal and permanent)</p> <p>Expansions to existing boating facilities⁷.</p> <p>Compliance with the following is recommended, but not required:</p> <ul style="list-style-type: none"> Pile-supported structures <400 SF, with attached floats totaling ≤200 SF. Bottom anchored floats ≤200 SF. Structures are ≤4' wide and have at least a 1:1 height:width ratio¹¹. Floats supported above the substrate during all tides. Structures & floats not located within 25' of any vegetated shallows⁸. Moored vessels not positioned over SAS⁴. No structure located within 25' of the riparian property boundary. No structure extends across >25% of the waterway width at mean low water. Not located within the buffer zone of the horizontal limits¹⁰ of a Corps Federal Navigation Project (FNP) (See App. B). The buffer zone is equal to three times the authorized depth of that FNP. 	<p>Structures or floats, including floatways/skidways, located such that they and/or vessels docked or moored at them are within the horizontal limits of a Corps Federal Navigation Project (see App. B).</p> <p>Structures and floats associated with a new or previously unauthorized boating facility⁷.</p> <p>Note: Federal Navigation Projects include both Federal Channels and Federal Anchorages.</p>
(f) MISCELLANEOUS	<p>Temporary buoys, markers, floats, etc. for recreational use during specific events, provided they are removed within 30 days after use is discontinued.</p> <p>The placement of aids to navigation and regulatory markers which are approved by and installed in accordance with the requirements of the U.S. Coast Guard. (See 33 CFR part 66, Chapter I, subchapter C)."</p>	<p>Structures or work in or affecting tidal or navigable waters, that are not defined under any of the previous headings listed above. Includes, but is not limited to, utility lines, aerial transmission lines, pipelines, outfalls, boat ramps, floatways/skidways, bridges, tunnels and horizontal directional drilling activities seaward of the MHW line.</p>	<p>EIS required by the Corps.</p> <p>Shellfish/finfish (other than Atlantic salmon), or other aquaculture facilities with more than minimal individual and cumulative impacts to environmental resources or navigation. A 25' eelgrass set back is recommended.</p>

	<p>Oil spill clean-up temporary structures or fill. Fish/wildlife harvesting structures/fill (as defined by 33 CFR 330, App. A-4)</p> <p>Scientific measurement devices and survey activities such as exploratory drilling, surveying and sampling activities. Does not include oil and gas exploration and fill for roads or construction pads.</p> <p>Shellfish seeding (brushing the flats¹²) projects.</p> <p>Provided:</p> <ul style="list-style-type: none"> • No work in National Wildlife Refuges. • No work affects threatened or endangered species (see GC 10, Page 9) or EFH salmon migration (see GC 11, Page 9). 	<p>Shellfish/finfish (other than Atlantic salmon), or other aquaculture facilities with no more than minimal individual and cumulative impacts to environmental resources or navigation. A 25" eelgrass set back is recommended. Aquaculture guidelines are provided at: www.maine.gov/dmr/aquaculture/index.htm.</p>	<p>Aquaculture guidelines are provided at: www.maine.gov/dmr/aquaculture/index.htm.</p>
--	---	--	--

¹ **Bordering and Contiguous Wetlands:** A bordering wetland is immediately next to its adjacent waterbody and may lie at, or below, the ordinary highwater mark (MHW in navigable waters) of that waterbody and is directly influenced by its hydrologic regime. Contiguous wetlands extend landward from their adjacent waterbody to a point where a natural or manmade discontinuity exists. Contiguous wetlands include bordering wetlands as well as wetlands that are situated immediately above the ordinary highwater mark and above the normal hydrologic influence of their adjacent waterbody. Note, with respect to the Federally designated navigable rivers, the wetlands bordering and contiguous to the tidally influenced portions of those rivers are reviewed under "II. Navigable Waters."

² **Water Diversions:** Water diversions are activities such as bypass pumping or water withdrawals. Temporary flume pipes, culverts or cofferdams where normal flows are maintained within the stream boundary's confines aren't water diversions. "Normal flows" are defined as no change in flow from pre-project conditions.

³ **Special Inland Waters and Wetlands:** Vernal Pools - Temporary to permanent bodies of water occurring in shallow depressions that fill during the spring and fall and may dry during the summer. Vernal pools have no permanent or viable populations of predatory fish. Vernal pools provide the primary breeding habitat for wood frogs, spotted salamanders, blue-spotted salamanders, and fairy shrimp, and provide habitat for other wildlife including several endangered and threatened species.

⁴ **Special Aquatic Sites:** Includes wetlands and saltmarsh, mudflats, riffles and pools, and vegetated shallows.

⁵ **IP Required:** The greater the impacts, the more likely an Individual Permit will be required. The Corps will determine the need for compensatory mitigation on a case-by-case basis.

⁶ **Maintenance:** Minor deviations in the structure's configuration or filled area, including those due to changes in materials, construction techniques, or current construction codes or safety standards, which are necessary to make repair, rehabilitation, or replacement are permitted, provided the adverse environmental effects resulting from such repair, rehabilitation, or replacement are minimal. No seaward expansion for bulkheads or any other fill activity is considered Category I maintenance. Currently serviceable means useable as is or with some maintenance, but not so degraded as to essentially require reconstruction.

⁷ **Boating Facilities:** Facilities that provide, rent, or sell mooring space, such as marinas, yacht clubs, boat yards, town facilities, dockminiums, etc.

⁸ **Vegetated Shallows:** Subtidal areas that support rooted aquatic vegetation such as eelgrass

⁹ **Mooring Location:** Cannot be at a remote location to create a convenient transient anchorage.

¹⁰ **Horizontal Limits:** The outer edge of a Federal Navigation Project (FNP). Contact the Corps of Engineers for information on FNP's.

¹¹ **Structures:** The height of structures shall at all points be equal to or exceed the width of the deck. For the purpose of this definition, height shall be measured from the marsh substrate to the bottom of the longitudinal support beam.

¹² **Brushing the Flats:** The placement of tree boughs, wooden lath structure, or small-mesh fencing on mudflats to enhance recruitment of soft-shell clams (*Mya arenaria*).

Federal Navigation Projects in Maine

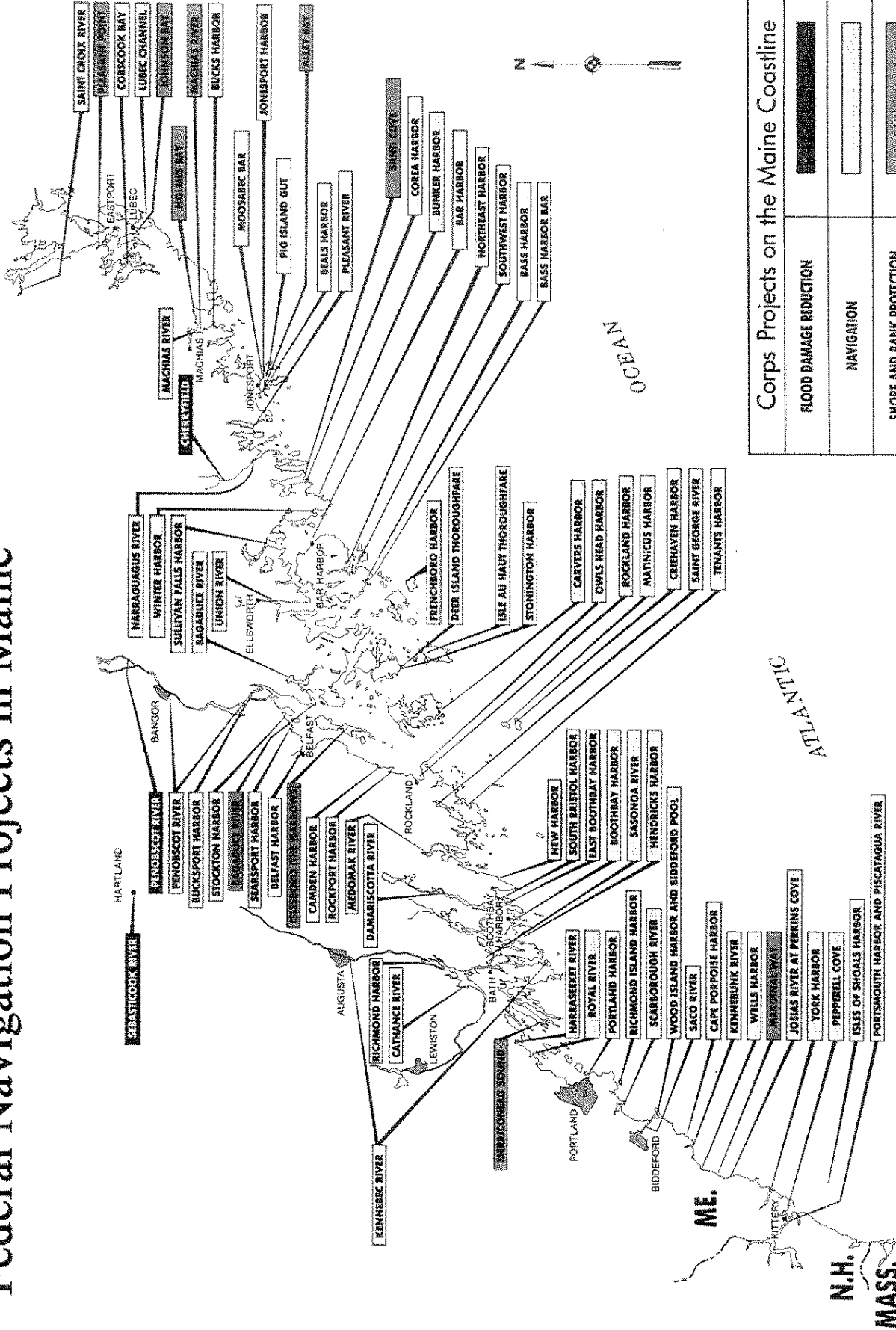

Corps Projects on the Maine Coastline	
FLOOD DAMAGE REDUCTION	
NAVIGATION	
SHORE AND BANK PROTECTION	

Town of Willimantic
 Earleys Bridge
 PIN # 017090.00
 June 2010

DEPARTMENT OF ENVIRONMENTAL PROTECTION
PERMIT BY RULE NOTIFICATION FORM

(For use with DEP Regulation, Chapter 305)

Town of Willimantic
 Earleys Bridge
 PIN #: 017090.00
 June 2010

PLEASE TYPE OR PRINT IN **BLACK INK ONLY**

Name of Applicant: (owner)	TOWN OF WILLIMANTIC	Name of Agent:	CALDERWOOD ENGINEERING, ETC		
Applicant Mailing Address:	PO Box 152	Agent Phone # (include area code):	(207)-737-2007		
Town/City:	WILLIMANTIC	PROJECT Information Name of Town/City:	CEE 44-BR-09 Earley's Bridge WILLIMANTIC		
State and Zip code:	MAINE, 04443	Name of Wetland or Waterbody:	BIG WILSON STREAM		
Daytime Phone # (include area code):	(207)-997-3615	Map #:	25	Lot #:	11 & 12
Detailed Directions to Site:	Travel 7mi North from Newport, ME along Rt. 11. Travel 8mi along Rt. 7 towards Dexter, ME. Go North 11 mi along Rt. 23 towards Guilford, ME. Go left onto Rt. 15 for 1mi. Turn Right onto Rt. 150 and travel 13mi towards Sebec Lake. Take a left off of Rt 150 towards Two Falls Camps and Airport Rd.				
	UTM Northing: (if known)		UTM Easting: (if known)		
Description of Project:	Temporary jacking of existing (3) steel girder bridge. Removal of existing wood abutments. Construction of (2) new steel reinforced concrete abutments.				
The expected area of impact is 140sf off the West bank, and 210sf off the East bank.					
Part of a larger project? (check one) →	<input type="checkbox"/> Yes <input checked="" type="checkbox"/> No	After the Fact? (check one) →	<input type="checkbox"/> Yes <input checked="" type="checkbox"/> No	Check one → This project <input checked="" type="checkbox"/> does (or) <input type="checkbox"/> does not involve work below mean low water (average low water).	

PERMIT BY RULE (PBR) SECTIONS: (Check at least one)

I am filing notice of my intent to carry out work which meets the requirements for Permit By Rule (PBR) under DEP Rules, Chapter 305. I and my agents, if any, **have read** and will comply with all of the standards in the Sections checked below.

- | | | |
|--|---|---|
| <input type="checkbox"/> Sec. (2) Act. Adj. to Protected Natural Res. | <input type="checkbox"/> Sec.(10) Stream Crossing | <input type="checkbox"/> Sec. (17) Transfers/Permit Extension |
| <input type="checkbox"/> Sec. (3) Intake Pipes | <input type="checkbox"/> Sec. (11) State Transportation Facil. | <input type="checkbox"/> Sec. (18) Maintenance Dredging |
| <input checked="" type="checkbox"/> Sec. (4) Replacement of Structures | <input type="checkbox"/> Sec. (12) Restoration of Natural Areas | <input type="checkbox"/> Sec. (19) Activities in/on/over significant vernal pool habitat |
| <input type="checkbox"/> Sec. (5) REPEALED | <input type="checkbox"/> Sec. (13) F&W Creation/Enhance/Water Quality Improvement | <input type="checkbox"/> Sec. (20) Activities in existing dev. areas located in/on/over high or moderate value inland waterfowl & wading bird habitat or shorebird nesting, feeding & staging areas |
| <input type="checkbox"/> Sec. (6) Movement of Rocks or Vegetation | <input type="checkbox"/> Sec. (14) REPEALED | |
| <input type="checkbox"/> Sec. (7) Outfall Pipes | <input type="checkbox"/> Sec. (15) Public Boat Ramps | |
| <input type="checkbox"/> Sec. (8) Shoreline stabilization | <input type="checkbox"/> Sec. (16) Coastal Sand Dune Projects | |
| <input type="checkbox"/> Sec. (9) Utility Crossing | | |

I have attached the following required submittals. **NOTIFICATION FORMS CANNOT BE ACCEPTED WITHOUT THE NECESSARY ATTACHMENTS:**

- Attach** a check for \$65 made payable to: "Treasurer, State of Maine".
- Attach** a U.S.G.S. topo map or Maine Atlas & Gazetteer map with the project site clearly marked.
- Attach Proof of Legal Name.** If applicant is **not** an individual or municipality, provide a copy of Secretary of State's registration information (available at <http://licrs.informe.org/hei-sos-licrs/ICRS?MainPage=x>)
- Attach photos of the proposed site where activity will take place as outlined in PBR Sections checked above.**
- Attach all other required submissions as outlined in the PBR Sections checked above.**

I authorize staff of the Departments of Environmental Protection, Inland Fisheries & Wildlife, and Marine Resources to access the project site for the purpose of determining compliance with the rules. I also understand that **this permit is not valid until approved by the Department or 14 days after receipt by the Department, whichever is less.**

By signing this Notification Form, I represent that the project meets all applicability requirements and standards in the rule and that the applicant has sufficient title, right, or interest in the property where the activity takes place.

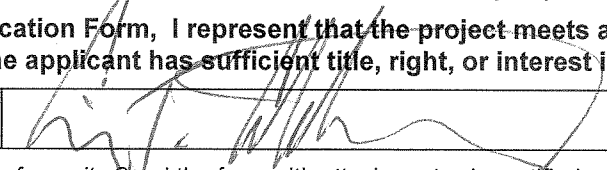
Signature of Agent or Applicant:		Date:	3/19/2010
----------------------------------	---	-------	-----------

Keep a copy as a record of permit. Send the form with attachments via certified mail or hand deliver to the Maine Dept. of Environmental Protection at the appropriate regional office listed below. The DEP will send a copy to the Town Office as evidence of the DEP's receipt of notification. No further authorization by DEP will be issued after receipt of notice. Permits are valid for two years. **Work carried out in violation of any standard is subject to enforcement action.**

- | | | | |
|--|---|---|---|
| AUGUSTA DEP
17 STATE HOUSE STATION
AUGUSTA, ME 04333-0017
(207)287-3901 | PORTLAND DEP
312 CANCO ROAD
PORTLAND, ME 04103
(207)822-6300 | BANGOR DEP
106 HOGAN ROAD
BANGOR, ME 04401
(207)941-4570 | PRESQUE ISLE DEP
1235 CENTRAL DRIVE
PRESQUE ISLE, ME 04769
(207)764-0477 |
|--|---|---|---|

OFFICE USE ONLY	CK.#	Date	Staff	Staff	After Photos 58
PBR #	FP		Acc. Date	Def. Date	

and not prohibited from sale under 38 M.R.S.A. 1682, provided it is cured on dry land in such a manner to expose all surfaces to the air for a period of at least 21 days prior to construction. Wood treated with creosote or pentachlorophenol may not be used where the wood will come in contact with water.

(16) Blasting in inundated areas is prohibited.

D. Definitions. The following terms, as used in this chapter, have the following meanings, unless the context indicates otherwise:

- (1) Land adjacent to a protected natural resource. Any land area within 75 feet, measured horizontally, of the normal high water line of a great pond, river, stream or brook or the upland edge of a coastal wetland or freshwater wetland.
- (2) Non-native wetland plants. Wetland grasses, forbs, shrubs, or trees not native to the State of Maine, for example, common reed (*Phragmites communis*) and purple loosestrife (*Lythrum salicaria*).

4. Replacement of structures

A. Applicability

- (1) This section applies to the replacement of an existing permanent structure in, on, or over a coastal wetland, freshwater wetland, great pond, fragile mountain area, or river, stream or brook. Some activities involving maintenance and repair of a permanent structure may not require a permit (see note 2 at the end of this section).
- (2) In order to be eligible for this section, the structure must have been in place and functioning as intended within 24 months of the DEP's receipt of the notification form. A permit by rule for replacement is valid for three years from the date of approval.
- (3) This section does not apply to the replacement of a structure adjacent to a protected natural resource. (See Section 2: Activities adjacent to protected natural resources.)
- (4) This section does not apply to structures located within a sand dune system. (See Section 16: Activities in coastal dune systems.)
- (5) This section does not apply to the replacement of a dam or a tidal flood gate.
- (6) This section does not apply to an activity that is not or will not be in compliance with the terms and conditions of permits issued under the Site Location of Development Law, 38 M.R.S.A. Sections 481 to 490, the Storm Water Management Law, 38 M.R.S.A. Section 420-D, or the Natural Resources Protection Act, 38 M.R.S.A. Sections 480-A to 480-Z.
- (7) This section does not apply to an activity that will not conform to the local shoreland zoning ordinance.

NOTE: Contact the local Code Enforcement Officer for information on local shoreland zoning requirements

B. Submissions

- (1) For an activity occurring in tidal waters, notice of approval of timing of the activity from the Department of Marine Resources must be submitted to the DEP with the notification form.
- (2) The applicant is required to submit photographs of the area which will be affected by the activity proposed.
- (3) Photographs showing the completed project and the affected area must be submitted within 20 days of the activity's completion. The photographs must be sent with a copy of the notification form or labeled with the applicant's name and the town in which the activity took place.
- (4) A scaled plan or drawing of the structure to be replaced that includes at a minimum the location, width, length and height of the existing structure.

It is not necessary to have the plan professionally prepared. However, it must be legible and drawn to a scale that provides a clear representation of distances and measurements on the plan.

C. Standards

- (1) A replaced structure that is located in, on, or over a protected natural resource may not exceed the dimensions, including height, of the previously existing structure, and may not extend any further into the water body or wetland, except that retaining walls may be reinforced with a facing material not exceeding 6 inch in width or may be replaced with riprap in accordance with Section 8 "Shoreline stabilization".

NOTE: Vegetation is the preferred method of erosion control near water bodies. Where the use of vegetation is not feasible, riprap is preferred over retaining walls because it dissipates wave action and is a more stable structure over the long term. The DEP encourages the replacement of retaining walls with riprap, unless the presence of large trees or structures makes its use impractical.

- (2) The following measures must be taken to prevent erosion of soil or fill material from disturbed areas into the protected resources:
 - (a) Staked hay bales or silt fence must be properly installed between the area of soil disturbance and the edge of the resource before the activity begins;
 - (b) Hay bales or silt fence barriers must be maintained until the disturbed area is permanently stabilized;
 - (c) Within 7 calendar days following the completion of any soil disturbance, and prior to any storm event, mulch must be spread on any exposed soils;
 - (d) All disturbed soils must be permanently stabilized; and
 - (e) Within 30 days of final stabilization of the site, any silt fence must be removed.

NOTE: For guidance on erosion and sedimentation controls, consult the Maine Erosion and Sediment Control BMPs, dated March 2003. This handbook and other references are available from the DEP.

- (3) Disturbance of wetland vegetation must be avoided if possible. If wetland vegetation must be disturbed during the activity, it must be reestablished immediately upon completion of the activity and must be maintained.
- (4) Non-native wetland plants may not be planted in disturbed areas.
- (5) Work done in a river, stream or brook must allow for fish passage and the maintenance of normal stream flows at all times of year and may not impound water.
- (6) No dredging may take place during the activity and no material may be removed from the affected natural resource except that rocks that were part of the original structure may be removed or reused.
- (7) Work below the high water line of a great pond, river, stream or brook must be done at low water, except as required for emergency flood control work. Measures, such as a silt boom or staked fencing, must be employed to reduce and isolate turbidity.
- (8) If the activity occurs within tidal waters, the activity must occur during the time period approved by the Department of Marine Resources.
- (9) If work is performed in a river, stream or brook that is less than three feet deep at the time of the activity and at the location of the activity, the applicant must provide for temporary diversion of flow to the opposite side of the channel while work is in progress.
 - (a) Diversion may be accomplished by placing sandbags, timbers, sheet steel, concrete blocks, 6+ mil polyethylene or geotextiles from the bank to midstream on the upstream side of the activity. No more than two-thirds (2/3) or 25 feet of stream width, whichever is less, may be diverted at one time.
 - (b) Any material used to divert water flow must be completely removed upon completion of the activity, and the stream substrate must be restored to its original condition.
 - (c) A pump may be operated, where necessary, for a temporary diversion. The pump outlet must be located and operated such that erosion or the discharge of sediment to the water is prevented.
- (10) Wheeled or tracked equipment may not be operated in the water. Equipment operating on the shore may reach into the water with a bucket or similar extension. Equipment may cross streams on rock, gravel or ledge bottom.
- (11) All wheeled or tracked equipment that must travel or work in a vegetated wetland area must travel and work on mats or platforms in order to protect wetland vegetation.
- (12) All debris or excavated material must be stockpiled either outside the wetland or on mats or platforms. Hay bales, silt fence or mulch must be used, where necessary, to prevent sedimentation. Any debris generated during the activity must be prevented from washing

downstream and must be removed from the wetland or water body. Disposal of debris must be in conformance with Maine Hazardous Waste, Septage and Solid Waste Management Act, 38 M.R.S.A. Section 1301 *et seq.*

- (13) Uncured concrete may not be placed directly into the water. Concrete must be pre-cast and cured at least three weeks before placing in the water, or where necessary, must be placed in forms and cured at least one week before the forms are removed. No washing of tools, forms, etc. may occur in or adjacent to the waterbody or wetland.
- (14) The use of untreated lumber is preferred. Lumber pressure treated with chromated copper arsenate (CCA) may be used only if necessary and only if use is allowed under federal law and not prohibited from sale under 38 M.R.S.A. 1682, and provided it is cured on dry land in such a manner as to expose all surfaces to the air for a period of at least 21 days prior to construction. Wood treated with creosote or pentachlorophenol may not be used where the wood will come in contact with water.
- (15) The replaced structure may not interfere with, or reduce the opportunity for, existing navigational and recreational uses of the site.

D. Definitions. The following terms, as used in this chapter, have the following meanings, unless the context indicates otherwise:

- (1) Dam. Any man-made artificial barrier, including appurtenant works, the site on which it is located and appurtenant rights of flowage and access, that impounds or diverts a river, stream or brook or great pond.
- (2) Dredge. To move or remove, by digging scooping or suctioning any sand, silt, mud, gravel, rock, or other material from the bottom of a water body or wetland surface.
- (3) Fill. a. (verb) To put into or upon, supply to, or allow to enter a water body or wetland any earth, rock, gravel, sand, silt, clay, peat, or debris; b. (noun) Material, other than structures, placed in or adjacent to a water body or wetland.
- (4) Land adjacent to a protected natural resource. Any land area within 75 feet, measured horizontally, of the normal high water line of a great pond, river, stream or brook or the upland edge of a coastal wetland or freshwater wetland.
- (5) Public works project. A federal, state or local government, or state-regulated utility project for public use or service including, but not limited to, highways, dams, bridges, utility lines, water lines, sewerage, and recreational facilities such as boat launch facilities.
- (6) Replacement. Any activity that results in more than 50% of a structure being restored or reconstructed whether above or below the normal high water line.
- (7) Retaining wall. A vertical or near vertical structure generally constructed of wood, concrete or rock or a combination of these materials and located at or below the normal high water line.

- (8) Riprap. Heavy, irregularly-shaped rocks that are fit into place, without mortar, on a slope. Square or rectangular rocks with flat faces, such as quarry stone or manufactured blocks, do not qualify as “irregularly-shaped”.
- (9) Structure. Anything built for the support, shelter or enclosure of persons, animals, goods or property of any kind, together with anything constructed or erected with a fixed location on or in the ground. Examples of structures include buildings, utility lines and roads.
- (10) Non-native wetland plants. Wetland grasses, forbs, shrubs, or trees not native to the State of Maine, for example, common reed (*Phragmites communis*) and purple loosestrife (*Lythrum salicaria*).

NOTES:

- (1) Section 480-Q(15-A) of the NRPA exempts the installation, removal or repair of a septic system from permitting requirements as of March 1, 1995, as long as the system complies with all requirements of the subsurface wastewater disposal rules adopted by the Department of Human Services under 22 M.R.S.A. Section 42, subsection 3.
- (2) Section 480-Q(2) of the NRPA exempts from permitting the maintenance and minor repair of structures in, on, over or adjacent to a protected natural resource and maintenance and minor repair of private crossings of a river, stream or brook provided:
 - (a) Erosion control measures are taken to prevent sedimentation of the water;
 - (b) The crossing does not block fish passage in the water course;
 - (c) There is not additional intrusion into the protected natural resources; and
 - (d) The dimensions of the repaired structure do not exceed the dimensions of the structure as it existed 24 months prior to the repair.

Section 480-Q(2) does not apply to the repair of more than 50% of a structure located in a coastal sand dune system; the repair of more than 50% of a dam, unless that repair has been approved by a representative of the United States Natural Resources Conservation Service; or the repair of more than 50% of any other structure, unless the municipality in which the proposed activity is located requires a permit for the activity through an ordinance adopted pursuant to the mandatory shoreland zoning laws and the application for a permit is approved by the municipality.

- (3) Section 480-Q(2-B) of the NRPA exempts from permitting the replacement of a floating dock with another floating dock if the dimensions of the replacement dock do not exceed those of the dock being replaced and the configuration of the replacement dock is the same as the dock being replaced.
 - (4) Section 480-Q(9) of the NRPA exempts from permitting emergency repair or normal maintenance and repair of existing public works which affect any protected natural resource. An activity which is exempt under this subsection shall employ erosion control measures to prevent sedimentation of any surface water, shall not block fish passage in any water course and shall not result in any additional intrusion of the public works into the protected natural resource. This exemption does to apply to any activity on an outstanding river segment as listed in section 480-P.
-

REQUEST FOR APPROVAL
OF TIMING OF ACTIVITY
(DIF&W)

This form is for use in obtaining approval from the Department of Inland Fisheries and Wildlife (DIF&W) for the timing of certain projects in accordance with Chapter 305 Permit by Rule Standards.

To be filled out by applicant: (Instructions are on the back of this form)

1. Applicant's name: TOWN OF WILLIMANTIC
Address: C/O CALDERWOOD ENGINEERING
222 RIVER ROAD
RYHAMOND ME 04357
telephone: (207) 737-2007
2. I plan to perform the following activity (please check the appropriate box):
 Sec. 9 Utility crossings (if performed between Oct. 2 and July 14)
 Sec. 10 Stream crossings (if performed between Oct. 2 and July 14)
 Sec. 15 Public boat ramps (any location)
 Sec. 16 Activities in coastal sand dunes (moving sand between April 1 and September 1)
3. Brief description of project: [please include the name of the stream or waterbody, if known]
REPLACEMENT OF BRIDGE ABUTMENTS FOR
EARLEY'S BRIDGE OVER WILSON STREAM IN
WILLIMANTIC, MAINE
4. I plan to perform this activity between the dates of 5/1/2010 and 8/14/2010
(start date) (end date)
5. I have included a map showing the location of my project.
*[Please note that if no location map is provided, no approval will be granted by DIF&W]
6. Send completed form to the appropriate regional office of the Department of Inland Fisheries and Wildlife. A map of the regions and the regional office addresses has been attached to this form.

For agency use only:

The Department has reviewed the proposed timing of the activity identified above and:

approves of the project's timing as proposed.
 requires that the project's timing be changed to occur between _____ and _____
(end date) (start date)

Tom O'Leary Fisheries Biologist 3/22/10
DIF&W representative Position Date

State of Maine



Department of the Secretary of State

I, the Secretary of State of Maine, certify that according to the provisions of the Constitution and Laws of the State of Maine, the Department of the Secretary of State is the legal custodian of the Great Seal of the State of Maine which is hereunto affixed and that the paper to which this is attached is a true copy from the records of this Department.

In testimony whereof, I have caused the Great Seal of the State of Maine to be hereunto affixed. Given under my hand at Augusta, Maine, this seventeenth day of March 2010.



MATTHEW DUNLAP

Secretary of State

Additional Addresses

Legal Name	Title	Name	Charter #	Status
CALDERWOOD ENGINEERING ETC., LLC	Registered Agent		20061788DC	GOOD STANDING
Home Office Address (of foreign entity)		Other Mailing Address		