

Chapter 8– Conveyance and Distribution Systems

Many of the water quality BMPs discussed in this manual rely on conveyance and distribution systems to adequately get the water to the BMP. Swales are excellent alternatives to conventional curb and gutter design for roadways and are generally less expensive to install, where road gradients and availability of land within or adjacent to the right-of-way allow.

IMPORTANT: Conveyance and distribution systems are used to divide flow into two or more parts; they do not provide any water quality treatment or quantity control and should be designed by someone familiar with hydraulics. This chapter discusses some of the more common conveyance and distribution systems including:

- Vegetated Swale
- Flow Splitter
- Level Spreader
- Permeable Road Base

8.1 - VEGETATED SWALE

Vegetated swales are broad shallow earthen channels where the combination of low velocities and vegetative cover promotes some settlement of particulates and some degree of treatment by infiltration. Check dams create small infiltration pools along the length of the swale, which are used to retard and temporarily impound runoff to induce infiltration and promote filtering and settling of nutrients and other pollutants.

Site Suitability: The proper siting of a swale can enhance the pollutant removal efficiency. Vegetated swales are most applicable in residential or institutional areas where the percentage of impervious cover is relatively small. Roadside swales become less feasible as the number of driveways requiring culverts for swale crossings increases.

- **Slopes:** Areas with steep slopes may limit the use of swales. In such areas, swales should parallel the contour, in effect becoming diversions. If the slopes are too steep, the construction of low velocity swale cross sections may involve excessive disturbance of existing grades to provide stable back slopes.
- **Flow Volume/Velocity:** Vegetated swales are most effective when the flow depth is shallow and the velocities are low.
- **Using Natural Swales:** Existing channels should only be used when they conform to the same design requirements of new systems. Existing ditches should be checked to ensure that they have adequate capacity and that their channels are stable. Gullied, natural channels should be avoided where they are impractical to stabilize.
- **Separation from Seasonal High Water Table & Bedrock:** The recommended depth to seasonal high groundwater or bedrock for a swale is a minimum of 3 feet.

Design and Construction: Swales should not be kept wet for long duration for effective removal of stormwater pollutants. Good management practices include the reduction of the peak rate of runoff and the volume of water. Effective erosion control practices will limit the pollutant loading to the waterway.

- **Soils:** Soils should be suitable or amended to establish a vigorous stand of vegetation. If dense vegetation cannot be maintained in the swale, its effectiveness will be severely reduced. Sites on A or B hydrologic group soils will be more effective for infiltration, although swales on other soils will still provide some treatment through sedimentation.
- **Equipment Access and Crossings:** If the swale or waterway must be crossed or maintained with large equipment, the width should be increased and flatter cross-section incorporated into the design. Large mowing equipment may require a significant increase in width over that needed for hydraulic capacity and freeboard. Easements of sufficient width to allow access by equipment (typically 15 feet minimum) must be provided on either side of the swale.
- **Flow Velocity:** The channel should be designed for low velocity flow. A velocity of 1 fps is the maximum design storm flow velocity recommended when vegetated swales are being designed as a BMP. Higher velocities might be permissible for channel stability, but could result in resuspension of settled particulates. The maximum allowable Q10 (10-yr frequency 24-h duration storm) velocity should be less than 3 fps.
- **Flow Depth:** Flow depths in the swales should be minimized to increase the amount of vegetative filtering and settling. A maximum design flow depth of 1 foot is suggested. This will generally result in wide, shallow channel designs.
- **Minimum Channel Dimensions:** The minimum width of the flat bottom of a trapezoidal channel shall be at least 3 times the channel depth. Non-trapezoidal channels should have similar depth to width relationships. Channel sideslopes shall not exceed 3 (horizontal):1 (vertical) for seeded or sodded slopes, or 2:1 for riprap slopes, although the channels may be parabolic or trapezoidal (Maryland, 1984). A V-shaped swale is not recommended.
- **Pipe Separation:** Provide a minimum of 2 feet of soil between the bottom of the swale and the top of an underdrain pipe.

- **Vegetation:** Vegetation for swale linings should be selected based on soils and hydrologic conditions at the site. Recommended grasses include Ky-31 tall fescue, reed canary grass, redtop, rough stalked blue grass, and mixtures thereof.
- **Check Dam Design:** Check dams will decrease flow velocity and increase infiltration and can be very useful on steep slopes or on slopes with loose soils. The details of check dams within a vegetate swale are shown on Figure 9.1.
 - **Channel Bottom:** The area just downstream of the check dam should be protected from scour with rock riprap or protective channel lining. The check dam may have a solid level surface integrated into it for added durability.
 - **Check Dam Construction:** Check dam heights are generally 6 to 12 inches, depending on channel slope and desired storage capacity. Check dams should be constructed of unerodable rock or rock-lined material and should be notched or ported to allow the flows in excess of their infiltrative capacity to be bypassed.
- **Construction Considerations:** Construct and stabilize the waterway in advance of any other channels or structure that will discharge into it. Divert all flow from the waterway during the establishment of vegetation.

Maintenance: The area should be inspected for failures following heavy rainfall and repaired as necessary for newly formed channels or gullies. Bare spots should be reseeded or resodded. Trash, leaves and/or accumulated sediments should be removed. Woody or other undesirable vegetation should be controlled. Check dam integrity should be checked.

- **Aeration:** The buffer strip may require periodic mechanical aeration (by rototilling or other) to restore infiltration capacity. This aeration must be done during a time when the area can be reseeded and mulched prior to any significant rainfall.
- **Mowing:** Grass should not be trimmed extremely short, as this will reduce the filtering effect of the swale (MPCA, 1989). The cut vegetation should be removed to prevent the decaying organic litter from adding pollutants to the discharge from the swale. Mowed height of the grass should be 2-4 inches taller than the maximum flow depth of the design water quality storm. A minimum mow height of 6 inches is generally recommended (Galli, 1993).
- **Erosion:** It is important to install erosion and sediment control measures to stabilize this area as soon as possible and retain any organic matter in the bottom of the trench.
- **Fertilization:** Routine fertilization and/or pesticide use is strongly discouraged. If complete re-seeding is necessary, half the original recommended rate of fertilizer should be applied with a full rate of seed.
- **Sediment Removal:** Level of sediment deposition in the channel should be monitored regularly, and removed from grassed channels before permanent damage is done to the grassed vegetation, or if infiltration times are longer than 12 hours. Sediment should be removed from a channel when it reduces the capacity of the channel.

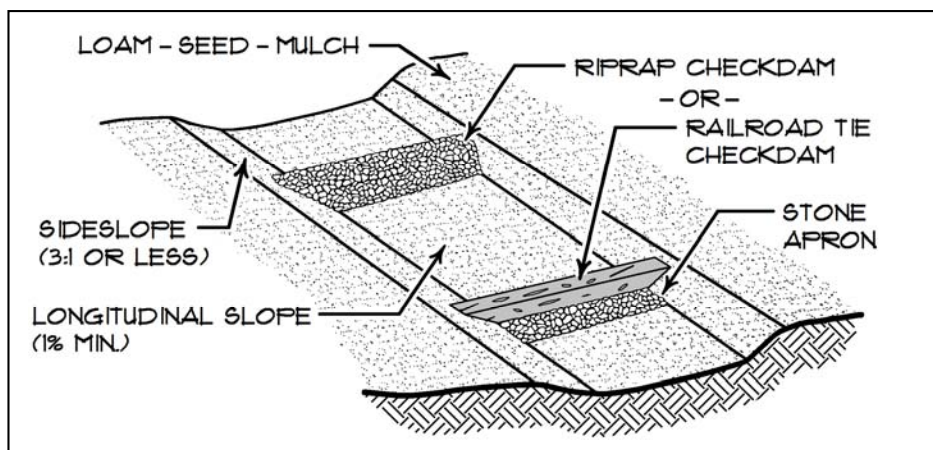

Figure 8.1
- Swale
with Check
Dams

8.2 - FLOW SPLITTER

A flow splitter is engineered to divide flows into two or more directions using devices such as pipes, orifices, and weirs set at specific elevations. Generally, a flow splitter will have a small storage area with one inlet and two outlets set at different elevations. The lower outlet conveys low flows, such as the flow during a small storm or the flow at the beginning of a large storm. The higher outlet conveys high flows that occur later in a larger storm.

- **Water Quality Treatment** - A flow splitter can separate the first flush volume which can contain most of the runoff pollutants; and provides it a longer treatment time in a treatment structure. Without a flow splitter, the first flush would be pushed out the outlet by the following runoff before the pollutants are removed.
- **Water Quantity Control** - A flow splitter can split the runoff to alleviate downstream flooding or it can also be used to prevent a BMP, such as a wet pond, from overtopping and eroding from excessive flows during large storms. This can reduce the needed storage capacity.

Design and Construction: Flow splitter design, to be effective, must be done by someone familiar with hydraulics. A badly-designed splitter can severely impede the function of the rest of the drainage system. The specific requirements for each design have to be determined on a case-by-case basis. Only basic criteria are given below and some examples are provided on Figure 9.2.

- **Elevations:** Precise setting of elevations and grades are crucial to its performance. The splitter should be set using accurate leveling techniques by a licensed surveyor. "Eyeing-in" a splitter is not acceptable.
- **Head Loss:** The flow splitter should be designed to minimize head loss by avoiding abrupt transitions in flows.
- **Flow Deflectors:** Flow deflectors provide a gradual transition for flow and should be included in most designs
- **Outlets:** The splitter must outlet to stable areas. Flow splitters built within drainage ditches may need armoring to withstand turbulent flows. The area of the flow splitter should be well-protected with riprap.
- **Access:** Because flow splitters involve a transition from larger pipes and channels to smaller pipes and channels, blockage is a problem. Debris that flows freely into the splitter may block the splitter's outlets and access is a necessity.

Maintenance: A flow splitter should be checked regularly and after every large storm to remove debris within the splitter.

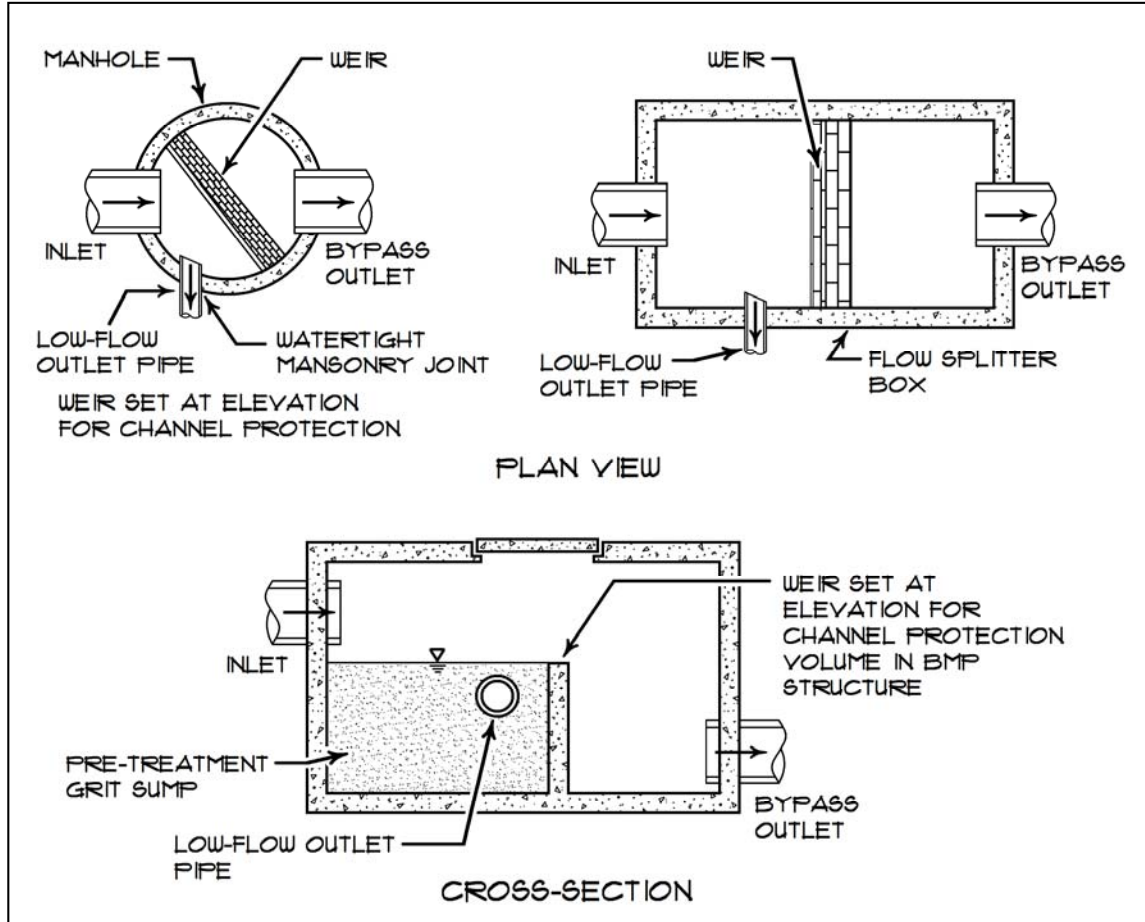

Figure 8.2 – Flow Splitter

8.3 - LEVEL SPREADERS

A level spreader is a vegetated or mechanical structure used to disperse or "spread" concentrated flow thinly over a receiving area to reduce erosion and movement of sediment, and also to filter sediment, soluble pollutants, and sediment-attached pollutants. The receiving area is generally a buffer or swale which needs a uniform distribution of flow to prevent channelization. The use of level spreaders with buffers should follow the design criteria in Chapter 5 of this manual.

Design and Construction: These standards are not applicable for level spreaders discharging runoff to buffers used to meet Chapter 500 General Standards. The drawing of a level spreader is shown on Figure 9.3.

- **Discharge to a Level Spreader:** The peak stormwater flow rate to a level spreader due to runoff from a 10-year, 24-hour storm should be less than 0.25 cubic feet per second (0.25 cfs) per foot length of level spreader lip. The maximum drainage area to the spreader should not exceed 0.10 acre per foot length of level spreader lip.
- **Buffer:** Each level spreader should have a vegetated receiving area with the capacity to pass the flow without erosion. The receiving area should be stable prior to the construction of the level spreader and its topography regular enough to prevent undue flow concentration before entering a stable watercourse. A receiving area that is unstable or lacking healthy vegetation, it should be re-established prior to construction of the level spreader and a discharge of water runoff. This will limit construction to the growing season.
- **Slope:** The slope of the receiving area below a level spreader should be less than 30%. If the slope is greater than 30%, the discharge will need to be brought by a conduit and velocity dissipator to an area that is suitable.
- **Receiving Area:** Level spreaders shall blend smoothly into the downstream receiving area without any sharp drops or irregularities to avoid channelization, turbulence and hydraulic jumps. The receiving area below the level spreader should be protected from harm during construction. A temporary diversion may be necessary until a reconstructed receiving area has been stabilized.
- **Soil Capacity:** The capacity of each level spreader should be based on the allowable velocity of the receiving soil. The flow area upstream of the level spreader shall be sufficient to ensure low approach velocities to the level "lip". The minimum flow area shall be equal to the flow area of the delivery channel.
- **Entrance Drainage Channel:** The entrance channel to a level spreader is constructed across the slope and consists of stone and existing natural vegetation to disperse, filter and lower the runoff velocity into the level spreader. The entrance channel should blend smoothly into the downstream receiving area without any sharp drops or irregularities to avoid turbulence and hydraulic jumps.
 - **Upstream Velocity:** The flow area upstream of the level spreader should be controlled to ensure low approach velocities to the level "lip." The minimum flow area of level spreader must equal to the flow area of the delivery channel.
 - **Shape:** The entrance channel is typically trapezoidal, but may be parabolic as long as the soil bed design width is equivalent to the design bottom width for a trapezoidal section and is no more than 2 feet deep. The channel should be constructed along the existing contour, be 15-20 feet long and at least 7 feet wide across the top.
 - **Length of Spreader:** The level spreader length should not be more than 25 feet unless the receiving area is appropriate to handle the additional flow.
 - **Bottom Width:** Bottom width for a trapezoidal cross section of the entrance channel should be a minimum of two feet.
 - **Side Slopes:** Side slopes of the entrance channel should be 2:1 or flatter to provide pretreatment of runoff entering the level spreader.
 - **Longitudinal Slope:** The longitudinal slope of the entrance channel should be 1% grade or less in order to avoid excessive velocity and deep ponding water at the

downstream end. If topography dictates a steeper net channel slope, the swale can be broken into relatively flat sections by check dams placed at no closer than 50 feet intervals.

- *Depth and Capacity:* The swale should be designed to safely convey the 2 year storm with design velocities less than 4.0 to 5.0 feet per second. The swale should have sufficient total depth to convey the 10-year storm with 6 inches of freeboard.
- *Berm:* The berm of the level lip should consist of ¾-3" crushed rock that will allow flows to slowly seep through the berm, and be a minimum of 18 inch high and 3 feet wide. The berm should have a 6 to 12 inch deep header channel with a 3-foot bottom width to trap sediments and reduce lateral flow velocities behind the berm. The bottom and back of the spreader channel should be lined with erosion control matting.
- *Access:* Level spreaders should be sited to provide easy access for removal of accumulated sediment and rehabilitation of the berm.
- *Installation:* A level spreader must be installed correctly with 0% grade on the spreader base and lip to ensure a uniform distribution of flow; otherwise the structure may fail and become a source of erosion.

Maintenance: Long term maintenance of the level spreader is essential to ensure its effectiveness. Spreaders constructed of wood, asphalt, stone or concrete curbing also require inspection and maintenance.

- *Inspections:* At least once a year and following major storms, the level spreader pool should be inspected for sand accumulation and debris that may reduce its capacity.
- *Sediment Removal:* Sediment build-up within the swale should be removed when it has accumulated to approximately 25% of design volume or channel capacity. Dispose of the sediments appropriately.
- *Debris:* Remove debris such as leaf litter, branches and tree growth from the spreader.
- *Mowing:* Vegetated spreaders may require mowing.
- *Snow Storage:* Do not store snow within the area of the level spreader.
- *Level Spreader Replacement:* The reconstruction of the level spreader may be necessary when sheet flow from the spreader channelize into the buffer.

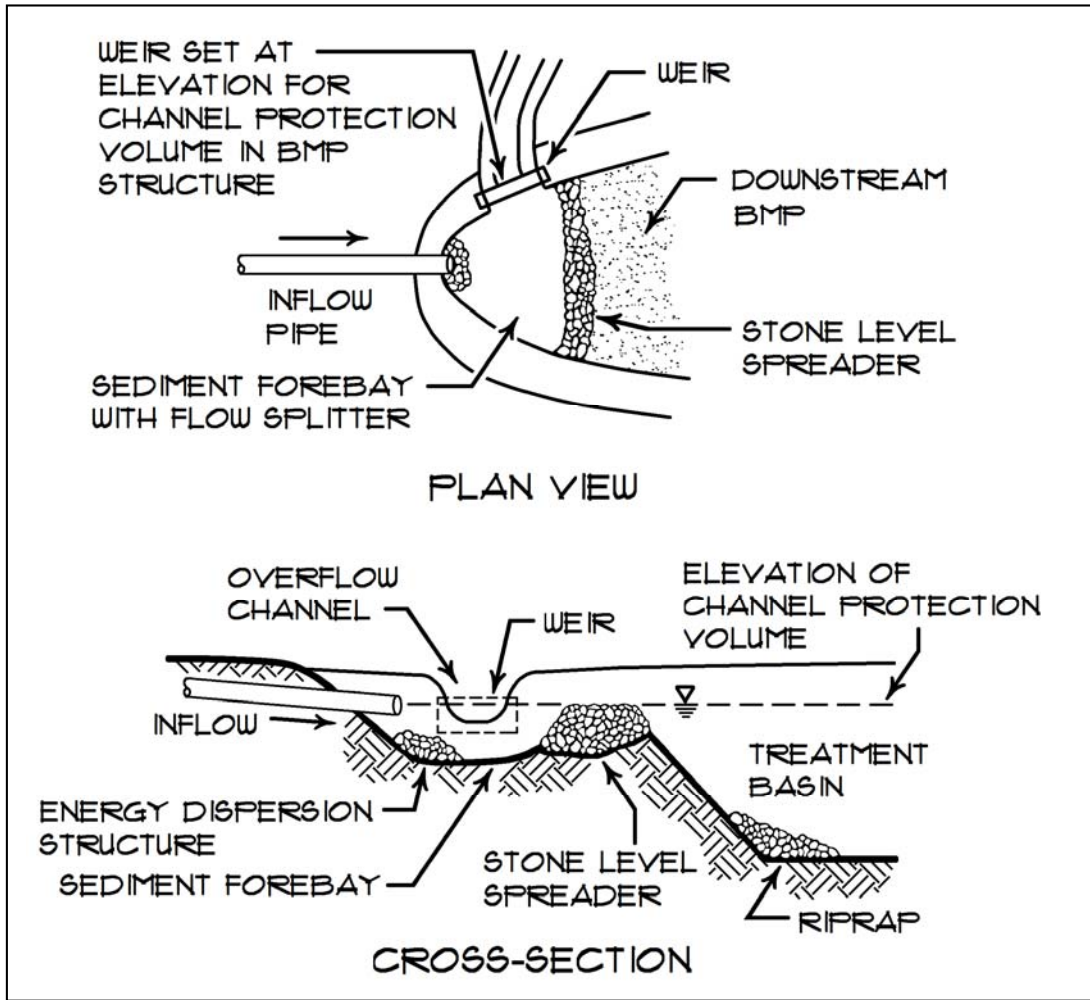

Figure 8.3 – Level Spreader Design

9.4 - PERMEABLE ROAD BASE

A rock sandwich is a specialized road base that consists of coarse rocks wrapped in fabric through which water can freely pass and be discharged downgradient of the road. It can convey surface water in wetlands, and cut and fill roads where the cut may intercept the groundwater table. It may be as narrow as a few feet in a perennial swale or over several hundred feet across a wetland. It is not intended for concentrated flows and unlike a culvert, a rock sandwich will not concentrate water to a single entry and exit point and will not channelize downgradient as the flow velocity is reduced through the rocks. It can be used in conjunction if the road cut is below seeping groundwater and the culvert provides flow relief for larger storm events. Groundwater has enough latent heat to prevent a rock sandwich from freezing. Note: a high seasonal groundwater table on a slope in granular soils is oxygenated so it is not considered a wetland.

As benefits, the rock sandwiches:

- Reconnect intercepted natural hydrology.
- Assist in the treatment of road runoff by a non-structural method avoiding the need for costly structural measures and their maintenance.
- Strengthen soft soil road bases significantly.
- Have a wide discharge area that does not concentrate flows and cause scour or erosion.
- Prevent groundwater from wicking up into the road fill material thereby reducing frost actions and potholing.

General Design Criteria: The rock sandwich consists of 3" – 6" stone "sandwiched" between layers of permeable filter fabric through which water can freely pass from one side of the road to the other as sheet flow. Both ends of the stone sandwich are exposed so that water can enter and pass through it unimpeded. A rock sandwich should be used in areas of:

- Non-concentrated flows: areas where concentrated flows from a pipe may be undesirable, impractical, or regulated.
- Road impoundment: In areas where a road is acting as an impoundment or dam to the natural water flow by isolating subsurface water on one side of the road from the other.
- Shallow bedrock depth: Areas where the depth of a pipe would not provide sufficient structural cover; could lower the natural water table of the area, and require long-term maintenance.
- Wetland crossing: Low-lying areas near streams or wetlands where maintaining sheet flow would be difficult.
- Road load bearing: A filter fabric and rock layer in the lower portion of a road provides bearing strength. The water collects in the voids provided by the larger rock and moves away by gravity rather than softening the subbase soils.

Specific Design Criteria: To minimize the alteration of wetlands, do not stump and grub wetland surfaces under the road footprint. Cut trees close the ground, leaving the stumps in place which will provide added structural support to the rock sandwich. This woody debris will not decompose as it will be anaerobic. The intact soil surface is less of a threat to move and plug up the rock sandwich material. In cut and fill roads, minimize ground disturbance and avoid excavating ditches. A drawing of a rock sandwich is shown on Figure 9.4.

- Bottom geotextile: After the site has been prepared, place a permeable woven/non-woven filter fabric over the length of roadway with a rock sandwich. Filter fabric "joints" should overlap by at least 18".
- Material: The core material of a rock sandwich is a minimum of 12" thick layer of clean 3"-6" diameter stone on the fabric for the full width of the roadway.

- **Top geotextile:** Place permeable, non-woven filter fabric on top of the entire length of rock layer. Do not cover the upgradient and downgradient sides of the rock layer with filter fabric or soil. Leave these areas exposed so that surface water from the upslope part of the wetland can pass unimpeded to the downslope part of the wetland.
- **Upgradient soil disturbance:** If inadvertent soil disturbance has occurred on the upslope side of the rock sandwich, place stone on the disturbed soil so that it will not migrate to the ends of the rock sandwich and plug it up.
- **Road fill and road base:** Place additional road fill as designed and the driving surface material over the top filter fabric according to specifications and procedures (minimum of 6" recommended after compaction).
- **Upgradient of cut slopes:** Place 3"-6" thick layer of rock sandwich stone on cut face up to the height of seeps. This allows for seepage to reach the rock sandwich in the roadbed but holds the soil in place.
- **Downgradient of fill slopes:** Do not cover the downslope edge of the rock sandwich stone with geotextile so that water can freely diffuse back into sheet flow and that the slope is protected.
- **Culverts in Rock Sandwich:** If the crossing has a stream, a defined drainageway or larger concentrated flows are anticipated, a culvert should be installed according to appropriate design standards. The culvert should be installed where its invert is at least 3" above the elevation of the bottom of the rock sandwich to assure that the rock sandwich passes base flows and the culvert is only used for high runoff flows.

Maintenance: Check upslope face of stone layer to prevent clogging by eroded soil, road sand, debris and leaf litter. Clean regularly.

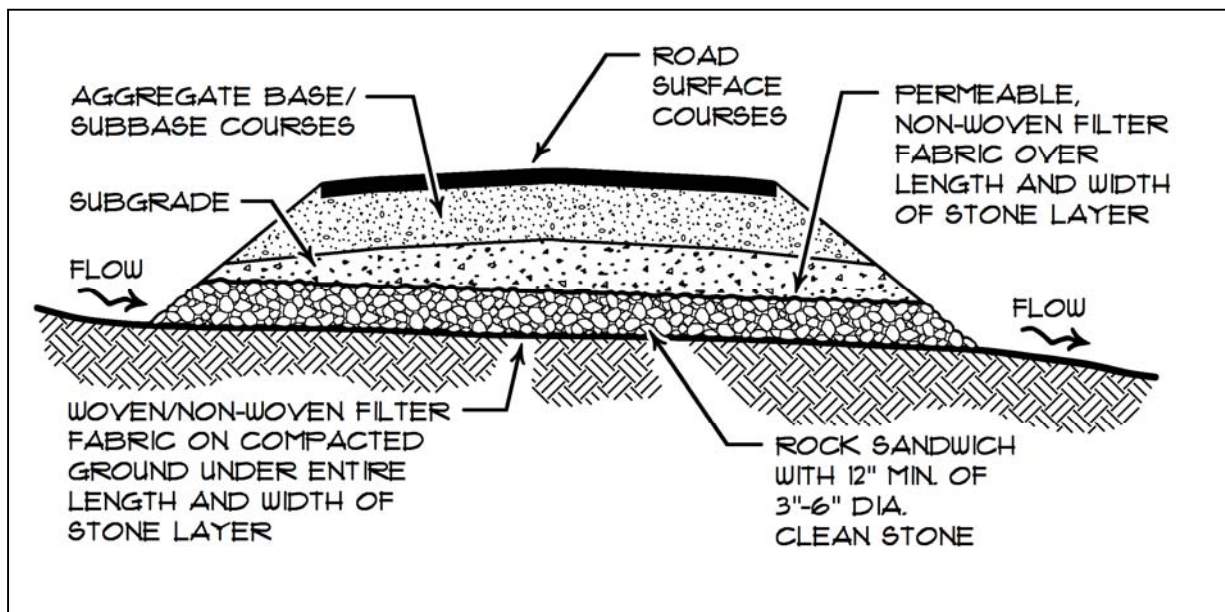

Figure 8.4 – Rock Sandwich Cross-Section