

March 30, 2016

Mr. Lou Pizzuti  
Maine Department of Environmental Protection  
Bureau of Remediation and Waste Management  
17 State House Station  
Augusta, Maine 04333-0017

**Re: Processing Facility Application DEP# S-022458-WK-A-N | Supplemental Information Response**

Dear Mr. Pizzuti:

On behalf of Fiberright, LLC (Fiberright) and the Municipal Review Committee (MRC), CES, Inc. (CES) is providing the following responses to your request for supplemental information in support of the previous submission dated March 8, 2016. Attachments with the requested revisions and supplemental information are as follows:

- ◆ Supplemental Wastewater Storage information – System description and location;
- ◆ Revised Responses to Lou Pizzuti/Victoria Eleftheriou letter dated February 3, 2016;
- ◆ Final Waste Agreement between MRC and Waste Disposal Management Services of Maine;
- ◆ Updated Mass Balance and Process Flow Diagram – Shows disposition of each stream of materials and a breakdown of those that are partially recovered;
- ◆ Updated Attachment 13, Process Design Information and the Operations and Maintenance Manual (O&M);
- ◆ Updated Site Plan (Sheet C101);
- ◆ Amended geotechnical report signature page; and
- ◆ General Arrangement Process Diagram – Revised to depict the location of residues and secondary materials.

Should you have any questions regarding the information provided, please feel free to contact us.

Sincerely,  
CES, Inc.



Kyle Sullivan  
Senior Project Scientist



Denis St. Peter, P.E.  
Principal / Senior Project Manager

KS/DSP/jok  
Attachments

Mr. Lou Pizzuti | 03.30.2016 | 11293.001 | Page 1

## WASTEWATER STORAGE DESCRIPTION

# MEMO

**To:** JN 11293.001 FILE

**From:** Travis Noyes, P.E.

**Re:** **Wastewater Storage Requirements – Fiberright Facility**

**Date:** March 30, 2016

---

As noted in the information provided by the City of Bangor, they have the capacity during dry weather conditions to accept the estimated average daily flow of 150,000 gallons per day. During a meeting with the City in December 2015, it was mentioned that storage or some other alternate means of handling wastewater would be required during wet weather conditions to alleviate issues with the City's Combined Sewer Overflows (CSOs). Given that discussions with the City are on-going, for purposes of this permit application, we have assumed the need to provide alternate means for handling wastewater during wet weather conditions for 300,000 gallons or two times the estimated average daily flow.

The operational team of the proposed facility will manage the discharge of wastewater during wet weather conditions with the use of on-site storage tanks. The tanks will consist of the following:

Use 50,000 gallon buffer in 150,000 gallon process water storage tank (internal to facility)

Install 150,000 gallon above ground sewer hold tank (external to facility)

Install 100,000 gallon below ground tank (external to facility)

Materials of construction for the tanks are still being evaluated and will be determined during final design.

The preliminary proposed location of the below ground tank has been selected to be beneath the employee parking area and the above ground external holding tank is located next to the parking area (as shown on the attached Site Plan C101). Wastewater would enter the tanks for storage during wet weather events and would be conveyed to the gravity sewer system serving the facility once the wet weather event was over.

The external below ground tank dimensions are anticipated to be approximately 40 feet long by 40 feet wide by 10 feet deep. If a circular tank is chosen, the dimensions would be approximately 45 feet in diameter and 10 feet in depth. The 150,000 gallon above ground storage tank is circular and is proposed to be located adjacent to the below ground tank. Again, as final design calculations are performed, the materials of construction and tank dimensions will be finalized.

Revised Responses

## Revised February 3, 2016 Letter Responses

### Attachment 13, Process Design Information

**Comment:**

- 3. The approximate timeframe to fill a residue storage container should be provided. The description for residue storage states that residues will not be stored on site for longer than 24 hours, then states a full container will be transferred within 24 hours.*

**Response:**

3. There are multiple containers that will be used to collect and dispose of plant residues. The residues as detailed in the mass balance summary includes: bulkies, textiles, and trash, and combined diffused air flotation (DAF) residues will either be routed directly and/or loaded into a staged dump or walking floor trailer. With the volumes of these materials being produced, it is expected that this trailer will be filled every 3-4 hours depending on the overall average density of the combined residue stream. The total grit and glass will be deposited into a 40 cubic yard container, of which one would be filled in 23-24 hours. The combined boiler ash will also be deposited into a separate 40 cubic yard container, of which one would be filled in 18-19 hours. Full residue containers will be shipped off-site for disposal as soon as possible but, at a maximum end of business the following day.

**Comment:**

- 4. Additional information regarding the ash handling system should be provided including whether bottom and fly ash will be combined or stored separately and provisions for dust control, if necessary.*

**Response:**

4. The system being utilized to collect boiler bottom ash and fly ash has been designed to minimize any air-borne dust. The Hurst boiler system includes two multi-cyclone collectors that capture the fly ash which is then routed to the wet ash conveyor where it is combined with the wet ash. This is done by a closed duct/conveying system to avoid any air-borne dust escaping. The dust collected in the baghouse is also sent to the wet ash conveyor in a similar manner using closed ash chutes/conveyors to allow it to mix with the wet ash stream. The final combined ash stream exiting the wet ash conveyor contains adequate moisture to eliminate any potential dust emissions and is conveyed to a staged container to be transferred for ultimate disposal. Full ash containers will be shipped off-site for disposal as soon as possible but, at a maximum by end of business the following day.

**Comment:**

5. *The amount of post-hydrolysis solids (PHS) storage space needed and the timeframe for its storage should be provided. PHS may be stockpiled on the floor in the event it cannot be immediately fed into the boiler.*

**Response:**

5. There will be adequate floor storage allocated for approximately 12 hours' worth of PHS production, approximately 130 tons, essentially providing one shift to trouble shoot and remedy any issue preventing the normal processing of the PHS. The area dedicated to potentially excess PHS is depicted on the revised General Arrangement Process Diagram.

**Attachment 17, Air Quality**

**Comment:** *This section states that nuisance odors are expected to be contained within the building based on operations at comparable facilities. Additional information regarding which facilities were used for comparison and what information was obtained about them to reach this conclusion should be provided. Information from the existing Virginia facility may also be helpful.*

**Response:** The proposed Hampden facility operations and the configuration of the odor control system at Fiberight are unique. The unique configuration of the facility makes a direct comparison of odor control systems and operations with similar facilities in Maine impossible. The only other operationally similar facility is the Fiberight facility located in Lawrenceville, Virginia. The Lawrenceville, Virginia facility is smaller but operates in a similar manner to the proposed Hampden facility. According to Fiberight, there have been no odor related complaints at the Virginia facility. Fiberight will be the only solid waste processing facility that utilizes an ambient air capture system and an odor control scrubber system to control odors in the structure. Any odors that will be generated in the unprocessed waste storage and primary waste processing steps of the processing lines will be treated by the odor control system. Fiberight has designed the building to minimize the escape of potential nuisance odors from the structure.

Fiberight and MRC chose the proposed site, in part, based on its location in respect to separation from occupied buildings. The nearest occupied residence is located at a distance of approximately 3500' and is buffered by a generally forested area. Seasonal prevailing wind directions were evaluated based on 5 years of meteorological data collected at the Bangor International Airport (BIA). Given the proximity of BIA to the proposed site, and the similarities in topography, this data should be representative of the prevailing wind directions at the proposed site. During the spring and summer months when the potential for nuisance odors to exist is generally higher, the prevailing wind direction is to the north. This direction is away from the closest residences. During the autumn and winter months when the potential for nuisance

odor generation is the lowest, the prevailing wind direction is to the southeast. Neither of the conditions will convey potential nuisance odors in the direction of the nearest residences.

Nuisance odors could, potentially, be generated by trucks during queuing and departure from the site. During the first month of and for a total of 6 months during the first year of operation, a daily inspection and odor survey will be conducted around the facility. The daily inspection period must include the summer months when waste odors are expected to be strongest. If operations commence in the winter months and no odor issues are identified during the first month, inspections will be reduced to weekly until warmer weather. If after 6 months, including summer months, no odor issues are identified, inspections will be permanently reduced to weekly. Inspection results will be submitted to the Maine Department of Environmental Protection (MDEP) weekly unless an odor incident is noted in which case the MDEP will be notified within the day. The inspections will document current meteorological conditions and cleanliness of exterior operational areas at which there is the potential for nuisance odor generation in order to respond preemptively to avoid nuisance odor complaints. The Odor Management component of the O&M (Attachment 23) was revised to include the proposed inspection schedule and the form to be used.

### **Attachment 23, Operations & Maintenance Manual**

#### **Comment:**

1. *B.9, Routine Maintenance and General Cleanliness: The site-specific inspection and maintenance plan recommended by Victoria should include both indoor and outdoor components. In addition, a tipping floor management plan needs to be developed and include a discussion of MSW management within the tipping floor and unprocessed MSW storage areas.*

#### **Response:**

1. B.9, Routine Maintenance and Cleanliness: Section B.9 of the O&M has been updated to include site specific inspections and a maintenance plan including indoor and outdoor elements. Section B.11 was added to the O&M to include MSW management on the tipping floor. The revised O&M Manual is included in Attachment 23.

#### **Comment:**

2. *D.1, Acceptable Waste, Section 1 should describe how unacceptable waste will be handled. The facility needs to have a procedure for random inspection of incoming loads for hazardous or special wastes, and for preparing reports on the inspections. The location, design, size, and construction of the interim storage area must be shown on the facility site plan.*

**Response:**

2. D.1, Acceptable Waste: Screening for unacceptable waste will start at the scale house where the scale house attendant will randomly interview drivers as to the contents of their loads. A list of common unacceptable items will be clearly posted at the scale house. During the unloading process on the tip floor, a tip floor attendant will observe the loads as they are unloaded and examine any material suspected of being unacceptable waste. Additionally, the loader operator will continuously look for material that may appear to be unacceptable waste as the incoming material is spread, stockpiled, and eventually fed onto the conveyors feeding the Primary Sort Process. There will be a designated safe area on the side of the tip floor where a container(s) will be positioned such that any unacceptable waste will be set aside for temporary storage until appropriate disposal can be arranged. A storage area for unacceptable wastes is depicted on the General Arrangement Process Diagram and described in the O&M.

**Comment:**

4. D.4, Section 0.4 states that no liquid waste will be generated, except process wastewater from periodically purging the plant water system. Elsewhere the Application states that 36,000 gpd of wastewater will be generated. It is our understanding that the wastewater output will be 36,000 gpd. A clarification should be provided.

**Response:**

3. D.4, Clarification of Wastewater Quantity: The Mass Balance information provided to the MDEP has been updated to reflect the latest facility design information. The current expected average wastewater discharge will be 150,000 gpd. The wastewater is primarily made up of cooling tower blowdown accounting for roughly 66% of the wastewater discharged from the facility. Purge water from the waste processing system is approximately 33% of the wastewater generated, and there is a small contribution from the sanitary sewer system. Fiberight and CES are working with the Bangor Sewer District to accept this wastewater. A letter from Bangor Sewer District is included in Attachment 20.

**Comment:**

5. I., Annual Report: Items 1-4 will also need to include type of wastes, products, secondary materials, and residuals. Item 5 will need to include any responses to complaints received. Other necessary annual report information includes a complete description of residues leaving the site for disposal, including type and weight by destination, and data and results of waste characterization and analysis. The annual report will also need to include the demonstration required by Processing Facilities, 06-096 CMR 409(4)(1)(d) and (e) (last amended July 27, 2014).



**Response:**

5. I., Annual Report: The annual inspection section of the O&M manual was updated to include the additional requested information and is included in Attachment 23.

**Response to Memorandum Dated February 3, 2016**

**From:** Victoria Eleftheriou, P.E., Environmental Engineering Service Manager – Division of Technical Services

**To:** Lou Pizzuti, Environmental Specialist-Division Of Solid Waste Management

**Attachment 23, Operations and Maintenance Manual****Comment:**

2. *B.9., Routine Maintenance and General Cleanliness. A site-specific inspection and maintenance plan (Plan) will need to be established for the inspection and maintenance of the proposed processing facility infrastructure. Provisions for tracking maintenance needed and corrective actions performed should be included. A floor drain inspection and maintenance plan was provided as Deliverable #16. Applicable sizing calculations for the leachate trenches, common pit and common drainage tank should be provided. The common pit and drainage tank should be clearly illustrated on the General Arrangement Process Diagram. The Plan including Deliverable #16 should be appended to the facility Manual. In addition, the sample BMP Inspection Log and corresponding procedures should be appended to the Manual.*

**Response:**

2. B.9., Routine Maintenance and General Cleanliness: The attached O&M has been revised to include procedures for inspection and maintenance once the proposed facility begins operation.

The preliminary specification and layout of the leachate trenches, common pit, and common drainage tanks was established as per good engineering practice and anticipated facility operations. The trench system, as designed, will have the capacity to handle over 500 gallons per minute (gpm) of leachate and wash down water, which exceeds projected leachate generation and water usage estimates. The leachate is pumped to a 5,000 gallon common drainage tank prior to being metered into the pulper. The location of this tank is depicted on the updated General Arrangement Process Diagram. The trench system as described in Deliverable #16 is designed to allow for ease of periodic inspection and cleaning.

**Comment:**

3. *F. Odor Control. The Odor Management, Complaint, and Response Plan provided as Deliverable #19 should be appended to this section of the Manual. We have the following additional comments regarding this plan:*
  - b. *Section 4.0 should discuss provisions for odor minimization during timeframes when an odor control scrubber may be offline due to routine maintenance activities.*

- c. *Section 5.3 should provide an anticipated timeframe for procuring the specified odor neutralizing agents. MRC and Fiberright need to provide assurance that neutralizing agents as well as critical back-up equipment can be obtained in a timely manner.*

**Response:**

3. F., Odor Control

- b. The Odor Management, Complaint, and Response Plan has been updated to include methods to minimize potential nuisance odors during timeframes when the odor scrubber system is inoperable or operating at a limited capacity. The O&M has been updated to include specific odor neutralization application methods on the tip floor. This description has been included in Attachment 23.
- c. The Odor Management, Complaint, and Response Plan has been updated to specify odor neutralizing agents will be stored on-site in sufficient quantities to address odor issues on an as needed basis.



**WASTE AGREEMENT BETWEEN  
MUNICIPAL REVIEW COMMITTEE, INC.**

**AND**

**WASTE MANAGEMENT DISPOSAL SERVICES OF MAINE, INC.**

---

**WASTE DISPOSAL AGREEMENT**

**Between**

**MUNICIPAL REVIEW COMMITTEE, INC.**

**and**

**WASTE MANAGEMENT DISPOSAL SERVICES OF MAINE, INC.  
CROSSROADS LANDFILL**

## SOLID WASTE DISPOSAL AGREEMENT

AGREEMENT entered into this 24th day of August 2015, by and between the MUNICIPAL REVIEW COMMITTEE, INC. (hereinafter referred to as "MRC"), which currently represents 187 member municipalities that it anticipates continuing to serve after April 1, 2018, in accordance with this Agreement (each a "Participating Community" and collectively, the "Participating Communities") as designated on Exhibit B, and WASTE MANAGEMENT DISPOSAL SERVICES OF MAINE, INC., owner and operator of Crossroads Landfill located at 357 Mercer Road, Norridgewock, ME 04957 (hereinafter collectively referred to as "CROSSROADS").

I. MATERIALS. During the term of this Agreement, the MRC will cause Fiberight, LLC or its designee ("Fiberight"), as operator, to deliver to Crossroads Landfill, on an exclusive basis, and Crossroads agrees to accept, all of the nonhazardous residual material ("Residuals") generated at the municipal waste processing facility to be constructed and operated by Fiberight on a site leased from and owned by MRC located in Hampden, ME, or a successor municipal waste processing facility sponsored by the MRC ("MRC Facility"). Residuals shall be nonhazardous solid materials remaining after the processing at the MRC Facility of acceptable Municipal Solid Waste as defined under 06-096 CMR 400(1)(NNNN) and 35-A MRSA 3303(5) ("MSW" or "Acceptable Waste") that have not been recycled or reused. MRC expects, but does not guarantee, that the MRC Facility will generate approximately 40,000 tons per year of Residuals for disposal with a density of approximately 1,800 pounds per cubic yard. MRC shall be responsible for causing Fiberight to deliver Residuals to Crossroads for disposal in accordance with the delivery procedures of Crossroads in the form of Exhibit C as may be amended from time to time.

MRC also will cause to be delivered to Crossroads Landfill, on an exclusive basis, and Crossroads agrees to accept, all MSW generated within the Participating Communities designated as By-pass ("By-pass"). By-pass is unprocessed MSW requiring disposal after the start of commercial operations at the MRC Facility during periods when the MRC Facility is not able to receive said MSW. The MRC or its Participating Communities shall arrange for delivery of By-pass to Crossroads Landfill either directly from the MRC Facility or directly by the Participating Municipalities or their designees in accordance with Exhibit C.

MRC also will cause to be delivered to Crossroads Landfill, on an exclusive basis, and Crossroads agrees to accept, all MSW generated within the Participating Communities designated as Bridge Capacity ("Bridge Capacity"). Bridge Capacity shall be MSW collected within the Participating Communities and requiring disposal in the period between April 1, 2018 and the start of commercial operations of the MRC Facility (the "Bridge Period"). MRC expects to generate approximately 10,000 to 18,000 tons per month of MSW as Bridge Capacity during the Bridge Period, if any. The MRC or its Participating Communities shall arrange for delivery of Bridge Capacity MSW to Crossroads either directly from the MRC Facility or directly by the Participating Municipalities or their designees in accordance with Exhibit C.

Crossroads will accept unprocessed MSW delivered by or on behalf of Participating Communities that has been identified by the MRC for transfer to the MRC Facility. Crossroads will load MSW in the appropriate amounts into designated trailers while on site at Crossroads for delivery to the MRC Facility. MRC shall pay or cause to be paid by Participating Communities all costs for loading and trucking from Crossroads to the MRC Facility. The rate for loading to be paid to Crossroads is set forth in Section 4 of this Agreement.

Materials generated by the MRC, Fiberight or Participating Communities, which are collected by municipal vehicles, or private haulers under contract with MRC, Fiberight or any Participating Community, shall, at the time of delivery, be required to be identified to Crossroads, its agents or employees. Each person delivering Residuals, MSW as By-Pass and MSW as Bridge Capacity for the MRC, Fiberight or Participating Municipalities to Crossroads shall be required to furnish reasonable proof and assurance that the Materials delivered by such person originated at the MRC Facility or in a Participating Community and that such Participating Community or MRC has approved deliveries by such person and by such person's truck to Crossroads.

Crossroads may at any time refuse to accept for disposal any material, substance or property which in the good faith judgment of Crossroads is harmful, unhealthy or unsafe or in violation of any federal, state, or local statute, regulation, or rule applicable to the site. At the time of refusal, the identity of the entity responsible for delivery (if known), the nature of the rejected waste material and the reason for the rejection will be communicated to the MRC. See Exhibit A for hazardous, special and unacceptable wastes. In addition, Crossroads may refuse to accept Acceptable Waste that is not delivered in accordance with the terms of the Agreement, delivered outside of the operating hours of the site, or which it is unable to accept due to the occurrence of a Force Majeure Event.

2. SERVICES PROVIDED. Crossroads will provide, under terms of this Agreement, the following services:

- a) Disposal of all MSW, including without limitation, Residuals, By-pass and Bridge Capacity, at Crossroads Landfill, and loading of unprocessed MSW from Participating Communities onto MRC designated trailers for transport to the MRC Facility.
- b) Provide adequate supervision of disposal operations at Crossroads
- c) Remain open for the disposal of Materials between the hours of 7:15 A.M. to 3:30P.M., Monday through Friday and Saturday by appointment. Crossroads Landfill will be closed on Sundays and all legal holidays celebrated in the State of Maine and during any period where extreme or unusual weather conditions or similar hazards either prevent its operation or would make operations hazardous to persons and property. The MRC's contact (individual to be determined) shall be notified prior to any unscheduled closure of Crossroads Landfill. Maine state holidays are as follows: New Year's Day, Memorial Day, Independence Day, Labor Day, Thanksgiving Day and Christmas. For purposes of this Agreement, "business days" shall mean Monday through Friday, excluding holidays.

3. TERM. The term of this Agreement shall be for the period beginning April 1, 2018 and ending on March 31, 2028. Additionally, subject to mutual consent of the parties, the Agreement may be extended for up to (2) two periods of (5) five-years each by written agreement, not less than 90 days prior to the expiration of the then current term. MRC grants Crossroads the right of last refusal, as allowed by law, to match any valid written competitive offer for the services provided under this Agreement received by the MRC prior to expiration of the then current term or within ninety (90) days thereafter, should MRC not exercise its right to extend. The MRC shall provide written notice of any such offer, and Crossroads shall have fifteen (15) days from receipt of such notice within which to exercise its right of last refusal. The parties agree that both disposal fees and documented transportation costs to Crossroads Landfill and any other competing facility shall be included in the evaluation of total cost with respect to the right of last refusal granted to Crossroads hereunder. Notwithstanding the foregoing, upon request and reasonable notice provided by MRC and subject to approval of Crossroads, MRC can cause Bridge Capacity to be delivered to Crossroads Landfill, and Crossroads will accept such Bridge Capacity, prior to April 1, 2018, in accordance with the terms hereof applicable to delivery and acceptance of Bridge Capacity.

4. FEES and BILLING. The disposal fee for the first year of this Agreement shall be Forty-Seven Dollars and Zero Cents (\$47.00) per ton for Residuals, Sixty-Two Dollars and Zero Cents (\$62.00) per ton for MSW designated as By-Pass, and Sixty-Two Dollars and Zero Cents (\$62.00) for MSW designated as Bridge Capacity. The fee for loading at Crossroads Landfill of unprocessed MSW from Participating Communities for transfer by MRC designated trailers to the MRC Facility shall be Seven-Dollars and Fifty-Cents (\$7.50) per ton. The rates will be increased by 3% per year each April 1<sup>st</sup> beginning on April 1, 2019 and continuing for the entire term of this Agreement.

All Fees require that delivered materials will be acceptable to Crossroads pursuant to the terms of this Agreement and will ultimately be disposed at Crossroads Landfill, except for said MSW loaded onto MRC designated trailers for transport to the MRC Facility. During the term, should Crossroads be unable to dispose of Acceptable Waste at the Crossroads Landfill and such inability is not due to the occurrence of a Force Majeure Event, Crossroads will provide alternative delivery points for MRC to deliver, or cause to be delivered, said waste at the disposal fees in

effect at the time of delivery. In the event Crossroads closes due to reaching permitted capacity, said closure is expected to last for greater than 60 days and the alternate delivery point provided by Crossroads is 20% greater in distance, then Crossroads shall provide to MRC written notice of its anticipated closure date at least one hundred and eighty (180) days in advance of such date whereupon the parties agree to immediately enter good faith negotiations for the disposal fee at said alternate delivery point. Should the parties fail to reach agreement on the disposal fee at the alternate delivery point, then MRC shall be allowed to terminate the Agreement upon closure of Crossroads by providing 60 days notice to Crossroads.

Invoices for disposal of Residuals, Bypass and Bridge Capacity, and for loading of unprocessed MSW into MRC designated vehicles for delivery to the MRC Facility, will be sent directly to MRC on or about the first and fifteenth days of each month. Copies of invoices for disposal of Residuals and Bypass will also be sent to Fiberight. Payment is required within thirty (30) days from date of invoice. In the event that payment is not made when due, Crossroads shall notify the MRC and Fiberight or a Participating Community, as applicable. Crossroads will be entitled to charge a late fee to the maximum amount allowed by law, suspend acceptance of Residuals from Fiberight, or suspend acceptance of MSW and or By-pass from a Participating Municipality. If payment is not made within fifteen days after suspension of acceptance, then Crossroads may terminate the Agreement in accordance with Section 13 of this Agreement. MSW shall be delivered to Crossroads Landfill, or to an alternative disposal facility, by the MRC, Participating Community or their designee at the cost of the MRC or Participating Community. Notwithstanding the foregoing, Crossroads shall not be entitled to charge a late fee or to terminate this Agreement for nonpayment during any period in which MRC, Fiberight or a Participating Community, as the case may be, is disputing in good faith the amount of such payment.

In the event that any federal, state, or local body or agency adopts or implements any law, rule, regulation or order respecting the disposal which results in an increase in the cost of facility operations or levies a tax on waste disposal and recycling operations at the facility, one hundred percent (100%) of any such increase cost or tax shall be allocated, in proportion to the tonnage delivered among the municipalities and other customers which deliver materials to the Crossroads Landfill.

The MRC or Participating Communities shall be notified at least thirty (30) days in advance of the increase resulting from such law, rule, regulation or order. Further, the specific law, rule, regulation or order shall be identified and the specific proportional percentage or dollar amount shall be specifically noted.

5. UNACCEPTABLE WASTE. No special ("Special Waste") or hazardous waste ("Hazardous Waste") or other types of waste as defined on Exhibit A ("collectively referred to as "Unacceptable Waste"), may be disposed at Crossroads without the prior written approval of the Crossroads District Manager. To obtain such approval, MRC, Fiberight or any Participating Community, as the case may be, must supply at its own expense, to Crossroads such information, as Crossroads deems necessary, including sampling and analysis of the waste, on such forms as Crossroads shall require. Crossroads may require written approval from the Maine Department of Environmental Protection for disposal of the Special Waste. In the event Unacceptable Waste is approved for disposal, a separate disposal rate will be charged. Such rate will be negotiated on a case- by- case basis.

In the event that Unacceptable Waste is discovered to have been transported from Fiberight, the MRC or any Participating Communities to and/or disposed at Crossroads Landfill, ownership of the Unacceptable Waste shall remain with Fiberight or the Participating Community from which it emanated, if identified, otherwise to the MRC. Upon written notification of violation, the prompt removal of the material from Crossroads shall be done in a manner, which is lawful, non-injurious to public health, environmentally sound and safe. All costs related to removal of Unacceptable Waste shall be borne by Fiberight or by the Participating Community responsible for its delivery, or, if Fiberight or a Participating Community could not be identified, by MRC.



6. DELIVERY OF ACCEPTABLE WASTES. Deliveries of Residuals, Bypass and Bridge Capacity, and of unprocessed MSW for loading and delivery to the MRC Facility, shall be comprised of Acceptable Waste generated and collected within the MRC Facility or from municipal collection operations or municipal solid waste transfer stations of Participating Communities, whether by municipal operations or by direct contract with a hauler, unless by written authorization from the MRC and a Participating Community, a hauler is designated to make private deliveries on behalf of a Participating Community.

Evidence that Acceptable Waste brought to Crossroads originated other than from the MRC Facility or a Participating Community, or in any other way was unauthorized for disposal under this Agreement, is grounds for excluding the responsible hauler, collector, or business concern from the use of the Crossroads Landfill; provided, however, that Crossroads shall issue not less than one (1) warning, with a copy to the MRC, in lieu of termination of disposal privileges prior to any such exclusion. The MRC shall be notified of the identity of the violator and the evidence and circumstances surrounding the exclusion.

Admission to the Crossroads Landfill shall be controlled solely by Crossroads and its authorized employees. Crossroad's determination of the municipal origin of the waste shall be final.

7. FACILITY PROCEDURES. Crossroads will provide a safe environment for the disposal of Acceptable Waste from Participating Communities and the MRC Facility. Crossroads shall at all times comply with all applicable local, state, and federal laws and regulations and facility permits regarding the disposal of Acceptable Waste from the MRC Facility and MRC Participating Communities. Haulers, collectors, and business concerns using Crossroads Landfill for disposal of wastes will comply with Crossroads posted safety procedures while at Crossroads and will obey the instructions of Crossroads authorized employees during disposal and at all times in the event of an emergency situation at Crossroads.

8. INDEPENDENT CONTRACTOR. Crossroads is, and shall perform its obligations under this Agreement as, an independent contractor and as such, shall have and maintain complete control over all its employees, agents and operations. Neither Crossroads, nor anyone employed by it shall be, represent, act, purport to act, or be deemed to be the agent, representative, employee, or servant of the MRC or its Participating Communities.

9. INSPECTIONS. During normal business hours, and with reasonable notice, in no event less than twenty-four hours, the MRC shall have the right to inspect and obtain copies of all written licenses, permits, and approvals issued by any federal, state or local government agency to Crossroads, which are applicable to the performance of obligations under this Agreement.

10. EXCUSE OF PERFORMANCE. Either party may suspend the performance of obligations under this Agreement, except for the payment for services already rendered, for a definite or indefinite period as circumstances require in the event of an act of force majeure ("Force Majeure" or "Force Majeure Event"). Force Majeure Event shall mean any act or event beyond the control of the parties, which materially and adversely affects the performance of this Agreement, including without limitation:

- a) strikes or work stoppages at the facility ;
- b) any destruction of or damage to or any interruptions, suspension or interference with the operation of the facility caused by:
  - i. acts of god, epidemic, landslide, lightning, earthquakes, fires, explosions, storms, floods, or similar occurrences, or
  - ii. acts of the public enemy, wars, blockades, insurrections, riots, arrests, restraints of governments and people, civil disturbances or similar occurrences;

c) any act or failure to act of any government, subdivision or instrumentality thereof, including any change in laws or regulations or interpretations thereof which prohibit or materially and negatively impacts the operation of the Crossroads Landfill as necessary to provide the services contemplated herein; or

d) Suspension, termination or interruption of utilities.

If any act or event of force majeure occurs, the party affected shall deliver written notice to the other within 48 hours setting forth such information available to it of the act or event of force majeure.

If any act or event of force majeure occurs which prevents Crossroads from accepting MSW at the facility, the MRC, Fiberight or Participating Communities may elect to dispose of the Acceptable Waste by some alternative means, in which event, it will do so at its own cost. The MRC shall cause deliveries of Acceptable Waste to Crossroads to be reinstated within 5 business days after receipt of notice from Crossroads that such act or event of force majeure has ceased affecting the operation of Crossroads. If any Force Majeure Event prevents Crossroads performance of its obligations under this Agreement for a period of greater than 60 days, the MRC shall have the right to terminate this Agreement by providing seven (7) days advance written notice.

11. INDEMNIFICATION. Crossroads agrees to indemnify, defend and save harmless MRC, Fiberight, Participating Communities and their respective members, directors, officers, elected officials and agents (each an "MRC Indemnified Party") from and against any and all liability which an MRC Indemnified Party may be responsible for or pay out as a result of bodily injuries (including death), property damage, or any violation of law, to the extent caused by any negligent act, negligent omission or willful misconduct of Crossroads or its employees, agents or contractors after the effective date and throughout the term of this Agreement.

MRC agrees to indemnify, defend and save Crossroads harmless from and against any and all liability which Crossroads may be responsible for or pay out as a result of bodily injuries (including death), property damage, or any violation or alleged violation of law to the extent caused by any negligent act or omission or willful misconduct of the MRC or its employees, agents or contractors in the performance of the Agreement.

In no event, whether in contract, tort or otherwise, shall either party be liable to the other for any indirect, special, incidental, consequential or punitive damages.

12. NOTICES. During the term of this Agreement and any extension thereof and until otherwise notified by the other party, all notices sent or required to be sent hereunder shall be by registered mail or privately overnight delivery service, postage prepaid, addressed as follows, and shall be deemed given when delivered for mailing to a United States Post Office so addressed.

To MRC:                               Municipal Review Committee  
395 State Street  
Ellsworth, ME 04605  
Attention: Executive Director  
Email: [glounder@mrcmaine.org](mailto:glounder@mrcmaine.org)

To Crossroads: District Manager  
Waste Management Disposal Services of Maine, Inc.  
P.O. Box 629  
357 Mercer Road  
Norridgewock, ME 04957

With Copy to: General Counsel  
Waste Management of Maine Inc.  
4 Liberty Lane West  
Hampton, NH 03842

13. DEFAULT. Should Crossroads fail or refuse to operate the facility substantially in accordance with this Agreement, unless such failure or refusal shall be excused or justified by a force majeure or is due to default by the MRC and if such failure or refusal is of a material nature, then the MRC shall have the right to terminate this Agreement by written notification after Crossroads has been given 30 days to resolve the problem or in the case of a force majeure event 60 days to resolve the problem. The MRC shall have the right to recover from Crossroads the actual damages suffered by Fiberight, the MRC or Participating Communities as a result of the act or failure of Crossroads in performing its obligations under this Agreement. Should the MRC fail or refuse to perform its obligations under this Agreement, and if such failure is not caused by Crossroads' default and is of a material nature, then Crossroads shall have the right to terminate with 30 days written notification and opportunity to cure.

14. DISPUTE RESOLUTION. In the event any claim, controversy or dispute arises between Crossroads and the MRC or Participating Communities, the MRC and Crossroads shall first negotiate in good faith to resolve the dispute; provided however, that neither party waives any right to any action available at law or in equity. In the event of any litigation arising out of this Agreement, the prevailing party shall be entitled to its reasonable attorneys' fees and costs.

15. FORM OF CONSENT. All consents of any kind required under this Agreement shall be in writing. Whenever, under this Agreement, the MRC is authorized to give consent, such consent may be given and shall be conclusively evidenced by the authorized representative of the MRC giving such consent. Whenever under the terms of this Agreement, Crossroads is authorized to give its consent; such consent may be given and shall be conclusively evidenced by writing certified by its District Manager.

16. ASSIGNMENT. Crossroads may not assign this Agreement without the written consent of the MRC which consent shall not be unreasonably withheld. The MRC may assign the Agreement only to a successor public regional entity, which assumes all rights and obligations of the MRC.

17. AMENDMENT. This Agreement may be amended from time to time by written agreement duly authorized and executed by the parties hereto.

18. GOVERNING LAW. This Agreement shall be governed and construed under and pursuant to the laws of the State of Maine without regard to any conflicts of laws principals.

19. MISCELLANEOUS.

a) If any provision of this Agreement or any portion of such provision, or the application thereof to any circumstances or person is held invalid, the remainder of this Agreement, or the remainder of such provision, and the application thereof to other persons or circumstances shall not be affected thereby.

b) Audit of Records - The monitoring and auditing of Crossroads scale records and individual delivery weight slips that support the charges under this Agreement, by MRC shall be allowed on an annual basis as requested, subject to forty-five days' written notice by MRC to Crossroads. If third party consultants are employed by MRC, such consultants shall be required to execute a confidentiality agreement. .

c) Record Retention - Crossroads shall maintain all weight and scale records in relation to this Agreement for a period of at least five (5) years after the end of the Contract period.

d) Record Ownership - All records, reports, documents, or other material related to this Agreement and/or obtained or prepared by Crossroads for MRC in connection with the performance of the services contracted for herein shall become the property of the MRC, and shall, upon request, be returned to the MRC, at Crossroads expense, at the termination or expiration of this Agreement.

20. INSURANCE Crossroads shall obtain and maintain all insurance required by these specifications and provide the MRC with a certificate of insurance for all required insurance. The minimum insurance requirements, indemnity provisions, and waiver provisions for all work or services for the MRC shall be as follows:

Worker's Compensation	Per Statute	
General Liability		
Personal/Bodily Injury	\$ 1,000,000	per incident
	\$ 2,000,000	aggregate
Property Damage	\$ 1,000,000	per incident
	\$ 2,000,000	aggregate
Automobile Liability	\$ 1,000,000	per person
	\$ 2,000,000	each accident

Crossroads shall name the MRC and the MRC's Participating Communities, its boards, officers, agents and employees as named insured in any and all required insurance policies to the extent of its liability under this Agreement. Crossroads shall not cancel any required insurance policies. Crossroads shall not modify or replace any required insurance without thirty (30) days prior written notice to the MRC.

21. OWNERSHIP OF WASTE Title to all Acceptable Waste delivered to the disposal facility shall pass to Crossroads when deposited at the Crossroads Landfill (i.e., at the working face or tip floor). Title to and liability for Unacceptable Waste shall remain with the MRC, Fiberight or the Participating Community delivering it, as the case may be, until acceptance of delivery. At no time will Crossroads accept title to Unacceptable Waste, unless Crossroads agrees in writing to accept the Unacceptable Waste, after reviewing and approving a waste profile supplied by MRC or a Participating Community at which time the Unacceptable Waste shall be deemed to be Acceptable Waste and Crossroads shall accept title to the waste

22. ENTIRE AGREEMENT. This Agreement constitutes the entire Agreement and understanding between the MRC and Crossroads, and it shall not be considered modified, altered, changed, or amended in any respect unless in writing and signed by both parties hereto.

23. NON-APPROPRIATION. The MRC's multi-year obligations under this Agreement are conditioned upon the Participating Communities continuing to allocate funds throughout the term of this Agreement to continue its solid waste collection programs. The MRC's budget is prepared annually with its fiscal year commencing January 1 and ending December 31. Should the MRC anticipate that funds will not be appropriated to maintain its Participating Communities' solid waste collection programs, the MRC will give notice of same as soon as practicable.

24. CONSENTS. Crossroads acknowledges that the MRC or Fiberight may request to have Crossroads reaffirm the obligations under this Agreement in the form of an additional consent agreement, acknowledgement agreement or similar document that would be part of the business arrangements to support investment in or financing of the MRC Facility. Crossroads agrees to provide such reaffirmation document in reasonable form.

IN WITNESS WHEREOF, the parties hereto have hereunto set their hands and seals on the 24th  
Day of August, 2015.

  
Witness

WASTE MANAGEMENT DISPOSAL  
SERVICES OF MAINE, INC.

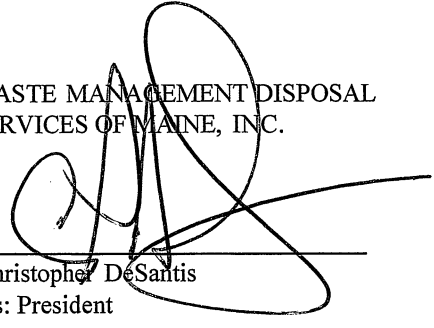
  
Christopher DeSantis  
Its: President

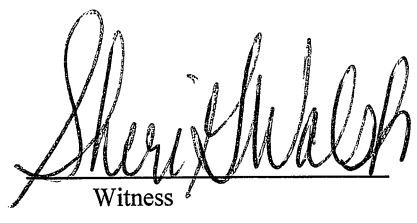
  
Witness

MUNICIPAL REVIEW COMMITTEE, INC.

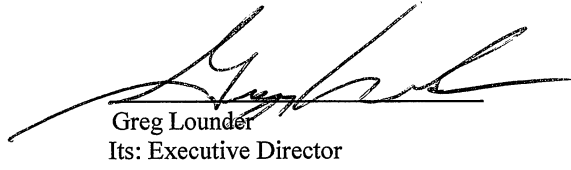
  
Greg Louder  
Its: Executive Director

**SHERI G. WALSH**  
Notary Public, Maine  
My Commission Expires April 6, 2020

## EXHIBIT A

A. "Hazardous Waste" means:

(1) Any material or substance or hazardous substance, which, by reason of its composition or characteristics, is;

(a) Toxic or hazardous waste or hazardous substance as defined in either the Solid Waste Disposal Act, 42 U.S.C. 6900 et seq., as replaced, amended, expanded or supplemented the Resource Conservation and Recovery Act, 42 U.S.C. 6903, as replaced amended, expanded or supplemented, or any laws of similar purpose or effect, and such policies or regulations thereunder, or any laws of similar purpose or effect, and any rules, regulations or policies thereunder, or;

(b) Special nuclear or by-product materials within the meaning of Atomic Energy Act of 1954;

(2) Other materials which any governmental agency or unit having appropriate jurisdiction shall determine from time to time is harmful, toxic or dangerous, or otherwise ineligible for disposal in the landfill; and

(3) Any material, which would result in Process Residue being Hazardous Waste under (1) or (2) above.

B. "Unacceptable Waste" means:

1. A containerized waste (i.e., drum, barrel, portable tank, box, pail, etc.) listed in 3-8 below.

2. A waste transported in bulk tanker.

3. A liquid waste.

4. A sludge waste.

5. A waste from an industrial process.

6. A waste from a pollution control process.

7. Residue and debris from a cleanup of a spill or release of chemical substances, commercial products or waste listed in 1 - 6 or 8.

8. Contaminated soil, water, residue, debris and articles from the cleanup of a site or facility formerly used for the generation, storage, treatment, recycling, reclamation or disposal of wastes listed in 1 -7.

9. Chemical waste from a laboratory.

10. Articles, equipment and clothing containing or contaminated with polychlorinated byphenyls (PCBs).

11. PCB drainings and flushings removed from PCB articles and placed directly into transport containers.

12. "Empty" containers of waste commercial products or chemicals (this applies to a portable container which has been emptied, but which may hold residuals of the product or chemical. Examples of containers are: portable tanks, drums, barrels, cans, bags, etc.)

13. Asbestos contained in or from waste from building demolition or cleaning.

14. Commercial products or chemicals whether off-specification, outdated, contaminated or banned.

15. Residue and debris from cleanup of spills or releases of a single chemical substance or commercial

product or a single waste, which would otherwise qualify as a miscellaneous special waste.

16. Infectious waste. (Any waste from a hospital, medical clinic, nursing home, medical practitioner, mortuary, taxidermist, veterinarian, veterinary hospital, animal testing laboratory, university medical laboratory, etc., that, to an extent that distinguishes it from typical household waste, is contaminated with or may be contaminated with an infectious agent that has the potential of inducing infection. These wastes are wastes if they are untreated, autoclaved or otherwise heat-treated.)
17. Animal waste and parts from slaughterhouses or rendering plants, including wastes from fur or leather products manufacturing.
18. Waste produced by mechanical processing of fruit, vegetables or grain, rinds, hulls, husks, pods, shells, and chaff, food processing wastes which are aqueous or sludges, or which have been contaminated with dyes, additives or preservatives.
19. Pumpings from septic tanks used any size exclusively by dwelling units.
20. Sludges from a publicly owned sewerage treatment plant serving primarily domestic users.
21. Grease trap wastes from residences, restaurants, or cafeterias not located at industrial facilities.
22. Washwater wastes from commercial laundries or laundromats including waste from dry cleaning facility or waste from a commercial laundry used by an industry to wash chemical-contaminated clothing from its workers.

EXHIBIT B  
LIST OF PARTICIPATING MRC COMMUNITIES

This list of Participating Communities is current as of July 2015. CROSSROADS and MRC acknowledge that a small number of municipalities may be added to or subtracted from this list prior to April 1, 2018. MRC will keep CROSSROADS informed on an ongoing basis of changes in the list

Abbot  
Albion  
Alton  
Atkinson  
Baileyville  
Bancroft  
Bangor  
Bar Harbor  
Belfast  
Blue Hill  
Boothbay RRDD  
Bowerbank  
Bradley  
Brewer  
Brooks  
Brownville  
Bucksport  
Burnham  
Carmel  
Castine  
Central Penobscot  
Cherryfield  
Chester  
China  
Clifton  
Clinton  
Cranberry Isles  
Cushing  
Dedham  
Dixmont  
Dover-Foxcroft  
Drew Pt  
East Millinocket  
Eddington  
Edinburg  
Enfield  
Etna  
Fairfield  
Franklin  
Freedom  
Friendship  
Garland  
Glenburn



Gouldsboro  
Greenbush  
Guilford  
Hampden  
Hancock  
Harrington  
Haynesville  
Hermon  
Holden  
Howland  
Hudson  
Jackson  
Kenduskeag  
Knox  
LaGrange  
Lamoine  
Lee  
Levant  
Lincoln  
Lucerne  
Machias  
Macwahoc Pt  
Mariaville  
Mars Hill  
Mattawamkeag  
Maxfield  
Medford  
Medway  
Midcoast SWD  
Mid-Maine SWD  
Milbridge  
Milford  
Millinocket  
Milo  
Monson  
Montville  
Mt. Desert  
N.Katahdin  
Newburg  
Oakfield  
Old Town  
Orland  
Orono  
Otis  
Owls Head  
Palmyra  
Parkman  
Passadumkeag  
Penobscot Co.  
Penobscot Town

Piscataquis Co.  
Pleasant River SWD  
Plymouth  
Reed Plt  
Rockland  
S. Thomaston  
Sangerville  
Searsmont  
Searsport  
Sebec  
Sherman  
Sorrento  
Springfield  
Stetson  
Steuben  
Stockton Springs  
Stonington  
Sullivan  
Surry  
SW Harbor  
Swans Island  
TCSWMO  
Thomaston  
Thorndike  
Tremont  
Trenton  
Troy  
Union River SWD  
Unity  
Vassalboro  
Veazie  
Verona  
Waldoboro  
Waterville  
West Gardiner  
Winn  
Winslow  
Winter Harbor  
Winthrop  
Wiscasset

## EXHIBIT C

### CROSSROADS LANDFILL, NORRIDGEWOCK, ME DELIVERY PROCEDURES

#### Transporter Rules and Regulations

As the acknowledged leader in the solid waste industry, our responsibility is to establish and maintain the highest waste management standards.

These standards provide maximum protection to our customers, employees, and the community, ensuring that we conform to both the letter and the spirit of all laws, regulations and permits governing our operations.

A key component of this management process is the transportation of wastes to our facility. Safe transport is as important as safe disposal. Hence, we have developed very stringent transporter requirements to ensure the safety of our employees, our neighbors, and people in the communities in which we do business. Moreover, our concern for safety demands that we rigidly enforce these rules and regulations.

Therefore, we require that EVERY driver obey the letter and the spirit of all Local, State and Federal laws, and our WMDSM-Crossroads transporter rules and regulations. Your safety, as well as the safety of our employees and the public depends upon it.

#### WMDSM-Crossroads compliance:

Transporters will comply with all Federal and State DOT requirements, as well as Maine DEP requirements. All transporters will also comply with this document, the WMDSM-Crossroads Transporter Rules and Regulations.

#### Scheduling:

- All trucks will be scheduled for arrival on site during operating hours.
- No trucks can arrive and park at the facility before operating hours commence.
- Trucks carrying wastes will be scheduled for arrival during the hours of 7:30 a.m. and 3:30 p.m. (unless prior approval is given).

#### Designated Route:

- All trucks must travel on State/Federal Highways.
- This also applies to vehicles leaving the facility.
- Absolutely NO DEVIATION from the designated route.

#### Community Requirements:

- Observe all posted speed limits.
- Observe extreme caution in school zones.
- Do not use engine (Jake) brakes in the town of Norridgewock.
- Ensure all loads are secured to prevent litter and odor issues.

Non-Compliance:

Non-compliance with any of the above rules may result in rejection or delay in servicing of the specific load and/or exclusion of the non-complying driver from the facility.

- A first offense will subject the driver to a verbal warning.
- A second offense by the same driver within one month will subject the driver and hauling contractor to a written warning.
- A third offense within one month will subject the driver to a 2 week ban from the facility.

THE TRANSPORTER AGREES AND CERTIFIES THAT:

- A. ALL TRANSPORTER employees will comply with all Federal, State and Local Safety Laws and Rules.
- B. ALL TRANSPORTER employees will comply with all WMDSM-Crossroads Safety and Operating Rules and Regulations as posted by signs or communicated by other means at the Norridgewock, Maine facility.
- C. ALL TRANSPORTER employees have been trained in the applicable work tasks to be performed by them.
- D. ALL TRANSPORTER employees, working in the site designated asbestos area, will be trained and are medically qualified.
- E. ALL TRANSPORTER employees will observe the facility scheduled receiving hours.
- F. ALL TRANSPORTER employees have been properly instructed to insure strict observation of all safety rules, regulations and routing.
- G. ALL TRANSPORTER employees have been provided with a copy of this document and instructed to carry it in their vehicles at all times.
- H. HE/SHE will take positive action to cause all such employees to comply with all laws, rules and regulations contained in this document.

---

Signature of Contractor/Authorized Agent

---

Date

---

Company Name

---

Company Address

**UPDATED MASS BALANCE**

**AND**

**PROCESS FLOW DIAGRAM**

## Hampden Maine Mass Balance Summary

Stream	Recovered	Disposed	Total
Bulkies - Primary Sort	3	5	8
OCC - Primary Sort	18	0	18
Textiles - Primary Sort	0	7	7
Trash - Primary Sort	3	3	6
Grit/Glass- Secondary Sort <sup>1</sup>	29	0	29
Grit - Wash <sup>1</sup>	4	0	4
Fe - MRF Sort	14	0	14
Non-Fe - MRF Sort	6	0	6
Film - MRF Sort	33	0	33
Trash - MRF Sort <sup>2</sup>	0	120	120
HDPE - MRF Sort	7	0	7
PETE - MRF Sort	6	0	6
Mixed Plastics - MRF Sort	8	0	8
Comb DAF Residues - AD Feed	40	18	58
Bio-gas - AD Plant	58	0	58
PHS (Net of Ash)	246	0	246
Combined Boiler Ash	0	24	24
<b>Totals</b>	<b>475</b>	<b>177</b>	<b>652</b>

Note 1: Washed Grit/Glass intended to be used as Alternative Daily Cover (ADC)

Note 2: 45-50 TPD of the listed 120 TPD of trash is potentially recoverable material subject to economically converting it to a marketable condition

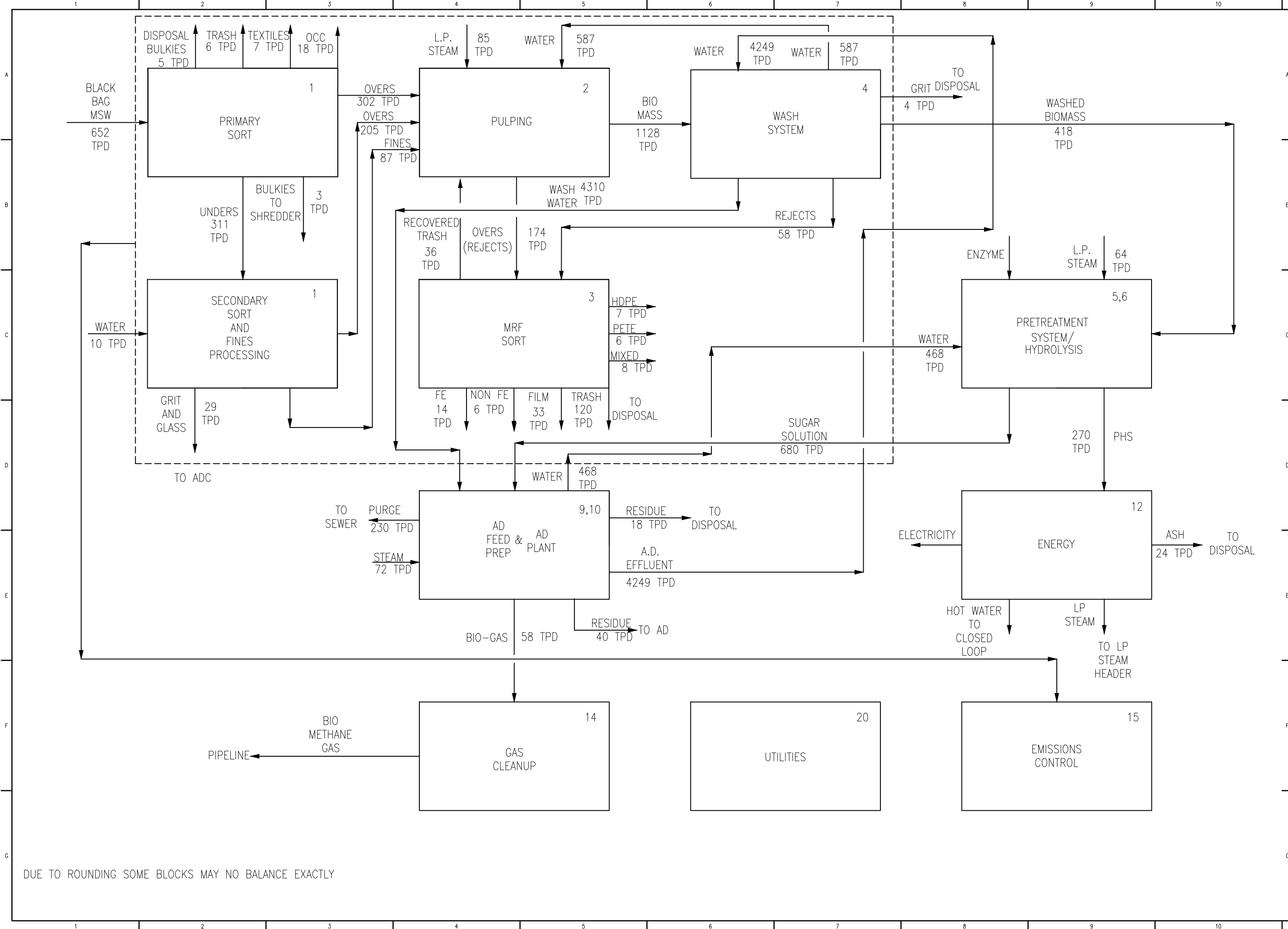

DUE TO ROUNDING SOME BLOCKS MAY NO BALANCE EXACTLY

FiberTt LLC  
 PO Box 21171 Catonsville, MD 21228  
 www.FiberTt.co

REV	DATE	DESCRIPTION
A		ISSUED FOR REVIEW
		ST
		DR
		REVIEW
		APPROVE

PROJECT NO:  
 DESIGNED BY: Fiberright  
 DRAWN BY: Andy Gotsch  
 REVIEWED BY:  
 PLOT SCALE: 1:1  
 PLOT DATE: 28MAR16

BLOCK DIAGRAM  
 AS RECEIVED  
 MASS BALANCE

**MAINE**

**ATTACHMENT 13**

**PROCESS DESIGN INFORMATION**



## ATTACHMENT 13 - REVISED

### PROCESS DESIGN INFORMATION

The following information describes the facility's waste processing system in accordance with 06 096 CMR Chapter 409.3.C (Process Design Characteristics).

#### Process Flow Diagram

Included in this Attachment is an overall process flow diagram outlining the general procedures for handling and processing municipal solid waste (MSW) at the Fiberight facility.

#### Source and Volume of MSW

The proposed Fiberight facility is expected to receive an average of 410 to 550 tons of MSW per day. To account for seasonal fluctuations in waste deliveries, the facility will be designed to accept up to 950 tons and process up to 650 tons of MSW per day. MSW accepted at the facility will originate from within MRC communities, other communities that have relied on PERC for MSW disposal and any other communities interested in utilizing the Fiberight facility for disposal services.

#### Characteristics of Waste to be Received

In general, MSW that is accepted at the facility includes solid waste emanating from household and normal commercial sources. MSW includes front end process residue from the processing of MSW. MSW generally includes but is not limited to food waste and other types of organic waste, plastics, construction and demolition debris, metals, glass, household hazardous waste, and other types of miscellaneous waste disposed with normal household and commercial refuse.

#### Products and Waste Generated

As shown on the attached process flow diagram, Fiberight will process MSW received into the facility into several different categories. The resultant products generated at the facility will include recyclables which will be sold on the open commodities market; post hydrolysis solids (PHS) which will be used to fuel the on-site biomass boilers; bio-methane which will be piped to the adjacent Bangor Natural Gas Loring Pipeline; and biomass fuel which will be sold on the open commodities market.

The resultant residue waste products generated at the facility will be removed via screens in the first sort of the production process. This waste is typically 2 inches or less in size and once removed, will be loaded out on walking floor semis and transferred for disposal at a licensed landfill facility. Materials considered to be residues will be removed from the facility as soon as possible but no longer than 24 hours of the container becoming full. A breakdown of the residues to be landfilled is included in this Attachment.

### **Methods Utilized to Mix Waste**

Refer to the *Maine Process Description* document provided by Fiberight and included in this Attachment.

### **Methods Utilized to Process Waste**

Refer to the *Maine Process Description* document provided by Fiberight and included in this Attachment.

### **Methods Utilized to Store Waste**

MSW will enter the facility and be unloaded on a tipping floor located inside the building. The tipping floor is designed with capacity for approximately two days of MSW receipts and two days of primary processed material. The MSW is moved from the tipping floor to the processing line as quickly as possible. The efficiency of the processing operation is partially reliant on the facility continuously processing the organics for entry into the wash stage of the process prior to decomposition. Fiberight will utilize the principle of First-In-First-Out operation to the maximum extent possible to minimize the residence time of waste on the tipping floor. The method used to demonstrate the First-in-First-Out principle is being implemented is described in the revised O&M.

Residue Storage: Residues generated from sorting through normal operations which results in material needing to be landfilled. These materials will include bulkies, textiles, trash, and combined diffused air flotation (DAF) residues. The residues will either be routed directly and/or loaded into a staged dump or walking floor trailer. With the volumes of these materials being produced, it is expected that this trailer will be filled every 3-4 hours depending on the overall average density of the combined residue stream. Residues will not be stored on-site for any longer than 24 hours. Once a container or trailer is full, the container will be transferred off-site for disposal as soon as possible but, at a maximum, by end of business the following day.

Biomass Boiler Ash: Fiberight estimates that the facility may generate 3,000 to 4,000 tons of ash per year. The ash generated on-site will be the result of utilizing post hydrolysis solids (PHS) to fuel two biomass boilers on-site. The boilers will be used to supply power for facility operations. Ash generated will be stored in 40 cubic yard ash bins inside the building. When bins become full, ash will then be loaded into 100 cubic yard transport trailers and transported off-site to a licensed secure landfill for final disposal. Full containers will be removed from the site as soon as possible but at a maximum, by end of business the following day.

### **Methods Utilized to Store Products**

Recyclable Storage: Recyclables removed from the waste that can be baled on-site will be temporarily stored in 100 cubic yard transport trailers. Larger metal recyclables that cannot be baled will be stored in 40 cubic yard dump trailers. Recyclables will only be stored on-site long enough to fill transport trailers and then will be shipped and sold as commodities on the open market.

Secondary Materials Storage: Washed glass and grit will be removed from the process separate from process residues. Fiberight intends to provide this material to a landfill to be reused for shaping, grading or alternative daily cover materials at a landfill or as aggregate

material in construction at a landfill. The grit and glass will be deposited into a 40 cubic yard container, of which one would be filled in 23-24 hours.

Post Hydrolysis Solids (PHS): The filtered Post Hydrolysis Solids (PHS) are discharged from the filter press and sent to two biomass boilers which will provide energy for the process. PHS will be continuously fed from the filter press to the biomass boilers and therefore long term storage of this material is not anticipated. In the unlikely event that PHS cannot be continuously fed to the boiler, PHS will be temporarily stockpiled on the floor adjacent to the boiler feed conveyor hopper. There will be adequate floor storage allocated for approximately 12 hours' worth of PHS production. The area depicted on the General Arrangement Process Diagram for PHS storage will accommodate approximately 130 tons of boiler fuel. After the boiler is back on line and able to accept PHS, PHS will then be loaded onto the boiler feed conveyors using a Bobcat loader.

Bio-methane: Bio-methane generated at the facility will be injected into the adjacent Bangor Natural Gas pipeline. No on-site storage of bio-methane is proposed for this project.

Industrial Sugar: Industrial sugars produced at the facility will be stored in Sugar Storage Tanks to be shipped and sold as industrial sugar or the filtered hydrolysate is fed to the anaerobic digestion plant for conversion to biogas. The exact disposition of the filtered hydrolysate is dependent on current contractual, market, and operational conditions.

### **Processing Equipment Used On-site**

Refer to the *Maine Process Description* document provided by Fiberight and included in this Attachment.

### **Provisions for Characterization**

In accordance with 06 096 CMR Chapter 405.6.C. solid wastes proposed to be disposed at a solid waste disposal facility must be characterized in conformance with the requirements listed in 06 096 CMR Chapter 405.6.C. Fiberight will be producing non-organic residues and ash requiring disposal at a licensed solid waste facility. Non-organic residues which may be classified as "Miscellaneous Wastes" listed in 06 096 CMR Chapter 405.6.C.(2). The analytical requirements listed include the following:

- ◆ Complete Toxicity Characteristic Leaching Procedure (TCLP) (per US EPA Method 1311, Federal Register/Volume 55, No. 126, 1992);
- ◆ Totals for Aluminum, Arsenic, Barium, Boron, Cadmium, Chromium, Copper, Lead, Mercury, Molybdenum, Nickel, Selenium, Silver, and Zinc (per Methods in US EPA SW-846);
- ◆ Chloride, percent carbon, percent moisture, pH, phosphorus;
- ◆ Reactivity Characteristics;
- ◆ Ignitability Characteristics; and
- ◆ Additional parameters as identified by the applicant or the Department. These additional parameters must be based upon the raw material, the proposed activity, or the facility.

Fiberight anticipates generating between 3,000 and 4,000 tons of ash per year in the facility's biomass boiler. Ash will be disposed of in a landfill licensed to accept it and will be characterized in accordance with 06 096 CMR Chapter 405.6.C(4) and sampled for those parameters listed for biomass and fossil fuel boiler ash. Prior to initial acceptance at a solid

waste facility, a sufficient number of samples to meet the requirements for statistical analysis as required by USEPA SW-846 must be analyzed as follows:

- ◆ TCLP Metals (Arsenic, Barium, Cadmium, Chromium, Lead, Mercury, Selenium, Silver) per US EPA Method 1311, Federal Register/Volume 55, No. 126, 1992; and
- ◆ Chloride, percent carbon, percent moisture, pH, phosphorus.

After initial characterization is complete, ash must be analyzed for the parameters listed above at a frequency of one representative sample quarterly.

### **Waste Derived Product Standards**

Waste derived products include PHS and ash. None of these products are proposed to be used such that they will require the Applicant to meet the standards of 06 096 CMR Chapter 418: Beneficial Use of Solid Waste or 419: Agronomic Utilization of Residuals. PHS will be utilized on-site to fuel the biomass boilers and is exempt from the requirements of 06 096 CMR Chapter 418. Ash generated on-site will be disposed in a secure landfill licensed to accept it.

### **Technology Review Fiberight Process for MSW**

MRC contracted with the University of Maine's Forest Bioproducts Research Institute (FBRI) to conduct a peer review study of the Fiberight's technology to convert MSW to biofuels and other products. The results of the study concluded Fiberight's processing technology is sound and capable of converting the insoluble portion of MSW organics to a simple sugar solution. Presently at their pilot plant, Fiberight has successfully used sugar solutions from both the insoluble and soluble portion of MSW to produce biogas through anaerobic digestion (AD). FBRI prepared a report on January 30, 2015 titled *Technology Review Fiberight Process for MSW*. The report was subsequently provided to MRC. A copy of the report is provided in this Attachment. No substantial design changes to the Fiberight process for MSW provided in this Application have been made such that the outcome of the report's findings would be meaningfully altered.

**ATTACHMENT 23**

**REVISED OPERATIONS AND MAINTENANCE MANUAL**

# OPERATION AND MAINTENANCE MANUAL

FOR

**FIBERIGHT, LLC  
HAMPDEN, MAINE**

**DRAFT**

**Manual Prepared By:**  
CES, Inc.  
465 South Main Street  
P.O. Box 639  
Brewer, ME 04412  
207.989.4824

**MARCH 2016  
JN: 11293.001**

## TABLE OF CONTENTS

	Page
<b>FOREWORD</b>	
<b>GENERAL FACILITY OPERATIONS .....</b>	<b>1</b>
<b>A. OPERATIONS MANUAL.....</b>	<b>1</b>
<b>B. GENERAL OPERATIONS.....</b>	<b>1</b>
B.1 Operations .....	2
B.2 Personnel.....	3
B.3 Equipment.....	3
B.4 Environmental Monitoring.....	4
B.5 Fire Protection.....	4
B.6 Vector Control .....	4
B.7 Dust Control .....	5
B.8 Material Storage.....	5
B.9 Routine Maintenance and General Cleanliness.....	5
B.10 Erosion and Sedimentation Control.....	6
B.11 Tipping Floor Management Plan .....	6
B.12 Litter Control .....	6
<b>C. ACCESS TO FACILITIES .....</b>	<b>6</b>
<b>D. ACCEPTANCE AND DISTRIBUTION OF SOLID WASTE.....</b>	<b>7</b>
D.1 Acceptable Waste .....	7
D.2 Hazardous and Special Waste Handling and Exclusion Plan .....	7
D.3 Secondary Materials .....	7
D.4 Waste Disposal .....	7
D.5 Treated Wood .....	8
<b>E. WASTE CHARACTERIZATION .....</b>	<b>8</b>
E.1 Analytical Requirements.....	8
<b>F. ODOR CONTROL .....</b>	<b>9</b>
F.1 Introduction .....	9
F.2 Air Control and Odor Management System .....	10
F.3 Odor Inspections and Maintenance Procedures .....	11
F.4 Start-up, Shutdown, and Malfunction.....	11
F.5 Odor Complaint and Response Plan .....	12
<b>G. RECORD KEEPING .....</b>	<b>13</b>
<b>H. PERIODIC REPORTING .....</b>	<b>14</b>
<b>I. ANNUAL REPORT.....</b>	<b>14</b>
<b>J. FACILITY CLOSURE .....</b>	<b>15</b>
J.1 Closure Plan .....	15
J.2 Closure Performance Standard .....	15

## APPENDICES

- A. Location Map and Site Plan
- B. Solid Waste License
- C. Maine Solid Waste Management Regulations
- D. Hazardous and Special Waste Handling Exclusion Reports
- E. Hazardous and Special Waste Exclusion Reports
- F. Daily Inspection Reports
- G. Odor Complaint Response Form
- H. Operating Records
- I. Sources of Assistance

DRAFT



## FOREWORD

The purpose of this Operations and Maintenance (O&M) Manual, hereinafter referred to as “Manual” is to provide guidance to Fiberight, LLC (Fiberight) management and operating personnel for the operations and maintenance of the proposed processing facility (facility) located on a 95 +/- acre parcel in Hampden, Maine. This facility will be owned and operated by Fiberight. The Municipal Review Committee, Inc. (MRC) and Fiberight have an agreement as such that the MRC and its member communities will supply the Municipal Solid Waste (MSW) required to operate the facility. Fiberight submitted a Solid Waste Processing Facility License Application to the Maine Department of Environmental Protection (MDEP) in May 2015. This Manual is intended to ensure that Fiberight operates its facility in accordance with their Solid Waste License and the operational requirements specified in 06 096 CMR Chapter 409.4, last revised July 27, 2014. The facility is located off the Coldbrook Road approximately 0.6 miles to the south of Interstate 95. Refer to the Location Map in **Appendix A**.

This Manual has been prepared to conform with the Maine Solid Waste Management Regulations (MSWRs) effective November 2, 1998. Refer to a copy of the appropriate regulations in **Appendix C**.

Personnel involved in the daily operation of the facility consist of management and employees retained by Fiberight.

Fiberight is responsible for ensuring that operations are carried out in accordance with the current SWMRs, the facility’s Solid Waste License, and this Manual. This responsibility includes policy decisions, contractual arrangements, maintenance, accounting, fiscal, and other operations pertinent to the management and operation of the facility.

All on-site work will be performed by employees of Fiberight. Personnel operating the facility shall be familiar with, and follow, this Manual’s intent and general direction. No Manual can provide complete details or answers to all day-to-day problems and situations. Each operation is different. The Site Supervisor or Manager shall record any operational challenges that may arise and ensure corrective measures are taken as required. This information can be used to refine the Manual and provide guidance for facility operational changes if necessary. **Appendix I** contains a list of agencies, firms, and personnel that can provide assistance and answer any questions you may have regarding this Manual and basic operation of the facility.

## GENERAL FACILITY OPERATIONS

### A. OPERATIONS MANUAL

The Fiberight facility must be operated in accordance with this Manual which incorporates the operating requirements of its license and the Solid Waste Management Regulations (SWMRs). This Manual must be available for inspection by the Maine Department of Environmental Protection (MDEP) staff during normal business hours. This Manual must be updated to keep current with operational changes implemented at the processing facility.

This Manual includes the information that would enable supervisory and operating personnel, and persons evaluating the operation of the facility, to determine the manner in which policies, procedures, monitoring, maintenance, inspection, and legal requirements that are followed to ensure safe and environmentally sound operation on a daily and yearly basis.

A copy of the facility license, including amendments and revisions to that license, and a copy of the applicable sections of the most recent SWMRs can be found in **Appendices B** and **C**, respectively.

### B. GENERAL OPERATIONS

The Fiberight facility in Hampden is designed to process 650 tons per day of Municipal Solid Waste (MSW). The MSW generated within area communities, including 187 member communities of the Municipal Review Committee (MRC), will be delivered to the facility on a 5½ day basis in such volumes to support the daily processing rate. The facility has been designed to be able to accept a peak daily delivery of 950 tons per day of MSW. The as-delivered MSW is first pre-sorted to remove waste which cannot be processed (“Non-processible Waste”), such as inert materials, large bulky items, and waste which, in the reasonable judgment of the operator based upon visual inspection at the time of delivery could, if processed, result in damage to the facility, interruption of normal facility operations, or cause extraordinary processing or maintenance costs, solely by the virtue of the physical or chemical properties of such waste.

The pre-sorted material is then conveyed to a primary trommel where the processible waste over 20-inches is removed and routed to a shredder for size reduction<sup>1</sup>. The 1½-2-inch post shredder material is then sent to the fines processing system. The 20-inch minus material is routed to a screen where the 2-inch minus fines containing glass, grit, and small organic materials are removed and routed to the fines processing system. The over 2-inch material is sent to a continuous pulper undergoing a pulping process which produces a biomass pulp and a reject stream containing the majority of the recyclables. The pulper reject stream is then subjected to a second sort process in which the recyclables in the stream are segregated into their individual components for sale to the marketplace. The recyclables to be produced from the second sorting process and sold will be plastic films, rigid plastics, and ferrous and non-ferrous metals.

---

<sup>1</sup>The 20” screen size referred to above may be altered periodically depending on experienced waste composition and seasonal adjustments.

The remaining residue from the second sort process is deposited into staged roll-off containers or walking floor trailers for removal and eventual disposal.

The biomass pulp exiting the continuous pulper is routed to the wash system where any remaining soluble organic material, including solubilized food waste, as well as any remaining non-solubilized food waste, small inorganic materials, ash, sand, glass, small plastic particles, and/or grit (“wash system rejects”) are removed from the biomass pulp producing a clean cellulosic pulp. The solubilized organic material is pumped to the anaerobic digestion system where it is converted to biogas in a high rate Anaerobic Digester (AD) and the wash system rejects are conveyed to the fines processing system. The fines processing system is fed material from the post primary trommel overs shredder, the post trommel unders screen minus fraction, and the wash system rejects. In this system, the fines are separated into individual component streams of small plastics, metals, un-pulped material, wood and soluble organics, and residue. The metals are recovered and sold, the un-pulped material is sent back to the pulper, the PHS is conditioned as required for use as a boiler fuel, and the soluble organics are sent to the AD.

The clean cellulosic pulp from the wash system is then routed to be further processed in the pre-treatment system and finally the hydrolysis system. The pre-treatment system prepares the cellulosic pulp for hydrolysis by heat pasteurizing it and mechanically treating to facilitate the hydrolysis process. In the hydrolysis system, the pretreated pulp is exposed to enzymes thereby converting carbohydrates contained in the cellulose to sugars. The hydrolysate from the hydrolysis process is sent to a set of large filter presses where the unconverted cellulose or post hydrolysis solids (PHS) is removed from the stream with the purified industrial sugars being sent to either the AD or sold as industrial sugars dependent on market conditions. Sugars sent to the AD are converted to biogas, along with the soluble organics, purified, and injected in to the nearby natural gas pipeline. Residue materials from the secondary sort process and fines processing system are loaded into roll-off containers or transfer trailers and land filled.

## B.1 Operations

The facility must be operated and maintained in a manner that ensures it will meet the approved design requirements, will not contaminate ground or surface water, contaminate the ambient air, constitute a hazard to health or welfare, create a nuisance, and will meet the standards in Chapter 06 096 CMR Chapter 400, section 4.

Good housekeeping practices will be implemented as necessary to meet the standards described above. In addition, the following shall also be implemented or maintained:

1. All waste products received by the facility shall be handled inside the facility within the site confines, and stored and processed indoors within approved infrastructure. Waste handling, sorting activities, and storage will occur within the processing building. Refer to the Site Plan in **Appendix A** for the handling and processing areas. Material storage may be rotated between the different storage areas to allow for increases or decreases in demand of a particular product received by the facility.

2. A paved road provides access to the facility. If necessary during dry periods, the access ways may need to be wetted to control excessive dust generation resulting from facility activities. The access road will be kept free of excessive dirt and debris by sweeping or other methods, to ensure a clear travel way.
3. A Stormwater and Erosion and Sediment Control Plan has been prepared under separate cover.
4. Sequencing: All material received at the facility after weighing shall be delivered directly to the tipping area inside the facility (refer to Site Plan, **Appendix A**). Sequencing of material stored at the facility is not anticipated to occur.
5. Outgoing: Outgoing residue waste to be landfilled shall be loaded into roll-off containers or transfer trailers on an ongoing basis as for approximately 16 hours of each day of operations. On-site storage is not anticipated at the facility for durations requiring special licensing.
6. Parking and yard areas shall be maintained free of excessive dirt or debris.

## B.2 Personnel

The operation of the facility must be under the overall supervision and direction of a Site Supervisor or Manager qualified and experienced in the facility's operation, maintenance requirements, and safety procedures. The Site Supervisor or Manager must take whatever measures necessary to familiarize all personnel responsible for operation of the facility with relevant sections of this Manual.

## B.3 Equipment

Fiberight maintains equipment sufficient to meet the operational requirements of the facility. Routine maintenance of all equipment is provided as necessary. Below is a list of equipment maintained at the site.

1. \_\_\_\_\_
2. \_\_\_\_\_
3. \_\_\_\_\_
4. \_\_\_\_\_
5. \_\_\_\_\_
6. \_\_\_\_\_
7. \_\_\_\_\_
8. \_\_\_\_\_
9. \_\_\_\_\_

## B.4 Environmental Monitoring

The facility currently does not maintain a Storm Water Pollution Prevention Plan (SWPPP) because all processing activities will occur within a 144,000 square foot building. A facility qualifies for “no exposure” when all industrial activities and materials are protected by a storm resistant shelter designed to prevent exposure to stormwater, and the discharge satisfies the conditions at 40 CFR 122.26(g) and Appendix AE of the General Permit.

Fiberight will not be processing wastewater treatment sludge or septage; therefore, odor monitoring is not proposed at the facility. At a minimum, weekly odor inspections will be conducted at the facility during normal operations. Daily inspections will be conducted during initial operations. All processing at the facility will take place inside of a 144,000 square foot building and it is not expected that nuisance odors will materially exist outside of the facility.

No other environmental monitoring is proposed for this facility.

## B.5 Fire Protection

The Site Supervisor should make sure that the Town of Hampden Fire Department is familiar with the operations of the facility, and in conjunction with them, develop a Fire and Rescue Plan.

Fiberight shall prevent and control fires at the facility by complying with at least the following:

1. Arrangements shall be made with the Town of Hampden Fire Department to provide emergency service whenever needed in accordance with the Fire and Rescue Plan.
2. Both the Occupations Safety and Health Administration (OSHA – 29 CFR 1910.252(a) Fire Prevention and Protection Basic Precautions) and the National Fire Protection Association (NFPA - 51B Standard for Fire Prevention during Welding, Cutting, and Other Hot Work) have established specific requirements for conducting cutting operations (or other “hot” work). Both standards hold management and supervisors responsible for conducting overall safe cutting operations, providing fire protection equipment, and authorizing hot work. At a minimum, OSHA and NFPA fire prevention and protection standards should be utilized during “hot” work at the site.
3. Provide and maintain sufficient on-site fire equipment, such as detachable fire extinguishers for minor fires. Fire extinguishers shall be maintained in the facility at a number of locations, the office building, and on all mobile equipment.

## B.6 Vector Control

Vectors are considered to be any insect, bird, rodent, or other organisms capable of transmitting or carrying germs and disease. Vectors are usually only problematic at facility’s that store putrescible waste. Based on the nature of the materials processed at Fiberight, vectors will need to be controlled by means that eliminate the potential for transmitting germs and or disease. Therefore, Fiberight will contract with a licensed 3<sup>rd</sup> party contractor to create and operate a vector management plan designed to reasonably control vectors at the facility. Fiberight does not

anticipate storing putrescible waste for long periods of time because reserve waste supplies are not required for facility operations; therefore, nesting and reproduction opportunities for vectors may be managed.

## **B.7 Dust Control**

Section B.1 of this Manual provides dust control measures utilized at the facility.

## **B.8 Material Storage**

MSW Storage: The tipping floor in the facility is capable of storing MSW for up to two days prior to processing. MSW will be turned over every two days as it is received at the facility.

Residue Storage: Residues generated from sorting thru normal operations which results in material needing to be landfilled will not be stored on-site for any longer than 24 hours. Once a container or trailer is filled it will be transferred within 24 hours to a licensed solid waste facility for landfilling.

Recyclables Storage: Recyclables generated from sorting will only be stored on-site long enough to fill transport trailers and then sold as commodities on the open market.

## **B.9 Routine Maintenance and General Cleanliness**

Fiberight must provide for routine maintenance and general cleanliness of the entire facility site. This is accomplished through good housekeeping practices utilized at the site as described in Section B.1 of this Manual.

Weekly inspections of the facility will be performed. The inspections will include all processing equipment and infrastructure. A Facility Inspection Checklist is included in **Appendix F**. At a minimum, all equipment and infrastructure will be inspected for signs of corrosion, leaks, and waste build-up, as applicable. Infrastructure will also be inspected in accordance with manufacturers' recommendations. Additional inspections will be performed in accordance with the facility's Odor Management Plan, and Stormwater BMP Inspection Log. All infrastructure maintenance will be scheduled in accordance with manufacturers' recommendations unless otherwise indicated as necessary through routine inspection.

A copy of the Facility Inspection Checklist, as well as responses to any issues noted during the inspection, will be maintained at the facility and a summary of inspection results, including date of inspection and follow-up actions taken, will be included in the facility's annual report.

## **B.10 Erosion and Sedimentation Control**

The facility must control sedimentation and erosion during operation of the facility as required by the facility's Stormwater and Erosion and Sediment Control Plan.

## **B.11 Tipping Floor Management Plan**

During the MSW unloading process, a tip floor attendant will observe the waste and identify any material suspected of being unacceptable. Additionally, the loader operator will continuously look for material that may appear to be unacceptable waste as the incoming material is spread and stockpiled. To ensure that all MSW on the tipping floor can be accessed and inspected, and to ensure that no waste is allowed to stay on the floor for an extended period of time, waste will be placed in 3 numbered areas. The areas will be delineated through the use of painted stripes on the floor and up the back wall of the tipping floor. Each area number (1-3) will be painted on the wall. Each area will be filled and emptied progressively at a rate that is dependent on the waste acceptance rate for that day. For example, waste will be deposited in area 2 while it is being removed from area 1. As it is processed, waste will be removed to the bare floor prior to additional waste being placed in that location. Once the area has been emptied, a date stamped photograph will be taken, with the numbered wall clearly visible, as documentation and kept on file at the facility. This approach will allow for waste to be processed in the order that it enters the facility, first in/first out.

## **B.12 Litter Control**

Due to the fact that all waste handling activity is performed within the building, litter is not expected to become an issue at the facility. Regular inspections, daily and weekly, will be conducted around the facility and any litter will be noted and removed at that time. If it becomes evident that litter is becoming problematic, staff will review waste handling protocol to determine the likely cause and the appropriate change will be made, as practicable.

## **C. ACCESS TO FACILITIES**

Fiberight shall provide, and maintain in good repair, access roads at the facility site as well as maintain adequate space to allow the unobstructed movement of emergency personnel and equipment to operating areas of the facility. The access road will be gated and locked when the facility is not in operation. A sign will be posted outside if the facility displaying the hours of operation.

Fiberight's normal operational hours are:

Monday - Friday: 6:00 AM to 6:00 PM

Saturday: 6:00 AM to 2:00 PM



## **D. ACCEPTANCE AND DISTRIBUTION OF SOLID WASTE**

### **D.1 Acceptable Waste**

In general, MSW that is accepted at the facility includes solid waste originating from household and commercial sources. Fiberight may only accept wastes for which the facility has been specifically designed and permitted to accept by the MDEP. Incoming wastes must undergo a visual inspection and, if appropriate, analysis to ensure that only wastes allowed by the facility license are accepted at the facility. Screening for unacceptable waste will start at the scale house where the attendant will randomly interview drivers as to the contents of their loads. A list of common unacceptable items will be clearly posted at the scale house. During the unloading process on the tip floor, an attendant will observe the wastes as they are unloaded and examine any material suspected of being an unacceptable waste. Additionally, the loader operator will continuously look for material that may appear to be unacceptable as the incoming material is spread, stockpiled and eventually fed onto the conveyors feeding the Primary Sort Process. Although Universal and Household Hazardous Waste, such as Cathode Ray Tube Monitors, lamps, and solvents, will not be routinely accepted at the facility, Fiberight acknowledges that household waste may occasionally contain such an item. If such an item is discovered during waste handling, it will be removed from the process and stored in a designated area until it can be picked up for disposal at a facility licensed to handle the particular waste. The area will be 6ft X 6ft in size and enclosed. All wastes will be stored in appropriately labelled containers, for no more than 1 year. Fiberight will install a Closed Circuit Television (CCTV) system that will include cameras positioned to view the tip floor. To the extent practicable, Fiberight will use this system to augment visual inspections, and to track the source of any unacceptable waste.

### **D.2 Hazardous and Special Waste Handling and Exclusion Plan**

A Hazardous and Special Waste Handling and Exclusion Plan is included in **Appendix D** of this Plan.

### **D.3 Secondary Materials**

Secondary materials consist of post hydrolysis solids (PHS) resulting from the gasification of biomass residues. Solid residues from the hydrolysis process will be used in the facility's gasification boiler to serve the facility's electrical and heating needs. A Beneficial Use License (refer to 06 096 CMR Chapter 418.3.G) is not anticipated because the secondary materials are generated at the facility and will be combusted in the facility's boiler.

Secondary materials must be distributed in accordance with the provisions of this Manual (refer to Section D.4 below), or other applicable solid waste standards.

### **D.4 Waste Disposal**

The Operator must have procedures in place for disposal of residues and other solid waste generated by the processing facility, including contingency procedures for implementation during



emergencies and shutdown periods. The Operator must also maintain a valid contract with a solid waste facility that has MDEP approval to accept the waste.

Residue waste generated at the facility generally includes non-processibles, materials processing residue, and ash from the gasification of post hydrolysis solids/wood residues which will be used as boiler fuel at the facility, all of which will be landfilled at licensed solid waste facilities. Biofuel will be sold as Compressed Natural Gas (CNG). All residues separated from MSW will be transferred to a licensed disposal company in the State of Maine. Fiberight currently anticipates transporting all residues and bypass MSW to Crossroads Landfill in Norridgewock, and/or the Juniper Ridge Landfill in Old Town, and /or the Tri Community Landfill in Fort Fairfield; and/or the Hatch Hill Landfill in Augusta.

No liquid waste will be generated except for a process wastewater stream caused by periodically purging the plant water system. This process wastewater stream is collected in a tank, tested and discharged to the local wastewater treatment plant for processing.

Any other waste resulting from cleaning and maintenance of the facility will be processed or landfilled as described above.

#### **D.5 Treated Wood**

Wood accepted at the Fiberight facility will only be the small fraction that is expected to be included with incoming MSW. Fiberight will not accept separate supplies of woodwaste or process woodwaste such that it will be marketed and sold as biomass wood fuel, mulch or alternative daily landfill covers.

Fiberight does not accept construction and demolition debris wood or any source-separated treated wood for processing at their facility.

### **E WASTE CHARACTERIZATION**

#### **E.1 Analytical Requirements**

In accordance with 06 096 CMR Chapter 405.6.C. solid wastes proposed to be disposed at a solid waste disposal facility must be characterized in conformance with the requirements listed in 06 096 CMR Chapter 405.6.C. Fiberight will be producing non-organic residues and ash requiring disposal at a licensed solid waste facility. Non-organic residues which may be classified as “Miscellaneous Wastes” listed in 06 096 CMR Chapter 405.6.C.(2). The analytical requirements listed include the following:

- ◆ Complete Toxicity Characteristic Leaching Procedure (TCLP) (per US EPA Method 1311, Federal Register/Volume 55, No. 126, 1992);
- ◆ Totals for Aluminum, Arsenic, Barium, Boron, Cadmium, Chromium, Copper, Lead, Mercury, Molybdenum, Nickel, Selenium, Silver, and Zinc (per Methods in US EPA SW-846);

- ◆ Chloride, percent carbon, percent moisture, pH, phosphorus;
- ◆ Reactivity Characteristics;
- ◆ Ignitability Characteristics; and
- ◆ Additional parameters as identified by the applicant or the Department. These additional parameters must be based upon the raw material, the proposed activity, or the facility.

Fiberight anticipates generating between 3,000 and 4,000 tons of ash per year in the facility's biomass boiler. Ash will be disposed of in a landfill licensed to accept it and will be characterized in accordance with 06 096 CMR Chapter 405.6.C(4) and sampled for those parameters listed for biomass and fossil fuel boiler ash. Prior to initial acceptance at a solid waste facility, a sufficient number of samples to meet the requirements for statistical analysis as required by US EPA SW-846 must be analyzed as follows:

- ◆ TCLP Metals (Arsenic, Barium, Cadmium, Chromium, Lead, Mercury, Selenium, Silver) per US EPA Method 1311, Federal Register/Volume 55, No. 126, 1992;
- ◆ Chloride, percent carbon, percent moisture, pH, phosphorus.

After initial characterization is complete, ash must be analyzed for the parameters listed above at a frequency of one representative sample quarterly.

Additional analytical requirements may be required by the disposal facility receiving waste for disposal.

## **F. ODOR CONTROL**

### **F.1 Introduction**

Due to the nature of the wastes that are accepted at the Fiberight facility, the potential for occasional odors may exist. Multiple systems and procedures have been included in the design of the facility to minimize any off-site odor migration. An inspection and maintenance plan has also been developed to ensure that staff is able to quickly identify and mitigate any potential causes of nuisance odor. The Air Control and Odor Management Systems are outlined in Section F.2 below. Odor Inspection and Maintenance Procedures are outlined in Section F.3.

During normal operation of the facility, there may be times when the waste processing operation is suspended to perform maintenance on the equipment. To control odors that may occur during these outages a Start-Up, Shutdown, and Malfunction Plan for waste storage has been developed. This plan is outlined in Section F.4.

While systems have been designed to minimize any off-site odor, Fiberight has established an Odor Complaint Response Program to allow residents or businesses near the facility to report any potential issues, should they occur. This program also assists Fiberight with early identification and mitigation of any potential odor issues. The basic procedures for accepting and responding to an odor complaint are detailed in Section F.5. This section also provides the operator with a

list of additional controls that can be implemented to address any sources of odor that may be identified.

## **F.2 Air Control and Odor Management System**

The Fiberight facility has been designed to allow the operator to maintain negative pressure by the use of a multiple hood/intake register air removal system within the waste handling and processing areas of the building. In order to manage air-flow appropriately, two separate scrubber systems will be provided and sized to maintain a pressure of negative 0.1 inches of water column when the overhead doors are open. One of the odor scrubber trains will run continuously to maintain the design negative pressure, with the second system designed to supplement the primary odor scrubber system when the doors are open for waste delivery. To minimize the length of time the doors are open, to the greatest extent practicable, the door system design will incorporate high-speed fabric over-head doors to allow them to open and close at a faster speed than conventional over-head doors. As a precaution, an odor neutralizing spray system will be installed above the doors. Although this system will not be used during typical operations, it will serve as a back-up odor control measure should one of the scrubber systems require maintenance and a negative pressure cannot be maintained when the door is open. Air control hoods/registers have been strategically placed within the building to target areas where waste odors are more likely to be present. Each scrubber system has been designed with a cross-flow scrubber and a packed tower scrubber installed in series. The system is designed to remove odorants from the air prior to its discharge. The proposed odor control scrubbers will provide 95% control of ammonia, 99% control of hydrogen sulfide, and 99% of volatile organic compounds (VOCs). The filter media within the scrubbers is high efficiency polypropylene spherical packing through which the liquid scrubbing media flows to contact the gas stream. The media within the scrubber systems will be inspected and replaced in accordance to the manufacturer's recommendations.

Waste hauling vehicles are another potential source of odor at the facility. While Fiberight is not responsible for odors caused by these trucks while they are travelling to the facility, the operator has agreed to work with the haulers to minimize the risk of off-site odors caused at the facility due to idling vehicles. In the event that there is a waste truck that exhibits a higher degree of odor, the facility operator will prioritize that vehicle for entrance into the tip floor where odors can be controlled by the odor scrubber system operating in the tipping area. Fiberight will initiate communication with the hauler to identify the source of the waste and discuss potential ways to mitigate this situation in the future. Trucks from locations that typically have a higher degree of odor may be scheduled for receipt in order to minimize the time the truck is in queue.

The facility operator will maintain sufficient odor neutralizing agents on-site to respond to individual trucks or localized areas of the facility in a timely manner. Odor neutralizing agents will likely be in the form of powders and sprays that will allow for the appropriate application method based on the odor source.

### F.3 Odor Inspections and Maintenance Procedures

As part of operations of the facility, regular inspections will be performed. These inspections will include checks for existing odor as well as potential odor causing issues on the site. These inspections will include, at a minimum, daily visual observation of the operations for obvious signs of damage or abnormal conditions within the building that will affect collection efficiency of the odor control system. During the first month of, and for a total of 6 months during, the first year of operation a daily inspection and odor survey will be conducted around the facility. The daily inspection period must include the summer months when waste odors are expected to be strongest. If operations commence in the winter months and no odor issues are identified during the first month, inspections will be reduced to weekly until warmer weather. If after 6 months, including summer months, no odor issues are identified, inspections will be permanently reduced to weekly. Inspection results will be submitted to the MDEP weekly unless an odor incident is noted in which case the MDEP will be notified within the day. To assist the operator with continuous visual observations, visual indicators will be provided to ensure that air is being pulled into the building and from the hoods/registers.

The facility inspection should be conducted by a staff member that has not become desensitized to waste odors. During the inspection, the individual should walk around the facility and look for conditions that may cause odor and note any odor that was observed. Examples include: buildup of liquid on the access road that may have come from waste haul vehicles; odors observed around the stormwater ponds; and strong odors noted at any distance from the facility when the doors are opened. Any follow-up actions should be noted on the inspection form. This information will be used by the facility to schedule appropriate maintenance and further identify necessary odor control systems.

### F.4 Start-up, Shutdown, and Malfunction

There may be times during operations of the facility that systems will be offline for repairs due to scheduled maintenance or malfunction. Scheduled maintenance will be organized such that if possible, partial processing can still be carried out during these periods including the maintenance on the odor control systems. During these times, the operator will minimize the amount of waste material stored on-site and match the quantity stored with what is needed for continued processing at the then current capacity. It should also be noted that the odor control scrubbers will still be in operation during scheduled and unscheduled shutdowns of the balance of the facility.

If the scheduled maintenance or malfunction of the facility is of such a nature that the waste material stored on-site would not be able to be processed within seventy-two (72) hours, such as is the case for a long weekend, the operator has made arrangements with Waste Management's Crossroads Landfill in Norridgewock, Maine to accept bypass waste from the facility. In such circumstances, waste will be diverted at the earliest possible time to allow for minimal waste storage on the tipping floor during the shutdown. For extended shutdowns, the waste diversion procedures described above will be followed. Whenever possible, maintenance activities will be conducted during hours that the facility is not receiving waste. This will allow the operator to keep

the overhead doors in the closed position and to continuously operate at least one of the two odor scrubber trains. Unless there is an emergency condition, maintenance or repair activities that require both scrubber trains to be shutdown will be performed at scheduled times. The operator will reduce the quantity of waste to the maximum extent possible during these scheduled outages.

## F.5 Odor Complaint and Response Plan

Fiberight is aware that, as a solid waste facility, odors may be experienced on-site. Fiberight has taken numerous steps to minimize the migration of odors from the facility, and is committed to being a good neighbor and responding to any neighbor odor complaints that may be received. To better serve the surrounding community, the operator has established the following protocol for responding to odor complaints.

### F.5.1 Phone Number for Complaints

Since the facility will be continuously operated, trained staff will be available to receive odor complaints from the public 24 hours per day, 7 days per week. The operations manual will be amended to include a facility contact phone number once construction of the facility is completed.

### F.5.2 Basic Process for Odor Complaint Response

The basic steps to be followed when responding to an odor complaint is as outlined below:

1. When an odor complaint call is received, Fiberight staff shall obtain the necessary information from the caller to fill out an Odor Complaint Response Form (Form). This information includes: the caller's name and address; date and time of the complaint; and whether the caller would like someone to visit them at the location of the complaint to verify the odor. A copy of the Odor Complaint Response Form can be found in **Appendix G**.
2. The Form will be completed by the staff member answering the phone and the information relayed to the appropriately trained response staff for follow-up action.
3. If a visit is requested, the appropriate staff member should note the conditions observed during the visit. At a minimum, the following should be noted; wind direction, distance from the facility, and odor noted.
4. If a visit is not requested, or upon return from a visit, staff should perform an inspection of the facility to check for obvious sources of potential odor. Upon completion of the inspection the appropriate corrective measures should be taken.
5. The Fiberight staff member who is addressing the complaint shall notify Fiberight's Operations Manager within four hours of the complaint and notify MRC (as the landlord and owner of the property) and MDEP (as the regulatory agency) of the complaint immediately.
6. If MDEP determines that the facility created an off-site odor nuisance, Fiberight will submit a written report to the Department detailing the cause of the nuisance odor, follow-up actions taken, as well as plans for future treatment, minimization, and control of nuisance odors. This report will be submitted within 30 days.

### F.5.3 Future Odor Control Options

Should odors become an issue for the facility, and nuisance odors begin to migrate from the property to off-site occupied buildings, there are numerous options that can be employed at the facility.

1. Regular street sweeping/washing of the access road. During particularly dry periods of time, leakage from haul vehicles could accumulate on the access road and cause odors. An application of water for dust and odor control as well as sweeping could help to mitigate this issue. If regular washing, with water alone, is not sufficient, odor neutralizing agents can be added to the equipment to further reduce odors. As previously stated, odor neutralizing powders and spray will be stored on-site in order to minimize the time frame necessary to address odor issues.
2. Odor neutralizing spray within the building. Should the vacuum system within the building prove insufficient to control nuisance odors, or require short term maintenance, odor neutralizing spray could be applied to the waste on the tipping floor to reduce odors.
3. Odor neutralizing misting system. An odor neutralizing misting system could be installed along the boundary of the waste handling area, downwind of the operations, to assist in off-site odor control should odors begin to migrate off-site.
4. If the above measures are not sufficient to mitigate nuisance odors at off-site occupied buildings, the Operator will supplement the odor control systems to address the specific odor sources and issues causing nuisance odors.

### F.5.4 Documentation Retention and Reporting

All documentation required to be prepared by this plan (e.g., Odor Complaint Response Form, Inspection Report Form, Odor Inspection Form) shall be maintained on-site for five years and copies provided to MRC and MDEP upon request.

## G. RECORD KEEPING

Fiberight must make provisions to keep the following records and make them available for MDEP inspection and copying for the duration of the facility operation and a minimum of two years after facility closure:

1. When applicable, as-built engineering drawings of the facility, including a schematic showing the relationship of the various subsystems;
2. Analytical and characterization data results required by these rules or license conditions;
3. An Operation and Maintenance Manual meeting the requirements of this section 4.A; and
4. Copies of periodic and annual reports submitted to the MDEP.



Other records that should be kept so that easy preparation of the Annual Report required to be submitted to the MDEP are discussed in Section I below.

## H. PERIODIC REPORTING

Fiberight shall submit periodic reports to the MDEP containing the results of environmental monitoring, including waste characterization and any other information required in accordance with the facility license. During the initial year of operation, results of the odor inspections must be submitted to the MDEP on a weekly basis.

## I. ANNUAL REPORT

By February 28 of each year, the facility operator must pay an annual facility reporting fee to the State of Maine, as established by the Department, and submit an Annual Report to the MDEP for review and approval for the previous calendar year. The Annual Report must include a summary of activity at the facility during the past year, including a discussion of any odor problems, and a discussion of any factors, either at the facility or elsewhere, which affected the operation, design, or environmental monitoring program of the facility. The Annual Report must summarize the facility's activities, and at a minimum include the following:

1. Weight and type of wastes received by the facility and the data and results of the waste characterization;
2. Weight and type of product and secondary material produced;
3. Weight and type of secondary material used on-site and destination, and uses for material distributed off-site;
4. Weight and type of waste and secondary material stored on-site as of December 31;
5. Weight and description of residues leaving the facility for disposal, by destination, and the data and results of the waste characterization;
6. A demonstration that the facility meets the state's minimum recycling rate of 50%., through an analysis of the data provided in items 1-5 above, in accordance with *Processing Facilities, 06-096 CMR 409(4)(l)(d) and (e)*;
7. A general summary of the processing operation including problems encountered and follow-up actions, changes to the facility operation, and a summary of odor or other complaints received by the facility, as well as the responses to the complaints, during the previous year;
8. A summary of the results of the odor monitoring inspections, response actions and complaints, if any; and
8. Other alterations to the facility site, not requiring MDEP approval, that occurred during the reporting year. Minor aspects of the facility site proposed to be changed in the current year may be described in the Annual Report. Changes handled in this manner are those that do not require licensing under minor revision or amendment provisions of Chapter 400.

## **J. FACILITY CLOSURE**

### **J.1 Closure Plan**

Fiberight shall submit a Closure Plan to the MDEP a minimum of 90 days prior to the proposed date of the permanent closure of a solid waste processing facility. This must be submitted as a proposed minor revision to the existing facility license. The Plan must include:

- a. An outline of the proposed closing operation;
- b. A schedule for the removal of all stored wastes and secondary materials; and
- c. The intended destination of all stored wastes and secondary materials.

### **J.2 Closure Performance Standard**

The facility must be closed in a manner that minimizes the need for further maintenance; and so that the closed facility will not pollute any waters of the State, contaminate the ambient air, constitute a hazard to health or welfare, or create a nuisance. At a minimum, the Applicant must remove all wastes and secondary materials from the facility; and broom-clean the facility structures and equipment.

DRAFT



APPENDIX A  
LOCATION MAP AND SITE PLAN

DRAFT

**APPENDIX B**  
**SOLID WASTE LICENSE**

**DRAFT**

APPENDIX C

MAINE SOLID WASTE MANAGEMENT REGULATIONS

DRAFT

**APPENDIX D**

**HAZARDOUS AND SPECIAL WASTE HANDLING AND EXCLUSION PLAN**

**DRAFT**

## HAZARDOUS AND SPECIAL WASTE HANDLING AND EXCLUSION PLAN

### Facility Safety Officer

The facility Supervisor shall be designated as the “facility Safety Officer.” Annually, the facility Safety Officer shall work with the Hampden Fire Department to provide training to the operation staff on:

- ◆ Detection of hazardous and special waste;
- ◆ Appropriate notification procedures; and
- ◆ Appropriate handling procedures.

### Identification/Notification of Unpermitted Wastes

Unpermitted hazardous and special wastes shall not be accepted at the Fiberright facility. To ensure this, employees shall check all waste being deposited at the facility. The type of container and origin of the waste can help identify hazardous wastes and special wastes. Under no circumstances are people allowed to deposit any waste other than those listed in Section D.1 of this Manual.

If an unknown waste is observed by employees, the following list shall be used as guidance to help identify and handle materials of concern. Excluded items are not limited to those specifically listed below.

- ◆ Calcium Hypochlorite: Used for disinfecting pools but is reactive when wet. Can release chlorine gas and cause fire when wetted. Treat as hazardous; prevent wetting or contact with moisture; if wetted, evacuate area. Keep away from petroleum and other organic materials.
- ◆ Asbestos: Friable asbestos insulation which can easily become airborne is of the most concern. However, asbestos can take many forms and can be combined with other materials to sometimes make non-friable asbestos siding, flooring, or other products. If suspected to be or contain friable asbestos, contact the MDEP asbestos abatement program personnel at telephone number 207-287-2651. Avoid inhalation of particles.
- ◆ Bio-Medical Wastes: May be red bag waste from hospitals, laboratories, clinics, nursing homes, and occasionally doctors’ offices. These wastes include blood, body parts, disposable instruments, linens, and other soiled items. Keep people away, follow hazardous waste procedures, including notifying the appropriate responder either a qualified Fire Department or the MDEP. If accidentally contacted, disinfect contact area with 1:3 bleach to water solution.
- ◆ Industrial Chemicals: Generally, liquid in 5 gallon or larger pails or drums of either plastic or steel. Occasionally lined cardboard barrels are used. Also some solids, especially flakes or granular materials, can cause excessive corrosion or be reactive with liquids. Solids may be in any form of container including loose. Avoid skin contact and breathing exposure; treat as hazardous.

- ◆ Laboratory Chemicals: Usually in smaller containers of one pint to one gallon, glass or plastic bottles. Laboratory Chemicals can be severe irritants, highly toxic or explosive. Avoid skin contact and breathing exposure; do not open or jar containers. Treat as hazardous.
- ◆ Sandblast Grit: Generally fine sand or garnet mixed with paint, brick, and/or masonry chips. Avoid breathing; handle as special waste.
- ◆ Waste Oil: Includes used motor oils, hydraulic fluid, or other lubrication oils from individuals, farm operations, and vehicle and heavy equipment repair firms. Avoid skin contact; direct this material to the on-site used oil collection area.

### **Finding and Reacting to an Unknown Waste**

When unknown material is found at the facility, Fiberight shall identify the material to determine whether it is a licensed solid waste, special waste, universal, or hazardous waste. If the identified material is a hazardous waste, Fiberight shall attempt to identify the person who has left, delivered, or attempted to deliver the hazardous waste and notify the MDEP.

- ◆ While keeping a safe distance upwind from the material, the employees may attempt to determine the following, if safe to do so:
  - Look for container or waste labeling.
  - Determine the physical state of the material (solid, liquid, or gas).
  - Estimate container size or amount of waste.
  - Determine the type and condition of the container or packaging.
- ◆ If the material is determined to potentially be hazardous, the employees shall:
  - Evacuate and secure the area of the facility around the material.
  - If safely feasible, determine if there is any release of the material to the soil, water, or air.
  - If safely feasible, determine if any release found has been confined or is ongoing.
  - Undertake the appropriate notification procedure below.

### **Notification**

When hazardous waste or suspected hazardous waste is found left at the facility, employees shall:

- ◆ Notify the Hampden Fire Department at 862-4586
- ◆ Notify the MDEP anytime at 1-800-482-0777 or the Maine State Police at 1-800-452-4664.

When unpermitted special waste is found left at the facility, Fiberight shall notify a Solid Waste Staff person at the MDEP regional office between 8:00 a.m. to 5:00 p.m., Monday through Friday. Once approved by MDEP, Fiberight shall authorize removal of any unpermitted waste.

If Fiberight cannot identify the material; notify the Hampden Fire Chief and the MDEP at the number listed above for assistance in identification. If sampling and further detection of hazardous or special waste is required, a qualified hazardous waste handling firm or solid waste contractor must be used, as appropriate.

### Clean-up/Decontamination

Only trained personnel shall handle hazardous wastes. Such training shall follow the guidelines of 29 CFR Part 1910.120. Unpermitted special wastes shall be removed from the area where found and transported to a special waste disposal facility licensed to accept that special waste within 60 days. Because hazardous wastes require special training to handle, and to minimize the area of potential, it is recommended that any hazardous waste found at the solid waste facility be removed by qualified personnel from the site directly.

### Emergency Information

Fiberight shall have the following telephone numbers available at the facility for telephone notifications:

MDEP-Bureau of Remediation & Waste Management, Bangor Office	941-4570	Normal business hours
MDEP-Emergency Spill Hot Line	1-800-482-0777	After hours or weekends
Hampden Fire Department	862-4586	
Hampden Police Department	862-4000	
Ambulance	911	
Maine State Police	1-800-452-4664	For reporting hazardous waste
Maine Poison Center	1-800-442-6305	

The closest location for emergency medical care is Eastern Maine Medical Center (EMMC) in Bangor.

#### Directions to EMMC

1. North on Interstate 95.
2. Take Hogan Road exit in Bangor and turn right onto Hogan Road.
3. Follow Hogan Road approximately 1 mile and merge onto State Street.
4. Continue following State Street for approximately 8/10 mile.
5. Turn Left into EMMC Emergency Room.

### Written Reports

A written report shall be filed with the MDEP-Bureau of Remediation & Waste Management within 15 days of any incident involving hazardous waste or material.

The report must indicate:

- ◆ Date and time of incident;
- ◆ Location;
- ◆ Material lost or spilled;
- ◆ Amount lost or spilled;

- ◆ Amount recovered;
- ◆ Cause of the incident;
- ◆ Corrective action taken;
- ◆ Clean-up method used;
- ◆ Disposition of recovered materials;
- ◆ List of agencies notified; and
- ◆ Time agency responded on-site.

DRAFT



APPENDIX E

HAZARDOUS AND SPECIAL WASTE EXCLUSION REPORTS

DRAFT

APPENDIX F  
DAILY INSPECTION FORM

DRAFT

**ODOR INSPECTION REPORT FORM**

Date: \_\_\_\_\_  
Inspector Name: \_\_\_\_\_  
Weather Conditions: \_\_\_\_\_

**Building Condition**

- Obvious damage to overhead doors? (y/n)
- Odors noted when door is closed? (y/n)
- Odors noted when door is open? (y/n)
- Visual evidence of negative air at the door? (y/n)
- Obvious damage to building walls? (y/n)

**Yard and Access Road Condition**

- Any waste present around the facility? (y/n)
- Any waste or liquid spillage on the access road? (y/n)
- Any odor noted away from the building? (y/n)
- Any odor noted around the stormwater management structures? (y/n)

**Follow-up Notes**

Please list any other conditions noted during the inspection and the steps taken to correct the issue:

---

---

---

---

---

---

---

---

DRAFT

APPENDIX G

ODOR COMPLAINT RESPONSE FORM

DRAFT

### ODOR COMPLAINT REPORT

*Top portion of this form is to be filled out at the time of the complaint.*

Date: \_\_\_\_\_

Time: \_\_\_\_\_

Name of caller: \_\_\_\_\_

Contact information for the caller:

\_\_\_\_\_  
Location of complaint:

Does the caller wish to have the odor verified? (y/n)

\*\*\*\*\*  
\*\*\*\*\*

*Bottom portion of this form is to be filled out by the responder.*

Was a visit to the caller conducted? (y/n)

Distance of the complaint from the facility: \_\_\_\_\_

Was an odor noted? (y/n)

Was the caller's location downwind of the facility? (y/n)

Is there anything unusual happening at the facility? (Shutdown, maintenance, etc.?) (y/n)

Any unusually odorous waste loads delivered? (y/n)

Was a follow-up inspection conducted at the facility? (y/n)

List any items identified during the inspection that require attention.

\_\_\_\_\_

What steps were taken to correct any issues identified?

\_\_\_\_\_

\_\_\_\_\_

**APPENDIX H**  
**OPERATING RECORDS**

**DRAFT**

**APPENDIX I**  
**SOURCES OR ASSISTANCE**

**DRAFT**

## SOURCES OR ASSISTANCE

### **Consultant:**

CES, Inc.  
Denis St. Peter, P.E.  
465 South Main Street  
Brewer, Maine 04412  
Office: 989-4824

### **Owners:**

Fiberight, LLC  
853 Industrial Park Drive  
Lawrence, VA 23868  
Office: 410-340-9387

Municipal Review Committee, Inc.  
395 State Street  
Ellsworth, ME 04605  
Office: 207-664-1700

### **Police:**

Hampden Police Department  
106 Western Avenue  
Emergency Tel: 911  
Non-Emergency Tel: 862-4000

### **Fire:**

Hampden Fire Department  
106 Western Avenue  
Tel: 862-4586

### **Asbestos Handling & Disposal:**

Asbestos Removal, Inc.  
739 Odlin Road  
Bangor, ME 04401  
Tel: 947-4035

### **Hazardous Waste:**

Bureau of Remediation and Waste Management  
Maine Department of Environmental Protection  
17 State House Station  
Augusta, ME 04333-0017  
Office: 287-7800

### **Solid Waste Facilities Regulation:**

Bureau of Remediation and Waste Management  
Maine Department of Environmental Protection  
106 Hogan Road  
Bangor, ME 04401  
Attn: Karen Knuuti  
Office: 941-4570



**UPDATE SITE PLAN  
SHEET C101**



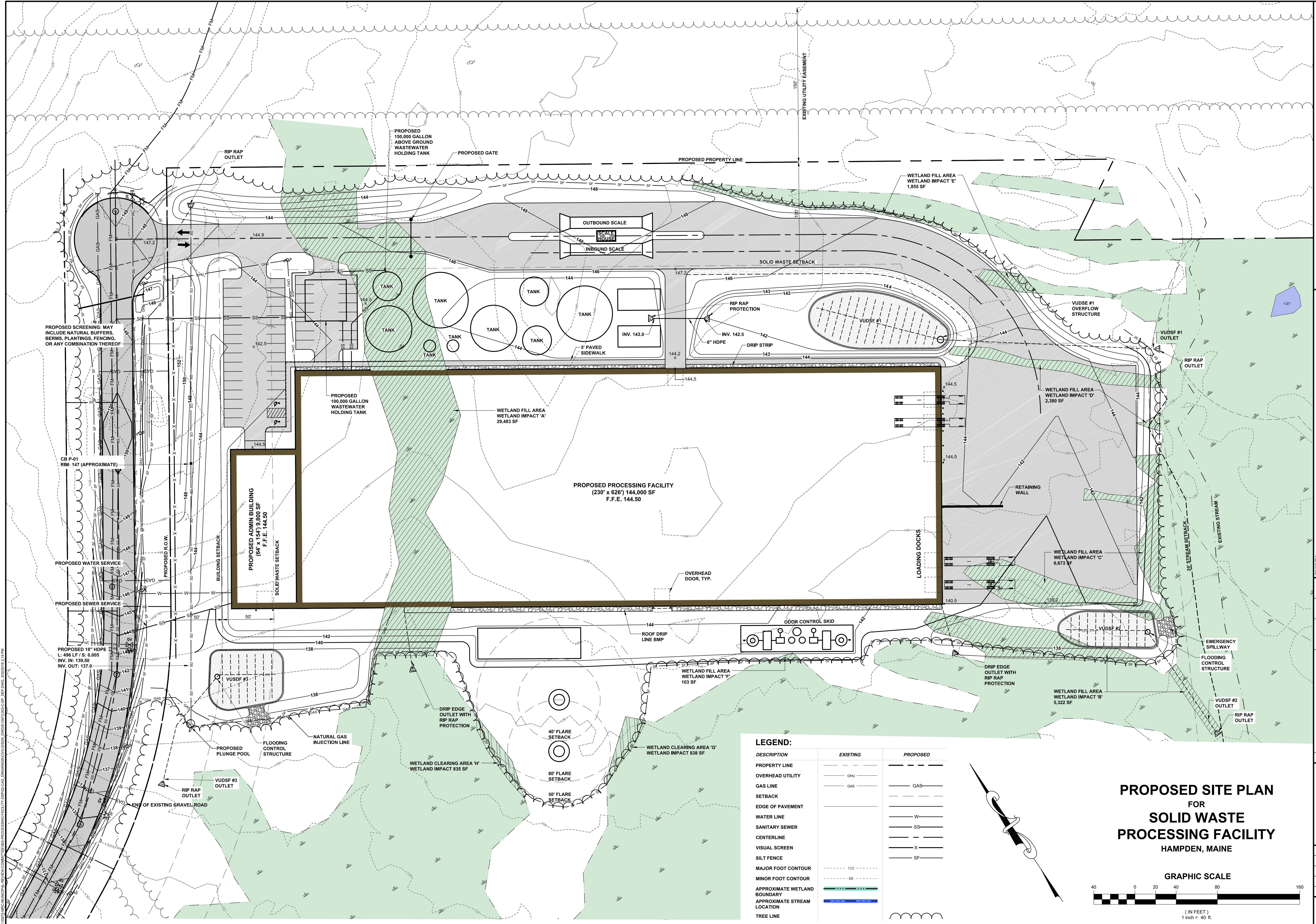

PROPOSED SCREENING: MAY INCLUDE NATURAL BUFFERS, BERMS, PLANTINGS, FENCING, OR ANY COMBINATION THEREOF

CB P-01  
RIM: 147 (APPROXIMATE)

PROPOSED WATER SERVICE

PROPOSED SEWER SERVICE

PROPOSED 18" HDPE  
L: 496 LF / S: 0.005  
INV. IN: 139.50  
INV. OUT: 137.0

**LEGEND:**

DESCRIPTION	EXISTING	PROPOSED
PROPERTY LINE		---
OVERHEAD UTILITY	OHU	
GAS LINE	GAS	
SETBACK		---
EDGE OF PAVEMENT		---
WATER LINE	W	
SANITARY SEWER	SS	
CENTERLINE		X
VISUAL SCREEN		SF
SILT FENCE		SF
MAJOR FOOT CONTOUR	100	
MINOR FOOT CONTOUR	98	
APPROXIMATE WETLAND BOUNDARY		---
APPROXIMATE STREAM LOCATION		---
TREE LINE		---

**PROPOSED SITE PLAN**  
FOR  
**SOLID WASTE PROCESSING FACILITY**  
HAMPDEN, MAINE

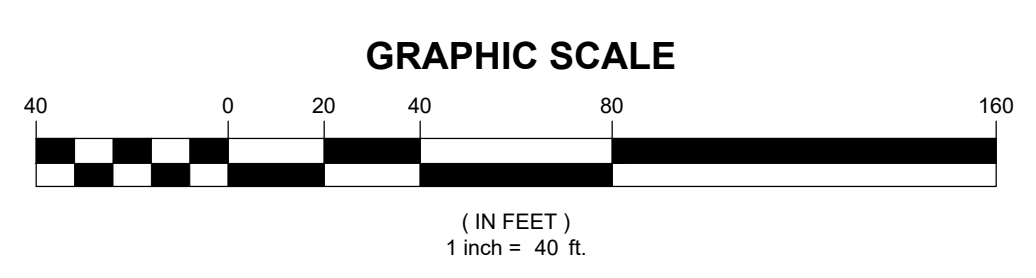

Waldville  
44 Main Street  
Waldville, ME  
F. 207-798-2302  
F. 207-798-8412  
F. 207-798-8414  
F. 207-798-8414  
F. 207-798-8414  
F. 207-798-8414  
F. 207-295-5887

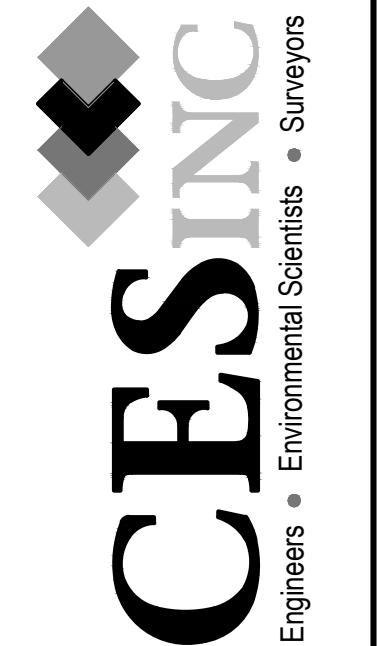

MRC / FIBERIGHT SOLID WASTE PROCESSING FACILITY  
HAMPDEN, MAINE

**PROPOSED SITE PLAN**

NO.	DATE	BY	DESCRIPTION
1	2016-03-25	WAB	SMT
2			
3			
4			
5			
6			
7			
8			
9			
10			



SCALE: 1"=40'  
DATE: 2015-12-10  
DRAWN BY: BQ/WAB CHECKED BY: SMT  
DESIGNED BY: BQ/SMT APPROVED BY: SMT  
JOB NUMBER: 10673.003  
DRAWING NUMBER: C101



**AMENDED GEOTECHNICAL REPORT SIGNATURE PAGE**

## 5.0 CLOSURE

It has been a pleasure to be of assistance to you with this phase of your project. If you have any questions, or if we may be of further assistance, please do not hesitate to contact us.

Sincerely,

**S. W. Cole Engineering, Inc.**

Nathan D. Strout, P.E.  
Geotechnical Engineer



Robert E. Chaput, Jr., P.E.  
Senior Geotechnical Engineer

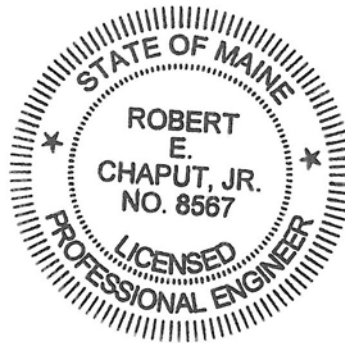

NDS:rec

**GENERAL ARRANGEMENT PROCESS DIAGRAM**

# General Arrangement Process Diagram

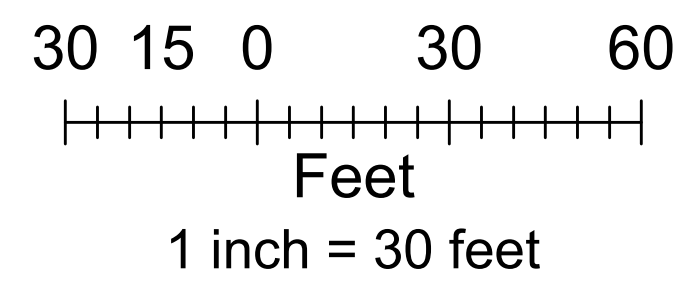
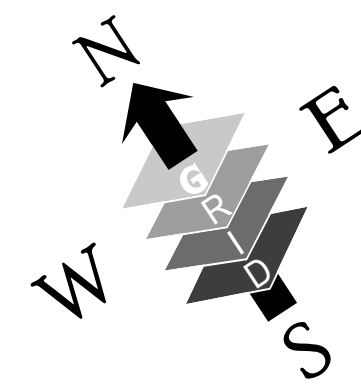

## Legend

- Pit
- ▲ Scrubber Intake
- MSW Processing Flow
- ▶ Drain
- Duct
- Wall (MSW/Processing Area)
- Stormwater Line
- Sewer Line
- Gas Line
- Water Line
- Drip Edge Outlet
- Drip Strip
- Operational Features
- Building
- Pond
- Scales
- Tank
- Road
- Anaerobic Digestion Area
- Hydrolysis Area
- Materials Recovery Facility Area
- Pulp Area
- Wash Area
- Waste Water Treatment Area



### MAP NOTES:

- 1: SITE DATA DEVELOPED BY CES, INC., DECEMBER, 2015.
- 2: OPERATIONAL FEATURES AND INFRASTRUCTURE PROVIDED BY FIBERIGHT, 2015. LOCATIONS ARE APPROXIMATE AND ARE SUBJECT TO CHANGES.
- 3: MAP IS PROJECTED USING STATE PLANE COORDINATES, US SURVEY FEET, EAST ZONE AND REFERENCES THE NORTH AMERICAN DATUM OF 1983 (NAD83).
- 4: NORTH ARROW IS REFERENCED TO GRID NORTH.
- 5: INTENDED FOR REFERENCE PURPOSES ONLY. THE MRC & CES, INC. AND THEIR AFFILIATES ARE NOT RESPONSIBLE FOR THE MISUSE OF THIS MAP OR DATA DEPICTED HEREIN.

Fiberight, LLC. & Municipal Review Committee  
 Project No.: 11293.001  
 Updated: 3/30/2016 [lladd]

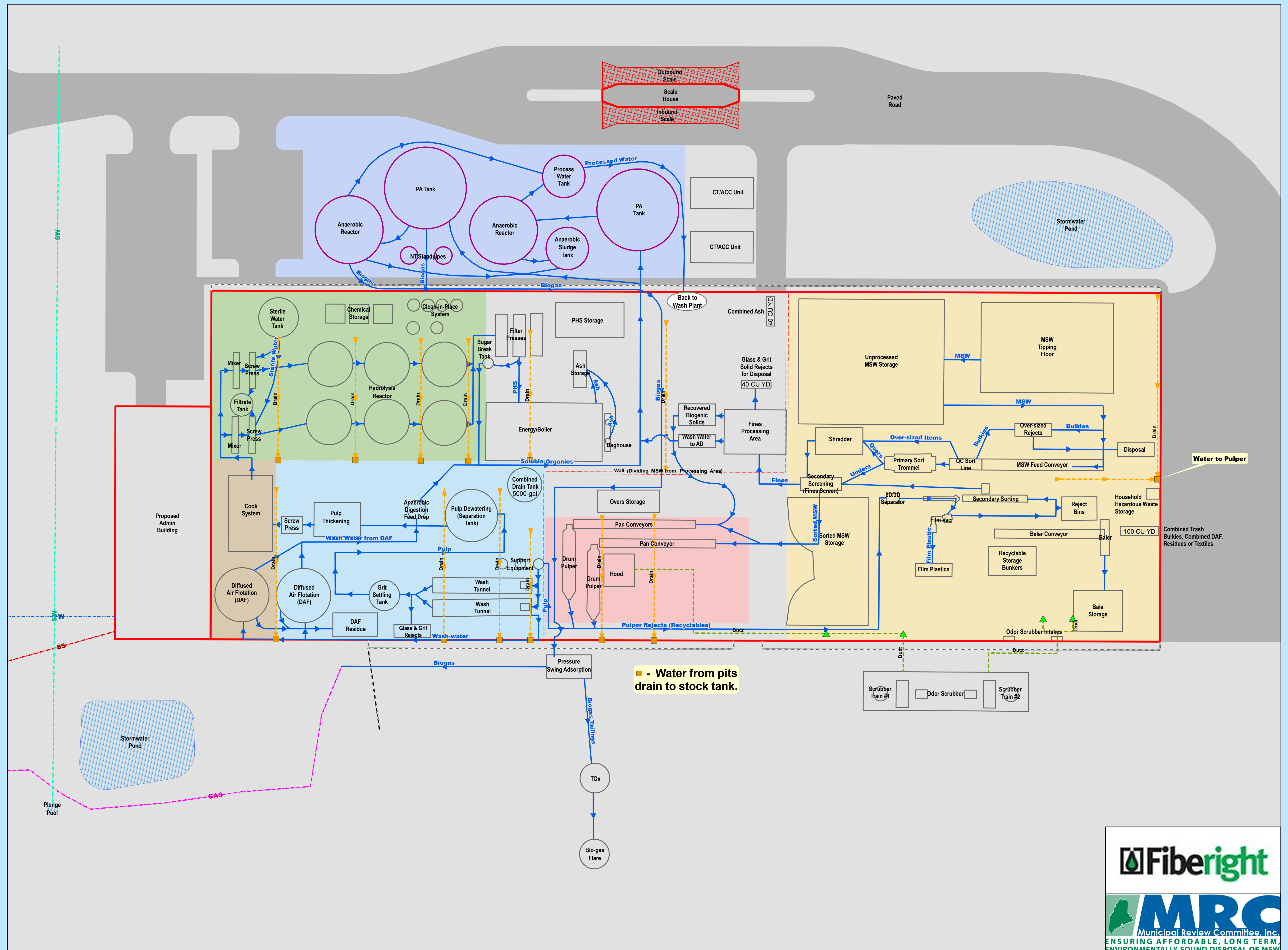

■ - Water from pits drain to stock tank.



MXD: P:\11293-Fiberight\001-Solid Waste Facility\GIS Data\MXD\General Arrangement Process Diagram 2016.mxd